

(19)



(11)

**EP 3 010 402 B1**

(12)

**EUROPEAN PATENT SPECIFICATION**

(45) Date of publication and mention of the grant of the patent:  
**10.10.2018 Bulletin 2018/41**

(51) Int Cl.:  
**A61N 5/10 (2006.01) G06F 19/00 (2018.01)**  
**G16H 10/60 (2018.01) G16H 50/70 (2018.01)**

(21) Application number: **14813453.9**

(86) International application number:  
**PCT/US2014/043474**

(22) Date of filing: **20.06.2014**

(87) International publication number:  
**WO 2014/205386 (24.12.2014 Gazette 2014/52)**

**(54) MULTI-OBJECTIVE RADIATION THERAPY SELECTION SYSTEM AND METHOD**

SYSTEM UND VERFAHREN ZUR MEHRZIELAUSWAHL EINER STRAHLENTHERAPIE

SYSTÈME ET MÉTHODE DE SÉLECTION D'UNE OU DE PLUSIEURS RADIOTHÉRAPIES À OBJECTIFS MULTIPLES

(84) Designated Contracting States:  
**AL AT BE BG CH CY CZ DE DK EE ES FI FR GB GR HR HU IE IS IT LI LT LU LV MC MK MT NL NO PL PT RO RS SE SI SK SM TR**

- **DAVIDI, Ran**  
Sunnyvale, CA 94087 (US)
- **MOURLAS, Nicholas**  
Mountain View, CA 94043 (US)
- **ATWOOD, Todd**  
Menlo Park, CA 94025 (US)

(30) Priority: **21.06.2013 US 201361837754 P**  
**13.09.2013 US 201361877291 P**

(43) Date of publication of application:  
**27.04.2016 Bulletin 2016/17**

(74) Representative: **Williams, Michael Ian**  
**Cleveland**  
**10 Fetter Lane**  
**London EC4A 1BR (GB)**

(60) Divisional application:  
**18191965.5**

(73) Proprietor: **Siris Medical, Inc.**  
**Redwood City, CA 94063 (US)**

- (56) References cited:
- |                            |                            |
|----------------------------|----------------------------|
| <b>WO-A1-2008/016795</b>   | <b>WO-A1-2012/080906</b>   |
| <b>US-A1- 2002 080 915</b> | <b>US-A1- 2004 071 261</b> |
| <b>US-A1- 2006 173 663</b> | <b>US-A1- 2010 054 411</b> |
| <b>US-A1- 2011 106 749</b> | <b>US-A1- 2011 124 976</b> |
| <b>US-A1- 2011 153 547</b> | <b>US-A1- 2011 301 977</b> |
| <b>US-A1- 2012 136 194</b> | <b>US-B2- 7 835 500</b>    |
| <b>US-B2- 8 346 354</b>    |                            |

(72) Inventors:  
• **CARPENTER, Colin**  
**San Carlos, CA 94070 (US)**

**EP 3 010 402 B1**

Note: Within nine months of the publication of the mention of the grant of the European patent in the European Patent Bulletin, any person may give notice to the European Patent Office of opposition to that patent, in accordance with the Implementing Regulations. Notice of opposition shall not be deemed to have been filed until the opposition fee has been paid. (Art. 99(1) European Patent Convention).

**Description**

## TECHNICAL FIELD

**[0001]** This application is generally related to facilitating creation of radiation treatment plans.

## BACKGROUND

**[0002]** Providing radiation therapy to patients diagnosed with cancer includes creating a radiation treatment plan. Often, where the cancer is localized in the patient's anatomy, such as in a tumor, the creation of the radiation treatment plan involves participation by medical personnel for solving a difficult geometric problem and/or making judgment calls related to the total radiation dose or total dose received by the tumor and nearby healthy tissue, including organs at risk (OARs). Creating the radiation treatment plan can be a time consuming process that involves multiple medical personnel providing multiple iterations of the treatment plan over many days, which may increase the time from diagnosis of the cancer to treatment of the cancer.

**[0003]** In an example of a conventional process for the diagnosis and treatment of tumors, a diagnostic scan, such as a computed tomography (CT) scan, is taken of the patient to localize a tumor and a biopsy of the tumor is taken to histologically verify that the tumor is malignant. Next, treatment contours of the three dimensional envelope defined by the tumor's shape and the shape of the OARs are drawn up and a treatment prescription is developed by a clinician or an oncologist. The treatment prescription prescribes a total radiation dose to be delivered to the tumor over the course of treatment and a maximum level of radiation to be absorbed by the OARs. Next, the treatment prescription is provided to medical personnel, such as a dosimetrist, and a radiation delivery plan is developed by the medical personnel. The radiation delivery plan includes radiation beam orientations, shapes, and fluences using a given radiation type and delivery method to achieve the radiation levels, including the total dose levels, defined by the treatment prescription. Treatment constraints, including at least the treatment prescription and the radiation delivery plan, are iteratively changed by the medical personnel to meet minimum standards and to satisfy the oncologist. The final iteration of the radiation delivery plan is used to treat the patient.

**[0004]** This process for developing a radiation treatment plan can take many days, especially in cases in which the medical personnel, including the dosimetrist and/or the oncologist, change the treatment constraints over a number of iterative cycles.

WO 2012/080906 discloses a system for clinical decision support in which current patient information is provided to a treatment planning workstation. The treatment planning workstation transmits current patient information to a similarity search engine. The similarity search engine

retrieves data on previous patients from a previous patient database, which is then compared to the information about the current patient. Previous patients having a high degree of similarity to the current patient are provided to the doctor via the treatment planning workstation. The treatment planning workstation is used by the doctor or other medical professional to plan treatment for the current patient.

US 2011/0153547 discloses a method of determining a new treatment plan for a new patient, comprising: providing a representation of the new patient's organ at risk relative to a target; searching for a prior treatment plan for a prior patient with a similar representation; and reviewing the prior treatment plan for the prior patient in order to determine whether the new treatment plan can be improved based on information in the prior treatment plan.

## SUMMARY

**[0005]** According to one aspect of the present invention there is provided a system for facilitating a radiation treatment plan as defined in claim 1.

**[0006]** According to another aspect of the present invention there is provided a computer-implemented method for facilitating creation of a radiation treatment plan as defined in claim 14.

**[0007]** Preferred features of the invention are recited in the dependent claims.

**[0008]** The invention is defined in the claims, other embodiments being merely exemplary.

**[0009]** Embodiments of the invention include systems and methods for facilitating creation of patient treatment plans based on parameters from previously planned patient treatments. Embodiments of the invention may facilitate providing medical personnel with treatment information for creating achievable radiation treatment plans, saving hours and days of labor, and reducing the time from diagnosis of the cancer to treatment of the cancer.

**[0010]** According to Example 1, a system for facilitating creation of a patient treatment plan comprises memory that stores computer-executable instructions and at least one processor configured to execute the computer-executable instructions, which, when executed, cause the at least one processor to provide a number of components. In embodiments, the components include a search component configured to identify, based on one or more features associated with patient data, at least one matching plan from a database of previously planned radiation treatments; and a user interface configured to present, to a user, one or more parameters associated with the at least one matching plan.

**[0011]** In Example 2, the system of Example 1, wherein the one or more features associated with patient data include at least one of a physics parameter, a treatment type parameter, a patient image parameter, and a disease parameter.

**[0012]** In Example 3, the system of any of Examples 1

and 2, wherein the one or more features associated with patient data include a patient image parameter and the computer-executable instructions, when executed, cause the at least one processor to further provide a feature extractor configured to extract from a patient image the patient image parameter.

**[0013]** In Example 4, the system of any of Examples 1 - 3, wherein the one or more features associated with patient data include a patient image parameter extracted from a patient image that comprises an imaging scan of the patient produced by one or more of ionizing energy, acoustic energy, computed tomography, magnetic resonance imaging, positron emission tomography, an x-ray, and fluoroscopy.

**[0014]** In Example 5, the system of any of Examples 1 - 4, wherein the one or more parameters associated with the at least one matching plan include at least one of a physics parameter, a treatment type parameter, an image parameter, and a disease parameter.

**[0015]** In Example 6, the system of any of Examples 1 - 5, wherein the computer-executable instructions, when executed, cause the at least one processor to further provide a prediction component configured to determine at least one metric that includes a predictor of a treatment outcome.

**[0016]** In Example 7, the system of any of Examples 1 - 6, wherein the computer-executable instructions, when executed, cause the at least one processor to further provide a prediction component configured to determine at least one metric that includes a combination of two or more of the parameters associated with the at least one matching plan.

**[0017]** In Example 8, the system of any of Examples 1 - 7, wherein the computer-executable instructions, when executed, cause the at least one processor to further provide a prediction component configured to determine at least one metric using at least one of a machine learning technique, a pattern matching technique, and a data mining technique.

**[0018]** In Example 9, the system of any of Examples 1 - 8, wherein the computer-executable instructions, when executed, cause the at least one processor to further provide a plan recommendation component configured to recommend at least one of the previously planned radiation treatments.

**[0019]** In Example 10, the system of Example 9, wherein the plan recommendation component is configured to cause at least one parameter from the at least one matching plan to be inserted automatically into the patient treatment plan.

**[0020]** In Example 11, the system of any of Examples 1 - 10, wherein the computer-executable instructions, when executed, cause the at least one processor to further provide a prediction component configured to determine at least one metric that is correlated to a treatment dose.

**[0021]** In Example 12, the system of Example 11, wherein the search component is configured to identify

a plurality of matching plans from the database of previously planned radiation treatments, and the prediction component is configured to use the at least one metric to facilitate selection of one of the plurality of matching plans.

**[0022]** In Example 13, the system of any of Examples 1-9, 11, and 12, wherein the computer-executable instructions, when executed, cause the at least one processor to further cause at least one parameter from the at least one matching plan to be inserted automatically into the patient treatment plan.

**[0023]** In Example 14, the system of any of Examples 1 - 13, wherein the memory and the at least one processor are located remotely with respect to a point of care that uses the system.

**[0024]** In an Example 15, a method for facilitating creation of a patient treatment plan comprises receiving, by a processor, at least one feature associated with patient data; searching, by the processor, a database of previously planned radiation treatments; identifying, by the processor, a plurality of matching plans from the database based on the at least one feature; and determining, by the processor, at least one metric that is correlated to a treatment dose.

**[0025]** In Example 16, the method of Example 15, further comprising presenting, by a user interface, at least one parameter corresponding to the plurality of matching treatment plans.

**[0026]** In Example 17, the method of any of Examples 15 and 16, further comprising inserting, by the processor, into the patient treatment plan at least one parameter corresponding to the plurality of matching treatment plans.

**[0027]** In Example 18, the method of any of Examples 15 - 17, further comprising extracting the at least one feature from an imaging scan of the patient.

**[0028]** In Example 19, the method of any of Examples 15 - 18, wherein determining, by the processor, the at least one metric that is correlated to a treatment dose comprises determining the at least one metric using at least one of a machine learning technique, a pattern matching technique, a data mining technique.

**[0029]** In Example 20, the method of any of Examples 15 - 19, further comprising selecting, by the processor and based on the at least one metric, one of the plurality of matching treatment plans.

**[0030]** In Example 21, the method of Example 20, further comprising presenting, by a display device, at least one parameter corresponding to the selected one of the plurality of matching treatment plans.

**[0031]** In Example 22, the method of any of Examples 20 and 21, further comprising inserting, by the processor, into the patient treatment plan at least one parameter corresponding to the selected one of the plurality of matching treatment plans.

**[0032]** In an Example 23, one or more non-transitory computer-readable storage media have computer-executable instructions embodied thereon that, when exe-

cuted by a processor, cause the processor to instantiate a plurality of computer program components. In embodiments, the plurality of computer program components comprise a search component configured to identify, based on one or more features associated with patient data, a plurality of matching plans from a database of previously planned radiation treatments; a prediction component configured to determine at least one metric that is correlated to a treatment dose and to facilitate selection of one of the plurality of matching plans using the at least one metric; and a user interface configured to present, to a user, one or more parameters associated with the one of the plurality of matching plans.

**[0033]** In Example 24, the media of Example 23, wherein the at least one metric includes at least one of a predictor of a treatment outcome and a combination of two or more of the parameters associated with the one of the plurality of matching plans.

**[0034]** In Example 25, the media of any of Examples 23 and 24, wherein the plurality of computer program components comprises a plan recommendation component configured to cause at least one parameter from the one of the plurality of matching plans to be inserted automatically into a patient treatment plan.

#### BRIEF DESCRIPTION OF THE DRAWINGS

##### **[0035]**

FIG. 1 is a block diagram illustrating a system for facilitating creation of a patient treatment plan in accordance with embodiments of the present invention;

FIG. 2 is a block diagram illustrating an extraction system for creating a processed database from a medical data database in accordance with embodiments of the present invention;

FIG. 3 is a block diagram illustrating another system for facilitating creation of a patient treatment plan in accordance with embodiments of the present invention;

FIG. 4 is a block diagram illustrating a computing device for implementing aspects of a system for facilitating creation of a treatment plan in accordance with embodiments of the present invention; and

FIG. 5 is a flow diagram depicting an illustrative method for facilitating creation of a patient treatment plan in accordance with embodiments of the present invention.

**[0036]** Although the term "block" may be used herein to connote different elements illustratively employed, the term should not be interpreted as implying any requirement of, or particular order among or between, various steps disclosed herein unless and except when explicitly referring to the order of individual steps.

#### DETAILED DESCRIPTION

**[0037]** FIG. 1 is a block diagram illustrating a system 100 for facilitating creation of a patient treatment plan in accordance with embodiments of the invention. The system 100 may be used, for example, to facilitate creation of a radiation treatment plan for a cancer patient. In embodiments, non-transitory computer-readable storage media or memory that stores computer-executable instructions, and at least one processor configured to execute the computer-executable instructions may provide one or more components of the system 100. As shown in FIG. 1, the system 100 includes a search component 102, a user interface 104, and a database 106. The search component 102 is communicatively coupled to the database 106 by communications path 108 and to the user interface 104 by communications path 110. Additionally, in embodiments, the user interface 104 may be communicatively coupled to the database 106.

**[0038]** The communications paths 108 and 110 may include any type of communication path suitable for facilitating unidirectional and/or bidirectional communications between the connected components. For example, the communications paths 108 and 110 may be, or include, wired communications paths, wireless communications paths, and/or a combination thereof. In embodiments, communication path 108 and 110 may be, or include, a network or networks. The network may be, or include, any number of different types of communication networks such as, for example, a bus network, a short messaging service (SMS), a local area network (LAN), a wireless LAN (WLAN), a wide area network (WAN), the Internet, a P2P network, and/or the like. In embodiments, the network may include a combination of multiple networks.

**[0039]** The database 106 may be, or include, one or more tables, one or more relational databases, one or more multi-dimensional data cubes, and/or the like. Further, though illustrated as a single component, the database 106 may, in fact, be a plurality of databases 106 such as, for instance, a database cluster, which may be implemented on a single computing device or distributed between a number of computing devices, memory components, or the like. According to embodiments, the database 106 may include information associated with previously planned radiation treatments such as, for example, previously planned radiation treatments that were approved for use on patients by medical personnel, previously planned radiation treatments that were used on patients by medical personnel, and/or the like. In embodiments, treatment outcomes may be included in the database 106. In embodiments, the database 106 includes a medical data database that includes medical data associated with the previously planned radiation treatments. In embodiments, the database 106 includes a processed database configured to store selected data that have been extracted and, in embodiments, transformed (e.g., using a process for determining one or more

characteristics, as described in more detail below), from a medical data database and stored in the processed database.

**[0040]** According to embodiments of the invention, the search component 102 may be any type of search component configured to search the database 106 using one or more features associated with patient data and identifies one or more radiation treatment plans from the database 106 that matches the one or more features associated with the patient data. In embodiments, a radiation treatment plan that matches a feature may refer to, for example, a treatment plan having one or more characteristics (e.g., parameters, features, metrics, aspects, and/or the like) that are identical to, similar to, associated with, correlated with, and/or derivable from the feature (or features), one or more characteristics (e.g., parameters, features, metrics, aspects, and/or the like) of the features, and/or the like. In embodiments, any number of different types of searching techniques and/or algorithms may be utilized to identify matching treatment plans, and may include statistical techniques, pattern-matching techniques, artificial intelligence techniques, and/or the like. In embodiments, for example, the search component 102 may include a search engine, a query module, a database management component, and/or the like. The search component 102 may receive the one or more features associated with the patient data from the user interface 104. That is, for example, a user (e.g., a clinician) may input, via the user interface 104, search criteria including the one or more features associated with the patient data. In embodiments, the search component 102 may receive search criteria from other sources in addition to, or in lieu of, the user interface 104.

**[0041]** The one or more features associated with patient data may include a physics parameter, a treatment type parameter, a patient image parameter, a disease parameter, and/or the like. In embodiments, physics parameters may be, or include, for example, penumbra, aperture, incident angle, beam energy, radiation type, depth of structure, existence of bolus, and/or the like. Treatment type parameters may be, or include, fractionation schedule, treatment margin, number of beams/arcs, interpretation of contours, the clinicians who are part of the team creating the radiation treatment plan, and/or the like. Patient image parameters may be, or include, distance, volume, geometric relationship, importance of structures and surrounding structures, and/or the like. Disease parameters may be, or include, disease stage, prior or post treatment therapy, prior radiation therapy, prior radiation damage to nearby tissue, disease type, disease histology, extent of the disease, prior disease, and/or the like.

**[0042]** According to embodiments, the search component 102 searches the database 106 using at least one of the features, which may include the physics parameters, the treatment type parameters, the patient image parameters, and the disease parameters, and matches the at least one parameter to information (e.g., at least

one treatment plan, at least one feature, at least one parameter, and/or the like) from the database 106. For example, by matching the at least one parameter to one or more previously planned radiation treatments, embodiments of the invention may facilitate selection of the closest matching treatments for providing information to medical personnel and/or facilitating creation of a patient treatment plan.

**[0043]** According to embodiments, the user interface 104 may be configured to present, to a user, one or more parameters associated with the radiation treatment plan (or plans) identified by the search component 102. In embodiments, the user interface 104 may provide read and/or write access to the search component 102 and/or the database 106. In embodiments, the user interface 104 may be, include, and/or be configured to interact with a keyboard, a mouse, a visual display, and/or the like. In embodiments, for example, the user interface 104 may be, or include, text output, print-outs, and/or the like, and/or a graphical user interface (GUI) implemented in hardware, firmware, software, or a combination thereof.

**[0044]** The one or more parameters associated with the treatment plan or plans identified by the search component 102 may include a physics parameter, a treatment type parameter, an image parameter, a disease parameter, and/or the like. In embodiments, physics parameters may be, or include, penumbra, aperture, incident angle, beam energy, radiation type, depth of structure, existence of bolus, and/or the like. Treatment type parameters may be, or include, fractionation schedule, treatment margin, number of beams/arcs, interpretation of contours, the clinicians who are part of the team creating the radiation treatment plan, and/or the like. Patient image parameters related to the patient's anatomy may be, or include, distance, volume, geometric relationship, importance of structures and surrounding structures, and/or the like. Disease parameters may be, or include, disease stage, prior or post treatment therapy, prior radiation therapy, prior radiation damage to nearby tissue, disease type, disease histology, extent of the disease, prior disease, and/or the like.

**[0045]** The illustrative system 100 shown in FIG. 1 is not intended to suggest any limitation as to the scope of use or functionality of embodiments of the present invention. Neither should the illustrative system 100 be interpreted as having any dependency or requirement related to any single component or combination of components illustrated therein. Additionally, any one or more of the components depicted in FIG. 1 may be, in embodiments, integrated with various ones of the other components depicted therein (and/or components not illustrated), all of which are considered to be within the ambit of the present invention. For example, the user interface 104 may be integrated with the search component 102.

**[0046]** FIG. 2 is a block diagram illustrating an extraction system 200 for creating a processed database 202 from a medical data database 204 in accordance with embodiments of the invention. In embodiments, the proc-

essed database 202 and/or the medical database 204 may be, include, be identical to, and/or be similar to database 106 shown in FIG. 1. The processed database 202 and/or the medical database 204 may be, or include, one or more tables, one or more relational databases, one or more multi-dimensional data cubes, and/or the like. Further, though each is illustrated as a single component, the processed database 202 and/or the medical database 204 may, in fact, be a plurality of databases 202, 204 such as, for instance, a database cluster, which may be implemented on a single computing device or distributed between a number of computing devices, memory components, or the like.

**[0047]** According to embodiments, the extraction system 200 includes a database extractor 206 configured to create the processed database 202. The database extractor 206 may be configured to extract information from the medical data database 204 and stores the extracted information in the processed database 202. In embodiments, the database extractor 206 may be configured to process the extracted information before saving it in the processed database 202. For example, the database extractor 206 may be configured to extract certain parameters, compute additional parameters and/or metrics based on the extracted parameters, and store the computed parameters and/or metrics in the processed database 202. In embodiments, non-transitory computer-readable storage media or memory that stores computer-executable instructions, and at least one processor configured to execute the computer-executable instructions may provide the database extractor 206, the medical database 204, and/or the processed database 202.

**[0048]** Additionally, as shown in FIG. 2, the database extractor 206 may be communicatively coupled to the medical data database 204 by communications path 208 and to the processed database 202 by communications path 210. The communications paths 208 and 210 may include any type of communication path suitable for facilitating unidirectional and/or bidirectional communications between the connected components. For example, the communications paths 208 and 210 may be, or include, wired communications paths, wireless communications paths, and/or a combination thereof. In embodiments, communication path 208 and 210 may be, or include, a network or networks. The network may be, or include, any number of different types of communication networks such as, for example, a bus network, a short messaging service (SMS), a local area network (LAN), a wireless LAN (WLAN), a wide area network (WAN), the Internet, a P2P network, and/or the like. In embodiments, the network may include a combination of multiple networks.

**[0049]** The illustrative system 200 shown in FIG. 2 is not intended to suggest any limitation as to the scope of use or functionality of embodiments of the present invention. Neither should the illustrative system 200 be interpreted as having any dependency or requirement related to any single component or combination of components

illustrated therein. Additionally, any one or more of the components depicted in FIG. 2 may be, in embodiments, integrated with various ones of the other components depicted therein (and/or components not illustrated), all of which are considered to be within the ambit of the present invention. For example, the processed database 202 may be integrated with the medical data database 204.

**[0050]** FIG. 3 is a block diagram illustrating another system 300 for facilitating creation of a patient treatment plan in accordance with embodiments of the invention. The system 300 may be used, for example, to facilitate creation of a radiation treatment plan for a cancer patient. In embodiments, non-transitory computer-readable storage media or memory that stores computer-executable instructions, and at least one processor configured to execute the computer-executable instructions may be used to provide one or more components of the system 300.

**[0051]** As shown in FIG. 3, the system 300 includes a search component 302, a user interface 304, and a database 306. The search component 302 may be, include, be identical to, and/or be similar to the search component 102 (shown in FIG. 1); the user interface 304 may be, include, be identical to, and/or be similar to the user interface 104 (shown in FIG. 1); and the database 306 may be, include, be identical to, and/or be similar to the database 106 (shown in FIG. 1), the processed database 202 (shown in FIG. 2), and/or the medical database 204 (shown in FIG. 2). As is further shown in FIG. 3, the system 300 includes a patient data source 308, a feature extractor 310, a prediction component 312, a plan recommendation component 314, a therapy machine control interface 316, a therapy machine 318, and a workstation 320.

**[0052]** The search component 302 may be configured to search the database 306 using one or more features associated with patient data (e.g., that is obtained by the patient data source 308) and identify one or more treatment plans 322 from the database 306 that match the one or more features associated with the patient data. According to embodiments, patient data may include information about a patient 324 such as, for example, one or more physics parameters, treatment type parameters, patient image parameters, disease parameters, and/or the like. In embodiments, the search component 302 searches the database 306 and identifies a number of treatment plans 322 in the database 306 that match the one or more features associated with the patient data. According to embodiments, the search component 302 may receive one or more features associated with the patient data via the patient data source 308, the user interface 304, and/or the like. The search component 302 includes aspects of artificial intelligence (e.g., one or more classifiers, neural networks, and/or other machine-learning techniques) that enable the search component to be dynamically updated based on explicit and/or inferred user preferences, search result trends, and/or the like.

**[0053]** As shown in FIG. 3, the search component 302 is communicatively coupled to the database 306 by communications path 326 and to the prediction component 312 by communications path 328. The prediction component 312 is communicatively coupled to the feature extractor 310 by communications path 330 and the feature extractor 310 is communicatively coupled to the patient data source 308 by communications path 332. The plan recommendation component 314 is communicatively coupled to the prediction component 312 by communications path 334, to the search component 302 by communications path 336, and to the user interface 304 by communications path 338. The user interface 304 is communicatively coupled to the therapy machine control interface 316 by communications path 340 and to the workstation by communications path 342. The therapy machine control interface 316 is communicatively coupled to the therapy machine 318 by communications path 344.

**[0054]** The communications paths 326 - 344 may include any type of communication path suitable for facilitating unidirectional and/or bidirectional communications between the connected components. For example, the communications paths 326 - 344 may be, or include, wired communications paths, wireless communications paths, and/or a combination thereof. In embodiments, communication paths 326 - 344 may be, or include, a network or networks. The network may be, or include, any number of different types of communication networks such as, for example, a bus network, a short messaging service (SMS), a local area network (LAN), a wireless LAN (WLAN), a wide area network (WAN), the Internet, a P2P network, and/or the like. In embodiments, the network may include a combination of multiple networks.

**[0055]** The feature extractor 310 is configured to extract information, including patient image parameters that include geometrical and compositional features related to the anatomy of the patient 324, from patient data obtained by the patient data source 308. The feature extractor 310 provides the extracted information to the search component 302 (e.g., via a communications path not illustrated in FIG. 3), through the prediction component 312, and/or the like. The search component 302 receives one or more features associated with patient data such as, for example, patient image parameters, and uses the received features to search the database 306. In embodiments, patient imaging parameters may include distance, volume, geometric relationship, importance of structures and surrounding structures in the patient 324, and/or the like. In embodiments, features (e.g., patient imaging parameters) may be provided to the search component 302 via the user interface 304.

**[0056]** In embodiments, the patient data source 308 may be, or include, a patient imaging system configured to obtain patient images, from which patient image parameters may be extracted. In such embodiments, the imaging system may obtain an image of the patient 324 and stores the image in a database (e.g., database 306). The feature extractor 310 may be configured to extract

patient image parameters from the image of the patient 324 and provide the extracted patient image parameters to the prediction component 312 and/or the search component 302. According to embodiments, patient imaging systems may use ionizing energy to produce an image of the patient 324. In embodiments, patient imaging systems may use acoustic energy to produce an image of the patient 324. In embodiments, patient imaging systems may use any number and/or combination of these and/or other technologies such as, for example, computed tomography, magnetic resonance imaging, positron emission tomography, x-ray, fluoroscopy, and/or the like. In embodiments, the patient data source 308 may include medical data about the patient such as, for example, current and historical data which may include patient history, and/or the like, and which may be stored one any number of databases. In embodiments, the patient data source 308 may include a source of demographic data, financial data, and/or any other type of data related to the patient. The patient data source 308 may include any number of different types of sources such as, for example, internal databases, memory devices, networks, external servers, third party vendors, a user interface, a machine interface (e.g., an interface to a patient monitoring device), and/or the like.

**[0057]** The prediction component 312 determines at least one metric related to patient treatment and, where the search component 302 identifies a number of treatment plans 322, the prediction component 312 may facilitate selection of one or more of the identified treatment plans 322 using the at least one metric. Metrics is correlated to a radiation treatment dose and may include a predictor of a treatment outcome.

**[0058]** The prediction component 312 determines the at least one metric using information in the database 306, patient data, and/or the like. The prediction component 312 is configured to determine the at least one metric using machine learning techniques. In embodiments, for example, the prediction component 312 may be configured to determine the at least one metric using a neural net, a support vector machine, and/or the like. In embodiments, the at least one metric may include a combination of two or more of the parameters associated with the one or more treatment plans 322 (e.g., treatment plans identified by the search component 302). In embodiments, the prediction component 312 may receive treatment parameters from the user interface 304. In embodiments, the prediction component 312 may receive one or more patient image parameters from the feature extractor 310.

**[0059]** According to embodiments, the plan recommendation component 314 may be configured to recommend at least one of the previously planned radiation treatments (e.g., one or more identified treatment plans 322) to a user. In embodiments, the plan recommendation component 314 may be configured to cause one or more parameters to be inserted (e.g., automatically, in response to a user input, etc.) into a patient treatment plan being created using aspects of embodiments of the

system 300.

**[0060]** The user interface 304 is configured to present one or more parameters, to a user 346, from a treatment plan or plans identified by the search component 302, including, for example, a treatment plan selected using a metric determined by the prediction component 312. In embodiments, the user interface 304 may provide read and/or write access to a patient treatment plan being created for the patient 324. That is, for example, according to embodiments, a user 346, via the user interface 304, may view matching treatment plans identified by the search component 302; view and/or edit a patient treatment plan being created for the patient 324; interact with (e.g., obtain data from, monitor, control, and/or the like) the therapy machine 318; and/or the like. For example, a final radiation treatment plan created for the patient 324 may be provided for configuring the therapy machine 318 via the therapy machine control interface 316. In embodiments, user 346 may interact with the therapy machine control interface 316 via the user interface 304, via another user interface (not illustrated), and/or the like. In embodiments, the therapy machine control interface 316 facilitates interaction with, and/or control of, the therapy machine 318, which is configured to deliver radiation therapy to the patient 324.

**[0061]** In embodiments, the user interface 304 may provide read and/or write access to any one or more components depicted in FIG. 3. In embodiments, the user interface 304 may be, include, and/or be configured to interact with a keyboard, a mouse, a visual display, and/or the like. In embodiments, for example, the user interface 304 may be, or include, a graphical user interface (GUI) implemented in hardware, firmware, software, or a combination thereof.

**[0062]** The illustrative system 300 shown in FIG. 3 is not intended to suggest any limitation as to the scope of use or functionality of embodiments of the present invention. Neither should the illustrative system 300 be interpreted as having any dependency or requirement related to any single component or combination of components illustrated therein. Additionally, any one or more of the components depicted in FIG. 3 may be, in embodiments, integrated with various ones of the other components depicted therein (and/or components not illustrated), all of which are considered to be within the ambit of the present invention. For example, the prediction component 312 may be integrated with the search component 302, the plan recommendation component, and/or the like. Additionally, in embodiments, the user interface 304 may be integrated with the therapy machine control interface 316, and/or hosted by the workstation 320, which, in embodiments, may be integrated with, include, or be included within the therapy machine 318.

**[0063]** According to embodiments, any one or more components of embodiments of the systems described herein (e.g., the system 100, the system 200, the system 300, and/or the like) may be implemented on a computing device 402 that includes a processor 404, a memory 406,

and an input/output (I/O) component 408. Various aspects and/or components of embodiments of the invention may be implemented on a single computing device 402, on multiple computing devices 402, in multiple server instances (e.g., as a server cluster), instantiated within multiple virtual machines, and/or the like. In embodiments, the processor 404 executes various program components stored in the memory 406, which may facilitate creation of a patient treatment plan. In embodiments, the processor 404 may be, or include, one processor or multiple processors. In embodiments, the I/O component 408 may be, or include, one or more devices and/or user interfaces (e.g., the user interface 104, the user interface 304, and/or the like), and may be implemented in hardware, firmware, software, or a combination thereof. Examples of I/O devices include, for example, a monitor, a keyboard, a printer, a disk drive, a universal serial bus (USB) port, a speaker, pointer device, a trackball, a button, a switch, a touch screen, and the like.

**[0064]** The computing device 402 may include any type of computing device suitable for implementing embodiments of the invention. Examples of computing devices include specialized computing devices or general-purpose computing devices such "workstations," "servers," "laptops," "desktops," "tablet computers," "hand-held devices," and the like, all of which are contemplated within the scope of the figures with reference to various components of the embodiments of the invention. In embodiments, a computing device includes a bus that, directly and/or indirectly, couples the following devices: a processor, a memory, an input/output (I/O) port, an I/O component, and a power supply. Any number of additional components, different components, and/or combinations of components may also be included in the computing device. The bus represents what may be one or more busses (such as, for example, an address bus, data bus, or combination thereof). Similarly, in embodiments, the computing device may include a number of processors, a number of memory components, a number of I/O ports, a number of I/O components, and/or a number of power supplies. Additionally any number of these components, or combinations thereof, may be distributed and/or duplicated across a number of computing devices, which may be distributed geographically.

**[0065]** In embodiments, the memory 406 includes computer-readable media in the form of volatile and/or nonvolatile memory and may be removable, nonremovable, or a combination thereof. Media examples include Random Access Memory (RAM); Read Only Memory (ROM); Electronically Erasable Programmable Read Only Memory (EEPROM); flash memory; optical or holographic media; magnetic cassettes, magnetic tape, magnetic disk storage or other magnetic storage devices; data transmissions; or any other medium that can be used to store information and can be accessed by a computing device such as, for example, quantum state memory, and the like. In embodiments, the memory 406 stores computer-executable instructions for causing the processor

404 to implement aspects of embodiments of system components discussed herein and/or to perform aspects of embodiments of methods and procedures discussed herein.

**[0066]** Computer-executable instructions may include, for example, computer code, machine-useable instructions, and the like such as, for example, program components capable of being executed, manipulated, edited, presented, and/or stored, by one or more processors associated with a computing device. Examples of such program components include a search component 410 (which may be, include, be identical to, and/or be similar to the search component 102 depicted in FIG. 1 and/or the search component 302 depicted in FIG. 3); a database 412 (which may be, include, be identical to, and/or be similar to the database 106 depicted in FIG. 1, the processed database 202 depicted in FIG. 2, the medical database 204 depicted in FIG. 2, and/or the database 306 depicted in FIG. 3); a prediction component 414 (which may be, include, be identical to, and/or be similar to the prediction component 312 depicted in FIG. 3); a plan recommendation component 416 (which may be, include, be identical to, and/or be similar to the plan recommendation component 314 depicted in FIG. 3); a feature extractor 418 (which may be, include, be identical to, and/or be similar to the feature extractor 310 depicted in FIG. 3); a patient treatment plan 420 (which may be, include, be identical to, and/or be similar to the patient treatment plans 322 depicted in FIG. 3); and/or the like. Some or all of the functionality contemplated herein may be implemented in hardware, firmware, software, and/or the like.

**[0067]** The illustrative computing device 402 shown in FIG. 4 is not intended to suggest any limitation as to the scope of use or functionality of embodiments of the present invention. Neither should the illustrative computing device 402 be interpreted as having any dependency or requirement related to any single component or combination of components illustrated therein. Additionally, any one or more of the components depicted in FIG. 4 may be, in embodiments, integrated with various ones of the other components depicted therein (and/or components not illustrated), all of which are considered to be within the ambit of the present invention. For example, in embodiments, the processor 404 and the memory 406 may be located remotely with respect to a point of care (e.g., the therapy machine 318 depicted in FIG. 3) that uses the system for creating the radiation treatment plan.

**[0068]** FIG. 5 is a flow diagram depicting an illustrative method 500 for facilitating creation of a patient treatment plan in accordance with embodiments of the invention. In embodiments, aspects of embodiments of the method 500 may be performed, for example, by one or more components of embodiments of the system 100 depicted in FIG. 1, the system 200 depicted in FIG. 2, the system 300 depicted in FIG. 3, and/or the computing device 402 depicted in FIG. 4.

**[0069]** The illustrative method 500 includes receiving

at least one feature associated with patient data (block 502). In embodiments, the at least one feature associated with patient data may be provided through a user interface, a patient data source (e.g., the patient data source 308 depicted in FIG. 3), and/or the like. The at least one feature associated with patient data may include, for example, at least one of a physics parameter, a treatment type parameter, a patient image parameter, a disease parameter, and/or the like. In embodiments, to provide at least one patient image parameter, an imaging system may be configured to obtain an image of the patient from which a feature extractor may extract the at least one patient image parameter.

**[0070]** In embodiments, a physics parameter may include a penumbra, aperture, incident angle, beam energy, radiation type, depth of structure, existence of bolus, and/or the like. A treatment type parameter may include fractionation schedule, treatment margin, number of beams/arcs, interpretation of contours, the clinicians who are part of the team creating the radiation treatment plan, and/or the like. A patient image parameter may include distance, volume, geometric relationship, importance of structures and surrounding structures, and/or the like. Additionally, in embodiments, a disease parameter may include disease stage, prior or post treatment therapy, prior radiation therapy, prior radiation damage to nearby tissue, disease type, disease histology, extent of the disease, prior disease, and/or the like.

**[0071]** As shown in FIG. 5, embodiments of the method 500 include searching a database (e.g., the database 412 depicted in FIG. 4) of previously planned radiation treatments (block 504). In embodiments, for example, a search component (e.g., the search component 410 depicted in FIG. 4) searches the database using the at least one feature associated with patient data. In embodiments, the database includes previously planned radiation treatments that have been approved for use on patients by medical personnel. In embodiments, the database includes previously planned radiation treatments that have been used on patients by medical personnel, such that results and/or outcomes may be included in the database.

**[0072]** Embodiments of the method 500 further include identifying at least one matching treatment plan based on the at least one feature associated with patient data (block 506). For example, in embodiments, the search component may identify the at least one matching treatment plan from the database, which matches the at least one feature associated with patient data. In embodiments, the processor searches the database and identifies a number of matching treatment plans in the database that match the at least one feature associated with patient data.

**[0073]** Embodiments of the method 500 further include determining at least one metric that is correlated to a treatment dose (block 508). In embodiments, for example, a prediction component (e.g., the prediction component 414 depicted in FIG. 4) may be configured to deter-

mine the at least one metric using the database of previously planned treatments. In embodiments, the prediction component may determine the at least one metric using a machine learning technique, a pattern matching technique, a data mining technique, an ensemble technique, and/or the like. The at least one metric may be used, for example, to select one or more matching treatment plans from a number of matching treatment plans identified by the search component.

**[0074]** In embodiments, the method 500 includes presenting, by a user interface, at least one parameter corresponding to the at least one matching treatment plan or plans identified by the search component (block 510). In this manner, embodiments of the invention may facilitate providing a user the opportunity to review the parameter(s) for inclusion in a patient treatment plan that is being created by the user. In embodiments, a plan recommendation component (e.g., the plan recommendation component 416 depicted in FIG. 4) may be used to insert into a patient treatment plan at least one parameter corresponding to the at least one matching treatment plan.

**[0075]** While embodiments of the present invention are described with specificity, the description itself is not intended to limit the scope of this patent. Thus, the inventors have contemplated that the claimed invention might also be embodied in other ways, to include different steps or features, or combinations of steps or features similar to the ones described in this document, in conjunction with other technologies.

## Claims

1. A system for facilitating creation of a radiation treatment plan, the system comprising:

a database (306) of previously planned radiation treatments of other radiation treatment patients; memory (406) that stores computer-executable instructions; and at least one processor (404) configured to execute the computer-executable instructions, which, when executed, cause the at least one processor to provide:

a feature extractor (310) configured to extract one or more features from patient data obtained from a patient data source (308); **characterised in that** the at least one processor is further configured to provide:

a prediction component (312) configured to receive extracted features from the feature extractor and to determine at least one metric correlated to a radiation treatment dose, wherein the prediction component is configured to de-

termine the at least one metric using machine learning, and the prediction component determines the at least one metric using information in the database (306) of previously planned radiation treatments;

a search component (302) configured to receive the at least one metric related to patient treatment from the prediction component, and to identify, based on the at least one metric, at least one matching plan from the database of previously planned radiation treatments; and

a user interface (304) configured to present, to a user, a treatment plan selected using a metric determined by the prediction component.

2. The system of claim 1, wherein the patient data includes imaging data, medical data, patient history, demographic data, and financial data.
3. The system of claim 1 or 2, wherein the one or more features associated with the patient data include at least one of a physics parameter, a treatment type parameter, a patient image parameter, and a disease parameter, and wherein the search component (302) is configured to search the database of previously planned radiation treatments for the one or more features extracted from the patient data.
4. The system of claim 3, wherein the physics parameters include penumbra, aperture, incident angle, beam energy, radiation type, depth of structure, and existence of bolus.
5. The system of claim 3 or 4, wherein the treatment type parameters include fractionation schedule, treatment margin, number of beams or arcs, interpretation of contours, and one or more clinicians creating the radiation treatment plan.
6. The system of any of claims 3 to 5, wherein the patient image parameters include distance, volume, geometric relationship, and importance of structures and surrounding structures.
7. The system of claim 6, wherein the patient image parameter is extracted from a patient image that comprises an imaging scan of the patient produced by one or more of ionizing energy, acoustic energy, computed tomography, magnetic resonance imaging, positron emission tomography, an x-ray, and fluoroscopy.
8. The system of any of claims 3 to 7, wherein the disease parameters include disease stage, prior or post

treatment therapy, prior radiation therapy, prior radiation damage to nearby tissue, disease type, disease histology, extent of the disease, and prior disease.

- 5
9. The system of any of claims 3 to 8, wherein the at least one identified matching plan identified via the search also includes at least one of the physics parameters, the treatment type parameters, the image parameters, and the disease parameters that matches that of the one or more features.
- 10
10. The system of any of the preceding claims, wherein the search component (302) is configured to identify the at least one matching plan by comparing features extracted from the patient data associated with the patient with features extracted from previously planned radiation treatments.
- 15
11. The system of any of the preceding claims, wherein the database (306) of previously planned radiation treatments includes previously planned radiation treatments that have been approved for use on patients by medical personnel, and previously planned radiation treatments that have been used on patients by medical personnel, such that the results or outcomes of the used radiation treatments are included in the database.
- 20
12. The system of any of the preceding claims, wherein the search component (302) is configured to use the at least one metric to facilitate selection of a matching plan from a plurality of identified matching plans.
- 25
13. The system of any of the preceding claims, wherein the at least one processor is further configured to provide a plan recommendation component (314), said plan recommendation component being configured to recommend at least one of the previously planned radiation treatments, and to cause at least one parameter from the at least one matching plan to be inserted automatically into a patient treatment plan recommended for the radiation treatment of the patient.
- 30
14. A computer-implemented method for facilitating creation of a radiation treatment plan, the method comprising:
- 35
- storing previously planned radiation treatments of other radiation treatment patients in a database (306);
- 40
- using a feature extractor (310) to extract one or more features from patient data obtained from a patient data source (308);
- 45
- characterised by:**

using a prediction component (312) to re-

ceive extracted features from the feature extractor and to determine at least one metric correlated to a radiation treatment dose, wherein the at least one metric is determined using machine learning, and the at least one metric is determined using information in the database (306) of previously planned radiation treatments;

using a search component (302) to receive the at least one metric related to patient treatment from the prediction component, and to identify, based on the at least one metric, at least one matching plan from the database of previously planned radiation treatments; and

using a user interface (304) to present, to a user, a treatment plan selected using a metric determined by the prediction component.

15. One or more computer-readable non-transitory storage media storing computer-executable instructions that, when executed, cause at least one processor to provide a system according to any of claims 1 to 13, or to perform a method according to claim 14.

#### Patentansprüche

1. System zum Unterstützen der Erzeugung eines Strahlungsbehandlungsplans, wobei das System Folgendes umfasst:

eine Datenbank (306) zuvor geplanter Strahlungsbehandlungen anderer Strahlungsbehandlungspatienten;

Speicher (406), der computerausführbare Anweisungen speichert; und

mindestens einen Prozessor (404), der konfiguriert ist, die computerausführbaren Anweisungen auszuführen, die, wenn sie ausgeführt werden, bewirken, dass der mindestens eine Prozessor Folgendes bereitstellt:

einen Merkmalsextraktor (310), der konfiguriert ist, ein oder mehrere Merkmale aus von einer Patientendatenquelle (308) erhaltenen Patientendaten zu extrahieren;

**dadurch gekennzeichnet, dass** der mindestens eine Prozessor ferner konfiguriert ist, Folgendes bereitzustellen:

eine Vorhersagekomponente (312), die konfiguriert ist, extrahierte Merkmale von dem Merkmalsextraktor zu empfangen und mindestens eine Metrik, die mit einer Strahlungsbehandlungsdosis korreliert ist, zu bestimmen, wobei die Vorhersagekomponente konfiguriert

ist, die mindestens eine Metrik unter Verwendung von maschinellem Lernen zu bestimmen, und die Vorhersagekomponente die mindestens eine Metrik unter Verwendung von Informationen in der Datenbank (306) zuvor geplanter Strahlungsbehandlungen bestimmt;

eine Suchkomponente (302), die konfiguriert ist, die mindestens eine sich auf Patientenbehandlung beziehende Metrik von der Vorhersagekomponente zu empfangen und, auf der Basis der mindestens einen Metrik, mindestens einen übereinstimmenden Plan aus der Datenbank zuvor geplanter Strahlungsbehandlungen zu identifizieren; und

eine Benutzerschnittstelle (304), die konfiguriert ist, einem Benutzer einen Behandlungsplan zu präsentieren, der unter Verwendung einer von der Vorhersagekomponente bestimmten Metrik ausgewählt wird.

2. System nach Anspruch 1, wobei die Patientendaten Abbildungsdaten, medizinische Daten, Krankengeschichte, demographische Daten und finanzielle Daten beinhaltet.
3. System nach Anspruch 1 oder 2, wobei das eine oder die mehreren mit den Patientendaten assoziierten Merkmale mindestens eines von Folgendem beinhalten:
  - einem physikalischen Parameter, einem Behandlungsartparameter, einem Patientenbildparameter und einem Krankheitsparameter, und wobei die Suchkomponente (302) konfiguriert ist, die Datenbank zuvor geplanter Strahlungsbehandlungen nach dem einen oder den mehreren aus den Patientendaten extrahierten Merkmalen zu durchsuchen.
4. System nach Anspruch 3, wobei die physikalischen Parameter Folgendes beinhalten: Halbschatten, Apertur, Einfallswinkel, Strahlenenergie, Strahlungsart, Strukturtiefe und Vorhandensein eines Bolus.
5. System nach Anspruch 3 oder 4, wobei die Behandlungsartparameter Folgendes beinhalten: Fraktionierungsschema, Behandlungsmarge, Anzahl von Strahlen oder Bögen, Interpretation von Konturen und einen oder mehrere Klinikärzte, die den Strahlungsbehandlungsplan erzeugen.
6. System nach einem der Ansprüche 3 bis 5, wobei

die Patientenbildparameter Folgendes beinhalten: Abstand, Volumen, geometrische Beziehung und Bedeutung von Strukturen und umgebenden Strukturen.

7. System nach Anspruch 6, wobei der Patientenbildparameter aus einem Patientenbild extrahiert wird, der einen Abbildungsscan des Patienten umfasst, der durch eines oder mehrere von Folgendem produziert wird: Ionisierungsenergie, Schallenergie, Computertomographie, Magnetresonanztomographie, Positronen-Emissions-Tomographie, einer Röntgenaufnahme und Fluoroskopie.
8. System nach einem der Ansprüche 3 bis 7, wobei die Krankheitsparameter Folgendes beinhalten: Krankheitsstadium, Vor- oder Nachbehandlungstherapie, Vorstrahlenschäden an umliegendem Gewebe, Krankheitsart, Krankheitshistologie, Ausmaß der Krankheit und frühere Krankheiten.
9. System nach einem der Ansprüche 3 bis 8, wobei der mindestens eine identifizierte übereinstimmende Plan, identifiziert über die Suche, auch mindestens einen von den physikalischen Parametern, den Behandlungsartparametern, den Bildparametern und den Krankheitsparametern, welcher mit dem des einen oder der mehreren Merkmale übereinstimmt, beinhaltet.
10. System nach einem der vorangehenden Ansprüche, wobei die Suchkomponente (302) konfiguriert ist, den mindestens einen übereinstimmenden Plan durch das Vergleichen von Merkmalen, extrahiert aus den Patientendaten, die mit dem Patienten assoziiert sind, mit aus zuvor geplanten Strahlungsbehandlungen extrahierten Merkmalen zu identifizieren.
11. System nach einem der vorangehenden Ansprüche, wobei die Datenbank (306) zuvor geplanter Strahlungsbehandlungen zuvor geplante Strahlungsbehandlungen, die von medizinischem Personal zur Verwendung bei Patienten genehmigt wurden, und zuvor geplante Strahlungsbehandlungen, die von medizinischem Personal bei Patienten verwendet wurden, sodass die Datenbank die Ergebnisse oder Resultate der verwendeten Strahlungsbehandlungen beinhaltet, beinhaltet.
12. System nach einem der vorangehenden Ansprüche, wobei die Suchkomponente (302) konfiguriert ist, die mindestens eine Metrik zu verwenden, um die Auswahl eines übereinstimmenden Plans aus einer Vielzahl von identifizierten übereinstimmenden Plänen zu unterstützen.

13. System nach einem der vorangehenden Ansprüche, wobei der mindestens eine Prozessor ferner konfiguriert ist, eine Planvorschlagskomponente (314) bereitzustellen, wobei die Planvorschlagskomponente konfiguriert ist, mindestens eine der zuvor geplanten Strahlungsbehandlungen vorzuschlagen und zu bewirken, dass mindestens ein Parameter von dem mindestens einen übereinstimmenden Plan automatisch in einen Patientenbehandlungsplan, der für die Strahlungsbehandlung für den Patienten vorgeschlagen wird, eingefügt wird.

14. Computerimplementiertes Verfahren zum Unterstützen der Erzeugung eines Strahlungsbehandlungsplans, wobei das Verfahren Folgendes umfasst:

Speichern von zuvor geplanten Strahlungsbehandlungen anderer Strahlungsbehandlungspatienten in einer Datenbank (306);

Verwenden eines Merkmalsextraktors (310) zum Extrahieren eines oder mehrerer Merkmale aus von einer Patientendatenquelle (308) erhaltenen Patientendaten;

**gekennzeichnet durch:**

Verwenden einer Vorhersagekomponente (312) zum Empfangen extrahierter Merkmale von dem Merkmalsextraktor und zum Bestimmen mindestens einer Metrik, die mit einer Strahlungsbehandlungsdosis korreliert ist, wobei die mindestens eine Metrik unter Verwendung von maschinellem Lernen bestimmt wird und die mindestens eine Metrik unter Verwendung von Informationen in der Datenbank (306) zuvor geplanter Strahlungsbehandlungen bestimmt wird;

Verwenden einer Suchkomponente (302) zum Empfangen der mindestens einen sich auf Patientenbehandlung beziehenden Metrik von der Vorhersagekomponente und zum Identifizieren, auf der Basis der mindestens einen Metrik, mindestens eines übereinstimmenden Plans aus der Datenbank zuvor geplanter Strahlungsbehandlungen; und

Verwenden einer Benutzerschnittstelle (304) zum Präsentieren, für einen Benutzer, eines Behandlungsplans, der unter Verwendung einer von der Vorhersagekomponente bestimmten Metrik ausgewählt wird.

15. Ein oder mehrere computerlesbare, nicht transitorische Speichermedien, die computerausführbare Anweisungen speichern, die, wenn sie ausgeführt werden, bewirken, dass mindestens ein Prozessor ein System nach einem der Ansprüche 1 bis 13 bereitstellt oder ein Verfahren nach Anspruch 14 durchführt.

## Revendications

1. Système pour faciliter la création d'un plan de radiothérapie, le système comprenant :

une base de données (306) de radiothérapies précédemment planifiées d'autres patients de radiothérapie ;

une mémoire (406) qui stocke des instructions exécutables par ordinateur ; et  
au moins un processeur (404) configuré pour exécuter les instructions exécutables par ordinateur, qui, lorsqu'elles sont exécutées, amènent l'au moins un processeur à fournir :

un extracteur de caractéristique (310) configuré pour extraire une ou plusieurs caractéristiques à partir de données de patient obtenues à partir d'une source de données de patient (308) ;

**caractérisé en ce que** l'au moins un processeur est en outre configuré pour fournir :

un composant de prédiction (312) configuré pour recevoir des caractéristiques extraites à partir de l'extracteur de caractéristique et pour déterminer au moins une mesure corrélée à une dose de radiothérapie, où le composant de prédiction est configuré pour déterminer l'au moins une mesure à l'aide d'apprentissage machine, et le composant de prédiction détermine l'au moins une mesure à l'aide d'informations dans la base de données (306) de radiothérapies précédemment planifiées ;

un composant de recherche (302) configuré pour recevoir l'au moins une mesure liée à un traitement de patient à partir du composant de prédiction, et pour identifier, sur la base de l'au moins une mesure, au moins un plan correspondant à partir de la base de données de radiothérapies précédemment planifiées ; et

une interface utilisateur (304) configurée pour présenter, à un utilisateur, un plan de traitement choisi à l'aide d'une mesure déterminée par le composant de prédiction.

2. Système selon la revendication 1, où les données de patient comprennent des données d'imagerie, des données médicales, des antécédents de patient, des données démographiques, et des données financières.

3. Système selon la revendication 1 ou 2, où l'une ou

- plusieurs caractéristiques associées aux données de patient comprennent au moins un paramètre parmi un paramètre de physique, un paramètre de type de traitement, un paramètre d'image de patient, et un paramètre de maladie, et où le composant de recherche (302) est configuré pour effectuer une recherche dans la base de données de radiothérapies précédemment planifiées pour l'une ou plusieurs caractéristiques extraites à partir des données de patient.
- 5
4. Système selon la revendication 3, où les paramètres de physique comprennent la pénombre, l'ouverture, l'angle d'incidence, l'énergie de faisceau, le type de rayonnement, la profondeur de structure, et l'existence de bolus.
- 10
5. Système selon la revendication 3 ou 4, où les paramètres de type de traitement comprennent le programme de fractionnement, la marge de traitement, le nombre de faisceaux ou arcs, l'interprétation des contours, et un ou plusieurs cliniciens créant le plan de radiothérapie.
- 15
6. Système selon l'une quelconque des revendications 3 à 5, où les paramètres d'image de patient comprennent la distance, le volume, la relation géométrique, et l'importance des structures et des structures environnantes.
- 20
7. Système selon la revendication 6, où le paramètre d'image de patient est extrait à partir d'une image de patient qui comprend un balayage d'imagerie du patient produit par un ou plusieurs éléments parmi une énergie ionisante, une énergie acoustique, une tomodensitométrie, une imagerie par résonance magnétique, une tomographie par émission de positrons, une radiographie, et une fluoroscopie.
- 25
8. Système selon l'une quelconque des revendications 3 à 7, où les paramètres de maladie comprennent le stade de la maladie, une thérapie avant ou après traitement, une radiothérapie préalable, un dommage préalable causés par des rayonnements sur un tissu environnant, le type de maladie, l'histologie de la maladie, l'étendue de la maladie, et une maladie préalable.
- 30
9. Système selon l'une quelconque des revendications 3 à 8, où l'au moins un plan correspondant identifié, identifié par le biais de la recherche, comprend également au moins un paramètre parmi les paramètres de physique, les paramètres de type de traitement, les paramètres d'image, et les paramètres de maladie qui correspond à celui de l'une ou plusieurs caractéristiques.
- 35
10. Système selon l'une quelconque des revendications
- 40
- précédentes, où le composant de recherche (302) est configuré pour identifier l'au moins un plan correspondant par comparaison de caractéristiques extraites à partir des données de patient associées au patient avec des caractéristiques extraites à partir de radiothérapies précédemment planifiées.
- 45
11. Système selon l'une quelconque des revendications précédentes, où la base de données (306) de radiothérapies précédemment planifiées comprend des radiothérapies précédemment planifiées qui ont été approuvées pour être utilisées sur des patients par le personnel médical, et des radiothérapies précédemment planifiées qui ont été utilisées sur des patients par le personnel médical, de sorte que les résultats ou conclusions des radiothérapies utilisées sont compris dans la base de données.
- 50
12. Système selon l'une quelconque des revendications précédentes, où le composant de recherche (302) est configuré pour utiliser l'au moins une mesure pour faciliter le choix d'un plan correspondant à partir d'une pluralité de plans correspondants identifiés.
- 55
13. Système selon l'une quelconque des revendications précédentes, où l'au moins un processeur est en outre configuré pour fournir un composant de recommandation de plan (314), ledit composant de recommandation de plan étant configuré pour recommander au moins l'une des radiothérapies précédemment planifiées, et pour amener au moins un paramètre de l'au moins un plan correspondant à être inséré automatiquement dans un plan de traitement de patient recommandé pour la radiothérapie du patient.
14. Méthode mise en oeuvre par ordinateur pour faciliter la création d'un plan de radiothérapie, la méthode comprenant :
- le stockage de radiothérapies précédemment planifiées d'autres patients de radiothérapie dans une base de données (306) ;  
l'utilisation d'un extracteur de caractéristique (310) pour extraire une ou plusieurs caractéristiques à partir de données de patient obtenues à partir d'une source de données de patient (308) ;
- caractérisée par :**
- l'utilisation d'un composant de prédiction (312) pour recevoir des caractéristiques extraites à partir de l'extracteur de caractéristique et pour déterminer au moins une mesure corrélée à une dose de radiothérapie, où l'au moins une mesure est déterminée à l'aide d'apprentissage machine, et l'au moins une mesure est déterminée

à l'aide d'informations dans la base de données (306) de radiothérapies précédemment planifiées ;

l'utilisation d'un composant de recherche (302) pour recevoir l'au moins une mesure liée à un traitement de patient à partir du composant de prédiction, et pour identifier, sur la base de l'au moins une mesure, au moins un plan correspondant à partir de la base de données de radiothérapies précédemment planifiées ; et

l'utilisation d'une interface utilisateur (304) pour présenter, à un utilisateur, un plan de traitement choisi à l'aide d'une mesure déterminée par le composant de prédiction.

15. Un ou plusieurs supports de stockage non transitoires lisibles par ordinateur stockant des instructions exécutables par ordinateur qui, lorsqu'elles sont exécutées, amènent au moins un processeur à fournir un système selon l'une quelconque des revendications 1 à 13, ou à effectuer une méthode selon la revendication 14.

5

10

15

20

25

30

35

40

45

50

55

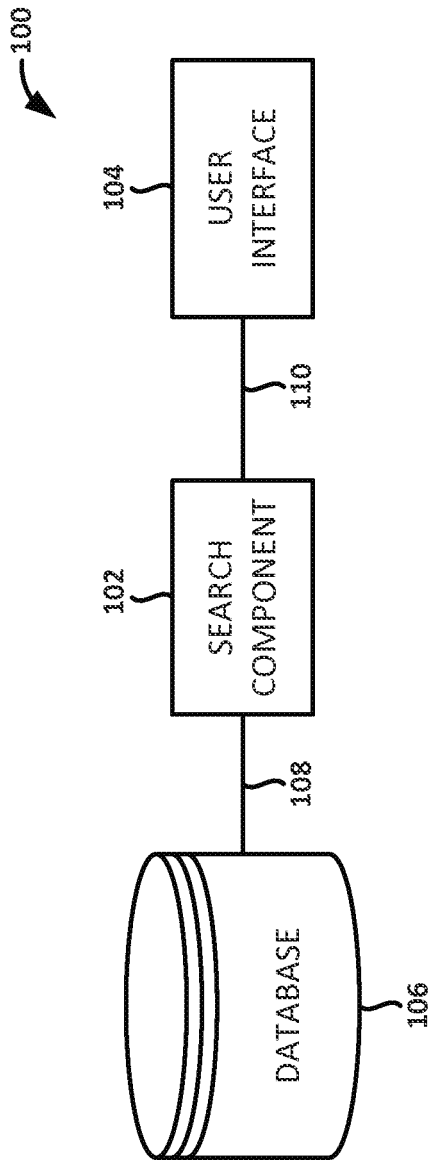

FIG. 1

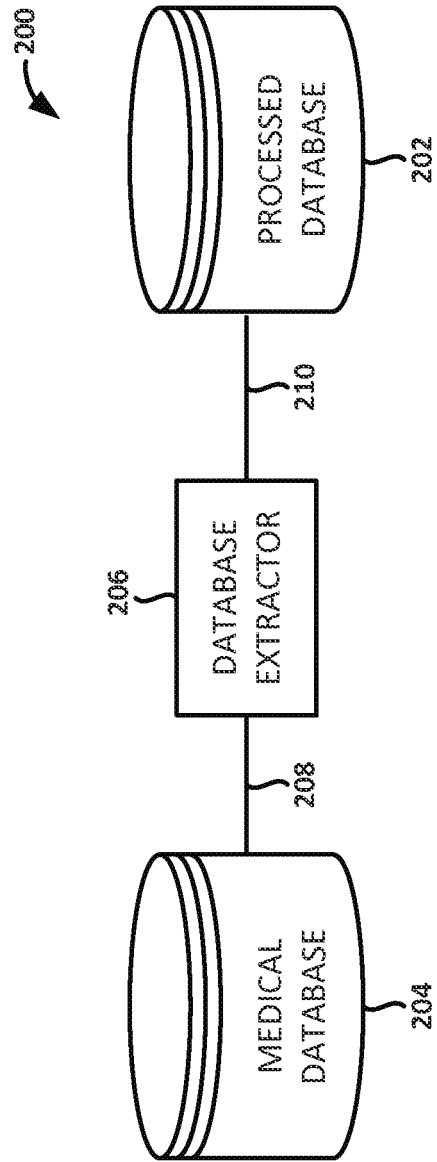

FIG. 2

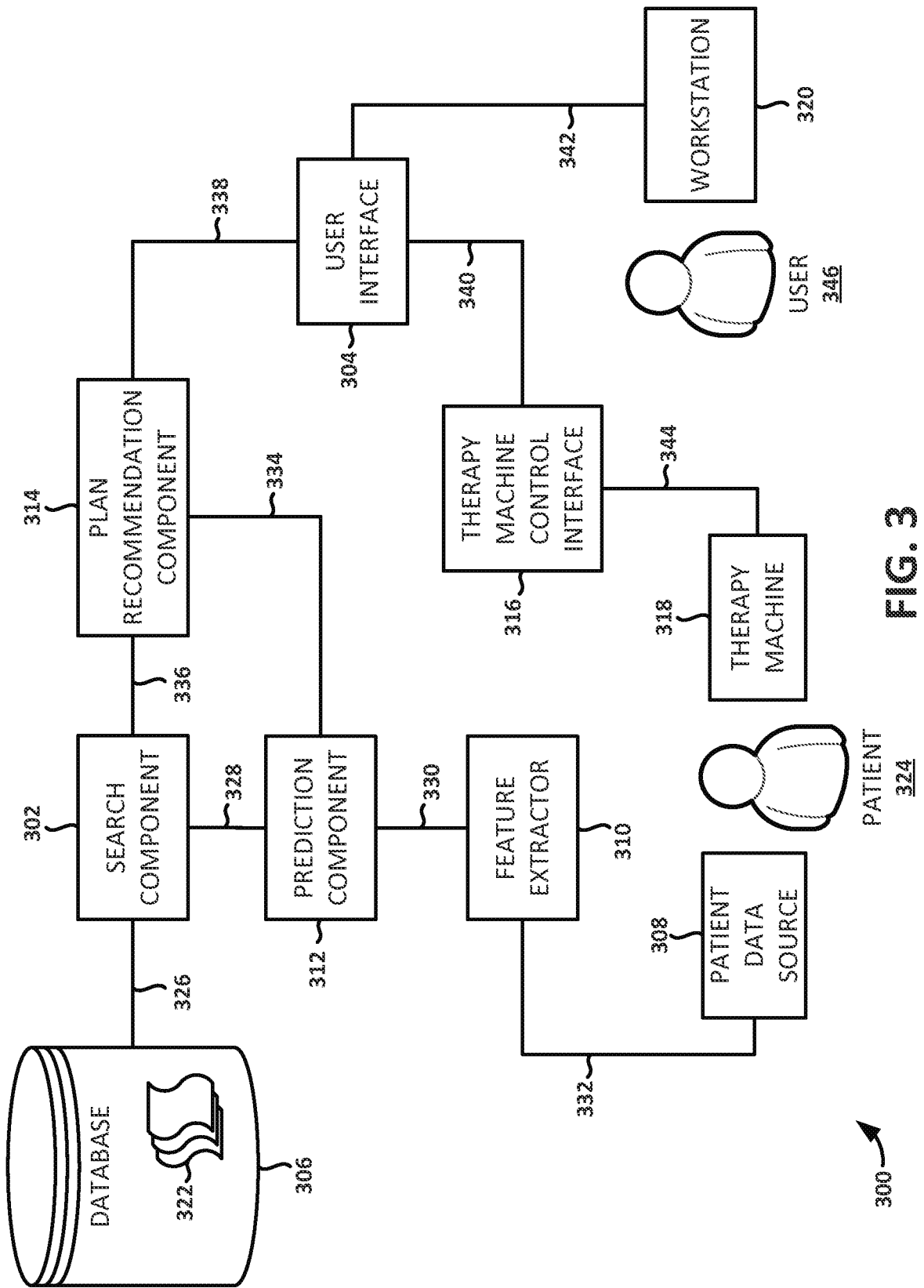

FIG. 3

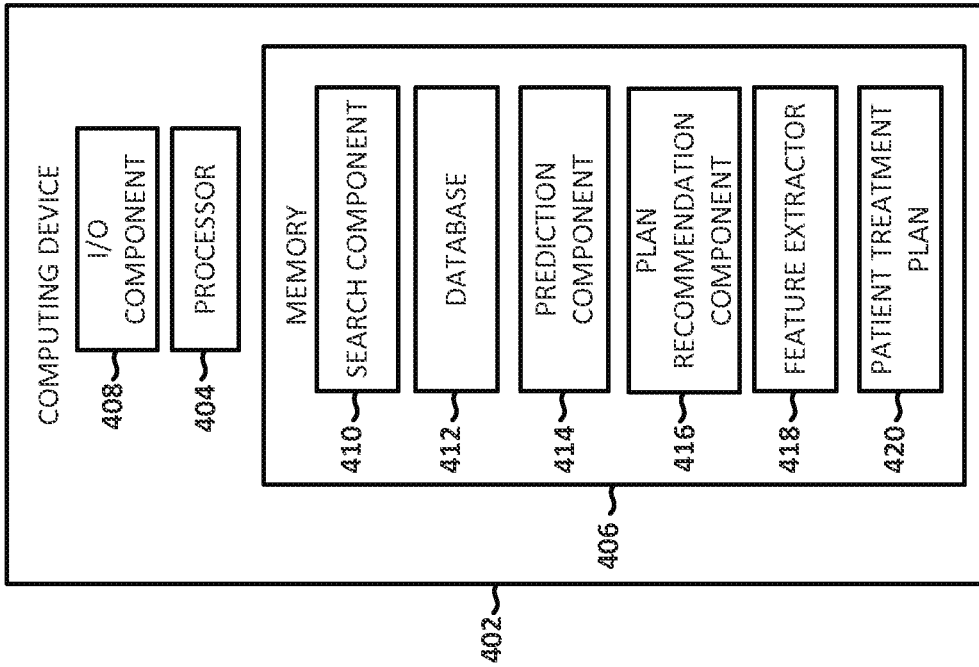

FIG. 4

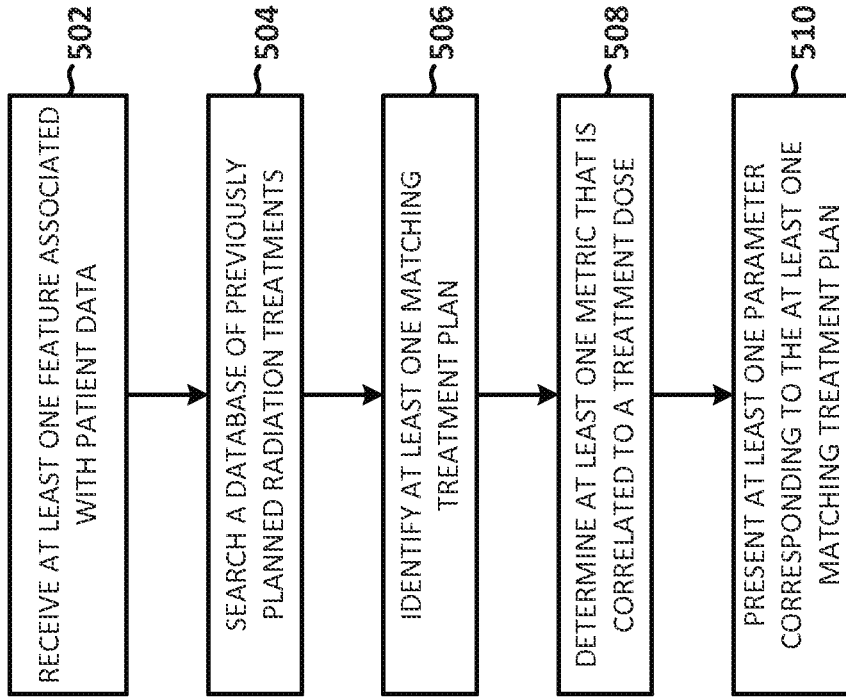

FIG. 5

**REFERENCES CITED IN THE DESCRIPTION**

*This list of references cited by the applicant is for the reader's convenience only. It does not form part of the European patent document. Even though great care has been taken in compiling the references, errors or omissions cannot be excluded and the EPO disclaims all liability in this regard.*

**Patent documents cited in the description**

- WO 2012080906 A [0004]
- US 20110153547 A [0004]

专利名称(译)	多目标放射治疗选择系统和方法		
公开(公告)号	<a href="#">EP3010402A4</a>	公开(公告)日	2017-01-11
申请号	EP2014813453	申请日	2014-06-20
申请(专利权)人(译)	SIRIS MEDICAL , INC.		
当前申请(专利权)人(译)	SIRIS MEDICAL , INC.		
[标]发明人	CARPENTER COLIN DAVIDI RAN MOURLAS NICHOLAS ATWOOD TODD		
发明人	CARPENTER, COLIN DAVIDI, RAN MOURLAS, NICHOLAS ATWOOD, TODD		
IPC分类号	A61B5/00 A61N5/00 G06F19/00 A61N5/10		
CPC分类号	A61N5/1031 A61N5/1039 A61N2005/1041 G16H10/60 G16H20/40 G16H30/20 G16H50/20 G16H50/70 G06F19/3481		
优先权	61/837754 2013-06-21 US 61/877291 2013-09-13 US		
其他公开文献	EP3010402A1 EP3010402B1		
外部链接	<a href="#">Espacenet</a>		

#### 摘要(译)

公开了一种用于促进新的放射治疗计划的创建的系统。该系统包括：用于其他患者的先前计划的放射治疗计划（322）的数据库（306）；特征提取器（320），其被配置为接收与患者的患者数据相关的一个或多个特征，所述患者的患者数据将接受放射治疗以为该患者创建新的放射治疗计划；预测组件（312），其被配置为基于与患者数据相关联的一个或多个特征来预测至少一个度量，该度量包括治疗结果的预测器，其中该预测组件已经使用先前计划的放射治疗计划来学习以预测基于从与先前计划的放射治疗计划相关的患者的患者数据中提取的特征的至少一个度量；搜索组件（302），被配置为搜索数据库并基于至少一个预测度量从先前计划的放射治疗计划的数据库中识别至少一个放射治疗计划，该至少一个放射治疗计划被识别为具有匹配至少一个预测指标；用户界面（304），被配置为向用户呈现至少一个识别的放射治疗计划或与至少一个识别的放射治疗计划相关联的一个或多个参数，作为创建新放射治疗计划的推荐。