

(19)



(11)

**EP 2 793 643 B1**

(12)

**EUROPEAN PATENT SPECIFICATION**

(45) Date of publication and mention of the grant of the patent:  
**13.05.2020 Bulletin 2020/20**

(51) Int Cl.:  
**A45D 44/00 (2006.01) A61B 5/103 (2006.01)**  
**A61B 5/00 (2006.01)**

(21) Application number: **12824713.7**

(86) International application number:  
**PCT/IB2012/057558**

(22) Date of filing: **20.12.2012**

(87) International publication number:  
**WO 2013/093851 (27.06.2013 Gazette 2013/26)**

**(54) METHOD FOR DELIVERING COSMETIC ADVICE**

VERFAHREN ZUR BEREITSTELLUNG KOSMETISCHER TIPPS

PROCÉDÉ POUR DÉLIVRER DES CONSEILS COSMÉTIQUES

(84) Designated Contracting States:  
**AL AT BE BG CH CY CZ DE DK EE ES FI FR GB GR HR HU IE IS IT LI LT LU LV MC MK MT NL NO PL PT RO RS SE SI SK SM TR**

(30) Priority: **23.12.2011 FR 1162435**  
**30.01.2012 US 201261592405 P**  
**11.05.2012 US 201261645859 P**

(43) Date of publication of application:  
**29.10.2014 Bulletin 2014/44**

(73) Proprietor: **L'Oréal**  
**75008 Paris (FR)**

(72) Inventors:  
• **LUCET- LEVANNIER, Karine**  
**92500 Reuil-Malmaison (FR)**

• **CHRISTIAENS, François**  
**94100 Saint Maur Des Fosses (FR)**

(74) Representative: **Nony**  
**11 rue Saint-Georges**  
**75009 Paris (FR)**

(56) References cited:  
**WO-A1-2008/108760 WO-A2-2008/038135**  
**WO-A2-2008/038135 WO-A2-2009/013687**  
**DE-A1- 19 612 531 US-A- 5 365 068**  
**US-A1- 2007 058 860**

• **A. CHARDON, I. CRETOIS, C. HOURSEAU: "Skin colour typology and tanning pathways", INTERNATIONAL JOURNAL OF COSMETIC SCIENCE, no. 13, 1991, pages 191-208, XP002683806, cited in the application**

**EP 2 793 643 B1**

Note: Within nine months of the publication of the mention of the grant of the European patent in the European Patent Bulletin, any person may give notice to the European Patent Office of opposition to that patent, in accordance with the Implementing Regulations. Notice of opposition shall not be deemed to have been filed until the opposition fee has been paid. (Art. 99(1) European Patent Convention).

## Description

**[0001]** The present invention relates to skin pigmentation and the provision of advice regarding the photoprotection to be applied and/or to individual skin colors obtainable via tanning.

**[0002]** The idea of classifying various skin types according to their sensitivity to solar radiation has been around for a long time. Thus, as early as 1977 the Fitzpatrick classification differentiated between six phototypes I to VI ranging from Caucasian skin that does not tan to highly pigmented African skin.

**[0003]** Subsequently, a more precise classification was suggested by A. Chardon, I. Cretois, C. Hourseau in Skin color typology and suntanning pathways International Journal of Cosmetic Science 13, 191-208 (1991). This classification is based on knowledge of the CIE (1976)  $L^*a^*b^*$  color coordinates of the skin and on the calculation of the individual typology angle ( $ITA^\circ$ ) =  $(\arctan((L^*-50)/b^*)) \cdot 180/\pi$ . According to this classification, a high  $ITA^\circ$  angle characterizes a light skin and a low angle a more pigmented skin.

**[0004]** It is also known that there is a relationship between the skin color obtained while tanning and the skin type. A. Chardon demonstrated, in the above article, that it is possible to define tanning pathways, i.e. to determine the change in the  $L^*$  and  $b^*$  components for a given skin type under increasing sun exposure.

**[0005]** Moreover, the dangers of exposure to the sun are now well known and there is a tendency towards more frequent use of photoprotective compositions. However, the user is confronted, when they decide to use a photoprotective composition and if they would like to tan rapidly, with the problem of choosing the sun protection factor.

**[0006]** Specifically, exposure to the sun results, except for the lightest skin, in the production of melanin, which makes the skin less sensitive to subsequent exposure. If the user employs a photoprotective composition with too high a factor, their skin will tan very slowly or they will not tan at all and the individual will possibly be unhappy with how little they have tanned, especially when they have a limited time to spend exposed to the sun, which is the case, for example, when on vacation. If, in contrast, the user employs a photoprotective composition with too low a factor, they run the risk of getting sunburnt and of no longer being able to expose themselves to the sun for a certain period of time, which may force them to abandon certain activities.

**[0007]** To help the consumer make a choice, it is known to inform them, on the day or beforehand, of the UV radiation strength in order to encourage them to use a photoprotective composition with a higher factor when the UV radiation is stronger.

**[0008]** However, knowing the UV index does not completely simplify the choice of photoprotective composition to apply, because other factors need to be taken into account, such as phototype and the degree of tanning already obtained.

**[0009]** Devices, equipped with a UV-radiation sensor, have also been proposed in order to provide the user with this information at any moment.

**[0010]** The Applicant has moreover proposed in publication FR 2 937 511 to equip a bottle comprising a plurality of compartments with an adjustment system and a UV-radiation sensor, in order to automatically deliver, to the user, a photoprotective composition having a protection index suited to the ambient UV radiation.

**[0011]** The Applicant has also proposed, in application US 2011/0247718 A1, a bottle equipped with a data receiver allowing a mixing system to be automatically set to deliver a photoprotective composition having the factor considered to correspond best to the needs of the user.

**[0012]** These proposals are not completely satisfactory solutions to the problem of choosing the protection factor because, on the one hand, the proposed systems are relatively complex and expensive, and on the other hand, they still do not accurately take the level of tan of the individual into account.

**[0013]** Other systems exist, which carry out measurements on the skin in order to give advice on the protection to be used, especially depending on the time exposed to the sun and on the sensitivity of the skin. Thus, patent US 8 044 363 discloses a portable device for detecting UV which includes a reflectometer or colorimeter for measuring the skin type. Several measurements may be carried out on the body in order to calculate an average or to retain the measurement that is representative of the greatest sensitivity to the sun.

**[0014]** Such a device does not inform the user of the individual skin color that they are liable to obtain by tanning. In addition, such a device having a specific use may prove to be relatively expensive to manufacture, thereby limiting its use.

**[0015]** Finally, other existing systems, in order to give advice, use a questionnaire to determine skin type, the answers to this questionnaire sometimes being quite subjective or imprecise as they, for example, relate to childhood memories.

**[0016]** US 2003/0067545 A1 discloses a spherical chamber containing apertures in which a person places their face. The chamber allows the face to be illuminated with diffuse light. An adhesive reference chart may be placed on the forehead of this person, during a process for calibrating the color of one or more cameras.

**[0017]** US 2003/0064350 A1 suggests giving personalized advice especially depending on the location of the individual to be advised.

**[0018]** US 2007/0058860 discloses a method for generating a product recommendation which takes into account the varying lighting conditions that influences the perception of the skin color by applying a color correction function.

**[0019]** DE 196 12 531 discloses a method in which an image is acquired by a camera and then transferred from the

camera to a computer system for analysis.

**[0020]** WO 2009/013687 teaches a method for generating a product recommendation on the basis of perception of different skin tones under varying lighting conditions.

5 **[0021]** WO 2008/108760 discloses a computer implemented method for recommending a product based upon skin color estimated from a captured image. In said method a colour is acquired from a region of the body of an individual using a device equipped with a colour camera and by placing a colour reference chart in the field of said camera during acquisition.

**[0022]** WO 2008/038135 discloses a device for determining the sun protection factor by matching with naked eyes the skin of an individual with printed images of different skin types.

10 **[0023]** There is a need to make it easier for as many people as possible to access personalized advice regarding the photoprotection to use in a given environment, especially depending on the pigmentation that it is desired to obtain and/or the pigmentation that has already been obtained.

**[0024]** In addition, many people would like to know which natural skin colors are likely to be damaged by the pigmentation process, in order to help decide, for example, between a relatively long exposure to the sun and/or the use of compositions intended to temporarily modify the color of the skin and giving the skin a color obtainable via the pigmentation process.

15 **[0025]** The invention meets all or some of these requirements by virtue of a cosmetic method according to claim 1.

**[0026]** The description also discloses a cosmetic method, especially for providing help choosing a photoprotective composition or a product intended to temporarily modify the color of the skin, in which:

20 a) a color is acquired from a region of the body of an individual, by using a device equipped with a color camera and by placing a color reference chart in the field of said camera during the acquisition; and

b) using the device, and the color acquired in a), and optionally knowledge of the tanning pathways of various skin colors, at least one indication is delivered concerning skin type and/or an indication is delivered concerning at least one skin color obtainable by the individual via the pigmentation or depigmentation process and/or at least one indication is delivered concerning photoprotection, especially UV-A and/or UV-B photoprotection, and/or application or administration of a product intended to temporarily modify the color of the skin, the indication(s) preferably being delivered automatically.

30 **[0027]** The expression "pigmentation obtained" is, unless otherwise stated, understood to mean the result obtained from tanning.

**[0028]** The expression "pigmentation to be obtained" is, unless otherwise stated, understood to mean the result to be obtained from tanning.

**[0029]** The expression "pigmentation process" is, unless otherwise stated, understood to mean the tanning process.

35 **[0030]** Knowledge of the tanning pathway is not required in order to indicate the skin type but it is necessary to determine the one or more skin colors obtainable via the pigmentation process.

**[0031]** In a simplified variant the indication to be given concerning photoprotection may be based on skin type alone, but preferably the indication also takes account of additional information as detailed below, in order to provide precise and personalized advice.

40 **[0032]** By virtue of the invention, it is possible to carry out a precise measurement of the color of the skin using the low-cost color cameras of devices that are widely available to the public at the present time, such as smart phones or tablet computers.

**[0033]** In addition, these devices have a screen, memory, and sufficient processing capacity to rapidly run algorithms allowing an indication to be delivered concerning the one or more skin colors obtainable via the pigmentation process and/or the photoprotection to be applied.

45 **[0034]** Thus, the user may learn, by virtue of the invention, what their skin type is, and the device may be used to suggest photoprotection suitable for their sensitivity to UV rays.

**[0035]** In addition, the invention allows the sensitivity of the skin to the sun to be diagnosed empirically, and thus to avoid errors due to the use of a questionnaire.

50 **[0036]** The user may also learn what change in the color of their skin they can expect, and decide, depending on this information, on the result that they would like to obtain from the pigmentation process. The device may then provide advice on the photoprotection that should be used, for example, to obtain this result while screening as much as possible of the surplus UV radiation that is not needed to obtain this result.

**[0037]** As mentioned above, at least one indication concerning the application or administration of a product intended to temporarily modify the color of the skin may be delivered in step b).

55 **[0038]** Said product may be an oral or topical composition. Said product is, in a preferred variant, a food supplement and/or a self-tanning product. The product is a pro-pigmenting, depigmenting or anti-pigmenting product.

**[0039]** The invention also makes it possible, if it is desired, to provide an indication concerning, and especially to propose to the consumer, a makeup product to be applied. This makeup product may provide protection from the sun,

and, optionally, it may be a colored solar protection product allowing a natural skin color to be obtained, i.e. a skin color lying on the tanning pathway of the user, or else allowing an unnatural skin color to be obtained in the case of very light skins that do not tan.

5 [0040] The use of a lightening composition may also be proposed to the user in step b), for example when said user desires to obtain a less pigmented skin color.

[0041] Advantageously, step a) is carried out at least once on skin that is not exposed to the sun. The method may comprises a step c) consisting in carrying out a second acquisition on another skin region, liable to have already been exposed to the sun, using the device and preferably again placing the color reference chart in the field of the camera.

10 [0042] The device may optionally be programmed to allow the user to indicate on which part of the body or face the acquisition is carried out, and this information and the result of the corresponding color measurement may be stored in the device, or on a remote server.

[0043] Knowledge of the part of the body or face used for the measurement may, if required, allow the colors obtainable via the pigmentation process to be predicted with greater precision by allowing tanning pathways specific to each region of the body to be employed.

15 [0044] Information concerning the actual pigmentation and/or photoprotection level already obtained by a region of the body or face, based on the color acquisitions carried out in a) and in c) and on knowledge of the tanning pathway for the unexposed skin color determined in a), may be delivered automatically via the device.

[0045] Thus, the user may decide to choose a potential photoprotective product depending on how much they would like to tan. For example, the user may decide to apply a photoprotective product in order to preserve an actual skin color, or because continued exposure to the sun is not expected to lead to a rapid and observable change in the color of their skin, there thus being no reason for additional exposure which in addition runs the risk of accelerating photoaging of the skin.

20 [0046] The device may provide the user with information regarding the photoprotection to use for each region of their body or face, the user simply having to measure the color of this region, preferably by using the color reference chart each time.

25 [0047] The device may be set up to ask the user to enter information on the length of time they will be staying in a given location, and the indication regarding photoprotection may be delivered by the device depending on this information regarding length of stay, for example after a server and/or local weather sensor, which the device may connect to automatically, have/has been consulted.

30 [0048] The sensor may deliver a result of a measurement of at least one item of weather-related data, preferably the ambient UV radiation strength. Using the result of the measurement delivered by the sensor advantageously removes any doubt regarding a weather forecast. All that is required is for the device to be connected, physically and/or by way of a data-exchange network, to said sensor. Details will be given below regarding various arrangements that can be envisioned for the sensor and device.

35 [0049] If required, the device may be set up to gather information regarding location and length of stay from an electronic calendar of the user, or from a service-provider site containing this information.

[0050] The information concerning the photoprotection to use may be sent to the electronic calendar of the user, for example to Google calendar or icalendar, in addition to being displayed on the screen of the device.

40 [0051] The device may be set up to deliver an indication regarding the photoprotection to use, for example, by displaying the SPF factor to use and/or the trade name of the composition to use and/or the UV-A protection factor, indicated in the form of abbreviations, logos, and/or a scale, optionally a color scale, and/or a factor representing protection from a natural and/or artificially generated part of the electromagnetic spectrum. The SPF factor to be used each day may be displayed for a number of days to come, for example the next three days at least. This information may be refreshed periodically as, for example, more accurate weather forecasts become available. If required, the device is informed of the brand of the photoprotective composition the user has at their disposal, and the indication delivered regarding the photoprotection to apply and/or the recommended length of exposure takes account of the UV screening properties of this photoprotective composition, which the user knows or may find out by accessing a database. If required, the screening properties are indicated by a code on packaging of the photoprotective composition, which code the device is able to decipher.

50 [0052] The device may also be set up to control a device such as the intelligent bottle described in publication US 2011/0247718 A1 by the Applicant, which bottle is capable of receiving signals that specify the mixture to be produced, in order to obtain a photoprotective composition with the desired photoprotection factor. In this case, use may be made of the capacity of the device to communicate wirelessly, for example via a Wi-Fi or Bluetooth connection.

55 [0053] Advantageously, the device is set up to ask the the user to enter information concerning the desired pigmentation level and/or skin color to be obtained and to deliver, at least based on this information, and preferably also based on knowledge of the weather to come, an indication regarding the photoprotection to apply. To help the user select the desired pigmentation level to be obtained, a number of skin colors may be displayed on the screen of the device, these skin colors corresponding to colors obtainable by the user via the pigmentation process, to within the color shift of the

screen.

5 [0054] In order to minimize this color shift, the screen color may be calibrated. This calibration may advantageously be carried out at a point of sale of photoprotective compositions and/or products intended to temporarily modify the color of the skin. The user may also be encouraged, at the same point of sale, to download software that will subsequently allow them to measure the color of their skin, in the context of the implementation of the process according to the invention. The software which is downloaded may contain data for calibrating the screen. As a variant, the user calibrates the screen color themselves, using existing tools available from other sources. By way of example, mention may be made of the application "SpyderGallery™" and the probe "Spyder3™" from Datacolor allowing the color of an iPad screen to be calibrated.

10 [0055] Even when an uncorrected color shift does exist, the screen may provide the user with useful information, especially by allowing them to compare the displayed colors, which correspond to various levels obtainable via the pigmentation process. The actual skin color of the user may also be displayed and compared. Thus, it will be understood that the indication concerning the skin color obtainable via the pigmentation process capable of being delivered in step b) must not be understood as limited in scope and encompasses situations where the color displayed corresponds to the actual color to within the ability of the screen to render the color accurately.

15 [0056] The device may ask the user to enter information regarding the desired skin color and deliver information on how it may be obtained, at least depending on the acquisition carried out in a) and preferably also depending on the acquisition carried out in c).

20 [0057] When the user is allowed to select a skin color, the device may be set up to determine, taking into account the items of information it has at its disposal, whether this color will be obtained, via the pigmentation process, by the end of a given period. For example, the device may take into account the length of stay in a given location, and the weather forecast for this location, in order to inform the user that the desired skin color will not be obtained by the end of the stay. In this case, the device may be set up to suggest using at least one composition intended to temporarily modify the color of the skin, especially a makeup, self-tanning, pro-pigmenting, depigmenting or anti-pigmenting product allowing the desired color to be obtained.

25 [0058] The device may also be used when the pigmentation obtained is gradually being lost once exposure to the sun has ceased, to measure, daily for example, the color of the skin and deliver advice to the user regarding a product intended to temporarily modify the color of the skin, to be applied or administered in order to preserve a natural skin color that is obtainable via the pigmentation process, especially a color selected by the user. In this case, the device may suggest, to a user having lost all or some of their previously acquired pigmentation, applying a makeup or pro-pigmenting composition, so that they may regain a color obtained previously via the pigmentation process.

30 [0059] Optionally the device may control an intelligent bottle such as that described in publication US 2011/0247718 A1, for example containing a neutral base and one or more coloring agents, in order to deliver a foundation with the color most suited to obtaining the desired appearance, especially in order to reproduce a natural color obtainable via the pigmentation process.

35 [0060] In one variant, the intelligent bottle controlled by the device delivers a self-tanning composition having a variable concentration, defined by the device, so as to obtain the desired skin color.

[0061] The device may also control an applicator that allows color to be varied, for example an airbrush or an ultrasonic or electrostatic spray gun, so that this applicator delivers the color allowing the result desired by the user to be obtained.

40 [0062] The device may have the color characteristics of a plurality of compositions intended to temporarily modify the color of the skin, especially makeup, and capable of being used to obtain an optionally tanned skin color, stored in memory, or may be able to access a database containing this information.

[0063] All the calculations can be performed by the device and all the data required to perform these calculations, and the information stored in memory following the various measurements, may be contained in the device.

45 [0064] However, as a variant, some of the calculations may be performed by a remote server external to the device, to which the latter transmits the information required to perform these calculations, before receiving in turn the result of these calculations. The ability of the device to communicate is then advantageously used to exchange this information.

[0065] As another variant, data is collected and/or saved on a remote server, while a program is being run on the device.

50 [0066] The device is used to measure the color of bare skin, but it may also be used to measure the color of madeup skin in order to provide the user with information concerning, for example, how suited an applied makeup composition is to their skin color. For example, the device may signal to the user that the makeup that they are wearing gives their skin a color that is relatively different, colorimetrically, from a skin color obtainable via the pigmentation process. This information is, for example, delivered in the form of a numerical value and/or indications regarding ways in which to modify the color of the applied makeup in order to obtain a more natural skin color. This may help the user determine which foundation is likely to most suit their natural skin color.

55 [0067] The device may also ask the user about the cosmetic products they have at their disposal and, knowing the colorimetric properties of these compositions and the skin color of the user, generate makeup advice allowing them to match their natural skin color to a greater or lesser extent. The device may especially signal which product will allow a

color most closely resembling a natural skin color to be obtained, by choosing, for example, from a range of products indexed by the device and/or by suggesting a mix of various indexed products, or by specifying commonly available food products and/or the proportions of mixtures of these products.

**[0068]** The invention also relates to a method, in which a quantity representative of  $a^*$  (position on the red/green axis) is measured before and after exposure to the sun, and, depending on the difference, the presence or absence of erythema is determined. The measurement of  $a^*$  may be carried out in step a) or c).

**[0069]** Another subject of the invention is a method in which, if erythema is detected, the device delivers a warning message and/or takes the erythema into account when recommending the photoprotective composition to apply.

**[0070]** The description also discloses, especially for implementing the method according to the invention, comprising a window through which an acquisition of the color of the skin may be carried out, the chart preferably comprising at least three different gray levels and at least three different colors, and the chart also preferably being produced using non-metameric inks. The potential residual metamerism of the chart preferably results in an error in the measurement of the color of the skin under illuminants D65, A and CWL, which causes the device to consider that the skin is lighter than it actually is. The chart is described in more detail below.

**[0071]** The invention also relates to a computer software package according to claim 15. The description also discloses, for implementing the method, comprising data allowing, when loaded, preferably by way of a connection to a remote server, into a device, such as a smart phone or a tablet computer, equipped with a camera:

- the acquisition of the image of a chart placed on the skin to be controlled;
- the color reference chart and a region of skin adjoining this chart to be recognized;
- the acquisition units of the device to be colorimetrically calibrated via knowledge of the absolute color coordinates of the chart; and
- an indication concerning skin type and/or an indication concerning at least one individual skin color obtainable via the pigmentation or depigmentation process and/or an indication concerning application or administration of a product intended to temporarily modify the color of the skin and/or a photoprotection to be applied, to be generated, based on knowledge of the skin color measured in the image and optionally on knowledge of tanning pathways. This skin color may optionally be read from a scale bar comprising a skin-color scale, provided on the packaging of a cosmetic product of a brand indicated by the software package.

**[0072]** Such a program is, for example, downloaded from sites such as Apple Store, Windows Store, or Android Market, or is provided on an optical disk or electronic memory.

**[0073]** The invention may be better understood on reading the following detailed description of non-limiting illustrative embodiments thereof and on examining the appended drawings, in which:

- figure 1 shows, schematically, an example of a system for implementing the invention;
- figure 2 shows the color reference chart in isolation;
- figure 3 shows an exemplary packaging and distribution unit provided with a chart;
- figure 3a shows an assembly comprising a protective cover, a device and a chart;
- figures 4 and 5 show examples of the format in which the charts may be packaged;
- figure 6 is a flow chart illustrating various steps in an example of a method according to the invention;
- figure 7 shows an example of a tanning pathway as represented by A. Chardon;
- figures 8A to 8G show examples of screen pages that may be displayed when the program is being run by the device;
- figure 9 shows an exemplary correlation between  $ITA^\circ$  angle and biologically effective dose; and
- figure 10 illustrates how an intelligent bottle may be controlled using the device.

**[0074]** The system 1 according to the invention, shown in figure 1, comprises a portable device 20 and a color reference chart 30, which will now be described in succession in detail.

#### Color reference chart

**[0075]** A nonlimiting example of a chart is shown in figure 2.

**[0076]** The chart comprises at least one zone, and preferably a plurality of zones, the color coordinates of which are known with precision in a reference color space, preferably the CIE (1976)  $L^*a^*b^*$  color space.

**[0077]** Preferably, the chart is produced in order to be as insensitive as possible to different illuminants, and may thus be produced using dyes that are weakly metameric or non-metameric, especially with respect to standard CIE illuminants D65, A and CWL.

**[0078]** Preferably, the color reference chart comprises at least three different gray levels  $G_1, \dots, G_n$  and at least three different colors  $C_1, \dots, C_m$ , and preferably at least six gray levels and six colors, for example two flesh colors, two blues,

a red and a green.

[0079] The gray levels and colors may each take the form of a sector, all the sectors together advantageously forming a complete circumference.

[0080] The sectors or other colored or gray portions may adjoin or be separated by black strips, for example.

[0081] As illustrated in figure 2, the chart preferably comprises a window 31 which is advantageously located centrally. The acquisition of the color of the skin is carried out using the device by observing the skin, preferably through the window 31.

[0082] The external outline of the chart is for example substantially circular, as illustrated, but the invention is not limited to a chart having a particular shape, and the chart may have a polygonal shape, for example.

[0083] The largest dimension of the chart, for example its external diameter in the case of a circular chart, as illustrated, is for example smaller than or equal to 5 cm, and is preferably between 2 and 4 cm, so that it can be easily positioned on various regions of the body or face.

[0084] The window 31 is preferably larger than 0.5 cm<sup>2</sup> in size, and is preferably between 1 and 5 cm<sup>2</sup> in size, in order that a large enough area of skin is visible for an accurate measurement to be possible.

[0085] The window 31 may be bounded by a circular aperture, as illustrated; however, as a variant, the window may have a noncircular outline, for example having a polygonal outline or an outline with some other shape.

[0086] The color reference chart 30 may be produced on any medium 32, but is preferably produced on a flexible medium, for example on paper, by printing. The inks used are preferably non-metameric inks, so as to make the chart sufficiently illuminant-insensitive, especially to illuminants D65, A, and CWL. The medium 32 is preferably opaque or white before printing, which may be carried out by flexographic, offset or digital printing. The medium may be made of paper, cardboard or preferably of a synthetic material such as a polyolefin, especially PE or PP. The thickness used will for example be from 30 μm to 2 mm.

[0087] In one embodiment, the color L\*a\*b\* coordinates of the various regions of the chart are the following:

ColorChecker

No.	Name	L*	a*	b*	color
1	dark skin	37.986	13.555	14.059	
2	light skin	65.711	18.13	17.81	
3	blue sky	49.927	-4.88	-21.925	
4	red	42.101	53.378	28.19	
5	green	55.261	-38.232	31.37	
6	blue	28.778	14.179	-50.297	
7	white	96.539	-0.425	1.186	
8	gray 1	81.257	-0.638	-0.335	
9	gray 2	66.766	-0.734	-0.504	
10	gray 3	50.867	-0.153	-0.27	
11	gray 4	35.656	-0.421	-1.231	
12	black	20.461	-0.079	-0.973	

[0088] It has been demonstrated that it is possible to produce the chart in such a way that the error in the ITA° angle calculation, resulting from the variation in the skin color measured as a function of the illuminant, remains relatively small. Preferably, this variation ΔE is smaller than 2 when an inspection is carried out with a spectrophotometer.

[0089] In particular, it is advantageous for the difference between the ITA° measured with the camera and the chart to be smaller than the ITA° calculated using a more precise spectrophotometer measurement. Thus, the error leads to overprotection of the skin rather than underprotection, which is advantageous with respect to decreasing the risk of erythema.

[0090] That side of the chart to be applied to the skin may be adhesive, for example by virtue of the use of a medium coated with a pressure-sensitive adhesive. The adhesive is hypoallergenic. As a variant, the side making contact with the skin is non-slip, by virtue for example of the use of a rough, for example cellular, material. A notch or tab may be provided, if required, to make unsticking the chart easier.

[0091] If required, the chart may be washable, in order to be reusable.

[0092] The chart may be provided to the user with the photoprotective composition, for example in the same package,

or adhesively bonded on top with a repositionable adhesive, as illustrated in figure 3. As a variant (not shown) the chart is fastened, especially adhesively bonded, to the cap, and not to the body, of the container containing the photoprotective composition. The chart may also be provided in the same package as a digital medium on which a program is stored, allowing the device to execute the algorithms required to implement the invention.

5 **[0093]** Figure 3a shows a variant in which the chart 30 is provided to the user with a casing 22 for protecting the device, the latter being a smartphone or a tablet computer, for example. The chart 30 and the casing 22 may, as illustrated, be provided to the user in the same packaging 50. The chart 30 may be configured so as to be able to be fastened to the casing 22, for example by adhesive bonding, and to be able to be separated therefrom at the moment of use.

10 **[0094]** A plurality of self-adhesive charts 30 may be provided to the user, these charts being bonded to the same anti-adhesive supporting sheet 34, as illustrated in figure 4.

**[0095]** Thus, the user may use a new chart when the preceding chart is no longer sticky enough to adhere to the skin for enough time to make the measurement.

**[0096]** If required, the anti-adhesive supporting sheet 34 takes the form of a strip, as illustrated in figure 5, and may be contained on a reel.

15 **[0097]** The chart may comprise an identifier 36 or a hyperlink or a barcode allowing the device to recognize the chart or the user to download an application allowing the chart to be used. As a variant, this identifier, link or barcode is present in a package in which the chart is contained.

**[0098]** Recognition of the chart by the device may be useful when there are a number of charts on the market with different properties.

20 **[0099]** In this case, since the device recognizes the chart, it may access the relevant color data.

**[0100]** As a variant, the chart comprises a code that directly informs the device of the color coordinates of the various regions of the chart. This is, for example, a Data Matrix 2D barcode encoding the color coordinates, for example the color coordinates measured after printing of the chart.

25 **[0101]** As a variant, the chart may comprise a security element. In this case, the device may be configured to recognise the signal produced by said security element present in the chart and thus permit, when said signal is detected, the method according to the invention to be implemented. The device may, of course, be configured to prevent the method according to the invention from being implemented when said signal is not detected. The presence of a security element may also allow a user to check the authenticity of the chart, for example by looking for a visible optical effect produced by the security element present in the chart.

30 **[0102]** Among the security elements that may be incorporated in the chart, certain security elements can be detected with the naked eye, under sunlight or artificial light, without any particular apparatus being used. These security elements for example comprise colored fibers or flakes, or partially or completely metallized or printed threads. These security elements are what are called level one security elements.

35 **[0103]** Other types of additional security elements can only be detected using a relatively simple device such as an ultraviolet (UV) or infrared (IR) lamp. These security elements for example comprise fibers, flakes, strips, threads or particles. These security elements may be visible or invisible to the naked eye, being, for example, luminescent under illumination from a Wood's lamp emitting at a wavelength of 365 nm. These security elements are what are called level two security elements.

40 **[0104]** The detection of other types of security element requires the use of a more sophisticated detection device. These security elements are for example capable of generating a specific signal when they are subjected, simultaneously or otherwise, to one or more external excitation sources. The automatic detection of the signal allows the chart to be authenticated, if required. These security elements for example comprise tracers taking the form of active materials, particles or fibers capable of generating a specific signal when these tracers are subjected to optronic, electric, magnetic, or electromagnetic excitation. These security elements are what are called level three security elements.

45 **[0105]** Reactive agents may also be incorporated in the chart, these are for example reactive chemical or biochemical agents allowing authentication and/or identification and/or for preventing counterfeiting, the agents being able to react, respectively, with, in particular, at least one agent allowing authentication and/or identification and/or for preventing counterfeiting.

50 **[0106]** The one or more security elements present in the chart may be level one, level two or level three security elements.

**[0107]** Although it is preferable for the chart to be independent of the device, the chart, in variant embodiments that are not illustrated, may nevertheless be connected to the device, either by being removably attached to a casing of the latter, or to a retractable element that is securely fastened to the jacket of the device, which element is extracted to carry out the measurement and then replaced afterwards.

55 **[0108]** The chart may be coated with a mat or gloss varnish that protects from UV.

Device

[0109] The device 20 is preferably a smartphone.

[0110] The device is thus preferably equipped with a wireless telephony function allowing it to download a software package that is then run on the device, or to download data needed by the software package to implement the method according to the invention.

[0111] The device may also comprise a housing for receiving a memory card, which card may contain the program to be executed. This card may have been supplied with the chart, as indicated above.

[0112] The device comprises a high- or low-resolution color camera 21, for example with more than 1 Mpixels, and may optionally have an autofocus and/or an optical zoom function.

[0113] The device also has a color screen and a keyboard, the screen possibly being a touchscreen.

[0114] The device is for example an iPhone, sold by Apple Inc, or a mobile telephone using an Android or Windows operating system or another operating system.

[0115] The program run when the invention is implemented may have been preinstalled on the device or may be downloaded subsequent to its purchase by the user.

[0116] The program may be downloaded by connecting to a server or by introducing a data medium, such as a memory card, for example a micro SD card, containing the program to be executed, into the device. The download may, if required, be carried out at a point of sale by way of a short-range connection, for example a Bluetooth or Wifi connection.

[0117] When the program must be downloaded by the user, it is possible for the download to take place after the user has answered a questionnaire, for example concerning the type of device used, their skin type, their age, their gender, and their habits in terms of use of cosmetic products or outdoor activities.

[0118] The program transferred to the device may depend on the responses to this questionnaire and especially on the make of the device that will receive the program. This is advantageous because it allows the technical features of the camera of the device to be taken into account during the acquisition, and the instructions given to the user to be matched to the nature of the device and to its capabilities.

[0119] If required, the aforementioned questionnaire is displayed when the program run by the device is initiated, as illustrated in figure 8A.

[0120] The device may also be provided with a geolocation function, for example a GPS chip. As a variant, the geolocation function is ensured by the telephone network. The location and the weather forecast may be displayed by the device in the context of execution of the program, as illustrated in figure 8D.

[0121] The device does not need to comprise a UV radiation sensor. However, preferably, the device may automatically access a weather-forecast server that provides it with information on the weather to come in the location where the user will be, and optionally on the strength of UV radiation.

[0122] In an exemplary embodiment, the device may be connected to a sensor allowing the strength of ambient UV radiation to be measured. In this case, the sensor may be present on the device or even on a casing of the latter. It may even be envisioned for the sensor to be carried by the user themselves, for example on their wrist.

[0123] The device need not be a smartphone, it may for example be a tablet computer, for example an iPad2 or another tablet PC, a smart digital camera, a portable computer equipped with a webcam, or a portable digital music player, for example an iPod. More generally, any device comprising a camera and able to run a software package may be used.

[0124] Preferably, the device fits in the hand, which makes it easier to handle during acquisition of the images of the chart placed on the skin.

Measuring process

[0125] Various steps of an example of a measuring process are illustrated in figure 6.

[0126] To obtain the measurements, a region of skin free from blemishes, i.e free from beauty spots, scars, wounds, hair, and protruding blood vessels, is selected.

[0127] According to one variant of the invention, the color of the skin is measured in at least one region that is not normally exposed to the sun, in order to obtain a reference skin color, which corresponds to step 41 in figure 6. Additionally, the color of the skin may be measured in a region that has already been exposed. The user may be asked by the device to choose, as illustrated in figure 8B, what type of measurement they would like to carry out, for example measurement of unexposed skin, i.e. "initial ITA°" or measurement of previously exposed skin, i.e. "current ITA°".

[0128] The normally unexposed region is typically a region that is not exposed because clothing is worn over it, or because of its orientation. It may for example be the upper part of the arm, the stomach, the breasts or buttocks.

[0129] To carry out the acquisition, the user places the chart 30 on this region and takes a photograph of the chart or films it. It may be advantageous to take a number of photographs or to film said region in step a).

[0130] The user preferably ensures that the image is clear and includes the colors and gray regions of the chart. If required, the device automatically performs this check, and sounds an alarm if the image is unsuitable for the measure-

ment.

**[0131]** The program run by the device determines parameters for color conversion tables allowing, for example, RGB signals delivered by the camera for the various regions of the chart to be converted into the absolute color coordinates in the CIE  $L^*a^*b^*$  space known by the device for these regions.

**[0132]** If required, in the case where a number of charts are available on the market, it may be necessary to communicate a chart identifier to the device beforehand, so that the device knows what colors the various regions correspond to. For this purpose, the chart may contain an identifier 36, which is deciphered by the device.

**[0133]** Once the color acquisition units of the device 20 have been calibrated, the color of the skin in the image, for example in a window 31 in the chart the outline of which window can be easily detected in the image, can be measured.

**[0134]** For example, an average color is determined over all of the skin pixels observed through the window 31. This allows the color coordinates  $L^*$ ,  $a^*$  and  $b^*$  to be found for the skin and, in step 42, the  $ITA^\circ$  angle of the unexposed skin to be calculated by applying the formula given above, established by A. Chardon.

**[0135]** Knowing the  $ITA^\circ$  angle of the unexposed skin, it is possible to determine the skin type, as illustrated in figure 7, and optionally to indicate it to the user. For example, the device displays "very light skin" for an angle larger than  $55^\circ$ , "light skin" for  $41^\circ < ITA^\circ < 55^\circ$ , "intermediate skin" for  $28^\circ < ITA^\circ < 41^\circ$ , "olive-colored skin" for  $10^\circ < ITA^\circ < 28^\circ$ , "brown skin" for  $-30^\circ < ITA^\circ < 10^\circ$ , or "black skin" for  $ITA^\circ < -30^\circ$ , and may also display the value of the  $ITA^\circ$  angle.

**[0136]** Moreover, since tanning pathways  $L^*$  (lightness) are known as a function of  $b^*$  (position on the blue/yellow axis), it is possible to determine the change in  $L^*$  as a function of  $b^*$  during the pigmentation process for the skin in question, and to deliver a corresponding indication to the user.

**[0137]** Tanning pathways, two examples of which, denoted by the references  $CB_1$  and  $CB_2$ , are shown in figure 7 for two different individuals having substantially the same initial  $ITA^\circ$  angle, are known from studies among reference populations, as discussed in the article by A. Chardon mentioned above. In figure 7, the path taken before and/or after each day of tanning, D1 to D9, has been shown on each tanning path.

**[0138]** In a preferred variant, the device may be configured to measure and memorize, with a view to subsequent use, the actual tanning pathway of the user. This measurement may be carried out over a number of days spent tanning, for example 5 to 15 days spent tanning. During each day spent tanning, the user may apply a photoprotective composition of a known photoprotective power and proceed, at the end of the day, with an acquisition of the color value of their skin. Acquiring this color value over a number of days spent tanning will allow the actual tanning pathway of the user to be determined.

**[0139]** Knowledge and use, in the context of methods according to the invention, of the actual tanning pathway of the user may advantageously allow the indication delivered in step b) to be made more accurate.

**[0140]** In order to determine the change in the  $ITA^\circ$  angle as a function of exposure to the sun, a relationship giving the  $ITA^\circ$  angle as a function of the biologically effective dose (BED) is used, which relationship is determined by experiments on reference populations, as illustrated in figure 9 after the article by S. Del Bino et al., Relationship between skin response to ultraviolet exposure and skin color type, Pigment Cell Res.. Journal compilation 2006 Blackwell Munksgaard.

**[0141]** The received dose may be calculated based on UV radiation at a given location for given weather conditions and for a given activity. Knowledge of the activity may lead to the expected dose being reduced or increased; for example, if the activity involves lying in the sun without moving, the dose is maximized. If the activity involves playing a sport, which will presumably involve continuous changes in orientation relative to the sun, the dose will be lower than in the case of inactivity. Knowing the dose that the individual is liable to receive, it is possible to determine the corresponding change in the  $ITA^\circ$  angle that would be observed if no photoprotection were used.

**[0142]** The measurement may be repeated in step 43 on a region of skin that has already been exposed to the sun, in order to determine, in step 44, the  $ITA^\circ$  angle of the region considered and discover how far the pigmentation process has progressed.

**[0143]** The indication may be delivered to the user by displaying, on the screen, both the measured skin color and one or more skin colors obtainable via the pigmentation process, the latter colors being calculated using knowledge of the tanning pathway applicable to the skin for which the color has been measured.

**[0144]** The color of the screen is preferably calibrated, as explained above.

**[0145]** However, even if the screen color has not been calibrated, simultaneously displaying the one or more colors obtainable via the pigmentation process, as illustrated in figure 8F, nevertheless provides the user with information allowing them to see, by comparison, the possible changes in skin color available to them, despite the color drift of the screen.

**[0146]** In one variant, the device does not display this color, or in addition to displaying the color delivers information relating to an atlas of skin colors, thereby allowing the user to find, in the atlas, their skin color and those obtainable via the subsequent pigmentation process. Such an atlas, which is advantageously printed in a way that eliminates metamorphism, may be present at a point of sale or be provided to the user with a cosmetic composition or with the chart or the program to be run by the device.

**[0147]** If required, the chart may contain one or more flesh colors, identified by identifiers, which correspond to colors to which the device may refer in order to allow the user to identify the color with more precision than is possible using the screen.

5 **[0148]** The method may comprise, as illustrated in figure 8F, a step consisting in asking the user to select that color, obtainable via the pigmentation process, which they would like to obtain.

**[0149]** For example, the device displays on the screen, as illustrated in this figure, colors on the tanning pathway of the user, and allows the user to select one color therefrom as the result to be obtained from the pigmentation process.

10 **[0150]** The device may furthermore ask the user for the length of time they will be staying at a given location, for example a holiday destination, and, based on this information, determine whether the pigmentation result selected by the user is feasible, without risking of erythema, in the amount of time allowed.

**[0151]** The device may determine the photoprotection to be applied based on knowledge of the incidence of the dose received on the color of the skin and on the appearance of solar erythema.

**[0152]** The program may also allow the user to measure the level of pigmentation acquired in any region of the body.

15 **[0153]** To do this, the user carries out an acquisition, using the chart, of the region for which they wish to know the acquired pigmentation level, for example the forehead. This assumes that the user has carried out an acquisition beforehand on an unexposed region, as detailed above.

20 **[0154]** Using the chart, an acquisition carried out on any region allows the ITA° angle to be calculated for this region and, assuming the ITA° angle of the unexposed region is known, allows, based on data known for the reference population, in this instance the reference population having the same original ITA°, the maximum ITA° angle that will be obtained at the end of the pigmentation process to be determined.

**[0155]** It is then possible to indicate to the user where they are on their tanning pathway, as illustrated in figure 8C, for example by showing extreme ITA° angles and the current ITA° angle.

25 **[0156]** This information may be delivered in various forms. For example, the device may deliver a message informing the user that their pigmentation level will not change much in certain regions of their body or face, which may encourage the user to avoid exposing them to the sun or to apply more protection to them.

**[0157]** The color measurement carried out on exposed regions may also be used, especially by virtue of the a\* component on the red/green axis, to detect the appearance of potential solar erythema and to inform the user of the benefit of avoiding further exposure of such-and-such a region of the body or face to the sun until the inflammation reaction has disappeared.

30 **[0158]** The device may determine the presence or absence of erythema because the initial ITA° angle and a reference a\* coordinate, measured by the device before exposure to the sun, are known. The device can compare the new measurement with the previously measured value and/or with the pigmentation that should have been acquired in the absence of erythema.

35 **[0159]** A change in a\* smaller than a given threshold between two measurements may confirm that the individual has not developed an erythema and has correctly followed protection advice. In the case where erythema is detected, a warning message cautions the user to avoid further exposure to the sun.

**[0160]** If required, the device may, in the case where erythema is detected, take this into account when determining the photoprotective composition to be applied subsequently, for example by recommending the maximum photoprotection.

40 **[0161]** The device may be set up to suggest a makeup or self-tanning product that gives the user a skin color, which would have been obtainable via the pigmentation process, selected by the user, as illustrated in figure 8G. In this figure, the device displays two buttons allowing the user to select a recommended tanning product or a recommended makeup product.

45 **[0162]** The program may have, stored in memory, references to a number of products that may be applied to obtain such-and-such a skin color. The device may choose the product to be suggested to the user, if required, by way of a look-up table, stored in the memory of the device or accessible to the latter, comprising two data types, namely the color to be obtained and the current color, and for each of these pairs, one or more references to products listed as being likely to be suitable.

50 **[0163]** During the acquisition, or after the latter, the image may be analyzed to determine whether there are regions of very non-uniform color on the skin, and the device may take such regions into account in order to avoid using pixels attributed to color heterogeneities such as pimples, beauty spots, hairs or protruding blood vessels, when calculating the color of the skin. The device may also be set up to signal that an acquisition must be carried out in another zone, because of the presence of color inhomogeneities.

55 Photoprotection

**[0164]** The device may provide the user with information regarding the use of a photoprotective composition to be applied, with the aim of obtaining a skin color selected from among colors obtainable naturally via the pigmentation

process.

**[0165]** The device may especially determine the SPF factor to be used depending on the pigmentation results that it is desired to obtain and on environmental factors such as UV radiation strength, activity undertaken, and the weather forecast.

**[0166]** The device may for example display a questionnaire allowing the user to indicate what activities they intend to undertake at various times of the day, as illustrated in figure 8E.

**[0167]** For example, a calendar is displayed by the device in which the weather forecast for various times of the day is displayed, and the user may indicate, for each of these moments, whether they will be in or out of doors, in the sun or under shade, in a highly reflective environment or not, active or inactive. This information may also be imported by the device from an electronic calendar where it has already been entered.

**[0168]** Next, the device calculates the maximum exposure liable to be received each day and generates a recommendation, for example by generating, on the calendar or on the welcome screen of the device, an icon indicating the solar protection factor to be used at each moment during the day, for example. In the example in figure 8G, the device indicates, for each of the days to come, the protection factor to be applied.

**[0169]** If required, the program triggers the emission of an audio, visual, or tactile signal at certain moments, to remind the user, for example, of the benefit of reapplying the photoprotective composition to certain regions.

**[0170]** At the end of the day, for example before the user goes to bed, the device may be used to carry out a new measurement in order to confirm the absence of erythema and, in the case where erythema is detected, make a recommendation to the user regarding the days to come, for example advising them not to expose the region concerned or to change to a higher protection factor. The device may also advise the application of a suitable soothing product, once erythema has been detected.

**[0171]** As indicated above, the device may be set up, as illustrated in figure 10, to communicate with what is called a smart container/applicator 100, for example by virtue of a wireless link between the device and said container/applicator.

**[0172]** For example, this container/applicator has two compartments containing products with different protection factors and a mixer allowing the contents thereof to be mixed in chosen proportions, in order to obtain the desired protection factor, such as described, for example, in application US 2011/0247718 A1.

**[0173]** In this case, the device may automatically deliver set point data to the container/applicator allowing a composition with a suitable SPF to be obtained.

**[0174]** In a variant, the photoprotective composition is contained in a bottle equipped with an identifier, for example a bar code, that can be recognized by the device, using the camera.

**[0175]** The device may then identify the photoprotective composition which the user has at their disposal and, knowing this, give advice regarding its use, for example recommending an application frequency or signaling that the factor of the composition used will only allow the user to stay in the sun for a certain amount of time before they risk suffering from erythema.

**[0176]** The device may signal to the user, if required, that they may expose themselves to the sun or that it is time for them to cover themselves or get into the shade. The user may signal the moment when their exposure starts, in order to allow the device to then generate an alarm, by calculating the length of the exposure and the dose received, when there is a risk of erythema.

**[0177]** The program run by the device is advantageously a multi-user program, thereby allowing a number of people to identify themselves and use the device one after the other while retaining the benefit of previous sessions.

**[0178]** The invention is not limited to the examples that have just been described.

**[0179]** For example, the acquisition of the initial ITA° angle of unexposed skin may be carried out at a point of sale using a dedicated device. Next, the individual may use their smart phone to measure the pigmentation level obtained, without once more having to carry out an acquisition in an unexposed region, by downloading an application from a server to which the data acquired at the point of sale will have been communicated.

**[0180]** As yet another variant, the user employs a computer equipped with a webcam, and a chart that they have obtained, for example, from their travel agent or hotel. The result of the acquisition is sent to a remote site that generates advice regarding photoprotection, for example by indicating the factor that each member of the family should use and the pigmentation that each member is liable to obtain, depending on a given activity program, for example proposed by the agent or hotel.

**[0181]** The tanning pathway may be determined in a color space other than the CIE L\*a\*b\* space.

**[0182]** Skin type may be determined by calculating a quantity other than the ITA° angle.

**[0183]** The expression "comprising a" should be understood to be synonymous with "comprising at least one".

## Claims

1. A cosmetic method in which:

- 5 a) a color is acquired from a region of the body of an individual, by using a device (20) equipped with a color camera (21) and by placing a color reference chart (30) in the field of said camera during the acquisition and acquiring an image of the chart, wherein the color reference chart and a region of skin adjoining this chart are recognized by the device and acquisition units of the device are colorimetrically calibrated via knowledge of absolute color coordinates of the chart; and
- 10 b) delivering, using the device (20), and the color acquired by the device in a) and knowledge of the tanning pathways of various skin phototypes, at least one indication concerning data representative of skin phototype and at least one indication selected from indications concerning
- at least one skin color obtainable by the individual via the pigmentation or depigmentation process,
  - photoprotection to be applied, and
  - application or administration of a product intended to temporarily modify the color of the skin, the product being a pro-pigmenting, depigmenting or anti-pigmenting product.
- 15 2. The method as claimed in claim 1, in which step a) is used to measure the skin color of a region that is not exposed to the sun or to an exogenous or endogenous stimulus inducing pigmentation or depigmentation, preferably the upper part of the forearm, the stomach, the breasts, or the buttocks, and most preferably, in which the measurement carried out on the unexposed region is used to determine skin type, and preferably the information regarding skin type is delivered by the device.
- 20 3. The method as claimed in claim 2, in which:
- 25 c) a second acquisition is carried out on another skin region, liable to have already been exposed to the sun, using the device (20) and preferably placing the color reference chart (30) in the field of the camera, in which information is automatically delivered with said device, the information concerning the pigmentation and/or photoprotection level already obtained by this other region, based on the color acquisitions carried out in a) and c) and on knowledge of the tanning pathway.
- 30 4. The method as claimed in any one of the preceding claims, in which the user is asked to enter, into the device, information concerning the desired pigmentation level and/or skin color to be acquired and, at least on the basis of the information entered into the device, an indication is delivered on the photoprotection to be applied.
- 35 5. The method as claimed in the preceding claim, in which the user is asked to enter information on the length of time they will be staying in a given location, and in which the indication regarding photoprotection is delivered depending on this information regarding length of stay.
- 40 6. The method as claimed in any one of the preceding claims, in which the user is asked to enter information on the desired skin color, and in which the device delivers information, depending at least on the acquisition carried out in a) or in c), regarding the way to obtain it via the pigmentation process or via application or administration of a product intended to temporarily modify the color of the skin.
- 45 7. The method as claimed in any one of the preceding claims, in which the color reference chart (30) contains windows, and in which the color acquisition is carried out through at least one window (31) in the chart.
8. The method as claimed in any one of the preceding claims, in which the color reference chart (30) comprises at least three different gray levels ( $G_1, \dots, G_n$ ) and at least three different colors ( $C_1, \dots, C_m$ ).
- 50 9. The method as claimed in any one of the preceding claims, the device (20) being portable and comprising a screen, the device preferably being equipped with a wireless telephone and/or computer connection.
- 55 10. The method as claimed in any one of claims 1 to 9, in which an indication is delivered by the device, the indication concerning one or more products and/or combinations of products or instruments intended to temporarily modify skin color, to be applied or administered to obtain a skin color corresponding to a real skin color of the user that may be obtained via the pigmentation process, said indication being determined via knowledge of the skin color, especially the unexposed skin color, of the user and of their tanning pathway.
11. The method as claimed in any one of the preceding claims, in which a program is downloaded before the color acquisition is initiated, this program allowing the device to carry out the color acquisition and to provide the one or more indications concerning the skin type and/or concerning the one or more skin colors that are obtainable via the

pigmentation or depigmentation process and/or concerning application or administration of the product intended to temporarily modify the color of the skin and/or concerning the photoprotective composition to be applied.

5 12. The method as claimed in any one of the preceding claims, in which a quantity representative of a\* is measured before and after exposure to the sun, and, depending on the difference, the presence or absence of erythema is determined, and preferably, if erythema is detected, the device delivers a warning message and/or takes the erythema into account when recommending the photoprotective composition to apply.

10 13. The method as claimed in any one of the preceding claims, in which calibration of the acquisition units of the device comprising determining parameters for color conversion tables configured for converting RGB signals delivered by the camera for the various regions of the chart into the absolute color coordinates in the CIE L\*a\*b\* space known by the device for these regions.

15 14. A system for implementing the method according to any one of claims 1 to 13, comprising:

- a portable device (20) equipped with a color camera, preferably a smart phone or a tablet computer; and
- a color reference chart (30) the color coordinates of which are known by the device,

20 the device being configured for delivering on the basis of the color acquired by the device and knowledge of the tanning pathways of various skin phototypes, at least one indication concerning data representative of skin phototype and at least one indication selected from indications concerning:

- at least one skin color obtainable by the individual via the pigmentation or depigmentation process,
- photoprotection to be applied, and
- 25 - application or administration of a product intended to temporarily modify the color of the skin, the product being a pro-pigmenting, depigmenting or anti-pigmenting product.

30 15. A computer software package for implementing the method as claimed in any one of claims 1 to 13, comprising data allowing, when loaded, preferably by way of a connection to a remote server, into a device (20), such as a smart phone or a tablet computer, equipped with a camera:

- the acquisition of the image of a color reference chart (30) placed on the skin to be controlled;
- the color reference chart and a region of skin adjoining this chart to be recognized in the image;
- acquisition units of the device to be colorimetrically calibrated via knowledge of the absolute color coordinates of the chart; and
- 35 - an indication concerning data representative of skin phototype and an indication selected from indications concerning
  - 40 ■ at least one individual skin color obtainable via the pigmentation or depigmentation process,
  - application or administration of a product intended to temporarily modify the color of the skin, the product being a pro-pigmenting, depigmenting or anti-pigmenting product, and
  - a photoprotection to be applied, to be generated, based on knowledge of the skin color measured in the image.

45 **Patentansprüche**

1. Kosmetisches Verfahren, in dem:

- 50 a) eine Farbe von einem Bereich des Körpers eines Individuums durch das Verwenden einer Vorrichtung (20), die mit einer Farbkamera (21) ausgestattet ist, und durch das Platzieren einer Farbreferenzkarte (30) in das Feld der Kamera während der Erfassung und des Erfassens eines Bildes der Karte erfasst wird, wobei die Farbreferenzkarte und ein an diese Karte angrenzender Hautbereich von der Vorrichtung erkannt werden und Erfassungseinheiten der Vorrichtung über die Kenntnis der absoluten Farbkoordinaten der Karte kolorimetrisch kalibriert werden; und
- 55 b) Abgeben unter Verwendung der Vorrichtung (20) und der von der Vorrichtung in a) erfassten Farbe und der Kenntnis der Bräunungswege verschiedener Hautfototypen wenigstens einer Angabe über für die Hautphototypie repräsentative Daten und wenigstens einer Angabe, ausgewählt aus Angaben über

## EP 2 793 643 B1

- wenigstens eine Hautfarbe, die das Individuum durch den Pigmentierungs- oder Depigmentierungsvorgang erhalten kann,  
- eine anzuwendende Photoprotektion, und  
- eine Anwendung oder eine Verabreichung eines Produkts, das die Hautfarbe vorübergehend verändern soll, wobei das Produkt ein Pro-, Depigment- oder Antipigmentierungsprodukt ist.
- 5
2. Verfahren nach Anspruch 1, in dem Schritt a) verwendet wird, um die Hautfarbe eines Bereichs zu messen, der nicht der Sonne oder einem exogenen oder endogenen Stimulus ausgesetzt wird, der eine Pigmentierung oder Depigmentierung hervorruft, vorzugsweise der obere Teil des Unterarms, der Bauch, die Brüste oder das Gesäß, und am stärksten bevorzugt, in dem die Messung, die an dem nicht ausgesetzten Bereich ausgeführt wird, verwendet wird, um den Hauttyp zu bestimmen, und vorzugsweise die Informationen bezüglich des Hauttyps durch die Vorrichtung geliefert werden.
- 10
3. Verfahren nach Anspruch 2, in dem:
- 15 c) eine zweite Erfassung an einem anderen Hautbereich, der möglicherweise bereits der Sonne ausgesetzt wurde, unter Verwendung der Vorrichtung (20) und vorzugsweise durch das Platzieren der Farbreferenzkarte (30) in das Feld der Kamera durchgeführt wird, in der Informationen automatisch mit der Vorrichtung geliefert werden, wobei die Informationen den Pigmentierungs- und/oder Photoprotektionsgrad betreffen, der von diesem anderen Bereich bereits auf Grundlage der in a) und c) ausgeführten Farberfassungen und der Kenntnis des Bräunungsweges erhalten wurde.
- 20
4. Verfahren nach einem der vorhergehenden Ansprüche, in dem der Benutzer aufgefordert wird, Informationen über den gewünschten Pigmentierungsgrad und/oder die zu erfassende Hautfarbe in die Vorrichtung einzugeben, und wenigstens auf Grundlage der in die Vorrichtung eingegebenen Informationen eine Angabe auf die anzuwendende Photoprotektion geliefert wird.
- 25
5. Verfahren nach dem vorhergehenden Anspruch, in dem der Benutzer aufgefordert wird, Informationen über die Dauer, für die sie sich an einem bestimmten Ort aufhalten, einzugeben, und in dem die Angabe in Abhängigkeit von diesen Informationen über die Aufenthaltsdauer geliefert wird.
- 30
6. Verfahren nach einem der vorhergehenden Ansprüche, in dem der Benutzer aufgefordert wird, Informationen über die gewünschte Hautfarbe einzugeben, und in dem die Vorrichtung Informationen, die wenigstens von der in a) oder c) ausgeführten Erfassung abhängen, bezüglich der Art und Weise liefert, wie sie über den Pigmentierungsvorgang oder über die Anwendung oder die Verabreichung eines Produkts, das die Hautfarbe vorübergehend verändern soll, erhalten werden.
- 35
7. Verfahren nach einem der vorhergehenden Ansprüche, in dem die Farbreferenzkarte (30) Fenster enthält, und in dem die Farberfassung durch wenigstens ein Fenster (31) in der Karte ausgeführt wird.
- 40
8. Verfahren nach einem der vorhergehenden Ansprüche, in dem die Farbreferenzkarte (30) wenigstens drei verschiedene Graustufen ( $G_1, \dots, G_n$ ) und wenigstens drei verschiedene Farben ( $C_1, \dots, C_m$ ) umfasst.
- 45
9. Verfahren nach einem der vorhergehenden Ansprüche, wobei die Vorrichtung (20) tragbar ist und einen Bildschirm umfasst, wobei die Vorrichtung vorzugsweise mit einem drahtlosen Telefon und/oder einer Computerverbindung ausgestattet ist.
- 50
10. Verfahren nach einem der Ansprüche 1 bis 9, in dem durch die Vorrichtung eine Angabe geliefert wird, wobei die Angabe ein oder mehrere Produkte und/oder Kombinationen von Produkten oder Instrumente betrifft, die die Hautfarbe vorübergehend verändern sollen, die angewendet oder verabreicht werden sollen, um eine Hautfarbe zu erhalten, die einer echten Hautfarbe des Benutzers entspricht, die durch den Pigmentierungsvorgang erhalten werden kann, wobei die Angabe über die Kenntnis der Hautfarbe, insbesondere der nicht ausgesetzten Hautfarbe des Benutzers und seines Bräunungsweges bestimmt wird.
- 55
11. Verfahren nach einem der vorhergehenden Ansprüche, in dem ein Programm heruntergeladen wird, bevor die Farberfassung eingeleitet wird, wobei dieses Programm erlaubt, dass die Vorrichtung die Farberfassung ausführt und die eine oder die mehreren Angaben über den Hauttyp und/oder über den einen oder die mehreren Hauttypen, die über den Pigmentierungs- oder Depigmentierungsvorgang erhalten werden können, und/oder über die Anwendung oder Verabreichung des Produkts, das die Farbe der Haut vorübergehend ändern soll, und/oder über die

anzuwendende photoprotektive Zusammensetzung bereitstellt.

5 12. Verfahren nach einem der vorhergehenden Ansprüche, in dem eine für a\* repräsentative Menge vor und nach dem Aussetzen an die Sonne gemessen wird, und in Abhängigkeit von dem Unterschied das Vorhandensein oder Nichtvorhandensein von Erythemen bestimmt wird, und vorzugsweise, wenn ein Erythem nachgewiesen wird, die Vorrichtung eine Warnmeldung liefert und/oder das Erythem bei der Empfehlung der aufzutragenden photoprotektiven Zusammensetzung berücksichtigt.

10 13. Verfahren nach einem der vorhergehenden Ansprüche, in dem eine Kalibrierung von Erfassungseinheiten der Vorrichtung das Bestimmen von Parametern für Farbumwandlungstabellen umfasst, die für das Umwandeln von RGB-Signalen, die durch die Kamera für die verschiedenen Bereiche der Karte geliefert werden, in die absoluten Farbkordinaten in dem CIE L\*a\*b\*-Raum konfiguriert sind, der der Vorrichtung für diese Bereiche bekannt ist.

15 14. System zum Umsetzen des Verfahrens nach einem der Ansprüche 1 bis 13, umfassend:

- eine tragbare Vorrichtung (20), die mit einer Farbkamera, vorzugsweise ein Smartphone oder ein Tablet-Computer, ausgestattet ist; und
- eine Farbreferenzkarte (30), deren Farbkordinaten der Vorrichtung bekannt sind,

20 wobei die Vorrichtung konfiguriert ist, um auf Grundlage der von der Vorrichtung erfassten Farbe und der Kenntnis der Bräunungswege verschiedener Hautphototypen wenigstens eine Angabe über Daten, die für die Hautphototypie repräsentativ sind, und wenigstens eine Angabe liefert, ausgewählt aus Angaben über:

- wenigstens eine Hautfarbe, die das Individuum durch den Pigmentierungs- oder Depigmentierungsvorgang erhalten kann,
- eine anzuwendende Photoprotektion, und
- eine Anwendung oder eine Verabreichung eines Produkts, das die Hautfarbe vorübergehend verändern soll, wobei das Produkt ein Pro-, Depigment- oder Antipigmentierungsprodukt ist.

30 15. Computersoftware-Paket zum Umsetzen des Verfahrens nach einem der Ansprüche 1 bis 13, umfassend Daten, die, wenn sie vorzugsweise über eine Verbindung zu einem entfernten Server in die Vorrichtung (20), wie ein Smartphone oder einen Tablet-Computer, das/der mit einer Kamera ausgestattet ist, geladen werden, erlauben, dass:

- die Erfassung des Bildes einer Farbreferenzkarte (30), die auf die Haut platziert wird, gesteuert wird;
- die Farbreferenzkarte und ein dieser Karte angrenzender Hautbereich in dem Bild erkannt werden;
- Erfassungseinheiten der Vorrichtung über die Kenntnis über die absoluten Farbkordinaten der Karte kolorimetrisch kalibriert werden; und
- eine Angabe über Daten, die für die Hautphototypen repräsentativ sind, und eine Angabe, ausgewählt aus Angaben über:

- wenigstens eine Hautfarbe, die das Individuum durch den Pigmentierungs- oder Depigmentierungsvorgang erhalten kann,
- eine Anwendung oder eine Verabreichung eines Produkts, das die Hautfarbe vorübergehend verändern soll, wobei das Produkt ein Pro-, Depigment- oder Antipigmentierungsprodukt ist, und
- eine anzuwendende Photoprotektion, die auf Grundlage der Kenntnis der in dem Bild gemessenen Hautfarbe erzeugt werden soll.

## 50 Revendications

1. Procédé cosmétique dans lequel :

55 a) on acquiert une couleur à partir d'une région du corps d'un individu, en utilisant un dispositif (20) équipé d'une caméra couleur (21) et en plaçant une mire de calibration colorimétrique (30) dans le champ de ladite caméra lors de l'acquisition et en acquérant une image de la mire, dans lequel la mire de référence colorimétrique et une région de peau attenante à cette mire sont reconnues par le dispositif et on calibre colorimétriquement des unités d'acquisition du dispositif grâce à une connaissance de coordonnées de couleur absolues de la

## EP 2 793 643 B1

mire ; et

b) on délivre, au moyen du dispositif (20), et de la couleur acquise par le dispositif en a) et de la connaissance des chemins de bronzage de différents phototypes de peau, au moins une indication concernant des données représentatives du phototype de peau et au moins une indication choisie parmi les indications concernant

5

- au moins une couleur de peau pouvant être atteinte par l'individu grâce au processus de pigmentation ou dépigmentation,

- une photo-protection à appliquer, et

10

- l'application ou l'administration d'un produit destiné à modifier de manière temporaire la couleur de la peau, le produit étant un produit de pro-pigmentation, dépigmentation ou anti-pigmentation.

2. Procédé selon la revendication 1, dans lequel l'étape a) est utilisée pour mesurer la couleur de peau d'une région qui est non exposée au soleil ou à un stimulus exogène ou endogène induisant une pigmentation ou dépigmentation, de préférence, la partie supérieure de l'avant-bras, l'estomac, les seins ou les fesses, et de manière préférée entre toutes, dans lequel la mesure effectuée sur la région non exposée est utilisée pour déterminer le type de peau, et de préférence, l'information relative au type de peau est délivrée par le dispositif.

15

3. Procédé selon la revendication 2, dans lequel :

20

c) on effectue une seconde acquisition sur une autre région de peau, susceptible d'avoir déjà été exposée au soleil, au moyen du dispositif (20) et en plaçant de préférence la mire de calibration colorimétrique (30) dans le champ de la caméra, dans laquelle une information est automatiquement délivrée avec ledit dispositif, l'information concernant le niveau de pigmentation et/ou de photo-protection déjà atteint par cette autre région, sur la base des acquisitions colorimétriques effectuées en a) et en c) et de la connaissance du chemin de bronzage.

25

4. Procédé selon l'une quelconque des revendications précédentes, dans lequel on invite l'utilisateur à entrer dans le dispositif une information concernant le niveau souhaité de pigmentation et/ou de couleur de peau à acquérir et on délivre, au moins sur la base de l'information entrée dans le dispositif, une indication sur la photo-protection à appliquer.

30

5. Procédé selon la revendication précédente, dans lequel on invite l'utilisateur à entrer une information sur la durée de présence dans un lieu donné, et dans lequel l'indication relative à la photo-protection est délivrée en fonction de cette information relative à la durée de présence.

35

6. Procédé selon l'une quelconque des revendications précédentes, dans lequel on invite l'utilisateur à entrer une information sur la couleur de peau souhaitée et dans lequel on délivre avec le dispositif, en fonction au moins de l'acquisition effectuée en a) ou en c), une information sur la façon de l'obtenir, grâce au processus de pigmentation ou grâce à l'application ou l'administration d'un produit destiné à modifier de manière temporaire la couleur de la peau.

40

7. Procédé selon l'une quelconque des revendications précédentes, dans lequel la mire de calibration colorimétrique (30) est ajourée, et dans lequel l'acquisition colorimétrique s'effectue à travers au moins un ajour (31) de la mire.

8. Procédé selon l'une quelconque des revendications précédentes, dans lequel la mire de calibration colorimétrique (30) comporte au moins trois niveaux de gris différents ( $G_1, \dots, G_n$ ) et au moins trois couleurs différentes ( $C_1, \dots, C_m$ ).

45

9. Procédé selon l'une quelconque des revendications précédentes, le dispositif (20) étant portable et comportant un écran, le dispositif étant de préférence doté d'une liaison informatique et/ou téléphonique sans fil.

50

10. Procédé selon l'une quelconque des revendications 1 à 9, dans lequel on délivre une indication à l'aide du dispositif, l'indication concernant un ou plusieurs produits et/ou des combinaisons de produits ou instruments destinés à modifier de manière temporaire la couleur de la peau, à appliquer ou à administrer pour obtenir une couleur de peau correspondant à une couleur de peau réelle de l'utilisateur pouvant être atteinte grâce au processus de pigmentation, ladite indication étant déterminée par la connaissance de la couleur de peau, notamment de la couleur de peau non exposée, de l'utilisateur et de son chemin de bronzage.

55

11. Procédé selon l'une quelconque des revendications précédentes, dans lequel on télécharge un programme préalablement au lancement de l'acquisition colorimétrique, ce programme permettant au dispositif d'exécuter l'acquisition colorimétrique et de fournir l'indication ou les indications concernant le type de peau et/ou concernant la ou les couleurs de peau pouvant être atteintes grâce au processus de pigmentation ou de dépigmentation et/ou con-

## EP 2 793 643 B1

cernant l'application ou l'administration du produit destiné à modifier de manière temporaire la couleur de la peau et/ou concernant la composition photo-protectrice à appliquer.

- 5
12. Procédé selon l'une quelconque des revendications précédentes, dans lequel on mesure une quantité représentative de  $a^*$  avant et après exposition au soleil et en fonction de la différence, on détermine la présence ou l'absence d'un érythème, et de préférence, en cas de détection d'un érythème, le dispositif délivre un message d'alerte et/ou tient compte de l'érythème dans la préconisation de la composition de photo-protection à appliquer.
- 10
13. Procédé selon l'une quelconque des revendications précédentes, dans lequel la calibration des unités d'acquisition du dispositif comprend la détermination de paramètres de tables de conversion de couleurs configurées pour convertir des signaux RVB délivrés par la caméra pour les différentes régions de la mire en coordonnées colorimétriques absolues dans l'espace CIE  $L^*a^*b^*$  connu par le dispositif pour ces régions.
- 15
14. Système pour la mise en œuvre du procédé selon l'une quelconque des revendications 1 à 13, comportant :
- un dispositif portable (20) équipé d'une caméra couleur, de préférence un téléphone intelligent ou une tablette tactile ; et
  - une mire de calibration colorimétrique (30) dont les coordonnées colorimétriques sont connues du dispositif, le dispositif étant configuré pour délivrer sur la base de la couleur acquise par le dispositif et de la connaissance des chemins de bronzage de différents phototypes de peau, au moins une indication concernant des données représentatives du phototype de peau et au moins une indication choisie parmi les indications concernant :
- 20
- au moins une couleur de peau pouvant être atteinte par l'individu grâce au processus de pigmentation ou de dépigmentation,
  - une photo-protection à appliquer, et
  - l'application ou l'administration d'un produit destiné à modifier de manière temporaire la couleur de la peau, le produit étant un produit de pro-pigmentation, dépigmentation ou anti-pigmentation.
- 25
15. Produit programme d'ordinateur pour la mise en œuvre du procédé selon l'une quelconque des revendications 1 à 13, comportant des données permettant, lorsque chargées, de préférence par le biais d'une connexion à un serveur distant, dans un dispositif (20) tel qu'un téléphone intelligent ou une tablette tactile, équipé d'une caméra, de :
- 30
- contrôler l'acquisition de l'image d'une mire de calibration colorimétrique (30) placée sur la peau,
  - reconnaître sur l'image la mire de calibration colorimétrique et une région de peau attenante à cette mire,
  - calibrer colorimétriquement des unités d'acquisition du dispositif grâce à la connaissance des coordonnées colorimétriques absolues de la mire ; et
  - générer une indication concernant des données représentatives du phototype de peau et une indication choisie parmi les indications concernant
- 35
- au moins une couleur individuelle de peau pouvant être atteinte grâce au processus de pigmentation ou de dépigmentation,
  - l'application ou l'administration d'un produit destiné à modifier de manière temporaire la couleur de la peau, le produit étant un produit de pro-pigmentation, dépigmentation ou anti-pigmentation, et
  - une photo-protection à appliquer, sur la base de la connaissance de la couleur de peau mesurée sur l'image.
- 40
- 45
- 50
- 55

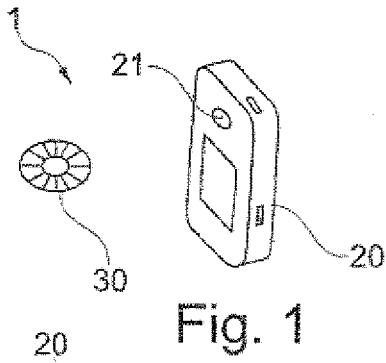

Fig. 1

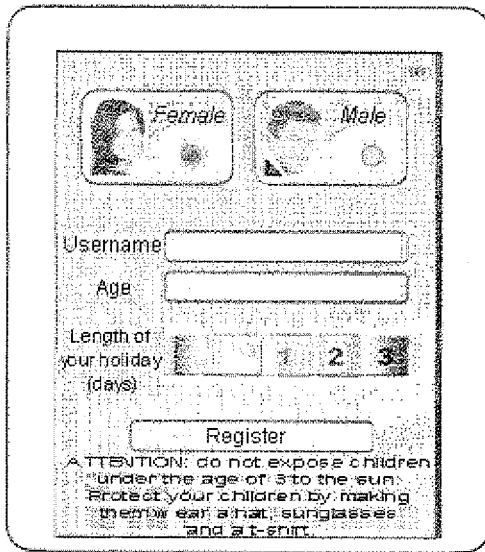

Fig. 8A

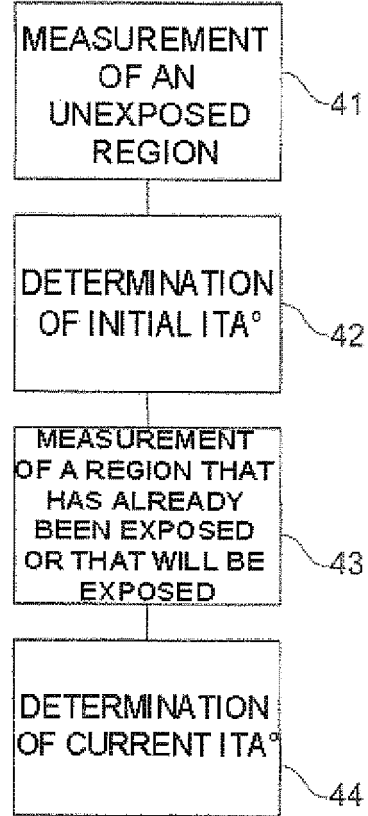

Fig. 6

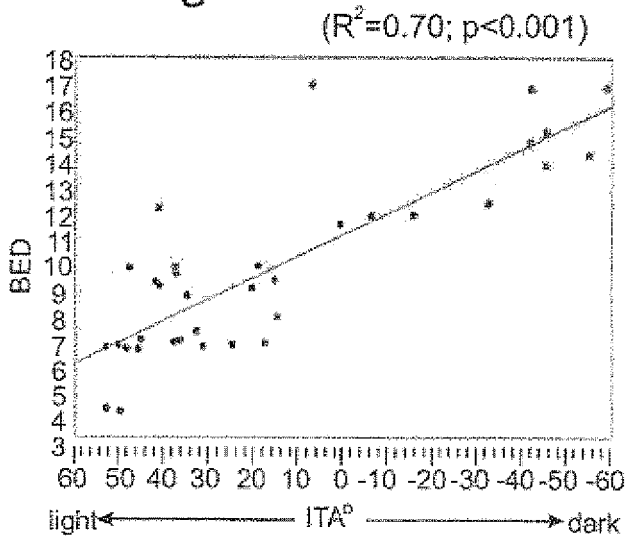

Fig. 9

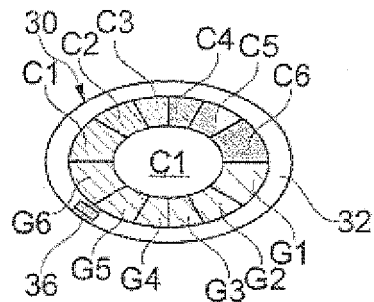

Fig. 2

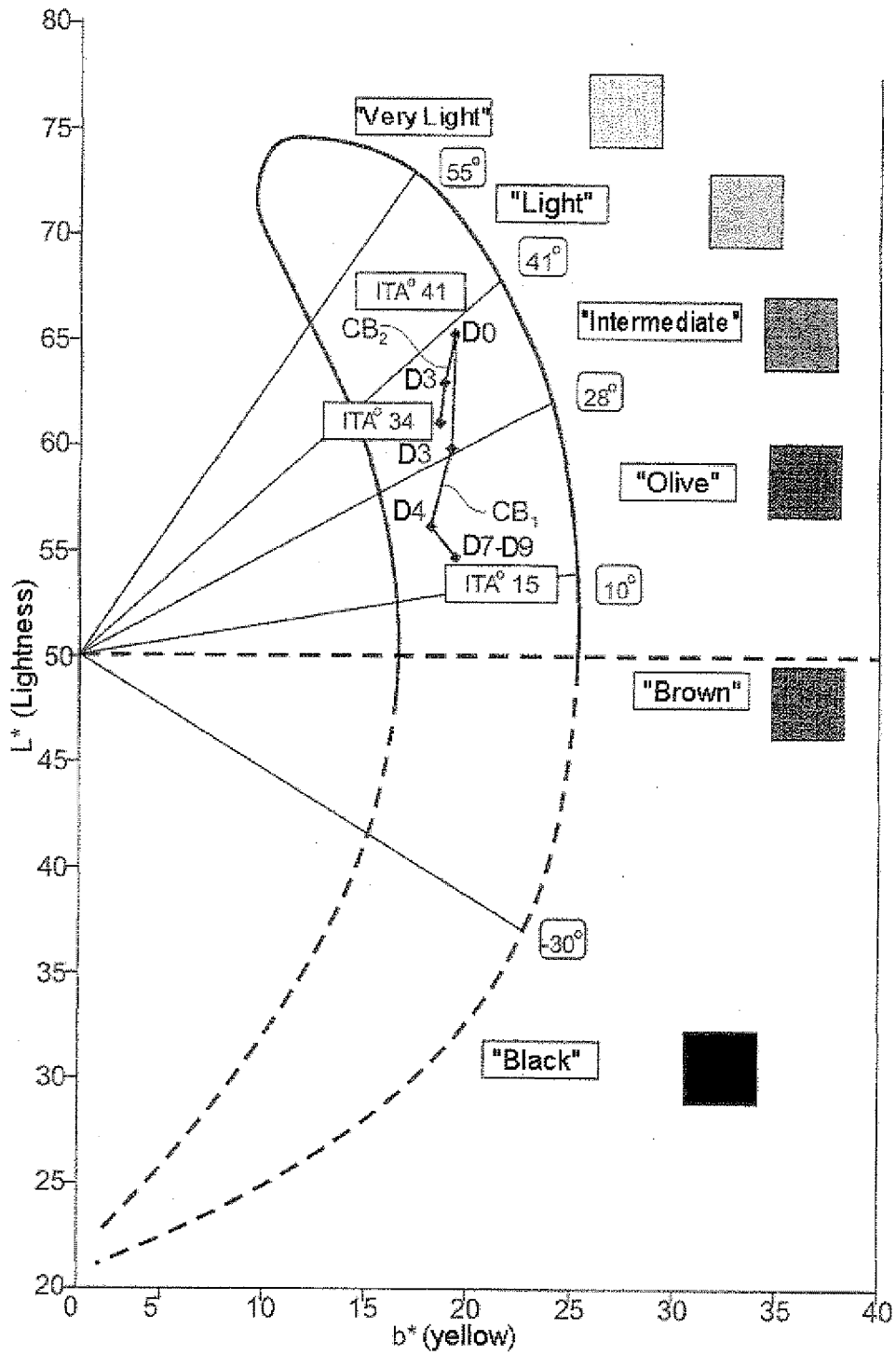

Fig. 7

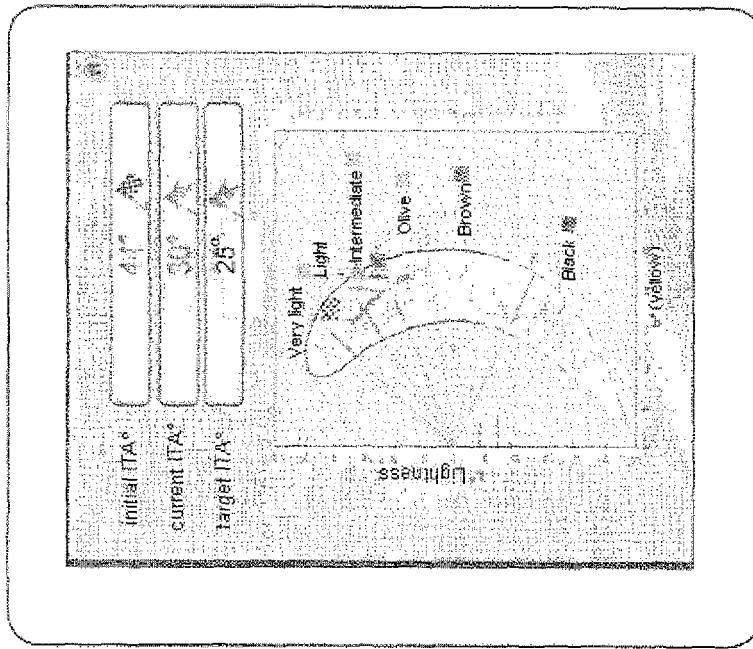

Fig. 8C

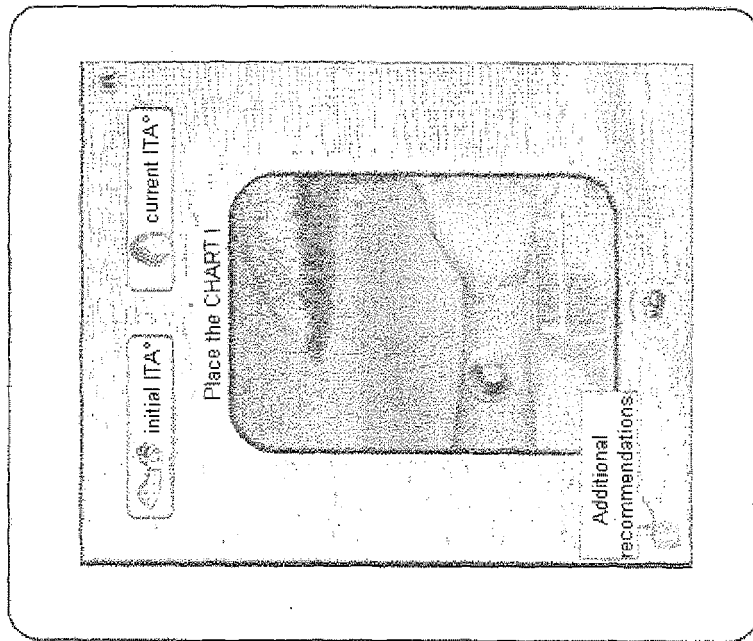

Fig. 8B

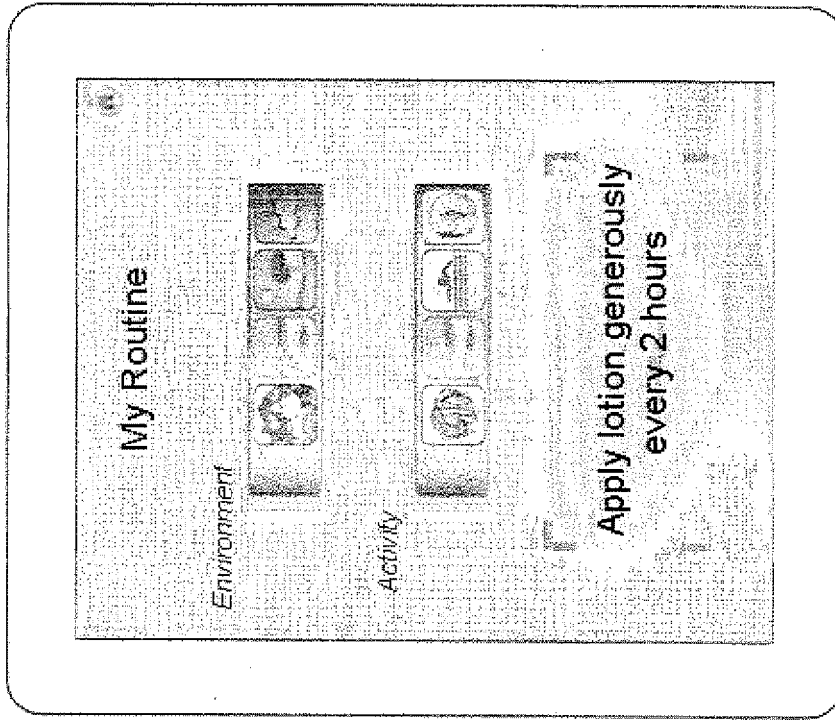

Fig. 8E

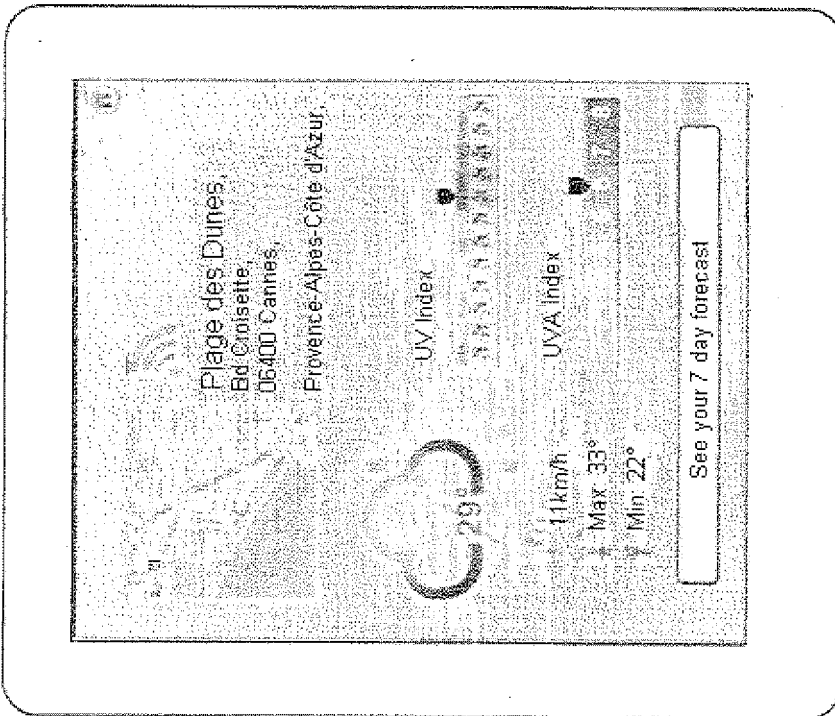

Fig. 8D

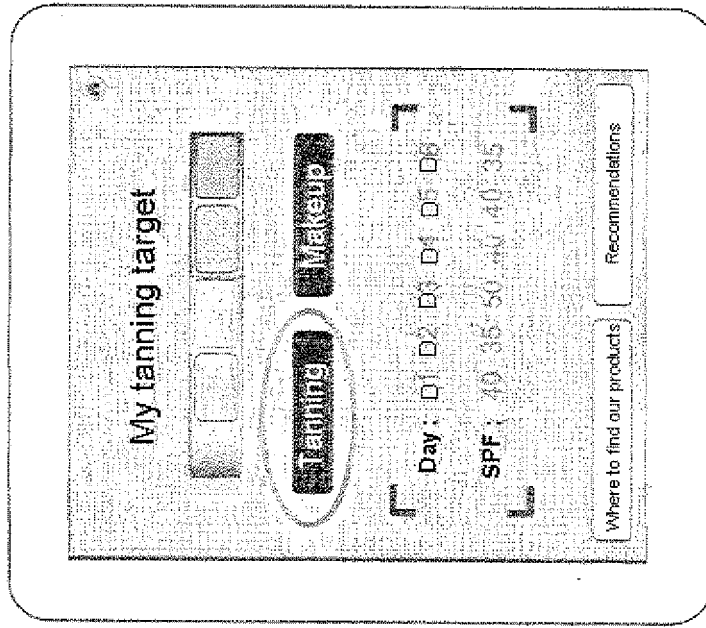

Fig. 8G

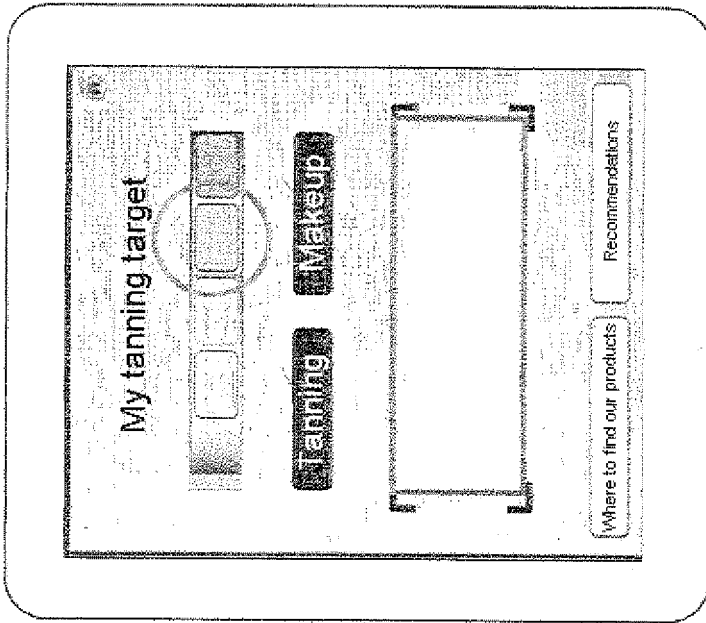
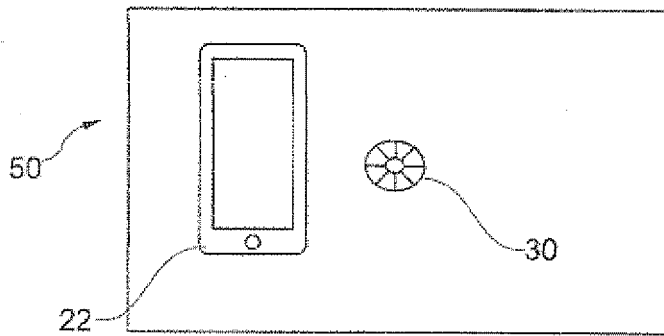
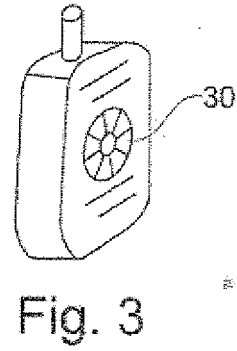
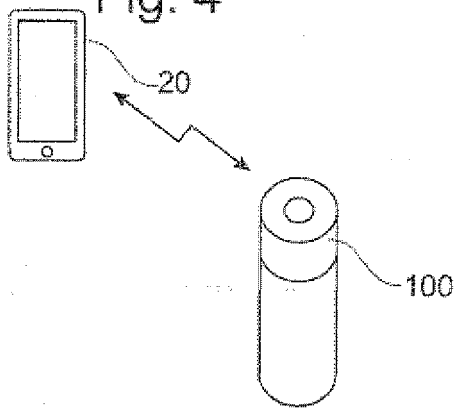
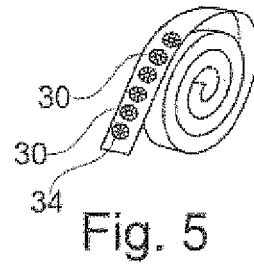
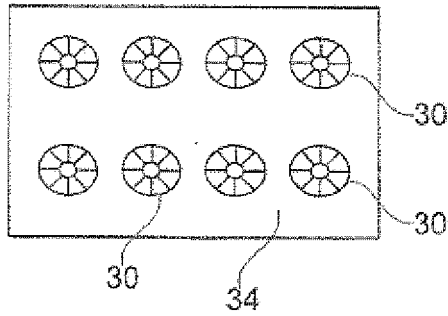

Fig. 8F



**REFERENCES CITED IN THE DESCRIPTION**

*This list of references cited by the applicant is for the reader's convenience only. It does not form part of the European patent document. Even though great care has been taken in compiling the references, errors or omissions cannot be excluded and the EPO disclaims all liability in this regard.*

**Patent documents cited in the description**

- FR 2937511 [0010]
- US 20110247718 A1 [0011] [0052] [0059] [0172]
- US 8044363 B [0013]
- US 20030067545 A1 [0016]
- US 20030064350 A1 [0017]
- US 20070058860 A [0018]
- DE 19612531 [0019]
- WO 2009013687 A [0020]
- WO 2008108760 A [0021]
- WO 2008038135 A [0022]

**Non-patent literature cited in the description**

- **A. CHARDON ; I. CRETOIS ; C. HOURSEAU.** Skin color typology and suntanning pathways. *International Journal of Cosmetic Science*, 1991, vol. 13, 191-208 [0003]
- Relationship between skin response to ultraviolet exposure and skin color type. **S. DEL BINO et al.** *Pigment Cell Res.. Journal compilation.* Blackwell Munksgaard, 2006 [0140]

专利名称(译)	提供美容建议的方法		
公开(公告)号	<a href="#">EP2793643A1</a>	公开(公告)日	2014-10-29
申请号	EP2012824713	申请日	2012-12-20
[标]申请(专利权)人(译)	欧莱雅		
申请(专利权)人(译)	欧莱雅		
当前申请(专利权)人(译)	欧莱雅		
[标]发明人	LUCET LEVANNIER KARINE CHRISTIAENS FRANCOIS		
发明人	LUCET- LEVANNIER, KARINE CHRISTIAENS, FRANÇOIS		
IPC分类号	A45D44/00 A61B5/103 A61B5/00		
CPC分类号	A45D44/005 A45D2044/007 A61B5/0077 A61B5/0082 A61B5/1034 A61B5/441		
代理机构(译)	NONY		
优先权	2011062435 2011-12-23 FR 61/592405 2012-01-30 US 61/645859 2012-05-11 US		
其他公开文献	EP2793643B1		
外部链接	<a href="#">Espacenet</a>		

#### 摘要(译)

一种美容方法，其中：a) 通过使用配备有彩色照相机的设备并通过在获取期间将彩色参考表放置在所述照相机的领域中，从个人的身体区域中获取颜色；和b) 使用该设备以及在a) 中获得的颜色，以及可选地了解各种肤色的晒黑途径，至少会发出一种有关皮肤类型的指示和/或至少会发出关于至少一种皮肤的指示。个体通过色素沉着或色素沉着过程可获得的颜色和/或至少一种关于临时保护皮肤颜色的产品的光保护和/或施用或施用的指示。