

(19)



(11)

**EP 2 545 854 B1**

(12)

**EUROPEAN PATENT SPECIFICATION**

(45) Date of publication and mention of the grant of the patent:  
**04.06.2014 Bulletin 2014/23**

(51) Int Cl.:  
**A61B 5/155** <sup>(2006.01)</sup> **A61B 5/00** <sup>(2006.01)</sup>  
**A61B 5/145** <sup>(2006.01)</sup>

(21) Application number: **12004290.8**

(22) Date of filing: **25.04.2008**

(54) **Instrument and system for producing a sample of a body liquid and for analysis thereof**

Instrument und System zum Erzeugen einer Körperflüssigkeitsprobe und Analyse derselben

Instrument et système pour produire un échantillon d'un corps liquide et analyse correspondante

(84) Designated Contracting States:  
**AT BE BG CH CY CZ DE DK EE ES FI FR GB GR HR HU IE IS IT LI LT LU LV MC MT NL NO PL PT RO SE SI SK TR**

(30) Priority: **30.04.2007 US 914897 P**

(43) Date of publication of application:  
**16.01.2013 Bulletin 2013/03**

(62) Document number(s) of the earlier application(s) in accordance with Art. 76 EPC:  
**08749134.6 / 2 152 163**

(73) Proprietors:  
 • **Roche Diagnostics GmbH**  
**68305 Mannheim (DE)**  
 Designated Contracting States:  
**DE**  
 • **F.Hoffmann-La Roche AG**  
**4070 Basel (CH)**  
 Designated Contracting States:  
**AT BE BG CH CY CZ DK EE ES FI FR GB GR HR HU IE IS IT LI LT LU LV MC MT NL NO PL PT RO SE SI SK TR**

(72) Inventors:  
 • **Kraemer, Uwe**  
**68549 Ilvesheim (DE)**  
 • **Zimmer, Volker**  
**54497 Morbach (DE)**  
 • **Roedel, Wolfgang**  
**69123 Heidelberg (DE)**  
 • **Frey, Stephan-Michael**  
**64347 Griesheim (DE)**  
 • **Hoerauf, Christian**  
**68723 Offersheim (DE)**  
 • **Patel, Paul**  
**Sunnyvale**  
**CA 94086 (US)**

(74) Representative: **Durm & Partner**  
**Patentanwälte**  
**Moltkestrasse 45**  
**76133 Karlsruhe (DE)**

(56) References cited:  
**EP-A- 1 360 933 EP-A- 1 527 737**  
**US-B1- 6 589 260**

**EP 2 545 854 B1**

Note: Within nine months of the publication of the mention of the grant of the European patent in the European Patent Bulletin, any person may give notice to the European Patent Office of opposition to that patent, in accordance with the Implementing Regulations. Notice of opposition shall not be deemed to have been filed until the opposition fee has been paid. (Art. 99(1) European Patent Convention).

## Description

**[0001]** The invention relates to the collection of samples of body liquid for allowing analysis thereof, i.e. determination of an analyte concentration therein. In particular it relates to instruments and systems for producing a small sample of body liquid by piercing the skin of a subject (human or animal) using a disposable lancing element having a skin piercing tip suitable for generating a small wound from which the sample is drawn. Depending on the skin site used and on the lancing depth the body liquid is blood or interstitial liquid or a mixture thereof.

**[0002]** Analysis based on skin-piercing is important in several fields of medical diagnostics and treatment. Of particular importance is the field of diabetes management. It has been determined that severe long term damages caused by diabetes mellitus can be avoided if the patient controls her or his blood sugar level several times a day in order to adapt the required insulin injections closely to the actual need for maintaining a constant blood sugar level. This requires so called "home-monitoring" by the patient himself or by other people not having a medical training.

**[0003]** Other important fields of medical diagnostics and treatment with similar requirements, including home-monitoring, refer for example to the regular control of blood cholesterol and to the control of blood coagulation parameters. The invention is in particular suitable but not limited to home-monitoring applications. Similar requirements also exist, e.g., in so called "near-patient-testing".

**[0004]** Lancing of the skin is generally performed by a lancing system comprising, as mutually adapted components of the system, a reusable hand-held instrument and lancing elements. The movement required for lancing (puncturing movement) is driven by a lancing drive provided inside a housing of the instrument and adapted for driving a lancing element connected thereto. Lancets can be interchangeably connected to the drive and generally are disposable items.

**[0005]** After triggering the puncturing movement the lancet is driven in a puncture direction until it reaches a point of maximum displacement and thereafter it is further driven in a reverse direction. Many suitable lancet drive mechanisms have been described. In most cases the driving force is supplied by a tensioned spring and the lancet drive further includes suitable mechanical means for converting the force of the spring into the required movement of a lancet.

**[0006]** An important consideration in developing lancing systems is the pain caused by the pricking action. This pain and the convenience of use are decisive factors determining compliance of the patient, i.e. his willingness to perform regular analyses as required for maintaining his health. It has been determined that reliable production of the required amount of sample liquid with minimum pain highly depends on the reproducibility of an optimum penetration depth of the tip of the lancing element into

the skin (see US-patent 5,318,584).

**[0007]** With earlier lancet systems the analysis generally required a plurality of steps to be performed by the user. After lancing with such earlier systems the blood did not readily emanate from the wound site in the lanced skin. Therefore manual "milking" steps such as pinching, squeezing and kneading where necessary in order to express the required amount of sample liquid. Finally sample liquid was contacted to an analysis element of an analysis system (which was separate and distinct from the lancing system) and the analysis was performed thereby.

**[0008]** In order to improve the production of sample liquid at the lancing site and to avoid the manual "milking" several proposals were made all of which relate to the design of the contact area at a distal end of the lancing instrument having a (generally ring-shaped) skin contact surface surrounding a skin contact opening. Such lancing systems are described in

WO 99/26539

WO 01/89383 A2

EP 1 245 187 A1

EP 1 586 269

EP 1 586 270

**[0009]** While these approaches differ in several ways, a common feature thereof is that the skin contact opening has a relatively large diameter whereby the skin bulges into the skin contact opening forming a target site bulge which penetrates to some extent into the opening when the lancing instrument is pressed with its distal end (i.e. with the skin contact surface) against the skin. This bulging action (hereafter designated "target site bulging") is generally combined with additional means for improving sample liquid production, such as a mechanical squeezing acting radially inwardly, a pumping action involving axial movement of parts of the instrument, etc. For example, US patent 6 589 260 describes a system using a compression unit made of a deformable material having a ring-shaped pressure-application region formed to partially convert a pressure which is applied in a primary direction (downward) into a movement of the ring-shaped pressure application region in a secondary direction (radially inwardly).

**[0010]** Ideally these measures allow with a high success rate (preferably better than 90 %) expression of a sufficient amount of sample liquid without manual "milking". This again is a requirement of integrated lancing and analysis systems which, in a single instrument, comprise both, means for the lancing-type sample production and means for the analysis. Such integrated systems have been proposed in a plurality of variants which can be assigned to two types, namely

A) "Two unit systems" having - in a single instrument housing - two separate units for lancing and for analysis. Typically the units are moved one after the other to a common skin contact opening (see e.g. EP 1 669 028 A1, EP 1 736 100 A1 and US 6 589 260 B1).

B) "Single unit systems" operating with a single combined lancing- and analysis unit suitable for performing both functions (lancing and analysis). Most such systems operate with integrated lancing and analysis elements. The two components of such combined lancing and analysis elements are generally manufactured separately but assembled by the manufacturer or at least before use, i.e. before the lancing movement is triggered. In the instrument such elements are processed as a unified item. In other single unit systems both functions (lancing and analysis) are performed by the same unit but a lancing element and an analysis element are provided and processed separately during at least a part of the analytical procedure. Examples of single unit systems are described in the following publications:

WO 01/72220

WO 03/009759 A1

EP 1 342 448 A1

EP 1 360 933 A1

EP 1 362 551 A1

**[0011]** Even though several of the discussed systems, in particular integrated lancing and analysis systems, provide improved results as compared to earlier known devices, there are still substantial shortcomings. There is a need for improvements with respect to several partially contradictory requirements including ease of use, minimum pain and minimum requirements concerning volume, weight and production cost.

**[0012]** With a view to this aim the invention proposes an instrument according to claim 1 and a system according to claim 12.

**[0013]** The invention relates to target site bulging when a lancing instrument is pressed against the skin (or vice versa) at the lancing site. While this bulging is favorable regarding expression of a sufficient amount of sample liquid it causes a problem regarding reproducibility of the penetration depth by which the tip of the lancing element penetrates into the skin. With a given adjustment of the longitudinal position (i.e. position in the direction of the lancing movement; hereafter "z-position") of the lancing drive and consequently a given z-position of the point of maximum displacement of the lancet the penetration depth depends on the exact z-position of the skin surface during the puncturing movement. Due to the bulging this skin position is substantially undefined. It depends on a

plurality of factors including not only differing skin elasticity of different users but also including changes of the (elastic and other) properties of the skin of a particular user caused by influencing factors such as temperature, previous skin treatment (e.g. washing with soap) and choice of the particular lancing site. Prior art approaches for overcoming this uncertainty about the skin position and the resulting uncertainty about the penetration depth include the following:

- Detection of the exact z-position of the skin by a skin position detection device integrated into the lancing instrument and operating for example by electric (capacitive) or optical detection means (WO 03/088835).
- Providing in the instrument a penetration depth reference element having a reference skin contact surface which is contacted to the skin (additionally to the skin contact surface surrounding the skin contact opening of the instrument), for providing a reliable z-position reference during penetration of the lancing element tip into the skin. Such a reference element can be moved towards the skin separately from the lancing element (EP 1 669 028 A1) or together therewith (WO2006/092309).
- A variant of the latter approach is described in EP 1 527 737 A1. A reference for the z-position of the skin bulging into the opening is provided by a so-called "trigger mechanism" which controls the location of the target site bulge relative to the housing of the device.

**[0014]** While these approaches help to achieve a reproducible penetration depth they require a substantial expense in the instrument design and production, making the system less handy and more costly. Therefore several of the lancing systems designed for target site bulging simply disregard the penetration depth uncertainty. This approach causes, however, a much larger pain than necessary, because it requires a high value of the penetration depth setting to make sure that a sufficient amount of sample liquid is produced even with a disadvantageous position of the lancing site bulge.

**[0015]** In the context of the invention it has surprisingly been found that an excellent reproducibility of the z-position of the skin bulge at the lancing site and thus an excellent reproducibility of the penetration depth can be achieved if particular conditions are ensured concerning the size of the skin contact opening and concerning the force by which the pressure ring and the skin are pressed against each other at the time of triggering the puncturing movement. This allows to use target site bulging and automatic sample generation (without "milking") combined with a simple and inexpensive design of the lancing system. The system works without a z-position detection means and without a penetration depth reference ele-

ment adapted for contacting the skin which bulges into the pressure ring.

**[0016]** Generally the skin contact opening is circular and in this case it should have an inner (free) diameter of at least 3 mm, preferably at least 4 mm, more preferably at least 5 mm and most preferably at least 5.5 mm. The upper limit of the preferred range of diameter is 8 mm, preferably 7 mm, more preferably 6.5 mm and most preferably 6 mm. In case of a noncircular skin contact opening the area of the opening should correspond (i.e. be the same) as the area of a circle with the mentioned diameter values. However, in any case, the smallest inner (free) width of a noncircular skin contact opening should be at least 3 mm, preferably at least 4 mm.

**[0017]** The pressing force acting at the time of triggering the puncturing movement between the pressure ring and the skin should at least be 3 N, preferably 4 N and more preferably 5 N and it should at most be 8 N, preferably 7 N and more preferably 6 N. A defined pressing force within these limits is ensured by a suitable pressing force control device. Such a device can be mechanical, in particular comprising a spring device which is arranged in such a manner that its spring force acts between the pressure ring and the housing. The spring device is preferably embodied as a metal spring. Other spring-like devices are, however, known and can be used, such as a pneumatic spring or a resilient element of an elastic material. Hereafter the term "spring" is used as an example of any such spring device. Preferably is pre-tensioned, as will be described in more detail below.

**[0018]** Pressing force control devices operating by electrical means may comprise an electromagnetic drive including a coil and a magnetic core, in particular a voice coil drive. The control of the pressure can be fully automatic or it can require an activity of the user. In the latter case electrical means can be used to measure the force by which the pressure ring is pressed against the skin and this force can be indicated to the user by suitable visible, acoustic or tactile means, whereby the user can adapt the pressing force to the desired value.

**[0019]** Preferably the instrument has a holding device adapted for holding an analysis element in the housing such that a sample of body liquid produced by piercing the skin can be transported thereto for analysis.

**[0020]** A minimum interaction time period required for lancing and sampling a sufficient amount of sample liquid for analysis is preferably at most 3 seconds. More preferably the minimum interaction time period is no more than 2 seconds and most preferably it is no more than 1 second.

**[0021]** This relates to integrated lancing and analysis systems of both types A and B identified above. In such systems the user interacts with the system by establishing a pressing force between the skin and the pressure ring of the instrument. This can conveniently be done by pressing a hand-held instrument against the finger or other body part. Alternatively the finger or other body part can be pressed against an instrument, lying e.g. on a

table.

**[0022]** According to the prior art, timing has in this context generally been only a concern with respect to the "test time", i.e. the total time required for the analysis (from lancing until the analyte concentration is indicated). The inventors have found that - deviating from earlier understanding - the duration of the minimum interaction time period ("MITP") is highly critical for achieving the partially contradictory requirements mentioned above. This time period is defined as the minimum time duration for which user-instrument interaction (as specified above) is required for lancing and for collecting a sufficient amount of sample for the analysis in a sample collection device of the system. The functions performed during the MITP include lancing, expression of sample liquid from the tissue (preferably directly into a capillary of the lancing element) and collecting a sufficient amount of sample.

**[0023]** The MITP is a system-related quantity which is user-independent, i.e. only determined by the design of the instrument, and possibly by other components of the system. It must not be confused with the actual time of interaction which in each case depends on numerous aspects including the habits of the user. The actual interaction time generally varies between users and, even for a specific user, from analysis to analysis. The invention teaches to design the system in such a manner, that the minimum time for which every user must at least interact with the instrument, is below the indicated very small threshold values.

**[0024]** The starting point of the MITP is a point in time at which the system is "ready for lancing", i.e. the lancing drive is ready for driving a lancing movement of a lancing element connected thereto and the desired lancing site of the skin is properly located at the skin contact opening of the instrument. Depending on the design of the system a short period of time may be required between establishing the status "ready for lancing" and the triggering of the puncturing movement. Such a short (preparatory) delay period may be required by the instrument, for example for detecting the skin position. Preferably, however, the design is such that no such preparatory time period is needed due to instrumental requirements, i.e. the triggering can immediately take place when the status of the system is "ready for lancing". In this case the starting point of the MITP may coincide with the triggering of the puncturing movement.

**[0025]** A very short and well defined preparatory delay period may, however, be provided for non-instrumental reasons, in particular to take into account visco-elastic deformation of the skin which takes place after establishing a pressure force between the skin and the pressure ring.

**[0026]** The end of the MITP is marked by the fact that a sufficient amount of body liquid has been sampled, i.e. is available in the sample collection device of the instrument for analysis. A "sample collection device" as used herein is any part of the system, inside the instrument,

in which sample liquid produced as a result of skin lancing is available for analysis. It can, for example, be a chamber or capillary and can be empty, or filled with bibulous material.

**[0027]** Details depend on the type and design features of the particular system.

- In the case of a "two unit system" the sample collection device belongs to the analysis unit. It can be a part of an analysis element or of a dedicated sample collection element and collects sample after the analysis unit has been moved to the skin contact opening.
- In the case of a "single unit system" the sample collection device can be a part of a lance element, a part of an analysis element, a part of an integrated lancing and analysis element or a part of a dedicated sample collection element.
- If the sample collection device is a part of an analysis element or of an integrated lancing and analysis element it can, in particular, be a part of a reaction zone thereof containing reagents which react with the sample liquid, thereby producing some kind of measurable physical change which is characteristic for the analysis.
- Preferably the sample collection device is separate from the reaction zone of the analysis element and includes a reservoir, which is suitable for storing a sample liquid for an intermediate storage time which is longer than the MITP. One advantage of this embodiment is that it allows to separate the timing requirements of the sample collection from the timing requirements of the analysis. The MITP is terminated as soon as the reservoir of the sample collection device contains a sufficient amount of sample liquid for the analysis. Further steps, including for example the filling of a reaction zone, can take place separately without continued interaction of the user.
- In the last mentioned preferred embodiment the transfer of the sample liquid from the reservoir of the sample collection device to the reaction zone of the analysis element can either take place spontaneously or with controlled timing. In the former case permanent fluid communication is provided between the reservoir and the reaction zone. In the latter case the fluid communication from the reservoir of the sample collection device to the analysis element is "switchable", i.e. initially, preferably at least for the duration of the MITP, there is no fluid communication but same is established in a controlled manner at a suitable point of time. Suitable means for such switching are known for example from WO 2005/084546.

**[0028]** As noted above the MITP is a user-independent

quantity which depends only on the design of the system. Preferably, however, the instrument comprises a MITP controlling device. This term refers to any device which helps to make sure that the required interaction between the user and the instrument (i.e. mainly the required pressing force between the skin and the pressure ring) is maintained by the user at least during the MITP. In other words the MITP controlling device provides assistance to make sure that the actual interaction between the user and the instrument overlaps (or at least coincides with) the MITP.

**[0029]** The MITP controlling device need not operate fully automatically in the sense that no acts of the user, such as manual triggering of the puncturing movement, are required. Rather it may provide assistance to the user, in particular by signaling to the user directly or indirectly the start and the end of the MITP.

**[0030]** The MITP controlling device comprises means for detecting the starting point of the MITP, by detecting the pressing force acting between a pressure ring and the skin using any suitable means (to be discussed in more detail below). When the pressure corresponds to a predetermined minimum value or range this status can be indicated to the user by a suitable visible, audible or tactile signal. Alternatively the lancing movement can be triggered automatically when the status "ready for lancing" has been detected. In this case there may be no delay between "ready to lance" and triggering, i.e. the MITP starts with the automatic triggering. Alternatively there may be an instrument-controlled delay time, e. g. to take into account the time needed for visco-elastic skin-deformation. In such cases the preparatory delay period between "ready to lance" and triggering is preferably at most 1 sec, more preferably at most 0.7 sec and most preferably at most 0.5 sec. A preferred lower limit is 0.2 sec, at least 0.3 sec being more preferred and at least 0.4 sec being most preferred.

**[0031]** The end of the MITP period is generally indicated to the user by a suitable visible, audible or tactile signal.

**[0032]** It should be noted, that a dedicated MITP controlling device is not necessary for the invention in its most general sense. Depending on the particular situation it may be sufficient for the user to be provided with an indirect indication of the start and end of the MITP. For example the "ready to lance"-status can be "felt" by the user when pressing his finger on a spring-supported pressure ring (to be described in more detail below) and the duration of the MITP may be so short, that it may be sufficient to rely on the "feeling" of the user with respect to the end of the MITP.

**[0033]** The instrument may have some kind of fill control (as part of the MITP controlling device) indicating a sufficient amount of sample liquid or allowing an analysis only if a sufficient amount of sample has been collected. However, in many cases such fill control is not required. Rather the end of the MITP is calculated by the instrument using a fixed MITP value (depending on the design of

the system components).

**[0034]** In the context of the invention it has been found that substantial advantages are achieved with integrated lancing and analysis systems if the described pressing force between the pressure ring at the distal end of the lancing instrument and the skin is maintained not only at the time of lancing but also for a short interaction period thereafter:

- With both types A and B of integrated lancing and analysis systems, maintaining this pressing force for a MITP helps to produce a sufficiently large volume of sample liquid.
- In the case of type A (two unit systems) maintaining a MITP with the described pressing force is furthermore important to make sure that the position of the instrument (i.e. its skin contact opening) relative to the skin is fixed until the point of time that the analysis device is moved to the skin contact opening.
- With systems of type B (single unit systems) it has been found that maintaining a MITP with the described pressing force is important in order to allow a precise z-position of the lancing tip, thereby improving suctioning of a sufficient amount of sample liquid during a short period of time.

**[0035]** Furthermore it has been found in the context of the invention that many users of integrated lancing and analysis systems have problems to maintain a sufficient pressing force for a sufficient period of time and that compliance with recommended rules of using the instrument is much better with a system incorporating the features described here.

**[0036]** It has been found, that with suitable adaption of the minimum pressing force and (preferably) also of the upper limit of the pressing force, and (most preferably) the maximum variation range, advantageously combined with a size of the skin contact opening explained above, it is even possible and preferred to design the instrument with no user-setable penetration depth adjustment means. Surprisingly with a single factory-set z-position of the lancet drive (point of maximal displacement) and of the pressure ring, relative to each other, a reliable production of sample liquid is possible with very little pain. Simultaneously omission of a penetration depth adjustment device allows a simple, compact and inexpensive design of the instrument.

**[0037]** Even if a user-setable penetration depth adjustment device is provided, the invention allows to use a simple and inexpensive design thereof. For example in order to adapt for small remaining variations of the skin position it may be sufficient to provide interchangeable distance elements or pressure rings to allow a single adaption of the systems to the needs of a particular user.

**[0038]** In general the instrument and system of the invention take into account the viscoelastic properties of

the skin in an optimized manner. In this way not only a sufficient supply of sample liquid is ensured but also "flooding" by too much sample liquid is avoided. The invention allows reliable analysis even with very small sample volumes in the order of less than 300 nl, preferably less than 200 nl.

**[0039]** The invention is hereafter described in more detail with reference to preferred embodiments shown in the drawings. The technical features and elements shown therein can be used individually or in combination to design embodiments of the invention. In the drawings

Fig. 1 shows a schematic sketch relating to the principles of target site bulging;

Fig. 2 shows a perspective view of an analysis instrument;

Fig. 3 shows a longitudinal section of the instrument shown in Figure 2;

Fig. 4 shows a perspective view of a lancing element for use in the instrument shown in Figure 3;

Fig. 5 shows a schematic sketch regarding an aspect of the function of the instrument shown in Figure 3.

**[0040]** Figure 1 shows a view of a pressure ring 1 against which a finger tip 2 is pressed with force F. Due to this pressing force the skin 3 bulges into the skin contact opening 4 defined by pressure ring 1, forming a target site bulge 6.

**[0041]** The degree of such target site bulging, i.e. the distance d between the plane of pressure ring 1 and the apex of target site bulge 6 is influenced in a complicated manner by numerous factors including the size of the skin contact opening 4, the pressing force F and the viscoelastic properties of the skin. These again depend on a plurality of factors including

- the elasticity of the skin surface of the particular individual which largely differs depending on age, sex and degree of manual work generally performed by the particular person
- the internal pressure in the finger or other body part which depends among others on the health status and the physical activity of the particular person
- ambient conditions, including in particular temperature and humidity, influencing the viscoelastic properties of the skin
- skin treatment preceding the lancing, such as washing with soap, disinfecting etc.

**[0042]** Figure 1 also shows symbolically the point P of

maximum displacement which a piercing tip 7 reaches on its movement path during the puncturing movement. With most lancing instruments the z-positions of the plane of the pressure ring 1 and the point of maximum displacement P relative to each other (i.e. distance s shown in Figure 1) can be adjusted in order to allow a penetration depth setting. Figure 1 clearly shows that for a given value of this adjustment the actual penetration depth x depends directly on the distance d, i.e. the degree of target site bulging.

**[0043]** As noted above, in the prior art this uncertainty about the actual z-position of the skin (i.e. the apex of the target site bulge) has either been disregarded or has been taken into account by measuring or referencing the actual skin position. In the context of the invention it has surprisingly been found that a very good reproducibility of the penetration depth during lancing can be achieved if the above specified conditions concerning the area of the skin contact opening and the amount of the pressing force are maintained.

**[0044]** Figures 2 to 5 show a suitable lancing system 10. It includes a reusable hand-held instrument 11 and a disposable lancing element 12 with a piercing tip 7. A housing 13 of the instrument contains a lancing drive 14 and a measurement and evaluation electronics 15 shown only symbolically as a block in Figure 3. A display 16 is provided in order to allow visual indication of information (including status information concerning the system, advice concerning its handling, analytical results etc.) to the user. Optionally the instrument also comprises a MITP controlling device 17, a device 18 for generating audible signals (such as a buzzer) and/or a device 19 for generating tactile signals (such as a vibration generator).

**[0045]** In a preferred embodiment (best shown in Figure 4) lancing element 12 is combined with an analysis element 21, thereby forming an integral lancing and analysis element 22. In this integral element the lancing element 12 is movable in a longitudinal direction symbolized by double arrow 34. An analysis element holder 20 is provided for holding the analysis element 22 inside the instrument 11. In the embodiment shown analysis element holder 20 comprises a coupling recess 25 in analysis element 21 and a corresponding coupling protrusion 27 of the instrument. In a similar manner the lancing element 12 has a coupling recess 24 cooperating with a coupling protrusion 26 of the instrument. These pairs of recesses 24,25 and protrusions 26,27 penetrating into the respective coupling recesses allow the handling of an integral lancing and analysis element 22 which has been inserted into the instrument (Figure 3).

**[0046]** The lancet drive 14 shown in Figure 3 comprises a drive rotor 29 with a cam 30 formed by a groove. Cam 30 and a corresponding cam traveler 31 form a cam drive mechanism which controls a pivoting movement of a drive rod 32 about a pivoting axis 33.

**[0047]** After triggering of a puncture movement (by triggering means not shown) drive rotor 29 turns with high speed (driven by a drive spring also not shown) about its

axis 35 and this rotational movement is translated by means of the cam curve formed by groove 30 and traveled by cam traveler 31 into a corresponding pivoting movement of drive rod 32 which again drives a corresponding up and down movement of lancing element 12 to which it is connected by its coupling protrusion 26 penetrating into coupling recess 24. Similar rotor drives for lancing instruments have been described elsewhere. Thus no more detailed description is necessary.

**[0048]** In the preferred embodiment shown in Figure 4 the lancing element 12 is a "direct sampler" having a capillary channel 28 inside its piercing tip 7 and leading up to a sample collection zone 23 of lancing element 12. In sample collection zone 23 capillary channel 28 widens to form a sample reservoir chamber 28a.

**[0049]** During lancing, lancing element 12 performs a puncturing movement by which piercing tip 7 is driven into skin 3. Thereafter, preferably during a retraction phase of the puncturing movement, after the piercing tip 7 has reached its point of maximum displacement (but with the piercing tip still being below the surface of skin 3) sample liquid penetrates - driven by capillary forces - into capillary 28 and reservoir chamber 28a. Thus, in the embodiment shown, capillary 28 and reservoir chamber 28a together form a sample collection device 36 suitable for storing sample liquid, ready for subsequent transfer to an analysis zone 8 of analysis element 21.

**[0050]** Once sample liquid has arrived at sample collection zone 23 it may be transferred to the adjacent analysis zone 8 of analysis element 21 by means of a suitable fluid communication device. Preferably the arrangement is such that in a first configuration no fluid communication between the sample collection zone of lancing element 12 and the analysis element 21 is provided whereas in a second configuration fluid communication takes place. The switching between both configurations can be accomplished by any suitable means, e.g. by pressing zone 23 of lancing element 12 and analysis element 21 together. A more detailed description of such preferred design of an integrated lancing and analysis element with switchable sample transfer is not necessary because it has been described elsewhere.

**[0051]** Of course the invention can also be used with integral lancing and analysis elements having a lancing part and a analysis part fixed to each other. Evidently with such an embodiment no separate holding devices for the two parts are required. Rather only one holding device is provided which simultaneously serves as lancing element holding device and as analysis element holding device.

**[0052]** While preferred devices for holding and moving a lancing element and an analysis element (or an integral lancing and analysis element) in the instrument have been described, many variants are possible. These include a design in which analysis elements and/or lancing elements are fixed to and transported by means of a tape during at least a part of the system operation.

**[0053]** A special feature of the system of the invention

relates to a pressing force control device 37 provided in the instrument 11. In the embodiment shown the pressing force control device 37 comprises a spring 38 which is embodied and arranged in such a manner that one end thereof acts against pressure ring 1 and the other end acts against the housing 13. "Acting" in this context does not require immediate contact. Rather it means that the spring exerts a force on the pressure ring and that the corresponding counter-force is (directly or indirectly) borne by the housing.

**[0054]** In the instrument shown in Figure 3 one end of spring 38 rests on a wall of housing 13 and its other end presses against a frame element 39 carrying lancing drive 14. The force of spring 38 is further transmitted from the frame element 39 to pressure ring 1 via pillar elements 40. Pressure ring 1 is embodied as part of a pressure piece 42 which is borne by a pressure ring bearing 43 of housing 13 such that it is axially movable against the force of spring 38.

**[0055]** When a user presses her or his finger tip 2 in the direction of arrow F onto pressure piece 42 with pressure ring 1, the latter moves downwardly against the force of spring 38 (or other spring device). As soon as the contact between pressure piece 42 and the housing 13 at pressure ring bearing 43 is interrupted, the force of spring 38 is balanced by the pressing-down force of the finger. In other words the force by which the pressure ring 1 is pressed against the skin is in this status controlled by the pressing force control device 37, embodied here by means spring 38.

**[0056]** The principles used in this design are more clearly apparent from figure 5 showing that spring 38 acts between housing 13 and pressure piece 42 with pressure ring 1. Drive 14 is connected in a defined spatial configuration with pressure ring 1, in such a manner that the distance between the point of maximum displacement of the lancet movement and the pressure ring 1 is independent from the compression status of the spring 38 and the corresponding axial movement of pressure piece 42. Preferably the spatial configuration and hence the distance of the pressure ring from the point of maximum displacement can be varied (between puncturing movements) to set the lancing penetration depth. It is, however, fixed during the interaction of the user with the device, i.e. from the point of time at which the pressure ring is first pressed down until the body part is removed therefrom.

**[0057]** As is well known the force of an elastic spring 38 increases linearly with its elongation (i.e. compression in the case of a compression spring as shown). In the context of the invention the force by which the pressure ring 1 is pressed against the skin shall be controlled closely, i.e. the variation thereof should not exceed the preferred limiting values given above. In order to achieve this end, spring 38 is preferably embodied and arranged in such a manner that it is pre-tensioned. This means that the spring is already compressed (or in the case of an extension spring extended) even is no pressing force

is exerted onto pressure ring 1, i.e. pressure ring 1 is in its "home" position resting on the surrounding wall (bearing 43) of housing 13. The degree of this pre-tensioning is such that the force of spring 38 acting on the pressure ring 1 varies by no more than 20 %, preferably no more than 10 % within the spring-loaded movement range of the pressure ring 1.

**[0058]** In this context it is important to make sure, that in the entire movement range the pressing-force acting between the finger 2 (or other body part) and the pressure ring 1 is controlled only by the force of spring 38 balanced by the pressing-down-force of finger 2. This condition would not be met if the movement of pressure ring 1 was influenced or limited by some kind of abutting member or obstacle acting - within its possible movement range - on ring 1. In order to meet this condition a pressure ring movement limiting arrangement 44 (figure 5) is provided by which the maximum displacement of the pressure ring 1 possible by pressing with a finger 2 or other body part is limited within a fully spring-loaded movement range of the pressure ring.

**[0059]** In the preferred embodiment shown in figure 5 this is achieved by a contact surface 46 which is arranged in the vicinity (at the outer side) of the pressure ring 1 in such a manner that a body part pressed against the pressure ring 1, and thereby moving the pressure ring, abuts against the contact surface 46. Due to this abutting, the pressure ring can not be moved further, i.e. the possible displacement of the pressure ring (by the body part pressing thereagainst) is limited. With such an embodiment the maximum displacement depends on the distance  $d_r$  by which the pressure ring protrudes from the instrument housing (contact surface 46). When pressure piece 42 with pressure ring 1 is pressed downwardly this movement is discontinued when finger tip 2 contacts the surface of housing 13 in the vicinity of the pressure ring 1.

**[0060]** In this context it is also favorable if the design is such that the maximum displacement of the pressure ring 1 during practical use is small. Preferably it should be less than 3 mm, more preferably less than 2 mm and even more preferably less than 1 mm. Therefore the distance  $d_r$  of the plane of pressure ring 1 and the adjacent housing surface should not be too large. Preferred maximum values can be calculated by adding 0.5 mm to the mentioned maximum displacement values. On the other hand  $d_r$  should not be too small, among others because it is favorable for the handling of the instrument if a protrusion of pressure ring 1 versus the adjacent housing area simplifies the finding of a suitable finger position for the user. Therefore this protrusion, i.e. the distance  $d_r$ , should be at least 0.2 mm, and preferably at least 0.5 mm.

**[0061]** In contrast to some earlier devices pressure ring 1 should be non-deformable in the sense that it should not be visibly deformed during normal use of the system. A suitable exact shape and width of the pressure ring can be determined experimentally. According to the present knowledge of the inventors it should preferably have a width of at most 3.5 mm, preferably at most 2.5

mm and more preferably at most 1 mm. A preferred minimum width is 0.5 mm, preferably 0.7 mm and more preferably 0.8 mm. The ring should protrude from any adjacent housing surface by a sufficient distance to allow easy tactile recognition thereof by the user.

**[0062]** Of course the construction part at which the pressure ring is provided can have many different shapes and designs. The term "pressure ring" refers to the ring-shaped surface of the respective part which in practical use, i.e. under the conditions prevailing in using of the particular instrument) contacts the skin surface. Of course this ring-shaped contact surface (i.e. the pressure ring) can have varying shapes including e.g. slightly rounded edges.

**[0063]** Furthermore the term "pressure ring" does not have to be understood as being limited to an uninterrupted ring. Rather the ring shaped surface contacting the skin can have interruptions (for example by recesses) which should, however, be small enough not to spoil the described function of the pressure ring.

**[0064]** In the preferred embodiment shown in Figure 3 the instrument furthermore comprises a pressure-ring-movement detection device 45. It is preferably a part of a MITP control device. Means for movement detection are well known, for example a light barrier 46 as shown symbolically in the drawing. Such a device detects the movement of pressure piece 42, and hence of pressure ring 1, upon pressing down from its "home" position by finger 2. Such detection allows several favorable functions including an indication to the user (via display 16 or generators of audible or tactile signals 18 and 19) that the instrument is "ready for lancing". Alternatively or additionally the signal of the pressure-ring-movement detection device can be used for automatically triggering the lancing movement, possibly after a delay time as described above.

**[0065]** Figure 3 furthermore shows an analysis measurement device 47 as part of the instrument 11. This can be any device which is suitable to measure a value of a measurement quantity relating to a change of analysis element 21, which change is a measure of the desired analytical value. In the case shown, the analysis measurement device is embodied for a photometric measurement of a detection area in the analysis zone 8 of analysis element 21 including a light source 48, a light detector 49 and corresponding light guide means symbolized by a lens 50. Other types of analysis measurement devices could be used as well, in particular electrical measurement devices, as are common for the evaluation of electrochemical analysis elements.

**[0066]** In the system shown in Figures 2 to 5 a MITP control device 17 makes use of the pressure-ring-movement detection device 45. Once MITP control device 17 signals the start of an MITP it generates a signal by at least one of signal generators 18 and 19 and/or automatically triggers a puncturing movement of lancet drive 14. The end of the MITP period is determined by the measurement and evaluation electronics 15, for example on

the basis of a predefined time period required for generation and transfer of sufficient amount of sample liquid from the finger tip 2. Alternatively the status of a sufficient sample transfer may be separately detected by suitable sample transfer detection means as are known in the art, e.g. photometric detection of the sample transported in the integral lancing and analysis element 22 or by electrical contacts detecting that sample liquid transported therein has reached a certain point in its transport path. Preferably - as in the embodiment shown - the application force control device makes sure that during the entire MITP the pressing force is within the range given by the above identified limiting values. Preferably the variation of the pressing force during the MITP should be within the above identified variation limitations which are much smaller.

## Claims

1. Instrument for producing a sample of body liquid for analysis by piercing the skin with a lancing element (12) having a skin piercing tip (7) said instrument (11) having

- a housing (13)
- a lancing drive (14) within said housing (13) for driving a lancing element (12) connected thereto in a puncturing movement in which the lancing element (12) moves, after triggering the puncturing movement, in a puncture direction until it reaches a point (P) of maximum displacement and in a reverse direction after it has reached the point (P) of maximum displacement,
- a pressure ring (1) surrounding a skin contact opening (4) and being adapted for pressing against the skin such that the skin (3) bulges into the opening (4) for promoting expression of body fluid,

### characterized in that

the skin contact opening (4) has an opening area corresponding to a circle with a diameter of at least 3 mm and at most 8 mm, and

the instrument comprises a pressing force control device (37) for controlling the pressing force between the pressure ring (1) and the skin (3) at the time of triggering the puncturing movement, to be at least 3 N and at most 8 N.

2. Instrument according to claim 1, wherein the opening area of the skin contact opening (4) corresponds to a circle with a diameter of at least 4 mm and at most 7 mm, preferably at least 5 mm and at most 6.5 mm, most preferably at least 5.5 mm and at most 6 mm.
3. Instrument according to any one of the preceding claims, wherein the pressing force control device

- (37) is adapted for controlling the force, by which the pressure ring (1) is pressed against the skin at the time of triggering the lancing movement, is controlled to be at least 4 N and at most 7 N, preferably at least 5 N and at most 6 N.
4. Instrument according to any one of the preceding claims, further comprising a holding device (20) for holding an analysis element (21) in said housing such that a sample of body liquid produced by piercing the skin can be transported thereto for analysis.
  5. Instrument according to any one of claims 1 to 4, comprising a device for the automatic triggering of a puncturing movement.
  6. Instrument according to any one of the preceding claims, wherein the pressing force control device (37) comprises a spring device (38) arranged such that one end thereof acts against the pressure ring and the other end acts against the housing (13).
  7. Instrument according to claim 6, wherein the lancet drive (14) is connected with the pressure ring (1) in a defined spatial configuration, such that the distance between the point of maximum displacement of the lancet movement and the pressure ring (1) is independent from the compression status of the spring (38) device and thus from the axial movement position of the pressure ring (1).
  8. Instrument according to any one of claims 6 or 7, comprising a pressure ring movement limiting arrangement (44), by which the maximum displacement of the pressure ring (1) possible by pressing with a finger (2) or other body part is limited within a spring-loaded movement range of the pressure ring.
  9. Instrument according to claim 8, wherein the pressure ring movement limiting arrangement comprises a contact surface (46) in the vicinity of the pressure ring (1) arranged such that a body part pressed against the pressure ring (1) and thereby moving the pressure ring, abuts against the contact surface (46).
  10. Instrument according to any one of claims 6 to 9, wherein the spring device is pre-tensioned such that its force acting on the pressure ring varies by not more than 20 %, preferably not more than 10 %, within the spring-loaded movement range of the pressure ring.
  11. Instrument according to any one of the preceding claims, wherein the pressure ring has a mean width of at least 0.5 mm and at most 3.5 mm, preferably at least 0.7 mm and at most 2.5 mm, most preferably at least 0.8 mm and at most 1 mm.
  12. System for producing a sample of body liquid for analysis by piercing the skin comprising a reusable hand-held-instrument (11) according to any one of the preceding claims and a lancing element (12) which is adapted to be interchangeably connected to the drive (14) of the instrument.
  13. System according to claim 12, wherein the lancing element (12) is a part of an integral lancing- and analysis element (22).
  14. System according to any one of claims 12 or 13, wherein the lancing element (12) is a direct sampler having a capillary channel (28) for transporting sample liquid produced by piercing the skin by means of capillary flow to a sample collection zone (23) thereof.
  15. System according to claims 13 and 14, comprising a fluid communication device such that sample liquid can be transferred from a sample collection zone (23) of the lancing element (12) to the analysis element (21) for analysis.

#### Patentansprüche

1. Instrument zum Erzeugen einer Körperflüssigkeitsprobe zur Analyse durch Eindringen eines Stechelements (12) mit einer Hauteinsteckspitze (7) in die Haut, wobei das Instrument (11) umfasst
  - ein Gehäuse (13),
  - einen Stechantrieb (14) in dem Gehäuse (13) zum Antreiben einer Stechbewegung eines mit dem Antrieb verbundenen Stechelementes (12), bei der sich das Stechelement (12) nach Auslösen der Stechbewegung in einer Einstichrichtung bewegt, bis es einen Punkt (P) der maximalen Auslenkung erreicht, und bei der es nach Erreichen des Punktes (P) der maximalen Auslenkung in einer Rückwärtsrichtung bewegt wird,
  - einen Druckring (1), der eine Hautkontaktöffnung (4) umgibt und dazu ausgebildet ist, derartig gegen die Haut gedrückt zu werden, dass die Haut (3) sich in die Öffnung (4) hineinwölbt, um das Austreten der Körperflüssigkeit zu fördern,

**dadurch gekennzeichnet, dass** die Hautkontaktöffnung (4) einen Öffnungsquerschnitt aufweist, der einem Kreis mit einem Durchmesser von mindestens 3 mm und höchstens 8 mm entspricht, und das Instrument eine Druckkraft-Kontrolleinrichtung (37) aufweist, um die Druckkraft zwischen dem

- Druckring (1) und der Haut (3) zum Zeitpunkt des Auslösens der Stechbewegung so zu kontrollieren, dass sie mindestens 3 N und höchstens 8 N beträgt.
2. Instrument nach Anspruch 1, wobei der Öffnungsquerschnitt der Hautkontaktöffnung (4) einem Kreis mit einem Durchmesser von mindestens 4 mm und höchstens 7 mm, bevorzugt mindestens 5 mm und höchstens 6,5 mm, am meisten bevorzugt mindestens 5,5 mm und höchstens 6 mm entspricht.
  3. Instrument nach einem der vorhergehenden Ansprüche, wobei die Druckkraft-Kontrolleinrichtung (37) dazu ausgebildet ist, die Kraft, durch die der Druckring (1) zum Zeitpunkt des Auslösens der Stechbewegung gegen die Haut gepresst wird, so zu kontrollieren, dass sie mindestens 4 N und höchstens 7 N, bevorzugt mindestens 5 N und höchstens 6 N, beträgt.
  4. Instrument nach einem der vorgehenden Ansprüche, welches weiterhin eine Halteeinrichtung (20) umfasst, um ein Analyseelement (21) in dem Gehäuse derartig zu halten, dass eine durch Einstechen in die Haut erzeugte Körperflüssigkeitsprobe zur Analyse zu dem Analyseelement transportiert werden kann.
  5. Instrument gemäß einem der Ansprüche 1 bis 4, welches eine Einrichtung zum automatischen Auslösen der Stechbewegung aufweist.
  6. Instrument nach einem der vorhergehenden Ansprüche, wobei die Druckkraft-Kontrolleinrichtung (37) eine Federeinrichtung (38) umfasst, die so angeordnet ist, dass ihr eines Ende gegen den Druckring und ihr anderes Ende gegen das Gehäuse (13) wirkt.
  7. Instrument nach Anspruch 6, wobei der Stechantrieb (14) mit dem Druckring (1) in einer definierten räumlichen Anordnung derart verbunden ist, dass der Abstand zwischen dem Punkt der maximalen Auslenkung der Stechbewegung und dem Druckring (1) unabhängig vom Kompressionsstatus der Federeinrichtung (38) und folglich auch von der axialen Bewegungsposition des Druckrings (1) ist.
  8. Instrument nach einem der Ansprüche 6 oder 7, welches eine Einrichtung (44) zur Begrenzung der Druckringbewegung aufweist, durch die die maximale Auslenkung des Druckrings (1), die durch Drücken mit einem Finger (2) oder einem anderen Körperteil ermöglicht wird, innerhalb eines federgelagerten Bewegungsbereichs des Druckrings begrenzt ist.
  9. Instrument nach Anspruch 8, wobei die Einrichtung zur Begrenzung der Druckringbewegung eine Kontaktfläche (46) nahe des Druckrings (1) aufweist, die
- derart angeordnet ist, dass ein Körperteil, das gegen den Druckring (1) gepresst wird und dabei den Druckring bewegt, an die Kontaktfläche (46) anstößt.
10. Instrument nach einem der Ansprüche 6 bis 9, wobei die Federeinrichtung so vorgespannt ist, dass ihre auf den Druckring wirkende Kraft innerhalb des federgelagerten Bewegungsbereichs des Druckrings um nicht mehr als 20%, vorzugsweise nicht mehr als 10%, variiert.
  11. Instrument nach einem der vorhergehenden Ansprüche, wobei der Druckring eine Durchschnittsbreite von mindestens 0,5 mm und höchstens 3,5 mm, bevorzugt mindestens 0,7 mm und höchstens 2,5 mm, am meisten bevorzugt mindestens 0,8 mm und höchstens 1 mm, hat.
  12. System zum Erzeugen einer Körperflüssigkeitsprobe für die Analyse durch Einstechen in die Haut, welches ein wiederverwendbares tragbares Instrument (11) gemäß einem der vorhergehenden Ansprüche und ein Stechelement (12) umfasst, das dazu ausgebildet ist, auswechselbar mit dem Antrieb (14) des Instruments verbunden zu werden.
  13. System nach Anspruch 12, wobei das Stechelement (12) ein Teil eines integrierten Stech- und Analyseelements (22) ist.
  14. System nach einem der Ansprüche 12 oder 13, bei welchem das Stechelement (12) ein Direktsammler ist, der einen Kapillarkanal (28) zum Transport von durch Einstechen in die Haut gewonnener Probenflüssigkeit mittels Kapillarkraft zu einer Probensammelzone (23) des Direktsammlers aufweist.
  15. System nach den Ansprüchen 13 und 14, umfassend eine Flüssigkeitsübertragungseinrichtung, die derart ausgebildet ist, dass Probenflüssigkeit von einer Probensammelzone (23) des Stechelements (12) zu dem Analyseelement (21) zur Analyse übertragen werden kann.
- Revendications**
1. Instrument pour produire un échantillon de liquide corporel pour analyse en perçant la peau avec un élément (12) de lancette ayant une pointe (7) de perçage de la peau ledit instrument (11) ayant
    - un logement (13)
    - un entraînement (14) de lancette à l'intérieur dudit logement (13) pour entraîner un élément (12) de lancette connecté à celui-ci dans un mouvement de perçage dans lequel l'élément

(12) de lancette se déplace, après déclenchement du mouvement de perçage, dans un sens de perçage jusqu'à ce qu'il atteigne un point (P) de déplacement maximum et dans un sens inverse après qu'il a atteint le point (P) de déplacement maximum,

- une bague (1) de pression entourant une ouverture (4) de contact avec la peau et étant adaptée à presser contre la peau de façon à ce que la peau (3) saille dans l'ouverture (4) pour favoriser une expression de fluide corporel,

#### caractérisé en ce que

l'ouverture (4) de contact avec la peau a une superficie d'ouverture correspondant à un cercle avec un diamètre d'au moins 3 mm et d'au plus 8 mm, et l'instrument comprend un dispositif (37) de contrôle de force de pression pour contrôler la force de pression entre la bague (1) de pression et la peau (3) au moment du déclenchement du mouvement de perçage, de façon à ce qu'elle soit d'au moins 3 N et d'au plus 8 N.

2. Instrument selon la revendication 1, dans lequel la superficie d'ouverture de l'ouverture (4) de contact avec la peau correspond à un cercle avec un diamètre d'au moins 4 mm et d'au plus 7 mm, préférablement au moins 5 mm et au plus 6,5 mm, le plus préférablement au moins 5,5 mm et au plus 6 mm.
3. Instrument selon l'une quelconque des revendications précédentes, dans lequel le dispositif (37) de contrôle de force de pression est adapté à contrôler la force, par laquelle la bague (1) de pression est pressée contre la peau au moment du déclenchement du mouvement de perçage, de façon à ce qu'elle soit au moins 4 N et au plus 7 N, préférablement au moins 5 N et au plus 6 N.
4. Instrument selon l'une quelconque des revendications précédentes, comprenant en outre un dispositif (20) de maintien pour maintenir un élément (21) d'analyse dans ledit logement de façon à ce qu'un échantillon de liquide corporel produit en perçant la peau puisse être transporté jusqu'à celui-ci pour analyse.
5. Instrument selon l'une quelconque des revendications 1 à 4, comprenant un dispositif pour le déclenchement automatique d'un mouvement de perçage.
6. Instrument selon l'une quelconque des revendications précédentes, dans lequel le dispositif (37) de contrôle de force de pression comprend un dispositif (38) à ressort agencé de telle manière qu'une extrémité de celui-ci agit contre la bague de pression et que l'autre extrémité agit contre le logement (13).
7. Instrument selon la revendication 6, dans lequel l'entraînement (14) de lancette est connecté avec la bague (1) de pression dans une configuration spatiale définie, de telle sorte que la distance entre le point de déplacement maximum du mouvement de lancette et la bague (1) de pression est indépendante du statut de compression du dispositif (38) à ressort et ainsi de la position en mouvement axial de la bague (1) de pression.
8. Instrument selon l'une quelconque des revendications 6 ou 7, comprenant un agencement (44) de limitation de mouvement de bague de pression par lequel le déplacement maximum de la bague (1) de pression possible en pressant avec un doigt (2) ou autre partie du corps est limité à l'intérieur d'une plage de mouvement de ressort de la bague de pression.
9. Instrument selon la revendication 8, dans lequel l'agencement de limitation de mouvement de bague de pression comprend une surface (46) de contact à proximité de la bague (1) de pression agencée de telle manière qu'une partie du corps pressée contre la bague (1) de pression et déplaçant ainsi la bague de pression vient buter contre la surface (46) de contact.
10. Instrument selon l'une quelconque des revendications 6 à 9, dans lequel le dispositif à ressort est précontraint de façon à ce que sa force agissant sur la bague de pression ne varie pas de plus de 20%, préférablement pas de plus de 10%, à l'intérieur de la plage de mouvement de ressort de la bague de pression.
11. Instrument selon l'une quelconque des revendications précédentes, dans lequel la bague de pression a une largeur moyenne d'au moins 0,5 mm et d'au plus 3,5 mm, préférablement au moins 0,7 mm et au plus 2,5 mm, le plus préférablement au moins 0,8 mm et au plus 1 mm.
12. Système pour produire un échantillon de liquide corporel pour analyse en perçant la peau comprenant un instrument (11) à main réutilisable selon l'une quelconque des revendications précédentes et un élément (12) de lancette qui est adapté à être connecté de façon interchangeable à l'entraînement (14) de l'instrument.
13. Système selon la revendication 12, dans lequel l'élément (12) de lancette est une partie d'un élément (22) intégré de perçage et d'analyse.
14. Système selon l'une quelconque des revendications 12 ou 13, dans lequel l'élément (12) de lancette est un échantillonneur direct ayant un canal (28) capil-

laire pour transporter un échantillon liquide produit en perçant la peau au moyen d'un écoulement capillaire jusqu'à une zone (23) de collecte d'échantillon de celui-ci.

5

15. Système selon les revendications 13 et 14, comprenant un dispositif de communication de fluide tel qu'un échantillon liquide puisse être transféré d'une zone (23) de collecte d'échantillon de l'élément (12) de lancette jusqu'à l'élément (21) d'analyse pour analyse.

10

15

20

25

30

35

40

45

50

55

Fig. 1

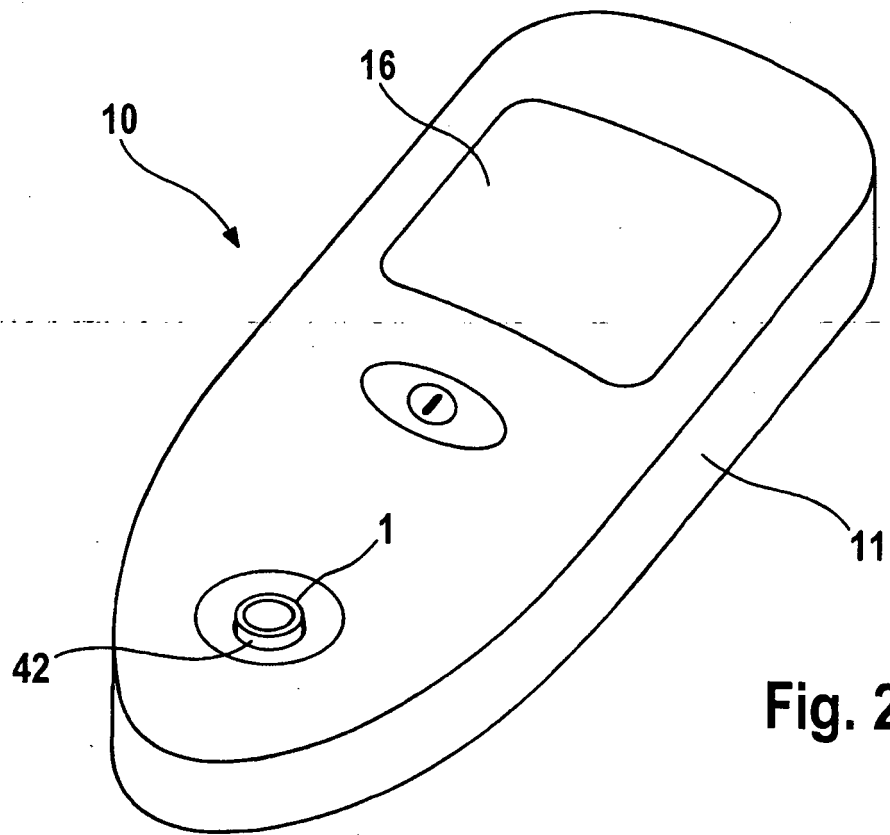
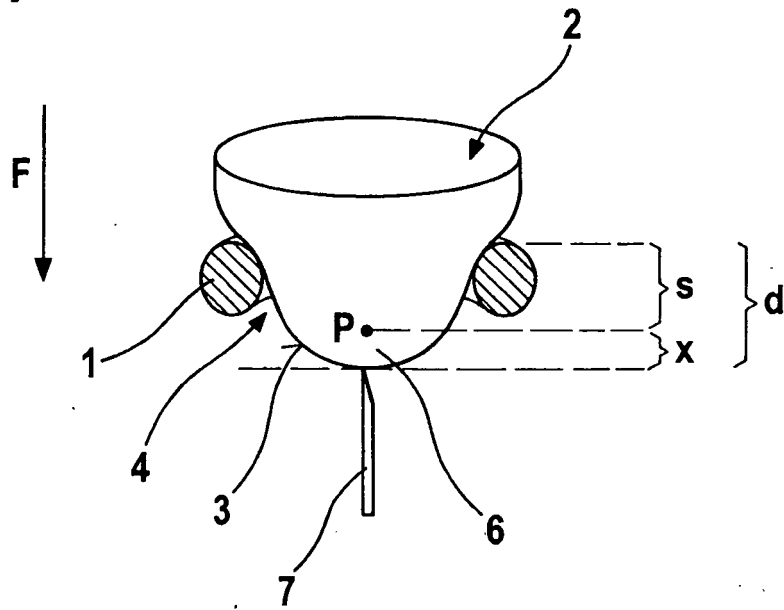

Fig. 2

Fig. 3

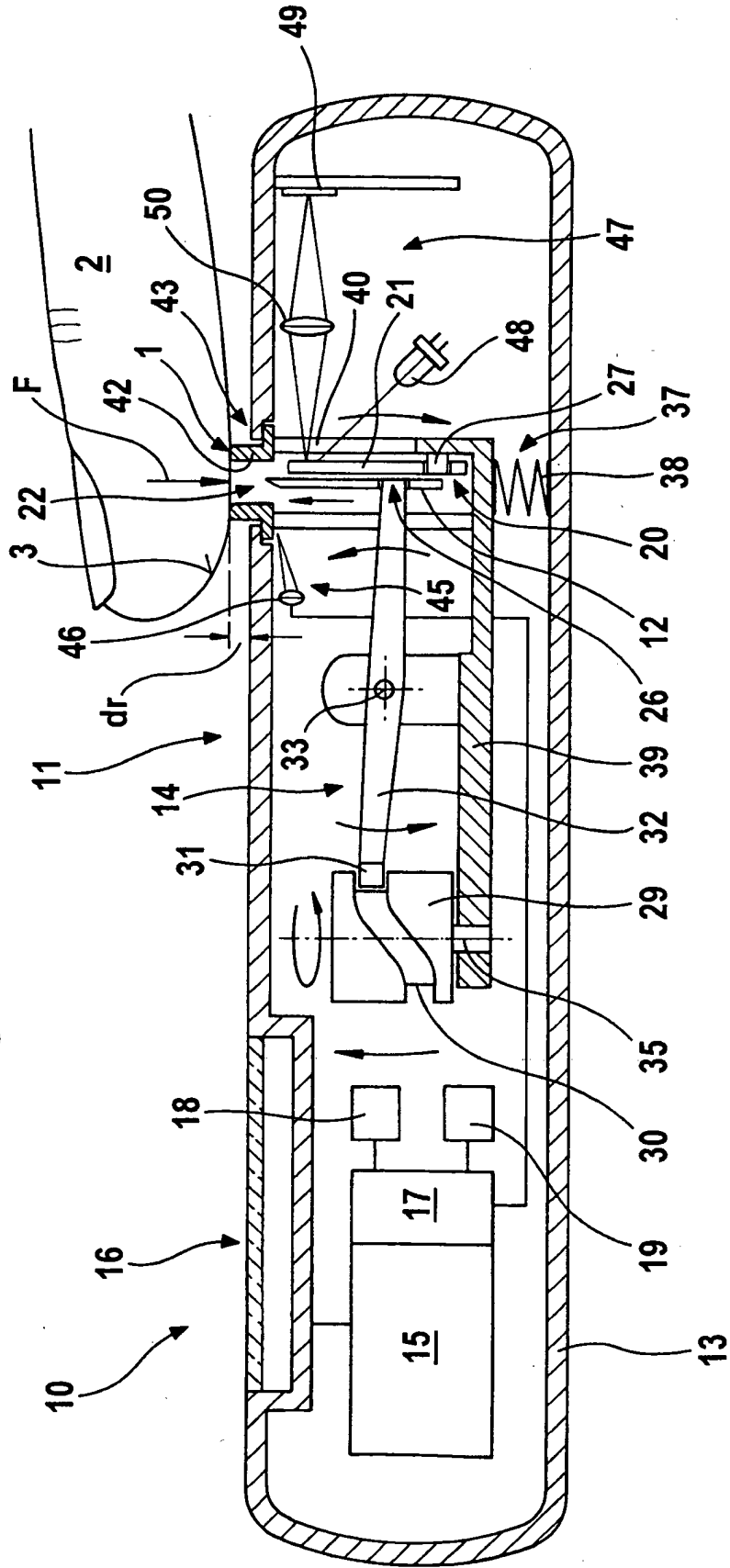

Fig. 4

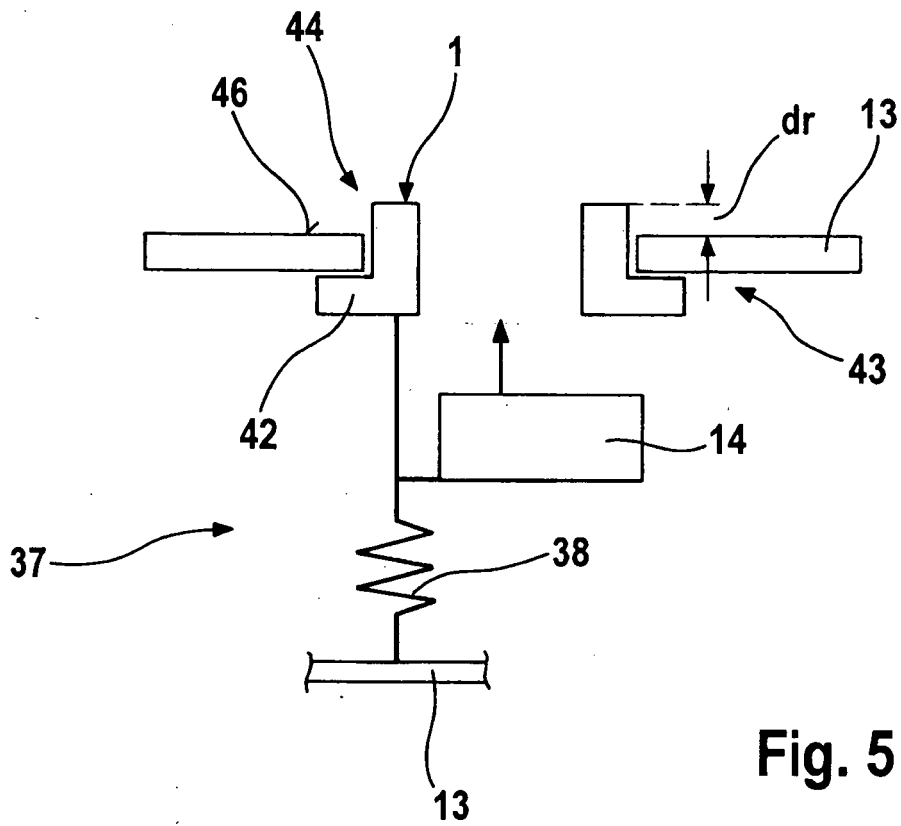
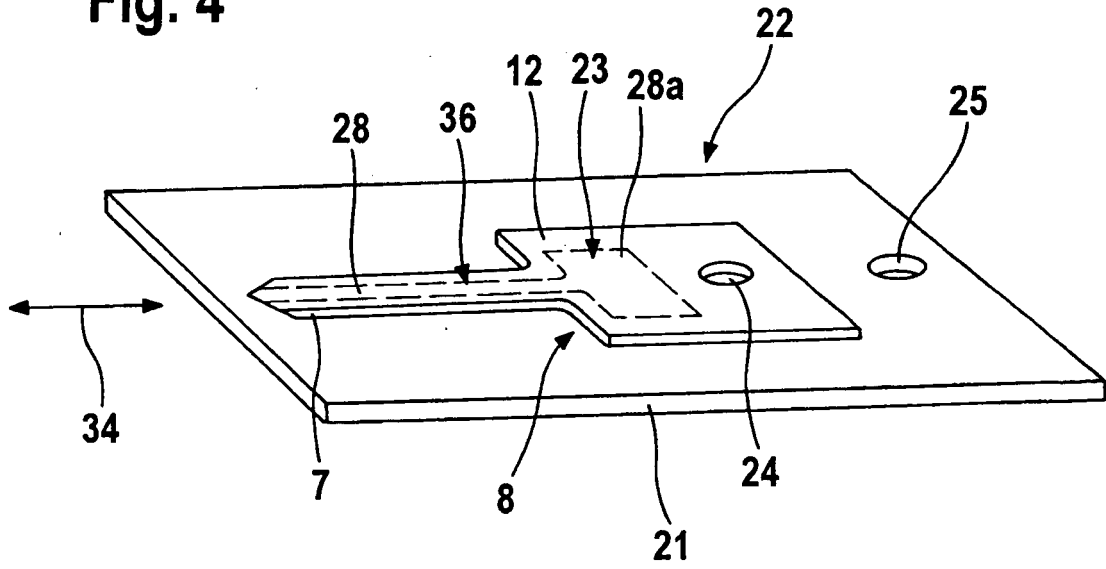

Fig. 5

**REFERENCES CITED IN THE DESCRIPTION**

*This list of references cited by the applicant is for the reader's convenience only. It does not form part of the European patent document. Even though great care has been taken in compiling the references, errors or omissions cannot be excluded and the EPO disclaims all liability in this regard.*

**Patent documents cited in the description**

- US 5318584 A [0006]
- WO 9926539 A [0008]
- WO 0189383 A2 [0008]
- EP 1245187 A1 [0008]
- EP 1586269 A [0008]
- EP 1586270 A [0008]
- US 6589260 B [0009]
- EP 1669028 A1 [0010] [0013]
- EP 1736100 A [0010]
- US 6589260 B1 [0010]
- WO 0172220 A [0010]
- WO 03009759 A1 [0010]
- EP 1342448 A1 [0010]
- EP 1360933 A1 [0010]
- EP 1362551 A1 [0010]
- WO 03088835 A [0013]
- WO 2006092309 A [0013]
- EP 1527737 A1 [0013]
- WO 2005084546 A [0027]

专利名称(译)	用于产生体液样品并用于分析的仪器和系统		
公开(公告)号	<a href="#">EP2545854B1</a>	公开(公告)日	2014-06-04
申请号	EP2012004290	申请日	2008-04-25
[标]申请(专利权)人(译)	罗氏诊断公司		
申请(专利权)人(译)	罗氏诊断有限公司 F.HOFFMANN-LA ROCHE AG		
当前申请(专利权)人(译)	罗氏诊断有限公司 F.HOFFMANN-LA ROCHE AG		
[标]发明人	KRAEMER UWE ZIMMER VOLKER ROEDEL WOLFGANG FREY STEPHAN MICHAEL HOERAUF CHRISTIAN PATEL PAUL		
发明人	KRAEMER, UWE ZIMMER, VOLKER ROEDEL, WOLFGANG FREY, STEPHAN-MICHAEL HOERAUF, CHRISTIAN PATEL, PAUL		
IPC分类号	A61B5/155 A61B5/00 A61B5/145		
CPC分类号	A61B5/14532 A61B5/1455 A61B5/150022 A61B5/150183 A61B5/150358 A61B5/150389 A61B5/150503 A61B5/15113 A61B5/15117 A61B5/15128 A61B5/1519 A61B5/15194 A61B5/157		
优先权	60/914897 2007-04-30 US		
其他公开文献	EP2545854A1		
外部链接	<a href="#">Espacenet</a>		

摘要(译)

用于通过用具有皮肤刺穿尖端的刺血元件 ( 12 ) 刺穿皮肤来产生体液样品的仪器用于分析。器械 ( 11 ) 具有壳体 ( 13 ) 和穿刺驱动器 ( 14 ) ，用于在穿刺运动中驱动与其连接的穿刺元件 ( 12 ) 。压力环 ( 1 ) 围绕皮肤接触开口 ( 4 ) 并且适于压靠皮肤，使得皮肤 ( 3 ) 凸出到开口 ( 4 ) 中以促进体液的表达。皮肤接触开口 ( 4 ) 具有对应于直径为至少3mm且至多8mm的圆形的开口区域，并且该仪器包括用于控制压力环之间的压力的压力控制装置 ( 37 ) 。（ 1 ）和触发穿刺运动时的皮肤 ( 3 ) 至少为3N且至多为8N。

Fig. 1

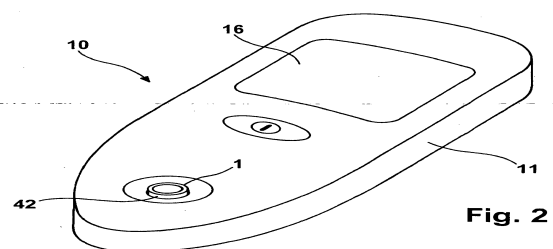
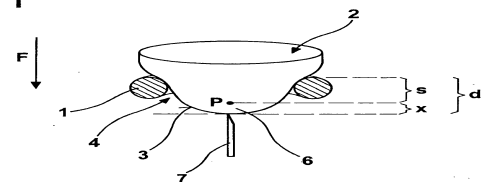

Fig. 2