

(19)



(11)

**EP 2 286 722 B1**

(12)

**EUROPEAN PATENT SPECIFICATION**

(45) Date of publication and mention of the grant of the patent:  
**06.07.2016 Bulletin 2016/27**

(51) Int Cl.:  
**A61B 5/00** <sup>(2006.01)</sup> **G01N 21/35** <sup>(2014.01)</sup>

(21) Application number: **10010019.7**

(22) Date of filing: **08.05.2006**

**(54) Patient interface for spectroscopy applications**

Patientenschnittstelle für Spektroskopieanwendungen

Interface patient pour applications de spectroscopie

(84) Designated Contracting States:  
**DE FR**

(30) Priority: **16.05.2005 US 129935**

(43) Date of publication of application:  
**23.02.2011 Bulletin 2011/08**

(62) Document number(s) of the earlier application(s) in accordance with Art. 76 EPC:  
**06727038.9 / 1 883 339**

(73) Proprietor: **HUTCHINSON TECHNOLOGY, INC.**  
**Hutchinson,**  
**Minnesota 55350-9784 (US)**

(72) Inventors:  
 • **Ortner, Joseph, P.**  
**Hutchinson**  
**MN 55350 (US)**  
 • **Scheele, Brian, J.**  
**Hutchinson**  
**MN 55350 (US)**

(74) Representative: **Brown, Fraser Gregory James et al**  
**Cleveland**  
**10 Fetter Lane**  
**London EC4A 1BR (GB)**

(56) References cited:

**EP-A- 0 127 947 EP-A- 0 587 009**  
**WO-A-02/28274 WO-A-03/024303**  
**WO-A1-00/77495 US-A- 5 392 783**  
**US-A- 6 061 584 US-B1- 6 839 579**

- **BRUCE A. CROOKES; STEPHEN M. COHN ET AL.: "Can Near-Infrared Spectroscopy Identify the Severity of Shock in Trauma Patients?", THE JOURNAL OF TRAUMA INJURY, INFECTION, AND CRITICAL CARE, vol. 58, no. 4, April 2005 (2005-04), pages 806-816, XP009073413,**
- **BRUCE A. MCKINLEY, PHD; ROBERT G. MARVIN, MD; CHRISTINE S. COCANOUR, MD; FREDERICK A. MOORE, MD: "Tissue Hemoglobin O2 Saturation during Resuscitation of Traumatic Shock Monitored Using Near Infrared Spectrometry.", THE JOURNAL OF TRAUMA INJURY, INFECTION, AND CRITICAL CARE, vol. 48, no. 4, April 2000 (2000-04), pages 637-642, XP009073412,**
- **TALPAHEWA S P ET AL: "Effect of cardiopulmonary bypass on cortical cerebral oxygenation during coronary artery bypass grafting", EUROPEAN JOURNAL OF CARDIO-THORACIC SURGERY, SPRINGER VERLAG, BERLIN, DE, vol. 26, no. 4, 1 October 2004 (2004-10-01), pages 676-681, XP004576428, ISSN: 1010-7940, DOI: 10.1016/J.EJCTS.2004.06.002**

Note: Within nine months of the publication of the mention of the grant of the European patent in the European Patent Bulletin, any person may give notice to the European Patent Office of opposition to that patent, in accordance with the Implementing Regulations. Notice of opposition shall not be deemed to have been filed until the opposition fee has been paid. (Art. 99(1) European Patent Convention).

**EP 2 286 722 B1**

**Description**Background of the Invention

5 **[0001]** The present invention relates to the field of medical spectroscopy and more specifically to the field of mounting sensors on a patient for use in spectroscopy.

**[0002]** The use of spectroscopy in medical condition diagnosis has become commonplace. Typically, light is placed on the surface of tissue in one location and transmitted or scattered light is collected from the tissue in another location. A spectral analysis of the collected light is then performed and the results are compared to stored information about spectral profiles of tissue having known conditions. From this comparison, the condition of the tissue under study may be determined.

10 **[0003]** The light to be transmitted into the tissue is typically placed on the tissue through use of an optical head. The same optical head may be used to collect the light. Some spectroscopy systems allow for collection of light that passes through tissue and therefore one optical head is used for light transmission while a second optical head is used for collection.

15 **[0004]** The optical head may be held directly on the tissue by a doctor, nurse or technician, it may be directly taped or strapped into place, an external structure may hold it in place or it may be held securely in place through a patient interface. A patient interface is a specially designed structure that will typically hold the optical head within its structure and includes an adhesive, suction, compressive, strapping, or other (e.g. glove like) structures to hold the patient interface securely to the patient's tissue. Some examples of patient interfaces are shown in US Pat. Nos. 4,223,680, 4,537,197, 20 4,653,498 (the "New" patent), 4,817,623, 4,825,879 (the "Tan" patent), 4,830,014 (the "Goodman" patent), 4,865,038 (the "Rich" patent), 4,964,408 (the "Hink" patent), 5,094,240, 5,111,817 (the "Clark" patent), 5,224,478, 5,267,563, 5,402,777, 5,584,296, 5,879,373 and 6,381,489.

25 **[0005]** The document WO 02/28274 describes a pulse oximeter sensor that uses multiple photo detectors to detect a red wavelength and two infrared wavelengths. Correction of errors is permitted by monitoring the ratios formed by the signals in different wavelengths.

**[0006]** The document EP 0587009 describes an alignment guide system for use with a pulse oximetry monitor. D5 describes an alarm that can be used to indicate sub-optimal coupling between LEDs and a light detector.

30 **[0007]** Talpahewa, S. P. et al., "Effect of cardiopulmonary bypass on cortical cerebral oxygenation during coronary artery bypass grafting", European Journal of Cardio-Thoracic Surgery, vol. 26, no. 4, 1st October 2004, pages 676-681, discloses (page 677, section 2.5; fig. 1, Section 2.7) a method of locating a patient interface for a tissue measurement instrument on a patient, said instrument comprising a spectrometer, the patient interface having a measurement side for light transmission and light reception; wherein the THI value is measured, wherein the THI value is a measure of the volume percentage of hemoglobin in tissue; and affixing the patient interface to the chosen location.

35 **[0008]** Document WO0077495 A1 discloses the use of a threshold in the THI for the assessment as to whether the position for a measurement is acceptable (page 4, 2nd paragraph).

**[0009]** Document WO0178587 A2 (fig. 3(c)) shows spectroscopy signals at four different locations on the skin; and discloses the preamble of claim 1.

40 **[0010]** It has been found that performing blood spectroscopy on the fingers allows for access to a significant quantity of blood vessels that are near the surface of the skin. Accordingly, a number of patents have been directed to such patient interfaces mountable on a finger, such as the New, Tan, Goodman, Rich, Hink and Clark patents.

**[0011]** A problem with spectroscopy of fingers is that the patient interfaces or the attachment straps tend to wrap entirely around the finger. Blood flow to the finger can be thereby restricted and this can affect the accuracy of the spectroscopy.

45 **[0012]** Further, some locations on the body present more blood vessels near the surface than others. Even within a short range of a location that provides a reasonable level of blood vessels for measurement, a better location may exist. However, the prior art suffers from an inability to relocate the sensor easily once the sensor has been affixed to the tissue.

Summary of the Invention

50 **[0013]** The present invention provides a method of locating a patient interface on a patient, as set forth in the claims hereinafter. In one aspect, a device and process may be provided for assisting in locating a fixture for measurement of an attribute of tissue, such as the percentage of oxygenated hemoglobin present in the tissue. A fixture for holding a light source and a light path to a sensor or the sensor itself may include a base approximately shaped to a thenar muscle of a hand, the base including a passage for light transmission and collection therethrough. A first wing portion may be connected to the base. The first wing portion may be partially wrapped around a body part when the fixture is in use. A second wing portion connected to the base whereby the second wing portion may be partially wrapped around the body part in an opposite direction from the first wing may also be included. The fixture may also include a concave region

formed between the two wings for providing a locating feature for the fixture.

5 [0014] A patient interface for a tissue measurement instrument may include an elongated, flexible base member having a first rounded end and a second rounded end. The base member may have a passage for light transmission therethrough. A first wing may extend from the second end for partially wrapping around a body part to which the interface will be attached. The patient interface may include first and second ends that are convex rounded ends. The patient interface may further include a second wing extending from the second end and first and second convex regions extending from the first end. Alternatively, the first end of the patient interface may have a convex rounded end while the second end is a concave rounded end. In still another alternative, the patient interface has a second wing extending from the second end.

10 [0015] In yet still another alternative embodiment, the base member may include first and second holes allowing for light transmission therethrough. A light source may be provided for providing light to pass through the first hole while a light path (such as an optical fiber) is aligned with the second hole for collecting light that has passed through tissue and adapted to transmit a signal representative of the collected light.

15 [0016] In still another embodiment, the patient interface may have a longitudinal axis between the first rounded end and the second rounded end and the first and second holes lie substantially on the longitudinal axis.

20 [0017] The patient interface may have a top and bottom side. In an embodiment, the bottom side may be adapted to be placed in contact with the patient, and an adhesive may be located on the bottom side while a first liner is used to cover the adhesive. In a variant to this embodiment, a second liner may be used in conjunction with the first liner. The first liner then covers a first portion of the adhesive while the second liner covers another portion of the adhesive. In yet another embodiment of the patient interface, a structure for aiding in the measurement of an attribute of tissue includes a base having a concave locating feature and a longitudinal axis that substantially bisects the locating feature and send and receive fibers each having ends, the ends lying in a line generally along the longitudinal axis and being substantially coplanar when in use.

25 [0018] Another embodiment includes a base having a concave locating feature and a longitudinal axis that substantially bisects the locating feature and send and received light ports generally along the longitudinal axis, the send and receive light ports being substantially coplanar when in use.

[0019] One more embodiment contains a base having a concave locating feature and a longitudinal axis that substantially bisects the locating feature and an elongated opening lying generally along the longitudinal axis, the elongated opening lying generally in a plane when in use.

30 [0020] The invention is a method of locating a patient interface for a tissue measurement instrument on a patient. The patient interface has a measurement side with a light transmission hole and a light receipt hole. The process includes the steps of moving the patient interface around on the tissue in a particular region of the body, while monitoring the output of the spectrometer, until a local maximum THI value is found, wherein the THI value is a measure of the volume percentage of hemoglobin in tissue, and upon finding a location where the local maximum THI value is found, affixing the patient interface to that location. The process may also include the steps of generally aligning the light transmission hole and the light receipt hole along one of a adductor pollicus, a thenar eminence, a hypo thenar eminence, a digit, a first dorsal interosseous or a deltoid muscle.

35 [0021] In an alternative process for attaching the patient interface to a patient, for locating a tissue measurement instrument on a patient the process includes moving the patient interface around on the tissue in a particular region of the body until a location where a desired threshold reading is achieved on the tissue measurement instrument is found. Then, upon finding the location where a desired threshold reading is achieved, the patient interface is firmly held to the patient. Then, the patient interface is partially removed from the patient while holding it in place so that a first amount of adhesive on the measurement side of the patient interface may be readied for attachment to the patient. Next, the first amount of exposed adhesive is placed on the patient. Then, the patient interface is partially removed in a second direction so that a second amount of adhesive may be readied for attachment to the patient. Finally, the second amount of exposed adhesive is placed on the patient. In additional steps to this process, the first amount of adhesive is activated by removing one of the first and second liners; and the second amount of adhesive is activated by removing the other of the first and second liners.

40 [0022] In still another embodiment, a method of locating a patient interface for a tissue measurement instrument is described. The patient interface includes an elongated, flexible base member having a first rounded end, the base member having a passage for light transmission therethrough and at least first and second wings extending from the first end each for partially wrapping around a body part to which the interface will be attached wherein the first end is a concave end. The method of placement includes locating the concave end generally transverse the shoulder axially aligned with the deltoid. The patient interface is then affixed to the patient.

45 [0023] In further steps to this process, the patient interface can include an adhesive on a patient facing surface and a split liner can be used to cover the adhesive until the patient interface is to be affixed to the patient. The process then includes the further steps of lifting a first portion of the patient interface from the patient; removing a first piece of the split liner, placing the first portion of the patient interface back on the patient, lifting a second portion of the patient

interface from the patient, removing a second piece of the split liner, and placing the second portion of the patient interface back on the patient.

[0024] There is yet one more process for locating the patient interface on a patient, where the patient interface has a generally concave locating edge and a measurement side with a light transmission hole and a light receiving hole aligned generally along an axis bisecting the concave locating edge. The process includes the steps of locating the concave locating edge proximate the base of a digit and aligning the light transmission hole and the light receiving hole along a major muscle group to be measured.

[0025] Yet another structure for aiding in the measurement of an attribute of tissue includes a base having a patient side and an adhesive on the patient side, the adhesive having at least first and second adhesive regions. A split liner having first and second portions covers the first and second adhesive regions respectively. The first portion has a first adhesive facing region attached to the adhesive, a first hinge region, a first patient facing region connected to the first adhesive facing region through the first hinge region and a first tab extending beyond the base. The second portion has a second adhesive facing region attached to the adhesive, a second hinge region, a second patient facing region connected to the second adhesive facing region through the second hinge region and a second tab extending beyond the base. A method of placing such a patient interface includes the steps of placing a base on a patient. The base has a patient side and an adhesive on the patient side. The adhesive has at least first and second adhesive regions. A split liner having first and second portions covers the first and second adhesive regions respectively. The first portion has a first adhesive facing region attached to the adhesive, a first hinge region, a first patient facing region connected to the first adhesive facing region through the first hinge region and a first tab extending beyond the base. The second portion has a second adhesive facing region attached to the adhesive, a second hinge region, a second patient facing region connected to the second adhesive facing region through the second hinge region and a second tab extending beyond the base. The first and second portions meet to form a separation. A user pulls on the first tab in a direction substantially normal to the separation and pulls on the second tab in a direction substantially normal to the separation.

Brief Description of the Drawing

[0026]

Fig. 1 is a perspective view of a patient interface. Fig. 1A is a slice view taken along line 1A-1A of the patient interface shown in Fig. 1. Fig. 1B is a bottom view of the patient interface in Fig. 1. Fig. 1C is a side view of the patient interface of Fig. 1 further including an adhesive layer and a release liner layer.

Fig. 1D is a bottom view of the patient interface of Fig. 1 with a split liner. Fig. 1E is a bottom view of the patient interface with a single piece liner. Fig. 1F is a bottom view of an alternative embodiment of the patient interface with a single elongated hole.

Fig. 2A is a top view of a second embodiment of the patient interface. Fig. 2B is a bottom view of the second embodiment of the patient interface.

Figs. 3A-C are perspective views of a patient interface being placed on a hand.

Figs. 4A-B are a flow charts of two processes for placing the patient interface.

Figs. 5A-D are perspective views of an alternative placement of the patient interface of Figs. 2A-B. Figs. 6A-B show an alternate placement of a patient interface proximal to the adductor pollicis.

Figs. 7A-B are top and bottom views of yet another embodiment of the patient interface.

Figs. 8A-B are top views of two additional interface designs where an optical head may be plugged into the interface.

Figs. 9A-B are a top view of interface locations on the back of the first dorsal interosseous between the finger and thumb and the hypothenar respectively.

Fig. 10 is an elevation view of a patient interface on a patient's deltoid muscle.

Fig. 11A is a bottom perspective view of a patient interface with an alternative liner. Fig. 11B is a top expanded slice view along line 11B-11B.

Detailed Description of the Preferred Embodiment

5 [0027] Referring now to Fig. 1, there is shown a patient interface 10 for use with a tissue spectrometer (not shown). The patient interface includes base 12, wings 13 and 14, convex regions 15A and B, concave region 16, pocket 18 and opening 20. The base 12 may have a semi-circular portion between points A and B and extend in convex regions 15 A and B. The convex regions are intended to engage peripheral portions of the thenar eminence or other sites when positioned for use on the hand. The convex regions are also intended to shield ambient light while engaging the peripheral portions of the thenar eminence. The convex regions 15A and B lead into concave regions 17A and B which are intended to roughly follow the narrowing of the thenar eminence or other sites at its distal end. Wings 13 and 14 are for partially wrapping around the thumb or other sites of the patient. Concave region 16 serves as a locating feature such as at the base of the thumb or other finger or a pediatric shoulder for example. Other locating features such as v shapes or notches are also contemplated. Concave region 16, located between the wings, is intended to engage the patient's thumb approximately at the intersection of the first metacarpal bone (or the other metacarpal bones) with the hand.

10 [0028] Alternatively, the present patient interface can be used for spectroscopy applications on baby or small child in the deltoid region of the child's arm as shown in Fig. 10.

15 [0029] The bottom of the patient interface (Fig. 1B) shows an essentially flat patient surface 22 with holes 23 and 24 therein. Hole 24 is preferably for light transmission into the patient while hole 23 is for collecting light from the patient into a return transmission to the spectrometer. The holes, particularly hole for receiving light is preferably located near the center of the convex region so that additional shielding from ambient light is provided. As can be seen in the slice view Fig. 1A, opening 20 provides a path for fiber optic cable 28 to reach the inside of pocket 18. There, a light transmission fiber 30 is provided with a path to transmit light to the patient. Here, fiber 30 terminates and light exits the fiber and is reflected through hole 24 by mirror 26. Light returning from tissue (not shown) is collected through hole 23 into light return fiber 29 for transmission to the spectrometer for analysis. In one embodiment, the holes 23 and 24 are at least approximately co-axial with an axis 19C extending between a centerpoint 19A of the concave region 16 and a centerpoint 19B of first end 11. In another embodiment, a mirror is positioned inside the opening to reflect light onto a receive fiber. It should be noted that while one preferred embodiment has been described, there are many other possible methods of transmitting light to tissue and collecting and transmitting the return light signal back to the spectrometer.

20 [0030] In an alternative embodiment, a single elongated hole 23 A is used to replace holes 23 and 24. In such an embodiment, an integrated sensor head may be used to hold light transmission and light receiving paths in place and to isolate the light receiving path from the light transmission path. The single elongated hole has the elongation generally aligned with axis 19C.

25 [0031] Referring now to Fig. 1C, there is shown a side view of the patient interface 10 with adhesive 32 and liner 34. In operation it is desirable for the patient interface to adhere to the patient. Adhesive 34 may be an entire layer, a pattern (such as dots of adhesive), lines of adhesive or virtually any other method of distributing adhesive on the patient surface 22. The adhesive itself is generally chosen so that it is compatible with human tissue and does not create a permanent bond. One adhesive that may be used is 3M 1524 adhesive. Other adhesives having hypoallergenic properties would also be acceptable. Alternatively, belts, tape, Velcro® fasteners and gloves as well as other well known attachment methods may be used. The liner 34 covers the adhesive until the patient interface is ready for affixing. It is made of a material that will lightly adhere to the adhesive, but is easy to remove at the point that the patient interface is ready to be used.

30 [0032] As can be seen in Fig. 1D, the liner 34 may be split into two pieces 34A and 34B. This allows for the liner to be removed in two steps without lifting the interface completely off the patient. Other arrangements where something other than an even split between the liner pieces may be used as well. In Fig. 1E, the liner is shown as a single piece 34 that covers the entire patient side of the interface.

35 [0033] Referring now to Figs. 2A-B there is shown top and bottom views of a second embodiment of the patient interface 10A. This patient interface is essentially the same as the patient interface of Fig. 1 except that it includes an additional wing 13A. The reason for the additional wing will become apparent in connection with the discussion of Figs. 5A-D.

40 [0034] The patient interface may be made of a soft polymer material such as Santoprene available from Exxon Mobile Chemicals. Rubber, foam and other soft, pliable materials may also be used. The interfaces may be formed by through injection molding. Alternatively, the patient interface may be formed in an upper and lower piece and ultrasonically welded together.

45 [0035] Switching now to the method of placement of the patient interface, a flowchart of two such methods is shown in Figs. 4A and B. Referring now to Fig. 4A, it is desirable to locate the patient interface at a location having a predetermined tissue hemoglobin index (THI) measurement. This will provide a suitable location from which to measure hemoglobin oxygenation. In one case, a local maximum THI value is sought and the patient interface is moved while the output of the spectrometer is monitored. The user then locates the interface in a position providing a highest reading. In an alternative process, a threshold level of THI is sought by moving the interface. Once the threshold has been found, the

interface is attached to the patient. In one embodiment, the threshold is a two percent tissue hematocrit value.

**[0036]** The process for locating the interface using THI measurements includes starting at block 405, and moving to block 410 where a patient interface, connected to a tissue spectrometer, is put into a first position. Then at block 415, a THI measurement is taken. In block 420, the user determines whether any further locations need to be tested. Such a determination may be made using the above noted minimum threshold THI method or the maximum THI method.

**[0037]** If more THI values are needed, then, the patient interface is moved to a new position in block 425 and a new THI measurement is taken again in block 415. If a new measurement is not needed, then the patient interface can be held in place while the liner is removed and the patient interface is adhered to the patient as specified in block 430. The process would then end at block 440.

**[0038]** Alternatively, a higher localized temperature may also be sensed to provide an indication of the amount of blood flow through a portion of tissue in place of a THI value. In this instance, a temperature sensor would be mounted in the interface and the interface would be moved until a local maximum temperature is found and then the interface would be attached at the location of the local maximum temperature. Other sensors that may indicate a local maximum of blood flow may be used. The key is that it is preferable to place the interface where a local maximum of blood flow may occur and that the sensing method used for placement provide some indication of local blood flow.

**[0039]** Alternatively, the locating feature of the patient interface may be used without a blood flow measurement to aid in placement the patient interface as shown in Fig. 4B. After starting at block 450, the process moves to block 460 where the alignment guide of the patient interface is placed in a desired location (such as the base of a finger). Next, the opposite end of the patient interface is located so that an axis running through the midpoint of the patient locating feature and the opposite end is aligned with a muscle to be monitored as described in block 470. The liner is then removed as in block 480 and the interface is affixed to the patient in 490 before the process ends in block 495.

**[0040]** There are at least three ways of removing the liner as described in block 430. First, a single liner may be used. Once the location having the desired THI value is located, the patient interface may be tilted to one side at the desired location and the single liner removed. The patient interface may then be placed back onto the patient. In the case where a split liner is used, the patient interface may be placed at the location having the desired THI value and the patient interface is partially lifted so that one side of the split liner may be removed. The patient interface is then replaced on the patient so that the adhesive that has been uncovered attaches to the patient. The other side of the patient interface may then be lifted and the liner removed and the lifted portion is again replaced on the patient. Lastly, a "butterfly" liner may be used (as described herein) for removal of the liner without lifting of the patient interface.

**[0041]** THI may be calculated using the process specified in US Pat. No. 6,473,632 ("Myers") commonly assigned with the present patent. By using the combination of both a single term ratio of a second derivative light absorbance value of tissue and a single term non-ratioed second derivative light absorbance value of the tissue, measure of the volume percentage of a chromophore such as hemoglobin in tissue (a value that directly correlates with hemoglobin concentration) can be calculated (the above noted THI).

**[0042]** In one configuration the wavelength gap used to calculate the second derivative values (i.e., the interval between adjacent absorbance wavelengths used in the second derivative calculation) is 40 nm. At this gap size only four wavelengths are used to calculate both the percentage of oxidized hemoglobin and the THI. The second derivative absorbance peak at 720 nm (deoxyhemoglobin absorption band of 760 nm) is used to empirically derive the relationship between THI and second derivative absorbance. Second derivative gap sizes other than 40 nm can also be used to derive the hematocrit algorithm. Also, other wavelength regions (e.g., visible or infrared) corresponding to other oxyhemoglobin or deoxyhemoglobin absorbance maximums could be used.

**[0043]** The THI measurements made in accordance with the algorithms described herein can be used by an instrument in connection with tissue recognition algorithms. Inaccurate and/or invalid measurements of %StO<sub>2</sub> or other measured parameters can be displayed by the instrument monitor if the probe is not properly located on the tissue to be measured. The THI can be used by the instrument to determine whether the probe is properly positioned and the measurement is accurate. For example, in connection with some or all of the parameter measurements, the instrument can compute the THI using the algorithm described herein, and display the parameter measurement as an accurate measurement only if the THI is representative of a predetermined minimum level. If the THI is below the predetermined level, the monitor can generate a display indicating that the probe is not properly positioned.

**[0044]** THI measurements can be generated as a function of current second derivative spectroscopy values and stored data describing the relationship between the second derivative values and the tissue hemoglobin concentration, hi the embodiment described below, the stored relationship data is data describing a set of lines or slopes (or curves if preferred), each of which is associated with a constant oxidation state of hemoglobin.

**[0045]** During THI, the proper stored relationship data can be selected by the instrument on the basis of the measured hemoglobin oxidation state. From this data and the current second derivative spectroscopy value, the THI can be computed by the instrument.

**[0046]** At multiple levels of hematocrit (HCT), the second derivative spectral features of the blood are recorded at a predetermined (e.g., 5 mm) probe spacing over multiple % StO<sub>2</sub> values within the 0%-100% range. For each hematocrit

the 720 nm second derivative peak is fitted to a linear equation.

[0047] At each constant level of %StO<sub>2</sub>, the second derivative 720 nm feature is related to % hematocrit with extrapolation to 0% hematocrit. There is a linear relationship between the 720 nm second derivative and hematocrit at hematocrits of about 25% and less.

[0048] Using linear extrapolation to 0% hematocrit and empirical measurements at 25% and 15% hematocrit, a lookup table of relationship data which describes the sensitivity of hematocrit to the 720 nm second derivative values (lines of constant %StO<sub>2</sub>) can be created. The slopes are functionally related to the ratio of the second derivative at 680 nm to the second derivative at 720 nm.

[0049] The stored relationship data described above is subsequently used during tissue hemoglobin concentration measurements. Upon measuring %StO<sub>2</sub> (e.g., using conventional algorithms and scaled second derivative values at 680 nm) the corresponding slope value (Mso<sub>2</sub> or HCT slope) is found within the lookup table. The predicted hematocrit value is then:

$$\%HCT=(Mso_2) \times (D720/PSF)$$

Where: D720 is the second derivative at 720 nm using the 40 nm gap PSF is the relative path length change due to probe spacing.

[0050] The concentration of tissue hematocrit is generally less than 25%, and is usually in the 1%-10% range. When evaluating probe position on the basis of hemoglobin concentration measurements, relatively high measurement accuracy near the lower end of the range is sufficient. For example, the threshold for determining whether the probe is on or off tissue can be in the range of 1% measured hemoglobin concentration. The linear range of spectral features versus hematocrit concentration need only be used for this application. However, the measurement accuracy can be extended to greater percentages of hematocrit by redefining the algorithm to account for nonlinearities. The algorithm could, for example, be redefined as a multiple regression algorithm consisting of multiple slope and second derivative transformations (linear transformations). Examples of nonlinear equations include:

$$\%HCT=(Mso_{2i}) \times (D720/PSF)+(Mso_{2_2}) \times \text{Log}(D720/PSF)$$

or

$$\%HCT=(Mso_{2_1}) \times (D720/PSF) + (Mso_{2_2}) \times (D720/PSF)^{1/2} + (Mso_{2_3}) \times (D720/PSF)^{1/3} + \dots$$

Where: Mso<sub>2i</sub>, Mso<sub>2<sub>2</sub></sub>, ... are nonlinear slope value coefficients which can be stored in the lookup table.

[0051] The probe scaling factor (PSF) can be empirically determined by collecting second derivative spectral measurements of a chromophore medium, preferably having constant scattering and absorption properties, with optical probes having variable distances between the optical send and receive fibers. The spectral measurements at each probe spacing are then referenced (ratioed) to one of the fixed probe spacing spectral measurements at a particular wavelength of interest. The ratio of one second derivative spectrum value at a probe spacing of interest to the second derivative spectrum value of the reference probe spacing then reflects the probe scaling factor. The probe scaling factor can be determined at calibration stored in memory.

[0052] Referring now to Figs. 3A-C, there is shown a patient interface as used in the process of Figs. 4A-B. In Fig. 3A, the patient interface 15 is shown in a first position X such that concave region 16 would lie proximal to the thumb by some amount. Note that wings 13 and 14 are not permanently set around the thumb at this point. A significant portion of the base 12 would cover the thenar eminence 315. A THI measurement would be made at this location. Then, the patient interface may be moved, for example, to the location indicated as Y in Fig. 3B. Here, not only is the concave region 16 over the thumb, so is a portion of the base 12. Little of the base 12 is covering the thenar eminence 315. Another THI measurement would be made here. Then, if the THI measurement at location Y is more desirable the THI measurement at location X, the value at position Y would be stored or otherwise noted (or if this was deemed to be a final test location, the patient interface 10 could be fixed at this location). In our case, we wish to try one more location.

[0053] As shown in Fig. 3C, a location Z between locations X and Y is then selected. Here, if a desired THI value is found (we will assume it is) it replaces the previous THI value and if this is the final location to be tested (we will again

assume that it is) the patient interface may then be removably affixed to the patient by, for example, removal of the liner (not shown in this figure) and placement of the adhesive onto the tissue. Note that wings 13 and 14 are wrapped partly around the thumb, a particularly preferred embodiment, the wings are not long enough to wrap entirely around the thumb.

**[0054]** Referring now to Figs. 5A-D the shown are alternate locations for the patient interface shown in Figs. 2A-B.

The process followed to place the patient interface here may parallel the process specified in Figs. 4A-B. In Figs. 5A-B, the measurement site selected is the first dorsal interosseous. The concave region 16 is located at a side of the index finger distal to the junction of the finger with the hand. The first wing 13 and additional wing 13A are wrapped around between the index finger and thumb on the back side of the hand while the second wing 14 is wrapped around between the index finger and the middle finger on the back side of the hand (see particularly Fig. 5B). The second wing is particularly useful in maintaining a stable attachment to the hand in this location. In Fig. 5C, the concave region 16 is located at the junction of the finger with the hand. Wings 13 and 13 A extend between the index finger and the thumb onto the palm as shown in Fig. 5D. Wing 14 may preferably extend in the direction of the middle finger, or wrap around between the index and middle finger.

**[0055]** Referring now to Figs. 7A-B, the shown are top and bottom views of yet another embodiment of the patient interface of the present disclosure. The patient interface 100 includes base 12, wings 13 and 14, convex regions 15A and B, concave region 16, pocket 18 and opening 20. Here, unlike the patient interface of Fig. 1, the base 12 does not have a semi-circular portion between convex regions 15A and 15B.

**[0056]** Instead, the convex regions are formed similar to the wings 13 and 14. The convex regions 15A and B lead into concave regions 17A and B. By having the separate convex regions and wings, this embodiment of the patient interface is well adapted to mounting on a location where the diameter of the body part on which the patient interface may change from one end of the patient interface to the other. In particular, this interface may be used for measurement of an adult deltoid muscle. Wings 13 and 14 are well adapted to partially wrap around the arm. Concave region 16 serves as a locating feature such as at the junction of the arm with the shoulder. Other locating features such as v shapes or notches are also contemplated.

**[0057]** Fig. 6A shows yet another placement of the patient interface of Fig. 1. Here, the patient interface is placed along an axis under which the adductor pollicis muscle runs. The patient interface 10 is placed in a location such that one wing contacts the junction of the thumb with the hand while the other wing contacts the junction of the forefinger with the hand. Fig. 6B shows placement of the patient interface of Figs. 7A-B along the adductor pollicis muscle. For both Figs. 6A-B, the base of the patient interface is then placed so that the holes 23 and 24 are aligned along the adductor pollicis muscle.

**[0058]** A common theme among all of the placements is a desire to align the holes 23 and 24 along a longitudinal axis of the muscle. This is a primary reason for having the concave region and wings as shown. This alignment produces a significant signal path for the light to transverse through perfused tissue. Each finger has a muscle known as the lumbrical muscles running axially from the heel of the hand to the junction of the finger with the palm. Each such muscle presents an acceptable site along which the patient interface may be placed. The wings may be extended around the side of a finger with the opposite end of the patient interface (particularly where the opening 20 is located) being positioned generally in alignment with the finger around which the wings have been placed.

**[0059]** Referring now to Figs. 8A-B, the shown are two additional interface designs. In Fig. 8A, an interface 10 similar to the interface of Fig. 1 is shown. Here, however, an optical head may be inserted into opening 200 so that the interface may be left in place at a desired location while allowing for the option of removal of the spectrometer if so desired. An alternative design is shown in Fig. 8B.

**[0060]** Referring now to Figs. 9A-B, the shown are other alternative locations for an interface on a hand. Two preferred locations include the back of the hand on the webspace between the thumb and forefinger (the first dorsal interosseous) (Fig. 9A) and on the hypothenar muscle (Fig. 9B).

**[0061]** In Figs. 11A and B, the shown is a "butterfly" version of the liner on the patient interface 10. The base 12 of the patient interface may be formed with a central opening 200 therein. An adhesive (not shown) may be placed on a patient facing portion of the patient interface to facilitate mounting the patient interface on the patient. Split liner 34 may be placed on the adhesive to prevent the patient interface from attaching to anything other than the patient. As can be seen more particularly in Fig. 11B, the split liner may be a folded or hinged, at 34C and D, piece of material that includes a patient side 34A and B and an adhesive side 34AA and BB. To use an interface having the butterfly version of the liner, the interface is lightly placed on the patient at a desired location. While holding the interface in place, tabs 35A and B are then pulled, in a direction normal to axis 19A-B and substantially coplanar with the plane in which sides 34A and B reside. The liner 34 will then move as indicated by arrows X and Y such that adhesive on the interface is then exposed and placed in contact with the patient as the liner is removed.

Claims

1. A method of locating a patient interface (10) for a tissue measurement instrument on a patient, said instrument comprising a spectrometer, the patient interface having a measurement side with a light transmission hole (24) and a light receipt hole (23); **characterised by** comprising the step of:
  - moving the patient interface around on the tissue in a particular region of the body, while monitoring the output of the spectrometer, until a local maximum THI value is found;
  - wherein the THI value is a measure of the volume percentage of hemoglobin in tissue; and
  - upon finding a location where the local maximum THI value is found, affixing the patient interface to that location.
2. The method of claim 1, further including aligning the light transmission hole and the light receipt hole along one of a adductor pollicus, a thenar eminence, a hypo thenar eminence, a digit, a first dorsal interosseous or a deltoid muscle.
3. The method of claim 1 or 2, wherein the patient interface has a base member defining the measurement side and each hole, the patient interface having an adhesive disposed on the measurement side, the adhesive having at least first and second adhesive regions, the patient interface further having first and second portions covering the first and second adhesive regions respectively, the first portion having a first adhesive facing region attached to the adhesive, a first hinge region and a first patient facing region connected to the first adhesive facing region through the first hinge region, the second portion having a second adhesive facing region attached to the adhesive, a second hinge region and a second patient facing region connected to the second adhesive facing region through the second hinge region, the first and second portions meeting to form a separation, the method further including the steps of:
  - pulling on the first patient facing region in a direction substantially normal to the separation; and
  - pulling on the second patient facing region in a direction substantially normal to the separation, wherein the first patient facing region has a first tab extending beyond the base member and the second patient facing region has a second tab extending beyond the base member, wherein the step of pulling on the first patient facing region includes pulling on the first tab and the step of pulling on the second patient facing region includes pulling on the second tab.
4. The method of any of claims 1 to 3, wherein the patient interface includes an elongated, flexible base member having a first rounded end and a second rounded end, the base member having a passage for light transmission therethrough, and at least first and second wings extending from the first end each for partially wrapping around a body part.
5. The method of claim 4, wherein the base member further includes a third wing for partially wrapping around a body part.
6. The method of claim 4 or claim 5, wherein the patient interface includes a base member having a concave locating feature and a longitudinal axis that bisects, or substantially bisects, the locating feature, the method further including the steps of:
  - locating the concave locating feature proximate the base of a digit of the patient; and
  - aligning the light transmission hole and the light receiving hole along a major muscle group to be measured.
7. The method of claim 6, wherein the major muscle group includes one of an adductor pollicus, a thenar eminence, a hypo thenar eminence, a first dorsal interosseous or a deltoid muscle.
8. The method of claim 6, wherein the concave locating feature is disposed between the first and second wings.
9. The method of claim 6, further including the steps of:
  - locating the concave locating feature transverse a shoulder axially aligned with a deltoid of the patient; and
  - affixing the patient interface to the patient.
10. The method of any of claims 1 to 9, wherein the patient interface includes an adhesive on a patient facing surface and a split liner is used to cover the adhesive until the patient interface is to be affixed to the patient, the method further including the steps of:

lifting a first portion of the patient interface from the patient;  
removing a first piece of the split liner;  
placing the first portion of the patient interface back on the patient;  
lifting a second portion of the patient interface from the patient;  
5 removing a second piece of the split liner; and  
placing the second portion of the patient interface back on the patient.

## Patentansprüche

- 10
1. Verfahren zum Ansetzen einer Patientenschnittstelle (10) für ein Gewebemessinstrument auf einem Patienten, wobei das Instrument ein Spektrometer umfasst, die Patientenschnittstelle eine Messseite mit einer Öffnung für die Lichttransmission (24) und einer Öffnung für den Empfang des Lichts (23) aufweist, **dadurch gekennzeichnet, dass** es die folgenden Schritte umfasst:

15

Bewegen der Patientenschnittstelle um das Gewebe in einem bestimmten Bereich des Körpers, während die Datenausgabe des Spektrometers überwacht wird, bis ein lokaler maximaler THI-Wert gefunden wird; wobei der THI-Wert eine Messung aus dem Volumenprozentsatz des Hämoglobins in dem Gewebe ist; und nach Auffinden der Stelle, an der der lokale maximale THI-Wert gemessen wurde, Befestigen der Patientenschnittstelle an dieser Stelle.

- 20
2. Verfahren nach Anspruch 1, ferner das Ausrichten der Öffnung für die Lichttransmission und der Öffnung für den Empfang des Lichts entlang des Daumenadduktors, des Daumenballens, des Hypothenars, eines Fingers, des Musculus interosseus dorsalis I oder des Deltamuskels einschließend.

- 25
3. Verfahren nach Anspruch 1 oder 2, wobei die Patientenschnittstelle ein Grundelement aufweist, das die Messseite und jede Öffnung definiert, wobei die Patientenschnittstelle ein Haftmittel aufweist, das an der Messseite angeordnet ist, wobei das Haftmittel wenigstens erste und zweite Haftbereiche aufweist, die Patientenschnittstelle ferner erste und zweite Anteile aufweist, die die ersten beziehungsweise zweiten Haftbereiche abdecken, wobei der erste Anteil einen ersten dem Haftmittel zugewandten Bereich aufweist, der an das Haftmittel angeheftet ist, einen ersten Gelenkbereich und einen ersten dem Patienten zugewandten Bereich, der mit dem ersten dem Haftmittel zugewandten Bereich durch den ersten Gelenkbereich verbunden ist, wobei der zweite Anteil einen zweiten dem Haftmittel zugewandten Bereich aufweist, der an das Haftmittel angeheftet ist, einen zweiten Gelenkbereich und einen zweiten dem Patienten zugewandten Bereich, der mit dem zweiten dem Haftmittel zugewandten Bereich durch den zweiten Gelenkbereich verbunden ist, wobei die ersten und zweiten Anteile aneinanderstoßen, um eine Abtrennung zu bilden, wobei das Verfahren ferner die folgenden Schritte einschließt:

30

Ziehen an dem ersten dem Patienten zugewandten Bereich in einer im Wesentlichen zu der Abtrennung normalen Richtung; und

40

Ziehen an dem zweiten dem Patienten zugewandten Bereich in einer im Wesentlichen zu der Abtrennung normalen Richtung, wobei der erste dem Patienten zugewandte Bereich einen ersten Streifen aufweist, der sich über dem Grundelement erstreckt, und der zweite dem Patienten zugewandte Bereich einen zweiten Streifen aufweist, der sich über dem Grundelement erstreckt,

45

wobei der Schritt des Ziehens an dem ersten dem Patienten zugewandten Bereich das Ziehen an dem ersten Streifen einschließt und der Schritt des Ziehens an dem zweiten dem Patienten zugewandten Bereich das Ziehen an dem zweiten Streifen einschließt.

- 50
4. Verfahren nach einem der Ansprüche 1 bis 3, wobei die Patientenschnittstelle ein längliches, elastisches Grundelement einschließt, das ein erstes abgerundetes Ende und ein zweites abgerundetes Ende aufweist, wobei das Grundelement einen Durchgang für die Lichttransmission durch es hindurch aufweist, und wenigstens erste und zweite Flügel, die sich von dem ersten Ende erstrecken und jeweils dazu dienen teilweise um ein Körperteil gewickelt zu werden.

- 55
5. Verfahren nach Anspruch 4, wobei das Grundelement ferner einen dritten Flügel aufweist, der dazu dient teilweise um ein Körperteil gewickelt zu werden.

6. Verfahren nach Anspruch 4 oder 5, wobei die Patientenschnittstelle ein Grundelement mit einem konkaven Merkmal zum Ansetzen und einer longitudinalen Achse, die das Merkmal zum Ansetzen teilt oder im Wesentlichen teilt,

## EP 2 286 722 B1

einschließt, wobei das Verfahren ferner folgende Schritte einschließt:

Ansetzen des Merkmals zum Ansetzen unmittelbar an der Basis eines Fingers des Patienten; und  
Ausrichten der Öffnung für die Lichttransmission und der Öffnung zum Empfang des Lichts entlang einer Haupt-  
muskelgruppe, die gemessen werden soll.

7. Verfahren nach Anspruch 6, wobei die Hauptmuskelgruppe den Daumenadduktor, den Daumenballen, den Hypo-  
thenar, den Musculus interosseus dorsalis I oder den Deltamuskel einschließt.

8. Verfahren nach Anspruch 6, wobei das konkave Merkmal zum Ansetzen zwischen den ersten und zweiten Flügeln  
angeordnet ist.

9. Verfahren nach Anspruch 6, ferner folgende Schritte umfassend:

Ansetzen des konkaven Merkmals zum Ansetzen quer zu einer Schulter axial mit dem Deltamuskel des Patienten  
ausgerichtet; und  
Befestigen der Patientenschnittstelle an dem Patienten.

10. Verfahren nach einem der Ansprüche 1 bis 9, wobei die Patientenschnittstelle ein Haftmittel auf der dem Patienten  
zugewandten Seite einschließt, und ein Abdeckbogen verwendet wird, um das Haftmittel abzudecken, bis die Pa-  
tientenschnittstelle an dem Patienten befestigt wird, wobei das Verfahren ferner die folgenden Schritte umfasst:

Abheben des ersten Anteils der Patientenschnittstelle von dem Patienten;  
Entfernen des ersten Stücks des Abdeckbogens;  
wieder Platzieren des ersten Anteils der Patientenschnittstelle auf dem Patienten;  
Abheben des zweiten Anteils der Patientenschnittstelle von dem Patienten;  
Entfernen des zweiten Stücks des Abdeckbogens; und  
wieder Platzieren des zweiten Anteils der Patientenschnittstelle auf dem Patienten.

### Revendications

1. Procédé de localisation d'une interface patient (10) pour un instrument de mesure de tissu sur un patient, ledit  
instrument comprenant un spectromètre, l'interface patient ayant un côté de mesure avec un trou de transmission  
de lumière (24) et un trou de réception de lumière (23) ; **caractérisé en ce qu'il** comprend les étapes consistant à :

déplacer l'interface patient autour du tissu dans une zone particulière du corps, tout en surveillant la sortie du  
spectromètre, jusqu'à ce qu'une valeur locale maximale TH1 soit trouvée ;  
dans lequel la valeur TH1 est une mesure du pourcentage en volume d'hémoglobine dans le tissu ; et  
lors de la découverte d'un emplacement où la valeur locale maximale TH1 est détectée, fixer l'interface patient  
à cet emplacement.

2. Procédé selon la revendication 1, comprenant en outre l'alignement du trou de transmission de lumière et du trou  
de réception de lumière le long d'un parmi un adducteur du pouce, une éminence thénar, une éminence hypothénar,  
un doigt, un premier interosseux dorsal ou un muscle deltoïde.

3. Procédé selon la revendication 1 ou 2, dans lequel l'interface patient comporte un élément de base définissant le  
côté de mesure et chaque trou, l'interface patient ayant un adhésif disposé sur le côté de mesure, l'adhésif ayant  
au moins des première et seconde zones adhésives, l'interface patient ayant en outre des première et seconde  
parties recouvrant respectivement les première et seconde zones adhésives, la première partie comportant une  
première zone faisant face à l'adhésif attachée à l'adhésif, une première zone d'articulation et une première zone  
faisant face au patient reliée à la première zone faisant face à l'adhésif par l'intermédiaire de la première zone  
d'articulation, la seconde partie ayant une seconde zone faisant face à l'adhésif attachée à l'adhésif, une seconde  
zone d'articulation et une seconde zone faisant face au patient reliée à la seconde zone faisant face à l'adhésif par  
l'intermédiaire de la seconde zone d'articulation, les première et seconde parties se rencontrant pour former une  
séparation, le procédé comprenant en outre les étapes consistant à :

tirer sur la première zone faisant face au patient dans une direction sensiblement perpendiculaire à la séparation ;

et

tirer sur la seconde zone faisant face au patient dans une direction sensiblement perpendiculaire à la séparation, dans lequel la première zone faisant face au patient a une première patte s'étendant au-delà de l'élément de base, et la seconde zone faisant face au patient a une seconde patte s'étendant au-delà de l'élément de base, dans lequel l'étape consistant à tirer sur la première zone faisant face au patient comprend l'étape consistant à tirer sur la première patte, et l'étape consistant à tirer sur la seconde zone faisant face au patient comprend l'étape consistant à tirer sur la seconde patte.

5

10

4. Procédé selon l'une quelconque des revendications 1 à 3, dans lequel l'interface patient comprend un élément de base allongé souple ayant une première extrémité arrondie et une seconde extrémité arrondie, l'élément de base ayant un passage pour une transmission de lumière à travers celui-ci, et au moins des première et deuxième ailettes s'étendant à partir de la première extrémité, chacune pour s'enrouler partiellement autour d'une partie du corps.

15

5. Procédé selon la revendication 4, dans lequel l'élément de base comprend en outre une troisième ailette destinée à s'enrouler partiellement autour d'une partie du corps.

20

6. Procédé selon la revendication 4 ou la revendication 5, dans lequel l'interface patient comprend un élément de base ayant une caractéristique de localisation concave et un axe longitudinal qui recoupe, ou qui recoupe sensiblement la caractéristique de localisation, le procédé comprenant en outre les étapes consistant à :

localiser la caractéristique de localisation concave à proximité de la base d'un doigt du patient ;

et

aligner le trou de transmission de lumière et le trou de réception de lumière le long d'un groupe de muscles majeurs à mesurer.

25

7. Procédé selon la revendication 6, dans lequel le groupe de muscles majeurs comprend l'un parmi un adducteur du pouce, une éminence thénar, une éminence hypothénar, un doigt, un premier interosseux dorsal ou un muscle deltoïde.

30

8. Procédé selon la revendication 6, dans lequel la caractéristique de localisation concave est disposée entre les première et deuxième ailettes.

9. Procédé selon la revendication 6, comprenant en outre les étapes consistant à :

35

localiser la caractéristique de localisation concave transversale par rapport à une épaule alignée axialement avec un deltoïde du patient ; et

fixer l'interface patient sur le patient.

40

10. Procédé selon l'une quelconque des revendications 1 à 9, dans lequel l'interface patient comprend un adhésif sur une surface faisant face au patient, et une doublure fendue est utilisée pour recouvrir l'adhésif jusqu'à ce que l'interface patient doive être fixée sur le patient, le procédé comprenant en outre les étapes consistant à :

soulever une première partie de l'interface patient à partir du patient ;

enlever une première partie de la doublure fendue ;

45

replacer la première partie de l'interface patient sur le patient ;

soulever une seconde partie de l'interface patient à partir du patient ;

enlever une seconde partie de la doublure fendue ; et

replacer la seconde partie de l'interface patient sur le patient.

50

55

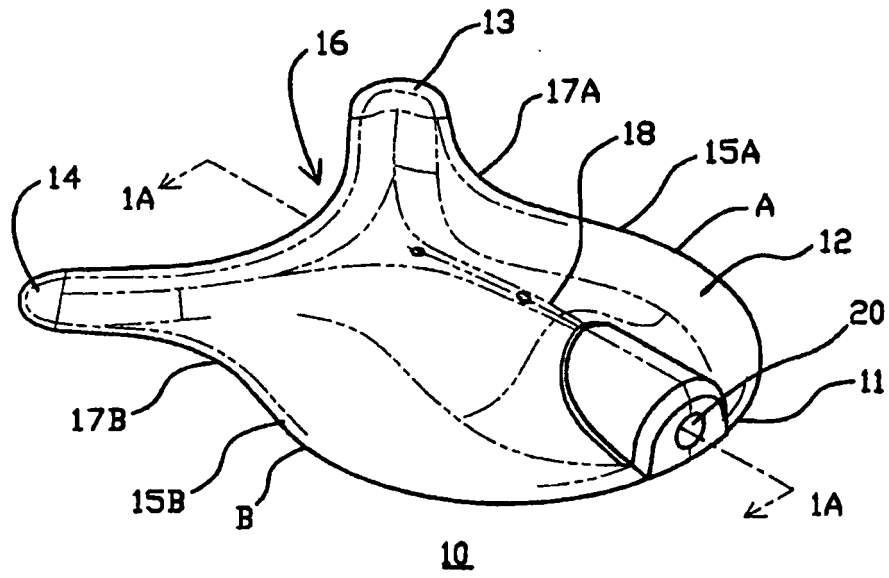

FIG. 1

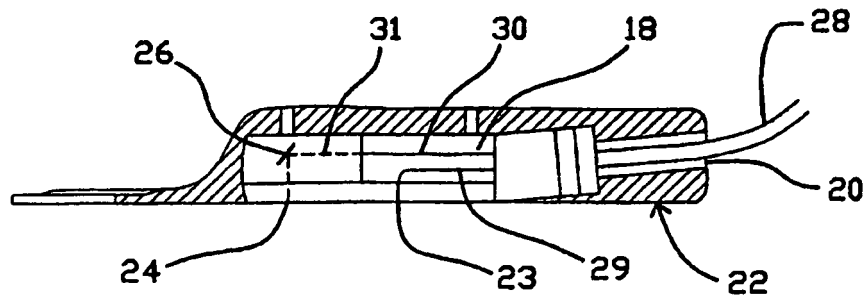

FIG. 1A

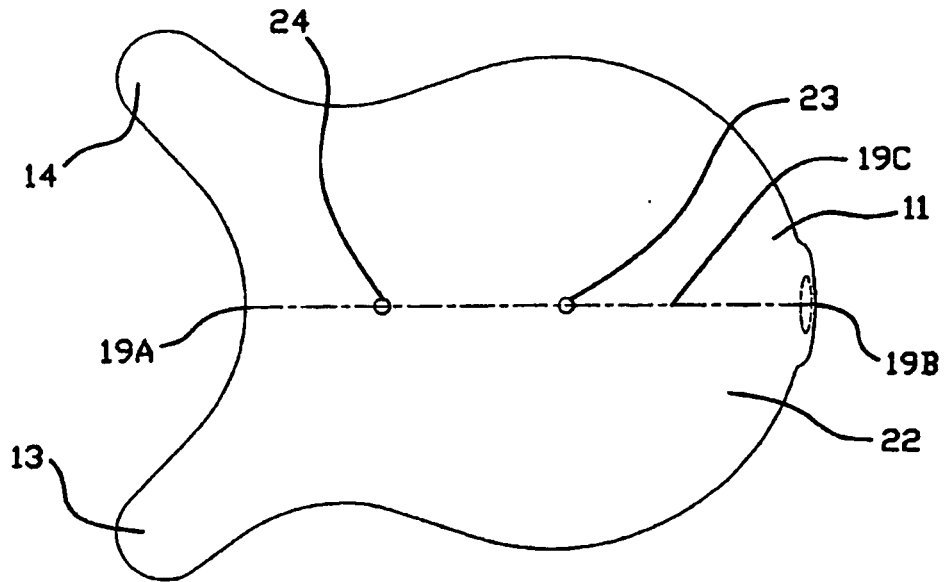

FIG. 1B

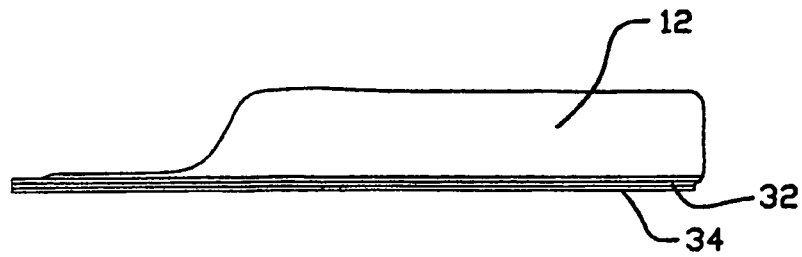

FIG. 1C

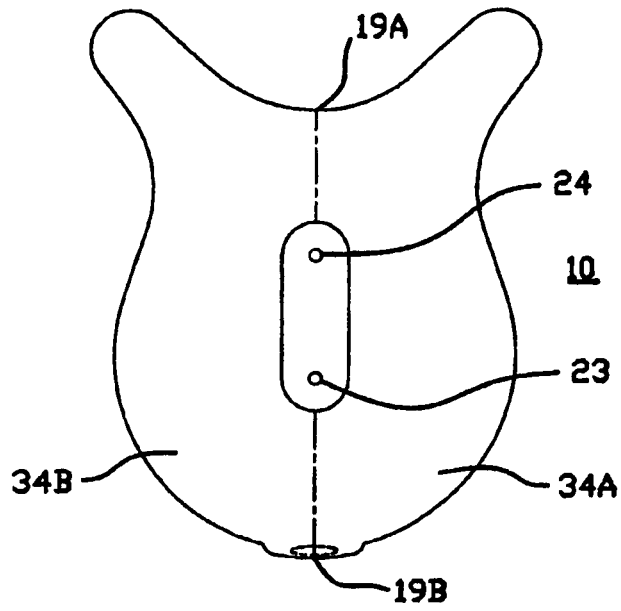

FIG. 1D

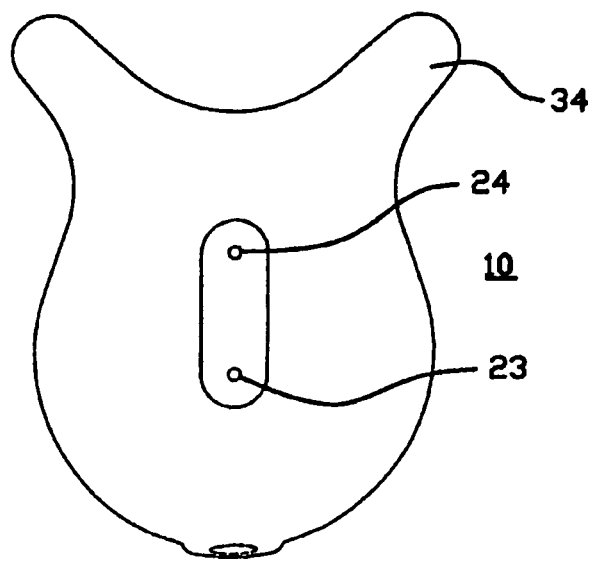

FIG. 1E

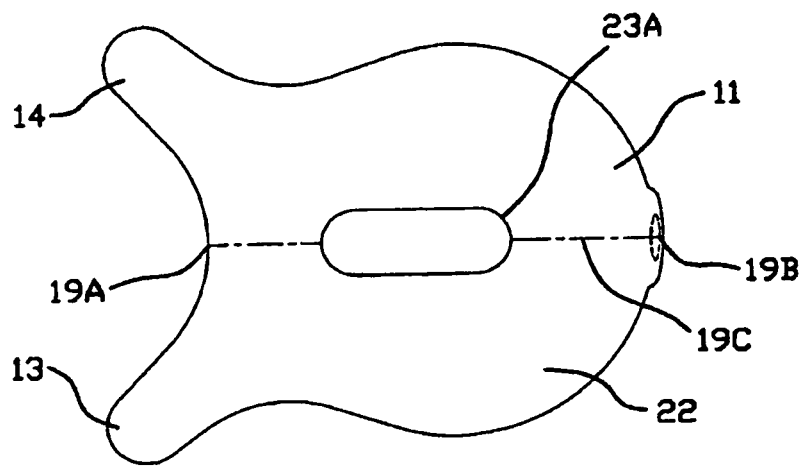

FIG. 1F

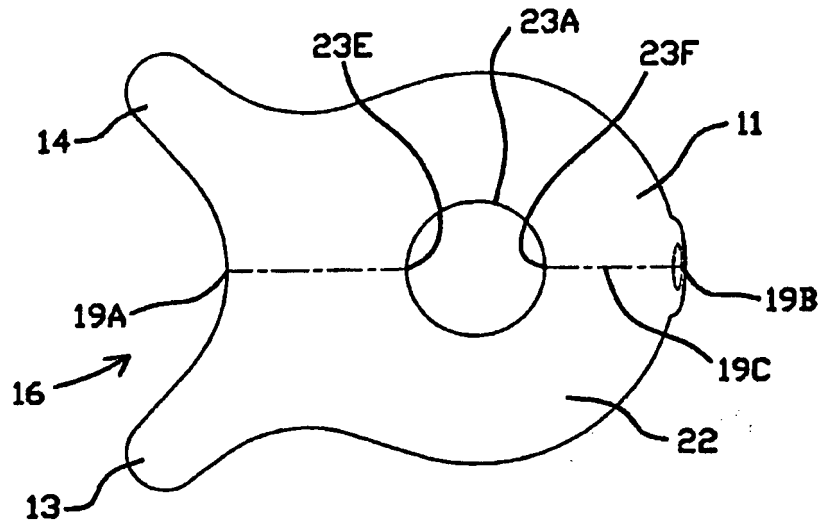
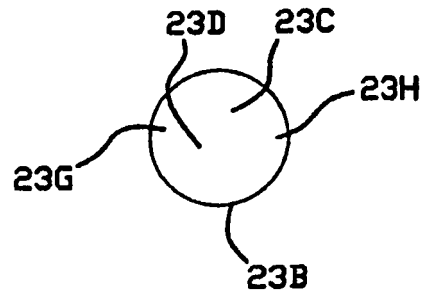

FIG. 1G



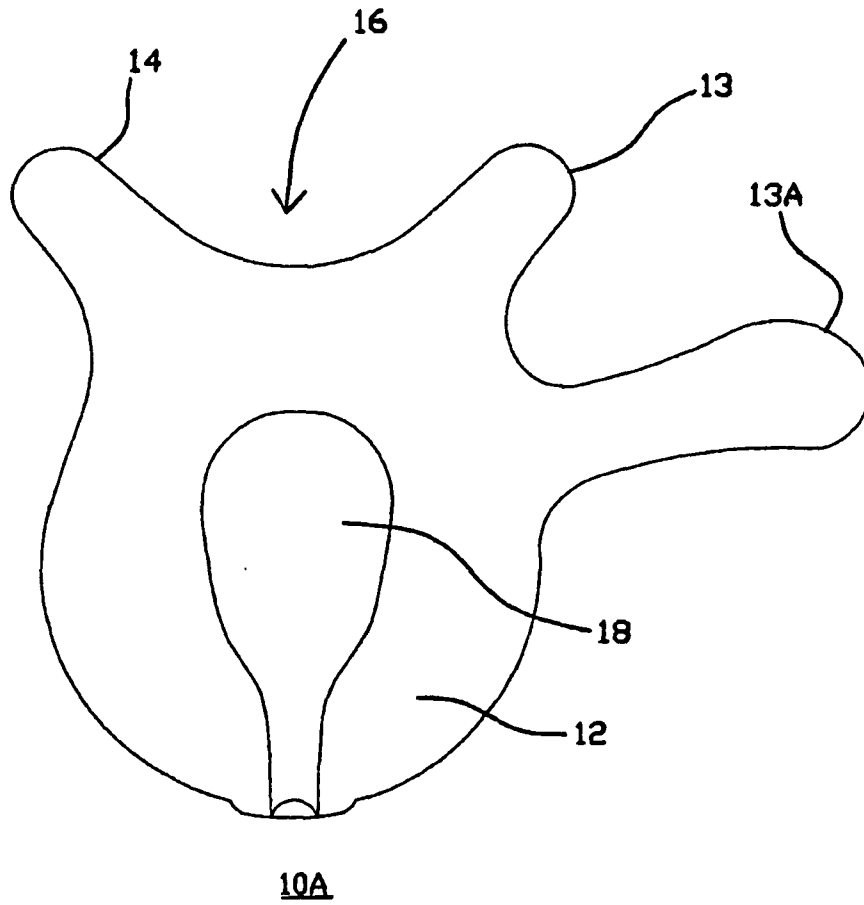

FIG. 2A

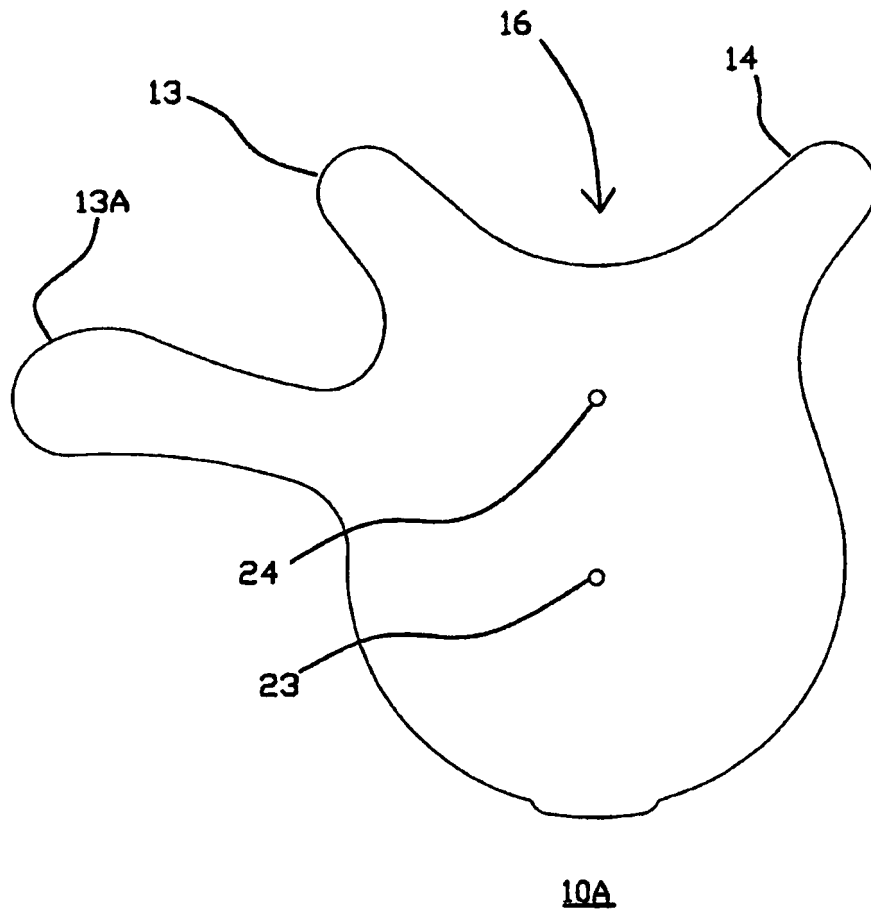

FIG. 2B

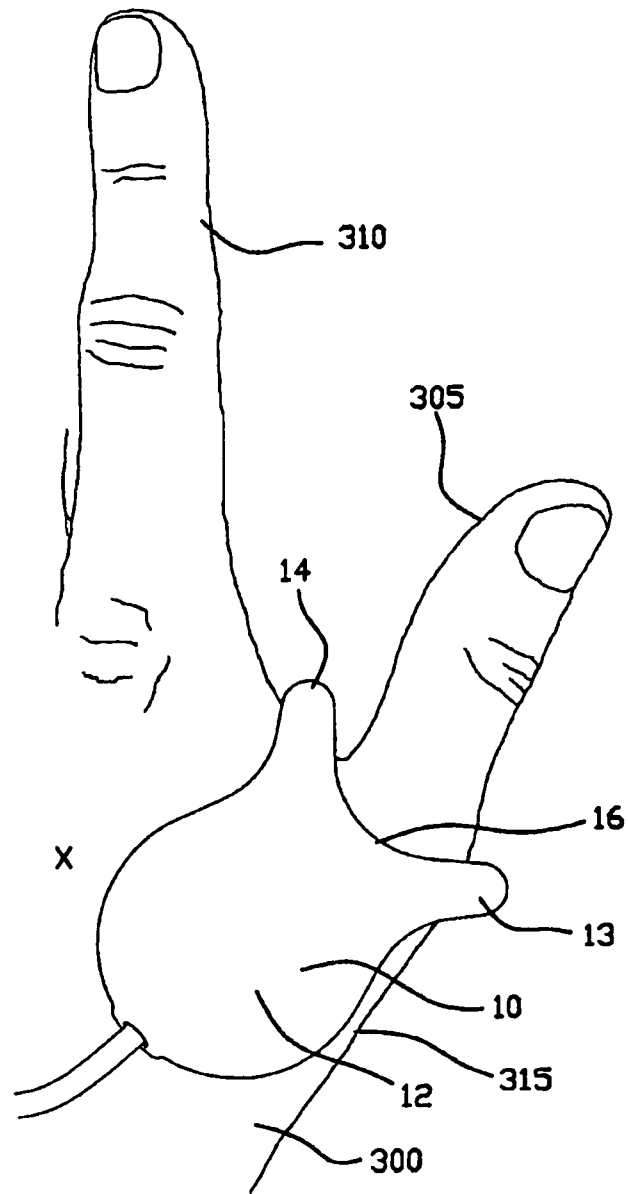

FIG. 3A



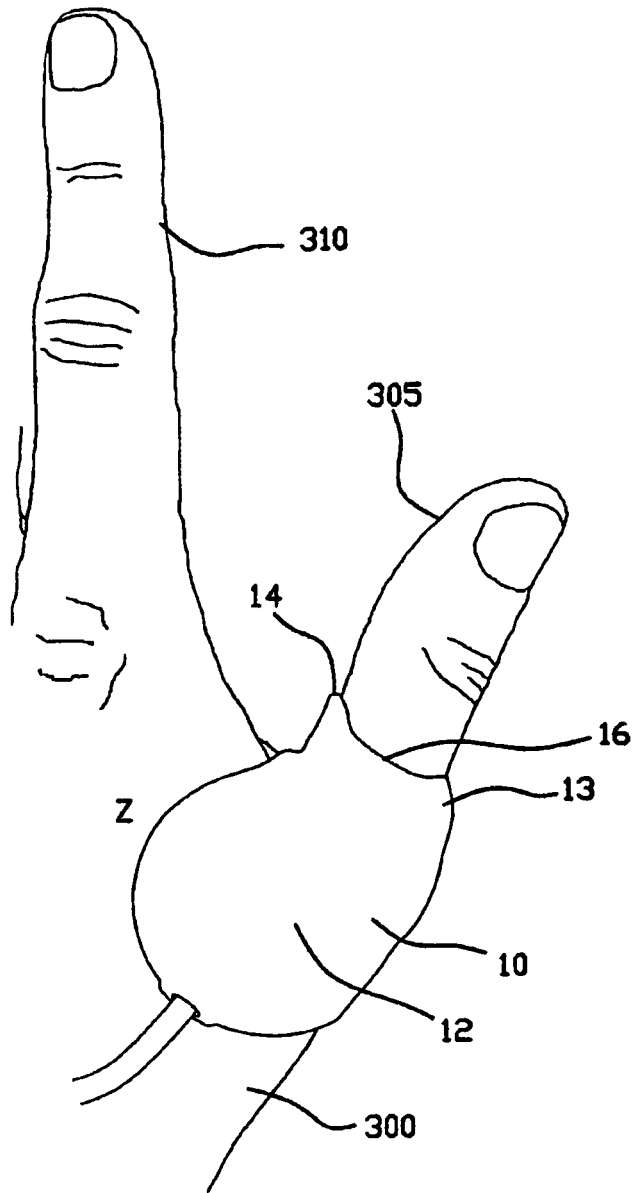

FIG. 3C

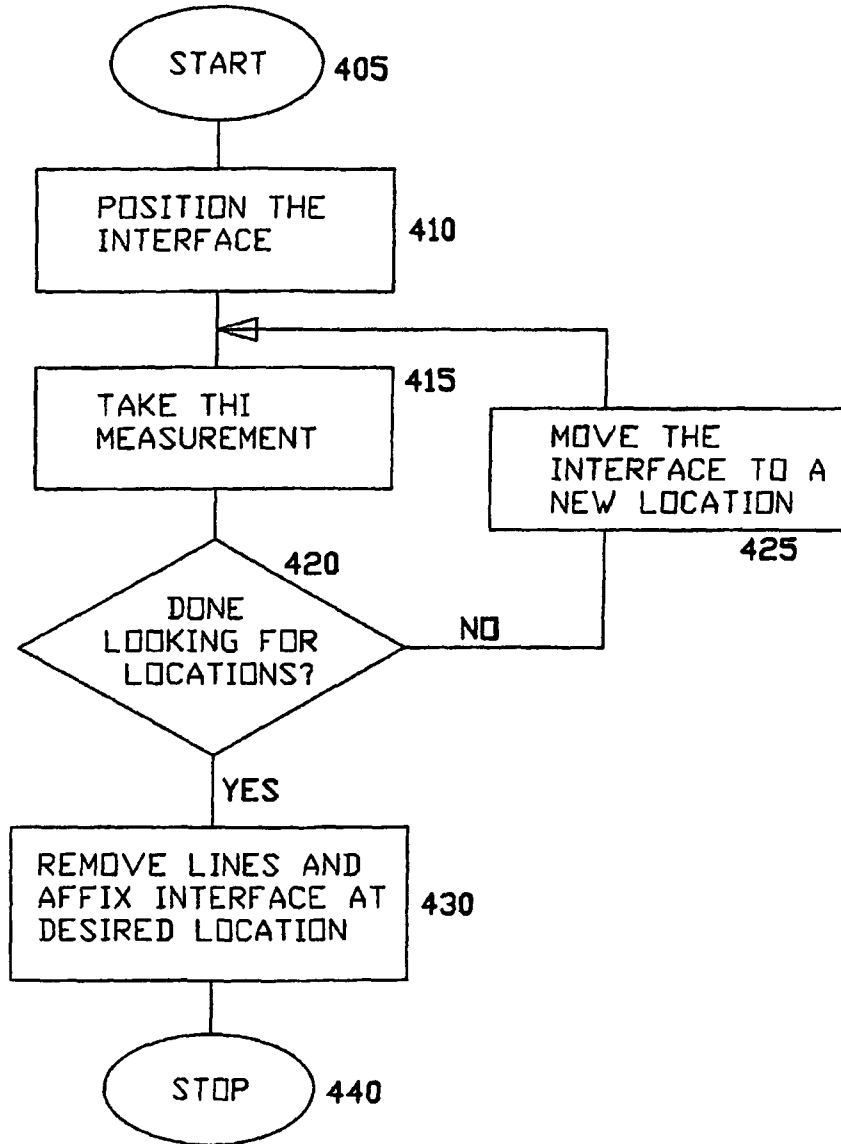

FIG. 4A

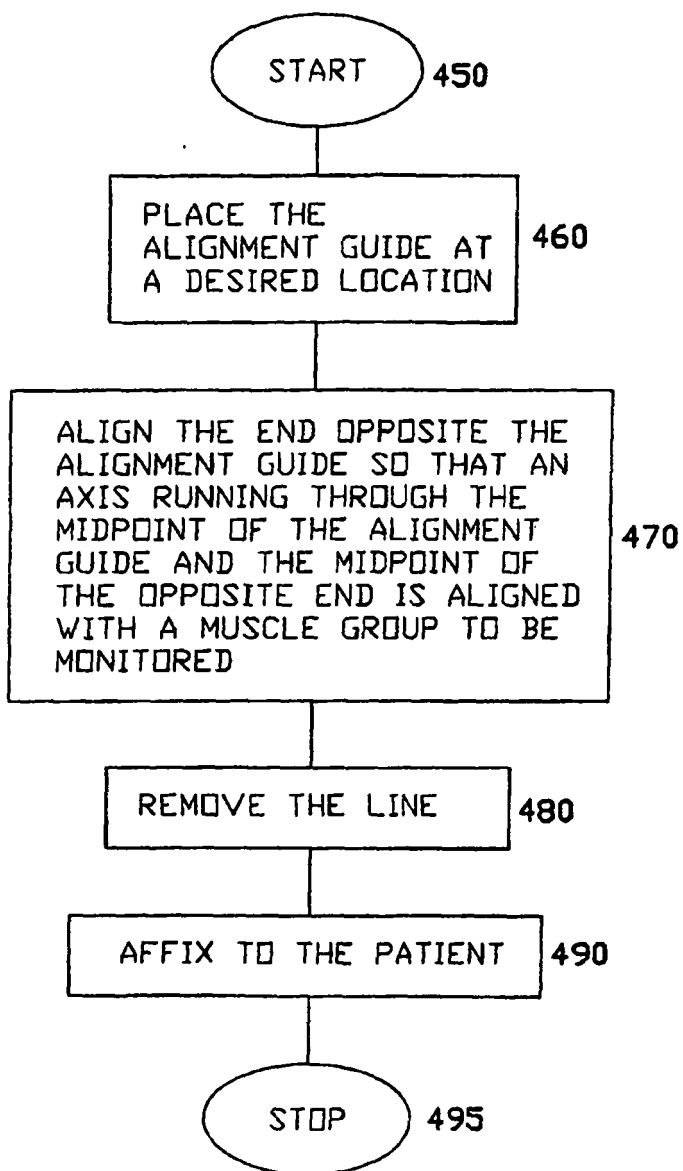

FIG. 4B

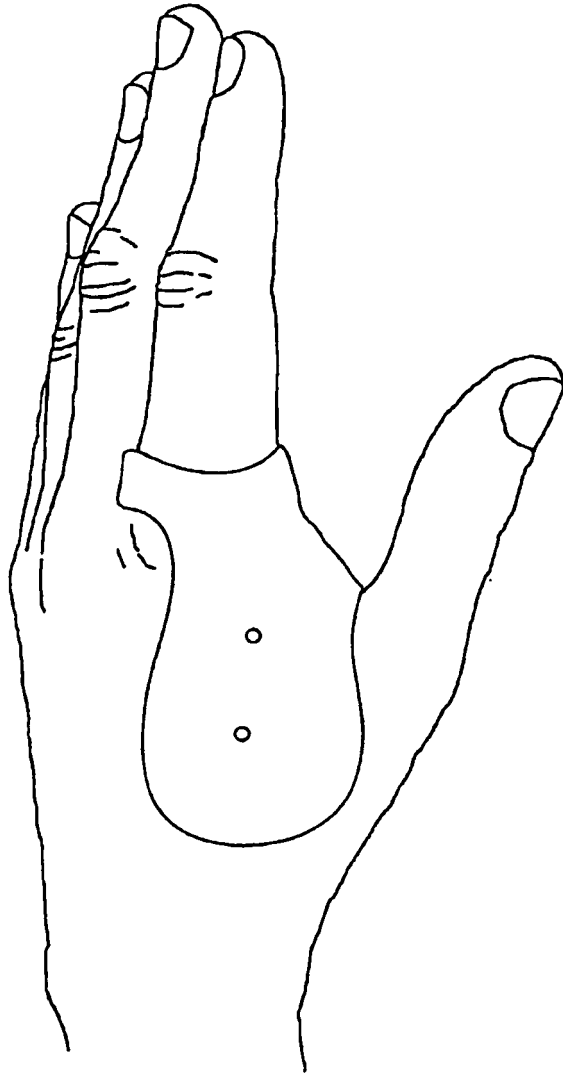

FIG. 5A

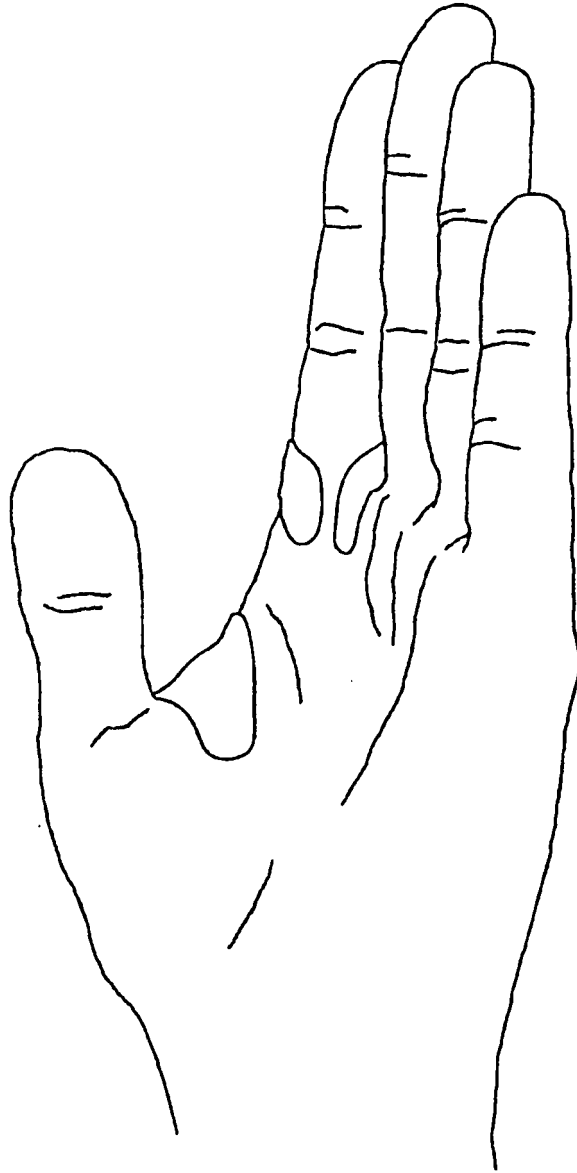

FIG. 5B

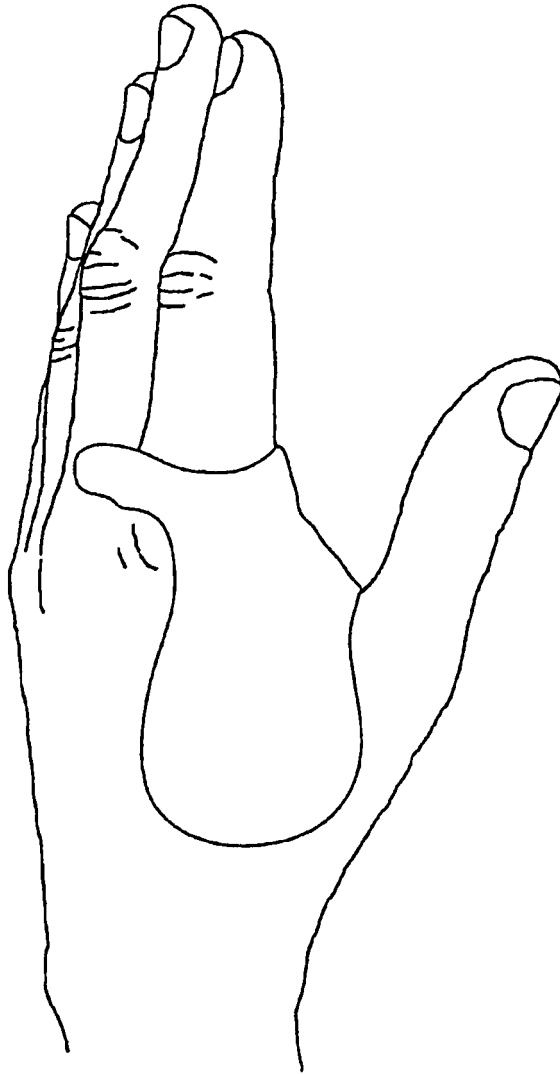

FIG. 5C

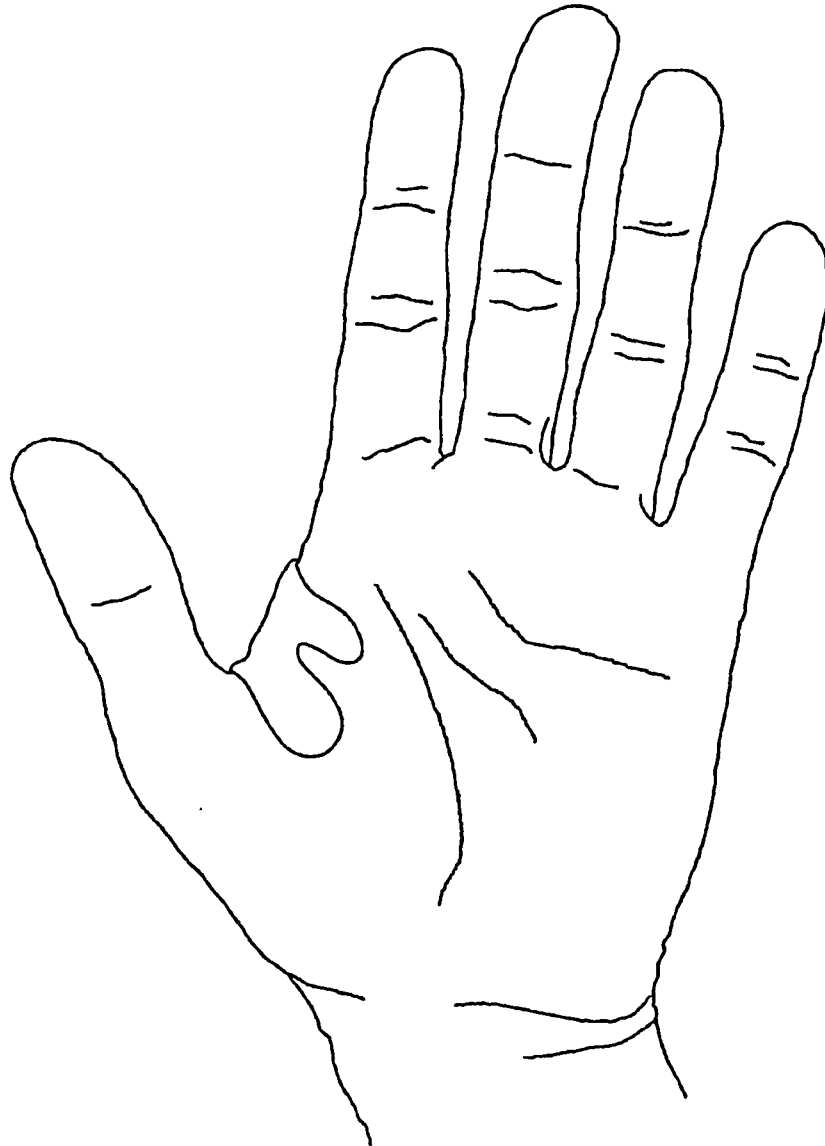

FIG. 5D

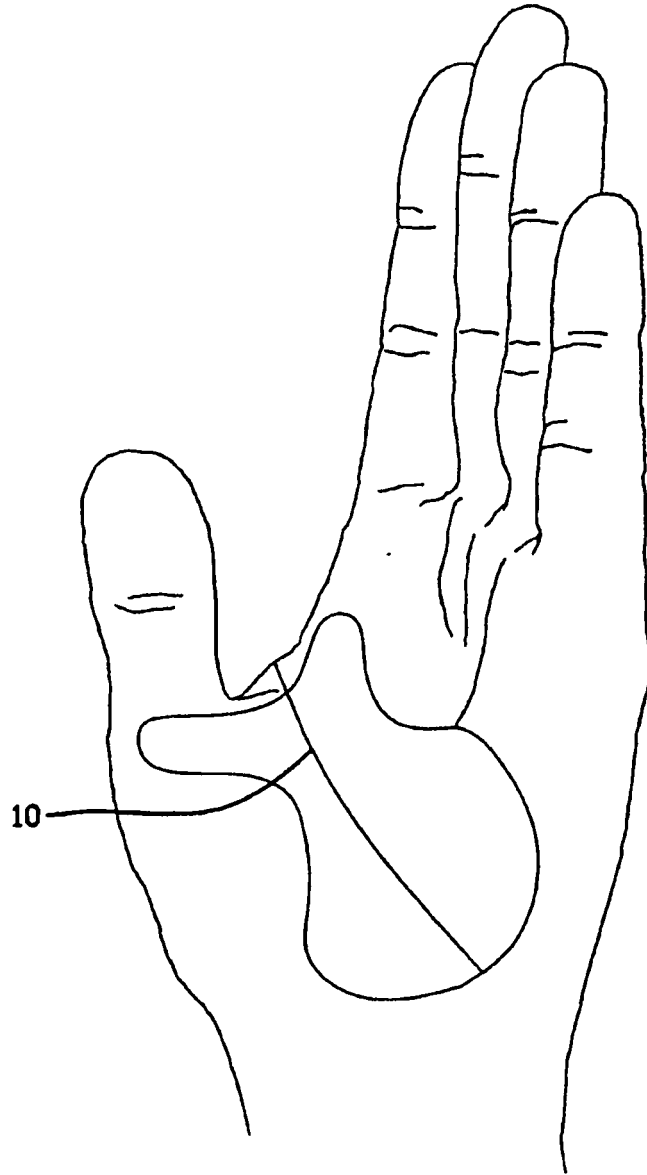

FIG. 6A

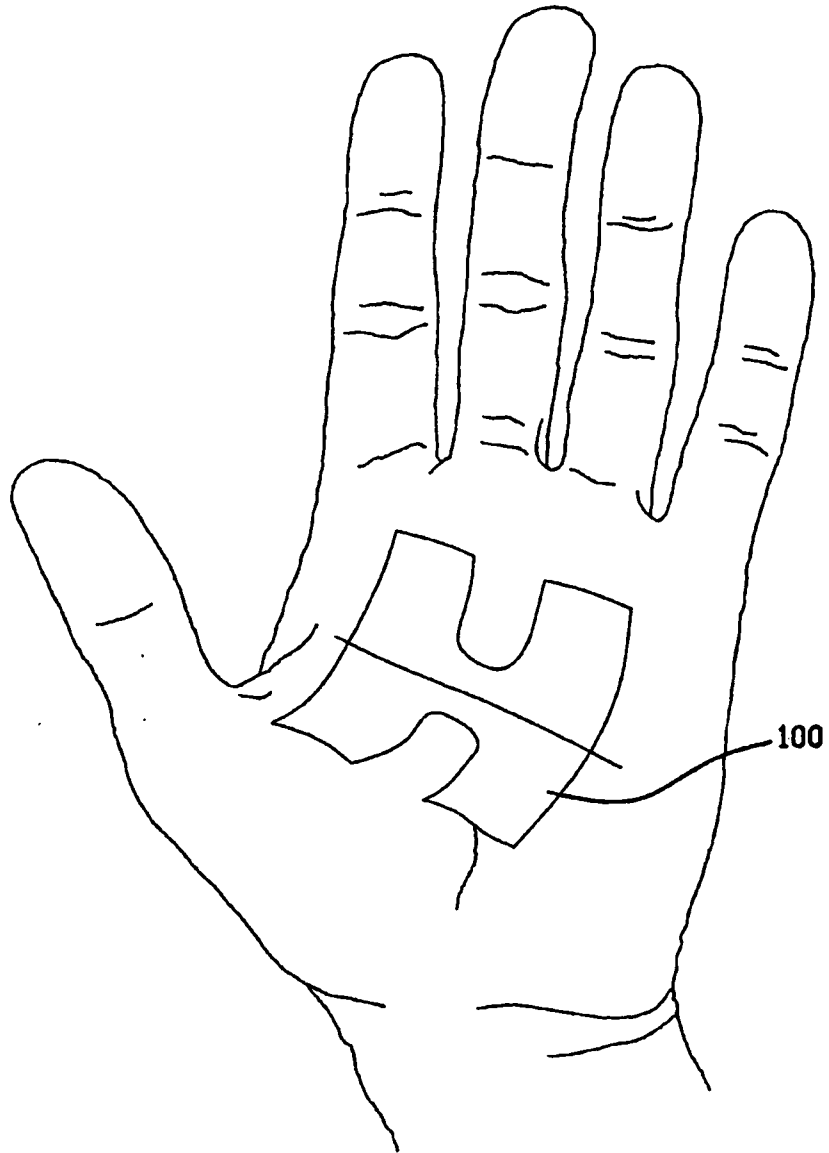

FIG. 6B

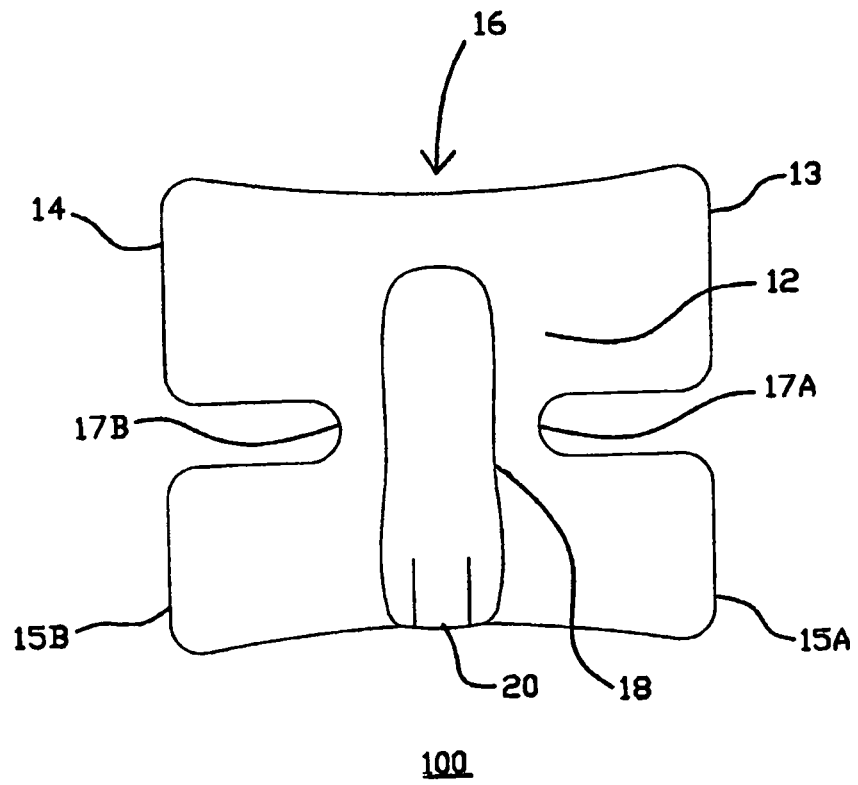

FIG. 7A

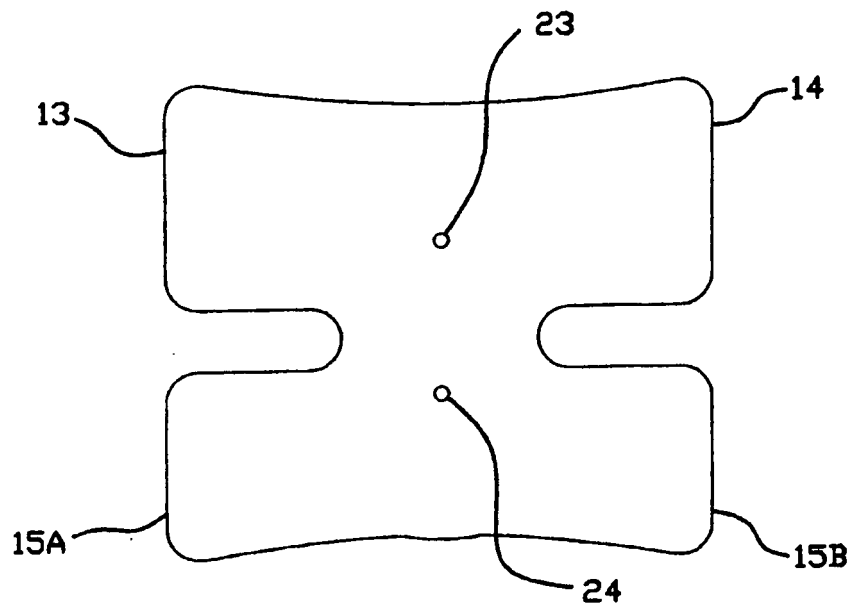

FIG. 7B

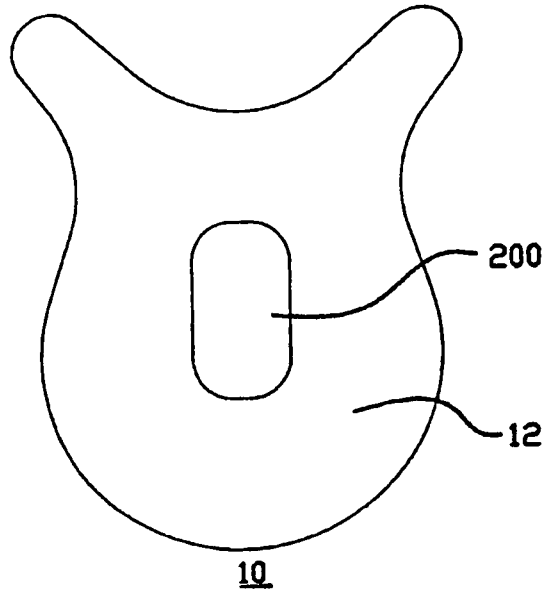

FIG. 8A

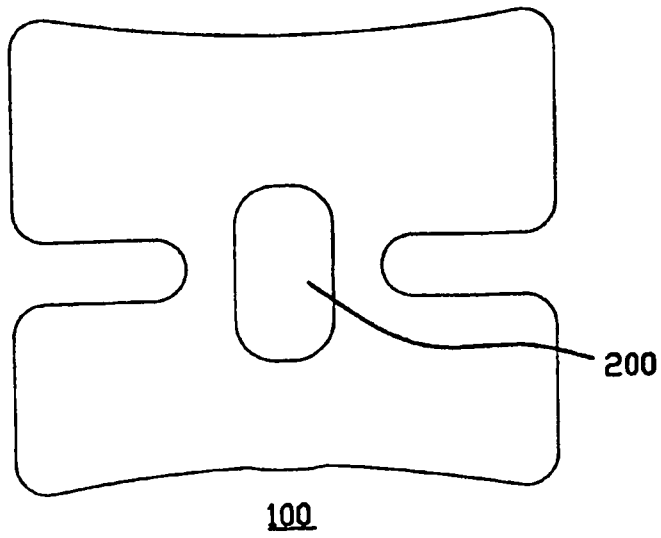

FIG. 8B

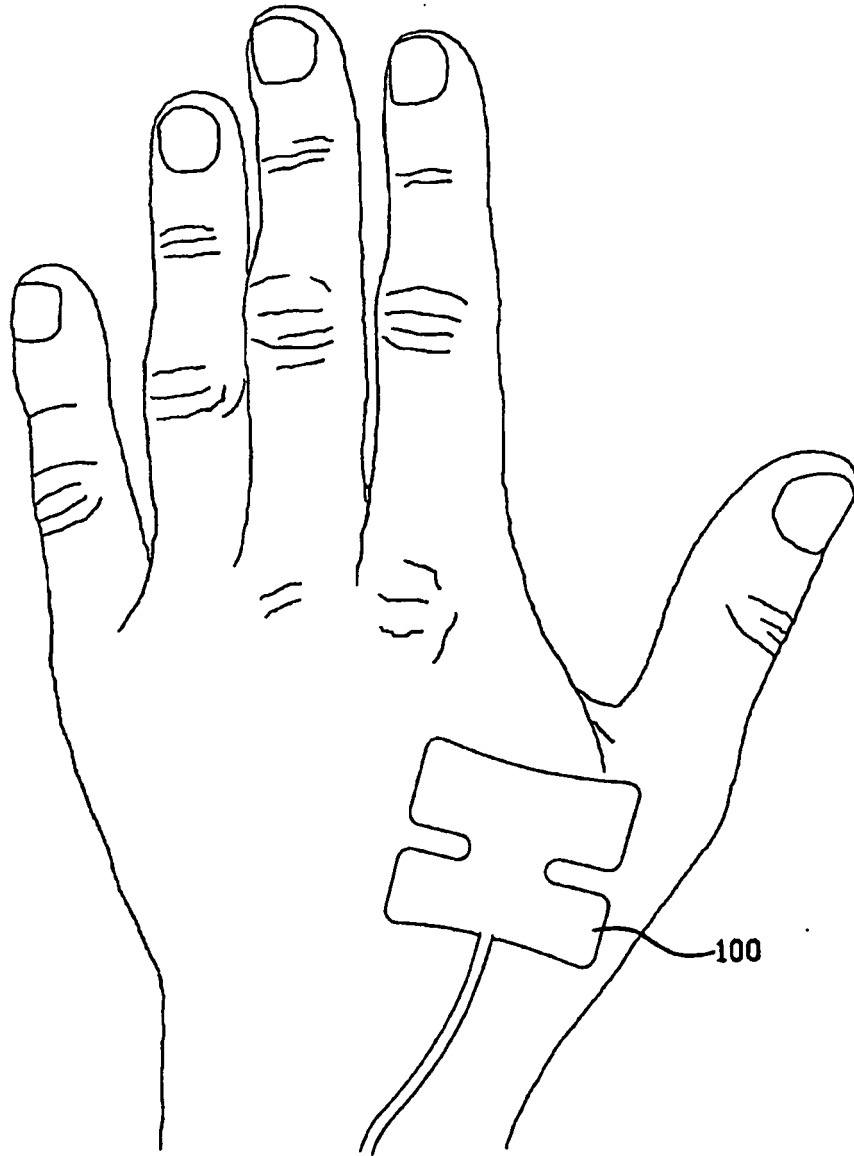

FIG. 9A

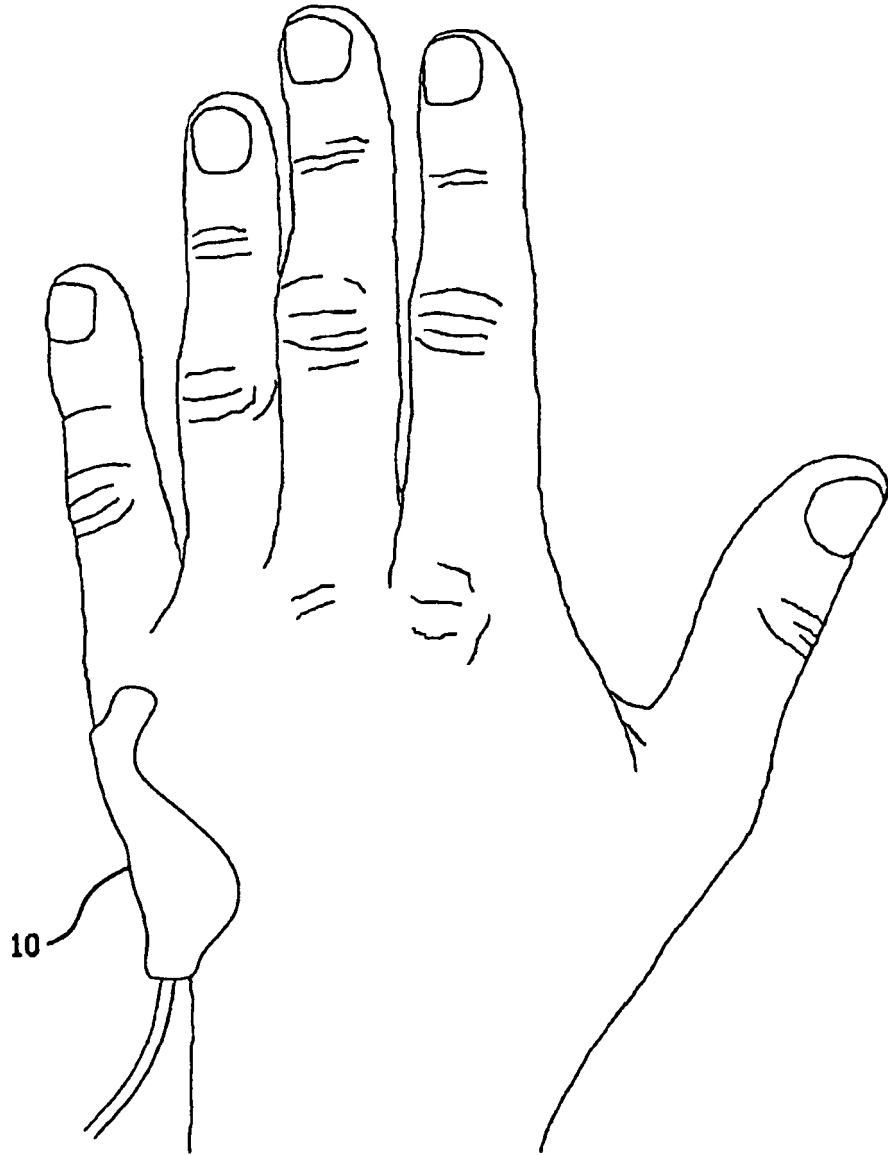

FIG. 9B

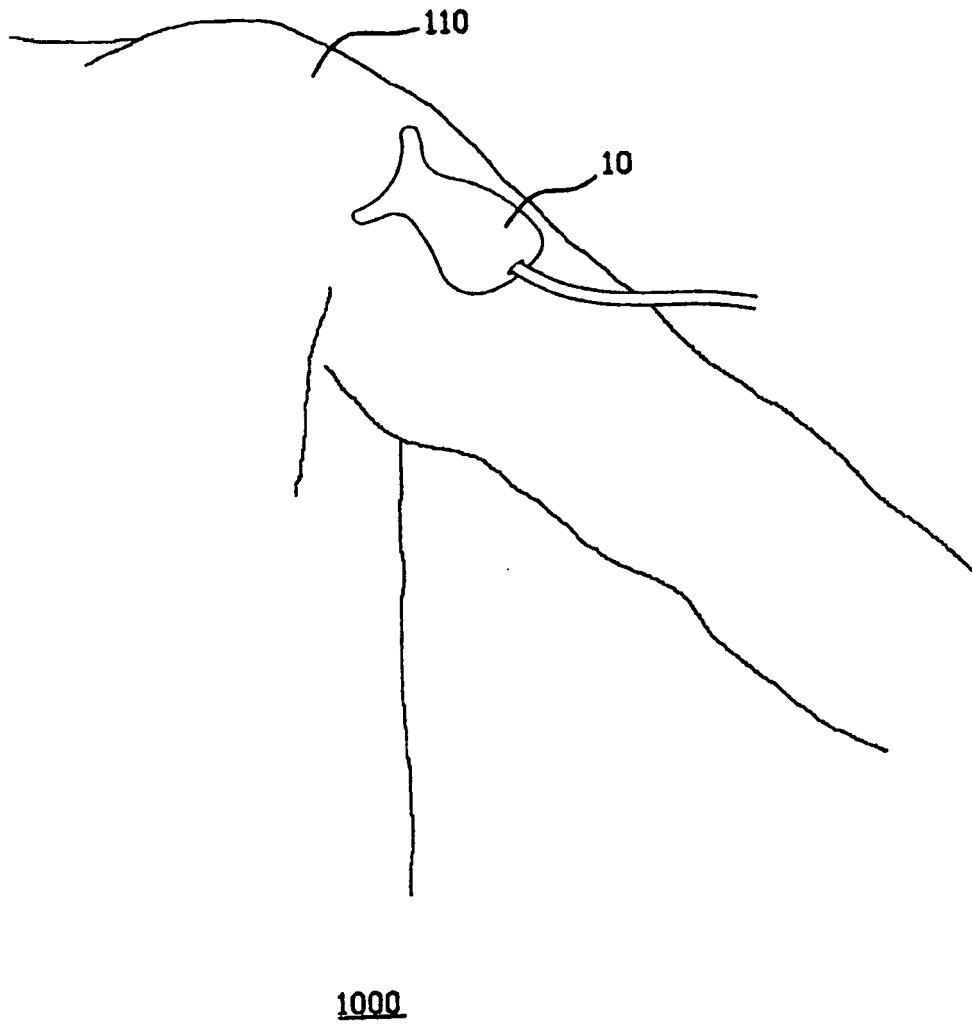

FIG. 10

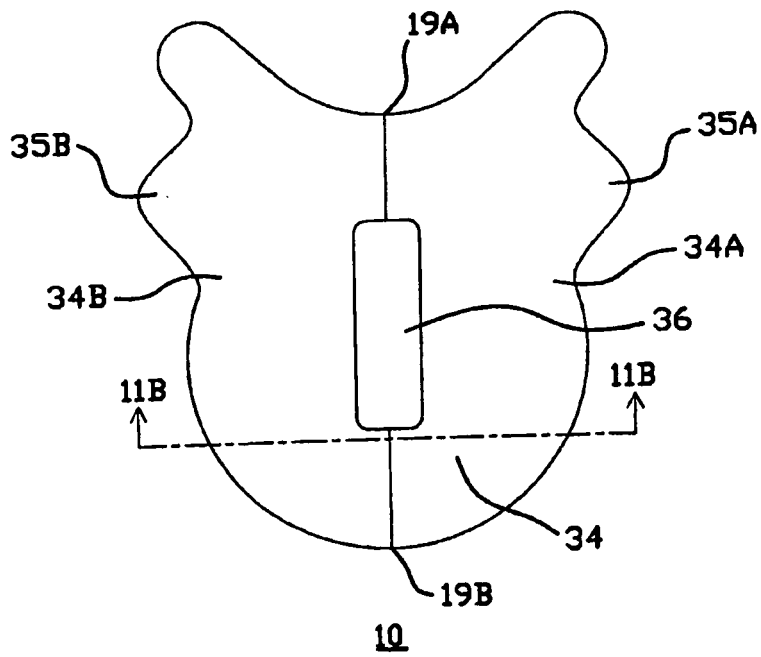

FIG. 11A

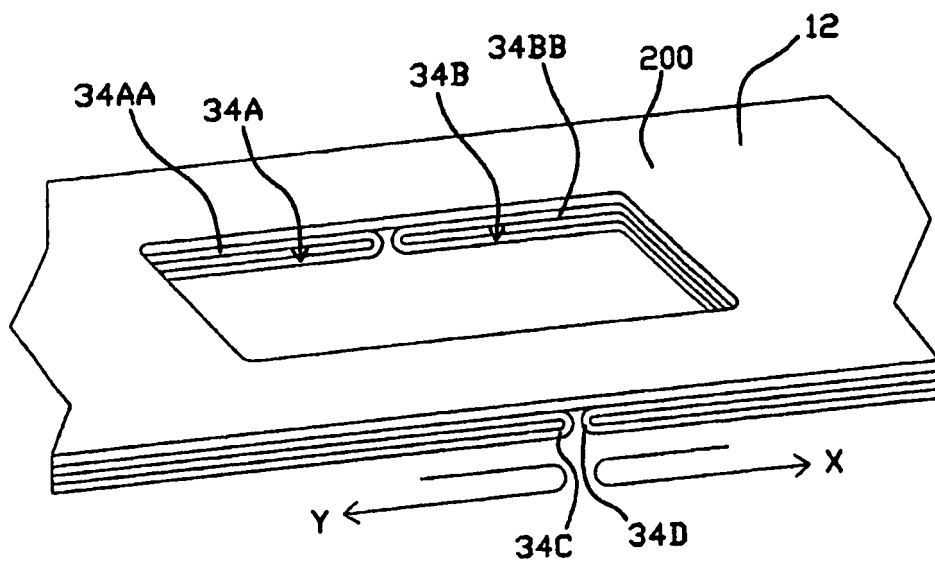

FIG. 11B

**REFERENCES CITED IN THE DESCRIPTION**

*This list of references cited by the applicant is for the reader's convenience only. It does not form part of the European patent document. Even though great care has been taken in compiling the references, errors or omissions cannot be excluded and the EPO disclaims all liability in this regard.*

**Patent documents cited in the description**

- US 4223680 A [0004]
- US 4537197 A [0004]
- US 4653498 A [0004]
- US 4817623 A [0004]
- US 4825879 A [0004]
- US 4830014 A [0004]
- US 4865038 A [0004]
- US 4964408 A [0004]
- US 5094240 A [0004]
- US 5111817 A [0004]
- US 5224478 A [0004]
- US 5267563 A [0004]
- US 5402777 A [0004]
- US 5584296 A [0004]
- US 5879373 A [0004]
- US 6381489 B [0004]
- WO 0228274 A [0005]
- EP 0587009 A [0006]
- WO 0077495 A1 [0008]
- WO 0178587 A2 [0009]
- US 6473632 B [0041]

**Non-patent literature cited in the description**

- **TALPAHEWA, S. P. et al.** Effect of cardiopulmonary bypass on cortical cerebral oxygenation during coronary artery bypass grafting. *European Journal of Cardio-Thoracic Surgery*, 01 October 2004, vol. 26 (4), 676-681 [0007]

|                |   |         |            |
|----------------|---|---------|------------|
| 专利名称(译)        | 用于光谱学应用的患者接口  |         |            |
| 公开(公告)号        | <a href="#">EP2286722B1</a>   | 公开(公告)日 | 2016-07-06 |
| 申请号            | EP2010010019  | 申请日     | 2006-05-08 |
| [标]申请(专利权)人(译) | 哈钦森技术股份有限公司   |         |            |
| 申请(专利权)人(译)    | HUTCHINSON TECHNOLOGY , INC.  |         |            |
| 当前申请(专利权)人(译)  | HUTCHINSON TECHNOLOGY , INC.  |         |            |
| [标]发明人         | ORTNER JOSEPH P<br>SCHEELE BRIAN J  |         |            |
| 发明人            | ORTNER, JOSEPH, P.<br>SCHEELE, BRIAN, J.  |         |            |
| IPC分类号         | A61B5/00 G01N21/35  |         |            |
| CPC分类号         | A61B5/026 A61B5/14535 A61B5/14552 A61B5/4519 A61B5/6824 A61B5/6826 A61B5/6833 A61B5/6838 A61B2562/164 |         |            |
| 优先权            | 11/129935 2005-05-16 US   |         |            |
| 其他公开文献         | EP2286722A1   |         |            |
| 外部链接           | <a href="#">Espacenet</a>   |         |            |

#### 摘要(译)

一种患者接口和定位患者接口的方法，特别是在光谱学应用中。患者接口包括凹入区域以及第一和第二凸出区域。翼从凹陷区域延伸以帮助适当地定位患者接口。凸起区域提供额外的粘附支撑，特别是当用于鱼际隆起时。可以将患者接口放置在患者身上的多个位置，以在将界面固定到患者之前确定用于测量的最佳位置。

