



(11) **EP 1 844 705 B1**

(12) **EUROPEAN PATENT SPECIFICATION**

(45) Date of publication and mention of the grant of the patent:  
**19.08.2009 Bulletin 2009/34**

(51) Int Cl.:  
**A61B 5/00 (2006.01)**

(21) Application number: **07106135.2**

(22) Date of filing: **13.04.2007**

(54) **Eye surgical instrument**

Chirurgisches Instrument für das Auge

Instrument chirurgical ophtalmique

(84) Designated Contracting States:  
**AT BE BG CH CY CZ DE DK EE ES FI FR GB GR HU IE IS IT LI LT LU LV MC MT NL PL PT RO SE SI SK TR**

(30) Priority: **13.04.2006 NL 1031588**

(43) Date of publication of application:  
**17.10.2007 Bulletin 2007/42**

(73) Proprietor: **D.O.R.C. Dutch Ophthalmic Research Center (International) B.V.**  
**3214 VN Zuidland (NL)**

(72) Inventors:  
• **Vijfvinkel, Gerrit Jan**  
**3211 BA, Geervliet (NL)**  
• **Eckardt, Claus Ferdinand**  
**D-61350, Bad Homburg (DE)**

(74) Representative: **van Loon, C.J.J.**  
**Vereenigde**  
**Johan de Wittlaan 7**  
**2517 JR Den Haag (NL)**

(56) References cited:  
**WO-A-98/22805** **US-A- 4 102 342**  
**US-A1- 2003 169 603** **US-A1- 2004 004 846**  
**US-A1- 2005 245 916**

**EP 1 844 705 B1**

Note: Within nine months of the publication of the mention of the grant of the European patent in the European Patent Bulletin, any person may give notice to the European Patent Office of opposition to that patent, in accordance with the Implementing Regulations. Notice of opposition shall not be deemed to have been filed until the opposition fee has been paid. (Art. 99(1) European Patent Convention).

## Description

**[0001]** This invention relates to an eye surgical instrument for lighting the interior of the eye.

**[0002]** Such eye surgical instruments with optical fibers for lighting the interior of the eye are known from practice. Multiple fibers in a bundle of fibers are then connected to one light source. Each fiber has a stop, so that an insertion part of the respective fiber, which is to be placed in the eye, can extend a fixed, predetermined distance into the eye. The known fibers are surrounded up to the stop with a sleeve to prevent light exiting. The stop and the sleeve are fixed at a fixed distance to the end of the fibers. In this way, the length of the insertion part will not change while it is fixed in the eye.

**[0003]** Such optical instruments are for example disclosed in United States patent application publication US2003/0169603. In this publication it is disclosed that during manufacture of the instrument, an optical fiber is inserted through an opening in a stop, and consequently the stop is fixed to the fiber such that the insertion part has a fixed length. One of the disadvantages of this bundle of fibers is that the light often cannot be directed to the desired location in the eye in a precise manner.

**[0004]** This disadvantage and other disadvantages can be counteracted by providing an eye surgical instrument comprising at least one optical fiber for lighting the interior of the eye, which at least one optical fiber is provided at a free end thereof with a light exit and with a stop situated at a distance from the free end, which stop defines an insertion part situated between the end and the stop, and at an other end is connectible to a light source, wherein the fiber is surrounded as far as the light exit by a coating, wherein the stop forms a separate element which is arranged to be slidable along the coating of the at least one fiber.

**[0005]** With the slidable stop, the length of the insertion part can be adjusted in a simple but precise manner and the light in the eye can be directed better to the desired location in the eye.

**[0006]** The invention is based on the insight that the slidable stop enables more precise directing, while surprisingly, precisely by virtue of the simple and controlled adjustability of the projecting part, a desired safety is maintained.

**[0007]** In a preferred embodiment, the stop is arranged to engage the fiber by means of friction. The stop then exerts a frictional force on the fiber, such that the stop can be slid along the fiber with a pair of tweezers.

**[0008]** In another advantageous embodiment, the fiber, adjacent the end thereof, is free of a sleeve over a relatively large part of the length. This creates more sliding room for the stop and so a greater insertion part 10 can be obtained. Preferably, the fiber is further provided with a coating and is relatively thin, for instance of a diameter of less than 0.5 mm. Owing to the free part of the fiber, the coating and/or the small diameter, the fiber and/or the stop can be made of relatively flexible and

hence light design.

**[0009]** Further advantageous embodiments of the invention are set forth in the dependent claims.

**[0010]** The invention further relates to a method for adjusting the length of an insertion part of an eye surgical instrument, wherein the instrument comprises at least a light source, a fiber and a stop, wherein the stop is engaged as a separate element with a pair of tweezers and is slid along the fiber, wherein the fiber is surrounded as far as the light exit by a coating, such that the stop is slid over the coating.

**[0011]** The invention will be further elucidated on the basis of an exemplary embodiment which is represented in the drawings. In the drawings:

15

Figure 1 shows an eye surgical instrument which is uncoupled from a light source, with a part of the length of the instrument omitted in the drawing;

20

Figure 2 shows a detailed representation of the end of a fiber with stop and coating.

**[0012]** It is noted that the figures are only schematic representations of a preferred embodiment of the invention, given by way of non-limiting exemplary embodiment. In the drawing, the same or corresponding parts are designated by the same reference numerals.

**[0013]** In Figure 1 an embodiment of an eye surgical instrument 1 according to the invention is shown which is provided with two optical fibers 2. Each fiber 2 is provided with a free end 3, in this description to be understood as the extreme end of the fiber 2, that is, a point. The eye surgical instrument 1 is further provided with a sleeve 4, to keep the two fibers 2 together over a particular length and to prevent damage and/or contamination of the fibers 2. The eye surgical instrument 1 is further provided with a light source connection 5 for connection of the fibers 2 to a light source, not shown, and a connecting part 6 spanning a part of the connection 5 and of the sleeve 4. Furthermore, the fibers 2 are each provided with a stop 7, slidable along the fibers 2, the sliding directions being indicated by double-headed arrow P.

**[0014]** In Figure 2 an end of fiber 2 is shown which is situated near the free end 3. As shown, the fiber 2 is surrounded over a part of the length by a coating 8 which makes it possible that no light exits from the fiber 2 until a light exit 9. At the light exit 9 the light transported by the eye surgical instrument 1 exits from the fiber 2. An insertion part 10 of the fiber 2, which in use is preferably placed in the eye over approximately the whole length, is defined by the part of the fiber 2 from the free end 3 to the stop 7.

**[0015]** In use, the insertion part 10 is placed in the respective eye of a patient. To that end, for instance with a needle, one or more relatively small perforations or incisions are formed in the sclera of the eye, after which the insertion part 10 is introduced into a perforation to light the interior of the eye. The length of the insertion part 10 can be adjusted so that the light exit 9 can be

55

moved closer to the location in the eye to be lighted, or further away from it. To this end, for instance before but also during insertion of the insertion part 10 into the eye, the stop 7 can be moved along the fiber 2. One way of sliding the stop 7 characteristically involves retracting the fiber 2 partly out of the eye to some extent but still leaving it in the eye, for instance with one hand, and displacing the stop 7 with the other hand, for instance using a pair of tweezers. The insertion part 10 can thereupon be moved into the eye as far as the stop 7, with the stop 7 engaging the eye. Thus, the position of the stop 7 in effect defines a length L of the insertion part 10.

**[0016]** As shown in Figure 1, the fiber 2 adjacent the end 3 thereof is free of the sleeve 4 over a relatively large part of the length. This creates a greater sliding range 11 for the stop 7 and hence a larger insertion part 10 can be obtained.

**[0017]** As the stop 7 exerts frictional force on the fiber 2, in common situations the stop 7 will in principle not move along the fiber 2 and the length of the insertion part 10 will in principle not change while it is placed in the eye. On the other hand, the frictional force is of such magnitude as to allow the specialist in question to slide the stop 7 as an independent element along the fiber 2, preferably using a pair of tweezers. For exerting friction on the fiber 2, the stop 7 is preferably manufactured from slightly flexible material.

**[0018]** In an embodiment, the stop 7 is manufactured substantially from silicone material, which material is favorable for application to the eye. In addition, the stop 7 is substantially somewhat ring-shaped, which makes it relatively simple to produce and to slide and moreover gives it good stop properties.

**[0019]** By virtue of the fiber 2 being of very thin design, a small perforation or incision in the sclera of the eye will suffice for insertion of the insertion part 10. This perforation is for instance provided with a relatively thin needle. Small perforations and/or incisions in the eye will typically close up naturally, so that suture is not necessary. Also, such a relatively small perforation can clamp the fiber 2 in place. This has as a consequence, for instance, that in use the insertion part 10 of the fiber 2 does not readily become dislodged from the perforation, for instance when one of the fibers 2 is knocked against.

**[0020]** In particular embodiments, fibers 2 are used that are known from other technical fields such as telecommunication. In telecommunication, for instance fibers 2 with a thin coating 8 are known with which a small diameter is realized. The fiber is for instance manufactured from polymethylmethacrylate of high purity (high purity PMMA), while the thin coating 8 is manufactured, for instance, from fluorinated PMMA. An advantageous embodiment of the eye surgical instrument utilizes such a fiber 2, which fiber 2 inclusive of coating 8 has for instance a diameter of less than 0.5 mm, in particular between 0.2 and 0.4 mm. The thin diameter is enabled inter alia by virtue of the thinly applied coating 8 which ensures that the light does not exit. For additional protection

against for instance damage or contamination of the fibers 2, a sleeve 4 can be used which surrounds the fibers 2 with coating 8. The sleeve can extend for instance from a point adjacent the light connection 5 to a point adjacent the end of the fiber 2. In a favorable embodiment, a sufficient distance from the end 3 is maintained, so that the stop 7 can be slid over a sufficiently large distance.

**[0021]** In one embodiment, multiple fibers are provided, so that the interior of the eye can be lighted with multiple light exits 9. Preferably, the eye surgical instrument comprises two or three fibers 2. In this way, a relatively simple, light-weight and safe eye surgical instrument is achieved. As a result of a relatively low weight, the thin fiber 2 will less readily fall out of the eye.

**[0022]** The light exit 9 is preferably tapered at the end. This simplifies insertion of the fiber 2 into the eye. In addition, in this way, there is formed for instance a point light source to be directed. The exit 9 may be arranged for converging and/or diverging light, for instance with a convex or concave form, or be provided with a lens.

**[0023]** Instead of using tweezers, the stop 7 can for instance also be displaced with the fingers, preferably using gloves.

**[0024]** In particular embodiments, a or each fiber 2 may be provided with a fixed stop 7 (not shown), in addition to a slidable one. The fixed stop may be provided, for instance, though by no means exclusively so, at the end of the sleeve 4. It is also possible that a fiber 2 has for instance at least one second stop (not shown either) exerting on the fiber 2 approximately the same frictional force as or a higher frictional force than the stop 7. Optionally, the stop 7 could, if desired, be temporarily removed from the fiber 2, so that only the at least one fixed or second stop remains on the fiber 2. This type of second or fixed stops can provide additional safety against the insertion part 10 possibly shooting through in the eye.

**[0025]** The invention is not limited to the exemplary embodiments represented above. Many variants and combinations thereof or elements thereof are possible.

**[0026]** Such variants and combinations will be clear to those skilled in the art and are understood to fall within the scope of the invention as set forth in the following claims.

## Claims

1. An eye surgical instrument (1), comprising at least one optical fiber (2) for lighting of the interior of the eye, which at least one optical fiber (2) is provided at a free end (3) thereof with a light exit (9) and with a stop (7) situated at a distance (L) from the free end (3), which stop (7) defines an insertion part (10) situated between the end (3) and the stop (7), and at an other end thereof is connectible to a light source, **characterized in that** the fiber (2) is surrounded up to the light exit (9) by a coating (8) that prevents exit of light, wherein the stop (7) forms a separate ele-

ment which is arranged to be slidable along the coating (8) of the at least one fiber (2).

2. An instrument (1) according to claim 1, wherein the diameter of the at least one fiber (2) inclusive of coating (8) is between 0.2 and 0.5 mm, in particular between 0.2 and 0.4 mm.
3. An instrument (1) according to claim 1 or 2, wherein the stop (7) is an annular element of silicone material which surrounds the fiber (2).
4. An instrument (1) according to any one of the preceding claims, provided with a sleeve (4) which at a distance from the stop (7) surrounds a part of the fiber (2), preferably as far as a point adjacent the other end, for protecting the fiber (2) and/or the coating (8) from damage.
5. An instrument (1) according to any one of the preceding claims, wherein multiple fibers (2) are provided in one sleeve (4), preferably two or three fibers (2).
6. An instrument (1) according to any one of the preceding claims, wherein the fibers (2) at the other end thereof are provided with a connecting element for cooperation with the light source.
7. A method for adjusting the length (L) of an insertion part (10) of an eye surgical instrument (1), wherein the instrument (1) comprises at least a light source, a fiber (2) and a stop (7), **characterized in that** the stop (7) is engaged as a separate element with a pair of tweezers and is slid along the fiber (2), wherein the fiber (2) is surrounded up to the light exit (9) by a coating (8) that prevents light from exiting, and the stop (7) is slid over the coating (8)

#### Patentansprüche

1. Augenchirurgisches Instrument (1), umfassend wenigstens eine optische Faser (2) zum Beleuchten des Inneren des Auges, wobei wenigstens eine optische Faser (2) an einem freien Ende (3) derselben mit einer Lichtaustrittsöffnung (9) und mit einem Stopper (7), der sich in einem Abstand (L) vom freien Ende (3) befindet, ausgestattet ist, wobei der Stopper (7) einen Einführungsteil (10) definiert, der sich zwischen dem Ende (3) und dem Stopper (7) befindet, und an einem anderen Ende an eine Lichtquelle anschließbar ist, **dadurch gekennzeichnet, dass** die Faser (2) bis zur Lichtaustrittsöffnung (9) mit einer Beschichtung (8) umgeben ist, die einen Austritt von Licht verhindert, wobei der Stopper (7) ein getrenntes Element bildet, das so angeordnet ist, dass es entlang der Beschichtung (8) der wenigstens einen Faser (2) verschiebbar ist.

2. Instrument (1) gemäß Anspruch 1, wobei der Durchmesser der wenigstens einen Faser (2) einschließlich der Beschichtung (8) zwischen 0,2 und 0,5 mm, insbesondere zwischen 0,2 und 0,4 mm, liegt.
3. Instrument (1) gemäß Anspruch 1 oder 2, wobei der Stopper (7) ein ringförmiges Element aus Silikonmaterial, das die Faser (2) umgibt, ist.
4. Instrument (1) gemäß einem der vorangehenden Ansprüche, das mit einer Hülse (4) ausgestattet ist, welche in einem Abstand vom Stopper (7) einen Teil der Faser (2) umgibt, vorzugsweise bis zu einem Punkt benachbart dem anderen Ende, zum Schutz der Faser (2) und/oder der Beschichtung (8) vor Beschädigung.
5. Instrument (1) gemäß einem der vorangehenden Ansprüche, wobei mehrere Fasern (2) in einer Hülse (5), vorzugsweise 2 oder 3 Fasern (2), angeordnet sind.
6. Instrument (1) gemäß einem der vorangehenden Ansprüche, wobei die Fasern (2) am anderen Ende davon mit einem Verbindungselement zur Kooperation mit der Lichtquelle versehen sind.
7. Verfahren zum Einstellen der Länge (L) eines Einführungsteils (10) eines augenchirurgischen Instruments (1), wobei das Instrument (1) wenigstens eine Lichtquelle, eine Faser (2) und einen Stopper (7) umfasst, **dadurch gekennzeichnet, dass** der Stopper (7) als getrenntes Element mit einer Pinzette in Eingriff gebracht wird und entlang der Faser (2) verschoben wird, wobei die Faser (2) bis zu der Lichtaustrittsöffnung (9) mit einer Beschichtung (8) umgeben ist, die einen Austritt von Licht verhindert, und der Stopper (7) über die Beschichtung (8) geschoben wird.

#### Revendications

1. Instrument chirurgical ophtalmique (1), comprenant au moins une fibre optique (2) pour éclairer l'intérieur de l'oeil, ladite au moins une fibre optique (2) étant munie, à une extrémité (3) libre de celle-ci, d'une sortie de lumière (9) et avec une butée (7) située à une distance (L) de l'extrémité (3) libre, ladite butée (7) définissant une partie d'insertion (10) située entre l'extrémité (3) et la butée (7) et, à une autre extrémité de celle-ci, est susceptible d'être connectée à une source lumineuse, **caractérisé en ce que** la fibre (2) est entourée, jusqu'à la sortie de lumière (9), par un revêtement (8) empêchant la sortie de lumière, dans lequel la butée (7) forme un élément séparé, agencé pour pouvoir coulisser le long du revêtement

(8) de la au moins une fibre (2).

2. Instrument (1) selon la revendication 1, dans lequel le diamètre de la au moins une fibre (2), en incluant le revêtement (8), est compris dans la fourchette allant de 0,2 à 0,5 mm, en particulier dans la fourchette allant de 0,2 à 0,4 mm. 5
  
3. Instrument (1) selon la revendication 1 ou 2, dans lequel la butée (7) est un élément annulaire formé d'un matériau en silicone, entourant la fibre (2). 10
  
4. Instrument (1) selon l'une quelconque des revendications précédentes, muni d'une gaine (4) entourant, à une certaine distance de la butée (7), une partie de la fibre (2), de préférence jusqu'à un point adjacent à l'autre extrémité, pour protéger la fibre (2) et/ou le revêtement (8) de tout endommagement. 15
  
5. Instrument (1) selon l'une quelconque des revendications précédentes, dans lequel une pluralité de fibres (2), de préférence deux ou trois fibres (2), sont prévues dans une gaine (4). 20
  
6. Instrument (1) selon l'une quelconque des revendications précédentes, dans lequel, à leur autre extrémité, les fibres (2) sont munies d'un élément de connexion devant coopérer avec la source lumineuse. 25
  
7. Procédé pour ajuster la longueur (L) d'une partie d'insertion (10) d'un instrument chirurgical ophtalmique (1), dans lequel l'instrument (1) comprend au moins une source lumineuse, une fibre (2) et une butée (7), **caractérisé en ce que** la butée (7) est mise en prise, en tant qu'élément séparé, avec une pince et est coulissée le long de la fibre (2), dans lequel la fibre (2) est entourée, jusqu'à la sortie de lumière (9), par un revêtement (8) empêchant la lumière de sortir, et la butée (7) est coulissée sur le revêtement (8). 30  
35  
40

45

50

55

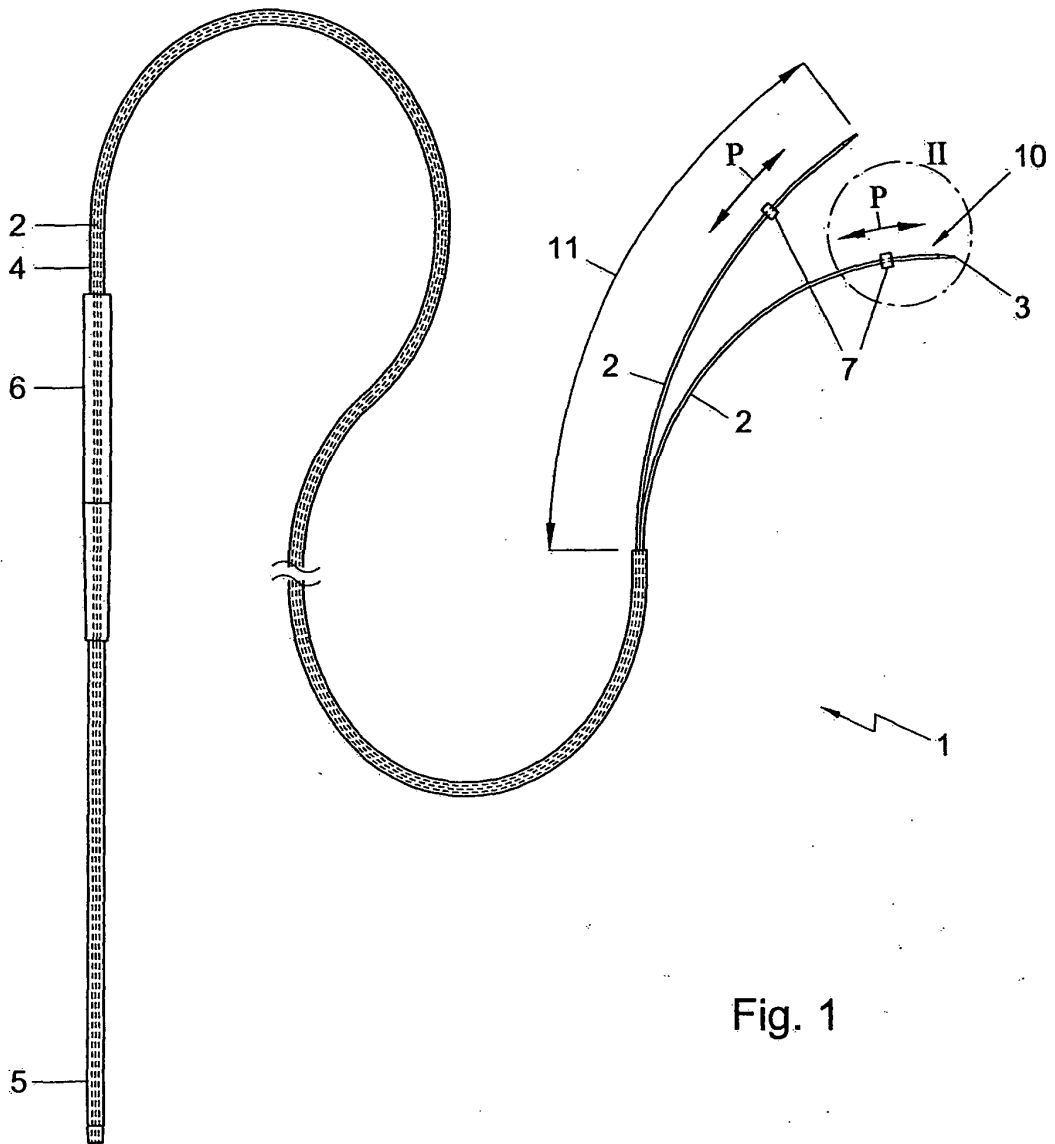

Fig. 1

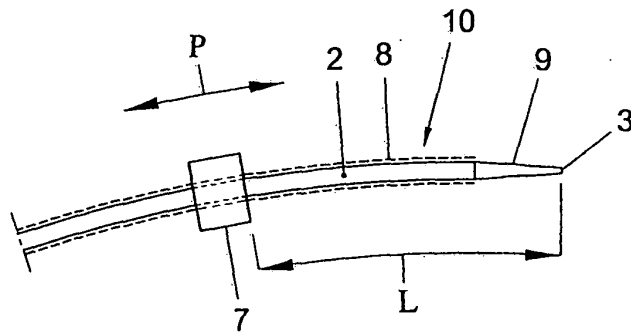

Fig. 2

**REFERENCES CITED IN THE DESCRIPTION**

*This list of references cited by the applicant is for the reader's convenience only. It does not form part of the European patent document. Even though great care has been taken in compiling the references, errors or omissions cannot be excluded and the EPO disclaims all liability in this regard.*

**Patent documents cited in the description**

- US 20030169603 A [0003]

专利名称(译)	眼科手术器械		
公开(公告)号	<a href="#">EP1844705B1</a>	公开(公告)日	2009-08-19
申请号	EP2007106135	申请日	2007-04-13
[标]申请(专利权)人(译)	DUTCH眼科RES CENT INT		
申请(专利权)人(译)	D.O.R.C. DUTCH眼科研究中心 ( 国际 ) B.V.		
当前申请(专利权)人(译)	D.O.R.C. DUTCH眼科研究中心 ( 国际 ) B.V.		
[标]发明人	VIJFVINKEL GERRIT JAN ECKARDT CLAUS FERDINAND		
发明人	VIJFVINKEL, GERRIT JAN ECKARDT, CLAUS FERDINAND		
IPC分类号	A61B5/00		
CPC分类号	A61B5/0084 A61B3/0008 A61B2090/306 A61F9/007		
优先权	1031588 2006-04-13 NL		
其他公开文献	EP1844705A1		
外部链接	<a href="#">Espacenet</a>		

摘要(译)

一种眼外科手术器械，包括至少一根用于照亮眼睛内部的光纤，至少一根光纤在其自由端设有光出口和位于距自由光阑一定距离的光阑。端部，该止挡限定了位于端部和止挡之间的插入部分，并且在另一端可连接到光源，而止挡形成单独的元件，该元件布置成可沿着至少一根光纤滑动。

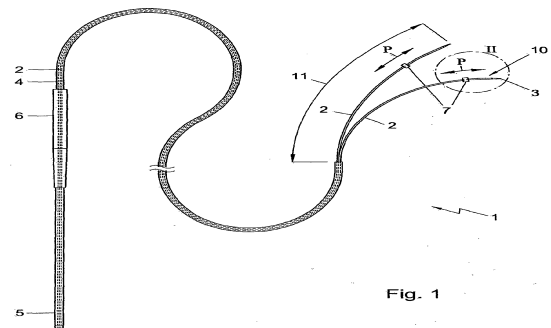

Fig. 1

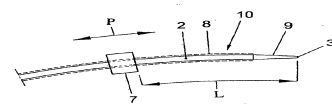

Fig. 2