



(11) **EP 1 694 203 B1**

(12) **EUROPEAN PATENT SPECIFICATION**

(45) Date of publication and mention of the grant of the patent:
26.08.2009 Bulletin 2009/35

(21) Application number: **05701821.0**

(22) Date of filing: **10.01.2005**

(51) Int Cl.:
A61B 5/00 (2006.01) A61B 5/103 (2006.01)

(86) International application number:
PCT/GB2005/000051

(87) International publication number:
WO 2005/065533 (21.07.2005 Gazette 2005/29)

(54) **A SYSTEM OR METHOD FOR ASSESSING A SUBJECT'S PERIPHERAL BLOOD CIRCULATION**
SYSTEM ODER VERFAHREN ZUR BEURTEILUNG DER PERIPHEREN BLUTZIRKULATION EINER PERSON
SYSTEME OU METHODE D'EVALUATION DE LA CIRCULATION SANGUINE PERIPHERIQUE D'UN SUJET

(84) Designated Contracting States:
AT BE BG CH CY CZ DE DK EE ES FI FR GB GR HU IE IS IT LI LT LU MC NL PL PT RO SE SI SK TR

(30) Priority: **08.01.2004 GB 0400281**

(43) Date of publication of application:
30.08.2006 Bulletin 2006/35

(60) Divisional application:
09166048.0
09166058.9

(73) Proprietor: **DIALOG DEVICES LIMITED**
Loughborough
Leicestershire LE11 3TU (GB)

(72) Inventors:
• **CRABTREE, Vincent, Peter**
Loughborough,
Leicestershire LE11 3TU (GB)
• **SMITH, Peter Richard**
Griffydham,
Leicestershire LE67 8HX (GB)

(74) Representative: **Higgin, Paul**
Swindell & Pearson
48 Friar Gate
Derby DE1 1GY (GB)

(56) References cited:
WO-A-98/17174 **DE-A1- 3 744 538**
US-A- 5 137 023

EP 1 694 203 B1

Note: Within nine months of the publication of the mention of the grant of the European patent in the European Patent Bulletin, any person may give notice to the European Patent Office of opposition to that patent, in accordance with the Implementing Regulations. Notice of opposition shall not be deemed to have been filed until the opposition fee has been paid. (Art. 99(1) European Patent Convention).

Description

FIELD OF THE INVENTION

5 **[0001]** Embodiments of the invention relate to assessing a subject's peripheral blood circulation, in particular, but not exclusively, arterial blood flow to the foot.

BACKGROUND TO THE INVENTION

10 **[0002]** US 5137023 discloses a non-invasive system for measuring the concentration of an analyte such as glucose, in an absorbing matrix. WO 98/17174 describes a non-invasive method for determining the absolute level of oxygen saturation in blood. Both of these documents describe the taking of measurements at different wave lengths of light.

[0003] Healthy peripheral circulation is an important factor in quality of life, independent living and personal freedom. Disorders of the vascular system can arise from a number of diseases such as, for example, diabetes, arteriosclerosis, Raynaud's syndrome, atherosclerosis.

15 **[0004]** There are a few clinic/GP based technologies that are used currently to assess peripheral blood circulation. However, these technologies are generally interpretive and must be practised by a correctly trained person.

BRIEF DESCRIPTION OF THE INVENTION

20 **[0005]** It would be desirable to provide for the objective assessment of peripheral blood circulation.

[0006] According to one aspect of the invention, there is provided a system for assessing blood circulation in a subject's limb, comprising: detection means for detecting a signal dependent upon the arterial blood volume in a limb of the subject when the subject is in a first posture and also when the subject is

25 in a second posture, different to the first posture; and processing means for calculating a quantitative indicator that is dependent upon the ratio of the signal for the first posture to the signal for the second posture.

[0007] According to this aspect of the invention, there is provided a method for assessing blood circulation in a subject's limb, comprising: detecting a signal dependent upon the arterial blood volume in a limb of the subject when the subject is in a first posture; detecting the signal dependent upon the arterial blood volume in the limb of the subject when the subject is in a second posture, different to the first posture; and calculating a quantitative indicator that is dependent upon the ratio of the signal for the first posture to the signal for the second posture.

[0008] The signal may be a pulsating (arterial) component of a measured parameter, the measured parameter being dependent upon the blood volume in the subject's limb.

[0009] The signal may be dependent upon the volume of arterial blood in the limb and other subject specific factors. The ratio of signals at different postures eliminates the subject specific factors and provides an objective indicator.

[0010] The measured parameter may, for example, be the intensity of light reflected from the limb. The intensity of the reflected light may be modelled as an attenuation of the intensity of incident light by a first exponential factor and a second exponential factor. The first exponential factor has a first exponent that represents the light absorption by arterial blood of the subject, The second exponential factor has a second exponent that represents the light absorption by other

40 factors including venous blood for the subject. According to this model, rapid variations in the measured parameter arise from the first exponent. The first exponent is very small and the first exponential factor can therefore be represented mathematically as a first order polynomial (i.e. $1 + \text{first exponent}$). A good approximation of the first exponent may be obtained, for example, by taking the ratio of the ac component of the measured parameter to the dc component of the measured parameter. Also according to this model, the first exponent comprises a factor that represents the light absorbency of the subject's arterial blood and a factor that represents the volume of the subject's arterial blood. According to this model, as the light absorbency of a subject's arterial blood remains constant between postural changes, then the ratio of the first exponent for a first posture to the first exponent for a second posture gives a 'pure' ratio of arterial volumes without other factors. This ratio can therefore be used as an objective quantitative indicator.

45 **[0011]** Embodiments of the invention therefore provide a quantitative indicator in a robust and quick manner at modest cost without discomfort to the user. Some embodiments may be automated,

BRIEF DESCRIPTION OF THE DRAWINGS

55 **[0012]** For a better understanding of the present invention reference will now be made by way of example only to the accompanying drawings in which:

Fig. 1 schematically illustrates a system 10 for the objective assessment of blood perfusion in a lower limb 12 of a subject;

Fig. 2 illustrates a system 10 for the objective assessment of blood perfusion in a lower limb 12 of a subject using an optical sensor 4;

Fig. 3 schematically illustrates the components of the system illustrated in Fig. 2.

Figs. 4A and 4B illustrate the change in pulsatile perfusion for a healthy subject's leg when raised to 30 degrees; and

Figs. 5A and 5B illustrate the change in pulsatile perfusion for an at risk subject's leg when raised to 30 degrees. '

DETAILED DESCRIPTION OF EMBODIMENT OF THE INTENTION

[0013] The Figures illustrate a system 10 for assessing blood circulation in a subject's limb, comprising: detection means for detecting a signal dependent upon the arterial blood volume in a limb of the subject when the subject is in a first posture and also when the subject is in a second posture, different to the first posture; and processing means 5 for calculating a quantitative indicator that is dependent upon the ratio of the signal for the first posture to the signal for the second posture.

[0014] The blood volume in a lower limb includes a variable volume, and a fixed volume. The variable blood volume arises from pulsating blood flow within the arteries of the lower limb and varies with a periodicity in the range 0.5-3Hz. The fixed volume includes the venous volume of blood and varies, if at all, over a time scale of several seconds.

[0015] The blood circulation system is governed in part by forces exerted by gravity. In order that a suitable blood flow is maintained throughout the body, the vascular system can adjust to any local pressure changes resulting from postural changes. Thus the resistance of the peripheral vascular system in the feet is high when a subject is standing compared with when they are supine. Although the relationships between pressure, flow and blood volume are complex, certain patterns can be identified that characterise the response of the circulation system to specific changes (e.g. postural changes). These patterns can be disrupted when a pathology is present such as an arterial blockage or when the vasculature has a reduced capability to respond to changes imposed upon it. This is the principle of response testing which is exploited in this invention.

[0016] When a lower limb is raised above the heart, the circulation system will respond to the change in localised blood pressure in a manner characteristic of any pathology. This characteristic change is detected by measuring changes in the blood volume in the limb.

[0017] Fig. 1 schematically illustrates a system 10 for the objective assessment of blood perfusion in a lower limb 12 of a subject. The system 10 automatically determines quantitative indicators of lower limb blood perfusion and provides these perfusion indicators and/or an assessment of the subject's risk of vascular disorders. One perfusion indicator is obtained by measuring the change in pedal arterial circulation volume in a lower limb 12 in response to its elevation H above the subject's heart. Another indicator is obtained by measuring a change in the lower limb 12 flesh tone (colour) in response to its elevation H above the subject's heart.

[0018] The subject lies flat on their back, while a measurement is taken with the subject's lower limb 12 in a non-elevated position and a measurement is taken with the subject's lower limb 12 in an elevated position. Elevation is relative to the subject's heart reference level 3.

[0019] The system 10 comprises a lifting mechanism for raising a subject's leg 2 from the non-elevated position to the elevated position. The leg 2 pivots about the subject's hip 1. The mechanism may be a lifting pulley 7 or alternatively a lifting platform 6.

[0020] The system additionally comprises a blood volume sensor 4 and a control unit 5. The sensor 4 includes a support that fits around the lower limb 12, specifically around the ankle and dorsum of the foot. The sensor 4 may include a strain gauge wrapped around the dorsum or alternatively it may include a light source and light sensors to detect blood volume changes.

[0021] The control unit 5 receives a first input from the sensor when the subject is in a first posture e.g. the foot has a first zero elevation above the subject's heart and a second input from the sensor when the subject is in a second posture e.g. the foot has a second non-zero elevation above the subject's heart. The control unit 5 processes the first and second inputs to quantify the change in arterial blood volume with postural change. This may be used as a quantitative perfusion indicator that indicates the status of arterial blood circulation in the foot 12.

[0022] It may be desirable for the second input to be taken when the subject's foot 12 is at a particular elevation. The lifting mechanism may be calibrated to enable the foot to be manually elevated to the correct height. Alternatively, the lifting mechanism may provide a signal to the control unit 5, which automatically controls the lifting mechanism to stop elevation at a desired height or provides an alert to an operator to stop elevating the foot at the required height.

[0023] Instead of using the lifting mechanism to measure the elevation, it is also possible to use the control unit 5 to estimate the elevation. In this case, an electronic inclinometer would be attached to the subject's lower limb with a correct orientation. It may, for example, be integrated into the sensor 4 or control unit 5. The inclinometer provides an incline

input θ to the control unit 5 which uses a value of the subject's leg length L to estimate the elevation H of the lower limb 12 using trigonometry ($H = L * \tan \theta$). The leg length L may be input into the control unit 5 after direct measurement or may be estimated by the control unit 5 from a value of the subject's height input to the control unit 5. The control unit 4 may additionally either control the rate of change of elevation by controlling the lifting mechanism or may monitor the rate of change of elevation and provide an audio alert if the rate of elevation is too fast or too slow.

[0024] In the illustrated embodiment, the control unit 5 forms part of the sensor support 4, but in other embodiments it may be mounted on the sensor support and directly connected to it or it may be positioned remote from the sensor support 4 and indirectly connected to it e.g. using radio transceivers.

[0025] The control unit 5 may include a user interface including a user input device such as a keyboard and a user output device such as a display. The display may, for example, display the elevation of the lower limb 12, the equivalent hydrostatic pressure for that elevation, a first perfusion indicator dependent upon the pedal arterial circulation volume in the elevated lower limb 12 and a second perfusion indicator dependent upon the flesh tone (colour) of the elevated lower limb.

[0026] Fig. 2 illustrates a system 10 for the objective assessment of blood perfusion in a lower limb 12 of a subject using an optical sensor 4. The Figure illustrates a non-contact embodiment.

[0027] The system 10 comprises a photo-plethysmographic (PPG) 4 sensor, an electronic inclinometer (INC) 14, an optically diffusive skin (ODS) 16 and an electronic control unit (ECU) 5 that includes pre-processing circuitry 60 and an analysis unit (ANU) 56, which may be a microprocessor.

[0028] The PPG sensor 4 illuminates the dorsum of the foot from a range of a few cm. The PPG sensor 4 uses an array of light emitting diodes to provide a diffuse illumination pattern that extends over a significant fraction of the dorsum (approx. 20 sq cm). The optical receiver is located adjacent to the array of photodiodes or is mounted within the array. Light collection optics (reflectors or lenses) can be used to shape the beam pattern and collection aperture.

[0029] The optically diffusive skin (ODS) 16 covers the area of tissue to be illuminated (e.g. dorsum of the foot). The skin may, for example, be made from a polymer material such as latex. The skin 16 functions to reduce in-homogeneity in the optical interaction with the tissue by creating a smooth but diffusive interface between the illuminating light field and the actual skin surface.

[0030] The inclinometer 14 is aligned with the shinbone. The inclinometer 14 registers the angle θ at which the leg 2 is inclined. This value is converted to an elevation and hydrostatic pressure change by the electronic control unit 5. The leg length may be entered directly to the control unit 4 or it may be derived from a look up table based on the subject's height.

[0031] The PPG sensor 4 produces an output voltage that is dependent upon the intensity of the light detected by the sensor. This output voltage is provided to the pre-processing circuitry 60 of the electronic control unit 5 as illustrated in Fig. 3.

[0032] The pre-processing circuitry 60 includes an input node 50, a low pass filter 54, a high pass filter 52, a first analogue to digital converter (ADC) 55, a second analogue to digital converter (ADC) 53 and an amplifier 52.

[0033] The low pass filter 54 and high pass filter 51 are connected in parallel to the input node 50. The low pass filter 54 is connected in series to the first ADC 55 and the high pass filter is connected in series to the amplifier 52 which is connected to the second ADC.

[0034] The low pass filter 54 converts the sensor output 41 into a signal (I_{dc}) that represents the steady-state or slowly varying intensity of the light detected by the PPG sensor 4. This signal is sampled and digitised by the second ADC and then provided to the processor 56.

[0035] The high pass filter 51 converts the sensor output 41 into a signal (I_{ac}) that represents the varying intensity of the light detected by the PPG sensor 4. This signal is amplified by amplifier 52 and it is then sampled and digitised by the second ADC and then provided to the processor 56.

[0036] The low pass filter passes signals with a frequency less than $\sim 1\text{Hz}$ i.e. non-pulsating signals, whereas the high pass filter passes signals with a frequency of greater than $\sim 1\text{Hz}$ i.e. pulsating signals. The high pass signal I_{ac} is therefore representative of the change of intensity caused by arterial pulses in the lower limb 12 of the subject. These cut-off frequencies may have to adapt, in practice, to individual heart rates.

[0037] The processor 56 processes the digitised signals I_{dc} and I_{ac} . It calculates a ratio of ratios R ,

$$R = \frac{I(\theta)_{AC} / I(\theta)_{DC}}{I(0)_{AC} / I(0)_{DC}}$$

where

$I(\theta)_{ac}$ represents the varying intensity of the light detected by the PPG sensor 4 when the subject is in a first posture i.e. the lower limb is elevated with an incline of θ .

$I(\theta)_{dc}$ represents the steady state intensity of the light detected by the PPG sensor 4d when the subject is in a first posture i.e. the lower limb is elevated with an incline of θ .

$I(0)_{ac}$ represents the varying intensity of the light detected by the PPG sensor 4 when the subject is in a second posture i.e. the lower limb is elevated with an incline of 0 (zero).

$I(0)_{dc}$ represents the steady state intensity of the light detected by the PPG sensor 4 when the subject is in a second posture i.e. the lower limb is elevated with an incline of 0 (zero)

R will be unity if the blood volume pulsations remain unchanged as a proportion of the total blood volume when the limb is elevated. The ratio R can be used to categorise the postural response of the circulation system in the lower limb and foot.

[0038] For example, it might be the case that as the lower limb 12 is raised in a healthy arterial system I_{ac} remains approximately constant but changes significantly for an unhealthy arterial system.

[0039] The value R represents a first perfusion indicator and it may be displayed on display 58.

[0040] Fig. 4A illustrates the change in pulsatile perfusion for a healthy subject's leg when raised to 30 degrees. The subject was a 35 year old female. The Fig plots a trace of pulsatile perfusion i.e. I_{AC} / I_{DC} on the Y-axis against time in seconds on the X-axis. The subject's leg is raised from 0 degrees elevation to 30 degrees elevation for 30 seconds between $t=50$ and 80 seconds. The plot of Fig 4A may be displayed contemporaneously on the display 58.

[0041] Fig. 4B illustrates the envelope of the trace in Fig 4A. The plot of Fig 4B may be displayed contemporaneously on the display 58.

[0042] The ratio R may be calculated from the ratio of pulsatile perfusion ($I(\theta)_{ac} / I(\theta)_{dc}$) when $t=60$ and pulsatile perfusion ($I(0)_{ac} / I(0)_{dc}$) when $t=45$. That is the ratio of the pulsatile perfusion soon after, but not immediately after, the leg has been raised to the pulsatile perfusion just before the leg has been raised. The ratio R for this healthy subject is in the region of 2. This indicates increased perfusion when the leg is elevated.

[0043] Fig. 5A illustrates the change in pulsatile perfusion for an at-risk subject's leg when raised to 30 degrees. The subject was a 79 year old diabetic male. The Fig plots a trace of pulsatile perfusion i.e. I_{AC} / I_{DC} on the Y-axis against time in seconds on the X-axis. The subject's leg is raised from 0 degrees elevation to 30 degrees elevation for 30 seconds between $t=50$ and 80 seconds. The plot of Fig 5A may be displayed contemporaneously on the display 58.

[0044] Fig. 5B illustrates the envelope of the trace in Fig 5A. The plot of Fig 5B may be displayed contemporaneously on the display 58.

[0045] The ratio R may be calculated from the ratio of pulsatile perfusion ($I(\theta)_{ac} / I(\theta)_{dc}$) when $t=60$ and pulsatile perfusion ($I(0)_{ac} / I(0)_{dc}$) when $t=45$. That is the ratio of the pulsatile perfusion soon after, but not immediately after, the leg has been raised to the pulsatile perfusion just before the leg has been raised. The ratio R for this at-risk subject is in the region of 1. This indicates no change in perfusion when the leg is elevated.

[0046] The value of R indicates that the subject is at-risk of developing circulatory complications in the foot. In extreme at-risk cases, the value of R may be less than 1.

[0047] A clinically determined threshold value T may be determined, such that when R for a particular subject is below the threshold, they are deemed at risk. This may be detected and displayed on the display 58. The extent of risk may also be calibrated against the difference between the threshold and calculated value of R and a quantitative or qualitative indication of the extent of risk may be displayed on the display 58.

[0048] The total output I of the PPG sensor 4 can be represented as $I_{dc} + I_{ac}$. The value of I is governed to a major extent by the blood volume illuminated and the skin absorption. The effect of skin absorption is removed by the ratio of ratios R.

[0049] Because R is calculated, the actual light intensity used for a particular subject can vary according to what is required to obtain a well-resolved signal. This will be a function of many factors including skin type, thickness, anatomy, probe placement and probe coupling. Adjustment of the light intensity can be performed to optimise the signal acquisition with respect to the dynamic range of measurement.

[0050] The process of objective assessment of blood perfusion in a lower limb 12 of a subject involves the following steps. The subject rests in a supine position and an optically diffusive skin (ODS) 16 is placed over at least the subject's dorsum. The system 10 is then attached to the lower limb 12 using a strap. The approximate height of the subject is entered into the control unit 5 using the keyboard 57. The control unit 5 via the inclinometer 14 registers the base position (i.e. horizontal) and gives green light to proceed via display 58. The lower limb 12 of the subject is slowly raised and then held for a few seconds. The perfusion indicators are calculated and displayed.

[0051] Although the PPG sensor 4 is illustrated in Fig. 2 as a non-contact sensor, in alternative embodiments the sensor 4 may be attached to the lower limb, for example, by using an elasticated strap to hold the sensor 4 and control unit 5 in position during the test. The skin 16 also serves as a disposable hygiene barrier, reducing contamination of the sensors and cross infection between subjects.

[0052] The system 10 illustrated in Figs 2 and 3, may be simply adapted to determined a second perfusion indicator

dependent upon the blanching of the skin tone of the lower limb 12 when it is elevated. This second perfusion indicator may be calculated in addition to or as an alternative to the first perfusion indicator R.

[0053] For example, a discrete spectrometer can be used to analyse the light reflected from the lower limb 12, when it is in the non-elevated position and when it is in the elevated position. The spectrometer can give a quantitative value for the blanching that occurs on elevating the limb.

[0054] As another example, the foot may be illuminated using IR light and also red light.

An IR sensors output may be pre-processed as described with reference to Fig. 3 to produce $I_{dc}[IR]$, $I_{ac}[IR]$. A red light sensor's output may be pre-processed as described with reference to Fig. 3 to produce $I_{dc}[red]$, $I_{ac}[red]$. The processor 56 may calculate a ratio R'_{dc} or R'_{ac}

$$R'_{dc} = (I_{dc}[red](\theta) / (I_{dc}[IR](\theta) + I_{dc}[red](\theta))) / (I_{dc}[red](0) / (I_{dc}[IR](0) + I_{dc}[red](0)))$$

$$R'_{ac} = (I_{ac}[red](\theta) / (I_{ac}[IR](\theta) + I_{ac}[red](\theta))) / (I_{ac}[red](0) / (I_{ac}[IR](0) + I_{ac}[red](0)))$$

[0055] It should be appreciated that embodiments of the invention do not provide a diagnosis but provide an interim clinical indicator that will, for example, help in the assessment of the risks associated with a condition such as diabetes. The indicator indicates that something is wrong with the subject's circulation but not necessarily what is specifically wrong or what disease is the cause.

[0056] The previously described embodiments relate to a change in posture in which the limb at which measurement is made is elevated above the level of the subject's heart. However, more general postural changes are possible. For example, the position of the limb at which measurement is made may be simply changed between the first and second postures. Such a change in position may be by raising the limb or lowering the limb and the limb need not be elevated above the heart level of the subject. Also, a postural change may arise from changing the position of a part of the subject's body at which measurement is not made. For example, the subject may change posture by bending from the torso while the limb at which measurement is made remains stationary.

[0057] Consequently a more general expression of the ratio of ratios R calculated by the processor 56 from the digitised signals I_{dc} and I_{ac} is:

$$R = \frac{I^{(1)}_{AC} / I^{(1)}_{DC}}{I^{(2)}_{AC} / I^{(2)}_{DC}}$$

where

$I^{(1)}_{ac}$ represents the varying intensity of the light detected by the PPG sensor 4 when the subject is in a first posture

$I^{(1)}_{dc}$ represents the steady state intensity of the light detected by the PPG sensor 4 when the subject is in the first posture

$I^{(2)}_{ac}$ represents the varying intensity of the light detected by the PPG sensor 4 when the subject is in a second posture

$I^{(2)}_{dc}$ represents the steady state intensity of the light detected by the PPG sensor 4 when the subject is in a second posture

[0058] Although the preceding embodiments describe the limb at which measurement is made as a foot, the hand, lower arm or lower leg may also be suitable.

[0059] Although embodiments of the present invention have been described in the preceding paragraphs with reference to various examples, it should be appreciated that modifications to the examples given can be made without departing from the scope of the invention as claimed.

[0060] Whilst endeavouring in the foregoing specification to draw attention to those features of the invention believed to be of particular importance it should be understood that the Applicant claims protection in respect of any patentable feature or combination of features hereinbefore referred to and/or shown in the drawings whether or not particular emphasis has been placed thereon.

Claims

1. A system (10) for assessing blood circulation in a subject's limb (12), comprising:

5 detection means (4, 60) for detecting a signal (I_{AC}) dependent upon the arterial blood volume in a limb (12) of the subject when the subject is in a first posture and also when the subject is in a second posture, different to the first posture; and
 10 processing means (56) for calculating a quantitative indicator (R, R') that is dependent upon the ratio of the signal for the first posture ($I(1)_{AC}$) to the signal for the second posture ($I(2)_{AC}$).

2. A system (10) as claimed in claim 1, wherein the quantitative indicator (R, R') is directly proportional to the ratio of the signal for the first posture ($I(1)_{AC}$) to the signal for the second posture ($I(2)_{AC}$).

15 3. A system (10) as claimed in claim 1 or 2, wherein the signal is a pulsating component (I_{AC}) of a measured parameter (I), the measured parameter being dependent upon the blood volume in the subject's limb.

4. A system (10) as claimed in claim 3, wherein the calculation of the quantitative indicator (R, R') is additionally dependent upon the ratio of a non-pulsating component of the measured parameter for the second posture ($I(2)_{DC}$) to a non-pulsating component of the measured parameter for the first posture ($I(1)_{DC}$).
 20

5. A system (10) as claimed in claim 4, wherein the quantitative indicator is directly proportional to the ratio of the non-pulsating component of the measured parameter for the second posture ($I(2)_{DC}$) to the non-pulsating component of the measured parameter for the first posture ($I(1)_{DC}$).
 25

6. A system (10) as claimed in any preceding claim, wherein the detection means (4, 60) comprises measurement means (4) operable to measure a parameter (I) indicative of the blood volume of the subject's limb when the subject is in a first posture and to measure the parameter when the subject is in a second posture and comprising means for isolating (51) a pulsating component (I_{AC}) of the measured parameter.
 30

7. A system (10) as claimed in any preceding claim wherein the limb (12) is a foot.

8. A system as claimed in any preceding claim, wherein the position of the limb (12) is changed between the first posture and the second posture.
 35

9. A system (10) as claimed in any preceding claim, wherein, in the first posture the limb (12) is at a first elevation and in the second posture the limb (12) is at a second elevation.

10. A system (10) as claimed in any one of claims 3 to 9, wherein the measured parameter (I) is the intensity of light reflected from the limb (12) and the ratio of the signal for the first posture to the signal for the second posture reduces subject dependent influences such as variable light absorption of the blood and tissue in the limb for different subjects.
 40

11. A method for assessing blood circulation in a subject's limb (12), comprising:

45 detecting a signal ($I(1)_{AC}$) dependent upon the arterial blood volume in a limb (12) of the subject when the subject is in a first posture;
 detecting the signal ($I(2)_{AC}$) dependent upon the arterial blood volume in the limb of the subject when the subject is in a second posture, different to the first posture; and
 50 calculating a quantitative indicator (R, R') that is dependent upon the ratio of the signal for the first posture ($I(1)_{AC}$) to the signal for the second posture ($I(2)_{AC}$).

12. A method as claimed in claim 11, further comprising:

55 measuring a parameter (I) that is dependent upon the blood volume in the subject's limb (12); and
 isolating, as the signal (I_{AC}), a pulsating component of the measured parameter (I).

13. A method as claimed in claim 12, further comprising:

isolating a non-pulsating component (I_{DC}) of the measured parameter (I), wherein the quantitative indicator is additionally dependent upon the ratio of the non-pulsating component of the measured parameter for the second posture ($I(2)_{DC}$) to the non-pulsating component of the measured parameter for the first posture ($I(1)_{DC}$).

- 5 14. A method as claimed in claim 13, wherein the limb (12) is a foot.
15. A method as claimed In any one of claims 11 to 14, wherein the position of the limb (12) is changed between the first posture and the second posture.
- 10 16. A method as claimed in any one of claims 11 to 15 wherein, in the first posture the limb (12) is at a first elevation and in the second posture the limb (12) is at a second elevation.

Patentansprüche

- 15 1. System (10) zum Beurteilen der Blutzirkulation in einem Glied (12) einer Person, welches aufweist:
- 20 ein Erfassungsmittel (4, 60) zum Erfassen eines Signals (I_{AC}), das von dem arteriellen Blutvolumen in einem Glied (12) der Person abhängig ist, wenn die Person eine erste Haltung einnimmt und auch wenn die Person eine zweite Haltung einnimmt, die sich von der ersten Haltung unterscheidet; und
- ein Verarbeitungsmittel (56) zum Berechnen eines quantitativen Indikators (R, R'), der von dem Verhältnis des Signals für die erste Haltung ($I(1)_{AC}$) und des Signals für die zweite Haltung ($I(2)_{AC}$) abhängig ist.
- 25 2. System (10) nach Anspruch 1, bei welchem der quantitative Indikator (R, R') zu dem Verhältnis des Signals für die erste Haltung ($I(1)_{AC}$) und des Signals für die zweite Haltung ($I(2)_{AC}$) direkt proportional ist.
3. System (10) nach Anspruch 1 oder 2, bei welchem das Signal eine pulsierende Komponente (I_{AC}) eines gemessenen Parameters (I) ist, wobei der gemessene Parameter von dem Blutvolumen in dem Glied der Person abhängig ist.
- 30 4. System (10) nach Anspruch 3, bei welchem die Berechnung des quantitativen Indikators (R, R') außerdem abhängig ist von dem Verhältnis einer nicht-pulsierenden Komponente des gemessenen Parameters für die zweite Haltung ($I(2)_{DC}$) und einer nicht-pulsierenden Komponente des gemessenen Parameters für die erste Haltung ($I(1)_{DC}$).
- 35 5. System (10) nach Anspruch 4, bei welchem der quantitative Indikator zu dem Verhältnis der nicht-pulsierenden Komponente des gemessenen Parameters für die zweite Haltung ($I(2)_{DC}$) und der nicht-pulsierenden Komponente des gemessenen Parameters für die erste Haltung ($I(1)_{DC}$) direkt proportional ist.
- 40 6. System (10) nach einem der vorhergehenden Ansprüche, bei welchem das Erfassungsmittel (4, 60) ein Messmittel (4) aufweist, das betätigbar ist zum Messen eines Parameters (I), der für das Blutvolumen des Gliedes der Person kennzeichnend ist, wenn die Person eine erste Haltung einnimmt, und zum Messen des Parameters, wenn die Person eine zweite Haltung einnimmt, sowie ein Mittel zum Isolieren (51) einer pulsierenden Komponente (I_{AC}) des gemessenen Parameters aufweist.
- 45 7. System (10) nach einem der vorhergehenden Ansprüche, bei welchem das Glied (12) ein Fuß ist.
8. System (10) nach einem der vorhergehenden Ansprüche, bei welchem die Position des Gliedes (12) zwischen der ersten Haltung und der zweiten Haltung gewechselt wird.
- 50 9. System (10) nach einem der vorhergehenden Ansprüche, bei welchem in der ersten Haltung das Glied (12) auf einer ersten Höhe ist und in der zweiten Haltung das Glied (12) auf einer zweiten Höhe ist.
- 55 10. System (10) nach einem der Ansprüche 3 bis 9, bei welchem der gemessene Parameter (I) die Intensität des von dem Glied (12) reflektierten Lichtes ist, und wobei das Verhältnis des Signals für die erste Haltung zu dem Signal für die zweite Haltung von der Person abhängige Einflüsse wie veränderliche Lichtabsorption des Blutes und Gewebes in dem Glied für unterschiedliche Personen verringert.
11. Verfahren zum Beurteilen der Blutzirkulation in einem Glied (12) einer Person, welches die folgenden Schritte aufweist:

EP 1 694 203 B1

Erfassen eines Signals ($I(1)_{AC}$), das von dem arteriellen Blutvolumen in einem Glied (12) der Person abhängig ist, wenn die Person eine erste Haltung einnimmt;

Erfassen des Signals ($I(2)_{AC}$), das von dem arteriellen Blutvolumen in dem Glied der Person abhängig ist, wenn die Person eine zweite Haltung einnimmt, die sich von der ersten Haltung unterscheidet; und

Berechnen eines quantitativen Indikators (R, R'), der von dem Verhältnis des Signals für die erste Haltung ($I(1)_{AC}$) und des Signals für die zweite Haltung ($I(2)_{AC}$) abhängig ist.

12. Verfahren nach Anspruch 11, welches die folgenden weiteren Schritte aufweist:

Messen eines Parameters (I), der von dem Blutvolumen in dem Glied (12) der Person abhängig ist; und Isolieren einer pulsierenden Komponente des gemessenen Parameters (I) als Signal (I_{AC}).

13. Verfahren nach Anspruch 12, welches die folgenden weiteren Schritte aufweist:

Isolieren einer nicht-pulsierenden Komponente (I_{DC}) des gemessenen Parameters (I), wobei der quantitative Indikator zusätzlich abhängig ist von dem Verhältnis der nicht-pulsierenden Komponente des gemessenen Parameters für die zweite Haltung ($I(2)_{DC}$) und der nicht-pulsierenden Komponente des gemessenen Parameters für die erste Haltung ($I(1)_{DC}$).

14. Verfahren nach Anspruch 13, bei welchem das Glied (12) ein Fuß ist.

15. Verfahren nach einem der Ansprüche 11 bis 14, bei welchem die Position des Gliedes (12) zwischen der ersten Haltung und der zweiten Haltung gewechselt wird.

16. Verfahren nach einem der Ansprüche 11 bis 15, bei welchem in der ersten Haltung das Glied (12) auf einer ersten Höhe ist und in der zweiten Haltung das Glied (12) auf einer zweiten Höhe ist.

Revendications

1. Système (10) d'évaluation de la circulation sanguine dans un membre (12) d'un sujet comprenant :

des moyens de détection (4, 60) pour détecter un signal (I_{ac}) dépendant du volume sanguin artériel dans un membre (12) du sujet lorsque le sujet se trouve dans une première posture et également lorsque le sujet se trouve dans une deuxième posture, différente de la première posture ; et

un moyen de traitement (56) pour calculer un indicateur quantitatif (R, R') qui dépend du rapport du signal de la première posture ($I(1)_{AC}$) au signal de la deuxième posture ($I(2)_{AC}$).

2. Système (10) selon la revendication 1, dans lequel l'indicateur quantitatif (R, R') est directement proportionnel au rapport du signal de la première posture ($I(1)_{AC}$) au signal de la deuxième posture ($I(2)_{AC}$).

3. Système (10) selon la revendication 1 ou 2, dans lequel le signal est un composant pulsatoire (I_{AC}) d'un paramètre mesuré (I), le paramètre mesuré étant dépendant du volume sanguin dans le membre du sujet.

4. Système (10) selon la revendication 3, dans lequel le calcul de l'indicateur quantitatif (R, R') est en outre dépendant du rapport d'un composant non pulsatoire du paramètre mesuré pour la deuxième posture ($I(2)_{DC}$) à un composant non pulsatoire du paramètre mesuré pour la première posture ($I(1)_{DC}$).

5. Système (10) selon la revendication 4, dans lequel l'indicateur quantitatif est directement proportionnel au rapport du composant non pulsatoire du paramètre mesuré pour la seconde posture ($I(2)_{DC}$) au composant non pulsatoire du paramètre mesuré pour la première posture ($I(1)_{DC}$).

6. Système (10) selon l'une quelconque des revendications précédentes, dans lequel les moyens de détection (4, 60) comprennent un moyen de mesure (4) pouvant être actionné pour mesurer un paramètre (I) indicatif du volume sanguin du membre du sujet lorsque le sujet se trouve dans une première posture et pour mesurer le paramètre lorsque le sujet se trouve dans une deuxième posture et comprenant un moyen d'isolement (51) d'un composant pulsatoire (I_{AC}) du paramètre mesuré.

7. Système (10) selon l'une quelconque des revendications précédentes, dans lequel le membre (12) est un pied.
8. Système selon l'une quelconque des revendications précédentes, dans lequel la position du membre (12) change entre la première posture et la deuxième posture.
- 5 9. Système (10) selon l'une quelconque des revendications précédentes, dans lequel dans la première posture, le membre (12) se trouve à un premier niveau d'élévation et dans la deuxième posture, le membre (12) se trouve à un deuxième niveau d'élévation.
- 10 10. Système (10) selon l'une quelconque des revendications 3 à 9, dans lequel le paramètre mesuré (I) est l'intensité de la lumière réfléchie du membre (12) et le rapport du signal de la première posture au signal de la deuxième posture réduit les influences dépendantes du sujet telles que l'absorption variable de la lumière du sang et du tissu dans le membre de différents sujets.
- 15 11. Procédé d'évaluation de la circulation sanguine dans un membre d'un patient (12) comprenant :
- la détection d'un signal ($I(1)_{AC}$) dépendant du volume sanguin artériel dans un membre (12) du sujet lorsque le sujet se trouve dans une première posture ;
- 18 la détection du signal ($I(2)_{AC}$) dépendant du volume sanguin artériel dans le membre du sujet lorsque le sujet se trouve dans une deuxième posture, différente de la première posture ; et
- 20 le calcul d'un indicateur quantitatif (R, R') qui est dépendant du rapport du signal de la première posture ($I(1)_{AC}$) au signal de la deuxième posture ($I(2)_{AC}$).
- 25 12. Procédé selon la revendication 11, comprenant en outre :
- la mesure d'un paramètre (I) qui est dépendant du volume sanguin dans le membre du sujet (12) ; et
- l'isolement en tant que signal (I_{AC}) d'un composant pulsatoire du paramètre mesuré (I).
- 30 13. Procédé selon la revendication 12, comprenant en outre :
- l'isolement d'un composant non pulsatoire (I_{DC}) du paramètre mesuré (I), dans lequel l'indicateur quantitatif est en outre dépendant du rapport d'un composant non pulsatoire du paramètre mesuré pour la deuxième posture ($I(2)_{DC}$) à un composant non pulsatoire du paramètre mesuré pour la première posture ($I(1)_{DC}$).
- 35 14. Procédé selon la revendication 13, dans lequel le membre (12) est un pied.
15. Procédé selon l'une quelconque des revendications 11 à 14, dans lequel la position du membre (12) change entre la première posture et la deuxième posture.
- 40 16. Procédé selon l'une quelconque des revendications 11 à 15, dans lequel, dans la première posture, le membre (12) se trouve à un premier niveau d'élévation et dans la deuxième posture, le membre (12) se trouve à un deuxième niveau d'élévation.
- 45
- 50
- 55

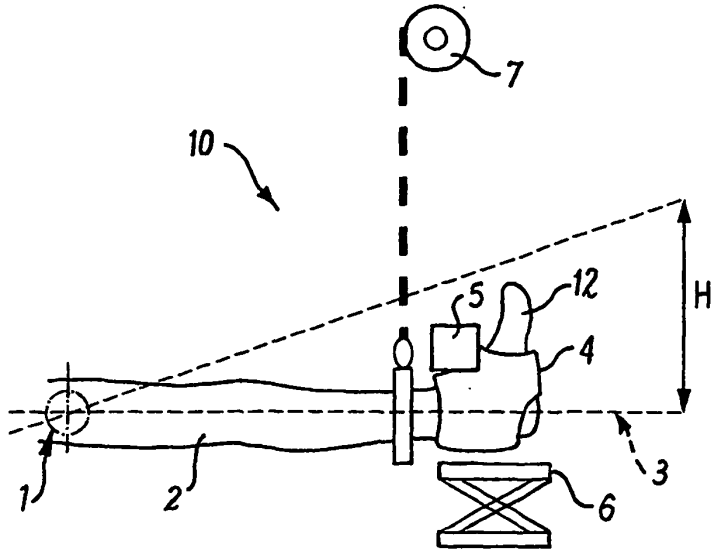

Fig. 1

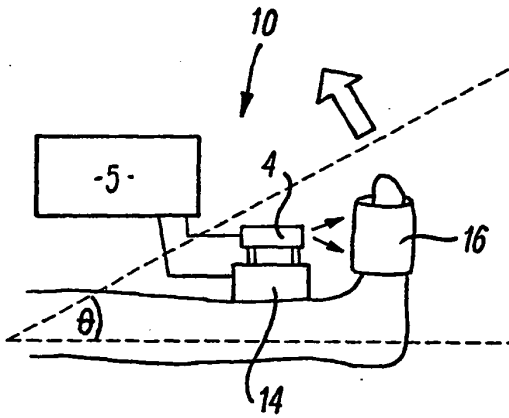

Fig. 2

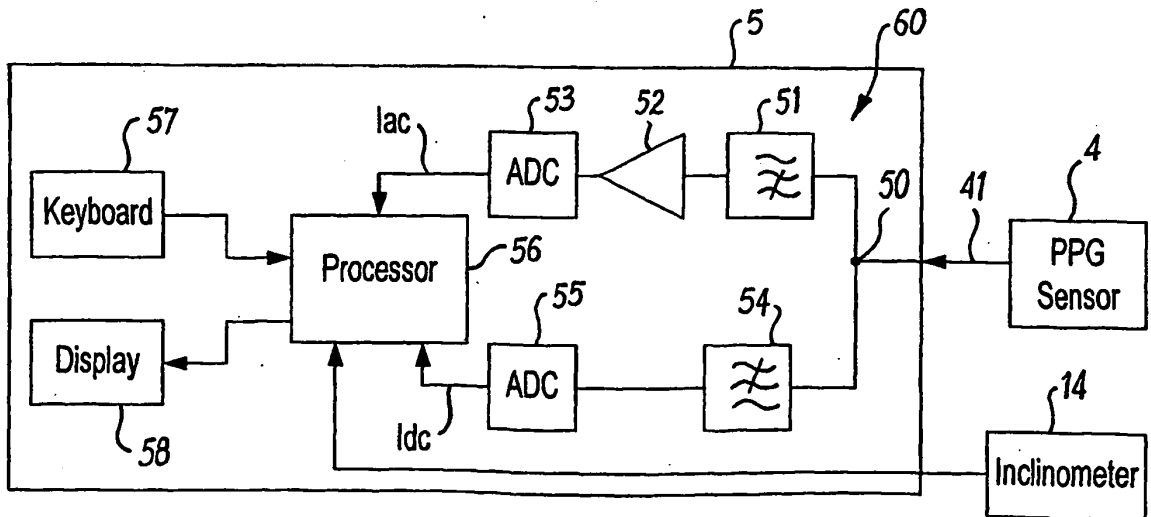

Fig. 3

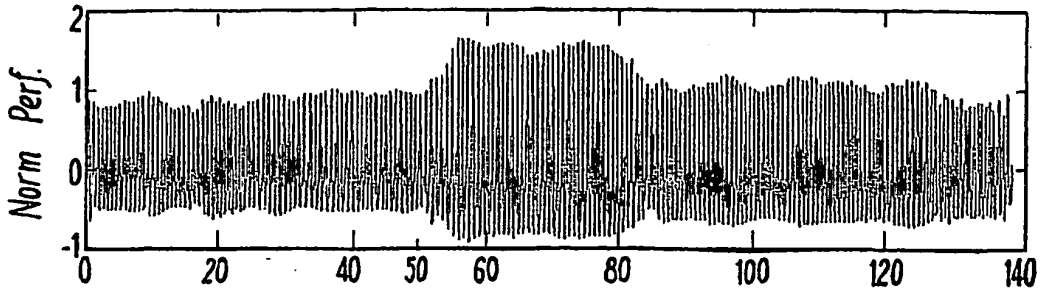

FIG. 4A

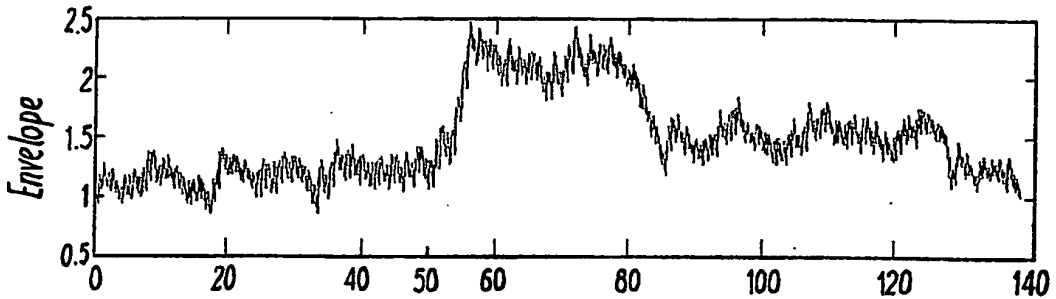

FIG. 4B

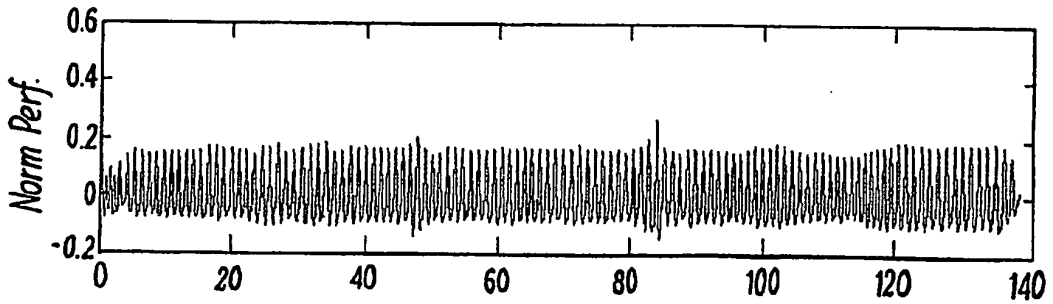

FIG. 5A

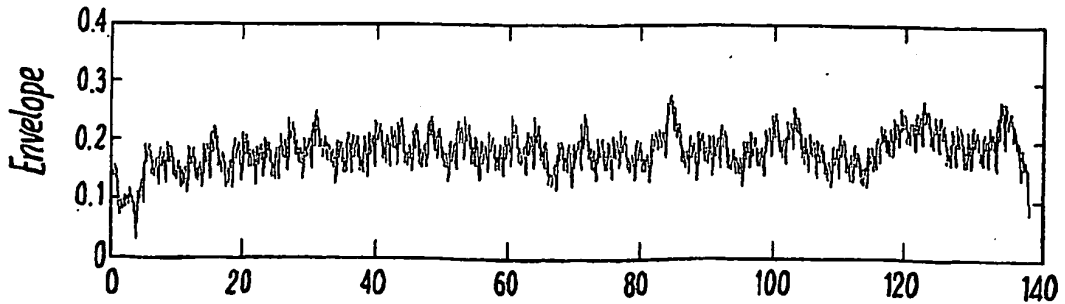

FIG. 5B

REFERENCES CITED IN THE DESCRIPTION

This list of references cited by the applicant is for the reader's convenience only. It does not form part of the European patent document. Even though great care has been taken in compiling the references, errors or omissions cannot be excluded and the EPO disclaims all liability in this regard.

Patent documents cited in the description

- US 5137023 A [0002]
- WO 9817174 A [0002]

专利名称(译)	用于评估受试者的外周血液循环的系统或方法		
公开(公告)号	EP1694203B1	公开(公告)日	2009-08-26
申请号	EP2005701821	申请日	2005-01-10
申请(专利权)人(译)	DIALOG器件有限公司		
当前申请(专利权)人(译)	DIALOG器件有限公司		
[标]发明人	CRABTREE VINCENT PETER SMITH PETER RICHARD		
发明人	CRABTREE, VINCENT, PETER SMITH, PETER RICHARD		
IPC分类号	A61B5/00 A61B5/103		
CPC分类号	A61B5/0261 A61B5/0295 A61B5/6829 A61B5/02		
代理机构(译)	HIGGIN , PAUL		
优先权	2004000281 2004-01-08 GB		
其他公开文献	EP1694203A1		
外部链接	Espacenet		

摘要(译)

一种用于评估受试者肢体中的血液循环的系统，包括：检测装置，用于当受试者处于第一姿势时以及当受试者处于第二姿势时检测取决于受试者肢体中的动脉血容量的信号，与第一种姿势不同；和处理装置，用于计算定量指标，该定量指标取决于第一姿势的信号与第二姿势的信号的比例。

$$R = \frac{I(\theta)_{AC} / I(\theta)_{DC}}{I(0)_{AC} / I(0)_{DC}}$$