



(11) **EP 1 432 375 B1**

(12) **EUROPEAN PATENT SPECIFICATION**

(45) Date of publication and mention of the grant of the patent:
18.03.2009 Bulletin 2009/12

(21) Application number: **02766462.2**

(22) Date of filing: **03.10.2002**

(51) Int Cl.:
A61G 11/00 (2006.01)

(86) International application number:
PCT/US2002/031408

(87) International publication number:
WO 2003/030797 (17.04.2003 Gazette 2003/16)

(54) **PATIENT-SUPPORT APPARATUS HAVING LINE MANAGEMENT SYSTEM**

PATIENTENLIEGEVORRICHTUNG MIT LEITUNGSMANAGEMENTSYSTEM

ENCEINTE DE SOINS A SYSTEME DE GESTION DE TUBES POUR SOINS

(84) Designated Contracting States:
**AT BE BG CH CY CZ DE DK EE ES FI FR GB GR
IE IT LI LU MC NL PT SE SK TR**

(30) Priority: **05.10.2001 US 327496 P**
17.04.2002 US 373417 P

(43) Date of publication of application:
30.06.2004 Bulletin 2004/27

(73) Proprietor: **Draeger Medical Systems, Inc.**
Telford, PA 18969 (US)

(72) Inventor: **MCDERMOTT, Ian**
Lincoln University, PA 19352 (US)

(74) Representative: **Findlay, Alice Rosemary et al**
Reddie & Grose
16 Theobalds Road
London
WC1X 8PL (GB)

(56) References cited:
WO-A-99/12511 **DE-U- 29 709 848**
US-A- 5 308 310 **US-B1- 6 367 476**
US-B1- 6 375 017

EP 1 432 375 B1

Note: Within nine months of the publication of the mention of the grant of the European patent in the European Patent Bulletin, any person may give notice to the European Patent Office of opposition to that patent, in accordance with the Implementing Regulations. Notice of opposition shall not be deemed to have been filed until the opposition fee has been paid. (Art. 99(1) European Patent Convention).

Description

BACKGROUND AND SUMMARY OF THE INVENTION

[0001] The present disclosure relates to a patient-support apparatus, and particularly to a patient-support apparatus having a line management system. More particularly, the present disclosure relates to a patient-support apparatus having a port integrated into an infant enclosure, or in the alternative, a patient-support apparatus having a port integrated into an infant supporting portion.

[0002] Thermal support devices, such as infant warmers and incubators, having an isolation chamber and various systems that maintain the isolation chamber at a controlled temperature and humidity to facilitate the development of a premature infant are known. Infant thermal support devices conventionally include a patient-support surface for supporting the infant in the isolation chamber and a set of side guard panels arranged around the patient-support surface. Many thermal support devices have a canopy over the patient-support surface. The canopy cooperates with the set of side guard panels to enclose the isolation chamber.

[0003] In such support devices, it is common to have a number of lines, both electronic and fluid, which communicate with the infant. These lines are conduits for electric signals, body fluids, oxygen, or any other substance that might be carried or transmitted either toward or away from the infant. At times, it may be desired to remove one line while leaving the remaining lines undisturbed, and it would therefore be advantageous to have the lines arranged and separated in an organized fashion.

[0004] US 5,308,310 discloses a patient-support apparatus comprising a support platform and an infant enclosure coupled to the support platform and defining an infant compartment for receiving an infant, and a line management apparatus configured to separate and manage medical lines routed from between outside and inside the infant compartment, the line management apparatus including a panel extending upwardly relative to the support platform.

[0005] The invention, which is defined in claim 1, provides a patient-support apparatus which is characterized in that the line management apparatus comprises a plurality of vertically spaced plates coupled to and extending in a cantilever manner from the panel and configured to support medical lines resting thereon.

[0006] The infant enclosure preferably includes a side panel extending upwardly from the support platform and the door panel is aligned in side-by-side relation with the side panel when the door panel is in the first position. An end panel is also coupled to the support platform. A gap is defined between the door panel and the end panel when the door panel is in the first position, and each of the medical lines supported on the plates extends through the gap.

[0007] The infant enclosure further includes a canopy

situated above the infant compartment. The canopy has a bottom edge, and the door panel has a top edge that confronts the bottom edge of the canopy when the door panel is in the first position.

[0008] The illustrative plurality of line holders comprises a plurality of flexible fingers that engage the medical lines. The plurality of flexible fingers is grouped into pairs, each pair being associated with a respective one of the plurality of line supports. The flexible fingers of each pair extend away from the panel and have a distal end spaced apart from the panel. A slot is defined between the distal ends of each pair of flexible fingers, and the medical lines are inserted through the slots to be retained by the flexible fingers.

[0009] Additional features will become apparent to those skilled in the art upon consideration of the following detailed description of preferred embodiments exemplifying the best mode of carrying out the patient-support apparatus having a line management system as presently perceived.

BRIEF DESCRIPTION OF THE DRAWINGS

[0010] The detailed description particularly refers to the accompanying figures in which:

Fig. 1 is a perspective view of a patient-support apparatus according to the present disclosure showing a base, a patient support carried above the base, and an isolation chamber enclosed by an overlying canopy, a pair of transparent side guard panels, and a pair of transparent end panels, and further showing a line port having an access door;

Fig. 2 is an enlarged perspective view of the line port and access door of Fig. 1, showing the line port positioned adjacent one end of a side guard panel, and showing the line port having a vertical panel or wall, a plurality of horizontally extending line supports coupled to the panel, and a plurality of line holders coupled to the panel; and

Fig. 3 is an enlarged perspective view of the line port and access door, similar to that of Fig. 2, showing an alternative embodiment having a movable line port wall.

DETAILED DESCRIPTION OF THE DRAWINGS

[0011] A patient-support apparatus 10, such as an infant warming device or incubator, illustratively includes a base 12, a plurality of casters 14 extending downwardly from the base 12, and an infant supporting portion or patient support 16 supported above base 12 as shown in Fig. 1. Illustrative patient support 16 includes a pedestal 18 coupled to base 12 for vertical movement, a platform tub 20 supported by pedestal 18, a platform cover 22 coupled to platform tub 20, and a mattress 24 supported on platform tub 20. Mattress 24 has an upwardly facing patient-support surface 26.

[0012] Patient-support apparatus 10 also includes a canopy support arm 28 including a telescoping vertical arm 30 and a horizontal overhead arm 32. A canopy 34 is coupled to overhead arm 32 and is positioned to lie above platform tub 20. Canopy 34 includes a pair of canopy halves 36 coupled to overhead arm 32 for pivoting movement between a lowered position shown in Fig. 1 and a raised position (not shown).

[0013] A pair of transparent side guard panels 38 and a pair of transparent end guard panels 40 extend upwardly from platform tub 20 as shown in Fig. 1. Side guard panels 38 and end guard panels 40 cooperate with canopy halves 36 and overhead arm 32 to provide patient-support apparatus 10 with an isolation chamber. Side guard panels 38 are illustratively formed to include a pair of access ports 42, as shown in Fig. 1.

[0014] According to the present disclosure, patient-support apparatus 10 further includes a line management system as disclosed herein. In one embodiment, the line management system includes a line port 44, as shown in Fig. 1 and in more detail in Figs. 2 and 3.

[0015] The line port 44 illustrated in Fig. 2 is positioned adjacent one end of side guard panel 38. Port 44 has a line port wall 46 that extends from end guard panel 40. Illustratively, line port wall 46 extends from edge 48 of end guard panel 40 at an angle 50 relative to end guard panel 40. Angle 50 is illustratively an acute angle that positions line port wall 46 such that a vertically extending slot or space is formed between inner edge 52 and side guard panel 38, the slot being wide enough to allow the passage of lines 54 therethrough.

[0016] Another embodiment is shown in Fig. 3, wherein line port wall 46' is hingedly connected for movement relative to end guard panel 40. Such a configuration allows line port wall 46' to pivot about a horizontal axis 56 relative to end guard panel 40, thereby moving inner edge 52 either closer to or farther away from side guard panel 38. In operation, a caregiver inserts medical lines 54 into the appropriate places on line port wall 46', and then pivotably moves line port wall 46' closer toward side guard panel 38 so that the slot between inner edge 52 and side guard panel 38 is minimized.

[0017] As shown in Figs. 2-3, line port 44 comprises line port walls 46, 46', a plurality of plates or line supports 58, and a plurality of line holders 60. Line supports 58 have top surfaces 62 that support respective lines 54, thereby organizing and arranging the lines 54 that are routed into the isolation chamber of patient-support apparatus 10. Line supports 58 extend substantially orthogonally from line port wall 46, 46'. In some embodiments, supports 58 are formed integrally with line port wall 46, 46' and in other embodiments, supports 58 are separate pieces that couple to wall 46, 46'. Although illustrative supports 58 are plate-like elements, it is within the scope of this disclosure for other structures, such as posts, tabs, hooks, fingers, and the like, as well as grooves, channels, or recesses formed in wall 46, 46', to be used as line supports. As a result, the term "line support" as used in

this disclosure, including in the claims, is intended to broadly cover all of these structures and the equivalents thereof.

[0018] Illustratively, each line holder 60 is in horizontal alignment and associated with a respective line support 58. Line holders 60 are illustratively C-shaped clamps or pairs of closely spaced fingers made of a resilient material that is pliable so that lines 54 can be inserted therebetween. However, it is within the scope of the disclosure to utilize any method of retaining lines 54 proximate to line port wall 46, 46'. For example, line holders including hook-and-loop straps, hooks, straps with snaps, latches, clasps, clamps, and the like are within the scope of this disclosure. As a result, the term "line holder" as used in this disclosure, including in the claims, is intended to broadly cover all of these structures and the equivalents thereof.

[0019] It should be understood that the disclosure also anticipates that line supports 58 and line holders 60 need not be used together, but could be used individually. For example, only one of line holders 60 or line supports 58 could be coupled to line port walls 46, 46', and still provide at least some arrangement to lines 54 leading into the isolation chamber of patient-support apparatus 10.

[0020] Illustratively, a door 64 is coupled to platform cover 22 for pivotable movement relative to the platform cover 22. As shown in Figs. 2-3, door 64 is coupled to platform cover 22 with hinges 66. Door 64 moves about a horizontal axis between an open horizontal position, shown in Figs. 2-3, and a closed vertical position, shown in Fig. 1. In the closed position, door 64 is in side-by-side relation with side panel 38, and door 64 limits the amount of air that can exchange between the atmosphere and the patient-support apparatus by substantially covering line port 44. In the illustrated embodiment, a gap or passageway (not shown) is formed between edge 48 and door 64 when door 64 is in the closed position. The passageway permits the passage of lines 54 between edge 48 and door 64 without displacement of door 64 into a non-closed position, and without compression of lines 54. When door 64 is in the closed position; top edge 65 of door 64 is configured to confront or be positioned proximate to bottom edge 67 of canopy 34, as shown in Fig. 1.

[0021] Each of line supports 58 is illustratively formed such that a first end 68 contacts door 64 when door 64 is in the closed position. Such contact prevents lines 54 from being inadvertently moved to another line support 58 when door 64 is in the closed position.

[0022] While the disclosure is susceptible to various modifications and alternative forms, specific exemplary embodiments thereof have been shown by way of example in the drawings and have herein been described in detail. It should be understood, however, that there is no intent to limit the disclosure to the particular forms disclosed.

[0023] There is a plurality of advantages of the present invention arising from the various features of the line management system and associated method described

herein. It will be noted that alternative embodiments of the line management system may not include all of the features described yet still benefit from at least some of the advantages of such features.

Claims

1. A patient-support apparatus (10) comprising a support platform and an infant enclosure coupled to the support platform and defining an infant compartment for receiving an infant, and a line management apparatus configured to separate and manage medical lines (54) routed from between outside and inside the infant compartment, the line management apparatus including a panel (46) extending upwardly relative to the support platform, **characterized in that** the line management apparatus comprises a plurality of vertically spaced plates (58) coupled to and extending in a cantilever manner from the panel (46) and configured to support medical lines (54) resting thereon.
2. The patient-support apparatus of claim 1, wherein the infant enclosure comprises a door panel (64), each plate (58) of the plurality of plates has an edge that faces away from the panel (46), and the door panel (64) is pivotable about an axis relative to the support platform between a first position covering the edges, and a second position uncovering the edges.
3. The patient-support apparatus of claim 2, wherein the axis is a horizontal axis.
4. The patient-support apparatus of each of claim 3 or claim 4, wherein the door panel 64 is oriented substantially vertically when in the first position and the door panel is oriented substantially horizontally when in the second position.
5. The patient-support apparatus of any one of claims 2 to 4, wherein the infant enclosure comprises a side panel (38) extending upwardly from the support platform and the door panel (64) is aligned in side-by-side relation with the side panel (38) when the door panel (64) is in the first position.
6. The patient-support apparatus of any one of claims 2 to 5, wherein the infant enclosure comprises an end panel (40) coupled to the support platform, a gap is defined between the door panel (64) and the end panel (40) when the door panel (64) is in the first position, and each of the medical lines (54) supported on the plates (58) extends through the gap.
7. The patient-support apparatus of any one of claims 2 to 6, wherein the infant enclosure comprises a can-

opy (34) situated above the infant compartment, the canopy (34) has a bottom edge (67), and the door panel (64) has a top edge (65) that confronts the bottom edge (67) of the canopy (34) when the door panel (64) is in the first position.

5

10

15

20

25

30

35

40

45

50

55

8. The patient-support apparatus of any preceding claim, wherein the panel (46) is pivotable relative to the support platform about an axis.
9. The patient-support apparatus of claim 8, wherein the axis is vertical.
10. The patient-support apparatus of either claim 8 or claim 9, wherein infant enclosure comprises a guard panel (40) extending upwardly from the support platform and the panel (46) is pivotably coupled to the guard panel (40).
11. The patient-support apparatus of any preceding claim, further comprising a plurality of line holders (60) coupled to the panel (46) and configured to inhibit movement of the medical lines off of the plates (58).
12. The patient-support apparatus of claim 11, wherein the plurality of line holders comprises a plurality of flexible fingers (60) that engage the medical lines.
13. The patient-support apparatus of claim 12, wherein the plurality of flexible fingers (60) are grouped into pairs, each pair being associated with a respective one of the plurality of plates (58).
14. The patient-support apparatus of claim 13, wherein the flexible fingers (60) of each pair extends away from the panel (46) and has a distal end spaced apart from the panel (46), a slot is defined between the distal ends of each pair of flexible fingers (60), and the medical lines (54) are inserted through the slots to be retained by the flexible fingers (60).
15. The patient-support apparatus of any preceding claim, wherein the plates (58) are configured to extend substantially parallel to a top surface of the infant enclosure.

Patentansprüche

1. Patientenunterstützungsapparat (10), der eine Liegeplattform und ein Säuglingsgehäuse, gekoppelt an die Liegeplattform umfasst, und eine Säuglingskammer zur Aufnahme eines Säuglings definiert, und ein Leitungsmanagementsystem, das zum Separieren und Handhaben medizinischer Leitungen (54) konfiguriert ist, die zwischen der Außen- und Innenseite der Säuglingskammer geführt sind, wo-

- bei das Leitungsmanagementsystem ein Paneel (46) einschließt, das sich relativ zur Liegeplattform nach oben erstreckt, **dadurch gekennzeichnet, dass** das Leitungsmanagementsystem eine Vielzahl von vertikal mit Zwischenraum dazwischen angeordneten Platten (58) umfasst, die an das Paneel (46) gekoppelt sind und sich in einer überhängenden Weise von ihm erstrecken und zum Haltern der darauf ruhenden medizinischen Leitungen (54) konfiguriert sind.
2. Patientenunterstützungsapparat nach Anspruch 1, worin das Säuglingsgehäuse eine Türfüllung (64) umfasst, jede Platte (58) von der Vielzahl von Platten eine Kante aufweist, die vom Paneel (46) wegsieht, und die Türfüllung (64) um eine Achse relativ zur Liegeplattform zwischen einer ersten die Kanten bedeckenden Position und einer zweiten die Kanten freilegenden Position schwenkbar ist.
 3. Patientenunterstützungsapparat nach Anspruch 2, worin die Achse eine Horizontalachse darstellt.
 4. Patientenunterstützungsapparat nach jedem von Anspruch 3 oder 4, worin die Türfüllung 64 im Wesentlichen vertikal ausgerichtet ist, wenn sie sich in der ersten Position befindet und die Türfüllung im Wesentlichen horizontal ausgerichtet ist, wenn sie sich in der zweiten Position befindet.
 5. Patientenunterstützungsapparat nach einem der Ansprüche 2 bis 4, worin das Säuglingsgehäuse ein Seitenpaneel (38) besitzt, das sich von der Liegeplattform nach oben erstreckt und die Türfüllung (64) in einer Seite-an-Seite-Relation mit dem Seitenpaneel (38) bündig abgeschlossen ist, wenn sich die Türfüllung (64) in der ersten Position befindet.
 6. Patientenunterstützungsapparat nach einem der Ansprüche 2 bis 5, worin das Säuglingsgehäuse ein Endpaneel (40), gekoppelt an die Liegeplattform umfasst, ein Spalt zwischen der Türfüllung (64) und dem Endpaneel (40) definiert ist, wenn sich die Türfüllung (64) in der ersten Position befindet, und jede der medizinischen Leitungen (54), die auf den Platten (58) gehalten wird, sich durch den Spalt erstreckt.
 7. Patientenunterstützungsapparat nach einem der Ansprüche 2 bis 6, worin das Säuglingsgehäuse eine Gehäusehaube (34) umfasst, die sich über der Säuglingskammer befindet, wobei die Gehäusehaube (34) eine untere Kante (67) aufweist, und die Türfüllung (64) eine obere Kante (65) aufweist, welche mit der unteren Kante (67) der Gehäusehaube (34) in Kontakt kommt, wenn sich die Türfüllung (64) in der ersten Position befindet.
 8. Patientenunterstützungsapparat nach einem der vorangehenden Ansprüche, worin das Paneel (46) relativ zur Liegeplattform um eine Achse herum schwenkbar ist.
 9. Patientenunterstützungsapparat nach Anspruch 8, worin die Achse vertikal verläuft.
 10. Patientenunterstützungsapparat nach entweder Anspruch 8 oder 9, worin das Säuglingsgehäuse ein Schutzpaneel (40) umfasst, das sich von der Liegeplattform nach oben erstreckt und das Paneel (46) schwenkbar an das Schutzpaneel (40) gekoppelt ist.
 11. Patientenunterstützungsapparat nach einem der vorangehenden Ansprüche, der weiter eine Vielzahl von Leitungshalterungen (60), gekoppelt an das Paneel (46) umfasst und konfiguriert ist, um das Abrutschen der medizinischen Leitungen von den Platten (58) zu unterbinden.
 12. Patientenunterstützungsapparat nach Anspruch 11, worin die Vielzahl der Leitungshalterungen eine Vielzahl flexibler Finger (60) umfasst, welche die medizinischen Leitungen in Eingriff bringt.
 13. Patientenunterstützungsapparat nach Anspruch 12, worin die Vielzahl flexibler Finger (60) in Paaren gruppiert ist, wobei jedes Paar mit einer entsprechenden von einer der Vielzahl von Platten (58) in Verbindung steht.
 14. Patientenunterstützungsapparat nach Anspruch 13, worin sich die flexiblen Finger (60) von jedem Paar vom Paneel (46) weg erstrecken und ein distales Ende aufweisen, das mit Zwischenraum vom Paneel (46) angeordnet ist, ein Schlitz zwischen den distalen Enden von jedem Paar flexibler Finger (60) definiert ist und die medizinischen Leitungen (54) durch die Schlitze insertiert werden, um von den flexiblen Fingern (60) zurückgehalten zu werden.
 15. Patientenunterstützungsapparat nach einem der vorangehenden Ansprüche, worin die Platten (58) konfiguriert sind, um sich im Wesentlichen parallel zur Oberseite des Säuglingsgehäuses zu erstrecken.

Revendications

1. Appareil de survie du patient (10) comprenant une plate-forme de support et un habitacle infantile couplée à la plate-forme de support et définissant un compartiment infantile destiné à recevoir un nourrisson, et un appareil de gestion des tubulaires configuré pour séparer et gérer les tubulaires à médicaments (54) acheminées entre l'extérieur et l'intérieur du compartiment infantile, ledit appareil de gestion

- des tubulures incluant un panneau (46) se rabattant vers le haut relativement à la plate-forme de support, **caractérisé en ce que** ledit appareil de gestion des tubulures comprend une pluralité de plaques (58) espacées sur le plan vertical, couplées à et se déployant d'une manière en cantilever à partir du panneau (46) et configurées de façon à supporter les tubulures à médicaments (54) reposant sur ces dernières.
2. Appareil de survie du patient selon la revendication 1, dans lequel l'habitacle infantile comprend un panneau ouvrable (64), chaque plaque (58) de la pluralité des plaques ayant un bord tourné du côté opposé à celui du panneau (46), et le panneau ouvrable (64) pouvant pivoter autour d'un axe relativement à la plate-forme de support entre une première position couvrant les bords, et une seconde position découvrant les bords.
 3. Appareil de survie du patient selon la revendication 2, dans lequel l'axe est un axe horizontal.
 4. Appareil de survie du patient, selon la revendication 3 ou la revendication 4, dans lequel le panneau ouvrable (64) est orienté en grande partie à la verticale quand il se trouve dans la première position et le panneau ouvrable est orienté en grande partie à l'horizontale quand il se trouve dans la seconde position.
 5. Appareil de survie du patient selon l'une quelconque des revendications 2 à 4, dans lequel l'habitacle infantile comprend un panneau latéral (38) se rabattant vers le haut à partir de la plate-forme de support, et le panneau ouvrable (64) est aligné côte à côte avec le panneau latéral (38) quand le panneau ouvrable (64) se trouve dans la première position.
 6. Appareil de survie du patient selon l'une quelconque des revendications 2 à 5, dans lequel l'habitacle infantile comprend un panneau terminal (40) couplé à la plate-forme de support, un espace est défini entre le panneau ouvrable (64) et le panneau terminal (40) quand le panneau ouvrable (64) se trouve dans la première position, et chacune des tubulures à médicaments (54) prenant appui sur les plaques (58) se prolonge au travers de l'espace.
 7. Appareil de survie du patient selon l'une quelconque des revendications 2 à 6, dans lequel l'habitacle infantile comprend un couvercle (34) situé au-dessus du compartiment infantile, ledit couvercle (34) possède un bord inférieur (67), et le panneau ouvrable (64) possède un bord supérieur (65) qui affronte le bord inférieur (67) du couvercle (34) quand le panneau ouvrable (64) se trouve dans la première position.
 8. Appareil de survie du patient selon l'une quelconque des revendications précédentes, dans lequel le panneau (46) peut pivoter relativement à la plate-forme de support autour d'un axe.
 9. Appareil de survie du patient selon la revendication 8, dans lequel l'axe est vertical.
 10. Appareil de survie du patient selon la revendication 8 ou la revendication 9, dans lequel l'habitacle infantile comprend un panneau de garde (40) se rabattant vers le haut à partir de la plate-forme de support et le panneau (46) est couplé au panneau de garde (40) de manière à ce qu'il puisse pivoter.
 11. Appareil de survie du patient selon l'une quelconque des revendications précédentes, comprenant en outre une pluralité de porte-tubulures (60) couplés au panneau (46) et configurés de manière à empêcher aux tubulures à médicaments de sortir des plaques (58).
 12. Appareil de survie du patient selon la revendication 11, dans lequel la pluralité de porte-tubulures comprend une pluralité de doigts flexibles (60) qui s'engagent sur les tubulures à médicaments.
 13. Appareil de survie du patient selon la revendication 12, dans lequel la pluralité de doigts flexibles (60) sont groupés en paires, chaque paire étant associée à l'une respective de la pluralité de plaques (58).
 14. Appareil de survie du patient selon la revendication 13, dans lequel les doigts flexibles (60) de chaque paire s'éloignent du panneau (46) et possède une extrémité distale située à un certain intervalle du panneau (46), une fente est définie entre les extrémités distales de chaque paire de doigts flexibles (60), et les tubulures à médicaments (54) sont introduites dans les fentes pour y être retenues par les doigts flexibles (60).
 15. Appareil de survie du patient selon l'une quelconque des revendications précédentes, dans lequel les plaques (58) sont configurées de manière à s'étendre en grande partie parallèlement à une surface supérieure de l'habitacle infantile.

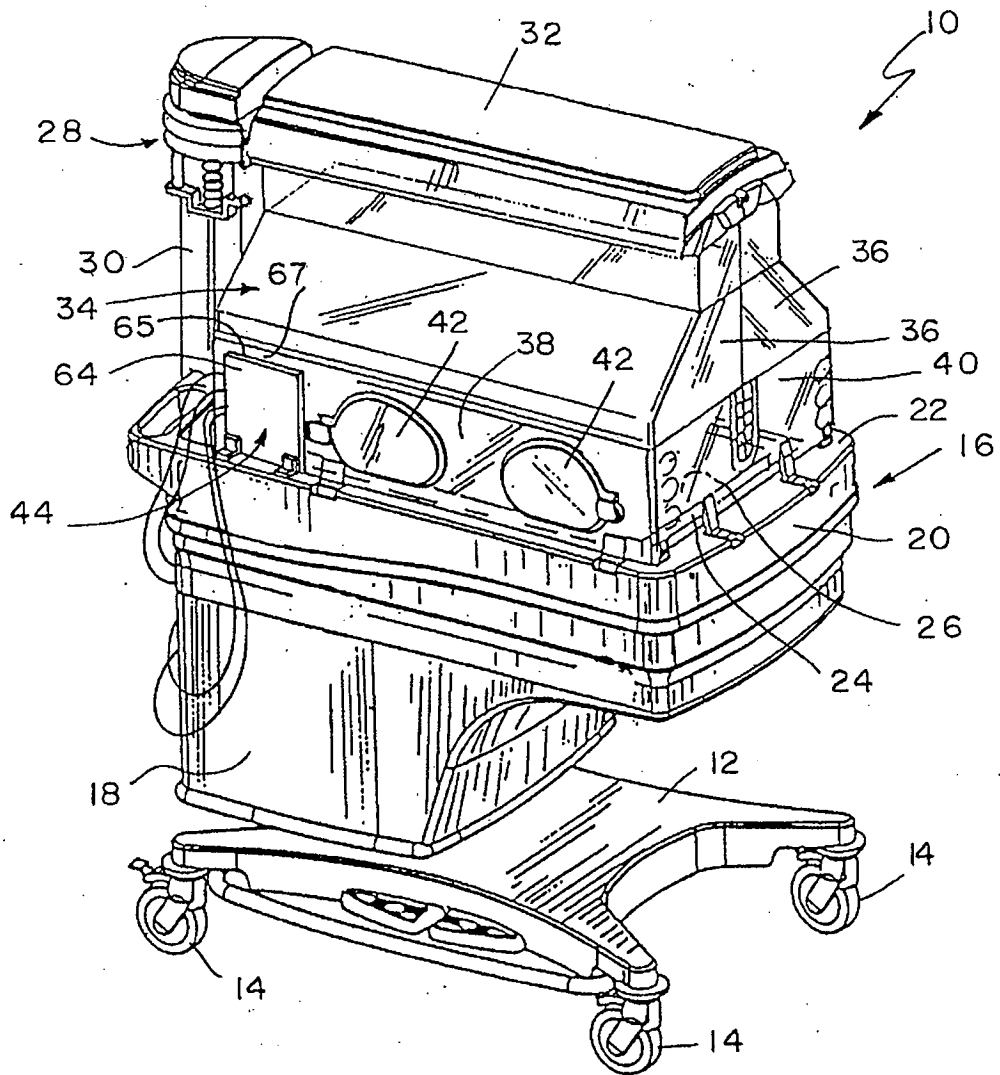

FIG. 1

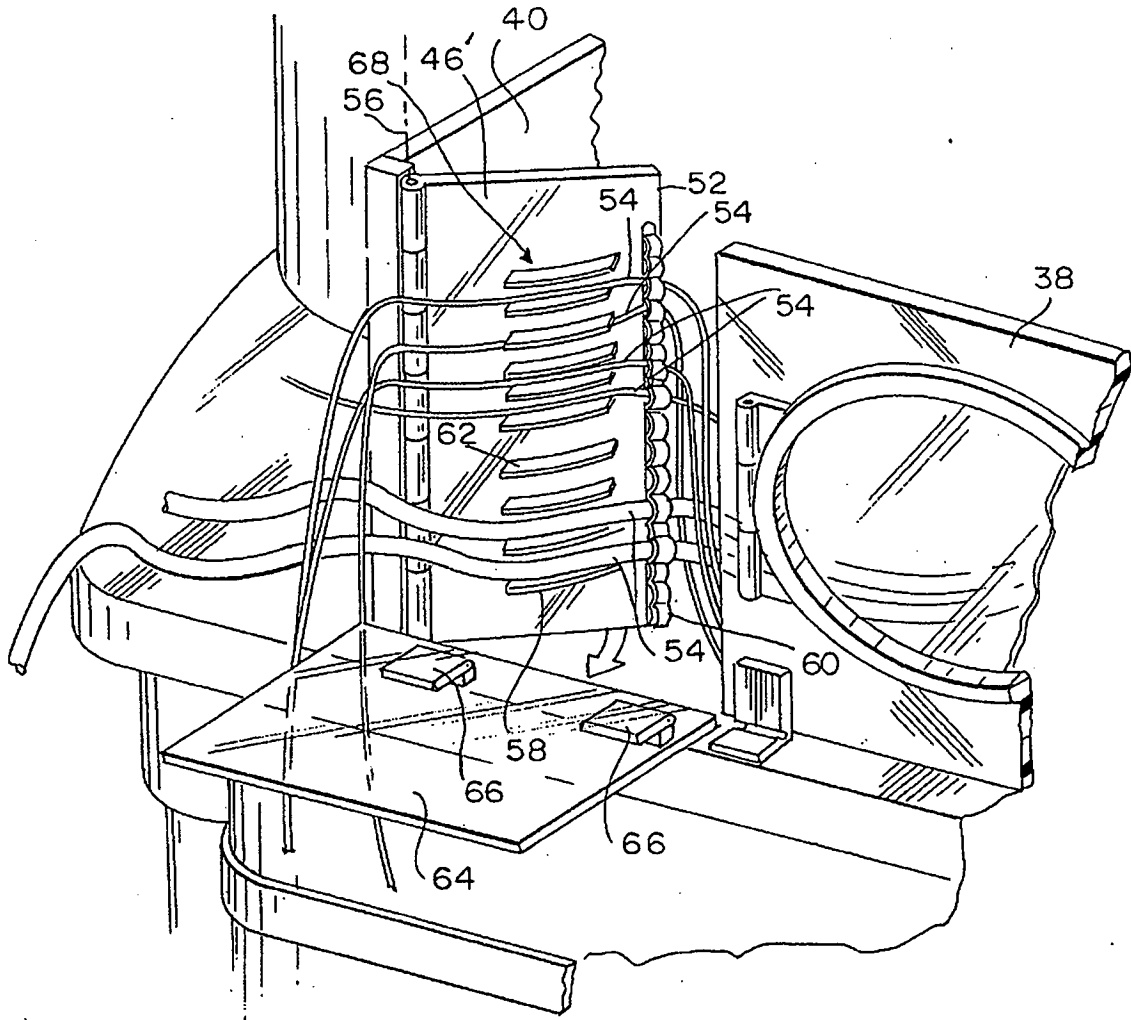

FIG. 3

REFERENCES CITED IN THE DESCRIPTION

This list of references cited by the applicant is for the reader's convenience only. It does not form part of the European patent document. Even though great care has been taken in compiling the references, errors or omissions cannot be excluded and the EPO disclaims all liability in this regard.

Patent documents cited in the description

- US 5308310 A [0004]

专利名称(译)	患者支持设备具有线路管理系统		
公开(公告)号	EP1432375B1	公开(公告)日	2009-03-18
申请号	EP2002766462	申请日	2002-10-03
[标]申请(专利权)人(译)	希尔 - 罗姆服务股份有限公司		
申请(专利权)人(译)	HILL-ROM SERVICES , INC.		
当前申请(专利权)人(译)	德尔格医疗系统公司.		
[标]发明人	MCDERMOTT IAN		
发明人	MCDERMOTT, IAN		
IPC分类号	A61G11/00 A61B5/00 A61B5/0205 A61B5/021 A61B5/024 A61B5/08 A61G7/05 A61M5/14 G06F19/00		
CPC分类号	A61G12/002 A61B5/0002 A61B5/0205 A61B5/02055 A61B5/021 A61B5/024 A61B5/0816 A61B5/1455 A61B5/6892 A61B5/742 A61B5/7435 A61B2560/0242 A61B2560/0443 A61B2562/222 A61G7/0503 A61G11/00 A61G11/002 A61G11/005 A61G11/009 A61G2203/80 A61M5/1418 G06F19/321 G06F19/3481 G16H40/63		
优先权	60/373417 2002-04-17 US 60/327496 2001-10-05 US		
其他公开文献	EP1432375A2		
外部链接	Espacenet		

摘要(译)

提供一种婴儿支撑装置 (10) , 其包括支撑平台 (26) , 连接到支撑平台 (26) 并限定用于接收婴儿 (78) 的婴儿隔间的婴儿外壳 (34) 和线路管理装置被配置成分开和布置在婴儿隔间的外侧和婴儿隔间的内部之间布线的医疗线 (54) 。线路管理装置的一个实施例包括相对于支撑平台 (26) 向上延伸的面板 (46) , 多个垂直间隔的线支撑 (58) , 其连接到面板 (46) 并配置成支撑医疗线 (54) 搁置在其上, 并且多个线保持器 (60) 连接到面板 (46) 并且构造成阻止医疗线 (54) 离开线支撑件 (58) 。

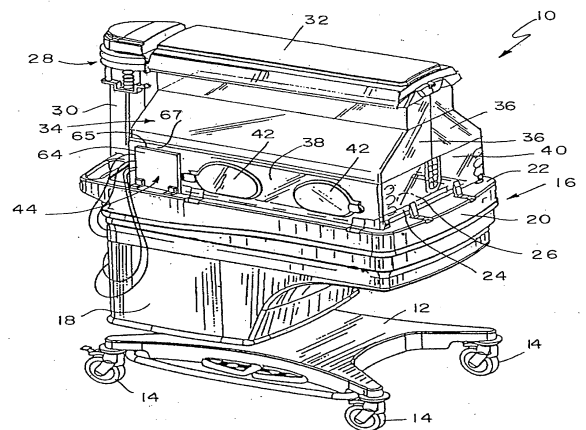

FIG. 1