

(19)



(11)

EP 1 342 448 B1

(12)

EUROPEAN PATENT SPECIFICATION

(45) Date of publication and mention of the grant of the patent:
01.05.2013 Bulletin 2013/18

(51) Int Cl.:
A61B 5/145 (2006.01)

(21) Application number: **03003247.8**

(22) Date of filing: **24.02.2003**

(54) **Minimum invasive optical format with integrated lance**

Minimal-invasives optisches Format mit integrierter Lanze

Format optique pour la chirurgie mini-invasive avec une lance intégrée

(84) Designated Contracting States:
AT BE BG CH CY CZ DE DK EE ES FI FR GB GR HU IE IT LI LU MC NL PT SE SI SK TR

(72) Inventor: **Dosmann, Andrew, J. Granger, Indiana 46530 (US)**

(30) Priority: **05.03.2002 US 361401 P**

(74) Representative: **Linhart, Angela Bayer HealthCare AG Law and Patents, Patents and Licensing 51368 Leverkusen (DE)**

(43) Date of publication of application:
10.09.2003 Bulletin 2003/37

(60) Divisional application:
10183150.1 / 2 269 510

(56) References cited:
EP-A- 0 447 726 DE-A- 3 708 031 US-A- 2 830 587 US-A- 6 041 246

(73) Proprietor: **Bayer HealthCare LLC Tarrytown, New York 10591 (US)**

EP 1 342 448 B1

Note: Within nine months of the publication of the mention of the grant of the European patent in the European Patent Bulletin, any person may give notice to the European Patent Office of opposition to that patent, in accordance with the Implementing Regulations. Notice of opposition shall not be deemed to have been filed until the opposition fee has been paid. (Art. 99(1) European Patent Convention).

Description**FIELD OF THE INVENTION**

[0001] The present invention relates to minimum invasive techniques to determine compositions of body fluids. More particularly, the present invention relates to an optical format with a square fused silica lance for piercing skin of a user to harvest blood for testing.

BACKGROUND OF THE INVENTION

[0002] Current methods of monitoring components of body fluids such as blood glucose involve painful skin punctures using steel needles having diameters from 28 (360 μm) to 24 (550 μm) gauge. Approximately thirty percent of steel lance skin punctures do not produce a blood sample thus requiring repeated puncturing. This increases the pain experienced by a patient causing some patients to avoid or skip testing. In order for prior art to conduct a proper analysis of a body fluid sample, a patient must lance and then manually harvest a minimum of 300 nL of body fluid such as blood into a format or a strip. An electrochemical or optical analysis of a chemical reaction is then performed to determine the levels of the desired component.

[0003] EP 044 7 726 A1 discloses body portion and a translucent needle portion projecting therefrom. US 5801057 A1 and US 2001/0001034 A1 each disclose a device for optical analysis of body fluids.

SUMMARY OF THE INVENTION

[0004] The present invention is directed to a lance and optical format that can puncture the skin of a patient with little resulting pain, significantly improve reliability of blood production, automatically harvest a small blood sample, and analyze the sample with conventional transmission spectrometry. The lance is defined by a square, fused silica capillary tube. One end of the tube is cleaved to a sharp point that serves to pierce the skin of a patient. The other end of the lance is secured in a housing that has windows or aligned openings defining an optical path.

[0005] A blood sample is produced by first piercing a patient's skin followed by either vacuum or mechanical pressure around the wound to enhance blood flow. The lance is returned to a drop of blood at the puncture and the sample is harvested. Capillary action draws the sample into the lance. The sample reacts with reagents coated onto the walls inside the capillary, which produces a color change to the sample. Optical analysis of the sample can be performed using transmission spectrometry by passing a beam of light through the lance to a detector.

BRIEF DESCRIPTION OF THE FIGURES

[0006] Other objects and advantages of the invention

will become apparent upon reading the following detailed description and upon reference to the drawings in which:

FIG. 1 is a perspective view of a minimum invasive optical format with an integrated lance constructed in accordance with the principles of the present invention;

FIG. 2 is a cross sectional view of the minimum invasive optical format with an integrated lance taken along line 2-2 of FIG. 3; and

FIG. 3 is a top plan view of the minimum invasive optical format with an integrated lance taken along line 3-3 of FIG. 2.

DETAILED DESCRIPTION OF THE ILLUSTRATED EMBODIMENTS

[0007] Referring to the drawings, a minimum invasive optical format with an integrated lance generally designated by the reference numeral 10 is illustrated. The format with integrated lance 10 includes a lance 12 formed from a square fused silica capillary tubing manufactured by Polymicro Technologies of Phoenix, Arizona. The lance 12 can have other shapes such as rectangular depending on the intended use of the format with integrated lance 10.

[0008] The lance 12 is hollow and has a square channel 13 which can have a width of 50 μm , 75 μm or 100 μm and a length of 5 mm. These dimensions correspond to volumes of 13 nl, 29 nl, and 50 nl, respectively. A chemistry or reagent indicator 22 is dried onto an inside wall 24 of the channel 13. The chemistry 22 has an indicator formulation that is sensitive to an analyte being read. For example, if the analyte is glucose, the chemistry could be reductive hexokinase or glucose dehydrogenase. A first end 14 of the lance 12 is cleaved to a sharp point 16 at an angle of $45^\circ \pm 15^\circ$ that serves to pierce the skin of a patient. The sharp point 16 at an angle of $45^\circ \pm 15^\circ$ aids in cleanly cutting the skin as well as blood capillaries below the skin. Cutting blood capillaries improves the reliability of producing a blood sample to 98%.

[0009] To minimize pain when skin is pierced by the sharp point 16 of the lance 12, it is preferred that the outside dimension of the lance 12 be small. By using a square fused silica tube for the lance 12, the outside dimension of the lance 12 is 300 μm which is smaller than a similar dimension of a typical 28 gauge steel lance which has a diameter of 360 μm . Lance 10 can be modified depending on the intended use.

[0010] The format with integrated lance 10 also includes a housing 18 mounted on a second end 20 of the lance 12. The housing 18 has opposed windows or openings 19. The housing 18 controls the depth of a puncture into a patient's skin by the lance 12. The depth of a puncture corresponds to the length of the lance 12 extending out of the housing 18. In one embodiment, the portion of the lance 12 extending outside of the housing 18 measures 2 mm. The housing 18 also provides support for the

lance 12 and resists breakage of the lance 12. Breakage of the lance 12, however, is minimized due to the strength of fused silica which is based on a Si-O bond which has a theoretical tensile strength of 2000 kpsi.

[0011] The optical format with integrated lance 10 is used to pierce the skin of a patient with the sharp point 16. Once a drop of blood appears at the puncture site, the tip or first end 14 of the lance 12 is returned to the drop of blood and capillary action draws a sample into the square channel 13. Another embodiment would leave the lance below the surface of the skin until capillary action or vacuum assisted capillary action obtains a sample. The sample is allowed to react with the dried chemistry 22 coated onto the capillary walls which produces a color change to the sample. The change in color is proportional to analyte concentration. The sample is then read with transmission spectrometry by passing a monochromatic collimated beam of light through the portion of the lance 12 in the housing 18 by passing the beam through one of the openings 19 in the housing 18. The opening 19 can be used to mask the beam down to only the sample area in the lance 12. A detector is located adjacent the other opening 19. The flat surfaces of the lance 12 provide an excellent optical window and the optical transmission of fused silica is spectrally flat from UV into infrared. Thus, readings can be done at several wavelengths to correct for interferences. For example, hematocrit levels in whole blood can interfere with glucose concentration determination. Hamatocrit could be determined at a wavelength that is independent of glucose. Glucose concentration can then be corrected. In addition, the square shape of the capillary 12 provides a two times increase in transverse optical interaction path length compared to round capillaries. The square shape of the lance 12 also provides alignment between the openings 19 in the housing 18 and the sample in the lance 12.

Claims

1. A device (10) for the optical analysis of body fluids, comprising a lance (12) defined by a multisided tube wherein each side is planar and of a material that allows transmission of light, a housing (18) mounted around a portion of said lance (12), said housing (18) including openings (19) for passage of light through said housing (18) and said portion of said tube.
2. The device claimed in claim 1 wherein said tube is square.
3. The device claimed in claim 1 wherein said tube is rectangular.
4. The device claimed in one of the claims 1 to 3 wherein said tube includes a first end (14), said first end (14)

being cleaved to a sharp point (16) for piercing skin.

5. The device claimed in one of the claims 1 to 4 comprising a reagent (22) on an inside surface (24) of said tube.
6. The device claimed in one of the claims 1 to 5 wherein said material is fused silica.
7. A method for making a device (10) for the optical analysis of body fluids comprising:
 - forming a square capillary tube of fused silica; cleaving a first end (14) of said tube to form a sharp point (16); and
 - securing a housing (18) around a portion of said tube adjacent to a second end (20) of said tube, said housing (18) including openings (19) for passage of light through said housing (18) and said portion of said tube.

Patentansprüche

1. Vorrichtung (10) für die optische Analyse von Körperflüssigkeiten mit einer Lanzette (12), die durch eine Röhre mit mehreren Seiten definiert ist, wobei jede Seite planar ist und aus einem Material besteht, das den Durchgang von Licht gestattet, einem Gehäuse (18), das um einen Abschnitt der Lanzette (12) montiert ist, wobei das Gehäuse (18) Öffnungen (19) zum Durchgang von Licht durch das Gehäuse (18) und den Abschnitt der Röhre aufweist.
2. Vorrichtung nach Anspruch 1, wobei die Röhre quadratisch ist.
3. Vorrichtung nach Anspruch 1, wobei die Röhre rechteckig ist.
4. Vorrichtung nach einem der Ansprüche 1 bis 3, wobei die Röhre ein erstes Ende (14) aufweist, das zu einer scharfen Spitze (16) zum Durchstechen von Haut zugespitzt ist.
5. Vorrichtung nach einem der Ansprüche 1 bis 4, mit einem Reagens (22) an einer Innenfläche (24) der Röhre.
6. Vorrichtung nach einem der Ansprüche 1 bis 5, wobei das Material Quarzglas ist.
7. Verfahren zur Herstellung einer Vorrichtung (10) für die optische Analyse von Körperflüssigkeiten mit folgenden Schritten:

Bilden einer quadratischen Kapillarröhre aus Quarzglas,
 Zuspitzen eines ersten Endes (14) der Röhre zur Bildung einer scharfen Spitze (16) und Befestigen eines Gehäuses (18) um einen Abschnitt der Röhre in der Nähe eines zweiten Endes (20) der Röhre, wobei das Gehäuse (18) Öffnungen (19) zum Durchgang von Licht durch das Gehäuse (18) und den Abschnitt der Röhre aufweist.

5
 10

Revendications

1. Dispositif (10) pour l'analyse optique de liquides biologiques, comprenant une lance (12) définie par un tube à plusieurs côtés, chaque côté étant plan et dans un matériau qui permet la transmission de la lumière, un boîtier (18) monté autour d'une partie de ladite lance (12), ledit boîtier (18) comportant des ouvertures (19) pour le passage de la lumière à travers ledit boîtier (18) et ladite partie dudit tube. 15
20
2. Dispositif selon la revendication 1 dans lequel ledit tube est carré. 25
3. Dispositif selon la revendication 1 dans lequel ledit tube est rectangulaire. 30
4. Dispositif selon l'une des revendications 1 à 3 dans lequel ledit tube comprend une première extrémité (14), ladite première extrémité (14) étant clivée en un point tranchant (16) pour percer la peau. 35
5. Dispositif selon l'une des revendications 1 à 4 comprenant un réactif (22) sur une surface intérieure (24) dudit tube. 40
6. Dispositif selon l'une des revendications 1 à 5 dans lequel ledit matériau est la silice fondue.
7. Procédé de fabrication d'un dispositif (10) pour l'analyse optique de liquides biologiques, comprenant : 45
 - la formation d'un tube capillaire carré de silice fondue ;
 - le clivage d'une première extrémité (14) dudit tube pour former un point tranchant (16) ; et 50
 - la fixation d'un boîtier (18) autour d'une partie dudit tube au voisinage d'une deuxième extrémité (20) dudit tube, ledit boîtier (18) comportant des ouvertures (19) pour le passage de la lumière à travers ledit boîtier (18) et ladite partie dudit tube. 55

Fig. 1

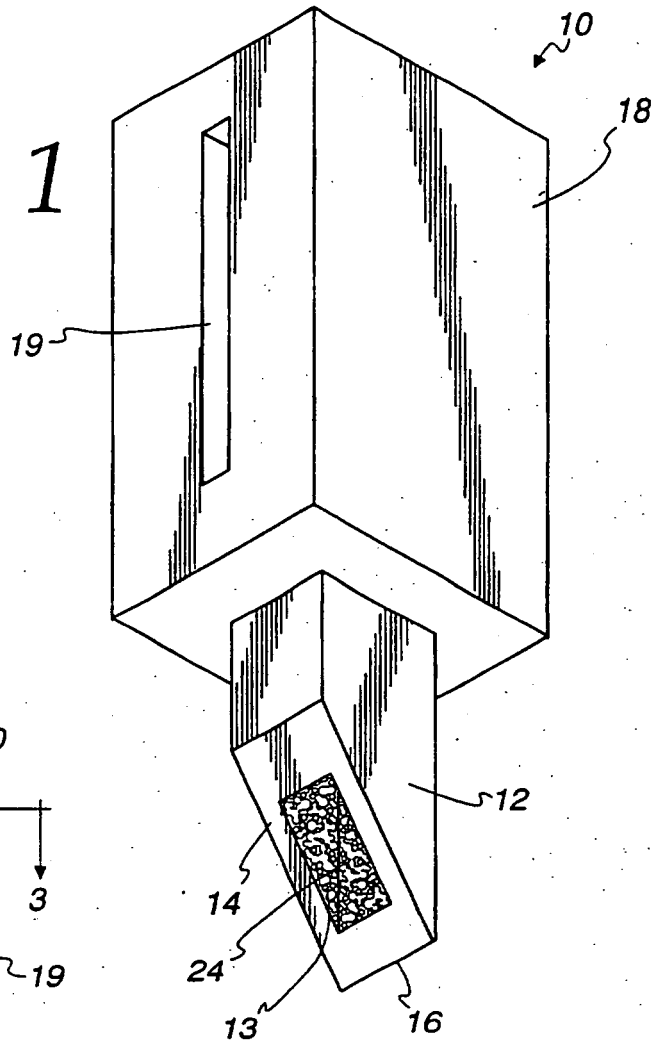

Fig. 2

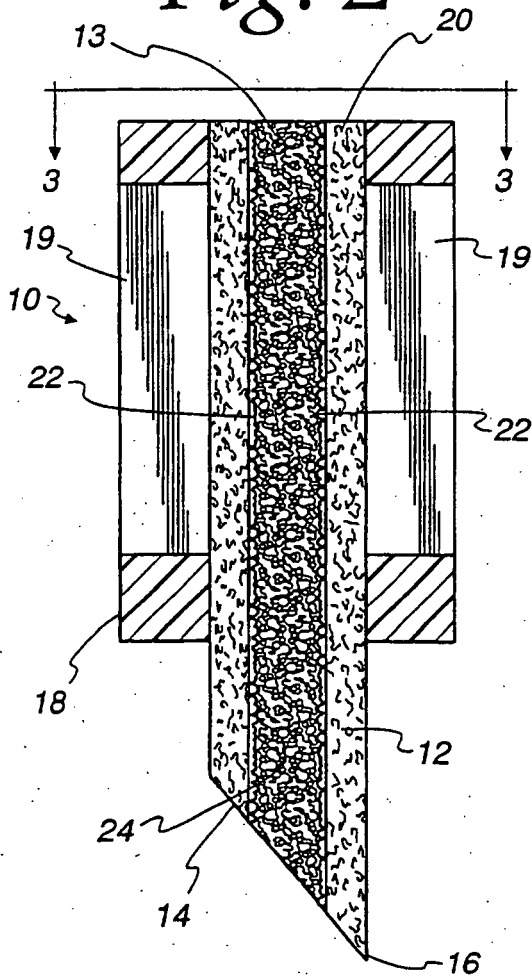
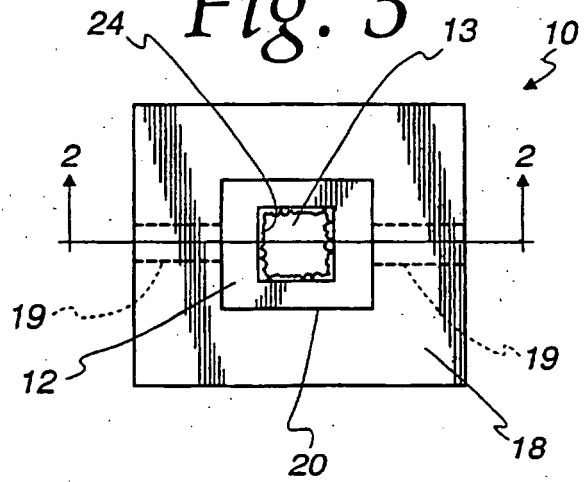

Fig. 3



REFERENCES CITED IN THE DESCRIPTION

This list of references cited by the applicant is for the reader's convenience only. It does not form part of the European patent document. Even though great care has been taken in compiling the references, errors or omissions cannot be excluded and the EPO disclaims all liability in this regard.

Patent documents cited in the description

- EP 0447726 A1 [0003]
- US 5801057 A1 [0003]
- US 20010001034 A1 [0003]

专利名称(译)	具有集成喷枪的微创光学格式		
公开(公告)号	EP1342448B1	公开(公告)日	2013-05-01
申请号	EP2003003247	申请日	2003-02-24
[标]申请(专利权)人(译)	拜尔健康护理有限责任公司		
申请(专利权)人(译)	拜耳医药保健, LLC		
当前申请(专利权)人(译)	拜耳医药保健有限责任公司		
[标]发明人	DOSMANN ANDREW J		
发明人	DOSMANN, ANDREW, J.		
IPC分类号	A61B5/145 A61B5/151 A61B5/00 A61B5/1459 A61B5/15 A61B5/157		
CPC分类号	A61B5/14532 A61B5/1455 A61B5/14557 A61B5/1486 A61B5/150022 A61B5/150389 A61B5/150511 A61B5/150519 A61B5/150755 A61B5/15134 A61B5/6848		
优先权	60/361401 2002-03-05 US		
其他公开文献	EP1342448A1		
外部链接	Espacenet		

摘要(译)

用于刺穿患者皮肤并采集血液以确定血液化学物质(例如葡萄糖水平)的一次性光学形式包括具有限定光学路径的开口的壳体。半透明的中空毛细管安装在壳体中,所述半透明的中空毛细管具有多个平面侧面和切割成锋利边缘的端部。管的侧面由诸如熔融石英的光学材料形成。通过整合喷枪,收获和分析操作,实现了显着更少的疼痛,高采血概率和改善的总体测试时间。

