

(19)



(11)

EP 3 274 671 B1

(12)

EUROPEAN PATENT SPECIFICATION

(45) Date of publication and mention of the grant of the patent:
23.10.2019 Bulletin 2019/43

(51) Int Cl.:
G01J 1/04^(2006.01) A61B 5/00^(2006.01)
A61B 90/00^(2016.01)

(21) Application number: **16767594.1**

(86) International application number:
PCT/CA2016/050341

(22) Date of filing: **23.03.2016**

(87) International publication number:
WO 2016/149827 (29.09.2016 Gazette 2016/39)

(54) **NEAR INFRARED LIGHT OPTICAL IMAGING DEVICE COMPRISING CAP**

NAH-INFRAROTLICHT OPTISCHE BILDGEBUNGSVORRICHTUNG UMFASST EINE KAPPE
 DISPOSITIF D'IMAGERIE OPTIQUE DE LUMIERE PROCHE INFRAROUGE COMPRENANT UN CAPUCHON

(84) Designated Contracting States:
AL AT BE BG CH CY CZ DE DK EE ES FI FR GB GR HR HU IE IS IT LI LT LU LV MC MK MT NL NO PL PT RO RS SE SI SK SM TR

- **HENDERSON, James Patrick**
 Gatineau, Québec J9H 1E2 (CA)
- **RILEY, Jason David Richard**
 Kingston, Ontario K7K 2Z6 (CA)

(30) Priority: **23.03.2015 US 201562136781 P**

(74) Representative: **f & e patent**
Braunsberger Feld 29
51429 Bergisch Gladbach (DE)

(43) Date of publication of application:
31.01.2018 Bulletin 2018/05

(73) Proprietor: **Archeoptix Biomedical Inc.**
Kingston, Ontario K7M 4W6 (CA)

- (56) References cited:
- | | |
|----------------------------|----------------------------|
| WO-A1-2006/097910 | WO-A1-2011/084480 |
| WO-A2-2006/121833 | WO-A2-2006/121833 |
| US-A1- 2011 046 491 | US-A1- 2013 085 356 |
| US-A1- 2013 090 541 | US-A1- 2013 090 541 |
| US-A1- 2014 243 681 | US-B2- 8 527 035 |

(72) Inventors:
 • **STRATIS, Savvas**
Kingston, Ontario K7M 2B4 (CA)

Note: Within nine months of the publication of the mention of the grant of the European patent in the European Patent Bulletin, any person may give notice to the European Patent Office of opposition to that patent, in accordance with the Implementing Regulations. Notice of opposition shall not be deemed to have been filed until the opposition fee has been paid. (Art. 99(1) European Patent Convention).

EP 3 274 671 B1

Description

FIELD OF THE INVENTION

[0001] The present invention pertains to the field of optical imaging and in particular to devices for optical imaging to detect hematoma.

BACKGROUND

[0002] A hematoma is a localized collection of extravasated blood (e.g., blood from a ruptured blood vessel or the like), usually clotted, in an organ, space, or tissue; bruises and black eyes are familiar forms that are seldom serious. Hematomas can occur almost anywhere on the body including inside the skull, and are almost always present with a fracture; in minor injuries the blood is absorbed unless infection develops.

[0003] Hematomas inside the skull are particularly serious, because they can produce local pressure on the brain. The two most common kinds of these are epidural (outside the brain and its fibrous covering, the dura, but under the skull) and subdural (between the brain and its dura). Other types of hematomas occurring inside the skull include intracerebral (in the brain tissue) and subarachnoid (around the surfaces of the brain, between the dura and arachnoid membranes). Such hematomas can result from a number of causes such as head injury or head trauma as well as due to bleeding disorders or an aneurysm.

[0004] Subdural hematomas are usually the result of serious head injury. When a subdural hematoma occurs this way, it is typically called an acute subdural hematoma. Acute subdural hematomas are among the deadliest of head injuries as the bleeding fills the brain area very rapidly, thereby compressing brain tissue, which can lead to brain injury.

[0005] Subdural hematomas also can occur from a minor head injury, especially when the injured is elderly. Such hematomas can go unnoticed for a long period of time (e.g., many days to weeks) and are often called a chronic subdural hematoma. With any subdural hematoma, tiny veins between the surface of the brain and its dura stretch and tear, allowing blood to collect. In the elderly, such veins are often stretched because of brain atrophy or shrinkage and thus are more easily injured.

[0006] Because of the negative consequences associated with hematomas inside the head or skull, it is necessary to be able to identify and locate such hematomas inside the skull, such that appropriate medical and surgical procedures (e.g., evacuation of the hematoma) can be timely undertaken so as to reduce the chances for mortality and/or worsened outcome in survivors. Such timely undertaking is on the order of about 4 hours from occurrence of the injury and the evacuation of the hematoma.

[0007] The standard of care for detecting and imaging hematomas in traumatic head injury is either computed

tomography (CT) scanning or magnetic resonance imaging (MRI). Acute hematomas represent the largest cause of death from head injury, with a mortality rate of 50-60%. Mortality rate can be lowered by diagnosis and treatment within the "golden hour" following traumatic head injury. However, CT and MRI are downstream technologies employed at large medical centers; accordingly, the time from injury to diagnosis is usually at least an hour, followed by subsequent treatment outside of the golden hour.

[0008] Chronic bleeds are often continuously monitored to check for evolution of the bleed. A secondary concern is the increasing belief that the number of CT scans in general needs to be reduced, particularly in pediatric populations, to reduce radiation exposure. Repeated CT is the method of choice to monitor chronic hematoma, which is a common form of Traumatic Brain Injury (TBI) in the pediatric population.

[0009] Although CT scanning and MRI are imaging techniques that can be used to identify and locate traumatic intracranial hematomas, all medical facilities (e.g., trauma centers) do not necessarily have immediate CT scanning and MRI capability on a 24/7 basis and thus it may not be possible in such cases for such scans to be performed so that an identified hematoma can be evacuated within the desired time frame. Also, timely identification of patients that require surgery for dealing with the hematoma can be more difficult in emergencies involving head trauma in underdeveloped areas of the world, or in areas which have limited access to trauma centers having 24/7 CT scanning or MRI capability or which have travel time issues from the site of the injury to the treatment facility, e.g., a rural area or a battlefield.

[0010] In such settings where a CT scan cannot be performed within the desired time frame, the primary method for identification of patients with hematomas is by means of a neurological exam. A neurological exam, however, is a poor substitute for a CT scan because no single physical sign can reliably indicate the presence of a hematoma. Focal neurological findings are found in only a fraction of patients with surgical hematomas. Coma has been reported to occur without the occurrence of a surgical hematoma in a large percentage of patients with severe head injury. Although patients with an intracranial hematoma will exhibit increased intracranial pressure (ICP), edema of the optic disk (papilledema), associated with ICP, is uncommon after head injury.

[0011] Even if the type of hematomas cannot be determined with certainty, the presence of any type of hematoma is the only information required in the field to triage a patient immediately to a hospital with neurosurgical diagnostic and operative capabilities.

[0012] It is therefore desirable to provide a device that would allow a clinician, medical personnel, emergency medical technician, field medic or the like to detect such a hematoma without requiring the use of imaging systems or techniques such as CT scan or MRI systems and in a wide range of settings including hospital ER settings

and usage in the battlefield, rural areas or in less developed areas of the world.

[0013] There exist imaging technologies that utilize the Near Infra-Red (NIR) spectrum for detecting hematoma; examples are described in WO 2006/121833 and WO 2011/084480.

[0014] WO 2006/121833 discloses a system and method for determining a brain hematoma including a handheld device for emitting and detecting radiation with a removable light guide assembly. The method for determining a brain hematoma condition includes determining optical density of various regions of the brain using near infrared spectroscopy. In the above identified publication, the described device is positioned at a specific location of the head and data is acquired using the device. After acquiring data at this location, the device is re-located to another location of the head and another set of data is acquired at the new location. This relocation of the device and acquiring a set of data is repeated until the device has been placed at all possible or desired locations of the head.

[0015] WO 2011/084480 discloses methods, apparatus and devices for detecting a hematoma in tissue of a patient. In one aspect, such a method includes emitting near infrared light continuously into the tissue from a non-stationary near infrared light emitter and continuously monitoring the tissue using a non-stationary probe so as to continuously detect reflected light. The near infrared light is emitted at two distances from a brain of the patient, so the emitted light penetrates to two different depths. Such a method also includes applying a ratiometric analysis to the reflected light to distinguish a border between normal tissue and tissue exhibiting blood accumulation.

[0016] Diamond, in US 2011/046491, disclosed an optode for use in a functional IR diffuse optical neuroimaging system, the optode comprising a GRIN lens inserted into an elastomeric grommet that is attached to an elastomeric cap worn by the subject, wherein the GRIN lens is placed in contact with the scalp of a subject during imaging.

[0017] Schlottau *et al.*, in US 2013/085356, disclosed sensor systems for applying pressure to a patient's tissue that optionally include pressure application devices such as inflatable, deformable, or expandable structures, e.g., inflatable bladders or expanding foams, and/or bendable structures, such as metal strips, to facilitate improved tissue-sensor contact.

[0018] While these technologies allow for detection of hematoma using handheld devices, there remains a need for technologies that are suitable for use on uneven surfaces, while also effectively excluding ambient light infiltration, thereby resulting in an improved signal-to-noise ratio.

[0019] This background information is provided to reveal information believed by the applicant to be of possible relevance to the present invention. No admission is necessarily intended, nor should be construed, that any of the preceding information constitutes prior art

against the present invention.

SUMMARY OF THE INVENTION

[0020] An object of the present invention is to provide a near infrared (NIR) light optical imaging device according to independent claim 1. The invention is defined solely by the appended claims.

BRIEF DESCRIPTION OF THE FIGURES

[0021]

FIG 1A is a perspective view of an optical imaging device in accordance with an embodiment of the present invention.

FIG 1B is an end view of an optical imaging device in accordance with an embodiment of the present invention.

FIG 2A is a cross sectional side view of an optical imaging device in accordance with an embodiment of the present invention.

FIG 2B is an exploded side view of an optical imaging device in accordance with an embodiment of the present invention

FIG 3 is a bottom view of a removable cap in accordance with one embodiment of the present invention.

FIG 4 is a perspective view of a removable cap in accordance with one embodiment of the present invention.

FIG 5 is an exploded view of a removable cap in accordance with one embodiment of the present invention.

FIG 6 is a cross sectional view of a removable cap in accordance with one embodiment of the present invention.

FIGS 7A-C illustrate perspective, front and back views of an optical imaging device in accordance with an embodiment of the present invention.

FIG 8 is an exploded view of an optical imaging device in accordance with an embodiment of the present invention.

FIG 9 is a top perspective view of a base plate in accordance with one embodiment of the present invention.

FIG 10 is a bottom perspective view of the base plate of Figure 9.

FIG 11 is a perspective view of a bellow support plate in accordance with one embodiment of the present invention.

FIG 12A is top a top view of the bellow support plate of FIG 11, and FIG 12B is a bottom view of the bellow support plate of FIG 11.

FIG 13 is a perspective view of a bellow in accordance with one embodiment of the present invention.

FIG 14 is a perspective view of a removable cap in accordance with one embodiment of the present invention.

FIG 15 is a cut-through view of a removable cap in accordance with one embodiment of the present invention.

FIG 16 is an exploded view of a removable cap in accordance with one embodiment of the present invention.

FIG 17 is a perspective view of a removable cap assembled with a base plate in accordance with one embodiment of the present invention.

FIG 18 is a perspective view of an optical imaging device in accordance with an embodiment of the present invention, with the removable cap attached.

FIG 19 is a perspective view of an optical imaging device in accordance with an embodiment of the present invention, with the removable cap removed.

FIG 20 is an exploded view of an optical imaging device in accordance with an embodiment of the present invention.

DETAILED DESCRIPTION OF THE INVENTION

Definitions

[0022] The terms "intracranial bleeding" and "intracranial hematoma" are intended to be used interchangeably, and encompass any accumulation of blood inside the skull of the patient, including the following: epidural hematoma, subdural hematoma, intracerebral hematoma, subarachnoid hematoma, and unilateral and bilateral hematoma.

[0023] An "epidural hematoma" shall be understood to mean a hematoma inside the head and where the blood collects or accumulates outside the brain and its fibrous covering, the dura, but under the skull.

[0024] A "subdural hematoma" shall be understood to mean a hematoma inside the head and where the blood collects or accumulates between the brain and its dura.

[0025] An "intracerebral hematoma" or "intracerebral

hemorrhage" shall be understood to mean a hematoma inside the head and where the blood collects or accumulates in the brain tissue.

[0026] A "subarachnoid hematoma" or "subarachnoid hemorrhage" shall be understood to mean a hematoma inside the head and where the blood collects or accumulates around the surfaces of the brain, between the dura and arachnoid membranes.

[0027] An "extra cranial bleed" shall refer to any accumulation of blood outside the skull of the patient.

[0028] A "unilateral hematoma" shall be understood to mean a hematoma inside the head and in which blood collection or accumulation takes place on one side of the head.

[0029] A "bilateral hematoma" shall be understood to mean a hematoma inside the head and in which blood collection or accumulation takes place on both sides of the head.

[0030] The term "patient" and "subject" are used interchangeably, and shall be understood to include human beings, as well as other members of the animal kingdom.

[0031] The term "optical transceiver" is used to describe a fiber optic transmitter and receiver. It is also contemplated that, in the present disclosure, the term "optical transceiver" is also intended to refer to a device that acts solely as a light emitter (or light source) or a light detector.

[0032] Unless defined otherwise, all technical and scientific terms used herein have the same meaning as commonly understood by one of ordinary skill in the art to which this invention belongs.

[0033] As disclosed herein, there is provided a handheld optical imaging device for detection of intracranial hematoma, which employs near infrared (NIR) light detection. Identification of intracranial hematomas with NIR detection is made possible due to the fact that extravascular blood absorbs more NIR light than intravascular blood since there is a greater concentration of hemoglobin in the hematoma than in the brain tissue where blood is contained within vessels. Therefore, the absorbance of NIR light would be greater (and the reflected light less) in tissue containing a hematoma than in uninjured tissue.

[0034] The handheld optical imaging device therefore comprises a plurality of optical transceivers. In one embodiment, the plurality of optical transceivers comprises one or more NIR light sources and two or more NIR light detectors.

[0035] In order to facilitate its use in the field, for example, in an ambulance, on the sidelines of a sporting event or on a military field of battle, the device has a body of a suitable size and shape for operation by hand and for convenient portability. Further the device must be robust in design so it is suitable for use in rugged or remote environments.

[0036] Furthermore, since the imaging device is typically used to image the head of a patient, the device should be presented for use in a clean state. Accordingly, the device is provided with a removable cap that encompasses all parts which may come into contact with the

surface of the object being imaged in order to ensure cleanliness. The removable cap also must not compromise the light seal. It must be designed to be secure, while also being easily installed and removed.

[0037] Therefore, in accordance with the present invention, the handheld optical imaging device comprises a removable cap adapted for attachment to the body of the handheld device. The removable cap comprises a bellow support plate and a bellow mounted on the support plate. In one embodiment, the bellow support plate of the removable cap is mounted directly onto the body of the device on a suitably configured mounting surface. In one embodiment, the bellow support plate of the removable cap is attached to the body via a fixed base plate attached to the body of the device.

[0038] The device, in use, is passed over the surface of the object being imaged, e.g., a subject's skull, while the surface is irradiated with NIR. It is appreciated that a skull does not have a smooth surface, nor is a skull completely circular. Accordingly, in accordance with the present invention, the removable cap must be suitable for use on an uneven surface.

[0039] The removable cap must be able to deliver the NIR light to and detect the NIR light from desired locations. The removable cap must also be able to exclude external (ambient) light to ensure no tissue interactions with ambient light are measured alongside tissue interactions with intentionally delivered light, thereby improving the signal-to-noise ratio and reducing the incidence of false positive or negative readings. Accordingly, the removable cap is designed to prevent light leakage through sealing engagement between respective elements of the device, e.g., through fitting engagement between the removable cap and the mounting surface of the device, or where a base plate is employed, through fitting engagement between the fixed base plate and the removable cap. Fitting engagement between adjacent surfaces can be provided by the mating of raised profiles located around the circumference of an opening on one surface with corresponding recess on the adjacent surface. Light infiltration may also be prevented by the presence of an outer wall extending from the periphery of the mounting surface of the device to cover the interface between the mounting surface and the bellow support plate when the removable cap is installed.

[0040] Light leakage can also be minimized through the use of materials that do not internally reflect light, e.g., materials with a matte finish, or polymeric materials doped with NIR absorbants. In one embodiment, the support plate (and, when present, the base plate) is manufactured from a polymeric material. In a preferred embodiment, the polymeric material is ABS plastic. In one embodiment, the support plate and (if present) the base plate are each manufactured as a single piece.

[0041] The removable cap is also designed to prevent leakage between the cap and the surface of the object being imaged through the presence of a flexible bellow. The bellow provides an interface for the imaging device

with the surface of the object to be imaged, which is typically the head of a patient. Accordingly, the bellow is preferably manufactured from a biocompatible material. In one embodiment, the bellow is manufactured from medical grade silicone. In one embodiment, the bellow is provided with a matte black finish.

[0042] Also, since the imaging device is used to image objects having an uneven surface (e.g., a skull), the bellow should be manufactured from a material having enough flexibility to conform to a continuously varying C^n (where $n > 0$) surface. Selection of a suitable durometer rating for the bellow ensures formation of a shielded environment. The bellow may be provided in any suitable shape as may be required for the application, including but not limited to circular or triangular. In one embodiment, the bellow has a triangular shape that reflects the shape of the active imaging area, in accordance with a preferred configuration, as will be discussed in more detail below. In this embodiment, the triangular profile of the bellow acts as a directional guide to the user to facilitate the imaging process. In a further embodiment, the bellow is provided with markings to provide additional information regarding the imaging elements, for example, by indicating the location of the outer periphery of the active area, or the location of one or more optical transceivers. These guide markings may be in the form of a raised rib, a groove, or a colored line or other marking located on the outer surface of the bellow.

[0043] In one embodiment, the bellow is attached to a bellow support plate, wherein the bellow support plate is configured to interface with the surface of the object to be imaged. In this regard, the support plate is provided with a plurality of light pipes, each of which corresponds to a respective optical transceiver located within the body of the imaging device. Each light pipe is located in a respective housing. In a preferred embodiment, the support plate is provided with three fixed housings and at least one deformable housing extending toward the surface being imaged. In addition, each of the fixed and deformable housings has a tip which will contact the surface of the object to be imaged during use.

[0044] In one embodiment, the light pipes are formed of an optically clear material. In one embodiment, the optically clear material is an optically clear acrylic. In one embodiment, the light pipes have matted interiors to ensure they do not cause internal light reflection. In a preferred embodiment, the light pipes are provided with rounded tips to ensure good contact with the surface of the object to be imaged, which is typically soft tissue.

[0045] In a further preferred embodiment, solid clear cores are employed to prevent capillary action bringing fluids or contaminants into the unit, thereby avoiding blockage of the pipes or damage to the sensors.

[0046] In one embodiment, three of the optical transceivers of the imaging device are arranged in a triangular configuration. In a preferred embodiment, the triangle is an equilateral triangle. In a further embodiment, the three optical transceivers comprise one NIR light source and

two NIR light detectors. The equilateral triangular configuration ensures the adequate separation of the light detectors from the light source while maintaining the ability for all three fixed housings to simultaneously contact a continuously varying C^n (where $n > 0$) surface. The equilateral triangle arrangement also provides the most stable three point base when the device is placed on the object surface.

[0047] Further points of contact are provided by deformable housings located within the equilateral triangle formed by the fixed housings. In a preferred embodiment, two deformable housings are located at the edges of the triangle, thereby maintaining an optimal stability base. This also maintains the different detector separations in a linear arrangement, thereby allowing for improved optical sensitivity and accuracy of the device to detect inclusions.

[0048] The deformable housings are spring loaded and are designed to avoid any horizontal movement which might affect the data. The springs are hidden from the light path by the overlapping construction geometry to avoid light leakage. The springs are also situated between the detector and the light pipes to protect the detectors from any potential biological contamination (blood/hair). In one embodiment, the springs are held in place by a circular cap. In one embodiment, the springs are retained in place by spring plate. In one embodiment, the displacement of the light pipes within the housings is limited by stays.

[0049] The tips of the fixed and deformable housings of the bellow support plate sit above the lower perimeter rim of the bellow when not in use. It is therefore a requirement that the bellow be compressed to ensure the tips of the housings, and therefore the pipes housed therein, come into contact with the surface of the object to be imaged.

[0050] In addition, the removable cap should be designed to avoid formation of a "vacuum" seal, or suction effect, when in use, thereby ensuring that the device is able to move without hindrance across the surface to be imaged, while also avoiding light leakage. Accordingly, in one embodiment, the removable cap is provided with an air inflow system for allowing passage of air into the interior of the bellow when in use, without allowing infiltration of ambient light into the interior of the bellow.

[0051] In one embodiment of the air inflow system, the upper perimeter rim of the bellow is provided with grooves, or gaps, that allow air into the interior of the removable cap when installed on the body of the device while also preventing a direct line of sight between the exterior and interior. In one embodiment, air is allowed to pass through a small gap at the interface between the cap and body, without allowing light infiltration. In such an embodiment, one or more air holes are provided in the support plate to allow air into the interior of the bellow.

[0052] In one embodiment of the air inflow system, the lower perimeter rim of the bellow is provided with "S" shape grooves that ensure no direct line of sight between

the exterior of the bellow and the interior. The gaps in the upper perimeter rim or the "S" shaped grooves the lower perimeter rim therefore act to trap the light while allowing an air passage to form, thereby preventing the flexible bellow from "sealing" to the surface of the object being imaged, allowing free travel of the device across the surface during use. The bellow material may also be provided with a matte finish to minimize light reflection.

[0053] The handheld optical imaging device comprises a body shaped and sized to fit within the hand of the user.

[0054] In accordance with the present invention, the presence or absence of hematoma or bleeding event is determined using the device by pressing the deformable bellow of the removable cap against the surface of the head of a patient to bring the tips of the fixed and deformable housings into contact with the surface of the head. While the tips are in contact with the surface of the head, the device is passed over the surface while irradiating the surface with NIR light. Presence or absence of a hematoma or bleeding event is signaled by illumination of a light located on the body of the device.

[0055] Accordingly, the optical imaging device also comprises a processor configured to process data collected by the NIR detectors, the processor having a display for indicating the presence of hematoma. The presence of the hematoma is based upon a measured characteristic of the infrared light passing through the tissue, for example, an optical density associated with a region of the brain. In one embodiment, the device comprises status indicator lights, which are provided to indicate the current status of the imaging process. For example, the status indicators may use different colours and/or blinking patterns to indicate, for example, that the device is in scanning mode, that an imaging error has occurred, or that a hematoma has been detected.

[0056] In one embodiment, the body is provided as a two-part housing, and contained within the body are the electronic components required for function. In one embodiment, the body is manufactured from a polymeric material. In one embodiment, the polymeric material is ABS plastic. In one embodiment, the polymeric material is flame retardant. The body may be manufactured using any suitable method known in the art, including, but not limited to, injection molding or extrusion processes or 3D printing processes.

[0057] The imaging process is activated using a power switch located on the body of the device. In one embodiment, the power switch is provided as a "deadman's switch", where the imaging process is activated only when the button is depressed. In one embodiment, the device is provided with two switches, one on each side of the body to allow use by both left handed and right handed users. In a preferred embodiment, the device is powered by a battery for ease of portability and use in remote areas where access to a power supply may not readily be available.

[0058] In accordance with one embodiment of the present invention, as depicted in FIGS 1-6, the device

comprises a removable cap **20** attached directly to body **12** of device **10** via mounting surface **22** of the body. In this embodiment, mounting surface **22** has a generally planar mounting face **23** and outer wall **25** extending from the periphery of the face **23** which together define mounting surface inner volume **24** in which removable cap **20** is mounted.

[0059] The mounting face comprises a plurality of openings adapted to receive optical transceivers located within the body of device **10**. Removable cap **20** comprising bellow support plate **40** and deformable bellow **60** sealingly engaged to the support plate. Bellow support plate **40** comprises first support plate face **5** shaped to engage the mounting face **23** when removable cap **20** is mounted within the mounting surface inner volume **24**, and second support plate face **6** configured to face a surface of the object to be imaged.

[0060] Details of the removable cap in accordance with this embodiment are depicted in FIGS 3 to 6.

[0061] In this embodiment, bellow support plate **40** further comprises two fixed housings **43B** and one fixed housing **43A**, each of the fixed housings **43A** and **43B** being adapted to receive a respective fixed light pipe **35A** or **35B**. The three fixed housings **43A** and **43B** are arranged in an equilateral triangular configuration.

[0062] In this embodiment, further points of contact are provided by two deformable housings **44**, each of which are adapted to receive a movable light pipe **45**. In this embodiment, two deformable housings **44** are located at the edges of the triangle, thereby maintaining an optimal stability base.

[0063] In this embodiment, each of the light pipes corresponds to a respective optical transceiver located in the body of the device. Accordingly, bellow support plate **40** further comprises elements **53A** and **53B** on first support plate face **5**, which are each adapted to fittingly receive a respective optical transceiver. In this embodiment, the optical transceiver corresponding to fixed light pipe **35A** is a NIR light source, and the optical transceivers corresponding to fixed light pipes **35B** are NIR light detectors.

[0064] In this embodiment, each of the fixed and deformable housings **43AB**, **44** extends from second support plate face **6** towards the surface of the object being imaged. The tips of each of the fixed and deformable housings are adapted to contact the surface of the object to be imaged.

[0065] In this embodiment, and as shown in FIGS 5 and 6, deformable housings **44** are spring loaded and are designed to avoid any horizontal movement which might affect the data. Springs **47** are hidden from the light path by the overlapping construction geometry to avoid light leakage. The springs are also situated between the detector and the light pipes to protect the detectors from any potential biological contamination (blood/hair). Springs **47** are retained in place by cap **49**, and the displacement of light pipes **45** within the housings is limited by a stay **48**. Each of caps **49** is adapted to engage a

respective optical transceiver.

[0066] In this embodiment, light infiltration is prevented by fitting engagement between the bellow support plate **40** and outer wall **25** extending from the periphery of the mounting surface **22**. The outer wall **25** is provided to cover the interface between the bellow support plate **40** and mounting face **23** when removable cap **20** is installed.

[0067] In this embodiment, deformable bellow **60** has a generally C-shaped cross-sectional profile defining first, upper perimeter rim **61** and second, lower perimeter rim **62**. In this embodiment, first perimeter rim **61** sealingly engages bellow support plate **40**, and fits within outer wall **25** of mounting surface **22** when cap **20** is mounted within the mounting surface inner volume **24**. In this embodiment, cap **20** is held secure to the mounting surface by resilient and frictional fit of upper perimeter rim **61** within outer walls **25**, without necessitating the use of additional attachment means.

[0068] The tips of the fixed and deformable housings **43**, **44** of bellow support plate **40** sit above second perimeter rim **62** of bellow **60** when not in use. It is therefore a requirement that bellow **60** be compressed to ensure the tips of the housings, and therefore the fibers housed therein, come into contact with the surface of the object to be imaged. Accordingly, in use, the lower perimeter rim **62** of bellow **60** contacts the surface of the object to be imaged and the bellow is deformed to allow the tips of the fixed and deformable housings to contact the surface of the object to be imaged.

[0069] As shown in FIGS 3 and 4, bellow **60** is provided with markers **69A** located to indicate the outer limits of the active imaging area within the bellow, and marker **69B** located to indicate the location of the irradiating optical transceiver, all of which provide guidance to the user to ensure complete coverage of the surface being imaged, thereby facilitating the imaging process.

[0070] In this embodiment, the removable cap and bellow are provided in a triangular shape to correspond to the triangular configuration of the optical transceivers.

[0071] In this embodiment, upper perimeter rim **61** of bellow **60** is provided with a series of grooves **38** that allow air into the interior of the removable cap when installed on the body of the device through gap **18** at the interface between cap **20** and body **12**, without allowing light infiltration. In this embodiment, the air inflow system further comprises openings **68** on the bellow support plate corresponding to the grooves in the first perimeter rim of the bellow. In this embodiment, air holes **46** are also provided in support plate **40** to allow air into the interior of the bellow, thereby preventing suction events when bellow **60** is pressed to the surface of the object being imaged.

[0072] In this embodiment, device **10** includes status indicator light **13**, which are provided to indicate the current status of the imaging process. For example, status indicator light **13** uses a different colour to indicate that the device is in scanning mode (e.g., green), that an im-

aging error has occurred (e.g., orange), or that a hematoma has been detected (e.g., red).

[0073] In this embodiment, device **10** includes two power buttons **14**, one on each side of the body to allow use by both left handed and right handed users, each button provided as a "deadman's switch", where the imaging process is activated only when the button is depressed.

[0074] In accordance with a further embodiment of the present invention, as depicted in FIGS 7 to 17, the device comprises a fixed base plate **300** configured to receive the removable cap **200**. As depicted in FIGS 9 and 10, the fixed base plate **300** has a generally planar body **320** comprising a base plate face **305** and a plurality of base plate openings **310A-C** in the planar body arranged in a predetermined configuration. The base plate openings **310A-C** are adapted to receive respective optical transceivers. The fixed base plate **300** also comprises an outer wall **315** extending from the periphery of the base plate face **305**. The outer wall **315** and the base plate face **305** together define a base plate inner volume.

[0075] In this embodiment, light infiltration is prevented by fitting engagement between the fixed base plate **300** and the bellow support plate **400** provided by the mating of raised profiles **330A-C** located around the circumference of each the openings **310A-C** for the optical transceivers on the fixed base plate **300** with corresponding recesses **415A-C** on the bellow support plate **400**, which is described in further detail below.

[0076] In this embodiment, light infiltration is also prevented by the presence of the outer wall **315** extending from the periphery of the fixed base plate **300**. The outer wall **315** is provided to cover the interface between the fixed base plate **300** and the bellow support plate **400** when the removable cap is installed.

[0077] In the embodiment depicted in FIGS. 12A and 12B, the removable optical imaging device cap **200** comprises bellow support plate **400** and deformable bellow **600**.

[0078] In this embodiment, bellow support plate **400** comprises first portion **410** and second portion **420**. The first portion **410** of bellow support plate **400** is shaped to fit within the base plate inner volume, such that first support plate face **405** fittingly engages fixed base plate face **305** when the first portion **410** is located within the base plate inner volume. The bellow support plate **400** also has a second support plate face **406** configured to face a surface of the body to be imaged, and three fixed housings **430A,B** and two deformable housings **440** extending from the second support plate face **406** toward the surface being imaged. Each of fixed housings **430A,B** is adapted to receive therein a fixed light pipe **435**, each of which corresponds to one of the first optical transceivers. Each of the deformable housings **440** is adapted to receive a light pipe **445**, each of which corresponds to a second optical transceiver. In addition, each of the fixed and deformable housings have a tip **432A,B**, **442** adapted to contact the surface of the object to be imaged.

[0079] The second portion of bellow support plate **400** is adapted to sealingly engage deformable bellow **600** to eliminate infiltration of ambient light to the detectors.

[0080] As discussed above, bellow support plate **400** comprises recesses/dimples **415A-C** suitably sized and located to receive raised profiles **330A-C** surrounding openings **310A-C** for the optical transceivers on fixed base plate **300**. FIG 11 illustrates one embodiment of recessed openings **415A-C** on bellow support plate **400**. The mating of recessed openings **415A-C** with respective raised profiles **330A-C** is designed to prevent light leakage between light source and detectors at the connection plane for removable cap **200**.

[0081] Accordingly, each of the three fixed housings **430A,B** on bellow support plate **400** is provided to correspond to one of the three optical transceivers **110**. Each fixed housing **430A,B** contains a light pipe **435** formed of an optically clear material.

[0082] In this embodiment, further points of contact are provided by deformable housings **440**. In this embodiment, two deformable housings **440** are located at the edges of the triangle, thereby maintaining an optimal stability base. These deformable housings **440** each contain a light pipe **435**.

[0083] The deformable housings are spring loaded and are designed to avoid any horizontal movement which might affect the data. Springs **447** are hidden from the light path by the overlapping construction geometry to avoid light leakage. The springs are also situated between the detector and the light pipes to protect the detectors from any potential biological contamination (blood/hair). Springs **447** are retained in place by spring plate **448**.

[0084] FIG 16 illustrates an exploded view of a removable cap **200** in accordance with this embodiment, and includes a depiction of the components of deformable housings **440**.

[0085] In accordance with this embodiment of the present invention, as depicted in FIGs 15, removable optical imaging device cap **200** comprises deformable bellow **600** sealingly engaged to bellow support plate **400**.

[0086] In this embodiment, deformable bellow **600** has a generally C-shaped cross-sectional profile defining a first, upper perimeter rim **610** and a second, lower perimeter rim **620**. The C-shaped profile is clearly depicted in FIG 15. Bellow **600** is adapted at the first perimeter rim to sealingly engage the second portion of the bellow support plate by sealing fit with a flange located on the support plate.

[0087] Tips **432A,B**, **442** of housings **430A,B**, **440** of bellow support plate **400** sit above second perimeter rim **620** of bellow **600** when not in use. It is therefore a requirement that bellow **600** be compressed to ensure the tips of the housings, and therefore the fibers housed therein, come into contact with the surface of the object to be imaged.

[0088] As depicted in FIG 12B, bellow **600** is provided with "S" shaped grooves **630** along the rim to ensure a

light seal while preventing a suction effect when the rim of the bellow is in contact with the surface being imaged. In this embodiment, the "S" shaped grooves and the matte finish combine to trap the light while allowing an air passage to form, thereby preventing the molded silicone bellow from "sealing" to the surface of the object being imaged, allowing free travel of the device across the surface during use.

[0089] In accordance with the embodiment depicted in FIG 16, there is provided an attachment means for reversibly attaching bellow support plate **400** to fixed base plate **300**.

[0090] In this embodiment, the attachment means is provided by a tab and slot mechanism, wherein tab **510** is located on bellow support plate **400** and slot **520** is located on outer wall **315** of base plate **300**. To form a seal, tab **510** is inserted into slot **520**, and fixed base plate **300** then "hinges" into place and a seal is formed between fixed base plate **300** and bellow support plate **400**. In this embodiment, the attachment means further comprises one or more "soft buttons" **530** located on the outer edge of the bellow that are positioned to "click" into recesses **340** located on the inner surface of outer wall **315**.

[0091] The attachment means is configured such that when tab **510** is engaged in slot **520**, recesses **415A-C** and respective raised profiles **330A-C** are aligned. This configuration also provides an optimum fit of the transceivers into the recesses/dimples on bellow support plate **400**.

[0092] In one embodiment, the attachment means is provided by a bayonet style fitting, although any means that provides an easy "in/out" connection is suitable and considered to be within the scope of the present invention.

[0093] The invention will now be described with reference to specific examples. It will be understood that the following examples are intended to describe embodiments of the invention and are not intended to limit the invention in any way.

EXAMPLES

EXAMPLE 1: Handheld Optical Imaging Device

[0094] FIGS. 1A and B and 2A and B depict one embodiment of a handheld optical imaging device **10** in accordance with the present invention. The optical imaging device **10** comprises a removable cap **20** attached to body **12** suitably sized and shaped to easily fit within the hand of a user.

[0095] In the embodiment depicted in FIGS 1A and B and 2A and B the device comprises one NIR light source **180**, and four NIR light detectors **170**.

[0096] An exploded view of this embodiment of the optical imaging device is provided in FIG 2B. FIG 2B depicts two part housing **120A,B** that forms the body. Housing **120A,B** is designed to contain within it the electronics

160 required for function, as well as the processor required to analyze the data obtained during the imaging process.

5 EXAMPLE 2: Handheld Optical Imaging Device

[0097] FIGS. 7A-C and 8 depict another embodiment of a handheld optical imaging device **100** in accordance with the present invention. The optical imaging device **100** comprises a removable cap **200** attached to a body suitably sized and shaped to easily fit within the hand of a user.

[0098] In the embodiment depicted in FIGS 7A-C and 8, the device comprises one NIR light source **880**, and four NIR light detectors **870**.

[0099] An exploded view of this embodiment of the optical imaging device is provided in FIG 8. FIG 8 depicts two part housing **820A,B** that forms the body. Housing **820A,B** is designed to contain within it the electronics **860** required for function, as well as the processor required to analyze the data obtained during the imaging process.

[0100] Prior to use, removable cap **200** is installed via attachment to fixed base plate **300**. The device is powered by a battery (not shown).

EXAMPLE 3: Hybrid Military Flashlight/Optical Imaging Device

[0101] FIGS 18 to 20 depict an alternative embodiment of a handheld optical imaging device **700** in accordance with the present invention. This embodiment is based on a modification of a standard issue military flashlight. In this embodiment, the optical imaging device **700** comprises a removable cap **725** attached to the main body **720** of a military flashlight, wherein the head **710** of the flashlight is provided with a cap port **730** for receiving the removable cap **725**, in addition to the standard flashlight function. When not in use as an optical imaging device, the removable cap **725** is removed and the cap port **730** is covered by a port cover **735**, as depicted in FIG 19. Prior to use as an imaging device, the removable cap **725** is installed via attachment to the cap port **730**.

[0102] FIG 18 depicts the military embodiment with the removable cap **725** installed in the cap port **730**.

[0103] In the embodiment depicted in FIG 20, the device comprises one NIR light source **780**, and four NIR light detectors **770**.

[0104] An exploded view of this embodiment of the optical imaging device is provided in FIG 20. FIG 20 depicts the elongated housing that forms the main body **720** of the device **700**. The housing is designed to contain within it the electronics **760** required for function, as well as the processor required to analyze the data obtained during the imaging process. A flashlight power switch **790** is provided to activate the flashlight function, and an imaging device power switch (not shown) is provided to activate the imaging function. The device is powered by battery

750.

Claims

1. A near infrared (NIR) light optical imaging device (10, 100) for imaging an object, the imaging device comprising:

a body (12, 120, 720, 820),
 three first optical transceivers (170, 870) and at least one second optical transceiver (180, 880) located within the body (12, 120, 720, 820),
 a mounting surface (22) located on the body (12, 120), the mounting surface (22) having a generally planar mounting face (23) and an outer wall (25) extending from the periphery of the face (23), wherein the outer wall (25) and the face (23) define a mounting surface inner volume (24), the mounting face (23) comprising a plurality of openings arranged in a predetermined configuration and adapted to receive the first and second optical transceivers (170, 870, 180, 880), and
 an optical imaging device cap (20, 200) removably mounted on the mounting surface (22), wherein the optical imaging device cap (20, 200) comprises a bellow support plate (40, 400) and a deformable bellow (60, 600) sealingly engaged to the bellow support plate (40, 400), the bellow support plate (40, 400) comprising:

a first support plate face (5, 405) shaped to engage the mounting face (23) when the device cap (20, 200) is mounted within the mounting surface inner volume (24),

a second support plate face (6, 406) configured to face a surface of the object to be imaged,

three fixed housings (43AB, 430AB), each of the fixed housings (43AB, 430AB) being adapted to receive a fixed light pipe (35AB, 435), each of the fixed light pipes (35AB, 435) corresponding to one of the first optical transceivers (170, 870), and

at least one deformable housing (44, 440) adapted to receive a movable light pipe (45, 445), the deformable housing (44, 440) corresponding to the at least one second optical transceiver (180, 880), each of the fixed (43AB, 430AB) and deformable housings (44, 440) having a tip (432, 442) adapted to contact the surface of the object to be imaged; and

the deformable bellow (60, 600) having a generally C-shaped cross-sectional-profile defining a first perimeter rim (61, 610) and a second pe-

rimeter rim (62, 620), wherein the first perimeter rim (61, 610) sealingly engages the bellow support plate (40, 400), and

wherein, in use, the second perimeter rim (62, 620) of the bellow (60, 600) contacts the surface of the object to be imaged and the bellow (60, 600) is deformed to allow the tips of the fixed (43AB, 430AB) and deformable housings (44, 440) to contact the surface of the object to be imaged.

2. The device according to claim 1, wherein the first perimeter rim (61, 610) fits within the outer wall (25) of the mounting surface when the device cap (20, 200) is mounted within the mounting surface inner volume (24).
3. The device according to claim 1 or 2, further comprising air inflow system for allowing passage of air from the exterior of the device into the interior of the bellow (60) when in use, wherein preferably the air inflow system comprises one or more air flow holes (46) between the first and second support plate faces (5, 6).
4. The device according to claim 3, wherein the air inflow system further comprises one or more grooves (38) in the first perimeter rim (61) of the bellow (60), wherein preferably the air inflow system further comprises one or more openings (68) on the bellow support plate (40) corresponding to the one or more grooves in the first perimeter rim of the bellow (60).
5. The device according to claim 1, wherein the mounting surface is formed as a fixed base plate (300) attached to the body of the device, and the first support plate face (405) is shaped to fittingly engage the base plate face (305), wherein preferably the fixed base plate (300) face further comprises a raised profile (330) around the circumference of each of the base plate openings (310), and the first support plate face (405) comprises recesses (415) to receive the raised profiles (330), thereby providing the fitting engagement of the first support plate face (405) and the fixed base plate face (305).
6. The device according to claim 5, wherein the device cap further comprises attachment means for reversibly attaching the bellow support plate (400) to the fixed base plate (300), wherein preferably the attachment means comprise a tab (510) and slot mechanism (520), wherein the tab (510) is located on the bellow support plate (400) and the slot (520) is located on the outer wall (315) of the base plate (300).
7. The device according to any one of claims 1 to 6, wherein the bellow (600) further comprises nonlinear, radially disposed grooves (630) at the second

perimeter rim (620), wherein preferably the radially disposed grooves are s-shaped.

8. The device according to any one of claims 1 to 7, wherein the at least one deformable housing (44, 440) is two deformable housings. 5
9. The device according to any one of claims 1 to 8, wherein the fixed housings (43, 430) form a triangle, wherein preferably the triangle is an equilateral triangle. 10
10. The device according to claim 9, wherein the at least one deformable housing (44, 440) is located at the edges of the triangle formed by the fixed housings (43, 430). 15
11. The device according to any one of claims 1 to 10, wherein the bellow support plate (40, 400) is formed from a polymeric material, wherein preferably the polymeric material is ABS plastic, optionally doped with a near-infrared absorbant. 20
12. The device according to any one of claims 1 to 11, wherein the bellow (60, 600) is formed from silicone polymer. 25

Patentansprüche

1. Eine Nahinfrarot (NIR)-Licht optische Bildgebungs-
vorrichtung (10, 100) zur Darstellung eines Objekts,
wobei die Bildgebungs Vorrichtung umfasst: 30
 - ein Gehäuse (12, 120, 720, 820), 35
 - drei erste optische Transceiver (170, 870) und
wenigstens einen zweiten optischen Transcei-
ver (180, 880), die innerhalb des Gehäuses (12,
120, 720, 820) vorliegen,
 - eine an dem Gehäuse (12, 120) befindliche Befestigungsfläche (22), wobei die Befestigungsfläche (22) eine im Wesentlichen ebene Befestigungs-
oberseite (23) und eine von dem Außenrand der Oberseite (23) hervortretende äußere Wand (25) aufweist, wobei die äußere Wand (25) und die Oberseite (23) einen Innenbereich (24) der Befestigungsfläche definieren, die Befestigungs-
oberseite (23) eine in einer vorgegebenen Konfiguration angeordnete und zur Aufnahme der ersten und zweiten optischen
Transceiver (170, 870, 180, 880) angepasste
Mehrzahl von Öffnungen umfasst, und
eine Kappe für die optische Bildgebungs-
vorrichtung (20, 200), die entferntbar an der Befestigungsfläche (22) befestigt ist, 40
 - wobei die Kappe (20, 200) für die optische Bildgebungs-
vorrichtung eine Balgträgerplatte (40, 400) und einen abdichtend mit der Balgträger-
platte (40, 400) ineinandergreifenden verformbaren Balg (60, 600) umfasst, 45
 - wobei die Balgträgerplatte (40, 400) umfasst: 50
 - eine erste Trägerplattenfläche (5, 405), die
so ausgeformt ist, dass sie in die Befestigungs-
oberseite (23) eingreift, wenn die
Kappe (20, 200) der Vorrichtung in dem Innenbereich (24) der Befestigungs-
oberseite befestigt ist,
 - eine zweite Trägerplattenfläche (6, 406),
die so ausgestaltet ist, dass sie einer Ober-
fläche des abzubildenden Objekts zuge-
wandt ist,
 - drei feststehende Gehäuse (43AB, 430AB),
wobei jedes der feststehenden Gehäuse
(43AB, 430AB) so angepasst ist, dass es
einen befestigten Lichtleiter (35AB, 435)
aufnimmt, wobei jeder der befestigten Licht-
leiter (35AB, 435) einem der ersten opti-
schen Transceiver (170, 870) zugehörig ist,
und
wenigstens ein verformbares Gehäuse (44,
440), das angepasst ist, dass es einen be-
weglichen Lichtleiter (45, 445) aufnimmt,
wobei das verformbare Gehäuse (44, 440)
dem wenigstens einen zweiten optischen
Transceiver (180, 880) zugehörig ist, wobei
jedes der feststehenden (43AB, 430AB)
und verformbaren Gehäuse (44, 440) eine
zur Berührung der Oberfläche des abzubil-
denden Objekts angepasste Spitze (432,
442) aufweist; und 55

platte (40, 400) ineinandergreifenden verformbaren Balg (60, 600) umfasst, wobei die Balgträgerplatte (40, 400) umfasst:

2. Die Vorrichtung gemäß Anspruch 1, wobei der erste Umfassungsrand (61, 610) in die äußere Wand (25) der Befestigungsfläche passt, wenn die Kappe (20, 200) der Vorrichtung in dem Innenbereich (24) der Befestigungsfläche befestigt ist.
3. Die Vorrichtung gemäß Anspruch 1 oder 2, ferner umfassend ein Lufteinlasssystem, um während der

- Benutzung den Durchlass von Luft von außerhalb der Vorrichtung in den Innenraum des Balgs (60) zu ermöglichen, wobei das Lufteinlasssystem bevorzugt ein oder mehrere Luftflusslöcher (46) zwischen den ersten und zweiten Trägerplattenflächen (5, 6) umfasst.
4. Die Vorrichtung gemäß Anspruch 3, wobei das Lufteinlasssystem außerdem eine oder mehrere Rillen (38) in dem ersten Umfassungsrand (61) des Balgs (60) umfasst, wobei bevorzugt das Lufteinlasssystem außerdem eine oder mehrere Öffnungen (68) an der Balgrägerplatte (40), die der einen oder den mehreren Rillen in dem ersten Umfassungsrand des Balgs (60) entsprechen, umfasst.
5. Die Vorrichtung gemäß Anspruch 1, wobei die Befestigungsfläche als eine an das Gehäuse der Vorrichtung angebrachte feststehende Basisplatte (300) ausgeformt ist, und die erste Trägerplattenfläche (405) so ausgeformt ist, dass sie passend mit der Basisplattenfläche (305) ineinandergreift, wobei bevorzugt die Fläche der feststehenden Basisplatte (300) außerdem ein erhabenes Profil (330) entlang des Umfangs jeder der Basisplattenöffnungen (310) umfasst, und die erste Trägerplattenfläche (405) Aussparungen (415) enthält, um die erhabenen Profile (330) aufzunehmen, um dadurch das passende Ineinandergreifen der ersten Trägerplattenfläche (405) und der feststehenden Basisplattenfläche (305) zu gewährleisten.
6. Die Vorrichtung gemäß Anspruch 5, wobei die Kappe der Vorrichtung außerdem Befestigungsmittel zur reversiblen Befestigung der Balgrägerplatte (400) an die feststehende Basisplatte (300) umfasst, wobei bevorzugt die Befestigungsmittel einen Laschen (510) und Schlitzmechanismus (520) umfassen, wobei die Lasche (510) sich an der Balgrägerplatte (400) befindet und der Schlitz (520) sich an der äußeren Wand (315) der Basisplatte (300) befindet.
7. Die Vorrichtung gemäß einem der Ansprüche 1 bis 6, wobei der Balg (600) zusätzlich nichtlineare, radial angeordnete Rillen (630) an dem zweiten Umfassungsrand (620) umfasst, wobei die radial angeordneten Rillen bevorzugt s-förmig sind.
8. Die Vorrichtung gemäß einem der Ansprüche 1 bis 7, wobei das wenigstens eine deformierbare Gehäuse (44, 440) zwei deformierbare Gehäuse darstellt.
9. Die Vorrichtung gemäß einem der Ansprüche 1 bis 8, wobei die feststehenden Gehäuse (43, 430) ein Dreieck bilden, wobei das Dreieck bevorzugt ein gleichseitiges Dreieck ist.
10. Die Vorrichtung gemäß Anspruch 9, wobei sich das

wenigstens eine verformbare Gehäuse (44, 440) an den Kanten des Dreiecks, dass durch die feststehenden Gehäuse (43, 430) gebildet wird, befindet.

- 5 11. Die Vorrichtung gemäß einem der Ansprüche 1 bis 10, wobei die Balgrägerplatte (40, 400) aus einem Polymermaterial gebildet ist, wobei das Polymermaterial bevorzugt ABS-Plastik ist, welches optional mit einem Nahinfrarot-Absorber dotiert ist.
- 10 12. Die Vorrichtung gemäß einem der Ansprüche 1 bis 11, wobei der Balg (60, 600) aus Silikonpolymer gebildet ist.

Revendications

1. Dispositif d'imagerie optique en lumière proche infrarouge (NIR) (10, 100) pour l'imagerie d'un objet, le dispositif d'imagerie comprenant :

un corps (12, 120, 720, 820),
trois premiers émetteurs-récepteurs optiques (170, 870) et au moins un deuxième émetteur-récepteur optique (180, 880) situés dans le corps (12, 120, 720, 820),
une surface de montage (22) située sur le corps (12, 120), la surface de montage (22) présentant une face de montage sensiblement plane (23) et une paroi extérieure (25) s'étendant à partir de la périphérie de la face (23), la paroi extérieure (25) et la face (23) délimitant un volume intérieur de surface de montage (24), la face de montage (23) comprenant une pluralité d'ouvertures agencées dans une configuration prédéterminée et conçues pour recevoir les premiers et deuxième(s) émetteurs-récepteurs optiques (170, 870, 180, 880), et
une coiffe de dispositif d'imagerie optique (20, 200) montée amovible sur la surface de montage (22),
dans lequel la coiffe de dispositif d'imagerie optique (20, 200) comprend une plaque de support de soufflet (40, 400) et un soufflet déformable (60, 600) mis en contact étanche avec la plaque de support de soufflet (40, 400),
la plaque de support de soufflet (40, 400) comprenant :

une première face de plaque de support (5, 405) façonnée pour venir en contact avec la face de montage (23) lorsque la coiffe de dispositif (20, 200) est montée dans le volume intérieur de surface de montage (24),
une deuxième face de plaque de support (6, 406) configurée pour faire face à une surface de l'objet soumis à l'imagerie,
trois logements fixes (43AB, 430AB), cha-

- cun des logements fixes (43AB, 430AB) étant conçu pour recevoir un conduit de lumière fixe (35AB, 435), chacun des conduits de lumière fixes (35AB, 435) correspondant à l'un des premiers émetteurs-récepteurs optiques (170, 870), et au moins un logement déformable (44, 440) conçu pour recevoir un conduit de lumière mobile (45, 445), le logement déformable (44, 440) correspondant à l'au moins un deuxième émetteur-récepteur optique (180, 880), chacun des logements fixes (43AB, 430AB) et déformable(s) (44, 440) ayant une extrémité (432, 442) conçue pour toucher la surface de l'objet soumis à l'imagerie ; et
- le soufflet déformable (60, 600) présentant un profil de section transversale sensiblement en C définissant un premier rebord périmétrique (61, 610) et un deuxième rebord périmétrique (62, 620), le premier rebord périmétrique (61, 610) venant en contact étanche avec la plaque de support de soufflet (40, 400), et dans lequel, lors de l'utilisation, le deuxième rebord périmétrique (62, 620) du soufflet (60, 600) touche la surface de l'objet soumis à l'imagerie et le soufflet (60, 600) se déforme pour permettre aux extrémités des logements fixes (43AB, 430AB) et déformable(s) (44, 440) de toucher la surface de l'objet soumis à l'imagerie.
2. Dispositif selon la revendication 1, dans lequel le premier rebord périmétrique (61, 610) s'ajuste à l'intérieur de la paroi extérieure (25) de la surface de montage lorsque la coiffe de dispositif (20, 200) est montée dans le volume intérieur de surface de montage (24).
 3. Dispositif selon la revendication 1 ou 2, comprenant en outre un système d'entrée d'air destiné à permettre le passage d'air de l'extérieur du dispositif à l'intérieur du soufflet (60) lors de l'utilisation, dans lequel de préférence le système d'entrée d'air comprend un ou plusieurs trous d'écoulement d'air (46) entre les première et deuxième faces de plaque de support (5, 6).
 4. Dispositif selon la revendication 3, dans lequel le système d'entrée d'air comprend en outre une ou plusieurs rainures (38) dans le premier rebord périmétrique (61) du soufflet (60), dans lequel de préférence le système d'entrée d'air comprend en outre une ou plusieurs ouvertures (68) sur la plaque de support de soufflet (40) correspondant à la ou aux rainures dans le premier rebord périmétrique du soufflet (60).
 5. Dispositif selon la revendication 1, dans lequel la surface de montage est formée sous la forme d'une plaque de base fixe (300) attachée au corps du dispositif, et la première face de plaque de support (405) est façonnée pour venir en contact ajusté avec la face de plaque de base (305), dans lequel de préférence la face de la plaque de base fixe (300) comprend en outre un profil surélevé (330) autour de la circonférence de chacune des ouvertures de plaque de base (310), et la première face de plaque de support (405) comprend des évidements (415) pour recevoir les profils surélevés (330), ce qui permet d'assurer le contact ajusté de la première face de plaque de support (405) et de la face de plaque de base fixe (305).
 6. Dispositif selon la revendication 5, dans lequel la coiffe de dispositif comprend en outre des moyens de fixation pour attacher de manière réversible la plaque de support de soufflet (400) à la plaque de base fixe (300), dans lequel de préférence les moyens de fixation comprennent un mécanisme à languette (510) et à fente (520), dans lequel la languette (510) est située sur la plaque de support de soufflet (400) et la fente (520) est située sur la paroi extérieure (315) de la plaque de base (300).
 7. Dispositif selon l'une quelconque des revendications 1 à 6, dans lequel le soufflet (600) comprend en outre des rainures non linéaires disposées radialement (630) au niveau du deuxième rebord périmétrique (620), dans lequel de préférence les rainures disposées radialement sont en S.
 8. Dispositif selon l'une quelconque des revendications 1 à 7, dans lequel l'au moins un logement déformable (44, 440) est deux logements déformables.
 9. Dispositif selon l'une quelconque des revendications 1 à 8, dans lequel les logements fixes (43, 430) forment un triangle, dans lequel de préférence le triangle est un triangle équilatéral.
 10. Dispositif selon la revendication 9, dans lequel l'au moins un logement déformable (44, 440) est situé au niveau des côtés du triangle formé par les logements fixes (43, 430).
 11. Dispositif selon l'une quelconque des revendications 1 à 10, dans lequel la plaque de support de soufflet (40, 400) est formée à partir d'un matériau polymère, dans lequel de préférence le matériau polymère est un plastique ABS, facultativement dopé avec un absorbant dans le proche infrarouge.
 12. Dispositif selon l'une quelconque des revendications 1 à 11, dans lequel le soufflet (60, 600) est formé à partir de polymère de silicone.

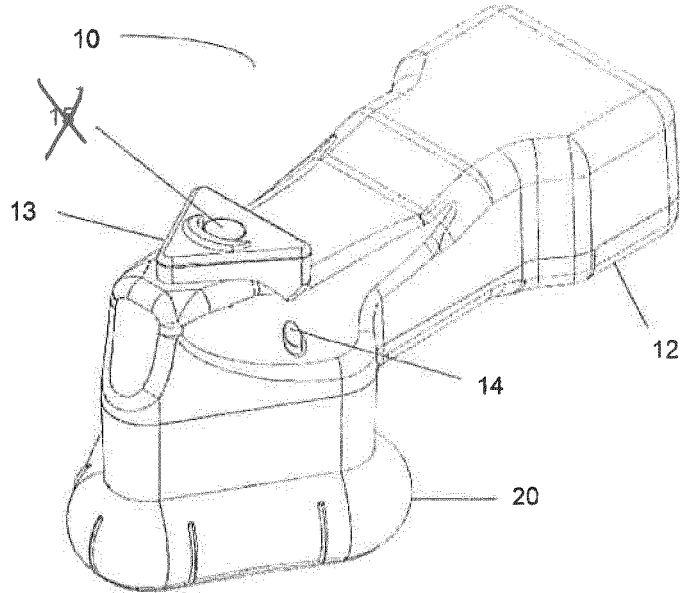

FIG 1A

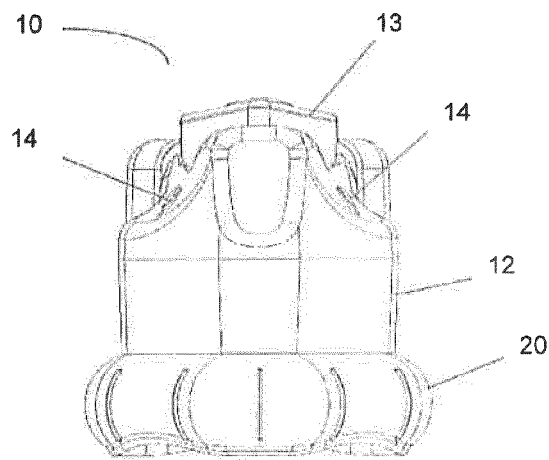
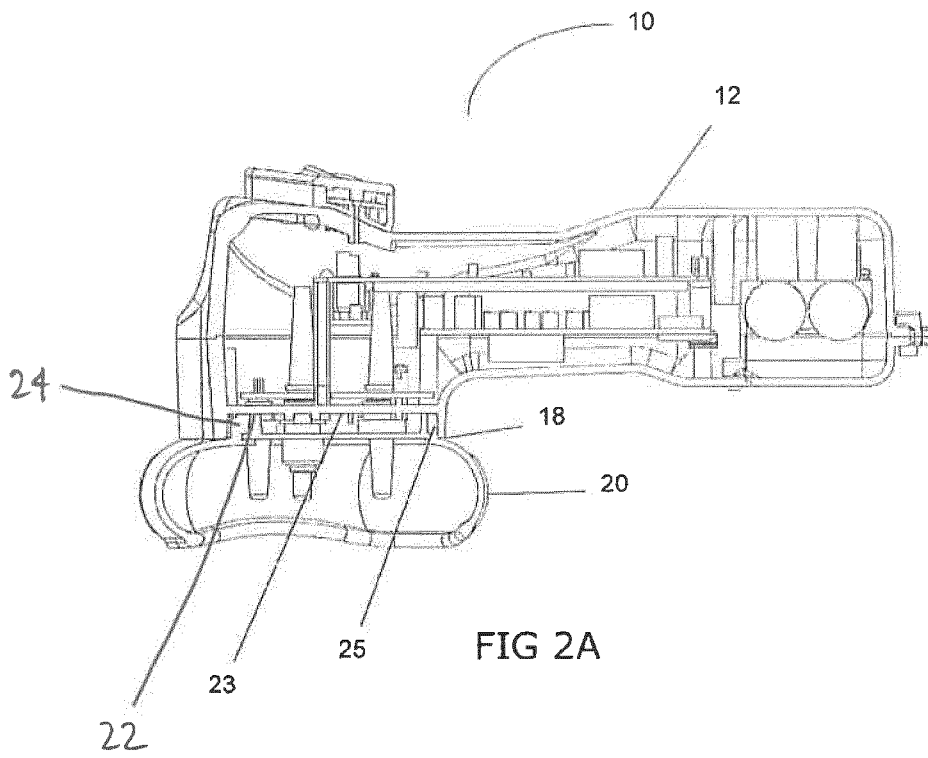

FIG 1B



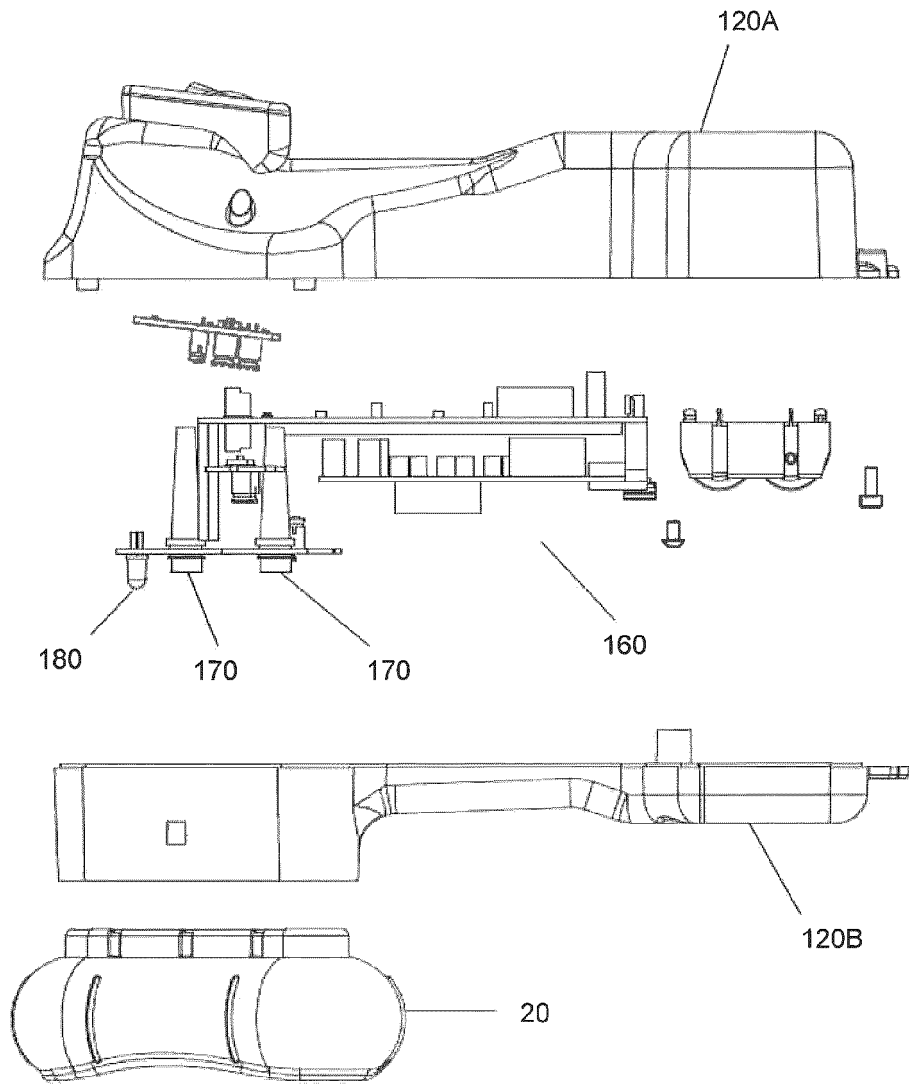

FIG 2B

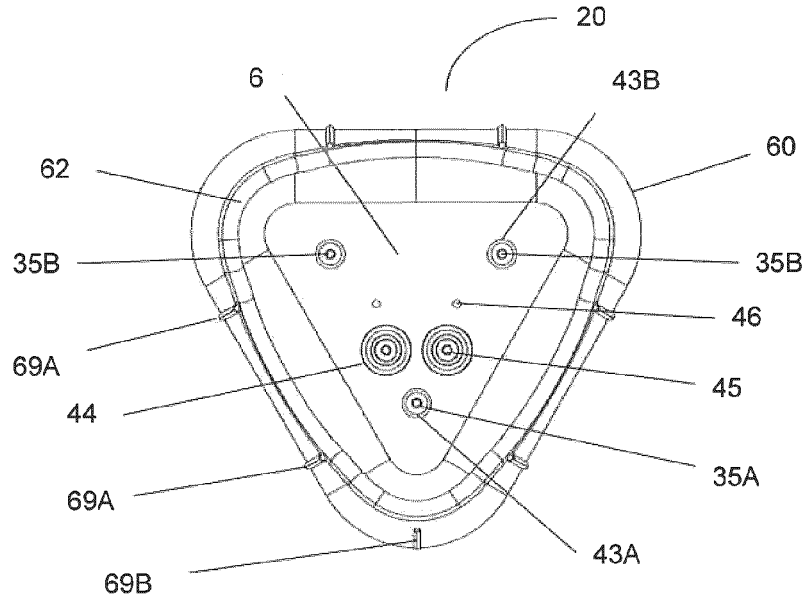

FIG 3

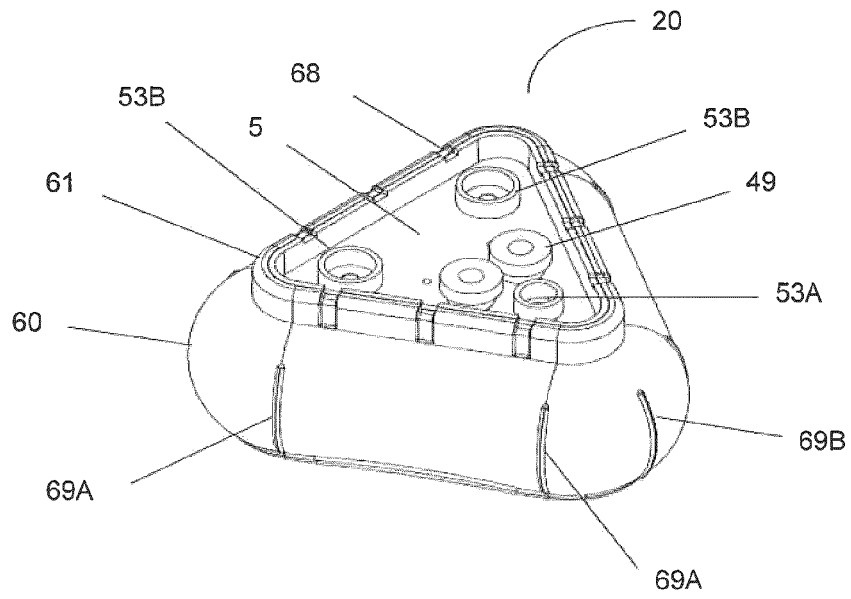

FIG 4

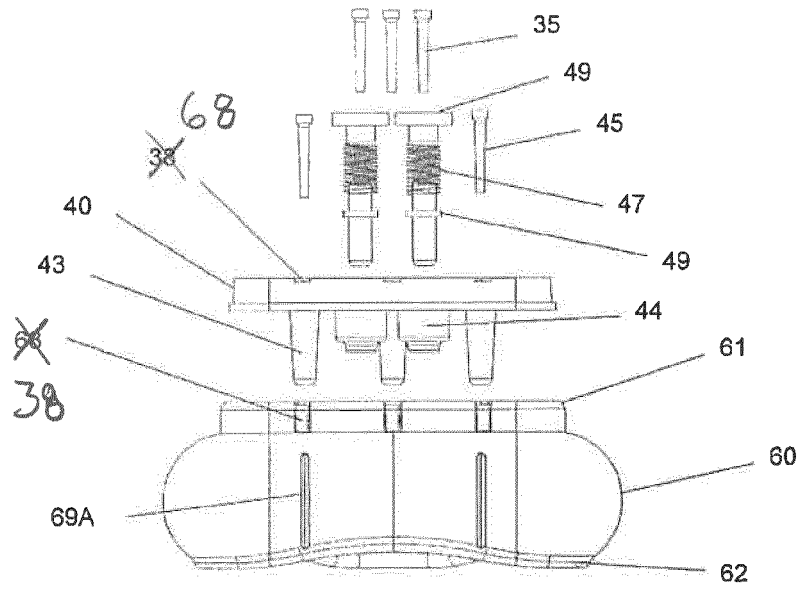

FIG 5

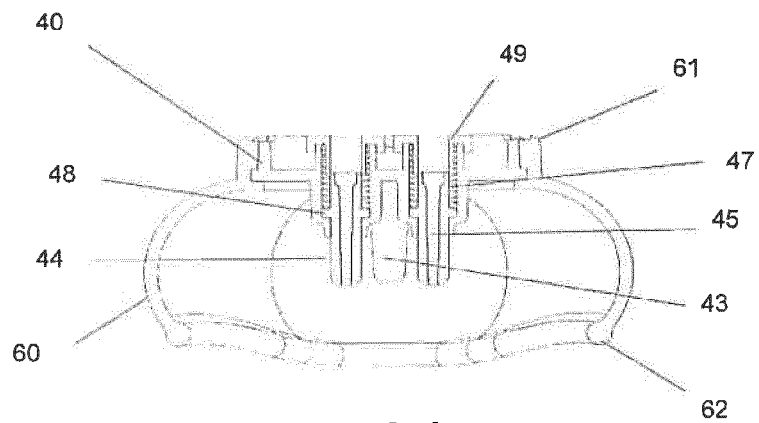

FIG 6

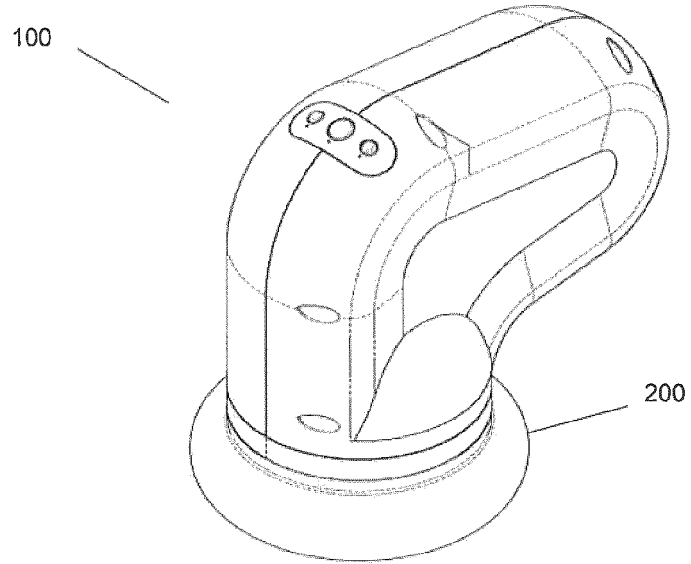

FIG 7A

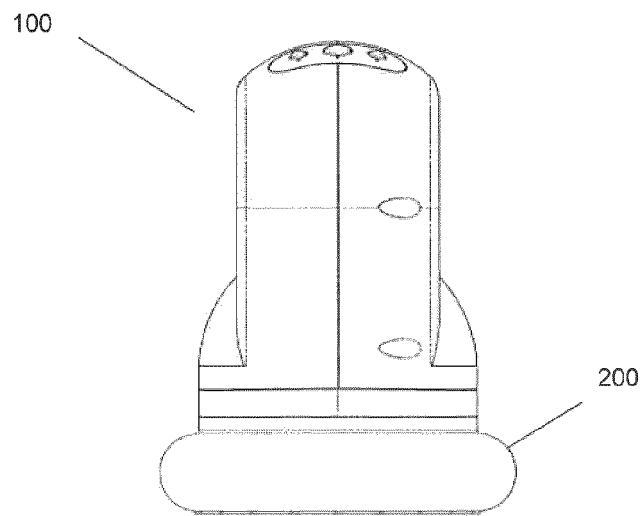

FIG 7B

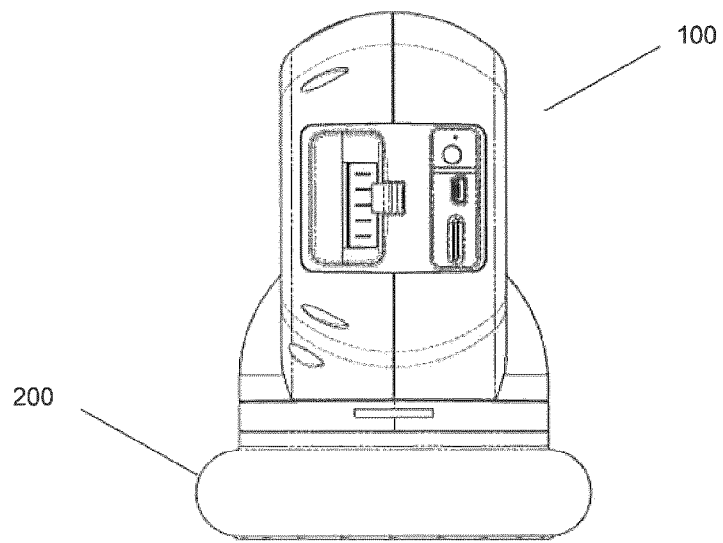

FIG 7C

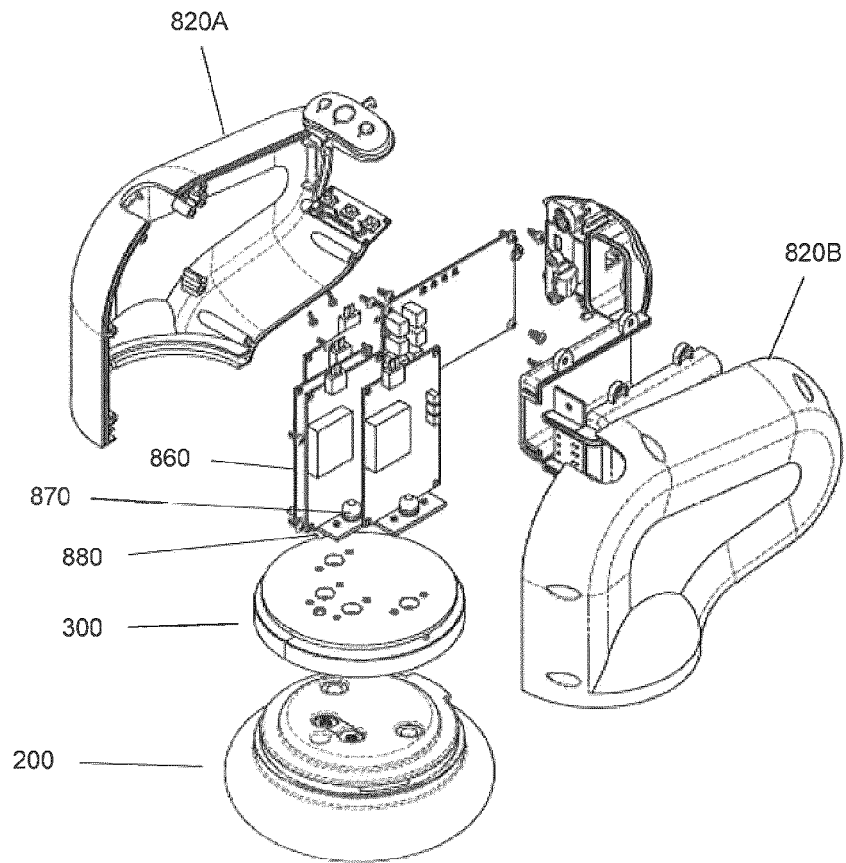

FIG 8

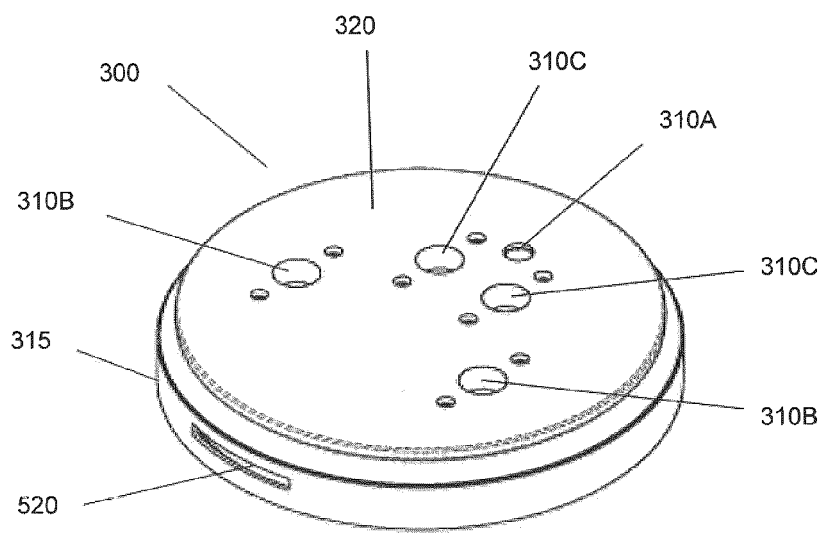

FIG 9

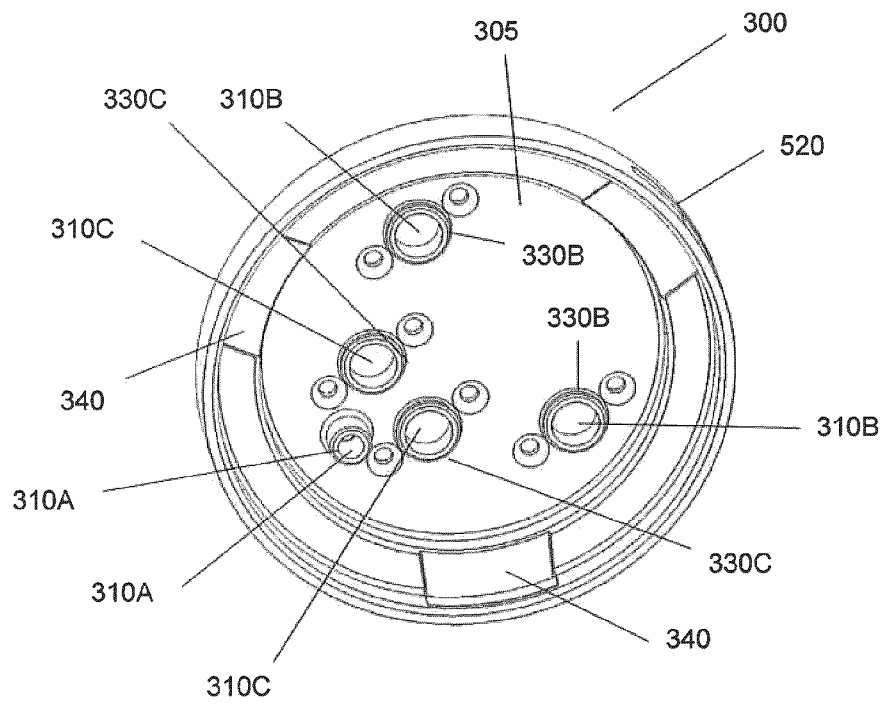

FIG 10

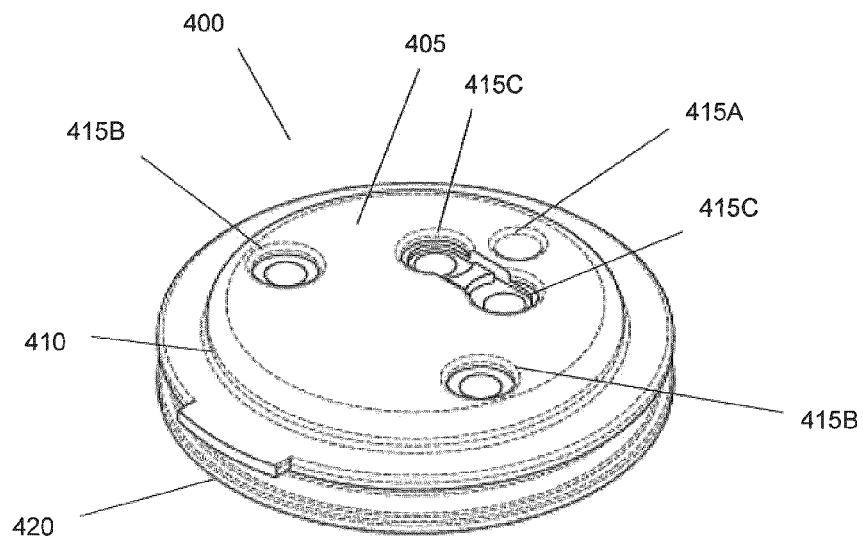

FIG 11

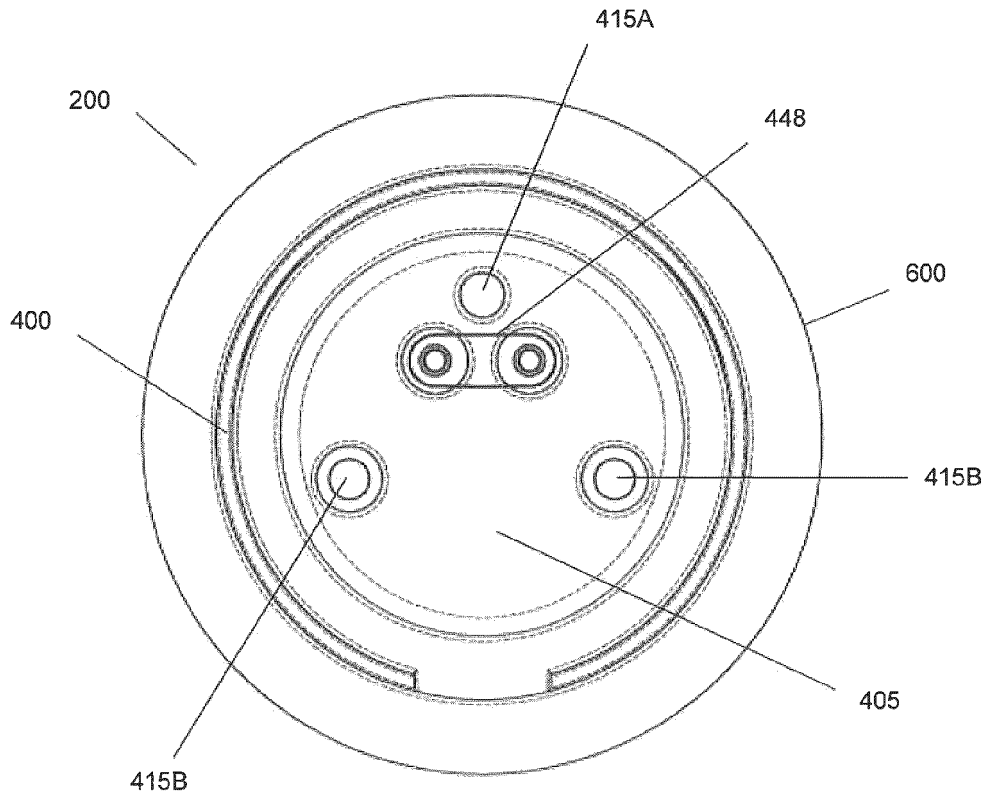

FIG 12A

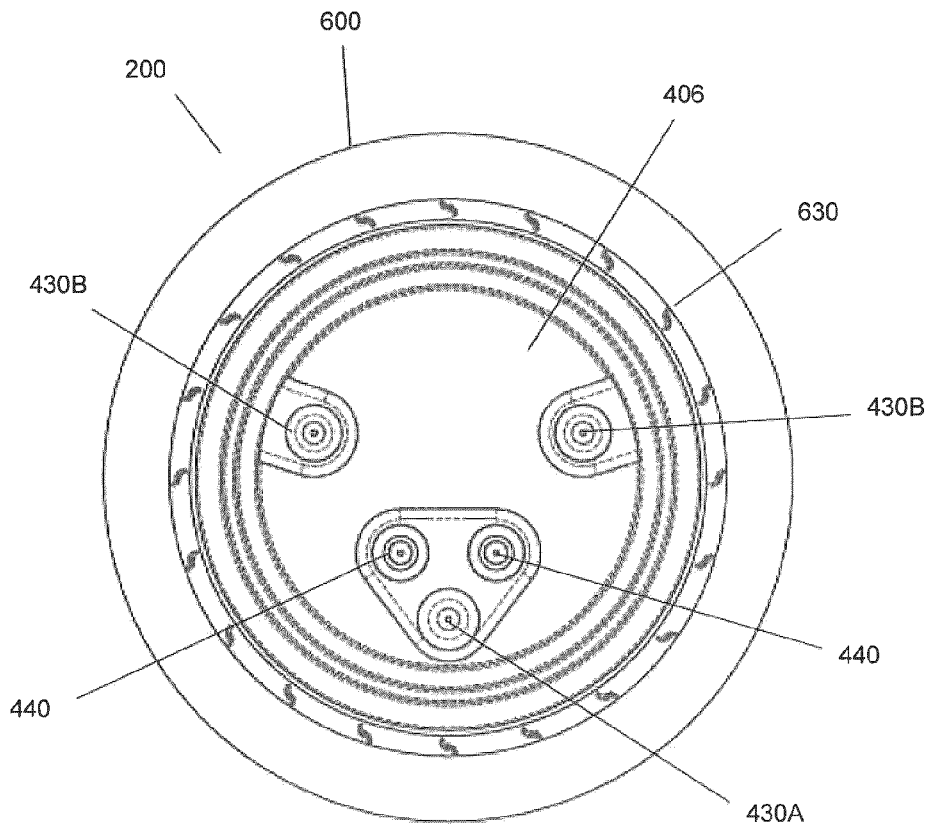

FIG 12B

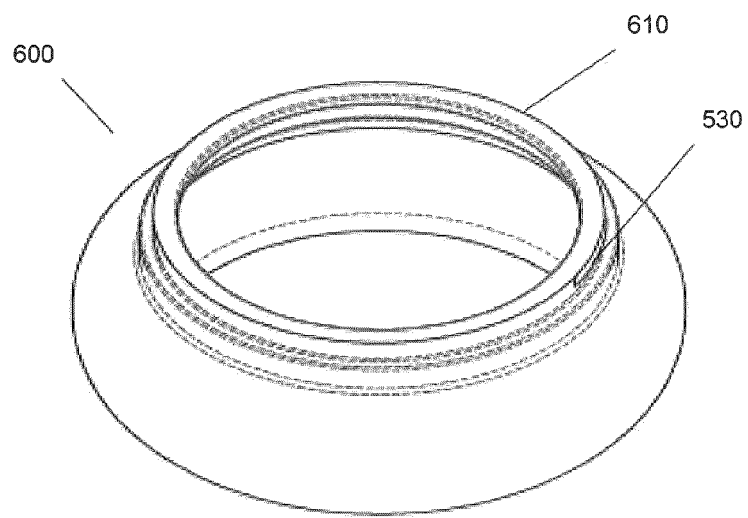

FIG 13

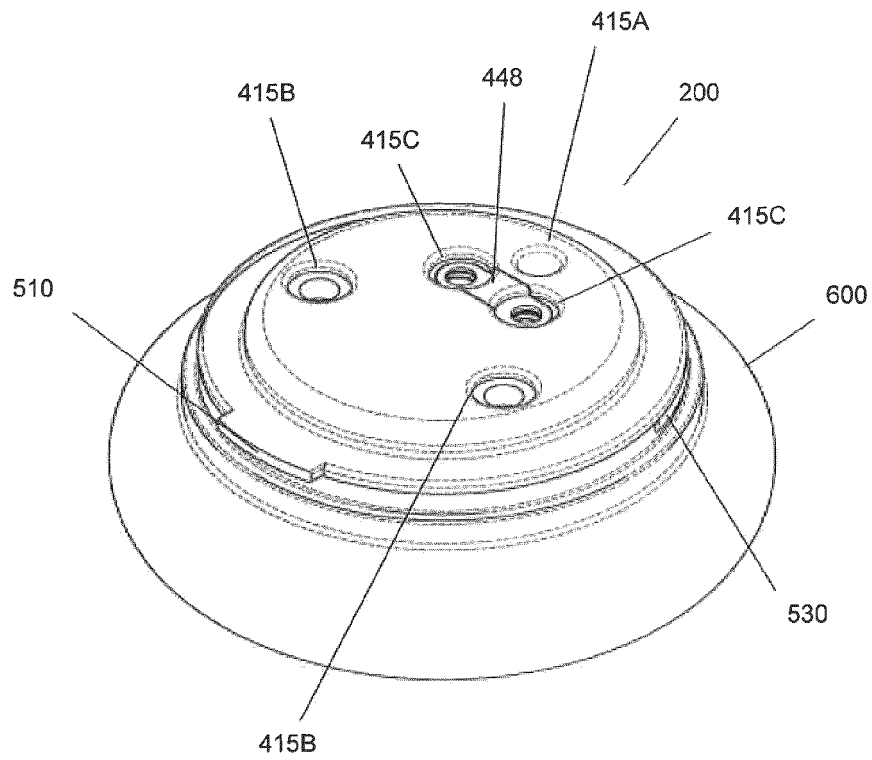

FIG 14

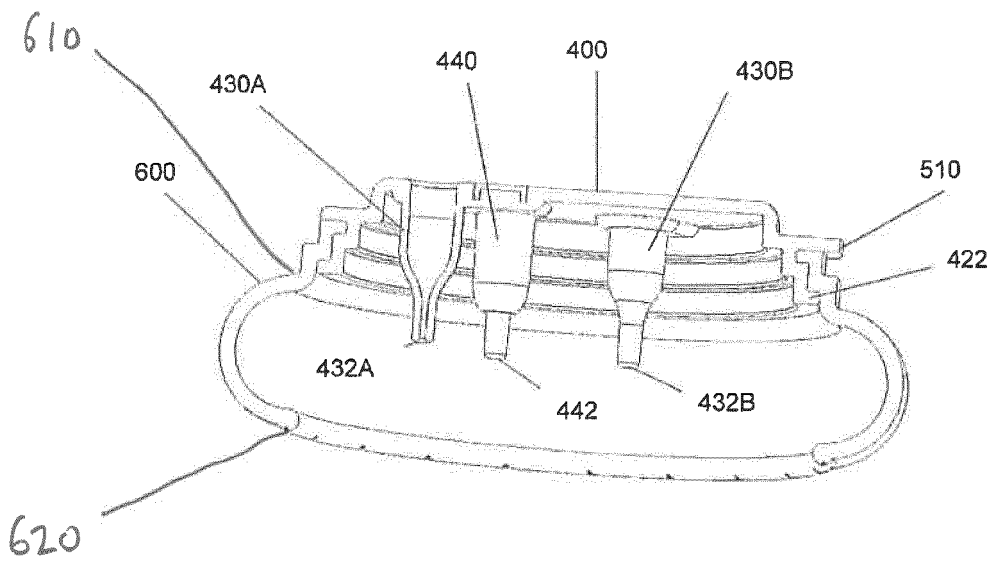
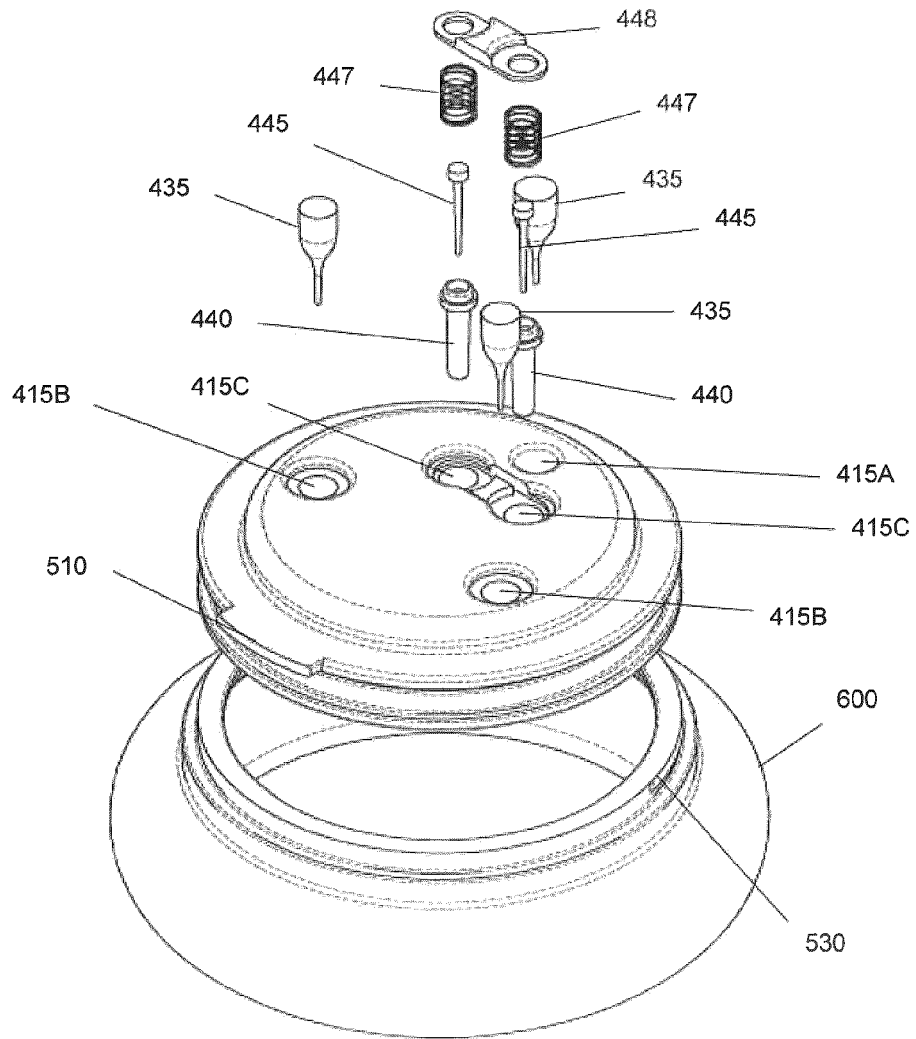

FIG 15



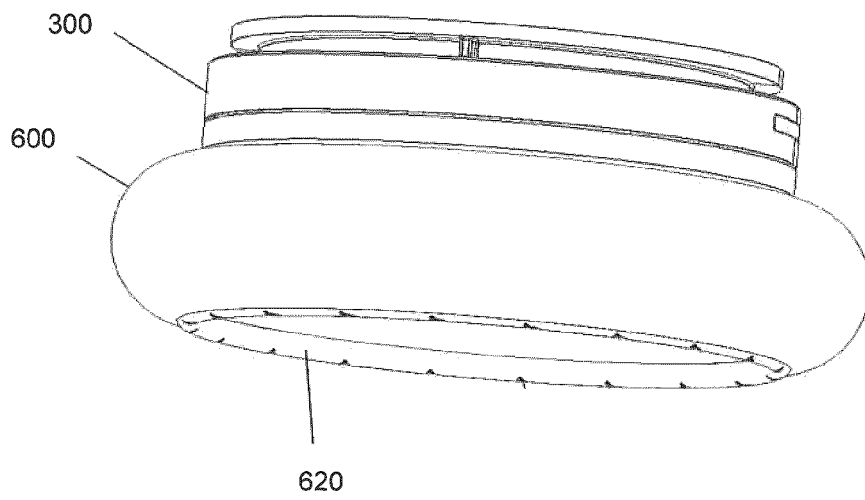

FIG 17

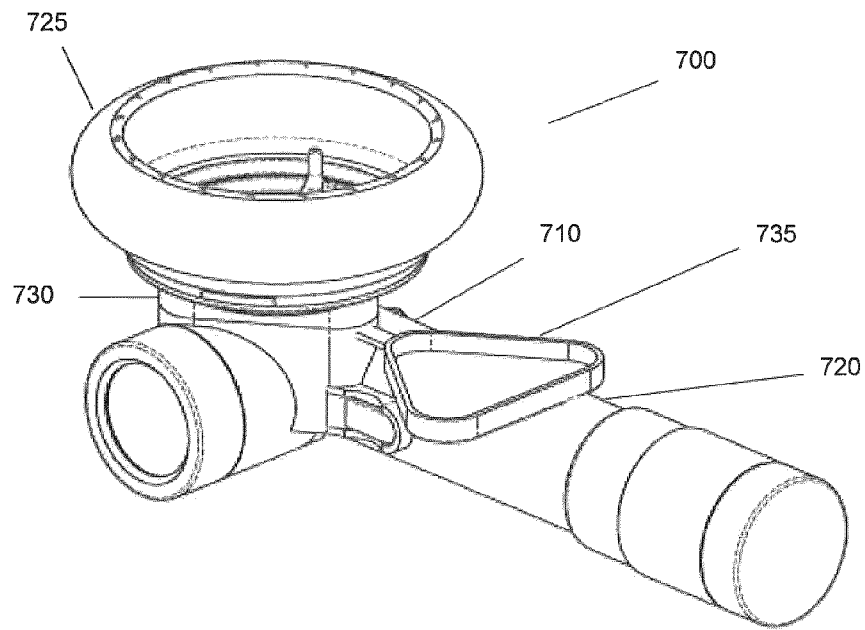

FIG 18

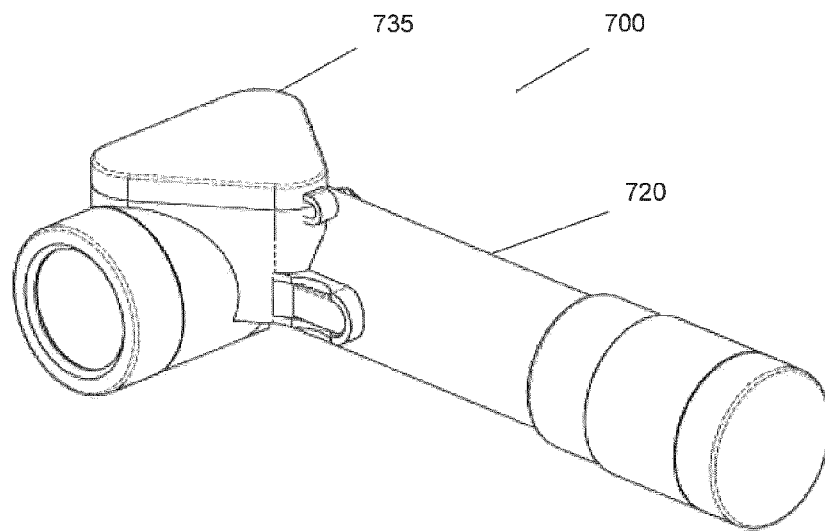

FIG 19

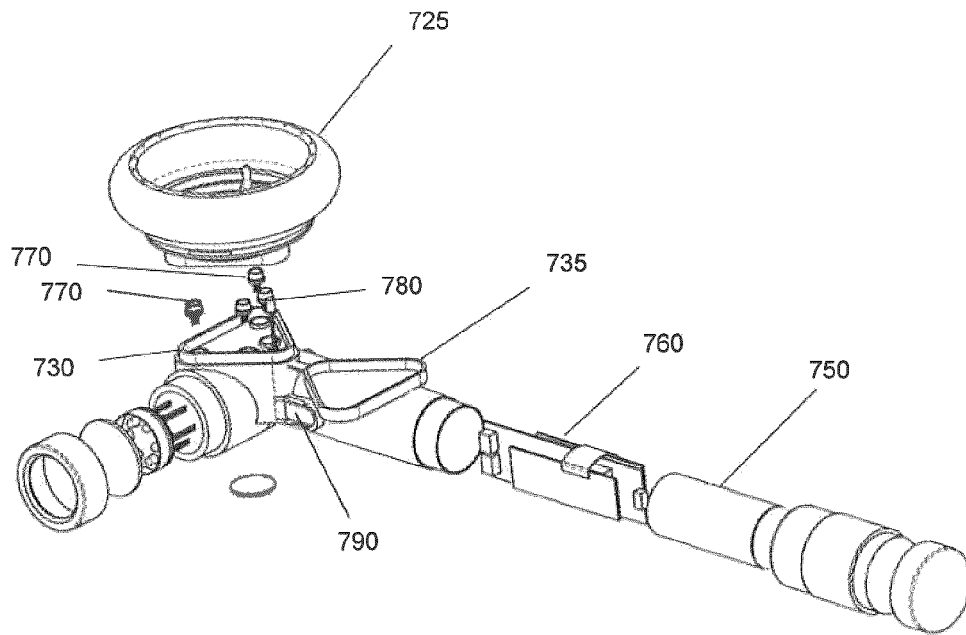

FIG 20

REFERENCES CITED IN THE DESCRIPTION

This list of references cited by the applicant is for the reader's convenience only. It does not form part of the European patent document. Even though great care has been taken in compiling the references, errors or omissions cannot be excluded and the EPO disclaims all liability in this regard.

Patent documents cited in the description

- WO 2006121833 A [0013] [0014]
- WO 2011084480 A [0013] [0015]
- US 2011046491 A [0016]
- US 2013085356 A [0017]

| | | | |
|----------------|---|---------|------------|
| 专利名称(译) | 光学成像装置和帽 | | |
| 公开(公告)号 | EP3274671A4 | 公开(公告)日 | 2018-10-10 |
| 申请号 | EP2016767594 | 申请日 | 2016-03-23 |
| [标]申请(专利权)人(译) | ARCHEOPTIX生物医学 | | |
| 申请(专利权)人(译) | ARCHEOPTIX生物医学INC. | | |
| 当前申请(专利权)人(译) | ARCHEOPTIX生物医学INC. | | |
| [标]发明人 | STRATIS SAVVAS HENDERSON JAMES PATRICK RILEY JASON DAVID RICHARD | | |
| 发明人 | STRATIS, SAVVAS HENDERSON, JAMES PATRICK RILEY, JASON DAVID RICHARD | | |
| IPC分类号 | G01J11/04 A61B5/00 A61B90/00 | | |
| CPC分类号 | A61B5/02042 A61B5/4064 A61B5/6814 A61B2560/0406 A61B2560/0431 A61B2562/146 A61B2562/185 A61B5/0042 A61B5/0066 A61B5/4887 A61B5/7282 | | |
| 优先权 | 62/136781 2015-03-23 US | | |
| 其他公开文献 | EP3274671A1 EP3274671B1 | | |
| 外部链接 | Espacenet | | |

摘要(译)

本发明提供一种可拆卸的光学成像装置帽，用于近红外 (NIR) 光学成像装置，用于检测颅内血肿。