



(11) **EP 2 914 164 B1**

(12) **EUROPEAN PATENT SPECIFICATION**

(45) Date of publication and mention of the grant of the patent:
17.04.2019 Bulletin 2019/16

(51) Int Cl.:
A61B 5/00 (2006.01) A61B 10/02 (2006.01)

(21) Application number: **13821163.6**

(86) International application number:
PCT/IB2013/059712

(22) Date of filing: **28.10.2013**

(87) International publication number:
WO 2014/068468 (08.05.2014 Gazette 2014/19)

(54) **SYSTEM WITH PHOTONIC BIOPSY DEVICE FOR OBTAINING PATHOLOGICAL INFORMATION**

SYSTEM MIT PHOTONISCHER BIOPSIEVORRICHTUNG ZUR GEWINNUNG VON PATHOLOGISCHEN INFORMATIONEN

SYSTÈME AYANT UN DISPOSITIF DE BIOPSIE PHOTONIQUE POUR OBTENIR DES INFORMATIONS PATHOLOGIQUES

(84) Designated Contracting States:
AL AT BE BG CH CY CZ DE DK EE ES FI FR GB GR HR HU IE IS IT LI LT LU LV MC MK MT NL NO PL PT RO RS SE SI SK SM TR

(30) Priority: **02.11.2012 US 201261721541 P**

(43) Date of publication of application:
09.09.2015 Bulletin 2015/37

(73) Proprietors:
• **Koninklijke Philips N.V.**
5656 AE Eindhoven (NL)
Designated Contracting States:
AL AT BE BG CH CY CZ DK EE ES FI FR GB GR HR HU IE IS IT LI LT LU LV MC MK MT NL NO PL PT RO RS SE SI SK SM TR
• **Philips GmbH**
20099 Hamburg (DE)
Designated Contracting States:
DE

(72) Inventors:
• **BIERHOFF, Waltherus Cornelis Jozef**
NL-5656 AE Eindhoven (NL)
• **REICH, Christian**
NL-5656 AE Eindhoven (NL)
• **VAN DER MARK, Martinus Bernardus**
NL-5656 AE Eindhoven (NL)

- **HENDRIKS, Bernardus Hendrikus Wilhelmus**
NL-5656 AE Eindhoven (NL)
- **VAN DE STOLPE, Anja**
NL-5656 AE Eindhoven (NL)
- **VOSS, Stephan**
NL-5656 AE Eindhoven (NL)
- **WINKEL, Axel**
NL-5656 AE Eindhoven (NL)
- **VAN DER VOORT, Marjolein**
NL-5656 AE Eindhoven (NL)
- **PULLY, Vishnu Vardhan**
NL-5656 AE Eindhoven (NL)
- **LUCASSEN, Gerhardus Wilhelmus**
NL-5656 AE Eindhoven (NL)
- **VAN DEN BERG-DAMS, Susanne Dorien**
NL-5656 AE Eindhoven (NL)
- **SPLIETHOFF, Jarich Willem**
NL-5656 AE Eindhoven (NL)

(74) Representative: **Steffen, Thomas**
Philips Intellectual Property & Standards
High Tech Campus 5
5656 AE Eindhoven (NL)

(56) References cited:
US-A1- 2002 128 570 US-A1- 2005 070 818
US-A1- 2005 203 419 US-B1- 6 564 087

EP 2 914 164 B1

Note: Within nine months of the publication of the mention of the grant of the European patent in the European Patent Bulletin, any person may give notice to the European Patent Office of opposition to that patent, in accordance with the Implementing Regulations. Notice of opposition shall not be deemed to have been filed until the opposition fee has been paid. (Art. 99(1) European Patent Convention).

Description

FIELD OF THE INVENTION

5 [0001] The invention generally relates to a system including facilities for in-vivo and for ex-vivo tissue inspection. Particularly, the invention relates to a system including a biopsy device with optical fibers and a lateral notch for in-vivo tissue inspection and for taking a biopsy which may additionally be subjected to ex-vivo tissue inspection.

BACKGROUND OF THE INVENTION

10 [0002] Traditional pathology makes use of ex-vivo analysed tissue samples. As a result some of the relevant information of the in-vivo tissue state, e.g. its metabolic state, is lost in this process and cannot be measured on the tissue slide used for histopathology diagnostics. Biopsies are typically performed by surgeons or interventional radiologists, and subsequently examined by a pathologist. An exemplary workflow for obtaining a biopsy is depicted in figure 1. For positioning the biopsy device (usually a needle with a shaft 100 having a lateral recess 200, and an outer tubular member 500) accurately in the suspicious tissue, the correct location is commonly determined using image guidance such as Ultrasound or X-ray. While imaging may provide coarse guidance of the needle towards the region of interest, it is often challenging to precisely identify the boundaries of small lesions or tumors with the biopsy needle using standard imaging modalities. As a consequence, biopsies are often taken at the wrong location, which increases the risk of false diagnoses. An additional challenge is the heterogeneity present in many tumors where for example multiple biopsies in different regions of the tumor are required, and this requires more accurate positioning in different parts of the tumor tissue. The association between biopsy location and subsequent biopsy histopathology analysis is important to assess the heterogeneity and the optimal (targeted) therapy to choose. This is becoming more important with the increasing use of neoadjuvant cancer therapy, prior to surgery, e.g. in breast cancer.

20 [0003] There are various imaging devices that provide in-vivo information such as functional MRI imaging and PET-CT imaging. Due to the above described difficulties, it is difficult to link information obtained by these imaging modalities to histopathology results from a biopsy slide taken from the body because the link to the exact position of the biopsy is difficult, in part because of limited resolution of the imaging modalities.

25 [0004] In order to position a biopsy needle under image guidance more accurately in the suspicious tissue, tissue sensing at the tip of the device may be required. Current biopsy needles often do not have such tissue feedback possibilities. Recently, elongated interventional devices have been reported with optical fibers integrated into the device which provide feedback from the tissue at the tip of the device. Such devices allow for fine-guidance towards small volumes of suspicious tissue, in particular for tissue which does not show sufficient contrast in imaging. In order to allow tissue discrimination, these devices employ diffuse reflectance spectroscopy (DRS). For DRS, such devices should be designed with the maximum possible distance between the source and detector fibers to ensure an optimal tissue characterization.

30 [0005] Patent application US2005070818A1 is considered the closest prior art to the subject-matter of claim 1 and relates to a biopsy device for collection of a tissue sample from a biopsy site. The biopsy device includes an introducer assembly, a cutter assembly and an endoscope assembly that co-act with each other.

35 [0006] Patent application US2005203419A1 relates to a side-firing probe for performing optical spectroscopy during core needle biopsy. The optical probe includes an illumination optical fiber which conveys light to the tissues adjacent a side window and a detection optical fiber which collects light from the same tissues and conveys it to an optical spectroscopy instrument. Based on the results of the optical spectroscopy measurement, the optical probe may be withdrawn from the needle and a cutter advanced to acquire a sample of the tissues adjacent the side window.

40 [0007] Patent US6564087B1 relates to fiber optic needle probes for optical coherence tomography imaging. A fiber optic needle probe includes a needle, an optical fiber, and a beam director. A portion of the wall of the needle is capable of transmitting light. The beam director directs light from the optical fiber to an internal structure being imaged and receives light from the structure through a transparent portion of the wall. An actuating device moves the needle, optical fiber, or beam director to scan the internal structure of the specimen.

45 [0008] Patent application US2002128570A1 relates to a perfusion sensitive biopsy extractor. A technique for quantifying perfusion and removing a biopsy sample at a site in a living body wherein an instrument having a perfusion sensor is introduced into the body at a site to be investigated to there interrogate the tissue is disclosed. The biopsy specimen is collected when the perfusion sensor produces a signal indicative of perfused, viable tissue.

55 SUMMARY OF THE INVENTION

[0009] Whereas tissue sensing at the tip can ensure that the device is correctly positioned at the location of interest, it is desirable that the biopsy is obtained from exactly the same location. For this, a special design is required to ensure

that the correct tissue sample is captured in the notch of a biopsy device. During tissue measurements, the notch of the biopsy device is at a different location than the position of the fiber ends at the tip of the device. A special construction is required such that when the biopsy is taken after the tissue sensing is completed, the notch of the biopsy device is positioned at the location where the final tissue sensing took place.

5 **[0010]** For biopsy devices with a lateral notch, the presence of the notch sets strict constraints for integrating the optical fibers within the device. Consequently, the fibers would be confined to the lower part of the shaft of the device, resulting in a small and likely insufficient source-detector fiber distance at the tip.

[0011] A biopsy device may consist of several moveable parts, which in the case of a fully-automated biopsy gun are ejected at high speeds with abrupt movements. Accordingly, the optical fibers need to be integrated in a way which ensures their mechanical stability and which does not restrict the usability of the biopsy gun.

10 **[0012]** Further, the typical workflow for obtaining a biopsy should not be changed.

[0013] It may be seen as an object to integrate optical fibers at the tip of a biopsy device (needle) in such a way that (1) the obtained tissue sample (biopsy) is the same as the tissue investigated by optical fibers prior to taking the biopsy, (2) a sufficient source-detector fiber distance can be realized for tissue characterization, and (3) that the modifications do not require a change in the clinical workflow of a standard biopsy procedure. It may be seen as a further object to combine in-vivo information, for example metabolic information to the standard histopathology to obtain an advanced pathology data set, integrating conventional pathology staining results with such information on an individual cellular level, and to provide more complete information on the biological characteristics and behaviour of the cells, relevant for improved diagnostics (including therapy response monitoring).

20 **[0014]** In other words: it is an object of the invention to provide system and method for obtaining in-vivo and ex-vivo pathological information of a single tissue sample, i.e. the same tissue sample. This and further objects are solved by the subject-matter of the independent claim. Further embodiments are described in the dependent claims.

[0015] The invention proposes an integrated solution for adding tissue sensing at the tip of a biopsy device. The biopsy device consists of the optical sensing part at the tip of the device and a shaft with a lateral notch characterized in that the position of optical sensing part before taking the biopsy and the proximal position of the notch when taking the biopsy are substantially the same. Hence when the shaft is pushed forward (as in figure 3B) the notch will fill with tissue that had been sensed in figure 3A.

25 **[0016]** Generally, a system according to an embodiment may comprise a biopsy device with a tubular member, a hollow shaft and an elongated fiber body. The hollow shaft may have a distal end and a shaft portion adjacent the distal end, wherein a laterally (sidewardly) facing notch is formed in that portion of the shaft. The elongated fiber body may include at least one optical fiber, preferably at least two optical fibers, with a distal end.

30 **[0017]** The fiber body may be movably accommodated within the hollow shaft, and the shaft may be movably accommodated within the tubular member, wherein the tubular member is movable between a first position in which the notch is covered by the tubular member, and a second position in which the notch is not covered by the tubular member, and wherein the fiber body is movable between a first position in which the distal end of the optical fiber is located at the distal end of the shaft with the elongated fiber body extending through the notch, and a second position in which the distal end of the at least one optical fiber is located proximally to the notch.

35 **[0018]** Accordingly, the shaft of a biopsy device is formed as a hollow shaft that provides space for inserting an elongated body with integrated optical fibers. During device (needle) positioning, the full volume of the shaft, including the notch, is now occupied by the fiber body and allows for guiding the optical fibers to the tip with a sufficiently large source-detector fiber distance to ensure an accurate tissue characterization.

40 **[0019]** When the biopsy is taken, the fiber body is released from the shaft and the full volume of the notch becomes available for securing the biopsy. Thus, the use within the clinical workflow remains essentially the same as for a conventional biopsy needle, except the added tissue sensing functionality during needle positioning.

45 **[0020]** According to an embodiment, the fiber body comprises a bevel at a distal end of the fiber body, wherein the distal end of the at least one optical fiber is located at the bevel of the fiber body, wherein a smooth surface is formed by the front surface of the optical fiber and the surface of the bevel. Alternatively, the distal end of the at least one optical fiber may protrude beyond the bevel of the fiber body. Alternatively, the distal end of at least one optical fiber may be located inside the fiber body adjacent the bevel. Furthermore, the front surface of the optical fiber may have a different angle than the bevel of the fiber body.

50 **[0021]** A 'bevel' is a geometrical structure allowing for introducing the needle into tissue. Usually, a shaft of a needle includes a circular cross section. The distal end of a needle shaft is cut such that an oval surface is formed, which is inclined relative to the longitudinal axis of the shaft. The bevel forms a pointed tip at the most distal end of the needle. It should be noted that the bevel might form an acute angle with the shaft, such that the needle includes a pointed tip. Preferably, the acute angle might be approximately 20°.

55 **[0022]** According to an embodiment, the bevel of the fiber body together with the slanted surface of the distal end of the hollow shaft may form the geometrical structure allowing for introduction of the device into tissue.

[0023] In the following, geometrical aspects will be defined for a better understanding. First of all, the device includes

a longitudinal main axis, usually the centre axis of a rotationally symmetrical shaft. Further, the tip portion of the device is cut at an angle to the main axis forming the bevel. The pointed tip of the bevel is directed to the 'front' of the needle. As a result, looking from the 'side', it is possible to recognize the angle between the bevel and the main axis, and further it is possible to look onto and into a recess formed at the side, i.e. laterally.

5 **[0024]** It should be noted that the end surface of a fiber at the opening in the bevel may have a circular shape or an oval shape in case of a substantially circular cross section of the fiber. Depending on the angle at which the fiber will end at the bevel surface, the shape of the end surface of the fiber will be effected and therefore also the direction of the emitted or received light.

10 **[0025]** The fiber body has an outer diameter, and the end surfaces of the fibers are arranged within the body at a distance to each other. Preferably, the distance between the fiber ends is greater than the diameter of the body. For example, the distance is more than 1.1 times greater than the diameter. Particularly, the distance may be more than 1.25 times greater than the diameter. Preferably, the distance may be more than 1.5 times greater than the diameter. In other words, the distance between the fiber ends should be as great as possible. Such distances are measured from the central axis of one of the fibers to the central axis of the other one of the fibers.

15 **[0026]** It will be understood that the tubular member may include a sharpened distal edge.

20 **[0027]** According to a further embodiment, an insert may be arranged within the hollow shaft between the distal end of the hollow shaft and the notch, wherein the insert may include openings for accommodating the distal end of the at least one optical fiber, when the fiber body is in the first position, i.e. when the fiber body is in a position in which the distal end of the optical fiber(s) is located at the distal end of the shaft with the elongated fiber body extending through the notch.

[0028] According to another embodiment, the biopsy device may further comprise a channel for injecting or extracting a fluid. Such a channel may be an additional channel formed in the fiber body and extending through that body in a longitudinal direction, but may also be formed in the wall of the shaft or between the fiber body and the shaft or between the shaft and the outer tubular member.

25 **[0029]** According to a further embodiment, the biopsy device may further comprise a tissue retraction channel, wherein a suction device may apply vacuum to the channel for retracting a sample of tissue. For example, the channel in which the fiber body is accommodated within the shaft, may be used for retracting a sample, after removing the fiber body. Alternatively, the channel may be formed in the fiber body between optical fibers which are preferably arranged as much as possible at opposite sides of the elongated body.

30 **[0030]** According to another embodiment, the biopsy device further comprises a console including a light source, a light detector and a processing unit for processing the signals provided by the light detector, wherein one of the light source and the light detector may provide wavelength selectivity. The light source may be one of a laser, a light-emitting diode or a filtered light source, and the console may further comprise one of a fiber switch, a beam splitter or a dichroic beam combiner. Furthermore, the device may be adapted to perform at least one out of the group consisting of diffuse reflectance spectroscopy, diffuse optical tomography, differential path length spectroscopy, and Raman spectroscopy.

35 **[0031]** The system may further comprise a device adapted for ex-vivo tissue inspection, and/or a storage container for receiving an extracted tissue sample and for storing pathology information obtained by an in-vivo tissue inspection and/or an ex-vivo tissue inspection.

40 **[0032]** According to another aspect, a method for obtaining pathological information regarding a tissue sample is provided, the method generally comprising the steps of obtaining information from an in-vivo tissue inspection, obtaining information from an ex-vivo tissue inspection, wherein the same tissue sample is inspected firstly in-vivo and then ex-vivo.

[0033] The in-vivo tissue inspection may include at least one out of the group consisting of diffuse reflectance spectroscopy, diffuse optical tomography, differential path length spectroscopy, and Raman spectroscopy. On the other hand, the ex-vivo tissue inspection may include at least one of making tissue slices, staining by Hematoxylin and eosin (H&E) and/or a specific biomarker, and optically scanning.

45 **[0034]** According to an embodiment, the method may further comprise the step of integrating the information obtained by in-vivo tissue inspection and the information obtained by ex-vivo tissue inspection. For example, the in-vivo obtained information may be used for an interpretation of the ex-vivo obtained information.

50 **[0035]** The method may further comprise the step of storing the pathology information of the tissue sample, obtained by the in-vivo tissue inspection and/or by the ex-vivo tissue inspection, by a storage containing which may also be adapted to receive a tissue sample.

55 **[0036]** The aspects defined above and further aspects, features and advantages of the present invention may also be derived from the examples of embodiments to be described hereinafter and are explained with reference to examples of embodiments. The invention will be described in more detail hereinafter with reference to examples of embodiments but to which the invention is not limited.

BRIEF DESCRIPTION OF THE DRAWINGS

[0037]

- 5 Fig 1 is an illustration of taking a biopsy with a known needle.
 Fig. 2 shows a biopsy device according to a first embodiment.
 Fig. 3 illustrates steps of taking a biopsy with a device of fig. 2.
 Fig. 4 shows a biopsy device according to a second embodiment.
 Fig. 5 illustrates steps of taking a biopsy with a device of fig. 3.
 10 Fig. 6 shows a system including a biopsy device and a console.
 Fig. 7 shows a log plot of absorption coefficient of blood, water and fat.
 Fig. 8 shows fluorescence curves for collagen, elastin, NADH and FAD.
 Fig. 9 is a flow chart illustrating steps of a method according to an embodiment.

- 15 **[0038]** The illustration in the drawings is schematically only and not to scale. It is noted that similar elements are provided with the same reference signs in different figures, if appropriate.

DETAILED DESCRIPTION OF EMBODIMENTS

- 20 **[0039]** In figure 2, a first embodiment of a biopsy device is shown, having a hollow shaft 10, fiber body 35 and an outer tubular member 50. The hollow shaft 10 includes a distal end or tip 15 forming a slanted surface, wherein the slanted surface may have an oval shape in case the hollow shaft has a circular cross section. Furthermore, a lateral recess or notch 20 is formed in the shaft, wherein the notch 20 is substantially formed by a lateral opening and a section of the bore extending through the shaft in a longitudinal direction.

- 25 **[0040]** The fiber body 35 is formed by an elongated and solid element in which channels for accommodating optical fibers 40 are provided. The fiber body includes a bevel 30 at the distal end thereof. The outer tubular member 50 comprises a sharpened distal edge. For a better visualization, the fiber body is in figure 2 in an intermediate position with the bevel 30 within the notch 20.

- 30 **[0041]** For tissue sensing, an optical fiber 40 for illumination and collecting light is required with distal end at the tip 15 of the biopsy device. The proximal end of the fiber may be connected to an optical console capable of sending and receiving light.

- 35 **[0042]** For optimal tissue sensing, it is required to guide at least two optical fibers 40 (source and detector) towards the device tip 15, and the fiber tip ends should have a maximized distance from each other. According to the first embodiment, this is achieved by a hollow shaft providing space for inserting a fiber body 35 with optical fibers 40 integrated at a sufficient source-detector fiber distance at the tip, i.e. at the bevel 30.

- 40 **[0043]** In a typical clinical workflow, the biopsy device is inserted into the patient with the outer tubular member 50 (the cutting cannula) covering the notch 20 of the shaft 10 to ensure a smooth protrusion (step A in figure 3). Hence the notch 20 is not exposed to the tissue in this step, and the hollow space in the shaft 10 (including the notch 20) can be occupied by the fiber body without altering the workflow. The proposed solution allows for additional tissue characterization at the tip during needle positioning.

- [0044]** At the target location, the shaft 10 is ejected whereas the fiber body 35 remains in its position (step B in figure 3). Thereby, the notch 20 is no longer occupied by the tubular member 50 and the biopsy can be obtained in a conventional way (step C in figure 3).

- 45 **[0045]** Whereas the hollow shaft 10 and the tubular member 50 are moveable parts, the fiber body may remain at a fixed position during the entire procedure. Since the fiber body 35 with the integrated optical fibers 40 is not moved, the design is compatible with fast (fully-automated) shooting mechanisms, where the workflow steps B and C are successively executed at high speed. Thus, the risk of damaging the optical fibers 40 by strong mechanical forces can be circumvented.

- 50 **[0046]** The length and position of the shaft 10 may be chosen in such a way that the fiber body 35 is facing the proximal side of the notch 20 when exposed after the ejection (step B). This allows for a direct characterization of the tissue present in the notch 20, just before the biopsy is taken (step C). With this option, a confirmation measurement from the tissue in the notch can be performed in-situ, and an optimal correlation between the biopsy sample and the optical measurement can be ensured. This is particularly useful for biopsy devices with a manual or semi-automated shooting mechanism, where the workflow steps 2 and 3 can be executed with a user-defined time delay to allow for additional tissue measurements in the notch.

- 55 **[0047]** Figure 4 shows a second embodiment of a biopsy device which differs from the first embodiment in that an insert 12 is inserted in the portion of the hollow shaft 10 between the distal end 15 and the notch 20. The insert 12 may be a small fixed element at the tip by means of which the tip of the hollow shaft may be closed during biopsy. For a better visualization, the fiber body is in figure 4 in an intermediate position with the protruding ends of the optical fibers

40 within the notch 20.

[0048] During ejection of the shaft 10, tissue may enter the hollow tip portion of the shaft and may be cut by the protruding shaft with the hole (step B). An insert 12 may ensure that the amount of tissue being cut is only the absolute minimum that is medically required for obtaining a proper biopsy.

[0049] The insert 12 has two or more (conical) openings / channels 13 which are just large enough (typically some 100 μ m) for loosely guiding the optical fibers 40 towards the tip 15 of the shaft 10. The fiber body 35 is adapted accordingly, so that the optical fibers 40 protrude a well-defined extent out of the body to fit into the guiding channels 13 of the insert 12. Preferably, the dimensions of the insert are minimized (some millimetres only) to reduce the required protrusion length of the optical fibers 40 from the body of the fiber body 35.

[0050] Furthermore, a small opening for applying vacuum can be realized within the shaft or in the fiber body, and it may be used for sucking tissue into the notch 20 after the shaft 10 has been ejected (step B) to ensure that the biopsy is of sufficient size. By way of this, the underpressure may ensure that the tissue is brought in close contact with the optical fibers 40 facing the proximal side of the exposed notch 20, for the case that the tissue in the notch is characterized prior to obtaining the biopsy.

[0051] Such an opening 45 is schematically illustrated in figure 2, wherein this opening may be formed within the shaft 10, within the fiber body 35, but also as a gap between the shaft 10 and the fiber body 35.

[0052] The incorporation of a small opening for applying underpressure can also allow for simultaneous biological/physiological analysis of the blood/tissue under consideration, thus obtaining a better biopsy quality. The underpressure can be used to suck in small amounts (microliter) of body fluid (for instance blood/serum, bile, or else) for instant biochemical analysis, which can be used to complement the optical tissue characterization.

[0053] For this, the underpressure is preferably realized by a small vacuum opening within the fiber body, so that the blood sampling can be performed within the described design at the tip (workflow step A in figure 3) and also in the notch (step B in figure 3). The absorbed blood/cells could be analyzed by appropriate detectors (such as chip-sized microfluidic devices and/or MEMS) connected to the distal end of the vacuum channel, thereby enabling instantaneous analysis.

[0054] For instance, MEMS-based pH sensors could allow for complementary classification of tumor (acidic) vs. normal (basic) tissue based on pH. Apart from pH sensors, also other specific sensors may be used that could characterize the tissue sample in consideration. This could serve as complimentary means to support the optical tissue sensing in difficult cases, and thereby improve the results of photonic biopsy procedures even further.

[0055] It is noted that the 'bevel' might also have another shape or structure at the tip of the device, useful for introducing the device into a tissue. For example, the bevel might be a convex or concave surface, or the bevel might be a combination of several small surfaces, wherein these surfaces are connected to each other by steps or edges. It might also be possible that the cross section of the shaft is not completely cut by the bevel, such that an area remains which is blunt, i.e. is for example perpendicularly orientated relative to the longitudinal axis of the shaft. Such a 'blunt' end might include rounded edges or might also form a rounded leading edge. As another example, a sharp edge might be formed by two or more slanted surfaces being symmetrically or asymmetrically arranged to form the tip of the device.

[0056] As shown in figure 6, the fibers 40 of the interventional device are connected to an optical console 60. The optical fibers can be understood as light guides or optical waveguides. In an embodiment, the console 60 comprises a light source 64 in the form of a halogen broadband light source with an embedded shutter, and an optical detector 66. The optical detector 66 can resolve light with a wavelength substantially in the visible and infrared regions of the wavelength spectrum, such as from 400 nm to 1700 nm. The combination of light source 64 and detector 66 allows for diffuse reflectance measurements. For a detailed discussion on diffuse reflectance measurements see R. Nachabe, B.H.W. Hendriks, A.E. Desjardins, M. van der Voort, M.B. van der Mark, and H.J.C.M. Sterenborg, "Estimation of lipid and water concentrations in scattering media with diffuse optical spectroscopy from 900 to 1600nm", J. Biomed. Opt. 15, 037015 (2010).

[0057] Optionally it is also possible that the console is couple to an imaging modality capable of imaging the interior of the body, for instance when the biopsy is taken under image guidance. In this case it is also possible to store the image of the interior when the biopsy is taken to a container of the biopsy. In this case the in-vivo information of the optical biopsy needle, the information of the pathology of the biopsy as well as the location where the biopsy was taken are brought together for advanced pathology.

[0058] On the other hand, also other optical methods can be envisioned like diffuse optical tomography by employing a plurality of optical fibers, differential path length spectroscopy, fluorescence and Raman spectroscopy to extract tissue properties.

[0059] Further shown in figure 6 are a suction device 70, a device 80 for obtaining ex-vivo pathology information, and a storage container 90. The suction device may be connected to a proximal end of the biopsy device, such that underpressure or a vacuum can be applied through the biopsy device to the distal end of the same, in particular to the notch at the distal end of the biopsy device.

[0060] The device 80 may be connected to the console 60 by means of a wire or wireless, for interchanging information

like control commands or data representing pathological aspects of an inspected tissue sample. The device 80 may be a digital pathology systems consisting of an optical scanner and an image management system to enable digitizing, storage, retrieval, and processing of tissue staining images, reading the information stored in the storage box container, and integrating this information with the digitized staining data set, to be presented to the pathologist. In addition to this, the data set from the photonic biopsy device may be either presented next to the histopathology image or the two data sets may be fused in the image, characterized and recognizable by a certain coloring pattern of the image. For instance the oxygenation level measured in-vivo could be added as a red color, where deep red means low oxygenation and bright red would mean high oxygenation level. Additionally, molecular spatial distributions from FTIR or Raman could be added as a color coded mapping to the pathology slide of specific molecules.

[0061] The tissue sample, which may firstly be subjected to an in-vivo tissue inspection, i.e. an inspection within a living body, and which may secondly subjected to an ex-vivo tissue inspection by means of the device 80, may be situated in the container 90. Molecular diagnostics can also be performed on the tissue biopsy (e.g. sequencing or PCR), or part of the biopsy

[0062] The storage container for the biopsy may further be such that the optical information obtained in-vivo and/or ex-vivo can be stored on it. This can be a barcode label which can be read at the pathology department by the digital pathology device. It can also be a micro chip where the optical information can be stored electronically. Instead of storing the actual information it is also possible to store an "address" or "link" of where the information may be retrieved.

[0063] According to another embodiment, the container 80 may be placed in the console 60. The data can then be written on the container while the photonic biopsy device is attached to the console. The data can be written in the form of a barcode or can electronically be stored in the chip on the container.

[0064] A processor transforms the measured spectrum into physiological parameters that are indicative for the tissue state and a monitor 68 may be used to visualize the results.

[0065] A computer program executable on the processor may be provided on a suitable medium such as an optical storage medium or a solid-state medium supplied together with or as part of the processor, but may also be distributed in other forms, such as via the Internet or other wired or wireless telecommunication systems.

[0066] For fluorescence measurements the console must be capable of providing excitation light to at least one source fiber while detecting tissue-generated fluorescence through one or more detection fibers. The excitation light source may be a laser (e.g. a semiconductor laser), a light-emitting diode (LED) or a filtered light source, such as a filtered mercury lamp. In general, the wavelengths emitted by the excitation light source are shorter than the range of wavelengths of the fluorescence that is to be detected. It is preferable to filter out the excitation light using a detection filter in order to avoid possible overload of the detector by the excitation light. A wavelength-selective detector, e.g. a spectrometer, is required when multiple fluorescent entities are present that need to be distinguished from each other.

[0067] In case fluorescence measurements are to be combined with diffuse reflectance measurements, the excitation light for measuring fluorescence may be provided to the same source fiber as the light for diffuse reflectance. This may be accomplished by, e.g., using a fiber switch, or a beam splitter or dichroic beam combiner with focusing optics. Alternatively, separate fibers may be used for providing fluorescence excitation light and light for diffuse reflectance measurements.

[0068] To perform spectroscopy, the acquired spectra may be fitted using a custom made Matlab 7.9.0 (Mathworks, Natick, MA) algorithm. In this algorithm, a widely accepted analytical model was implemented, namely the model introduced by the reference T.J.Farrel, M.S.Patterson and B.C.Wilson, "A diffusion theory model of spatially resolved, steady-state diffuse reflectance for the non-invasive determination of tissue optical properties", Med.Phys. 19 (1992) p.879-888. The input arguments for the model of this reference are the absorption coefficient $\mu_a(\lambda)$, the reduced scattering coefficient $\mu'_s(\lambda)$ and the center-to-center distance between the emitting and collecting fibers at the tip of the probe.

[0069] In the following part, the model will be explained briefly. The used formulas are mainly based on work of Nachabe et al., and reference is thus made to R.Nachabe, B.H.W. Hendriks, M. van der Voort, A.E., and H.J.C.M. Sterenberg "Estimation of biological chromophores using diffuse optical spectroscopy: benefit of extending the UV-VIS wavelength range to include 1000 to 1600 nm", Optics Express, vol. 18, 2010, pp. 1432-1442, and furthermore reference is made to R. Nachabe, B.H.W. Hendriks, A.E. Desjardins, M. van der Voort, M.B. van der Mark, and H.J.C.M. Sterenberg, "Estimation of lipid and water concentrations in scattering media with diffuse optical spectroscopy from 900 to 1600nm", J. Biomed. Opt. 15, 037015 (2010).

[0070] A double power law function can be used to describe the wavelength dependence of the reduced scattering, where the wavelength λ is expressed in nm and is normalized to a wavelength value of $\lambda_0 = 800$ nm. The parameter α corresponds to the reduced scattering amplitude at this specific wavelength.

$$\mu_s(\lambda) = \alpha \left(\rho_{MR} \left(\frac{\lambda}{\lambda_0} \right)^{-b} + (1 - \rho_{MR}) \left(\frac{\lambda}{\lambda_0} \right)^{-4} \right) [cm^{-1}] \quad (\text{Eq. 1})$$

[0071] In this equation the reduced scattering coefficient is expressed as the sum of Mie and Rayleigh scattering where ρ_{MR} is the Mie-to-total reduced scattering fraction. The reduced scattering slope of the Mie scattering is denoted b and is related to the particle size. For a homogeneous distribution of absorbers, the total light absorption coefficient $\mu_a(\lambda)$ can be computed as products of the extinction coefficients and volume fraction of the absorbers (see Figure 8)

$$\mu_a^{Total} = f_1\mu_a^1 + f_2\mu_a^2 + f_3\mu_a^3 + \dots \quad (\text{Eq. 2})$$

[0072] Instead of modeling the absorption coefficient $\mu_a(\lambda)$ as the sum of absorption coefficients weighted by the respective concentrations of the four chromophores of interest, it was decided to express the tissue absorption coefficient as

$$\mu_a^{Tissue}(\lambda) = C(\lambda)v_{Blood}\mu_a^{Blood}(\lambda) + v_{WL}\mu_a^{WL}(\lambda) [cm^{-1}] \quad (\text{Eq. 3})$$

where $\mu_a^{Blood}(\lambda)$ corresponds to the absorption by blood and $\mu_a^{WL}(\lambda)$ corresponds to absorption by water and lipid together in the probed volume. The volume fraction of water and lipid is $v_{WL} = [Lipid] + [H_2O]$, whereas v_{Blood} represents the blood volume fraction for a concentration of hemoglobin in whole blood of 150 mg/ml.

[0073] The factor C is a wavelength dependent correction factor that accounts for the effect of pigment packaging and alters for the shape of the absorption spectrum. This effect can be explained by the fact that blood in tissue is confined to a very small fraction of the overall volume, namely blood vessels. Red blood cells near the center of the vessel therefore absorb less light than those at the periphery. Effectively, when distributed homogeneously within the tissue, fewer red blood cells would produce the same absorption as the actual number of red blood cells distributed in discrete vessels. The correction factor can be described as

$$C(\lambda) = \frac{1 - \exp(-2R\mu_a^{Blood}(\lambda))}{2R\mu_a^{Blood}(\lambda)} \quad (\text{Eq. 4})$$

where R denotes the average vessel radius expressed in cm. The absorption coefficient related to blood is given by

$$\mu_a^{Blood}(\lambda) = \alpha_{BL}\mu_a^{HbO_2}(\lambda) + (1 - \alpha_{BL})\mu_a^{Hb}(\lambda) [cm^{-1}] \quad (\text{Eq. 5})$$

where $\mu_a^{HbO_2}(\lambda)$ and $\mu_a^{Hb}(\lambda)$ represent the basic extinction coefficient spectra of oxygenated hemoglobin HbO_2 and deoxygenated hemoglobin Hb , respectively. The oxygenated hemoglobin fraction in the total amount of hemoglobin is noted $\alpha_{BL} = [HbO_2]/([HbO_2] + [Hb])$ and is commonly known as the blood oxygen saturation. The absorption due to the presence of water and lipid in the measured tissue is defined as

$$\mu_a^{WL}(\lambda) = \alpha_{WL}\mu_a^{Lipid}(\lambda) + (1 - \alpha_{WL})\mu_a^{H_2O}(\lambda) [cm^{-1}] \quad (\text{Eq. 6})$$

[0074] In this case the concentration of lipid related to the total concentration of lipid and water together can be written as $\alpha_{WF} = [Lipid]/([Lipid] + [H_2O])$, where $[Lipid]$ and $[H_2O]$ correspond to the concentration of lipid (density of 0.86g/ml) and water, respectively.

[0075] This way of relating the water and lipid parameters in the expression of the absorption coefficient defined in Eq.6, rather than estimating separately the water and lipid volume fraction corresponds to a minimization of the covariance of the basic functions for fitting resulting in a more stable fit cf. the reference R.Nachabe, B.H.W. Hendriks, M. van der Voort, A.E., and H.J.C.M. Sterenborg "Estimation of biological chromophores using diffuse optical spectroscopy: benefit of extending the UV-VIS wavelength range to include 1000 to 1600 nm", Optics Express, vol. 18, 2010, pp. 1432-1442. For further explanation and validation of this theorem reference is made to the reference R. Nachabe, B.H.W. Hendriks, A.E. Desjardins, M. van der Voort, M.B. van der Mark, and H.J.C.M. Sterenborg, "Estimation of lipid and water concentrations in scattering media with diffuse optical spectroscopy from 900 to 1600nm", J. Biomed. Opt. 15, 037015 (2010).

[0076] For example by means of the described algorithm optical tissue properties may be derived such as the scattering coefficient and absorption coefficient of different tissue chromophores: e.g. hemoglobin, oxygenated haemoglobin, water,

fat etc. These properties are different between normal healthy tissue and diseased (cancerous) tissue.

[0077] The main absorbing constituents in normal tissue dominating the absorption in the visible and near-infrared range are blood (i.e. hemoglobin), water and fat. In figure 8 the absorption coefficient of these chromophores as a function of the wavelength are presented. Note that blood dominates the absorption in the visible range, while water and fat dominate in the near infrared range.

[0078] The total absorption coefficient is a linear combination of the absorption coefficients of for instance blood, water and fat (hence for each component the value of that shown in figure 7 multiplied by its volume fraction). By fitting the model to the measurement while using the power law for scattering, the volume fractions of the blood, water and fat as well as the scattering coefficient may be determined.

[0079] Another way to discriminate differences in spectra is by making use of a principal components analysis. This method allows classification of differences in spectra and thus allows discrimination between tissues. Apart from diffuse reflectance also fluorescence may be measured. Then for instance parameters like collagen, elastin, NADH and FAD could be measured too (see figure 8). Especially, the ratio NADH/FAD, which is called the optical redox parameter, is of interest because it is an indicator for the metabolic state of the tissue, as described in Zhang Q., et al. "Turbidity-free fluorescence spectroscopy of biological tissue", Opt. Lett., 2000 25(19), p. 1451-1453, which is changed in cancer cells and assumed to change upon effective treatment of cancer cells.

[0080] It is also possible to detect the response of the body to exogenous fluorophores that can be detected by the optical biopsy device. Furthermore, these could also be linked to measurements of the exogenous fluorophores by imaging modalities like optical mammography based on diffuse optical imaging.

[0081] The described devices can be used in minimally invasive needle interventions such as low-back pain interventions or taking biopsies in the field of cancer diagnosis or in case where tissue characterization around the needle is required.

[0082] In the following, exemplary needle devices will be described with respect to their outer diameter, their insertion length, and their preferred use.

[0083] A biopsy needle might have an outer diameter of 1.27 mm up to 2.108 mm, might be inserted into tissue with 100 mm to 150 mm of its length, and might be used in soft tissue core biopsies in the neck, the head, the breast, the prostate, and the liver.

[0084] A fine aspiration needle of soft tissue might have an outer diameter between 0.711 mm and 2.108 mm, might be inserted into soft tissue with 100 mm to 150 mm of its length, and might be used for aspiration of soft tissue.

[0085] A brain biopsy needle might have an outer diameter of 2.108 mm, might be inserted into tissue with 150 mm up to 250 mm of its length, and might be used for diagnostic brain biopsies.

[0086] Finally, the device may include a needle electrode having an outer diameter of 2.108 mm and smaller, the electrode might be inserted into tissue up to 250 mm of its length, and might be used for radio frequency ablation for instance of tumors.

[0087] The flow-chart in Fig. 9 illustrates the principle of the steps performed in accordance with an embodiment described herein. It will be understood that the steps described, are major steps, wherein these major steps might be differentiated or divided into several sub-steps. Furthermore, there might be also sub-steps between these major steps. In step S1, a photonic biopsy device is positioned within tissue of a living body. This may be performed under image guidance. Furthermore, the positioning may be controlled by means of the tissue inspection provided by the optical fibers within the biopsy device.

[0088] In step S2, when a target region for a biopsy is reached, an in-vivo tissue inspection is performed to obtain in-vivo information related to a specific tissue.

[0089] In step S3, the inspected tissue is extracted from the living body. The extraction may take place either by removing the biopsy device with the tissue sample sealed in the notch of the device, or by applying vacuum and sucking out the tissue sample through a channel provided in the biopsy device. The extracted tissue sample may then be transferred to a device for ex-vivo tissue inspection.

[0090] It is noted that sucking out the tissue sample and thus leaving the tip of the biopsy device in the target region may provide for the possibility to perform the method again in close vicinity to the former tissue inspection, if necessary. This may be decided immediately after extracting and ex-vivo inspecting the former tissue sample.

[0091] In step S4, an ex-vivo tissue inspection is performed on the previously extracted tissue sample. The step may include any necessary preparation steps like making tissue slices and staining the slices with H&E and/or with specific biomarkers. The tissue slices may also be digitized using a digital pathology system.

[0092] In step S5, the information obtained in-vivo is combined and/or integrated with the information obtained ex-vivo. This can also be molecular diagnostics data (e.g. sequencing or PCR), performed on the tissue biopsy or part of the biopsy.

[0093] In step S6, the tissue sample may be situated in a storage container to save the sample. Together with the tissue, all the obtained information may be stored at the container, for example in an electronic chip, wherein the information may include the in-vivo pathology data, the ex-vivo pathology data, the information representing the location

at which the biopsy has been taken, and the like. In other words, all data received during the complete method, may be stored together with the sample in the storage container.

[0094] While the invention has been illustrated and described in detail in the drawings and foregoing description, such illustration and description are to be considered illustrative or exemplary and not restrictive; the invention is not limited to the disclosed embodiments. Other variations to the disclosed embodiments may be understood and effected by those skilled in the art in practicing the claimed invention, from a study of the drawings, the disclosure, and the appended claims.

[0095] In the claims, the word "comprising" does not exclude other elements or steps, and the indefinite article "a" or "an" does not exclude a plurality. The mere fact that certain measures are recited in mutually different dependent claims does not indicate that a combination of these measures cannot be used to advantage. Any reference signs in the claims should not be construed as limiting the scope.

LIST OF REFERENCE SIGNS:

[0096]

- 10 shaft
- 12 insert
- 13 opening
- 15 distal end
- 20 recess
- 30 bevel
- 35 fiber body
- 40 optical fiber
- 45 channel/opening
- 50 tubular member
- 55 distal edge
- 60 console
- 64 light source
- 66 light detector
- 68 monitor
- 70 suction device
- 80 device for ex-vivo tissue inspection
- 90 storage container
- 100 shaft
- 200 notch
- 500 outer member

Claims

1. A system for obtaining pathological information, including a biopsy device comprising a tubular member (50) having a distal end, a hollow shaft (10), the hollow shaft having a distal end (12), wherein a sidewardly facing notch (20) is formed in the hollow shaft adjacent the distal end of the hollow shaft, wherein the hollow shaft is movably accommodated within the tubular member, and an elongated fiber body (35) including at least one optical fiber (40), the optical fiber having a distal end, wherein the fiber body is accommodated within the hollow shaft, wherein the tubular member (50) is movable between a first position in which the notch (20) is covered by the tubular member, and a second position in which the notch is not covered by the tubular member, and wherein the hollow shaft (10) is movable between a first position in which the distal end of the optical fiber (40) is located at the distal end of the hollow shaft (10) with the elongated fiber body extending through the notch, and a second position in which the device is configured to locate the distal end of the at least one optical fiber proximally to the notch by ejecting the hollow shaft (10) with respect to the tubular member (50) such that the elongated fiber body (35) remains in a fixed position with respect to the distal end of the tubular member (50).
2. The system of claim 1, wherein the fiber body (35) of the biopsy device comprises a bevel (30) at a distal end of the fiber body, with the distal end of the at least one optical fiber (40) located adjacent the bevel of the fiber body, and

wherein the bevel of the fiber body is located adjacent the distal end of the hollow shaft, when the fiber body is in the first position.

- 5 3. The system of claim 1, wherein the at least one optical fiber protrudes beyond the distal end of the fiber body, and wherein an insert (12) is arranged within the hollow shaft of the biopsy device between the distal end (12) of the hollow shaft and the notch (20), wherein the insert includes openings (13) for accommodating the protruding distal end of the at least one optical fiber (40), when the fiber body is in the first position.
- 10 4. The system of any one of claims 1 to 3, wherein the biopsy device further comprises a channel (45) for injecting or extracting a fluid.
- 15 5. The system of any one of claims 1 to 4, wherein the notch (20) is adapted to accommodate a tissue sample to be taken from a tissue.
- 20 6. The system of any one of claims 1 to 5, further comprising a suction device (70) for applying vacuum, wherein the biopsy device further comprises a tissue retraction channel, wherein the suction device is adapted to apply vacuum to the channel (45).
7. The system of any one of claims 1 to 6, further comprising a console (60) including a light source (64), a light detector (66) and a processing unit for processing the signals provided by the light detector, the console being adapted for in-vivo tissue inspection.
- 25 8. The system of any one of claims 1 to 7, further comprising a device (80) adapted for ex-vivo tissue inspection.
9. The system of claim 7 or 8, further comprising a storage container (90) for receiving an extracted tissue sample and for storing pathology information obtained by an in-vivo tissue inspection and/or an ex-vivo tissue inspection.

Patentansprüche

- 30 1. System zum Gewinnen von pathologischen Informationen, enthaltend eine Biopsievorrichtung, umfassend ein rohrförmiges Element (50), das ein distales Ende aufweist, einen hohlen Schaft (10), wobei der hohle Schaft ein distales Ende (12) aufweist, wobei eine seitwärts zeigende Kerbe (20) im hohlen Schaft angrenzend zum distalen Ende des hohlen Schafts gebildet ist, wobei der hohle Schaft beweglich innerhalb des rohrförmigen Elements aufgenommen ist, und
 - 35 einen länglichen Faserkörper (35), der mindestens eine optische Faser (40) enthält, wobei die optische Faser ein distales Ende aufweist, wobei der Faserkörper innerhalb des hohlen Schafts aufgenommen ist, wobei das rohrförmige Element (50) beweglich ist zwischen einer ersten Position, in der die Kerbe (20) vom rohrförmigen Element abgedeckt ist, und einer zweiten Position, in der die Kerbe vom rohrförmigen Element nicht abgedeckt ist, und
 - 40 wobei der hohle Schaft (10) beweglich ist zwischen einer ersten Position, in der das distale Ende der optischen Faser (40) am distalen Ende des hohlen Schafts (10) positioniert ist, während sich der längliche Faserkörper durch die Kerbe erstreckt, und einer zweiten Position, in der die Vorrichtung konfiguriert ist, um durch Auswerfen des hohlen Schafts (10) in Bezug auf das rohrförmige Element (50) das distale Ende der mindestens einen optischen Faser proximal zur Kerbe so zu positionieren, dass der längliche Faserkörper (35) an einer fixen Position in Bezug auf das distale Ende des rohrförmigen Elements (50) verbleibt.
- 45 2. System nach Anspruch 1, wobei der Faserkörper (35) der Biopsievorrichtung am distalen Ende des Faserkörpers eine Abschrägung (30) umfasst, während das distale Ende der mindestens einen optischen Faser (40) angrenzend zur Abschrägung des Faserkörpers positioniert ist, und wobei die Abschrägung des Faserkörpers angrenzend zum distalen Ende des hohlen Schafts positioniert ist, wenn sich der Faserkörper in der ersten Position befindet.
- 50 3. System nach Anspruch 1, wobei die mindestens eine optische Faser über das distale Ende des Faserkörpers hinaus vorsteht, und wobei ein Einsatz (12) innerhalb des hohlen Schafts der Biopsievorrichtung zwischen dem distalen Ende (12) des hohlen Schafts und der Kerbe (20) angeordnet ist, wobei der Einsatz Öffnungen (13) zum Aufnehmen des vorstehenden distalen Endes der mindestens einen optischen Faser (40), wenn sich der Faserkörper in der ersten Position befindet, enthält.

EP 2 914 164 B1

4. System nach einem der Ansprüche 1 bis 3, wobei die Biopsievorrichtung weiter einen Kanal (45) zum Einspritzen oder Extrahieren eines Fluids umfasst.
5. System nach einem der Ansprüche 1 bis 4, wobei die Kerbe (20) angepasst ist, um eine aus einem Gewebe zu entnehmende Gewebeprobe aufzunehmen.
6. System nach einem der Ansprüche 1 bis 5, weiter umfassend eine Saugvorrichtung (70) zum Anwenden von Vakuum, wobei die Biopsievorrichtung weiter einen Geweberückziehkana1 enthält, wobei die Saugvorrichtung angepasst ist, um Vakuum auf den Kanal (45) anzuwenden.
7. System nach einem der Ansprüche 1 bis 6, weiter umfassend eine Konsole (60), die eine Lichtquelle (64), einen Lichtdetektor (66) und eine Verarbeitungseinheit zum Verarbeiten der vom Lichtdetektor bereitgestellten Signale enthält, wobei die Konsole für Gewebeinspektion *in vivo* angepasst ist.
8. System nach einem der Ansprüche 1 bis 7, weiter umfassend eine Vorrichtung (80), die für Gewebeinspektion *ex vivo* angepasst ist.
9. System nach Anspruch 7 oder 8, weiter umfassend einen Speicherbehälter (90) zum Erhalten einer extrahierten Gewebeprobe und zum Speichern von Pathologieinformationen, die mit einer Gewebeinspektion *in vivo* und/oder einer Gewebeinspektion *ex vivo* ermittelt wurden.

Revendications

1. Système pour obtenir des informations pathologiques, incluant un dispositif de biopsie comprenant un élément tubulaire (50) ayant une extrémité distale, un arbre creux (10), l'arbre creux ayant une extrémité distale (12), dans lequel une encoche (20) faisant face latéralement est formée dans l'arbre creux à proximité adjacente de l'extrémité distale de l'arbre creux, dans lequel l'arbre creux est reçu de manière mobile à l'intérieur de l'élément tubulaire, et un corps de fibre allongé (35) incluant au moins une fibre optique (40), la fibre optique ayant une extrémité distale, le corps de fibre étant reçu à l'intérieur de l'arbre creux, dans lequel l'élément tubulaire (50) est mobile entre une première position dans laquelle l'encoche (20) est recouverte par l'élément tubulaire, et une seconde position dans laquelle l'encoche n'est pas recouverte par l'élément tubulaire, et dans lequel l'arbre creux (10) est mobile entre une première position dans laquelle l'extrémité distale de la fibre optique (40) est située au niveau de l'extrémité distale de l'arbre creux (10), le corps de fibre allongé s'étendant à travers l'encoche, et une seconde position dans laquelle le dispositif est configuré pour positionner l'extrémité distale de la au moins une fibre optique de manière proximale à l'encoche en éjectant l'arbre creux (10) par rapport à l'élément tubulaire (50) de sorte que le corps de fibre allongé (35) reste dans une position fixe par rapport à l'extrémité distale de l'élément tubulaire (50).
2. Système selon la revendication 1, dans lequel le corps de fibre (35) du dispositif de biopsie comprend un biseau (30) au niveau d'une extrémité distale du corps de fibre, l'extrémité distale de la au moins une fibre optique (40) étant positionnée à proximité adjacente du biseau du corps de fibre, et dans lequel le biseau du corps de fibre est positionné à proximité adjacente de l'extrémité distale de l'arbre creux, lorsque le corps de fibre est dans la première position.
3. Système selon la revendication 1, dans lequel la au moins une fibre optique fait saillie au-delà de l'extrémité distale du corps de fibre, et dans lequel un insert (12) est disposé à l'intérieur de l'arbre creux du dispositif de biopsie entre l'extrémité distale (12) de l'arbre creux et l'encoche (20), dans lequel l'insert comprend des ouvertures (13) pour recevoir l'extrémité distale en saillie de la au moins une fibre optique (40), lorsque le corps de fibre est dans la première position.
4. Système selon l'une quelconque des revendications 1 à 3, dans lequel le dispositif de biopsie comprend en outre un canal (45) pour injecter ou extraire un fluide.
5. Système selon l'une quelconque des revendications 1 à 4, dans lequel l'encoche (20) est adaptée pour recevoir un

EP 2 914 164 B1

échantillon de tissu à prélever d'un tissu.

- 5
6. Système selon l'une quelconque des revendications 1 à 5, comprenant en outre un dispositif d'aspiration (70) pour appliquer un vide, dans lequel le dispositif de biopsie comprend en outre un canal de rétraction de tissu, dans lequel le dispositif d'aspiration est adapté pour appliquer un vide au canal (45).
- 10
7. Système selon l'une quelconque des revendications 1 à 6, comprenant en outre une console (60) comprenant une source de lumière (64), un détecteur de lumière (66) et une unité de traitement pour traiter les signaux fournis par le détecteur de lumière, la console étant adaptée pour un examen in-vivo de tissu.
- 15
8. Système selon l'une quelconque des revendications 1 à 7, comprenant en outre un dispositif (80) adapté pour un examen ex-vivo de tissu.
- 20
9. Système selon la revendication 7 ou 8, comprenant en outre un conteneur de stockage (90) pour recevoir un échantillon de tissu extrait et pour stocker des informations pathologiques obtenues par un examen in-vivo de tissu et/ou un examen ex-vivo de tissu.
- 25
- 30
- 35
- 40
- 45
- 50
- 55

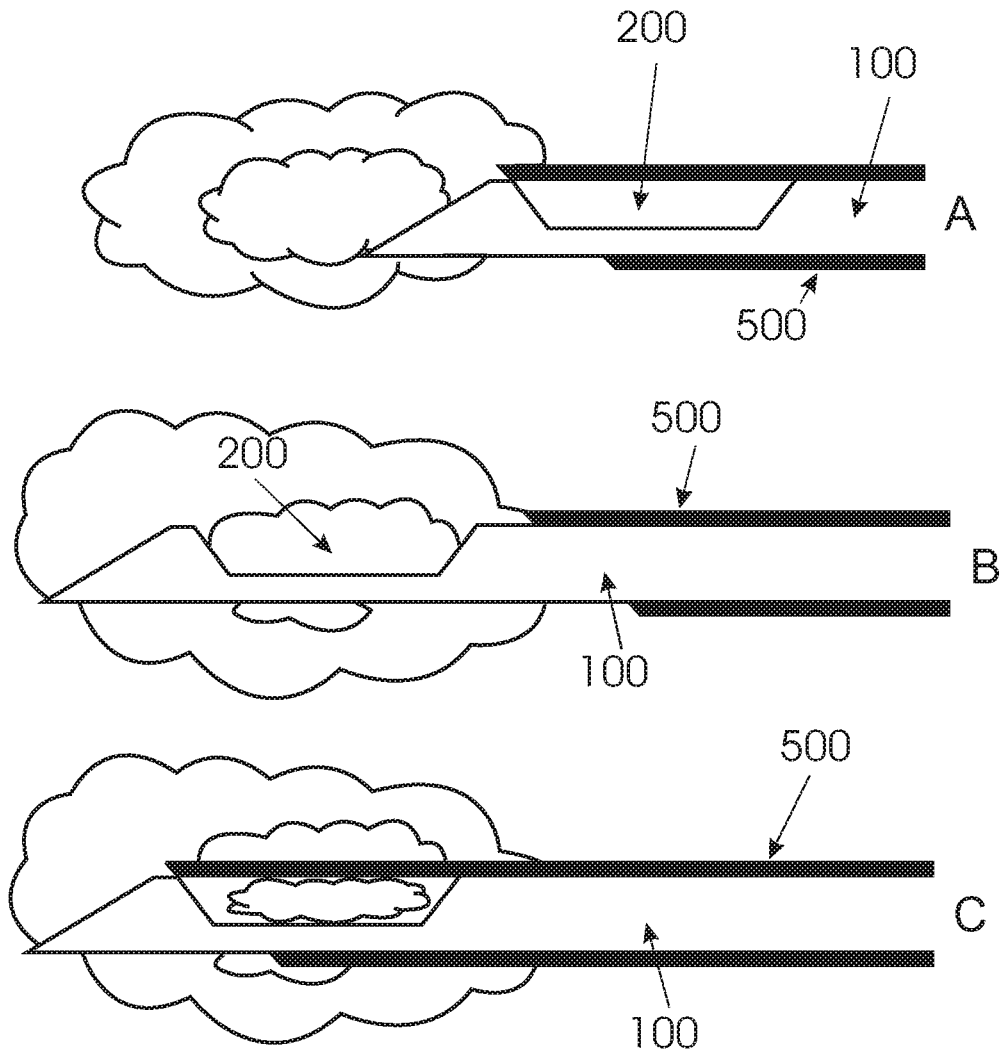

Fig. 1

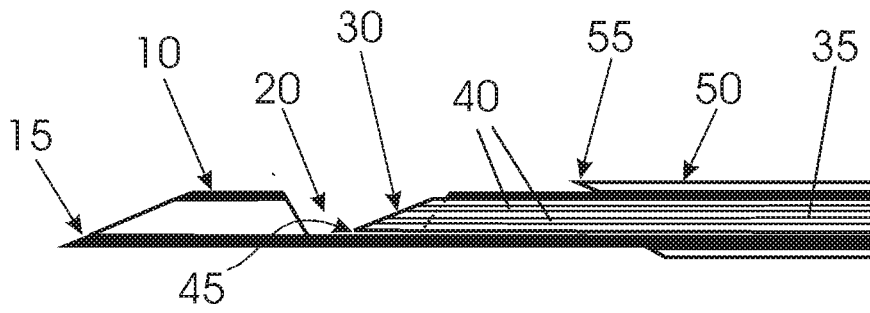

Fig. 2

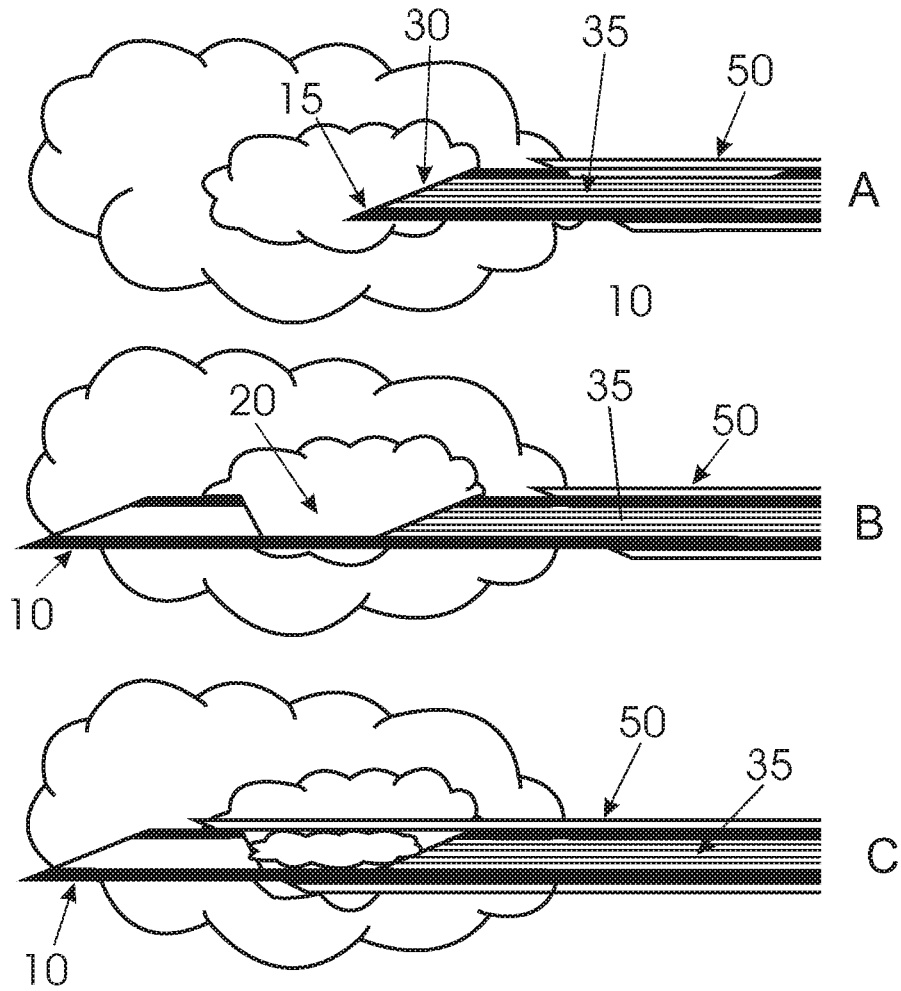

Fig. 3

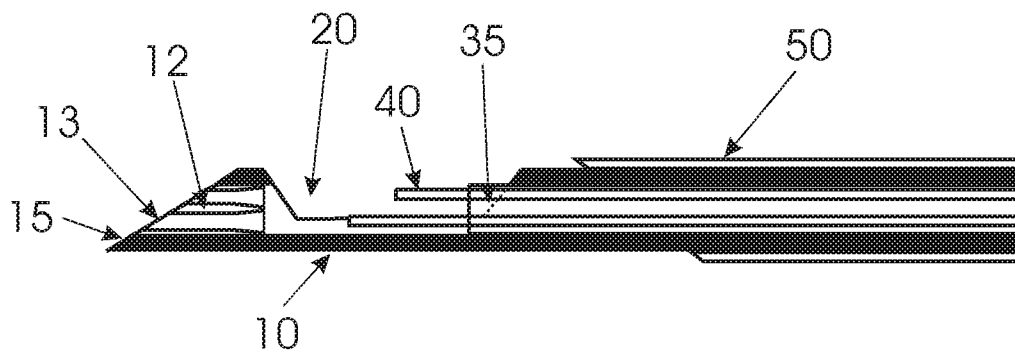

Fig. 4

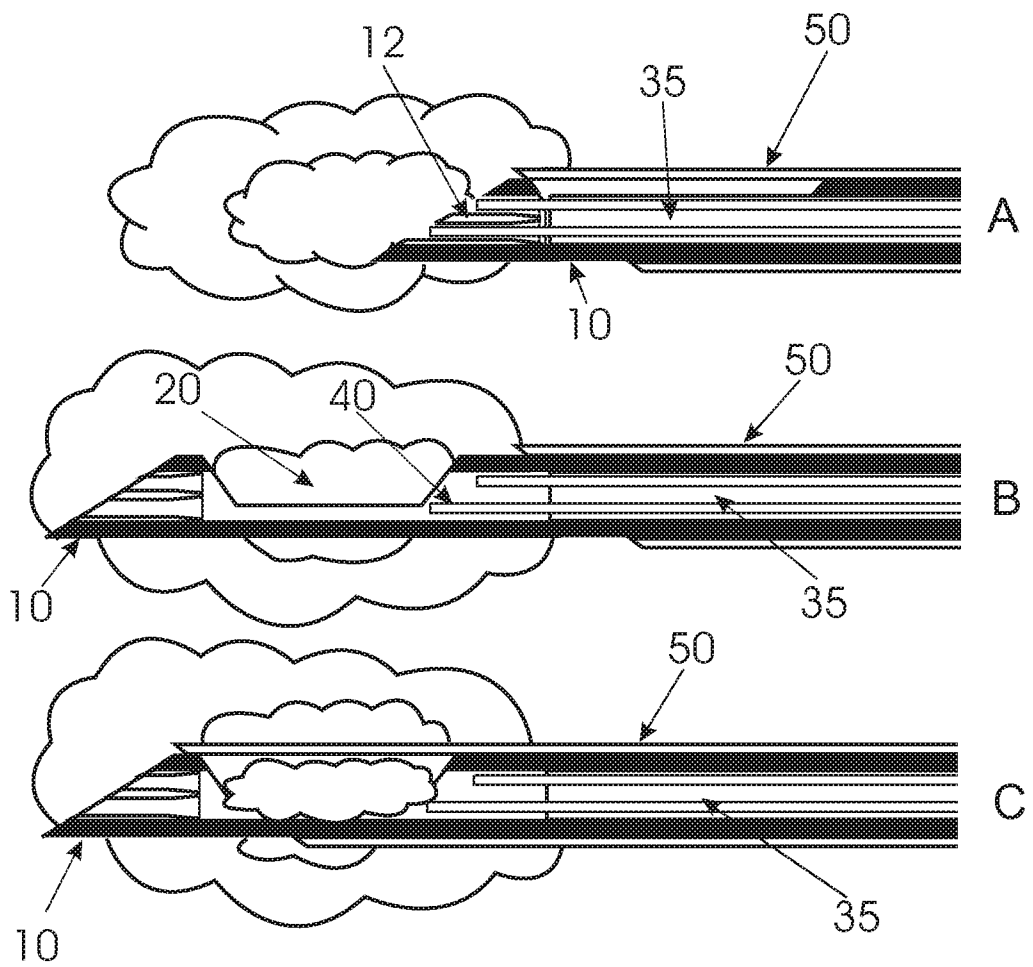

Fig. 5

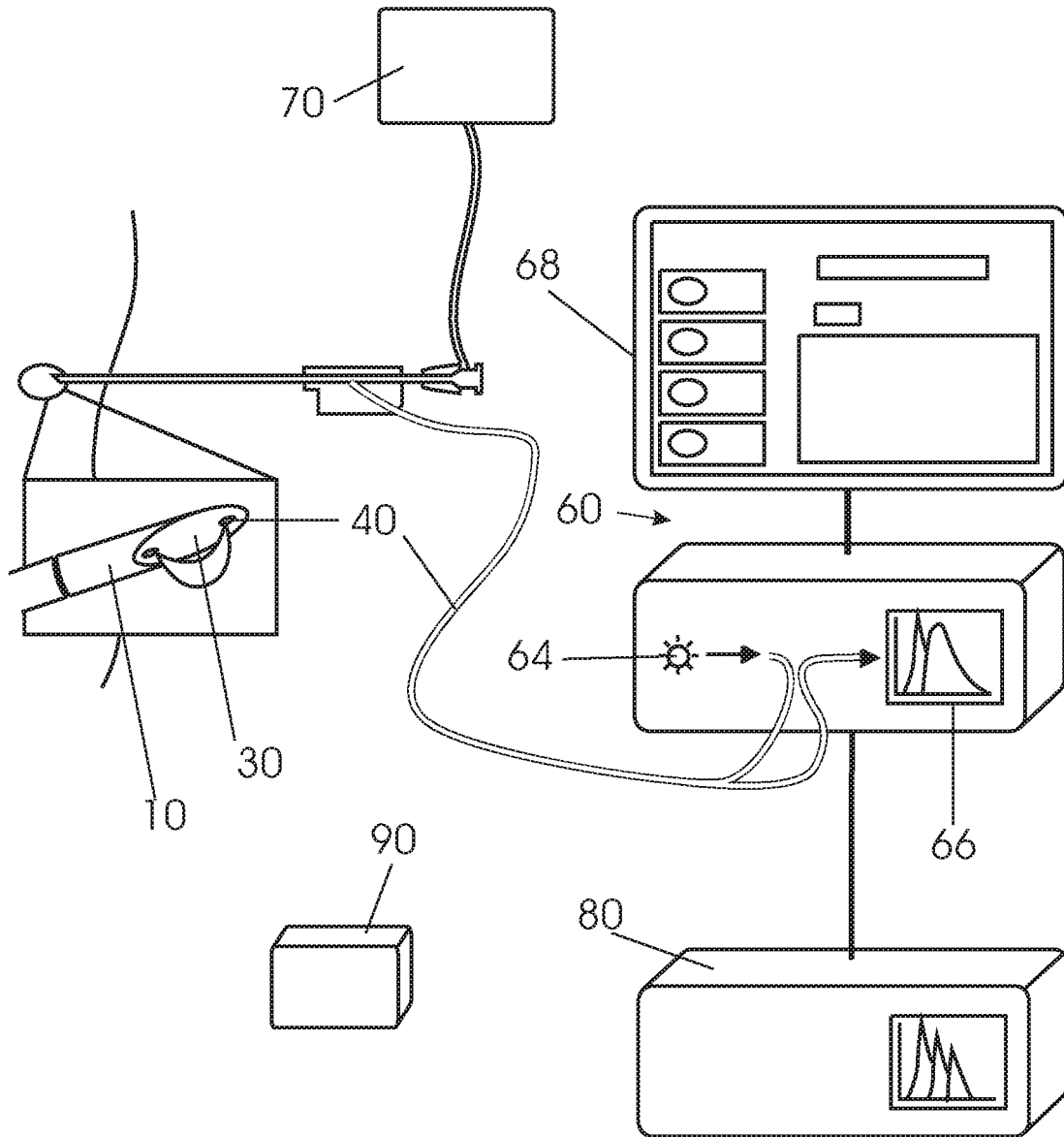

Fig. 6

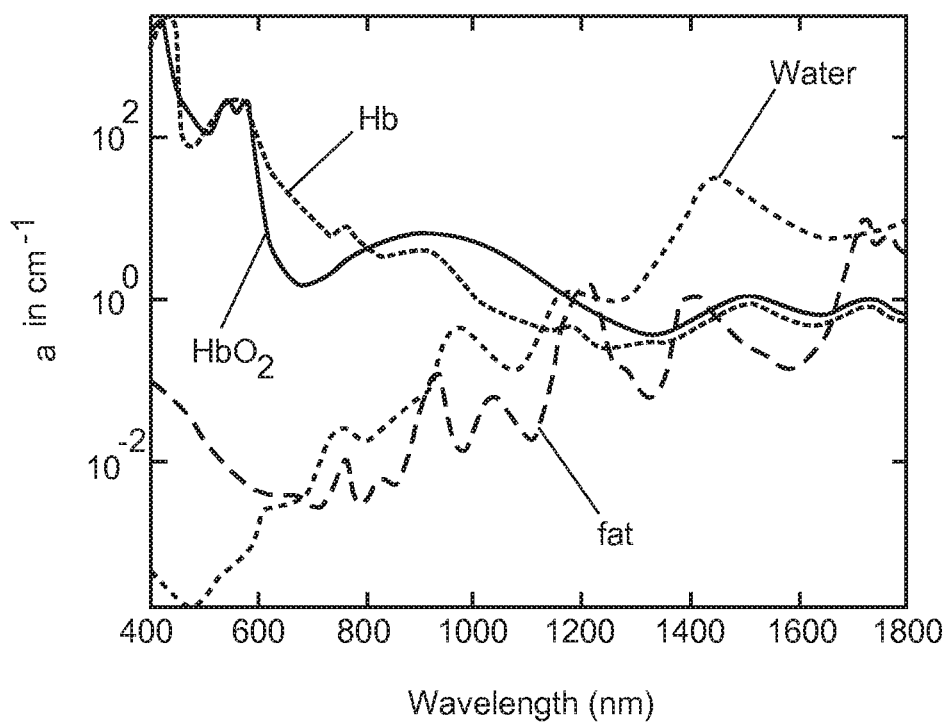

Fig. 7

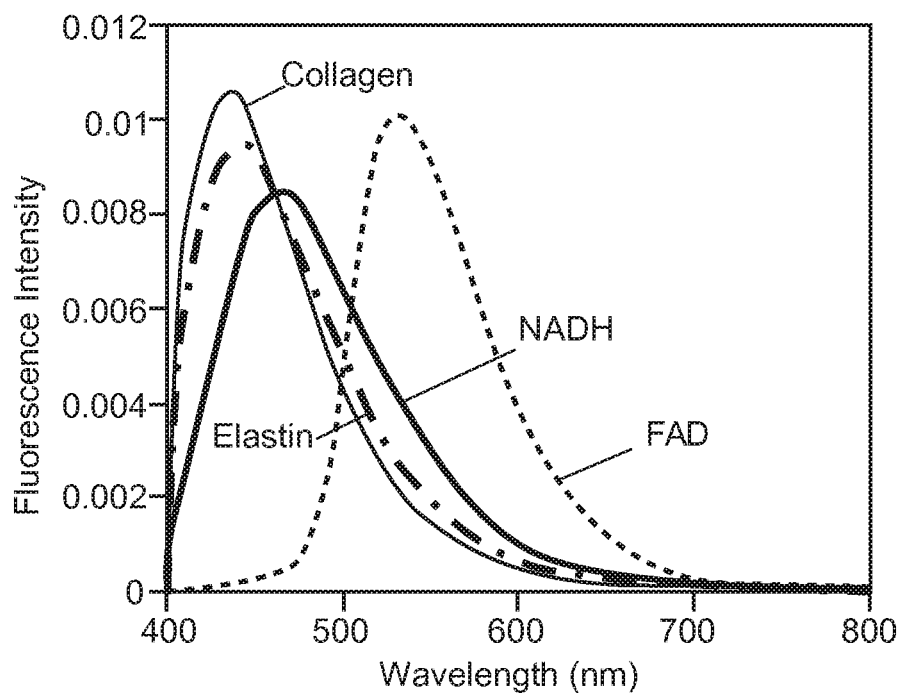

Fig. 8

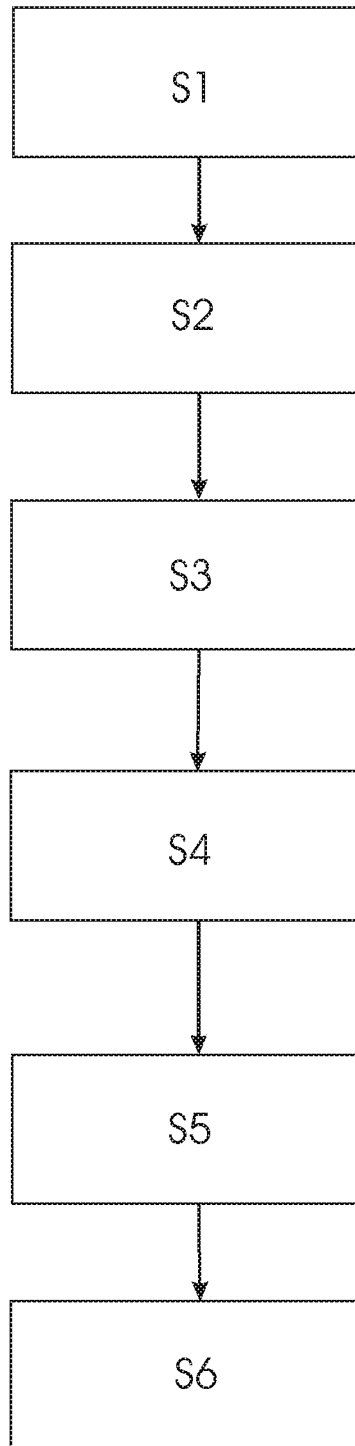

Fig. 9

REFERENCES CITED IN THE DESCRIPTION

This list of references cited by the applicant is for the reader's convenience only. It does not form part of the European patent document. Even though great care has been taken in compiling the references, errors or omissions cannot be excluded and the EPO disclaims all liability in this regard.

Patent documents cited in the description

- US 2005070818 A1 [0005]
- US 2005203419 A1 [0006]
- US 6564087 B1 [0007]
- US 2002128570 A1 [0008]

Non-patent literature cited in the description

- **R. NACHABE ; B.H.W. HENDRIKS ; A.E. DESJARDINS ; M. VAN DER VOORT ; M.B. VAN DER MARK ; H.J.C.M. STERENBORG.** Estimation of lipid and water concentrations in scattering media with diffuse optical spectroscopy from 900 to 1600nm. *J. Biomed. Opt.*, 2010, vol. 15, 037015 [0056] [0069] [0075]
- **T.J.FARREL ; M.S.PATTERSON ; B.C.WILSON.** A diffusion theory model of spatially resolved, steady-state diffuse reflectance for the non-invasive determination of tissue optical properties. *Med.Phys.*, 1992, vol. 19, 879-888 [0068]
- **R.NACHABE ; B.H.W. HENDRIKS ; M. VAN DER VOORT,A.E. ;H.J.C.M. STERENBORG.** Estimation of biological chromophores using diffuse optical spectroscopy: benefit of extending the UV-VIS wavelength range to include 1000 to 1600 nm. *Optics Express*, 2010, vol. 18, 1432-1442 [0069] [0075]
- **ZHANG Q. et al.** Turbidity-free fluorescence spectroscopy of biological tissue. *Opt. Lett.*, 2000, vol. 25 (19), 1451-1453 [0079]

专利名称(译)	具有光子活检装置的系统用于获得病理信息		
公开(公告)号	EP2914164A1	公开(公告)日	2015-09-09
申请号	EP2013821163	申请日	2013-10-28
[标]申请(专利权)人(译)	皇家飞利浦电子股份有限公司		
申请(专利权)人(译)	皇家飞利浦N.V. PHILIPS GMBH		
当前申请(专利权)人(译)	皇家飞利浦N.V. PHILIPS GMBH		
[标]发明人	BIERHOFF WALTHERUS CORNELIS JOZEF REICH CHRISTIAN VAN DER MARK MARTINUS BERNARDUS HENDRIKS BERNARDUS HENDRIKUS WILHELMUS VAN DE STOLPE ANJA VOSS STEPHAN WINKEL AXEL VAN DER VOORT MARJOLEIN PULLY VISHNU VARDHAN LUCASSEN GERHARDUS WILHELMUS VAN DEN BERG DAMS SUSANNE DORIEN SPLIETHOFF JARICH WILLEM		
发明人	BIERHOFF, WALTHERUS CORNELIS JOZEF REICH, CHRISTIAN VAN DER MARK, MARTINUS BERNARDUS HENDRIKS, BERNARDUS HENDRIKUS WILHELMUS VAN DE STOLPE, ANJA VOSS, STEPHAN WINKEL, AXEL VAN DER VOORT, MARJOLEIN PULLY, VISHNU VARDHAN LUCASSEN, GERHARDUS WILHELMUS VAN DEN BERG-DAMS, SUSANNE DORIEN SPLIETHOFF, JARICH WILLEM		
IPC分类号	A61B5/00 A61B10/02		
CPC分类号	A61B5/0071 A61B5/0075 A61B5/0084 A61B5/14503 A61B5/14546 A61B5/14552 A61B5/14556 A61B5/1459 A61B5/6848 A61B10/0275 A61B10/0096 A61B10/04 A61B2010/045 A61B1/00165 A61B1/015 A61B5/0073 A61B2560/0475 A61B2560/0487		
代理机构(译)	STEFFEN , THOMAS		
优先权	61/721541 2012-11-02 US		
其他公开文献	EP2914164B1		
外部链接	Espacenet		
摘要(译)			

活检装置包括管状构件，空心轴和具有至少一根光纤的细长纤维体。中空轴在其远端部分具有侧向（侧向）的凹口。管状构件可在第一位置和第二位置之间相对于轴移动，在第一位置处，凹口被管状构件覆盖，在第二位置中，凹口未被管状构件覆盖。轴可在第一位置和第二位置之间移动，在该第一位置中，光纤的远端位于轴的远端，其中细长纤维体延伸穿过凹口，在第二位置中，至少一个的远端 光纤位于槽口的近端。