



(11) **EP 2 804 524 B1**

(12) **EUROPEAN PATENT SPECIFICATION**

(45) Date of publication and mention of the grant of the patent:
24.04.2019 Bulletin 2019/17

(21) Application number: **13738761.9**

(22) Date of filing: **17.01.2013**

(51) Int Cl.:
A61B 5/00 (2006.01) A61B 5/145 (2006.01)

(86) International application number:
PCT/IB2013/050442

(87) International publication number:
WO 2013/108209 (25.07.2013 Gazette 2013/30)

(54) **VESSEL IMAGING SYSTEM AND METHOD**

GEFÄSSBILDGEBUNGSSYSTEM UND VERFAHREN

SYSTÈME ET MÉTHODE D'IMAGERIE DE VAISSEAU

(84) Designated Contracting States:
AL AT BE BG CH CY CZ DE DK EE ES FI FR GB GR HR HU IE IS IT LI LT LU LV MC MK MT NL NO PL PT RO RS SE SI SK SM TR

(30) Priority: **19.01.2012 US 201261588631 P**

(43) Date of publication of application:
26.11.2014 Bulletin 2014/48

(73) Proprietor: **Technion Research & Development Foundation Ltd.**
3200004 Haifa (IL)

(72) Inventors:
• **YELIN, Dvir**
3478904 Haifa (IL)
• **GOLAN, Lior**
3298348 Haifa (IL)

(74) Representative: **Denemeyer & Associates S.A.**
Postfach 70 04 25
81304 München (DE)

(56) References cited:
WO-A1-2004/044562 WO-A1-2009/037432
WO-A2-2008/005282 US-A1- 2006 134 002
US-A1- 2008 021 329 US-A1- 2010 045 778
US-A1- 2010 045 778 US-A1- 2011 044 910
US-B2- 7 904 138

- **LIOR GOLAN ET AL: "Noninvasive imaging of flowing blood cells using label-free spectrally encoded flow cytometry", BIOMEDICAL OPTICS EXPRESS, vol. 3, no. 6, 1 June 2012 (2012-06-01), page 1455, XP055202682, ISSN: 2156-7085, DOI: 10.1364/BOE.3.001455**

Note: Within nine months of the publication of the mention of the grant of the European patent in the European Patent Bulletin, any person may give notice to the European Patent Office of opposition to that patent, in accordance with the Implementing Regulations. Notice of opposition shall not be deemed to have been filed until the opposition fee has been paid. (Art. 99(1) European Patent Convention).

EP 2 804 524 B1

Description

FIELD AND BACKGROUND OF THE INVENTION

[0001] The present invention relates to a method and a probe for locating a blood vessel and imaging particles flowing therethrough. The invention is defined by the independent claims. Preferred embodiments are defined by the dependent claims.

[0002] Endoscopic confocal microscopy devices are extensively used in minimally invasive medical diagnosis to look below tissue surfaces and for intervention purposes. Confocal microscopy is a technique generally used to acquire an image of a specimen and is based on focusing illuminating light from a point source to a point on the specimen, and focusing emitted light (responsive to the illuminating light) from the illuminated point on the specimen onto a small pinhole in an opaque screen. As only the emitted light from the illuminated point is focused onto the hole, the emitted light passes through the pinhole while all other light not emitted by the point is substantially blocked out. A detector on the other side of the screen detects the amount of emitted light passing through the pinhole and quantifies the amount for image reproduction purposes. As only one point in the specimen is illuminated at a time, two-dimensional (2D) or three-dimensional (3D) imaging generally is done by scanning over a regular raster (a rectangular pattern of parallel scanning lines) in the specimen.

[0003] A technique generally used to integrate confocal microscopy inside probes used in medical and scientific applications such as, for example, endoscopic probes and catheters, is spectrally encoded confocal microscopy (SECM). In SECM, the specimen is generally scanned line by line, with illuminating light at a different wavelength hitting each point along a line (each point on a line is "encoded" by a different wavelength). Emitted light from each point (each point emitting light at a different wavelength) is detected by a detector and, spatial information of the specimen along the line may be decoded by measuring the detected wavelengths. A 2D image may be reproduced by relatively slowly scanning the encoded lines mechanically within the probe.

[0004] An alternative technique to SECM is spectrally encoded endoscopy (SEE). SEE described in "Volumetric sub-surface imaging using spectrally encoded endoscopy", by D. Yelin et al, Optics Express 1750/ Vol. 16, No. 3/ 4 February 2008; as follows: "Spectrally encoded endoscopy (SEE) [7] is a recently developed technique that utilizes wavelength to encode transverse image information. The SEE probe, comprising a single optical fiber, a diffraction grating, and a low NA lens, focuses spectrally dispersed light onto the sample. In turn, each point along this line is illuminated by a distinct spectral band. Each line of the image is acquired by measuring the spectrum of light reflected from the sample and returned back through the SEE probe using a high-speed spectrometer that resides outside the body. The second

dimension of the image is obtained by moving the fiber at slow rates (e.g. 30 Hz). Without the need for rapid transverse scanning at the distal end of the endoscope, SEE allows video rate imaging to be performed through a miniature (i.e. 350 μm diameter) endoscopic device [13]. When the SEE probe is placed in the sample arm of an interferometer, it additionally can achieve three-dimensional topological, surface imaging in real-time, by use of time [14] and spectral [13, 15] domain low coherence interferometry."

[0005] Use of SECM for spectrally encoded imaging of flowing blood cells is further described in "Flow cytometry using spectrally encoded confocal microscopy", by D. Yelin and L. Golan, Optics, Volume 35, Issue 13, 2218-2220 (2010), which relates to "Flow cytometry techniques often rely on detecting fluorescence from single cells flowing through the cross section of a laser beam, providing invaluable information on vast numbers of cells. Such techniques, however, are often limited in their ability to resolve clusters of cells or parallel cell flow through large vessels. We present a confocal imaging technique that images unstained cells flowing in parallel through a wide channel, using spectrally encoded reflectance confocal microscopy that does not require mechanical scanning. Images of red blood cells from our system are compared to conventional transmission microscopy, and imaging of flowing red blood cells *in vitro* is experimentally demonstrated."

[0006] It is known that green light is more susceptible to absorption by blood compared to the other colors in the light spectrum. This makes green light an important component for detecting blood vessels in the body. U.S. Publication No. 2008/0045817 to Van Beek et al describes, "Provided is a method and an apparatus for detection of objects below the surface of diffuse scattering media, in particular blood capillaries in organs such as the skin of human beings, using Orthogonal Polarized Spectral Imaging (OPSI), according to the invention comprising the steps of: imaging the object in question at least two different angles so as to obtain a shift of position in the imaging plane; and subsequently comparing relative shifts of objects in the two images so as to obtain coordinates of the imaged objects with respect to the organ surface."

[0007] Further background art includes U.S. Patent Publication No. 2011/0044910 to Lin, which relates to "*in vivo* flow cytometry by using blood vessels as flow chambers" using fluorescence imaging (optionally of intrinsic fluorophores) and optionally in conjunction with wide-field illumination for visualization of vasculature. U.S. Patent Publication No. 2006/0134002, also to Lin, relates to "*in vivo* flow cytometry" using fluorescence imaging of labeled cells, optionally in conjunction with wide field illumination for identification of vasculature.

SUMMARY OF THE INVENTION

[0008] The invention is defined by the independent

claims. Preferred embodiments are defined by the dependent claims.

[0009] Implementation of the method and/or system of embodiments of the invention can involve performing or completing selected tasks manually, automatically, or a combination thereof. Moreover, according to actual instrumentation and equipment of embodiments of the method and/or system of the invention, several selected tasks could be implemented by hardware, by software or by firmware or by a combination thereof using an operating system.

[0010] For example, hardware for performing selected tasks according to embodiments of the invention could be implemented as a chip or a circuit. As software, selected tasks according to embodiments of the invention could be implemented as a plurality of software instructions being executed by a computer using any suitable operating system. In an exemplary embodiment of the invention, one or more tasks according to exemplary embodiments of method and/or system as described herein are performed by a data processor, such as a computing platform for executing a plurality of instructions. Optionally, the data processor includes a volatile memory for storing instructions and/or data and/or a non-volatile storage, for example, a magnetic hard-disk and/or removable media, for storing instructions and/or data. Optionally, a network connection is provided as well. A display and/or a user input device such as a keyboard or mouse are optionally provided as well.

BRIEF DESCRIPTION OF THE DRAWINGS

[0011] Some embodiments of the invention are herein described, by way of example only, with reference to the accompanying drawings and images. With specific reference now to the drawings and images in detail, it is stressed that the particulars shown are by way of example and for purposes of illustrative discussion of embodiments of the invention.

FIG. 1 schematically illustrates a functional block diagram of an exemplary system for imaging a vessel;
 FIG. 2 schematically illustrates a functional block diagram of an exemplary system for imaging a vessel using a broadband light source;
 FIG. 3 schematically illustrates a functional block diagram of an exemplary system for imaging a vessel using a broadband light source and low coherence interferometry;
 FIG. 4 schematically illustrates a functional block diagram of an exemplary system for imaging a vessel using a wavelength-swept light source;
 FIG. 5 schematically illustrates a functional block diagram of an exemplary system for imaging a vessel using a wavelength-swept light source, and single mode and multi-mode optical fibers including a beam splitter;
 FIG. 6 schematically illustrates a functional block di-

agram of an exemplary system for imaging a vessel using a wavelength-swept light source and single mode and multi-mode optical fibers;

FIG. 7A schematically illustrates an exemplary single-event histogram from a cytometer, as known in the art;

FIG. 7B schematically illustrates an exemplary cross-sectional image acquired by any exemplary system shown in FIGs. 1-6;

FIG. 8A illustrates a flow chart of a method for acquiring an image of a particle in a vessel, in accordance with an embodiment of the present invention; FIG. 8B schematically illustrates a functional block diagram of an exemplary system for imaging a vessel using a wavelength-swept light source and low coherence interferometry;

FIG. 9 schematically illustrates an imaging probe used in an imaging system for locating a vessel;

FIG. 10 schematically illustrates an imaging probe used in an imaging system for locating a vessel;

FIG. 11 schematically illustrates an imaging probe used in an imaging system for locating a vessel;

FIG. 12 schematically illustrates an imaging probe used in an imaging system for locating a vessel;

FIG. 13 schematically illustrates an imaging probe used in an imaging system for locating a vessel;

FIG. 14 schematically illustrates an imaging probe used in an imaging system for locating a vessel;

FIG. 15 illustrates a flow chart of an exemplary method for locating a vessel, in accordance with an embodiment of the present invention;

FIG. 16 schematically illustrates an experimental setup of a system for locating a vessel, according to some embodiments of the invention;

FIG. 17A illustrates *In vitro* imaging of flowing blood cells, according to some exemplary embodiments of the invention;

FIG. 17B illustrates *In vitro* imaging of flowing blood cells, according to some exemplary embodiments of the invention;

FIG. 17C illustrates *In vitro* imaging of flowing blood cells, according to some exemplary embodiments of the invention;

FIG. 17D illustrates *In vitro* imaging of flowing blood cells, according to some exemplary embodiments of the invention;

FIG. 18A illustrates *In vivo* noninvasive imaging of blood flow in a single vessel, according to some exemplary embodiments of the invention;

FIG. 18B illustrates *In vivo* noninvasive imaging of blood flow in a single vessel, according to some exemplary embodiments of the invention;

FIG. 18C illustrates *In vivo* noninvasive imaging of blood flow in a single vessel, according to some exemplary embodiments of the invention;

FIG. 18D illustrates *In vivo* noninvasive imaging of blood flow in a single vessel, according to some exemplary embodiments of the invention;

FIG. 19A illustrates *In vivo* imaging in micro vessels, according to some exemplary embodiments of the invention;

FIG. 19B illustrates *In vivo* imaging in micro vessels, according to some exemplary embodiments of the invention;

FIG. 19C illustrates *In vivo* imaging in micro vessels, according to some exemplary embodiments of the invention;

FIG. 19D illustrates *In vivo* imaging in micro vessels, according to some exemplary embodiments of the invention;

FIG. 20A illustrates *In vivo* imaging of white blood cells, WBCs, according to some exemplary embodiments of the invention;

FIG. 20B illustrates *In vivo* imaging of white blood cells, WBCs, according to some exemplary embodiments of the invention;

FIG. 20C illustrates *In vivo* imaging of white blood cells, WBCs, according to some exemplary embodiments of the invention;

FIG. 21A illustrates *In vivo* imaging of white blood cells, WBCs, according to some exemplary embodiments of the invention;

FIG. 21B illustrates *In vivo* imaging of white blood cells, WBCs, according to some exemplary embodiments of the invention;

FIG. 21C illustrates *In vivo* imaging of white blood cells, WBCs, according to some exemplary embodiments of the invention;

FIG. 22 schematically illustrates an imaging probe used in an imaging system for locating a vessel, according to an exemplary embodiment of the invention.

DESCRIPTION OF SPECIFIC EMBODIMENTS OF THE INVENTION

[0012] The present invention relates to a method and a probe for locating a blood vessel and imaging particles flowing therethrough. The invention is defined by the independent claims. Preferred embodiments are defined by the dependent claims.

[0013] The present relates to the method of particle imaging shown in U.S. Application No. 12/461,558 filed on 19 August 2009 and published as U.S. Patent Application Publication No. 2010/0045778 A1 with publication date 25 February 2010. The present invention can also be used with other vessel sensing techniques that sample data about a vessel and/or what is happening in it or near it. The present invention, in some embodiments thereof, may also be used with other vessel sensing techniques and/or to guide the insertion of a biopsy/blood extraction needle. The present invention, in some embodiments thereof, may also be used with other vessel sensing techniques that look at blood analytes.

[0014] An aspect of the present invention relates to a method and system for non-invasively locating vessels

under a tissue surface by illuminating at least a portion of the vessel using a background light which is more highly absorbed by particles in the vessel relative to the vessel itself, and by detecting a backscattered light from the illuminated vessel. By applying the background light, a contrast background is created by the particles' relatively high absorption of the background light. An image of the backscatter light from the background light may then be processed for determining the location of the vessel. In some embodiments, the vessel is illuminated from a position external to the vessel and may be within a search area which may extend to a substantial depth under the tissue surface. This depth may extend up to 100 μm , or even 200 μm , or more. In some embodiments, a field-of-view of the search area may include a few capillaries, for example, 1, 3, 5, 7, 10, 20, 30, 50 capillaries, or intermediate numbers. In some embodiments, the vessel is within a target area which includes a small portion of the field-of-view of the search area. In an exemplary embodiment of the invention, the target area is used for further sensing and/or treatment. In an exemplary embodiment of the invention, the target area is less than 20%, 10%, 5% or intermediate percentages of the field of view. Optionally or alternatively, the field of view is sized, for example, between 1 and 5 diameters of a blood vessel, in diameter. Optionally or alternatively, the field of view is sized, for example, so that the probability of finding a vessel within it is 50% or 10%, or 5%, or an intermediate probability. Optionally or alternatively, said vessel is an artery or vein of at least 20 μm , 40 μm , 80 μm or intermediate widths. Optionally, only the vessel is in this field-of-view. Optionally, the single vessel is a single capillary. In some embodiments, arriving at the target area may include varying a wavelength of the illumination and/or mechanical intervention. In some embodiments, the background light may cover a square of up to 350 μm by 350 μm . Additionally or alternatively, the background light may cover a square of up to 3 mm by 3 mm. In some embodiments, the vessel can be skin, or a surface of a lumen, for example such as may be found in the nasal cavity, a blood vessel, the GI tract, among other body sections.

[0015] In the embodiments of the invention, the background light is a wide-field light. Additionally or alternatively, the background light is a green light. In some exemplary embodiments, normal blood green light (520 nm wavelength) absorption will range from 6% for a 5 μm diameter vessel to approx. 60% for a 75 μm diameter vessel. Alternatively, the background light is a red light.

[0016] The background illumination is transmitted together with the spectrally dispersed illuminating light. The illuminating light, which may be a broadband light or a wavelength-swept light, is spectrally dispersed along an axis of the portion of the vessel. Optionally, spectrally dispersing the illuminating light is part of using techniques known in the art such as SEE (spectral encoded endoscopy) and/or SECM (spectrally encoded conformal microscopy). These techniques may be used for viewing the particles inside the vessel for flow cytometry purposes.

es Transmitting the background light together with the illuminating light allows for locating the vessel and for viewing its particles. The backscattered light from the illumination is detected and processed for generating an image of the portion of the vessel and/or the particles in the vessel. The backscattered light from the background is detected and processed for generating an image. Optionally, only the data for producing the image is generated but not the image.

[0017] In some exemplary embodiments the reproduced image is a two dimensional (2D) image of the portion of the vessel, and may include a cross-section of the portion of the vessel. Optionally, the portion of the vessel may be automatically indicated on it and/or the indication used for processing, or a user does the indicating on the green image. The 2D image may include a cross-section of one or more particles which would be shown as being of a darker or otherwise distinguishable shade compared to other vessel components. A degree of shade intensity may vary between particles or within a particle itself depending on factors such as, for example; the type of particle (red blood cell, white blood cell, leukocytes, granulocytes, etc); the particle's position in the illuminated portion of the vessel; the particle's orientation relative to the direction of illumination and/or direction of flow; particle's size and geometry; among other factors. Additionally or alternatively, a three-dimensional (3D) image may be generated, or a portion thereof.

[0018] In some exemplary embodiments, the method and system offer potential advantages over the art as important blood parameters may be non-invasively determined. Some examples of these parameters include hematocrit, and mean corpuscular volume (MCV). The method and system may also be used for establishing new clinical indices derived from the cells' morphology and dynamics within their natural physiological environment. Additionally, the method and system may be used for continuous tracking of hematocrit levels for intra- and post-surgical monitoring of patients for detecting sudden changes in the circulation caused by internal bleeding. Additionally, the method and system may be used for online monitoring of WBC concentration, which may be applied in critical care medicine to detect a rapidly developing inflammatory process. The method and system may also be used for visualizing cellular deformation, aggregation, margination and adhesion, previously studied mainly in animals and which have shown correlation to various pathological states [G. W. Schmid-Schonbein, S. Usami, R. Skalak, and S. Chien, "The interaction of leukocytes and erythrocytes in capillary and postcapillary vessels," *Microvascular Research* 19, 45-70 (1980); J. J. Bishop, P. R. Nance, A. S. Popel, M. Intaglietta, and P. C. Johnson, "Effect of erythrocyte aggregation on velocity profiles in venules," *Am J Physiol Heart Circ Physiol* 280, H222-236 (2001)]. The method and system may also be used for assessing patients with hemoglobinopathies such as sickle cell anemia and beta thalassemia, and for providing information on the percentage of sickled

and thalassemic cells, respectively. This method may also be used to assess the level of neutrophil-platelet interactions by measuring the degree of aggregation of WBC [K. Konstantopoulos, S. Neelamegham, A. R. Burns, E. Hentzen, G. S. Kansas, K. R. Snapp, E. L. Berg, J. D. Heliums, C. W. Smith, L. V. McIntire, and S. I. Simon, "Venous Levels of Shear Support Neutrophil-Platelet Adhesion and Neutrophil Aggregation in Blood via P-Selectin and β 2-Integrin," *Circulation* 98, 873-882 (1998)]. This method may also be used to screen large populations for anemia and for hematologic malignancies such as leukemia and lymphoma.

[0019] In some exemplary embodiments, the method and system may be used in performing *in vivo* spectrally encoded flow cytometry (SEFC) wherein a plurality of particles in a relatively deep vessel may be substantially counted and optionally examined based on the acquired image. The term "*in vivo*" as used herein in this disclosure, refers to inside a body, for example the body of a patient. Optionally, performing of SEFC may be made *ex vivo*, The terms "*ex vivo*", and "*in vitro*" as used herein in this disclosure, refers to outside of the body, for example, as in vessels and/or organs externally connected to the body (optionally artificial), as in cultures, as in samples used in hydrodynamic-based flow cytometry, as in blood of a patient undergoing extracorporeal therapy such as hemodialysis or apheresis, and/or as in blood samples extracted from the body. The system may determine a number of particles of different types in the vessel, including in a single capillary, and optionally, their location, speed of flow, size, length, shape, orientation, color, or brightness, or any combination thereof. These particles may include, but not be limited to, red blood cells, white blood cells, platelets, blood cell aggregates, parasites, circulating tumor cells, blood clots, gas bubbles, virus, amoeba, germ cells, bacteria, toxins, medicines, stained beads, nano-particles, DNA, RNA, among other microscopic particles adapted to relatively absorb the background light compared to surround components. The term "number" refers to a discrete quantity, and may optionally be a statistic or a relative number.

[0020] In an exemplary embodiment of the present invention, the system comprises a light source for generating the background light; an imaging probe for illuminating the portion of the vessel and for capturing the backscattered light from the illuminated vessel; a detection unit for detecting the backscattered light; a processing unit for reproducing the image of the illuminated portion of the vessel; and a display for displaying the 2D cross-sectional image of the illuminated vessel. Additionally or alternatively, the display displays the 3D image or a portion thereof. The processing unit additionally performs all image and data analysis, including determination of average flow velocity of the particles in the vessel and concentration of particles in the vessel. In some embodiments, the system includes a light source for generating the illuminating light. Optionally, the images displayed include the particles or portions thereof.

[0021] In some exemplary embodiments, the imaging probe is of a relatively small size. Optionally, the imaging probe is adapted to be held in a single hand by a user. In one embodiment, the probe is 11 cm by 5.5 cm by 2.5 cm. In another embodiment, the probe is 6 cm by 4 cm by 1 cm. In an endoscopic example, the probe may have a diameter of, for example, less than 2 cm, 1 cm, 0.8 cm or intermediate diameters. Optionally, the imaging probe does not include any moving mechanical parts. Alternatively, moving mechanical parts are restricted to those required for focusing, for example, by mechanically moving a focusing lens on the cap on the probe. Alternatively, mechanically moving parts are used to scan the tissue for a capillary. Focusing may be performed by pressing the probe against the tissue. In some embodiments, the imaging probe may be an endoscopic probe. Alternatively, imaging probe may be a catheter scope.

[0022] In some exemplary embodiments, the background light source is housed in the imaging probe. Optionally, the background light source includes a LED. Optionally, the LED is operated by a battery. Additionally or alternatively, the probe houses the detection unit, which may include a CMOS camera, a CCD camera, or any other image acquisition means known in the art and suitable for acquiring an image of the backscattered light against the contrast background. Optionally, the CCD transmits the acquired image to the processing unit wirelessly. Additionally or alternatively, the image probe houses the processing unit. Optionally, the processing unit transmits the acquired image to the display wirelessly.

[0023] In some exemplary embodiments, the imaging probe is connected to the illuminating light through a single-mode optical fiber. Optionally, the connection of the imaging probe to the background light source is through a multi-mode optical fiber. In some embodiments, the connection of the imaging probe to the detection unit is through a multi-mode optical fiber.

[0024] In some exemplary embodiments, the imaging probe includes a fixation mechanism for minimizing relative motion between the imaging probe and the tissue without user control, thereby permitting longer imaging periods. In some embodiments, the fixation mechanism includes a low pressure vacuum suction for fixing the tissue in place. Alternatively, the fixation mechanism includes an adhesive which temporarily attaches the probe to the tissue.

[0025] In some embodiments of the present invention, the illumination light is coupled to a fiber coupler on the imaging probe where it is also collimated, diffracted and focused onto a transverse spectral line on the portion of the vessel. Backscattered light that is scattered back from the transverse spectral line is collected by an objective lens in the imaging probe, where it is coupled back into the fiber, and then measured by a fast spectrometer. This optical configuration permits a single-shot line imaging of the particles flowing across the transverse spectral line, and allows fast confocal imaging across the vessel

without any scanning mechanism.

[0026] In some embodiments of the present invention, low coherence interferometry is used to achieve depth information. By adding the reference arm, emitted light interferes with a reference light, which allows determining an axial location (for example along a z-axis or an x-axis, a y-axis, or any non-principal axis) of the illuminated particle, as well as increase sensitivity and speed of the system. Using the coherence gate allows using a lower numerical-aperture lens which simplifies the system and provides larger depth range.

[0027] An aspect of some embodiments of the present invention relates to an imaging probe which is configured to be a beam combiner for providing light from different sources a common aperture for illumination, and a beam splitter for providing backscatter light destined to different receivers the common aperture for reception. The imaging probe includes a beam combiner/splitter connected on one side through a common optical channel to the aperture, and on the other side to a plurality of optical channels which lead to light sources and/or light receivers. All light entering and leaving through the aperture pass through the common optical channel. In some embodiments of the present invention, the plurality of optical channels includes separate illumination and backscatter channels. In some embodiments, the combiner/splitter is a same optical component. Alternatively, they are separate components (combiner and splitter). A single-mode fiber is optionally used for the illuminating light and background light while a multimode fiber with larger core is optionally used for the background light and to collect the backscattered light after passing through the combiner/splitter. This technique potentially improves one or more of signal efficiency, depth of field, speckle noise and reduces undesired back reflections.

[0028] Figures 1-8 relate to a system and method for performing flow cytometry including a technique of creating a transverse spectrally encoded line across a vessel and imaging a reflectance of particles as they flow across the line. A 2D image of the particles is then formed, one axis is encoded by the wavelength of the reflectance, and a second axis is encoded by time.

[0029] Figures 9-22 relate to a system and method for locating a vessel, and may also use the technique of creating a transverse spectrally encoded line across the vessel described in the system/method of Figures 1-8. Furthermore, a 2D image of the vessel and particles formed has one axis encoded by time as per the system/method of Figures 1-8. Accordingly, it has been decided to first describe the Figures 1-8. Nevertheless, Figures 1-8 show only one example of sensing, whereas the system and method per Figures 9-22 may use other types of sensing techniques, including light as well as ultrasound. For example, a type of sensing technique is photo-acoustic detection. In some embodiments, the sensors may be 1-dimensional, 2-dimensional or 3-dimensional sensors, and may be placed at multiple points along the capillary. Optionally, the sensors are aligned according to capillary

axis, but may not apply to all sensors.

[0030] Referring now to the drawings, Fig. 1 schematically illustrates a functional block diagram of an exemplary system **100** for imaging a vessel **116**. System **100** includes a light source **102**, an imaging probe **106** including optical elements **107**, a detection unit **110**, a processor unit **112**, and a display unit **114**.

[0031] According to an embodiment of the present invention, system **100** acquires an image of one or more of a same type, or optionally a different type, of particles flowing in vessel **116**, for example as shown by particles **120**, **122** and **124** in body fluid **118**, by laterally statically illuminating a portion of the vessel with an illuminating light **108** produced by light source **102**, and detecting an emitted light (not shown) produced by the particles. Optionally, system **100** acquires an image of vessel **116**. Optionally, system **100** includes a use of SEE. Optionally, system **100** includes a use of SECM. Particles **120-124** may include red blood cells, white blood cells, virus cells, amoeba, germ cells, bacteria, toxins, medicines, nanoparticles, DNA, RNA, among other microscopic particle visible in lights. Vessel **116** may include veins, arteries, venules, arterioles, capillaries, artificial vessels, microfluidic systems, lymph, urinary tract, and other ducts internal, or optionally external, to the body and which may carry body fluids and particles.

[0032] Illuminating of the portion of vessel **116** may be performed by imaging probe **106**, which may include for example, an endoscope, optionally a catheter. Illuminating light **108**, which may include a broadband illuminating light or a wavelength-swept illuminating light, is guided from light source **102** to imaging probe **106** by an optical waveguide **104**, which may include, for example a single optical fiber, or optionally, multiple optical fibers. Optical fiber **104** may be a single-mode optical fiber or optionally, a multi-mode optical fiber. Optionally, optical waveguide **104** may comprise reflecting mirrors and/or other optical elements suitable for directing light. Illuminating light **108** is spectrally dispersed along an x-axis and/or a y-axis of vessel **116** by optical elements **107** in imaging probe **106** which include a diffraction grating. Optionally, illuminating light **108** is spectrally dispersed along a z-axis. Illumination light **108** may comprise a wavelength in the range from 600 nm-1.3 μm . A potential advantage of using light of greater wavelength is a reduction in scattering and an increase in depth range.

[0033] Imaging probe **106** additionally collects the emitted light from particles **120-124**, and optionally from vessel **116**, and optically converts the emitted light using optical elements **107** for guiding to detection unit **110**. The emitted light may include, but not be limited to, fluorescence, second harmonic generation, third harmonic generation, luminescence, coherent anti-Stokes Raman scattering, Raman scattering, multi-photon fluorescence, phosphorescence, or any combination thereof. Optionally, capturing of emitted light is done by a second light capturing probe. Guiding of the emitted light from imaging probe **106** to detection unit **110** is done through

optical fiber **104**. Optionally, guiding is done through a second optical fiber, which may be a single-mode optical fiber, or optionally, a multi-mode optical fiber.

[0034] Emitted light captured by imaging probe **106** is detected by detection unit **110**, and an output associated with a measure of a spectrum of the emitted light is generated for processing by processing unit **112**. Detection unit **110** is selected according to the emitted light to be detected, and may include a spectrometer for measuring a distinct spectral band in the emitted light, a CCD camera for capturing a single shot of the emitted light, or a single detector for measuring a discrete wavelength of the emitted light, or any combination thereof. The emitted light may also be subject to low coherence interferometry with a reference light in reference arm **115** so that an axial (z-axis) location of particles **120-124** may be determined and used to obtain a 3D image. Optionally, an axial component of a speed of particles **120-124** is determined. Optionally, Doppler imaging is used to acquire the axial component of the speed of the particle.

[0035] According to an embodiment of the present invention, processing unit **112** processes the output from detection unit **110** and reproduces the acquired image of particles **120-124**, and optionally vessel **116** and/or body fluid **118**, for display on display unit **114**. The reproduced image may be a cross-sectional 2D image along an x-axis and a y-axis, or optionally a 3D image (depth along a z-axis), of particles **120-124**. The reproduced image may additionally comprise a cross-sectional 2D image, or optionally a 3D image, of the portion of vessel **116** and/or body fluid **118**. Optionally, the reproduced image may include information related to the velocity of the particles.

[0036] According to an embodiment of the present invention, system **100** performs *in vivo*, and optionally *ex vivo*, flow cytometry. Based on the output of detection unit **110**, processing unit **112** may simultaneously count, and optionally examine, particle **120-124**, and may compute a number of particles of different types in vessel **116**, and optionally, their location, speed of flow, length, shape, color, or brightness, or any combination thereof. The results of the computation may be displayed in display unit **114**. Optionally, the results may be stored in magnetic media or other data storage means, printed, displayed by means other than display unit **114**, or any combination thereof.

[0037] Reference is made to Fig. 2 which schematically illustrates a functional block diagram of an exemplary system **200** for imaging a vessel **216** using a broadband light source **202**, in accordance with the embodiments of the present invention. Vessel **216** is shown under tissue **217**, and comprises body fluid **218** and particles **220**, **222** and **224**, which may be similar to that shown in Fig. 1 at **116**, **118**, **120**, **122**, and **124**.

[0038] System **200**, which may be similar to that shown in Fig. 1 at **100**, comprises broadband light source **202** which may include a super-luminescent diode array; an optical waveguide **204** which may include an optical fiber;

an imaging probe **206** including optical elements comprising a diffraction grating **207A** for diffracting illuminating light **208**, a collimator **207B** for collimating the illuminating light, and a high NA focusing lens **207C** for focusing the illuminating light; a spectrometer **210** including a CCD camera **210C**, a collimator **210A** for collimating an emitted light **209** and a diffraction grating **210B** for diffracting the emitted light; a processing unit **212**; and a display unit **214**. Broadband light source **202**; optical waveguide **204**; imaging probe **206** including diffraction grating **207A**, collimator **207B**, and lens **207C**; CCD camera **210** with collimator **210A** and diffraction grating **210B**; processing unit **212**; and display unit **214**; may be similar to that shown in Fig. 1 at **102**, **104**, **106** including **107**, **110**, **112**, and **114**.

[0039] According to some embodiments of the present invention, single-shot line imaging, and fast confocal imaging across vessel **216** is performed, without any scanning mechanism. Broad bandwidth illuminating light from light source **202** is coupled to optical fiber **204**, collimated, spectrally diffracted and focused onto a transverse line (focal line) within a flow of body fluid **218** and particles **220-224** inside vessel **216**, where each resolvable point on the line contains a single wavelength (each point is illuminated by a distinct spectral band). Emitted light **209** from each line is collected by imaging probe **206**, coupled back into fiber **204**, and measured by fast spectrometer **210**. An output of spectrometer **210** is processed by processing unit **212** and displayed on display unit **214**.

[0040] Fig. 3 schematically illustrates a functional block diagram of an exemplary system **300** for imaging a vessel **316** using a broadband light source **302** and a reference arm **315**, in accordance with some embodiments of the present invention. Vessel **316** is shown under tissue **317**, and comprises body fluid **318** and particles **320**, **322** and **324**, which may be similar to that shown in Fig. 1 at **116**, **118**, **120**, **122**, and **124**.

[0041] System **300**, which may be similar to that shown in Fig. 1 at **100**, comprises a broadband light source **302** which may include a super-luminescent diode array; an optical waveguide **304** which may include an optical fiber; an imaging probe **306** including optical elements comprising a diffraction grating **307A** for diffracting illuminating light **308**, a collimator **307B** for collimating the illuminating light, and a focusing lens **307C** for focusing the illuminating light; a spectrometer **310**; a processing unit **312**; a display unit **314**; and reference arm **315**. Broadband light source **302**; optical waveguide **304**; imaging probe **306** including diffraction grating **307A**, collimator **307B**, and lens **307C**; spectrometer **310**; processing unit **312**; display unit **314**; and reference arm **315**; may be similar to that shown in Fig. 1 at **102**, **104**, **106** including **107**, **110**, **112**, **114**, and **115**.

[0042] Low coherence interferometry in the range of 1 μ m-10 mm, inclusively, is used to achieve depth information (3D topological information). The interferometry may be in the time domain and/or spectral domain. Reference arm **315**, which may be included in a single-mode

Michelson interferometer, creates interference between emitted light (not shown) from illuminated particles **320-324**, and optionally from vessel **316** and/or body fluid **318**, and a reference light, which allows for processing unit **312** determination of an axial (z-axis) location of the particles. Optionally, reference arm **315** may be included in a multi-mode Michelson interferometer. Optionally, reference arm **315** may be included in any other type of interferometer suitable for creating the interference. Optionally, system **300** sensitivity is increased. Optionally, system **300** imaging speed is increased. Optionally, a lower numerical aperture lens **307C** may be used, reducing a complexity of system **300** and increasing a depth range. Optionally, Doppler imaging is used to determine the axial component of the velocity of the particle.

[0043] Broad bandwidth illuminating light from light source **302** is coupled to optical fiber **304**, collimated, diffracted and focused within a flow of body fluid **318** and particles **320-324** inside vessel **316**, where each resolvable point on the line contains a single wavelength. Emitted light (not shown) is collected by imaging probe **306**, coupled back into fiber **304** and into reference arm **315**, and measured by spectrometer **310**. An output of spectrometer **310** is processed by processing unit **312** and displayed on display unit **314**, and may include a 3D image or particles **320-324**, vessel **316**, or body fluid **318**, or any combination thereof.

[0044] Fig. 4 schematically illustrates a functional block diagram of an exemplary system **400** for imaging a vessel **416** using a wavelength-swept light source **402**. Vessel **416** is shown under tissue **417**, and comprises body fluid **418** and particles **420**, **422** and **424**, which may be similar to that shown in Fig. 1 at **116**, **118**, **120**, **122**, and **124**.

[0045] System **400**, which may be similar to that shown in Fig. 1 at **100**, comprises a wavelength-swept light source **402** for producing illumination light of varying discrete wavelengths; an optical waveguide **404** which may include an optical fiber; an imaging probe **406** including optical elements comprising a diffraction grating **407A** for diffracting illuminating light **408**, a collimator **407B** for collimating the illuminating light, and a focusing lens **407C** for focusing the illuminating light; a detection unit **410** which may include a single-element photo detector; a processing unit **412**; and a display unit **414**. Wavelength-swept light source **402**; optical waveguide **404**; imaging probe **406** including diffraction grating **407A**, collimator **407B**, and lens **407C**; photo detector **410**; processing unit **412**; and display unit **414**; may be similar to that shown in Fig. 1 at **102**, **104**, **106** including **107**, **110**, **112**, and **114**.

[0046] Confocal imaging of a diffracted wavelength-swept illumination light **408** is done by relatively rapidly changing the wavelength of the light such that every point along a focal line in vessel **416** is illuminated (encoded) with a different wavelength while scanned one point at a time. By using point-by-point illumination, a need for spectral detection of the emitted light is eliminated and

detection may be performed by a single-element photo detector **410**.

[0047] Wavelength-swept illuminating light from light source **402** is coupled to optical fiber **404**, collimated, diffracted and focused point-by-point within a flow of body fluid **418** and particles **420-424** inside vessel **416** such that each point is illuminated one-at-a-time by light of a single wavelength (by scanning one at a time). Emitted light (not shown) from each point in each line is collected one-by-one by imaging probe **406**, coupled back into fiber **404**, and measured by single-element photo detector **410**. An output of photo detector **410** is processed by processing unit **412** and displayed on display unit **414**.

[0048] Fig. 5 schematically illustrates a functional block diagram of an exemplary system **500** for imaging a vessel (not shown) using a wavelength-swept light source **502**, and a single-mode optical waveguide **504A** and a multi-mode optical waveguide **504B** for guiding an illumination light **508A** and an emitting light **508B**, respectively.

[0049] System **500**, which may be similar to that shown in Fig. 1 at **100**, comprises wavelength-swept light source **502** for producing illumination light of varying discrete wavelengths; single-mode optical waveguide **504A** and multi-mode optical waveguide **504B** which may each include an optical fiber; an imaging probe **506** including optical elements comprising a diffraction grating **507A** for diffracting illuminating light **508A**, a collimator **507B** for collimating the illuminating light, a focusing lens **507C** for focusing the illuminating light, a coupler **507D** for coupling emitting light **508B** to optical fiber **504B**, and a beam splitter **507E** for splitting the emitted light; a detection unit **510** which may be a single-element photo detector; a processing unit **512**; and a display unit **514**. Optionally, beam splitter **507E** may be a dichroic mirror for fluorescence detection. Wavelength-swept light source **502**; optical waveguides **504A** and **504B**; imaging probe **506** including diffraction grating **507A**, collimator **507B**, lens **507C**, coupler **507D**, and beam splitter **507E**; photo detector **510**, processing unit **512**, and display unit **514**, may be similar to that shown in Fig. 1 at **102**, **104**, **106** including **107**, **110**, **112**, and **114**.

[0050] System **500** is configured such that a proximal unit **501** includes light source **502**, photo detector **510**, processing unit **512**, and display unit **514** with imaging probe (distal unit) **506** distally located. Connection of imaging probe **506** to proximal unit **501** is through optical fibers **504A** and **504B**.

[0051] According to some embodiments of the present invention, single-mode optical fiber **504A** is used for high-resolution illumination while multi-mode optical fiber **504B** with a larger core collects a backscattered/fluorescence emitted light **508B** after passing through beam splitter **507E**, optionally the dichroic mirror. Wavelength-swept illuminating light from light source **502** is coupled to optical fiber **504A**, collimated, diffracted and focused onto a transverse line (focal line) in a vessel (not shown), where each resolvable point on the line contains a single

wavelength (each point is illuminated by one by one by scanning one at a time). Emitted light (not shown) from each point in each line is collected one-by-one by imaging probe **506**, split into separate beams by beam splitter **507E**, optionally the dichroic mirror, and coupled into multi-mode optical fiber **504B**. The beams are measured by single-element photo detector **510** and an output of the photo detector is processed by processing unit **512** and displayed on display unit **514**.

[0052] Fig. 6 schematically illustrates a functional block diagram of an exemplary system **600** for imaging a vessel (not shown) using a wavelength-swept light source **602**, and a single-mode optical waveguide **604A** and a multi-mode optical waveguide **604B** for guiding an illumination light **608A** and an emitting light **608B**, respectively.

[0053] Spatially separating between fluorescence in the illuminated particle and/or illuminated vessel, and an illuminating light **608A**, allows for using system **500** shown in Fig. 5 without a beam splitter. Therefore, system **600** may be similar to system **500** with the exception that the system does not include beam splitter **507E** shown in Fig. 5.

[0054] System **600** comprises wavelength-swept light source **602** for producing illumination light of varying discrete wavelengths; single-mode optical waveguide **604A** and multi-mode optical waveguide **604B** which may each include an optical fiber; an imaging probe **606** including optical elements comprising a diffraction grating **607A** for diffracting illuminating light **608A**, a collimator **607B** for collimating the illuminating light, a focusing lens **607C** for focusing the illuminating light, and a coupler **607D** for coupling emitting light **608B** to optical fiber **604B**; a detection unit **610** which may be a single-element photo detector; a processing unit **612**; and a display unit **614**. Wavelength-swept light source **602**; optical waveguides **604A** and **604B**; imaging probe **606** including diffraction grating **607A**, collimator **607B**, lens **607C**, and coupler **607D**; photo detector **610**, processing unit **612**, and display unit **614**, may be similar to that shown in Fig. 5 at **502**; **504A**; **504B**; **506** including **507A**, **507B**, **507C**, and **507D**; **510**, **512**, and **514**.

[0055] System **600** is configured such that a proximal unit **601** includes light source **602**, photo detector **610**, processing unit **612**, and display unit **614** with imaging probe (distal unit) **606** distally located. Connection of imaging probe **606** to proximal unit **601** is through optical fibers **604A** and **604B**.

[0056] Fig. 8B schematically illustrates a functional block diagram of an exemplary system **2200** for spread-spectrum interferometric imaging of particle flow. Embodiments of method and construction for spread-spectrum interferometric imaging of particle flow are also shown in "High-speed interferometric spectrally encoded flow cytometry" by L. Golan et al, Optics Letters 37 No. 24, December 15, 2012. In an exemplary embodiment, the system includes an illumination light source **2202** capable of producing a plurality of relatively limited wave-

length ranges in rapidly changing ordered or non-ordered succession throughout a wider sweep range. Said illumination light source may be a wavelength-swept light source. The system further comprises interferometric apparatus 2215. The interferometric apparatus 2215 may include the reference arm of a single-mode Michelson interferometer or other interferometer type. The interferometry the interferometric apparatus helps perform may be low coherence interferometry operating within a coherence range of 1 μm -10 mm, inclusively; for example, in the range of 1 μm up to 10 μm , or up to 100 μm .

[0057] During imaging, the output wavelength range of the illumination light source 2202 is changed relatively rapidly throughout its sweep range, which in one embodiment may be 1005-1115 nm. In other embodiments, it may be a range with a center wavelength between 800 and 1300 nm inclusive, and a bandwidth between 10 and 300 nm inclusive. In some embodiments of the invention, the choice of the range is made to reduce or control light scattering, and/or to increase or reduce absorption by one or more components of the target vessel, its environs, or the particles within it; for example, for an advantage in light penetration to the target, or in extracting spectral information about the particles.

[0058] In one embodiment, scanning through said sweep range occurs at 100 KHz. In other embodiments, said sweep range is above 10 KHz. In an exemplary embodiment of the invention, a light source 2202 is coupled to optical waveguide 2204, which may be an optical fiber, through which the illumination light 2208 enters the probe 2206.

[0059] In some embodiments, the illumination light is collimated at collimator 2207B, and directed toward dispersing element 2207A, which may be a diffraction grating, that spectrally disperses said light. The angle at which light leaves the dispersing element 2207A varies with wavelength, such that points along an axial line in vessel 2216, to which the light is focused to by focusing lens 2207C, are illuminated (encoded) with different wavelengths, one wavelength-determined axial location at a time.

[0060] Light returning or emitted from illuminated particles 2220-2224, and optionally from vessel 2216 and/or body fluid 2218, is coupled back into optical waveguide 2204. In an exemplary embodiment of the invention, an interferometric apparatus 2215 creates interference between the returned or emitted light (not shown) and a reference light. In this exemplary embodiment, the light received at the detection unit, 2210, may thus encode, by its intensity and time of arrival, the position and relative reflectance or other light-interaction properties of tissue, fluid, and particles along the illuminated axis.

[0061] In some embodiments, conversion of this encoded information to an image occurs in the processing unit 2212. Demodulation may be by means of a discrete Hilbert transform, a Fourier transform, or another demodulating transformation. From the demodulated data, a line image may be formed from which the axial location of

the particles may be determined. By placing line scans in sequential apposition, a two-dimensional (2D) image may be formed for display by display unit 2214. Further particle, tissue, and fluid measurements, including determinations of optical properties, may be performed on the original or on the demodulated data.

[0062] Previous reference has been made to the axial location of particles and other components of the vessel or its environs, which may be along a z-axis, pointing orthogonally away from the imaging probe, an x-axis, running substantially perpendicular to the length of a vessel, a y-axis, running substantially parallel to the length of a vessel, or any non-principal axis. The axial location may also be considered with respect to the axis of spectral dispersion, which may be curved or discontinuous in space. The wavelengths which fall on or within an illuminated vessel are not necessarily all of those which an embodiment of the system produces. Some wavelength information regarding the vessel may in this case be unobtainable without further steps or elements. This problem may be addressed in an exemplary embodiment by changing the positioning of optical elements to focus the line of illumination to be smaller or larger, and in another exemplary embodiment by changing the position of optical elements to rotate the line relative to the positioning of the probe. In some embodiments, within any limits that may be imposed by the vessel's situation and the probe's size and construction, the line may also be rotated by changing the positioning of the probe itself. By one of these or similar methods, the illumination of the vessel 2216 may be aligned along an at least partially longitudinal axis of the vessel, in this and other embodiments. This brings more of the spectral range of the illuminating light to bear upon targets within the vessel, providing an advantage for determining the optical property of color (spectrum) by the processing unit 2212.

[0063] In this and other embodiments, where at least one set of imaged particles, such as red blood cells, is substantially the same in color (spectrum) properties within the imaged region, the partial spectral information available for each particle (based on the relative return of light across the range of illuminating wavelengths) may be combined by processing unit 2212, for example by time-averaging at a plurality of spectral ranges, to make a combined assessment of the spectral properties of the set. In the case of red blood cells, for example, spectral properties depend on a level of oxygen saturation.

[0064] By means of the interferometric imaging embodiment just described for the system 2200, sensitivity and imaging speed are increased over some other embodiments. This may permit the determination, for example, of faster flow rates (appropriate to small veins and arteries) up to about 10 mm/s, where different embodiments, such as some that rely on a broad-band light, determine flow rates (appropriate chiefly to capillaries) only up to about 1.5 mm/s. Optionally, Doppler measurement is used to determine the axial component of the velocity of the particle.

[0065] Reference is made to Figure 7A which schematically illustrates an exemplary single-event histogram from a cytometer, as known in the art, and to Figure 7B which schematically illustrates an exemplary cross-sectional image along an x-axis and a y-axis of the of a vessel acquired by any one of system **100-600** shown in Figs. 1-6, in accordance with an embodiment of the present invention. The single-event histogram shown in Fig. 7A is based on a use of a single laser beam aimed at a hydrodynamically-focused stream of fluid for counting particles one-by-one. From the cross-sectional image shown in Fig. 7B, additional information on particles aside from their number, such as for example, type, size, shape, location in the vessel, color, brightness, and the like, may be readily obtained. The additional information may be used to increase the speed of measurement by increasing the flow rate, its accuracy, and for the implementation of new cell collection systems that may use this information for more efficient and accurate cell sorting.

[0066] Reference is made to Fig. 8A which illustrates a flow chart of an exemplary method for acquiring an image of a particle in a vessel. Reference is also made to Fig. 1. It should be evident to a person skilled in the art that the exemplary method described herein may be implemented in other ways, forms, and/or manners, and is therefore not intended to be limiting to the method described.

[0067] At 801, illumination light 108 is produced by light source 102 and sent over optical waveguide 104 to imaging probe 106 which may include an endoscope or a catheter. Illumination light 108 may be a broadband light or a wavelength-swept light. Optical waveguide 104 may be a single-mode optical fiber. Optionally, waveguide 104 may be a multi-mode optical fiber.

[0068] At 802, illumination light 108 is received by imaging probe 106 where the light is collimated by a collimator and spectrally diffracted by a diffracted grating in optical element 107. Optionally, illumination light 108 is not collimated.

[0069] At 803, a portion of vessel 116 is illuminated by illumination light 108, the light spectrally dispersed along the x-axis of the vessel.

[0070] At 804, particles 120-124, and optionally illuminated vessel 116 and/or body fluids 118, produce emitted light responsive to being illuminated by illumination light 108. Imaging probe 106 collects (captures) the emitted light which is optically processed by optical element 107 for sending through optical fiber 104 to detection unit 110. Optionally, the emitted light may be sent to reference arm 115 for creating an interference with a reference low coherency light for obtaining axial information (along a z-axis) on the illuminated particle 120-124 and/or illuminated vessel 116, for reproduction of a 3D image. Optionally, the axial component of the speed of the particle is determined.

[0071] At 805, emitted light is detected by detection unit 110. Detection unit 110 may include a spectrometer

for measuring a distinct spectral band in the emitted light, a CCD camera for capturing a single-shot image of the emitted light, a single-element photo detector for measuring a discrete wavelength of the emitted light, or any combination thereof. Detection unit 110 generates an output to processing unit 112 based on the measurements.

[0072] At 806, processing unit 112 processes the output received from detection unit 110 and reproduces the image of illuminated particle 120-124 and/or illuminated vessel 116. Processing unit 112 performs all computations associated with flow cytometry, including substantially simultaneous determination of a number of particles, and other characteristics such as their type, size, shape, color, brightness, and the like.

[0073] At 807, display unit 114 displays information from processing unit 112. The information may be the 2D cross-sectional image of illuminated particle 120-124, illuminated vessel 116, body fluid 118, or any combination thereof, and optionally the 3D image. Optionally, flow cytometry information computed by processing unit 112 is displayed.

[0074] Before explaining at least one embodiment of the invention in detail, it is to be understood that the invention is not necessarily limited in its application to the details set forth in the following description or exemplified by the Examples. The invention is capable of other embodiments or of being practiced or carried out in various ways.

[0075] Referring now to the drawings, Figure 9 schematically illustrates an imaging probe 901 used in an imaging system 900 for locating a vessel, according to an exemplary embodiment of the invention. Optionally, imaging probe 901 is used non-invasively to locate a relatively deep vessel on a living subject. In some embodiments, the vessel may be at a depth of up to 100 μm below a tissue surface. Optionally, the vessel may be at an even greater depth up to 200 μm . The vessel may include any type of blood vessel, and may be a capillary or an arteriole. Additionally or alternatively, imaging probe 901 may be used for performing *in vivo* SEFC. In some embodiments, imaging probe 901 is a handheld probe. Alternatively, imaging probe 901 is an endoscopic probe or a catheter probe.

[0076] Imaging probe 901 houses a detection unit 902 and a background light source 904. Detection unit 902 may include a CCD camera, CMOS camera, or any other type of image acquisition device known in the art sized for being housed in the imaging probe and adapted to detect backscattered background light. Background light source 904 may include a LED which produces a background light 906 which is green, or may optionally be any other suitable green light source known in the art. Optionally, background light source 904 may generate background light 906 of red color. As described below, the illumination using the background light may share an optical pathway and/or line of sight with an optical sensor used to analyze properties of the blood flow.

[0077] Imaging probe **901** is externally connected to an illuminating light source (not shown) in system **900** through an optical fiber **908** and through which an illuminating lighting **912** is fed to the imaging probe. Optionally, optical fiber **908** is a single-mode optical fiber. Imaging probe **901** is externally connected to a processing unit (not shown) through a second optical fiber **910** and through which illuminating light backscatter **913** is fed to the processing unit. Optionally, optical fiber **910** is a single-mode optical fiber. Optionally, fiber **910** is a multi-mode optical fiber.

[0078] In an exemplary embodiment of the invention, imaging probe **901** includes a common optical channel **930** interconnecting aperture **931** with combiner/splitter **916**; an illuminating optical channel **934** interconnecting a beam splitter **915** with the combiner/splitter; and a background light optical channel **932** interconnecting a beam splitter **925** with the combiner/splitter; all three channels configured for handling illumination and backscattering lighting.

[0079] An example of imaging probe **901** operation may include combining green light **906** from background light source **904** with illuminating light **912** at beam combiner **916**, collimating background light **906** and illuminating light **912** at collimator **918**, diffracting illuminating light **912** at diffraction grating **920**, and focusing by means of objective lens **922** spectrally dispersed illuminating light **912** and green light **906** to a transverse line on a portion of the vessel section. Diffraction grating **920** may in some embodiments be replaced with a combination of a mirror at **920**, and a separate transmission diffraction grating, **920A**. In further embodiments, diffraction grating **920** may be replaced by a mirror at **920**, and a separate transmission diffraction grating **934A** may be placed among the optical elements which comprise optical channel **934**. A backscattered light from the tissue is captured by imaging probe **901** through objective lens **922** and may be collimated in collimator **924**, split by beam combiner **916**, with the backscattered background light **924** directed through beam splitter **926** into detector **902**, and the backscattered illuminating light **913** directed through beam splitter **915** to optical fiber **910**. In some embodiments, all optical components are stationary and are not mechanically movable. Alternatively, objective lens **922** may be mechanically moved for focusing illuminating light **912** and green light **906** to the transverse line.

[0080] Reference is now made to Figure 10 which schematically illustrates an imaging probe **1001** used in an imaging system **1000** for locating a vessel, according to an exemplary embodiment of the invention. Optionally, imaging probe **1001** is used non-invasively to locate a relatively deep vessel on a living subject. Additionally or alternatively, imaging probe **1001** may be used for performing *in vivo* SEFC. In some embodiments, imaging probe **1001** is a handheld probe. Alternatively, imaging probe **1001** is an endoscopic probe or a catheter probe.

[0081] Imaging probe **1001** houses a detection unit **1002**, a background light source **1004**, and a processing

unit **1005**. Detection unit **1002** may include a CCD camera, CMOS camera, or any other type of suitable image acquisition device known in the art sized for being housed in the imaging probe, and may include a display for displaying a 2D image of the illuminated portion of the vessel and/or of the particles. Background light source **1004** may include a LED which produces a light **1006** which is green, or may optionally be any other suitable green light source known in the art. Optionally, background light source **1004** may generate light **1006** of red color. Processing unit **1005** may process data generated by detection unit **1002** responsive to detection of a back-scattered light **1024**, for generating the displayed image optionally on the display of detection unit **1002**.

[0082] In an exemplary embodiment of the invention, imaging probe **1001** is externally connected to an illuminating light source and a processing unit (both not shown) in system **1000** through an optical fiber **1008** connected to an optical fiber connector **1009** in the probe. Optionally, optical fiber **1008** is a single-mode optical fiber.

[0083] In an exemplary embodiment of the invention, imaging probe **1001** includes a common optical channel **1030** interconnecting aperture **1031** with combiner/splitter **1016**; an illuminating optical channel **1034** interconnecting optical fiber connector **1009** with the combiner/splitter; and a background light optical channel **1032** interconnecting a beam splitter **1026** with the combiner/splitter; all three channels configured for handling illumination and backscattering lighting.

[0084] An example of imaging probe **1001** operation may include combining green light **1006** from background light source **1004** with illuminating light **1012** at beam combiner **1016** following the lights having passed through lenses **1015**, diffracting illuminating light **1012** at diffraction grating **1020**, and focusing by means of objective lens **1022** spectrally dispersed illuminating light **1012** and green light **1006** to a transverse line on a portion of the vessel section. A backscattered light **1024** from the tissue is captured by imaging probe **1001** through objective lens **1022** and split by beam combiner **1016** with the background backscatter light through beam splitter **1026** into detector **1022**, and the illuminating backscatter light going to optical fiber connector **1009**. In some embodiments, all optical components are stationary and are not mechanically movable. Alternatively, objective lens **1022** may be mechanically moved for focusing illuminating light **1012** and green light **1006** to the transverse line.

[0085] Reference is now made to Figure 11 which schematically illustrates an imaging probe **1101** used in an imaging system **1100** for locating a vessel, according to an exemplary embodiment of the invention. Optionally, imaging probe **1101** is used non-invasively to locate a relatively deep vessel on a living subject. Additionally or alternatively, imaging probe **1101** may be used for performing *in vivo* SFEC. In some embodiments, imaging probe **1101** is a handheld probe. Alternatively, imaging probe **1101** is an endoscopic probe or a catheter probe.

[0086] Imaging probe 1101 is externally connected to an illuminating light source and a processing unit (both not shown) in system 1100 through an optical fiber 1108 connected to an optical fiber connector 1109 in the probe. Optionally, optical fiber 1108 is a single-mode optical fiber. Additionally, imaging probe 1101 is externally connected to a background light source (not shown) in system 1100 through an optical fiber 1107 connected to an optical fiber connector 1109 in the probe. Optionally, optical fiber 1107 is a multi-mode optical fiber. Additionally, imaging probe 1101 is externally connected to a processing unit (not shown) in system 1100 through an optical fiber 1111 connected to an optical fiber connector 1109 in the probe. Optionally, optical fiber 1111 is an optical fiber bundle. In some embodiments, optical fiber bundle 1111 is connected to a spectrometer (not shown).

[0087] In an exemplary embodiment of the invention, imaging probe 1101 includes a common optical channel 1030 interconnecting aperture 1131 with combiner/splitter 1116; an illuminating optical channel 1134 interconnecting optical fiber connector 1109 and optical wire 1108 with the combiner/splitter; and a background light optical channel 1132 interconnecting a beam splitter 1126 with the combiner/splitter; all three channels configured for handling illumination and backscattering lighting. Imaging probe 1101 includes two separate optical channels which connect to beam splitter 1126, a background light channel 1136 connecting optical fiber 1107 to splitter 1126, and a background backscatter channel 1135 connecting optical fiber bundle 1111 to splitter 1126.

[0088] An example of imaging probe 1101 operation may include combining green light 1106 arriving through optical fiber 1107 with illuminating light 1012 arriving through optical fiber 1108 at beam combiner 1116 following the lights having passed through lenses 1105, diffracting illuminating light 1116 at diffraction grating 1120, and focusing by means of objective lens 1122 spectrally dispersed illuminating light 1112 and green light 1106 to a transverse line on a portion of the vessel section. A backscattered light 1124 from the tissue is captured by imaging probe 1101 through objective lens 1122 with the background backscatter light diverted by beam combiner 1116 through beam splitter 1126 and through lens 1105 into optical fiber bundle 1111. The backscatter illuminating light is split by beam splitter 1116 to optical fiber 1108. In some embodiments, all optical components are stationary and are not mechanically movable. Alternatively, objective lens 1122 may be mechanically moved for focusing illuminating light 1112 and green light 1106 to the transverse line.

[0089] Reference is now made to Figure 12 which schematically illustrates an imaging probe 1201 used in an imaging system 1200 for locating a vessel, according to an exemplary embodiment of the invention. Imaging probe 1201 is similar to imaging probe 1101 in Figure 11 with an additional feature of a handle 1220 for mechanically attaching the probe to a stationary fixture, thereby preventing its movement. This feature optionally allows

for better maintaining the probe focused on the transverse line on the portion of the vessel section. In some embodiments, handle 1120 is affixed to a body section of a live subject being imaged, for example, to a leg, an arm, or on the body. Optionally, when attached to the body portion, relative moment between the probe and the tissue is substantially reduced. Although handle 1220 is shown as part of imaging probe 1201, the handle may readily be included in any of the embodiments of the imaging probes described herein.

[0090] Reference is now made to Figure 13 which schematically illustrates an imaging probe 1301 used in an imaging system 1300 for locating a vessel, according to an exemplary embodiment not falling within the scope of the claims. Imaging probe 1301 is similar to imaging probe 1101 in Figure 11 with an additional feature of a vacuum suction mechanism 1302 which substantially minimizes tissue movement when operated by suctioning the tissue against the probe. Optionally, vacuum suction mechanism 1302 provides a low pressure sectional force, and may be used alternatively or additionally to the handle 1220 or with other probe designs.

[0091] Vacuum suction mechanism 1302 may include a plunger 1304 positioned inside a chamber 1306 connecting through a conduit 1308 to a suction cap 1310. Suction cap 1310 is placed around an opening 1312 bordering an objective lens 1322 and through which illuminating light and background light are transmitted to the vessel. Suction cap 1310 optionally includes an opening or a section with optical transparency. Alternatively, imaging is to the side of the opening, 1314 through which the transmitted light and the backscattered light may pass, optionally with minimal interference, in and out of the imaging probe. Suction cap 1310 further includes openings 1312 which align with conduit 1308 and through which air may flow in and out of the conduit. For creating a vacuum for drawing the tissue toward imaging probe 1301, plunger 1304 is pulled in a proximal direction, thereby drawing the tissue towards the probe. Pushing plunger 1304 in a distal direction will remove the vacuum. In some embodiments, vacuum suction mechanism 1302 may be electrically powered, and may include AC and/or DC. Alternatively, vacuum suction mechanism 1302 may be replaced by other means for maintaining the tissue relatively, for example, by temporarily adhering the tissue to the imaging probe with an adhesive or the like. In some embodiments, the adhesive is part of the probe and the probe or its casing is disposable following one or repeated uses.

[0092] In an exemplary embodiment of the invention, fixation techniques are used to support continuous monitoring, for example, fixation is provided which allows sensing for, for example, 1, 5, 10, 30, 60, 120 or smaller or intermediate number of seconds, or more, for example, 3 minutes, 5 minutes, 15 minutes, up to an hour, 1-10 hours and/or during bed rests and/or movement or exercise. Data logging for such periods of time may be provided in a control circuitry (e.g., using a memory and/or

processing unit thread).

[0093] In an exemplary embodiment, the probe includes a strap, an elastic band or a place to attach an adhesive band, to allow compressive fixation to tissue. This may be in addition to or instead of an adhesive layer between the probe and the tissue.

[0094] Reference is now made to Figure 14 which schematically illustrates an imaging probe **1401** used in an imaging system **1400** for locating a vessel, according to an exemplary embodiment of the invention. Optionally, imaging probe **1401** is used non-invasively to locate a relatively deep vessel on a living subject. Additionally or alternatively, imaging probe **1401** may be used for performing *in vivo* SEFC. In some embodiments, imaging probe **1401** is a handheld probe. Alternatively, imaging probe **1401** is an endoscopic probe or a catheter probe.

[0095] Imaging probe **1401** is configured for receiving a background light **1406** and for transmitting a backscattered light **1426** through a same optical channel. Imaging probe **1401** is externally connected to an illuminating light source (not shown) in system **1400** through an optical fiber **1408** for receiving illuminating light **1412**. Optionally, optical fiber **1408** is a single-mode optical fiber. Additionally, imaging probe **1401** is externally connected to a background light source (not shown) and to a processing unit (not shown) in system **1400** through an optical fiber **1411**. Optionally, optical fiber **1411** is an optical fiber bundle. Optionally, optical fiber bundle **1411** is connected to a spectrometer (not shown). Optionally, the functions of the spectral dispersing element and the beam combining element are combined in one combining-dispersing element **1420**, which may be a transmissive diffraction grating, and accordingly both combines and spectrally disperses said background light **1406** and said illuminating light **1412** before they are directed to the probe objective **1422**.

[0096] Above have been described several embodiments of imaging probes which may be included in a system for locating vessels. The described embodiments are exemplary and an ordinary person skilled in the art may find that there are many ways of implementing the features described herein, for example, other designs may be used which integrate a vessel finding optical sensor with a vessel analyzing optical sensor, for example, in fixed relationship and with shared optical pathways and/or lines of sight, and/or as part of a microscope. Reference is made to Fig. 15 which illustrates a flow chart of an exemplary method for locating a vessel. An ordinary person skilled in the art may appreciate that the exemplary method described herein may be implemented in other ways, forms, and/or manners.

[0097] At 1501, an operator of the system for locating a vessel optionally sets up the probe for use, for example, connects the imaging probe to an illumination light source and a background source by connecting respective wave guides to the probe. Illumination light and background light are transmitted over optical guides to the imaging probe. The imaging probe may include an endoscope or

a catheter. Illumination light may be a broadband light or a wavelength-swept light. Background light may be green wide-field light or a red wide-field light. The optical fiber for the illumination light may be a single-mode optical fiber. The optical fiber for the background light may be a multi-mode optical fiber. Alternatively the background light is transmitted over a fiber bundle. In some embodiments, the background light is generated by the imaging probe.

[0098] At 1502, in operation in the imaging probe the illumination light is collimated by a collimator and spectrally diffracted by a diffracted grating. Optionally, illumination light is not collimated. The illumination light is combined with the background light. Optionally, the background light is collimated.

[0099] At 1503, the system operator approximates the imaging probe to a subject's tissue for illuminating a portion of a vessel. Optionally, the vessel is relatively deep, for example, at a depth up to 200 μm . The imaging probe substantially minimizes movement of the subject's tissue relative to the imaging probe. Alternatively, the operator adheres the imaging probe to the tissue using an adhesive. The operator reduces movement by pressing the probe against the tissue. Optionally, an improved view of the cells is obtained by the pressing. Optionally, the focus is improved by such pressing. The background light is partially or wholly absorbed by the particles in the vessel. Backscattering light is produced by the illuminated portion of the vessel.

[0100] In an exemplary embodiment of the invention, the operator views an image and adjusts the probe until the image includes a blood vessel. A target area of the probe is optionally aligned with the vessel, for example, by moving the probe or by motorized movement of optical line of sight changing elements in the probe. The target area is a line and is aligned to be perpendicular to an axis of the blood vessel. Optionally, pressure is applied to shape the blood vessel, for example, to compress it by 20%, 40%, 60% or greater or intermediate amounts and/or to cause certain flow characteristics therein. In an exemplary embodiment of the invention, the vessel is compressed to a flat oval shape forcing the cells to align with their narrow dimension toward the flow direction. Optionally, the shape of the vessel is sensed using the sensing ability of the probe and provided as feedback to the operator.

[0101] For efficient detection of WBCs, the depth of focus of the imaging probe is optionally positioned only a few microns below the front wall of post-capillary venules, where margined WBCs are abundant and RBCs are rarely seen. In this location, passing WBCs may be detected and automatically registered by plotting the total scattered power as a function of time (Fig. 20a). In an exemplary embodiment of the invention, use is made of the measurable WBC flux increasing with vessel diameter (Fig. 20b). Optionally, the vessel size is selected by the user to match the desired viewing. Optionally or alternatively, the system corrects measured parame-

ters based on the vessel size, for example, using a correction table. Optionally, the display includes an indication of vessel size to assist the operator in selecting a suitable vessel and/or selecting correct processing parameters.

[0102] In an exemplary embodiment of the invention, the searching for a vessel includes determining a desired vessel size and searching for a vessel of that size, for example, a capillary or a small arteriole. In an exemplary embodiment of the invention, the vessel size is, for example, between 1 and 50 microns in diameter, for example, between 2 and 20 microns in diameter.

[0103] At **1504**, the imaging probe collects (captures) the backscattered light which is then sent through an optical fiber to the detection unit. Alternatively, the detection unit is in the imaging probe or other detection mechanisms are used to collect and/or detect light by the probe. Optionally, the backscattered light may be sent to a reference arm for creating an interference with a reference low coherency light for obtaining axial information (along a z-axis) on the illuminated vessel and/or illuminated particles, for reproduction of a 3D image. Optionally, the axial component of the speed of the particle is determined. In some embodiments, the detection unit may include a spectrometer for measuring a distinct spectral band in the backscatter light, a CCD camera for capturing a single-shot image of the backscattered light against the contrast background, a single-element photo detector for measuring a discrete wavelength of the emitted light, or any combination thereof. The detection unit generates an output to the processing unit based on the measurements. Optionally, the output is sent from the image processing device through an optical guide to the processing unit. Alternatively, the processing unit is located on the image processing device together with the detection unit.

[0104] At **1505**, the processing unit processes the output received from detection unit and reproduces the image of the illuminated vessel. The processing unit performs all computations associated with imaging the vessel. Optionally, computations associated with flow cytometry, including substantially simultaneous determination of a number of particles, and other characteristics such as their type, size, shape, color, brightness, and the like are performed. In an exemplary embodiment of the invention, the target area on which such computations are performed is shown as a red line overlaid on a green image showing the blood vessels. Other colors and/or indication may be used as well.

[0105] At **1506**, the display unit displays information from the processing unit. The information may be the 2D cross-sectional image of the portion of the vessel and/or of the particles, and optionally the 3D image. The operator views the images on the display to view the particles. Optionally, the operator views the results of the computation associated with flow cytometry.

[0106] Reference is now made to Figure 22 which schematically illustrates an imaging probe **2302** used

within an imaging system for locating, for example, a vessel **2315** in a region of tissue **2316**, according to an exemplary embodiment of the invention, and also used within an imaging system for imaging and determining properties of one or more of, for example, a located vessel, and particles, tissue, and body fluid associated with the located vessel.

[0107] Optionally, imaging probe **2302** is used non-invasively to locate a relatively deep vessel on a living subject. Additionally or alternatively, imaging probe **2302** may be used for performing *in vivo* SEFC, which may be interferometric SEFC, including high-speed interferometric SEFC, such as is described in relation to figure 8B. In some embodiments, imaging probe **2302** is a handheld probe. Alternatively, imaging probe **2302** is an endoscopic probe or a catheter probe.

[0108] In an exemplary embodiment of the invention, imaging probe **2302** includes a common optical channel **2328** interconnecting the imaged region of tissue **2316** and/or vessel **2315** with beam combiner/splitter **2326**; an illuminating optical channel **2330** interconnecting the coupling point of the illuminating light optical fiber **2310** with beam combiner/splitter **2326**; and a background light optical channel **2332** inter-connecting a beam splitter **2324** with beam combiner/splitter **2326**. All three channels may be configured for handling illumination and backscattering lighting.

[0109] In some embodiments of the invention, the imaging probe **2302** houses a detection unit **2304** and a background light source **2306**. Detection unit **2304** may include a CCD camera, CMOS camera, or any other type of image acquisition device known in the art sized for being housed in the imaging probe and adapted to detect backscattered background light. Background light source **2306** may include a LED which produces a background light **2308** which is green, or may optionally be any other suitable green light source known in the art. Optionally, background light source **2306** may generate background light **2308** of red color.

[0110] Through an optical fiber **2310**, imaging probe **2302** is externally connected to an illuminating light source (not shown), which is appropriate to the chosen embodiment of the elements of the system which perform particle imaging and characterization. From optical fiber **2310**, illuminating light **2312** is fed to the imaging probe. Optionally, optical fiber **2310** is a single-mode optical fiber. After collimation by collimator **2313**, the light is spread by a wavelength dispersing element, **2314**, which may be a transmission diffraction grating. In some embodiments of the invention, a telescopic relay arrangement is provided which may be comprised of two achromatic lenses **2318A** and **2318B** guides the light to the beam combiner/splitter **2326**. By the use of the telescopic relay, the uniformity of the field of view may be improved.

[0111] An example of imaging probe **2302** operation may further include combining green light **2308** from background light source **2306** with illuminating light **2312** at beam combiner/splitter **2326**. The light may be focused

by means of objective lens **2320**, directing spectrally dispersed illuminating light **2312** to a transverse line on a portion of the vessel section, and green light **2308** to a region including that line. In an exemplary embodiment of the invention, light returned or emitted from the tissue is captured by imaging probe **2302** through objective lens **2320**. It may be split by beam combiner/splitter **2326**. The returned or emitted background light may be directed through beam combiner/splitter **2326** into detector **2304**. The returned or emitted illuminating light may be directed through to optical fiber **2310**, after which it is directed to other parts of the system, which may include elements for interferometric or spectral imaging of the light, as described, for example, with regard to exemplary systems such as **2200**.

[0112] In some embodiments, all optical components are stationary and are not mechanically movable. Alternatively, objective lens **2320** may be mechanically moved for focusing illuminating light **2312** and green light **2308** to the transverse line.

[0113] Reference is made to Figure 16 which schematically illustrates an imaging system **1600** for *in vivo* imaging, according to an exemplary embodiment of the invention.

[0114] Broadband light from a fiber-coupled super luminescent diode array **1602** (Superlum S840-B-I-20, 840 nm central wavelength, 50 nm bandwidth) was collimated into a 2.5 mm diameter beam using an aspheric lens **1606** (11 mm focal length), expanded using a 3.75× beam expander comprising lenses **1613** and **1614**, and focused onto a transverse spectral line using a transmission diffraction grating **1608** (1200 1/mm, Wasatch photonics) and a water immersion objective lens **1612** (60×, NA=1.2, Olympus). Imaging depth inside the tissue **1628** was adjusted by manually threading a protective aluminum cap **1629** with an attached 0.17 mm thick cover glass which was in contact with the tissue. The gap between the objective front element and the cover glass was filled with water. Backscattered light from the tissue was collected and collimated by the illumination optics comprising lenses **1614** and **1613** in a confocal geometry, split by a 50:50 cubic beam splitter **1616**, coupled to a single-mode collection fiber and directed to a home-built spectrometer **1618** with a high-sensitivity electron-multiplying CCD camera (DU970N, Andor, 1300 lines/s). For high acquisition rates which were required for imaging rapid cell flow, a faster CCD camera (Aviiva EM4, e2v) was used, allowing acquisition rates of up to 71,000 lines/s. The lateral resolution of the imaging probe was 0.7 μm (edge response, FWHM), the axial resolution was 1.5 μm (FWHM, measured by axially scanning a reflective surface across the focal volume), and the lateral field of view in the wavelength axis was 110 μm. The total power incident on the sample was approximately 7 mW.

[0115] The relatively small field of view of the confocal spectrally encoded line may impose a difficulty in identifying blood vessels deep below the tissue surface. In an exemplary embodiment of the invention, the location of

blood vessels is assisted by using an additional wide-field green imaging channel that was added to the probe and that shares the same objective lens. A beam from a light-emitting diode **1620** (M530L2, Thorlabs, 530 nm central wavelength) was collimated and coupled to the imaging channel using a dichroic mirror **1621** (t680dcspxr, Chroma technology). The light backscattered from the tissue was imaged using a two-dimensional CCD camera **1624** (UI-2220, IDS) at 20 frames/s. Blood vessels were observed at high contrast within a field of view of 400×300 μm² as dark regions on a bright background due to the high relative absorption of the green light by hemoglobin. A pair of crossed polarizers **1623A** and **1623B** was used to reject surface reflections to further enhance contrast.

[0116] Data from both the illuminating light and green channels were simultaneously sampled and displayed by a personal computer **1626** in real-time, using a custom built software (LabVIEW, National Instruments).

[0117] In some embodiments of the invention the display is replaced and/or enhanced by an automated system which rotates and/or aligns a target area with a blood vessel, optionally using image processing techniques to detect the blood vessel (e.g., using an on-probe processor).

[0118] Optionally, instead of a 2D imager, a scanning 1D imager is used to detect the blood vessel.

[0119] The terms "comprises", "comprising", "includes", "including", "having" and their conjugates mean "including but not limited to".

[0120] The term "consisting of" means "including and limited to".

[0121] The term "consisting essentially of" means that the composition, method or structure may include additional ingredients, steps and/or parts, but only if the additional ingredients, steps and/or parts do not materially alter the basic and novel characteristics of the claimed composition, method or structure.

[0122] Throughout this application, various embodiments of this invention may be presented in a range format. It should be understood that the description in range format is merely for convenience and brevity and should not be construed as an inflexible limitation on the scope of the invention. Accordingly, the description of a range should be considered to have specifically disclosed all the possible subranges as well as individual numerical values within that range. For example, description of a range such as from 1 to 6 should be considered to have specifically disclosed subranges such as from 1 to 3, from 1 to 4, from 1 to 5, from 2 to 4, from 2 to 6, from 3 to 6 etc., as well as individual numbers within that range, for example, 1, 2, 3, 4, 5, and 6. This applies regardless of the breadth of the range.

[0123] Whenever a numerical range is indicated herein, it is meant to include any cited numeral (fractional or integral) within the indicated range. The phrases "ranging/ranges between" a first indicate number and a second indicate number and "ranging/ranges from" a first indi-

cate number "to" a second indicate number are used herein interchangeably and are meant to include the first and second indicated numbers and all the fractional and integral numerals therebetween.

[0124] As used herein the term "method" refers to manners, means, techniques and procedures for accomplishing a given task including, but not limited to, those manners, means, techniques and procedures either known to, or readily developed from known manners, means, techniques and procedures by practitioners of the chemical, pharmacological, biological, biochemical and medical arts.

[0125] As used herein, the term "treating" includes abrogating, substantially inhibiting, slowing or reversing the progression of a condition, substantially ameliorating clinical or aesthetical symptoms of a condition or substantially preventing the appearance of clinical or aesthetical symptoms of a condition.

[0126] It is appreciated that certain features of the invention, which are, for clarity, described in the context of separate embodiments, may also be provided in combination in a single embodiment. Conversely, various features of the invention, which are, for brevity, described in the context of a single embodiment, may also be provided separately or in any suitable subcombination or as suitable in any other described embodiment of the invention. Certain features described in the context of various embodiments are not to be considered essential features of those embodiments, without those elements.

[0127] Various embodiments and aspects of the present invention as delineated hereinabove and as claimed in the claims section below find experimental support in the following examples.

EXAMPLES

[0128] Reference is now made to the following example which, together with the above descriptions, illustrates some embodiments of the invention in a non-limiting fashion. It should be noted this example provides also features and parameter values which may be used with others of the embodiments described above.

[0129] The inventors conducted a study which included applying an embodiment of the method and the system for performing imaging *in vivo* and *in vitro* of vessels. Following are described the experimental set-up and the results obtained. It should be noted that the measurement and calculation methods described therein may be used with various exemplary embodiments of the invention or replaced by other methods.

Imaging system

[0130] Testing was conducted using the imaging system described in Figure 16.

In vivo imaging

[0131] A healthy volunteer (healthy male, age 32) was seated in a high chair with a padded chin rest and placed his lower lip against the imaging probe. Blood vessels at depths ranging from 70 μm to 200 μm under the tissue surface were located using the live view imaging of the green channel CCD. Each continuous imaging session was limited to less than 30 s, primarily due to subject motion.

In vitro imaging

[0132] Blood for *in vitro* imaging was extracted from healthy donors by venipuncture. 5000 units/ml Heparin (Fresenius) were added to prevent coagulation. Diluted whole blood (1:5) was prepared by adding phosphate buffered saline with 2% bovine serum albumin. Blood components were separated by density gradient centrifugation (lymphoprep™ Axis-shield). The mononuclear cell fraction was incubated for 1 hr at 37°C humidified incubator followed by collection of the non-adherent lymphocytes. Polymorphonuclear cells were purified by using an RBC lysis solution (Miltenyi Biotec). All WBCs were resuspended in autologous plasma which was diluted (1:1) with phosphate buffered saline. *In vitro* SEFC imaging of the different cell samples was performed at average flowing speed of 0.4 mm/s (Syringe pump 11 Elite, Harvard Apparatus) through a 5 mm \times 0.8 mm rectangular plastic flow chamber (μ slide-I, Ibidi). For standard fluorescence images, cell nuclei were stained with 1mg/ml Hoechst 33342 (Sigma Aldrich) and imaged using a 20 \times objective lens (Nikon).

Image and Data Analysis

[0133] The average flow velocity v_{av} was calculated according to:

$$v_{av} = d_{av} / t_{av},$$

where d_{av} denotes the average lateral size of the RBCs and t_{av} denotes their average passage time across the spectrally encoded line. Both d_{av} and t_{av} were calculated following manual segmentation of the cells in the raw image with a custom software (Matlab, Mathworks). The concentration of WBCs in a vessel was calculated according to:

$$C_{WBC} = N / (\pi R^2 v_{av} T),$$

where N denotes the total number of observed cells during a total imaging time T , and R denotes the estimated radius of the vessel. Assuming that cell detection follows Poisson statistics, the estimated error σ_{WBC} in determining the concentration is given by $\sigma_{WBC} = N^{1/2} / (\pi R^2 v_{av} T)$.

[0134] The fractional area occupied by RBCs in a single image was estimated by calculating the ratio between the total manually segmented cells area and the total vessel area (Photoshop CS3, Adobe).

Results

In vitro imaging

[0135] Scattering by flowing RBCs and a strong reflection from the glass surface of the flow chamber allowed imaging of whole blood at depths of less than 5 μm below the chamber wall. Clear images of flowing RBCs were obtained only after blood dilution which allowed significant improvement in image quality and depth (Fig. 17a). The nearly random orientation of RBCs in the flow of the diluted blood revealed a wide diversity of shapes and brightness levels in the SEFC images. RBCs which were oriented with their symmetry axis pointing toward the objective lens showed a few bright concentric rings with typical diameters of 6-8 μm , caused by interference of light reflections from the front and back plasma membranes (Fig. 17a, insets). Slanted and/or deformed RBCs appeared smaller and somewhat dimmer with various shapes including half circles, ellipses, and sharp curves.

[0136] WBCs appeared distinctively different from RBCs, with a larger size and a bright, speckled appearance. In order to study the appearance of different WBC subtypes in the SEFC image, granulocytes and lymphocytes were isolated from a whole blood sample, imaged within a flow chamber (Fig. 17b) and compared to fluorescently labeled wide-field images of cells from the same group. Granulocytes were characterized by a pronounced, high intensity speckled appearance and multi-lobed nuclei visible as darker regions within the cells, while lymphocytes were much fainter with a more uniform (although still speckled) appearance. These two cell populations, while overlapping in diameter (Fig. 17c) could be differentiated simply by plotting the integrated intensity and the measured size of each cell (Fig. 17d).

In vivo imaging

[0137] Micro vessels approximately 70 μm below the surface of the lower lip of a human volunteer were first located using the real-time green channel imager (Fig. 18a, inset). An SEFC image which was registered with the green image and captured from the location marked by a dashed red line in the inset, revealed a bright, dense population of blood cells as they crossed the spectral line. Three digital magnification steps (in the time axis only) of the raw image (Fig. 18a-d, top-to-bottom panels) reveal the shapes and geometries of individual flowing cells. Light scattered from the vessel walls and from the surrounding tissue formed constant horizontal streaks, indicative of the relatively fixed orientation of the probe with respect to the tissue during the measurement. A best balance between image quality and number of visible

cells was obtained 2-4 μm below the front vessel wall.

[0138] In several occasions, a better view of the cells could be gained by applying a slight pressure with the probe on the tissue, deforming the blood vessel into a flat oval shape and forcing the cells to align with their narrow dimension toward the flow direction (Fig. 19a). Using this technique, the average diameter of the RBCs was measured to be $6.6 \pm 0.7 \mu\text{m}$ (Fig. 19b), in agreement with *ex vivo* cell size measurements [V. Hoffbrand, P. Moss, and J. Pettit, Essential Hematology (Blackwell, Maiden, Mass., 2006)].

[0139] *In vivo* images (Figs. 18a-d and 19a) provide direct means for estimating the hematocrit level of a patient. This essential parameter could be calculated by measuring the fractional area occupied by RBCs in the raw image; in $n=6$ different vessels (see Fig. 19c for a typical vessel) with diameters ranging from 7 μm to 20 μm , the RBC fractional area was 0.47 ± 0.05 , which is in a good agreement with the expected hematocrit of an adult healthy male. Individual RBCs could also be visualized in smaller capillaries ($\sim 5-8 \mu\text{m}$ diameter), in which single-file flow enabled the identification and counting of practically all cells flowing through the vessel (Fig. 19d).

[0140] Identification of WBCs *in vivo* in view of their low concentration in healthy subjects may be assisted by using longer imaging periods for gaining sufficient data. For efficient detection of WBCs, the depth of focus of our imaging probe was positioned only a few microns below the front wall of post-capillary venules, where marginated WBCs are abundant [G. W. Schmid-Schonbein, S. Usami, R. Skalak, and S. Chien, "The interaction of leukocytes and erythrocytes in capillary and postcapillary vessels," *Microvascular Research* 19, 45-70 (1980)] and RBCs are rarely seen. In this location, passing WBCs could be detected and automatically registered by plotting the total scattered power as a function of time (Fig. 20a). The measurable WBC flux increases with vessel diameter, as shown by measuring the flux in $n=10$ different vessels (Fig. 20b). An average WBC diameter of $9.4 \pm 1.4 \mu\text{m}$ was measured (Fig. 20c), in agreement with our *in vitro* measurements. WBCs rolling on the endothelial vessel wall (Fig. 21A) and small aggregates of WBCs (Fig. 21B) were also observed on numerous occasions.

[0141] In small capillaries whose diameter is roughly that of a WBC, all passing WBCs could be easily viewed and counted. Most WBCs were viewed with a characteristic downstream RBC depleted region and an upstream accumulation of RBCs [G. W. Schmid-Schonbein, S. Usami, R. Skalak, and S. Chien, "The interaction of leukocytes and erythrocytes in capillary and postcapillary vessels," *Microvascular Research* 19, 45-70 (1980)] (Fig. 21C). A continuous 9.2 s long measurement across a 10 μm diameter capillary revealed a total of 12 cells, which correspond to a rough estimate of 8800 ± 2500 WBCs/ μL -within the normal range for healthy adults [V. Hoffbrand, P. Moss, and J. Pettit, Essential Hematology (Blackwell, Maiden, Mass., 2006)]. Longer measurement periods would significantly increase the accuracy of this

estimate, and may allow continuous tracking of WBC count in critical care patients which are sensitive to sudden inflammation. Although the invention has been described in conjunction with specific embodiments thereof, it is evident that many alternatives, modifications and variations will be apparent to those skilled in the art. Accordingly, it is intended to embrace all such alternatives, modifications and variations that fall within the broad scope of the appended claims.

Claims

1. A non-invasive method for locating a target blood vessel (116) and imaging particles flowing there-through, the method comprising:

illuminating from an imaging probe (1600) at least a first sub-region of a region (1628) including at least a portion of the target blood vessel (116) using a background light source (1620) providing a background light component having a substantially high susceptibility to absorption by particles (120) in said portion of the target blood vessel (116);

detecting backscattered background light from said illuminated sub-region;

reproducing at least one image from said backscattered background light;

identifying higher-absorbing regions within said reproduced image;

non-invasively moving the illumination to a second or further sub-region when no higher-absorbing region corresponding to said portion of the target blood vessel (116) is positioned along a focal line defined by a line-imaging illumination source of the imaging probe (1600);

iteratively applying said steps of illuminating, detecting, reproducing, identifying, and moving, until said higher-absorbing region is positioned along the focal line; and

imaging confocally along the focal line using light from the line-imaging illumination source;

characterized in that:

the line-imaging illumination source comprises a broadband illumination source (1602), and the light from the broadband illumination source (1602) comprises broadband light spectrally dispersed across the focal line such that light used to image from the focal line spectrally encodes position along the focal line; and
the illuminating by both the line-imaging illumination source and the background imaging source (1620) is from an objective lens (1612) and through an optically transparent surface of a cap (1629) of the imaging probe (1600), while

the transparent surface of the cap (1629) is pressed against a surface of the region (1628) to define a depth of imaging through the objective lens (1612) therein;

wherein said optically transparent surface is attached to said cap and wherein said illuminating is through said optically transparent surface.

2. The method of claim 1, wherein the moving comprises adjusting an imaging depth by movement of the optically transparent surface of the cap (1629) relative to the objective lens (1612).
3. The method of claim 1, wherein the background light component illuminates the sub-region after passage through a first polarizer (1623B) of a pair of crossed polarizers (1623A, 1623B), and the detecting is after the backscattered background light is passed through a second polarizer (1623A) of the pair of crossed polarizers (1623A, 1623B).
4. The method of claim 1 comprising detecting particles (120) flowing across the focal line.
5. The method of claim 1 wherein said broadband illumination source comprises a broad bandwidth light component or a wavelength-swept light component.
6. The method of claim 1 comprising determining a location, a speed of flow, a size, a length, a shape, a color, an orientation, a brightness of a particle, a number of particles (120), or any combination thereof, in said portion of said target blood vessel (116).
7. The method of any one of claims 1-6 wherein said target blood vessel (116) is a capillary, a venule or an arteriole.
8. The method of claim 7 wherein said background light component includes a green light.
9. The method of claim 7 wherein said target blood vessel (116) is located at a depth up to 100 μm below a tissue surface.
10. The method of claim 7 wherein said target blood vessel (116) is located at a depth of up to 200 μm below a tissue surface.
11. The method of claim 1, wherein said target blood vessel size comprises a diameter of between 1 μm and 50 μm .
12. The method of claim 1, wherein the imaging confocally comprises producing a cross-sectional 2D particle image wherein the focal line is sampled at a frequency above 10 KHz.

13. The method of claim 5, wherein said background light component has a shorter wavelength than the backscattered broadband light.

14. An imaging probe for locating a target blood vessel (116) and imaging particles (120) flowing there-through, the imaging probe comprising:

an objective lens (1612);
 a background imaging channel comprising a background light source (1620) and background light detector (1624), respectively configured to illuminate and image a tissue region (1628) through the objective lens (1612), using wide-field illumination comprising a background light component having a substantially high susceptibility to absorption by said particles (120); and a line-imaging channel comprising a line-imaging illumination source, and detection unit (1618), respectively configured to illuminate and image through the objective lens (1612) a focal line within the tissue region (1628);

characterized in that:

the line-imaging illumination source comprises a broadband illumination source (1602) coupled to a dispersing element (1608) to spectrally disperse broadband light (912) along the focal line;

the line-imaging channel also comprises a collimator (1613, 1614) configured to direct light backscattered from the focal line to the detection unit (1618);

the detection unit (1618) comprises a spectrometer (1618), configured to spectrally decode position from light (913) returning from the focal line; and

the background imaging channel and the line-imaging channel both illuminate from the objective lens (1612) through an optically transparent surface of a cap (1629) of the imaging probe (1600);

wherein the optically transparent surface is spaced from the objective lens (1612), to define a depth of imaging of the background imaging channel and the line-imaging channel when the cap (1629) is pressed against a surface of the tissue region (1628); and wherein said optically transparent surface is attached to said cap and wherein said illuminating is through said optically transparent surface.

15. The imaging probe of claim 14, comprising a first polarizer and a second polarizer of a pair of crossed polarizers (1623A, 1623B), positioned so that light from the background light source (1620) illuminates the tissue region (1628) after passage through the

first polarizer (1623B) and the background light detector detects backscattered background light after passage through the second polarizer (1623A).

Patentansprüche

1. Nichtinvasives Verfahren zum Lokalisieren eines Zielblutgefäßes (116) und Abbilden von durchfließenden Partikeln, wobei das Verfahren umfasst:

von einer Bildgebungssonde (1600) Beleuchten mindestens eines ersten Teilbereichs eines Bereichs (1628), der mindestens einen Abschnitt des Zielblutgefäßes (116) umfasst, unter Verwendung einer Hintergrundlichtquelle (1620), die eine Hintergrundlichtkomponente bereitstellt, die eine im Wesentlichen hohe Empfindlichkeit für die Absorption durch Partikel (120) in dem Abschnitt des Zielblutgefäßes (116) aufweist;

Erfassen von rückgestreutem Hintergrundlicht aus dem beleuchteten Teilbereich;

Wiedergeben mindestens eines Bildes aus dem rückgestreuten Hintergrundlicht;

Erkennen von Bereichen mit höherer Absorption innerhalb des wiedergegebenen Bildes;

nichtinvasives Bewegen der Beleuchtung zu einem zweiten oder weiteren Teilbereich, wenn kein stärker absorbierender Bereich, der dem Abschnitt des Zielblutgefäßes (116) entspricht, entlang einer durch eine linienabbildende Beleuchtungsquelle der Bildgebungssonde (1600) definierten Brennlinie positioniert ist;

iteratives Anwenden der Schritte des Beleuchtens, Erfassens, Wiedergebens, Erkennens und Bewegen, bis der stärker absorbierende Bereich entlang der Brennlinie positioniert ist; und konfokales Abbilden entlang der Brennlinie unter Verwendung von Licht von der linienabbildenden Beleuchtungsquelle;

dadurch gekennzeichnet, dass:

die linienabbildende Beleuchtungsquelle eine breitbandige Beleuchtungsquelle (1602) umfasst und das Licht von der breitbandigen Beleuchtungsquelle (1602) breitbandiges Licht umfasst, das spektral über die Brennlinie verteilt ist, sodass Licht, das zum Abbilden von der Brennlinie verwendet wird, die Position entlang der Brennlinie spektral codiert; und die Beleuchtung sowohl durch die linienabbildende Beleuchtungsquelle als auch die Hintergrundabbildungsquelle (1620) von einer Objektivlinse (1612) und durch eine optisch transparente Oberfläche einer Kappe (1629) der Bildgebungssonde (1600) erfolgt, während die

- transparente Oberfläche der Kappe (1629) gegen eine Oberfläche des Bereichs (1628) gedrückt wird, um darin eine Tiefe der Bildgebung durch die Objektivlinse (1612) zu definieren;
- wobei die optisch transparente Oberfläche an der Kappe befestigt ist und wobei die Beleuchtung durch die optisch transparente Oberfläche erfolgt.
2. Verfahren nach Anspruch 1, wobei das Bewegen ein Einstellen einer Bildgebungstiefe durch Bewegung der optisch transparenten Oberfläche der Kappe (1629) relativ zur Objektivlinse (1612) umfasst.
3. Verfahren nach Anspruch 1, wobei die Hintergrundlichtkomponente den Teilbereich nach dem Durchgang durch einen ersten Polarisator (1623B) eines Paares gekreuzter Polarisatoren (1623A, 1623B) beleuchtet und die Erfassung erfolgt, nachdem das rückgestreute Hintergrundlicht durch einen zweiten Polarisator (1623A) des Paares gekreuzter Polarisatoren (1623A, 1623B) geleitet wurde.
4. Verfahren nach Anspruch 1, umfassend das Erfassen von über die Brennlänge strömenden Partikeln (120).
5. Verfahren nach Anspruch 1, wobei die breitbandige Beleuchtungsquelle eine breitbandige Lichtkomponente oder eine wellenlängengewobbelte Lichtkomponente umfasst.
6. Verfahren nach Anspruch 1, umfassend das Ermitteln eines Ortes, einer Strömungsgeschwindigkeit, einer Größe, einer Länge, einer Form, einer Farbe, einer Ausrichtung, einer Helligkeit eines Partikels, einer Anzahl von Partikeln (120) oder einer Kombination davon in dem Abschnitt des Zielblutgefäßes (116).
7. Verfahren nach einem der Ansprüche 1 bis 6, wobei das Zielblutgefäß (116) eine Kapillare, eine Venole oder eine Arteriole ist.
8. Verfahren nach Anspruch 7, wobei die Hintergrundlichtkomponente grünes Licht beinhaltet.
9. Verfahren nach Anspruch 7, wobei sich das Zielblutgefäß (116) in einer Tiefe von bis zu 100 μm unterhalb einer Gewebeoberfläche befindet.
10. Verfahren nach Anspruch 7, wobei sich das Zielblutgefäß (116) in einer Tiefe von bis zu 200 μm unterhalb einer Gewebeoberfläche befindet.
11. Verfahren nach Anspruch 1, wobei die Zielblutgefäßgröße einen Durchmesser zwischen 1 μm und 50 μm umfasst.
12. Verfahren nach Anspruch 1, wobei das konfokale Abbilden das Erzeugen eines 2-D-Querschnittspartikelbildes umfasst, wobei die Brennlänge mit einer Frequenz oberhalb von 10 kHz abgetastet wird.
13. Verfahren nach Anspruch 5, wobei die Hintergrundlichtkomponente eine kürzere Wellenlänge als das rückgestreute Breitbandlicht aufweist.
14. Bildgebungssonde zum Lokalisieren eines Zielblutgefäßes (116) und von Bildgebungspartikeln (120), die durch dieses strömen, wobei die Bildgebungssonde umfasst:
- eine Objektivlinse (1612);
einen Hintergrundabbildungskanal, der eine Hintergrundlichtquelle (1620) und einen Hintergrundlichtdetektor (1624) umfasst, die jeweils konfiguriert sind, um einen Gewebebereich (1628) zu beleuchten und durch die Objektivlinse (1612) abzubilden, wobei eine Weitfeldbeleuchtung verwendet wird, die eine Hintergrundlichtkomponente umfasst, die eine im Wesentlichen hohe Empfindlichkeit für die Absorption durch die Partikel (120) aufweist; und
einen Linienabbildungskanal, der eine Linienabbildungsbeleuchtungsquelle und eine Erfassungseinheit (1618) umfasst, die jeweils konfiguriert sind, um eine Brennlänge innerhalb des Gewebebereichs (1628) durch die Objektivlinse (1612) zu beleuchten und abzubilden;
- dadurch gekennzeichnet, dass:**
- die linienabbildende Beleuchtungsquelle eine breitbandige Beleuchtungsquelle (1602) umfasst, die mit einem Dispersionselement (1608) verbunden ist, um breitbandiges Licht (912) entlang der Brennlänge spektral zu dispergieren;
der Linienabbildungskanal außerdem einen Kollimator (1613, 1614) umfasst, der konfiguriert ist, um von der Brennlänge zurückgestreutes Licht auf die Erfassungseinheit (1618) zu richten;
die Erfassungseinheit (1618) ein Spektrometer (1618) umfasst, das konfiguriert ist, um die Position von Licht (913), das von der Brennlänge zurückkehrt, spektral zu decodieren; und
der Hintergrundabbildungskanal und der Linienabbildungskanal beide von der Objektivlinse (1612) durch eine optisch transparente Oberfläche einer Kappe (1629) der Bildgebungssonde (1600) beleuchten;
wobei die optisch transparente Oberfläche in einem Abstand von der Objektivlinse (1612) angeordnet ist, um eine Bildgebungstiefe des Hintergrundabbildungskanals und des Linienabbildungskanals zu definieren, wenn die Kappe

(1629) gegen eine Oberfläche des Gewebebereichs (1628) gedrückt wird; und wobei die optisch transparente Oberfläche an der Kappe befestigt ist und wobei die Beleuchtung durch die optisch transparente Oberfläche erfolgt.

15. Bildgebungssonde nach Anspruch 14, umfassend einen ersten Polarisator und einen zweiten Polarisator eines Paares gekreuzter Polarisatoren (1623A, 1623B), die so positioniert sind, dass Licht von der Hintergrundlichtquelle (1620) den Gewebebereich (1628) nach dem Durchgang durch den ersten Lichtpolarisator (1623B) beleuchtet und der Hintergrundlichtdetektor rückgestreutes Hintergrundlicht nach dem Durchgang durch den zweiten Polarisator (1623A) erkennt.

Revendications

1. Méthode non invasive de localisation d'un vaisseau sanguin cible (116) et d'imagerie de particules le traversant, la méthode comprenant :

éclairer à partir d'une sonde d'imagerie (1600) au moins une première sous-région d'une région (1628) comprenant au moins une partie du vaisseau sanguin cible (116) à l'aide d'une source de lumière de fond (1620) fournissant un composant d'éclairage de fond présentant une susceptibilité d'absorption sensiblement élevée par des particules (120) dans ladite partie du vaisseau sanguin cible (116) ;
détecter une lumière de fond rétrodiffusée provenant de ladite sous-région éclairée ;
reproduire au moins une image à partir de ladite lumière de fond rétrodiffusée ;
identifier des régions plus absorbantes à l'intérieur de ladite image reproduite ;
déplacer de façon non invasive l'éclairage vers une deuxième ou une autre sous-région lorsqu'aucune région plus absorbante correspondant à ladite partie du vaisseau sanguin cible (116) n'est positionnée le long d'une ligne focale définie par une source d'éclairage d'imagerie linéaire de la sonde d'imagerie (1600) ;
appliquer de manière itérative lesdites étapes consistant à éclairer, détecter, reproduire, identifier et déplacer jusqu'à ce que ladite région plus absorbante soit positionnée le long de la ligne focale ; et
former une image confocale le long de la ligne focale en utilisant la lumière provenant de la source d'éclairage d'imagerie linéaire ;

caractérisée en ce que :

la source d'éclairage d'imagerie linéaire comprend une source d'éclairage à large bande (1602) et la lumière provenant de la source d'éclairage à large bande (1602) comprend une lumière à large bande dispersée spectralement sur la ligne focale de sorte que la lumière utilisée pour imager à partir de la ligne focale code de manière spectrale la position le long de la ligne focale ; et

l'éclairage à la fois par la source d'éclairage d'imagerie linéaire et par la source d'imagerie de fond (1620) provient d'une lentille de focalisation (1612) et à travers une surface optiquement transparente d'un capuchon (1629) de la sonde d'imagerie (1600), tandis que la surface transparente du capuchon (1629) est pressée contre une surface de la région (1628) pour définir une profondeur de formation d'image à travers la lentille de focalisation (1612) à l'intérieur de celle-ci ;

dans laquelle ladite surface optiquement transparente est fixée audit capuchon et dans laquelle ledit éclairage traverse ladite surface optiquement transparente.

2. Méthode selon la revendication 1, dans laquelle le déplacement comprend le réglage d'une profondeur d'imagerie par déplacement de la surface optiquement transparente du capuchon (1629) par rapport à la lentille de focalisation (1612).
3. Méthode selon la revendication 1, dans laquelle le composant de lumière de fond éclaire la sous-région après le passage à travers un premier polariseur (1623B) d'une paire de polariseurs croisés (1623A, 1623B) et la détection a lieu après le passage de la lumière de fond rétrodiffusée à travers un second polariseur (1623A) de la paire de polariseurs croisés (1623A, 1623B).
4. Méthode selon la revendication 1, comprenant la détection de particules (120) traversant la ligne focale.
5. Méthode selon la revendication 1, dans laquelle ladite source d'éclairage à large bande comprend un composant de lumière à large bande ou un composant de lumière à balayage de longueur d'onde.
6. Méthode selon la revendication 1, consistant à déterminer un emplacement, une vitesse d'écoulement, une taille, une longueur, une forme, une couleur, une orientation, une luminosité d'une particule, un nombre de particules (120) ou toute combinaison de ceux-ci, dans ladite partie dudit vaisseau sanguin cible (116).
7. Méthode selon l'une quelconque des revendications

- 1 à 6, dans laquelle ledit vaisseau sanguin cible (116) est un capillaire, une veinule ou un artériole.
8. Méthode selon la revendication 7, dans laquelle ledit composant de lumière de fond comprend une lumière verte. 5
9. Méthode selon la revendication 7, dans laquelle ledit vaisseau sanguin cible (116) est situé à une profondeur allant jusqu'à 100 μm sous la surface d'un tissu. 10
10. Méthode selon la revendication 7, dans laquelle ledit vaisseau sanguin cible (116) est situé à une profondeur allant jusqu'à 200 μm sous la surface d'un tissu. 15
11. Méthode selon la revendication 1, dans laquelle ladite taille de vaisseau sanguin cible comprend un diamètre compris entre 1 μm et 50 μm .
12. Méthode selon la revendication 1, dans laquelle la formation d'image confocale comprend la production d'une image de particule 2D en coupe transversale dans laquelle la ligne focale est échantillonnée à une fréquence supérieure à 10 KHz. 20
13. Méthode selon la revendication 5, dans laquelle ledit composant de lumière de fond a une longueur d'onde plus courte que la lumière à large bande rétrodiffusée. 25
14. Sonde d'imagerie pour localiser un vaisseau sanguin cible (116) et des particules d'imagerie (120) le traversant, la sonde d'imagerie comprenant : 30
- une lentille de focalisation (1612) ; 35
 - un canal d'imagerie de fond comprenant une source de lumière de fond (1620) et un détecteur de lumière de fond (1624), respectivement configurés pour éclairer et imager une région de tissu (1628) à travers la lentille de focalisation (1612), en utilisant un éclairage à champ large comprenant un composant de lumière de fond présentant une susceptibilité d'absorption par lesdites particules (120) sensiblement élevée ; 40
 - et 45
 - un canal d'imagerie linéaire comprenant une source d'éclairage d'imagerie linéaire et une unité de détection (1618), respectivement configurés pour éclairer et imager à travers la lentille de focalisation (1612) une ligne focale dans la région tissulaire (1628) ; 50
- caractérisée en ce que :**
- la source d'éclairage d'imagerie linéaire comprend une source d'éclairage à large bande (1602) couplée à un élément de dispersion (1608) pour disperser spectralement une lumière à large bande (912) le long de la ligne focale ; le canal d'imagerie linéaire comprend également un collimateur (1613, 1614) configuré pour diriger la lumière rétrodiffusée de la ligne focale vers l'unité de détection (1618) ; l'unité de détection (1618) comprend un spectromètre (1618), configuré pour décoder spectralement la position à partir de la lumière (913) revenant de la ligne focale ; et le canal d'imagerie de fond et le canal d'imagerie linéaire éclairent tous deux à partir de la lentille de focalisation (1612) à travers une surface optiquement transparente d'un capuchon (1629) de la sonde d'imagerie (1600) ; dans laquelle la surface optiquement transparente est espacée de la lentille de focalisation (1612), pour définir une profondeur de formation d'image du canal d'imagerie de fond et du canal d'imagerie linéaire lorsque le capuchon (1629) est pressé contre une surface de la région tissulaire (1628) ; et dans laquelle ladite surface optiquement transparente est fixée audit capuchon et dans laquelle ledit éclairage traverse ladite surface optiquement transparente. 55
15. Sonde d'imagerie selon la revendication 14, comprenant un premier polariseur et un second polariseur d'une paire de polariseurs croisés (1623A, 1623B), positionnés de sorte que la lumière provenant de la source de lumière de fond (1620) éclaire la région tissulaire (1628) après son passage à travers le premier polariseur (1623B) et le détecteur de lumière de fond détecte la lumière de fond rétrodiffusée après son passage à travers le second polariseur (1623A).

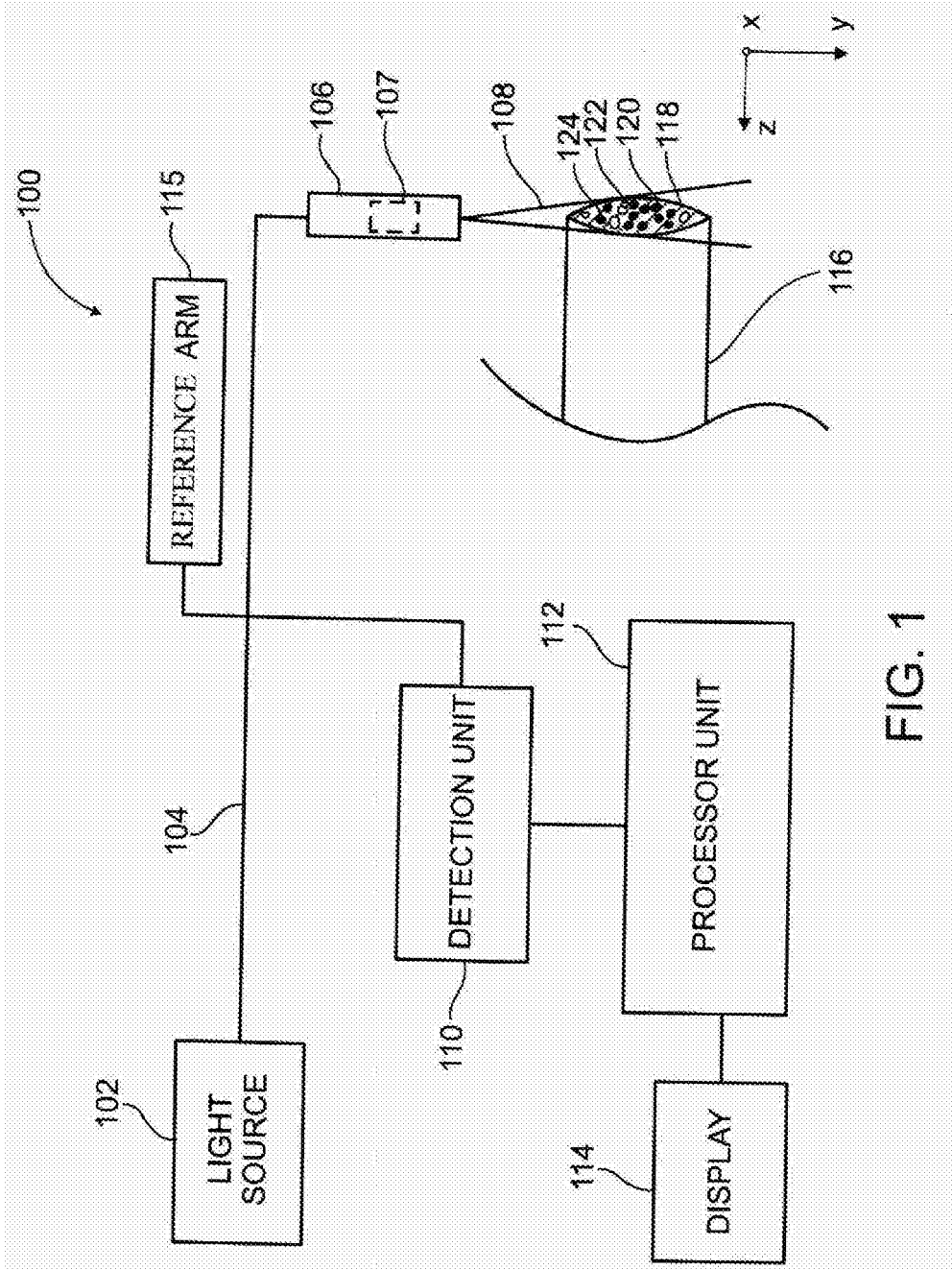

FIG. 1

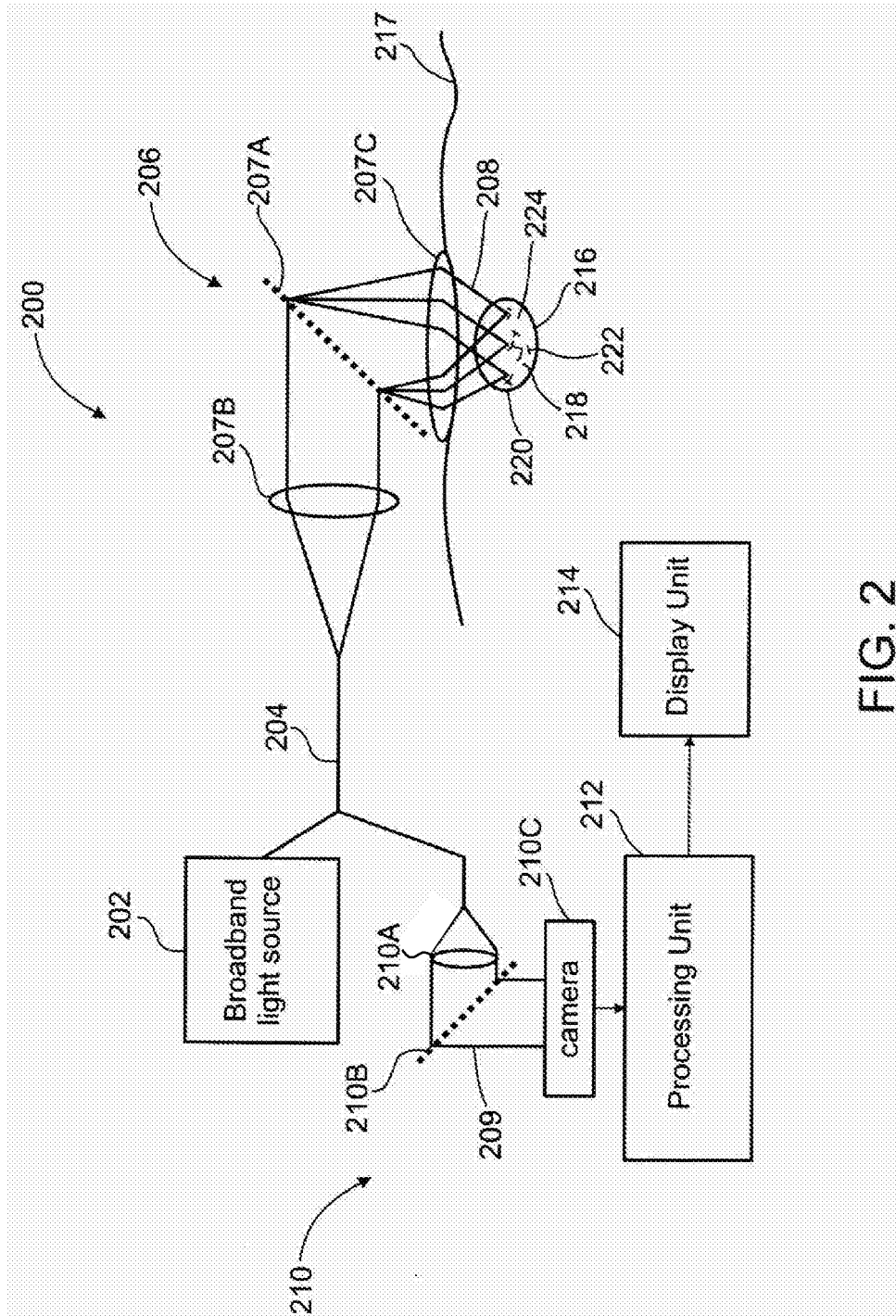

FIG. 2

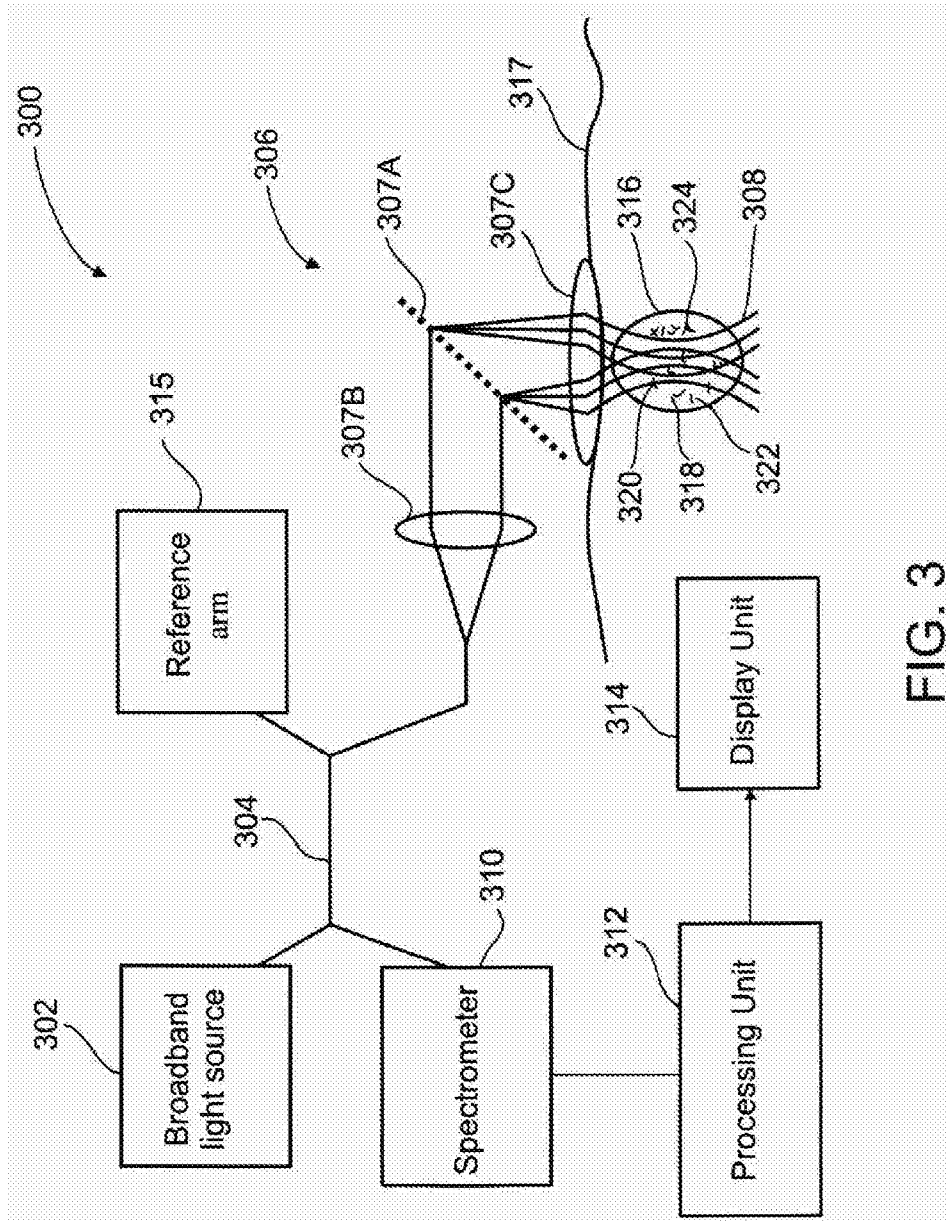

FIG. 3

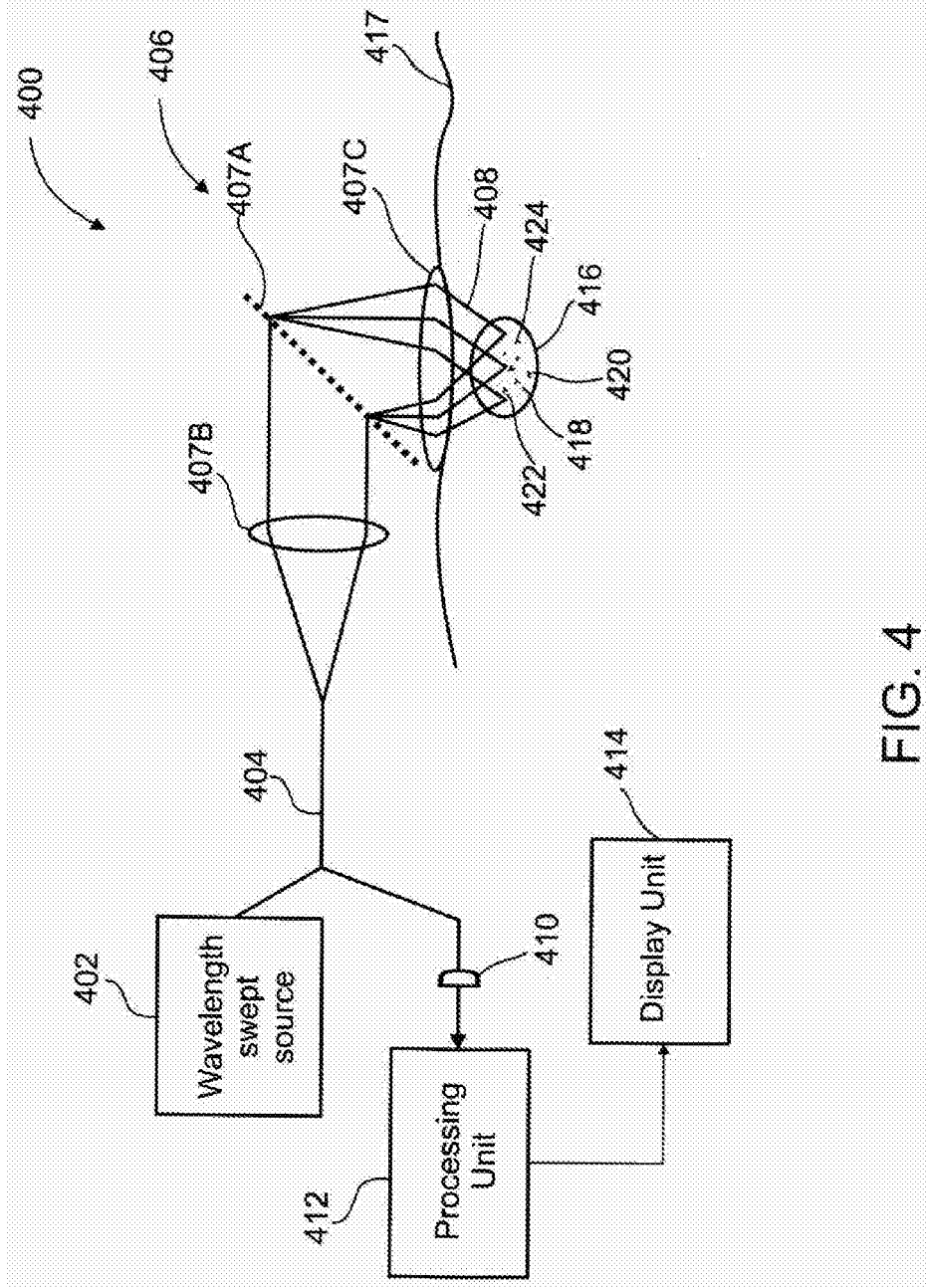

FIG. 4

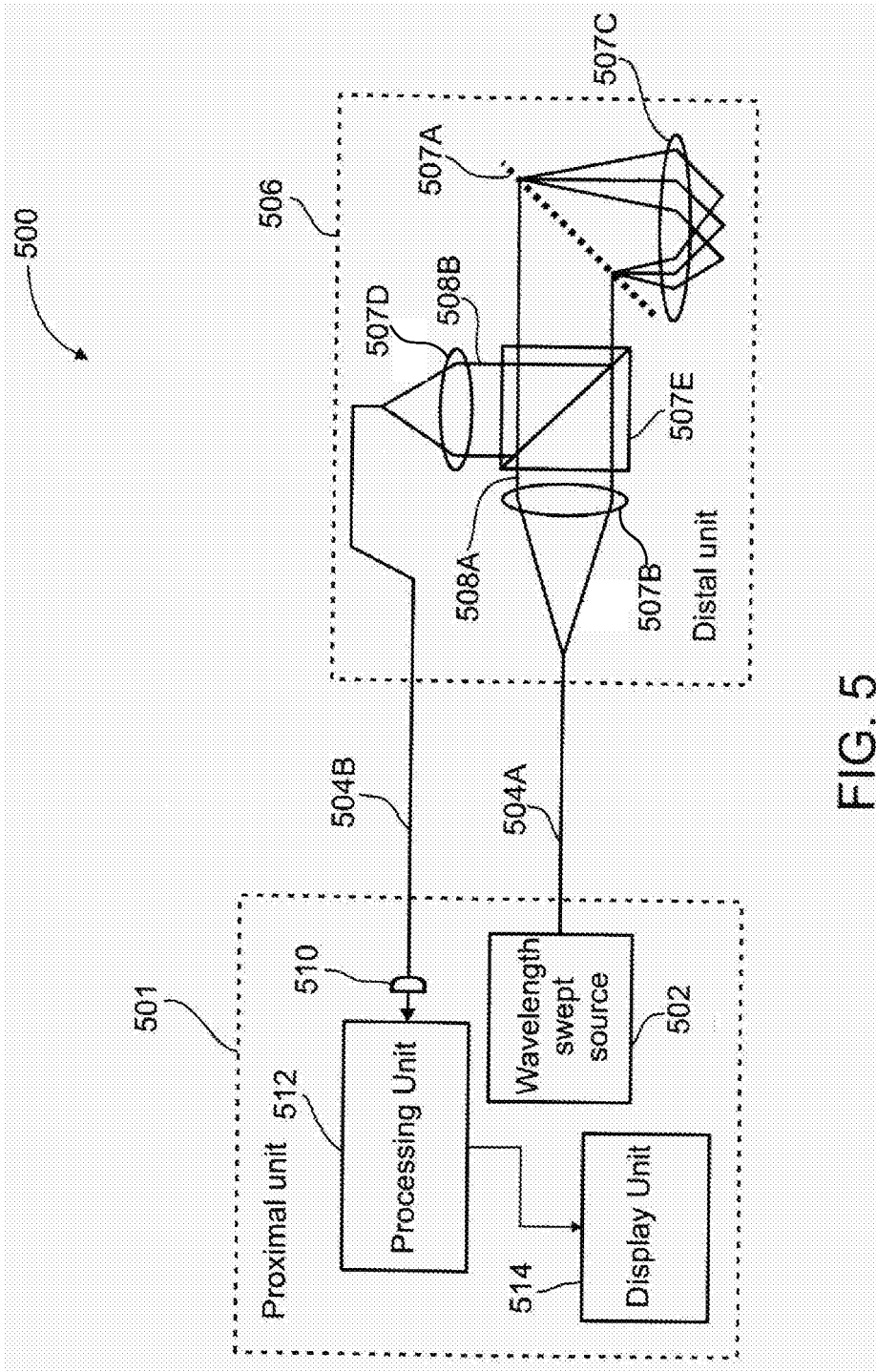

FIG. 5

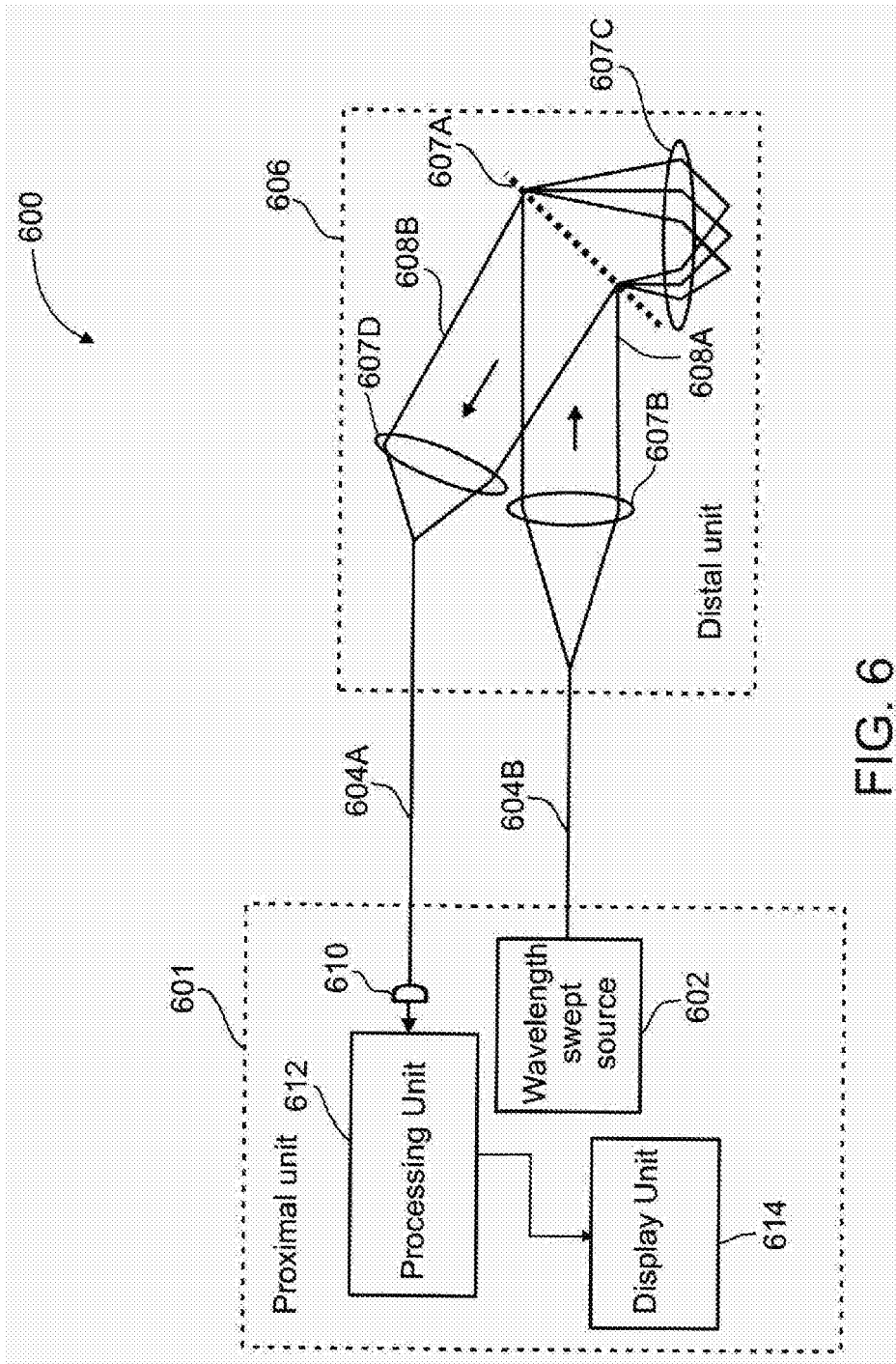

FIG. 6

Single measurement:
event, signal, single particle

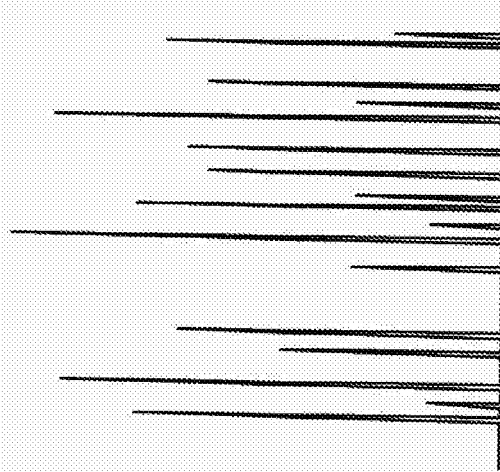

FIG. 7A

Cross-sectional imaging:
size, shape, location, many particles

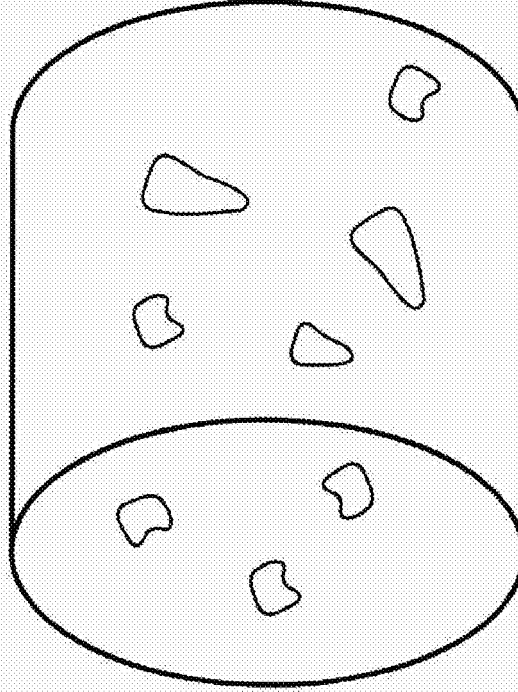

FIG. 7B

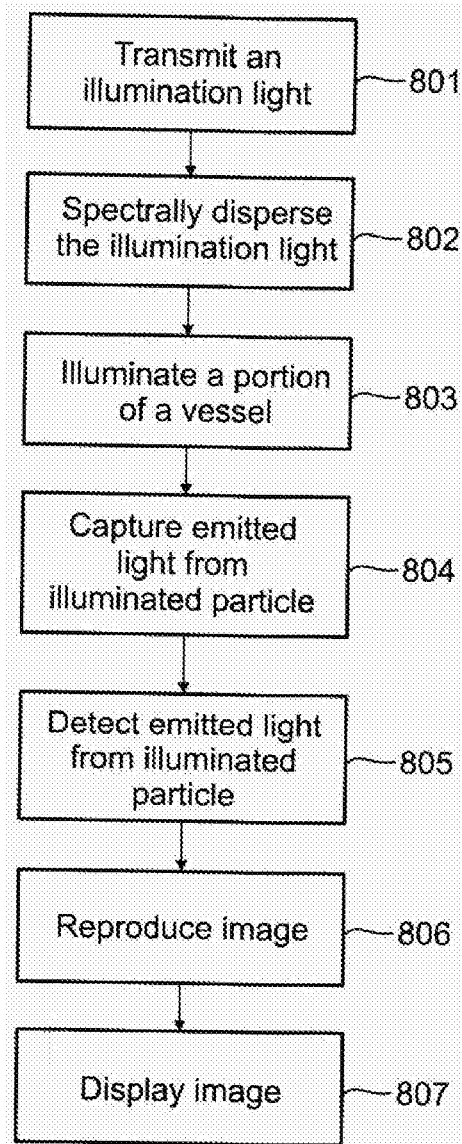

FIG. 8A

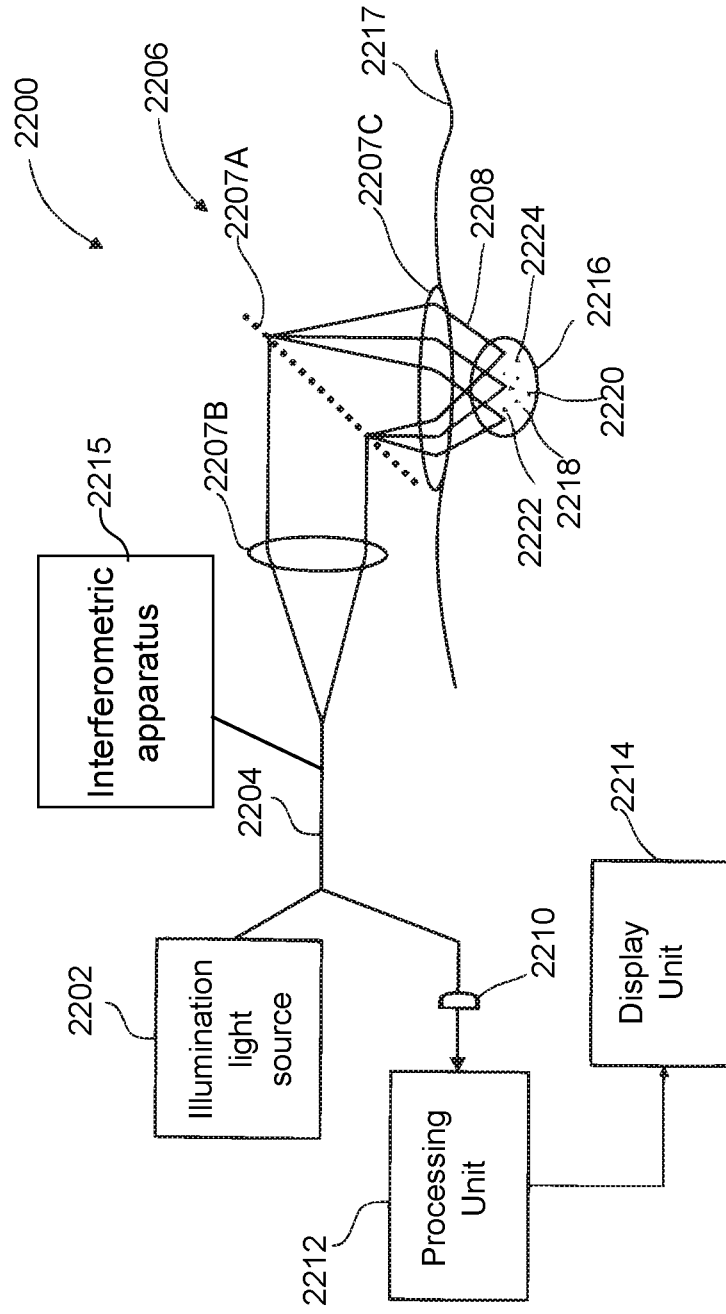

FIG. 8B

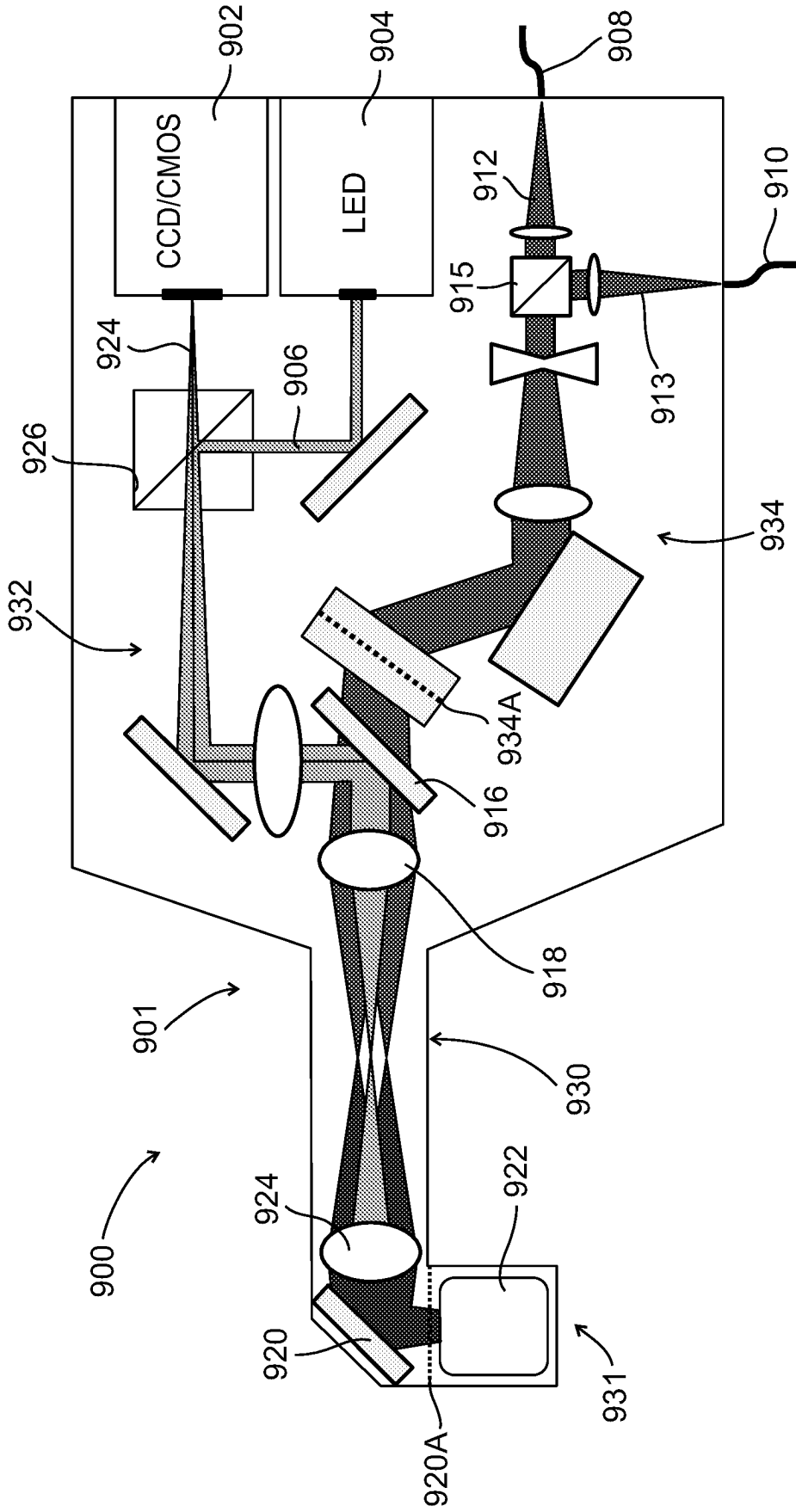

FIG. 9

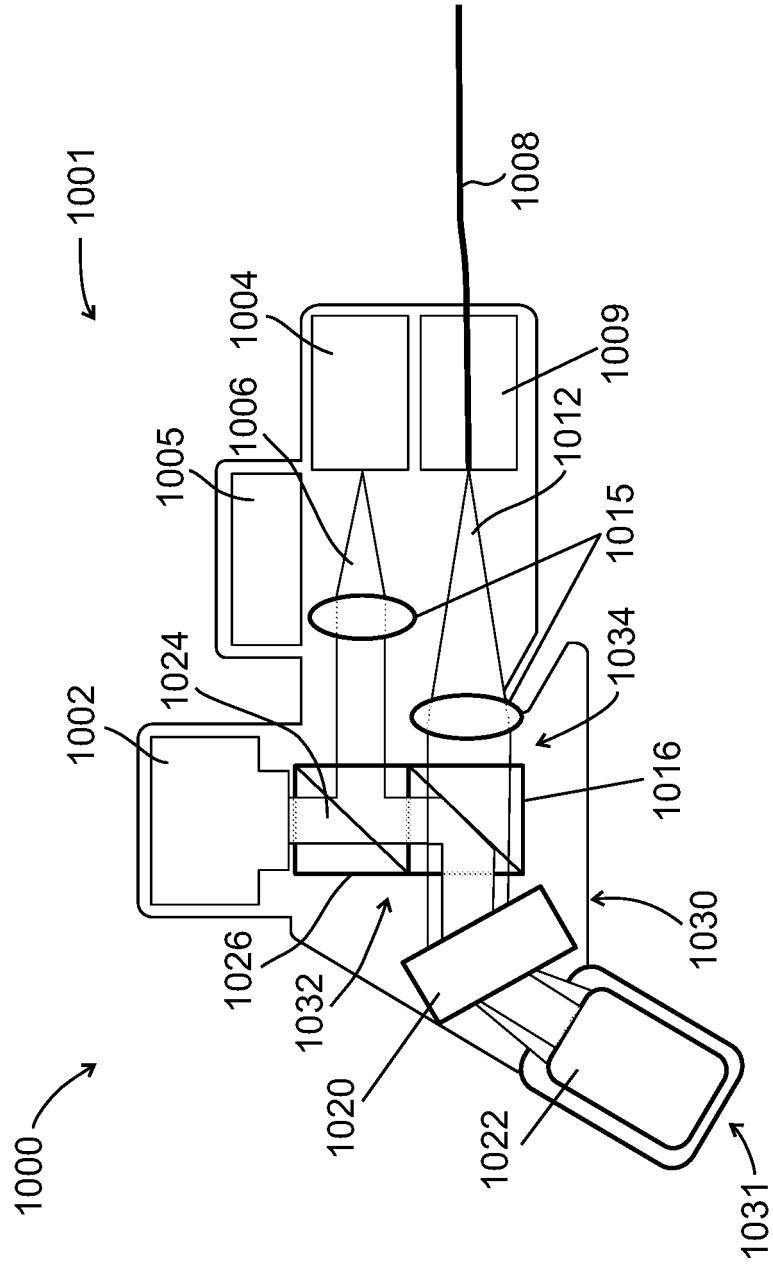

FIG. 10

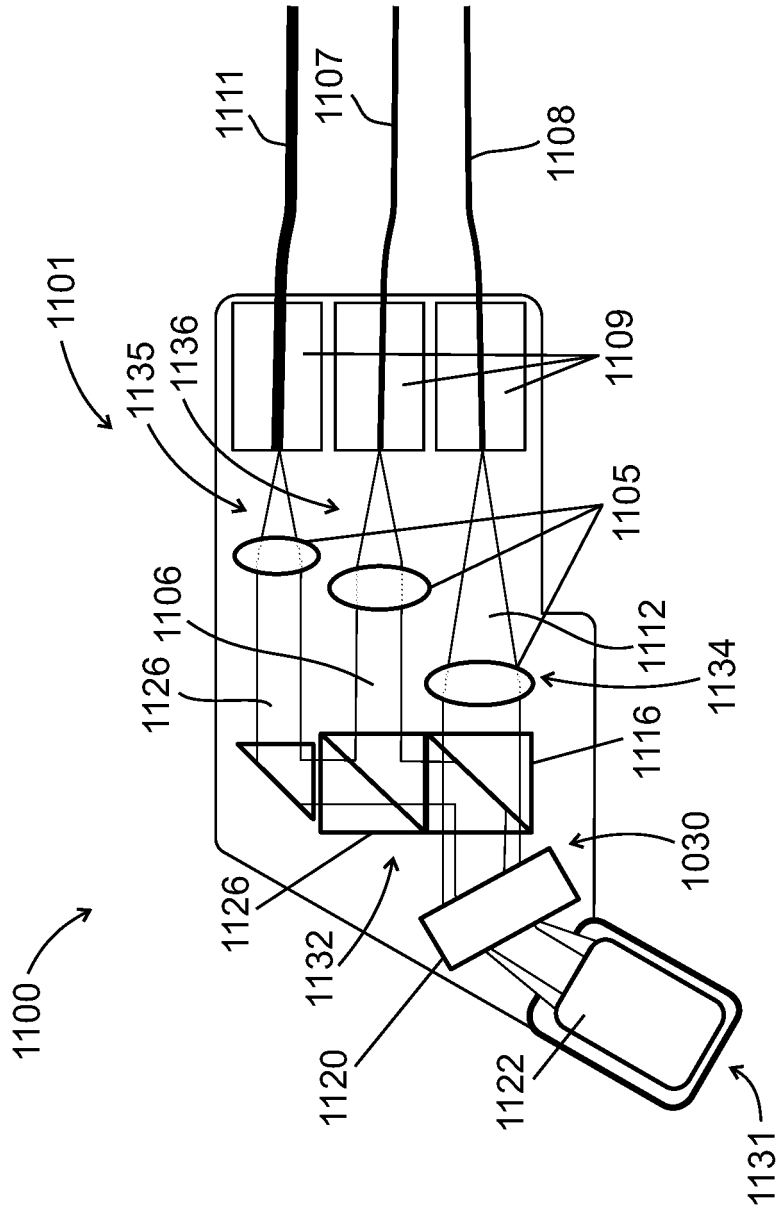

FIG. 11

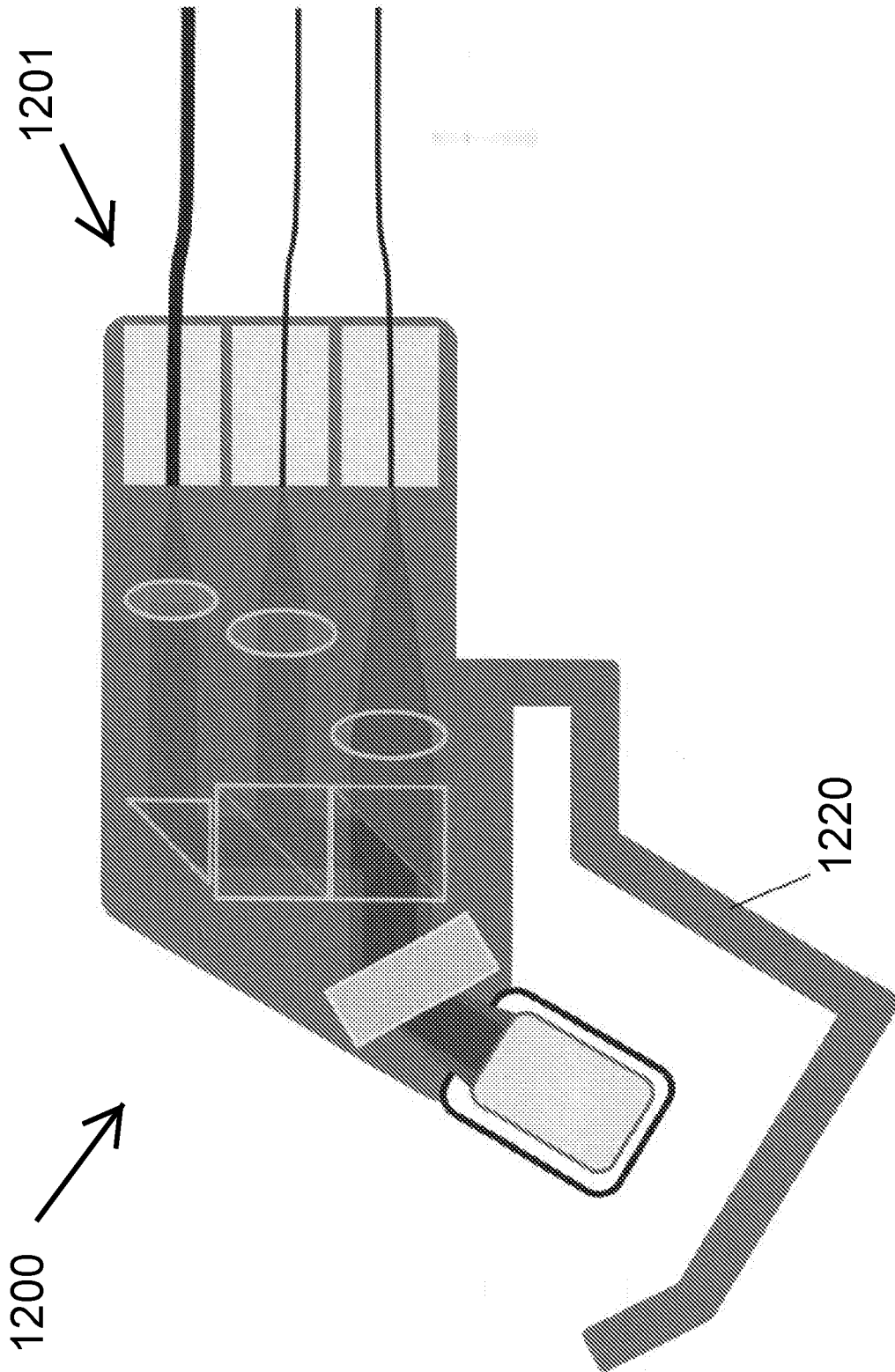

FIG. 12

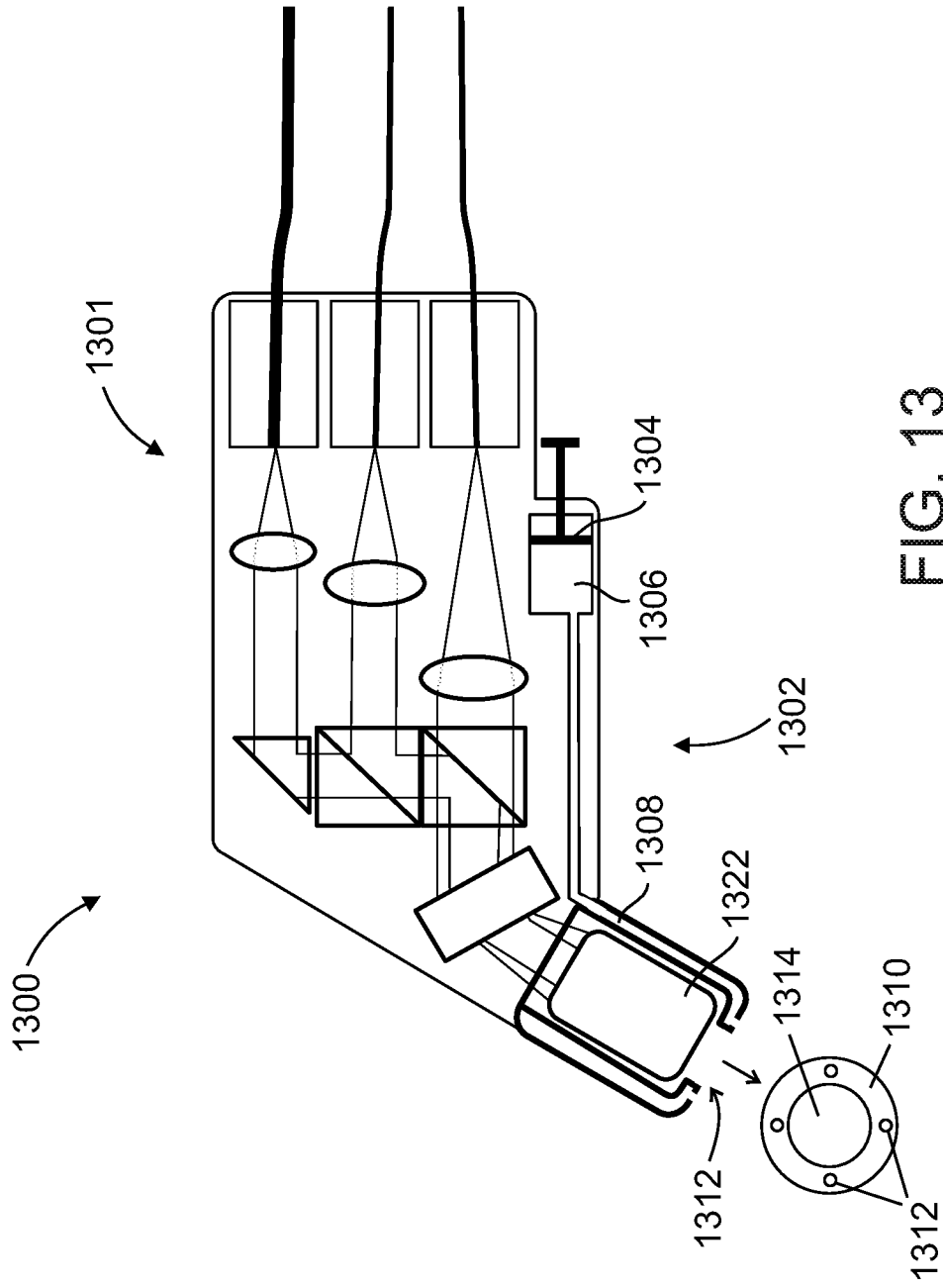

FIG. 13

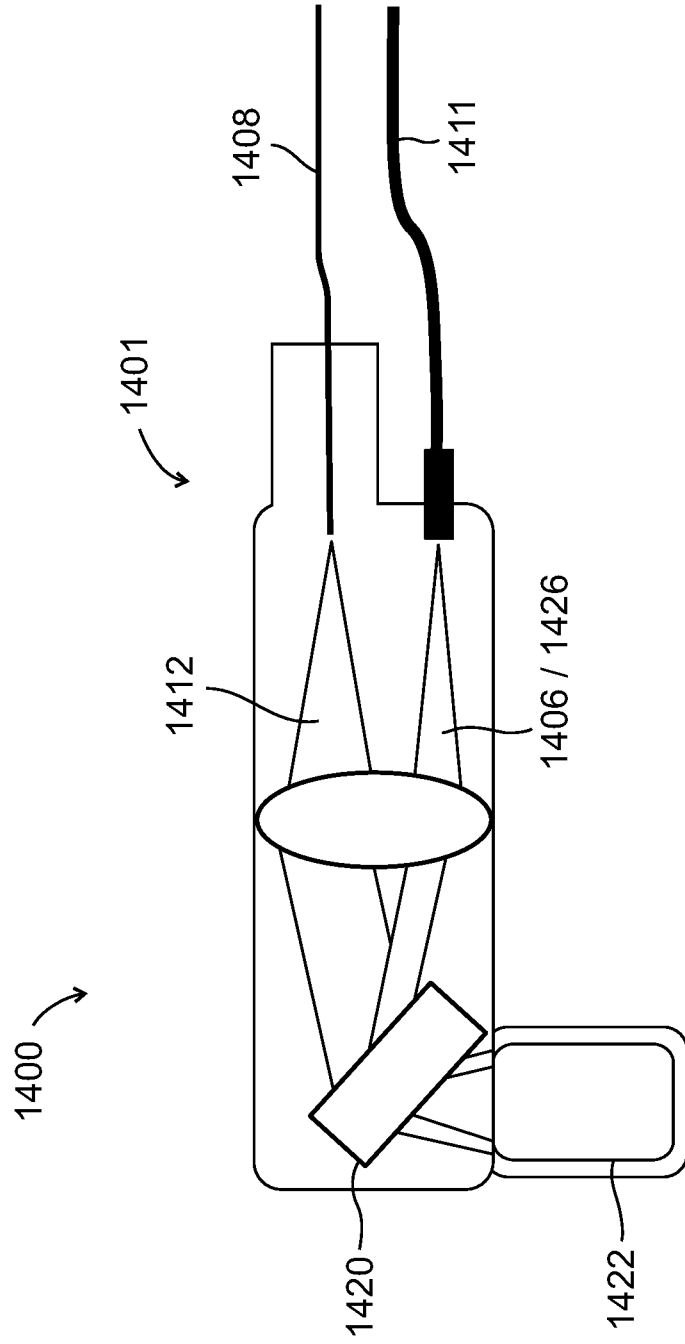

FIG. 14

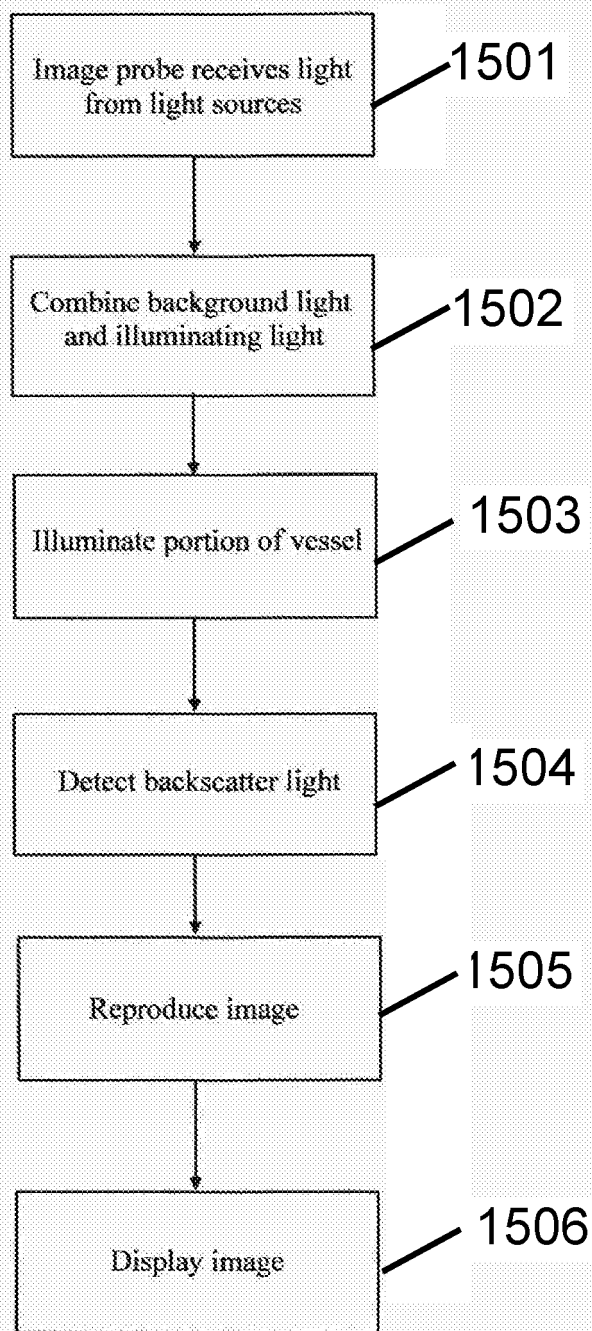

FIG. 15

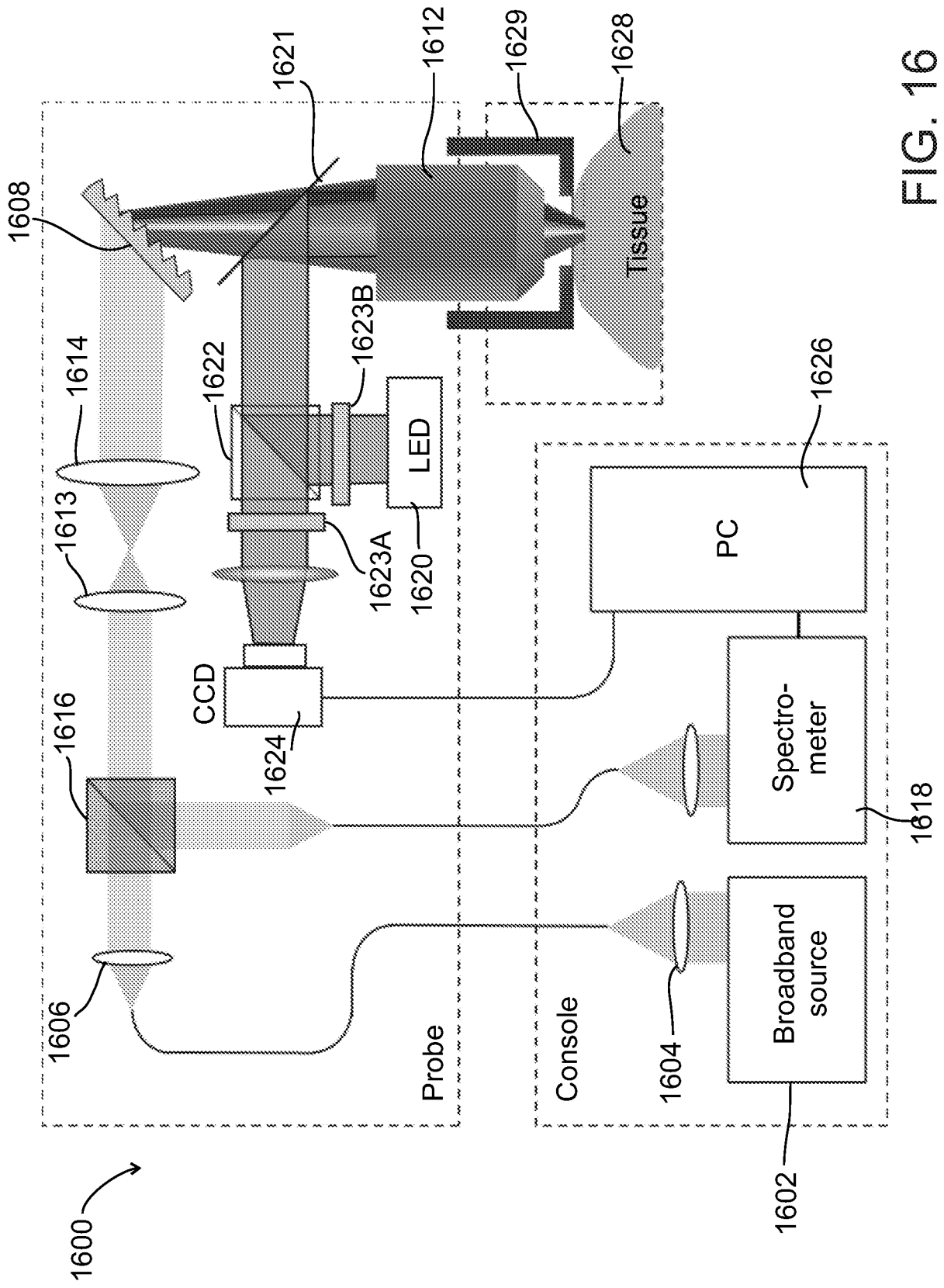

FIG. 16

FIG.17A

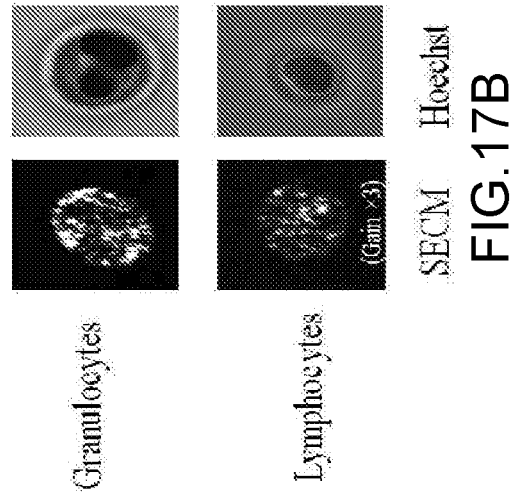
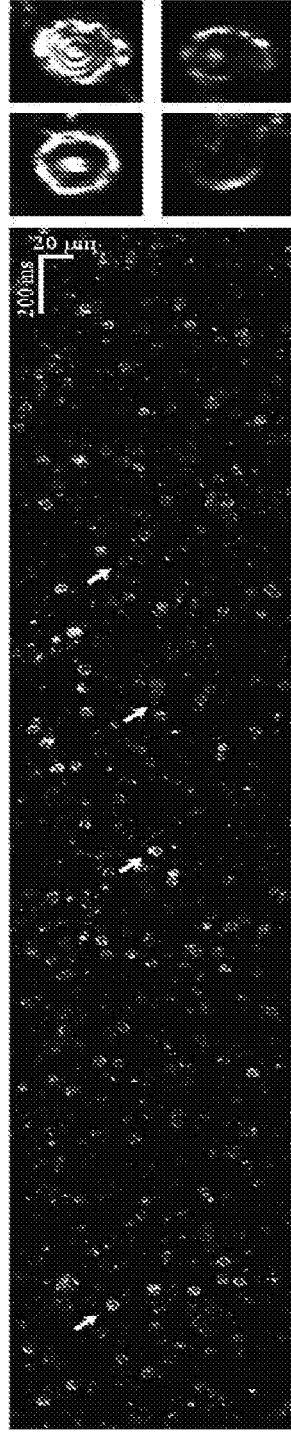

FIG.17B

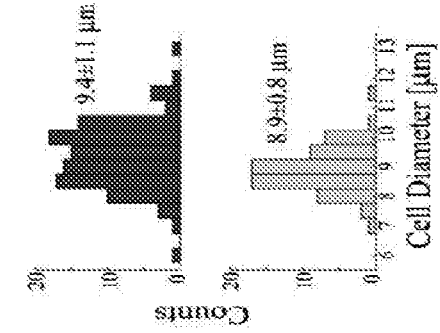

FIG.17C

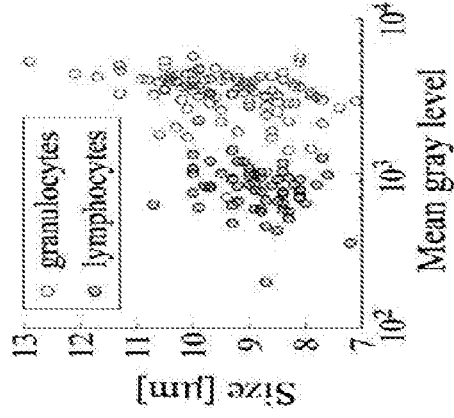

FIG.17D

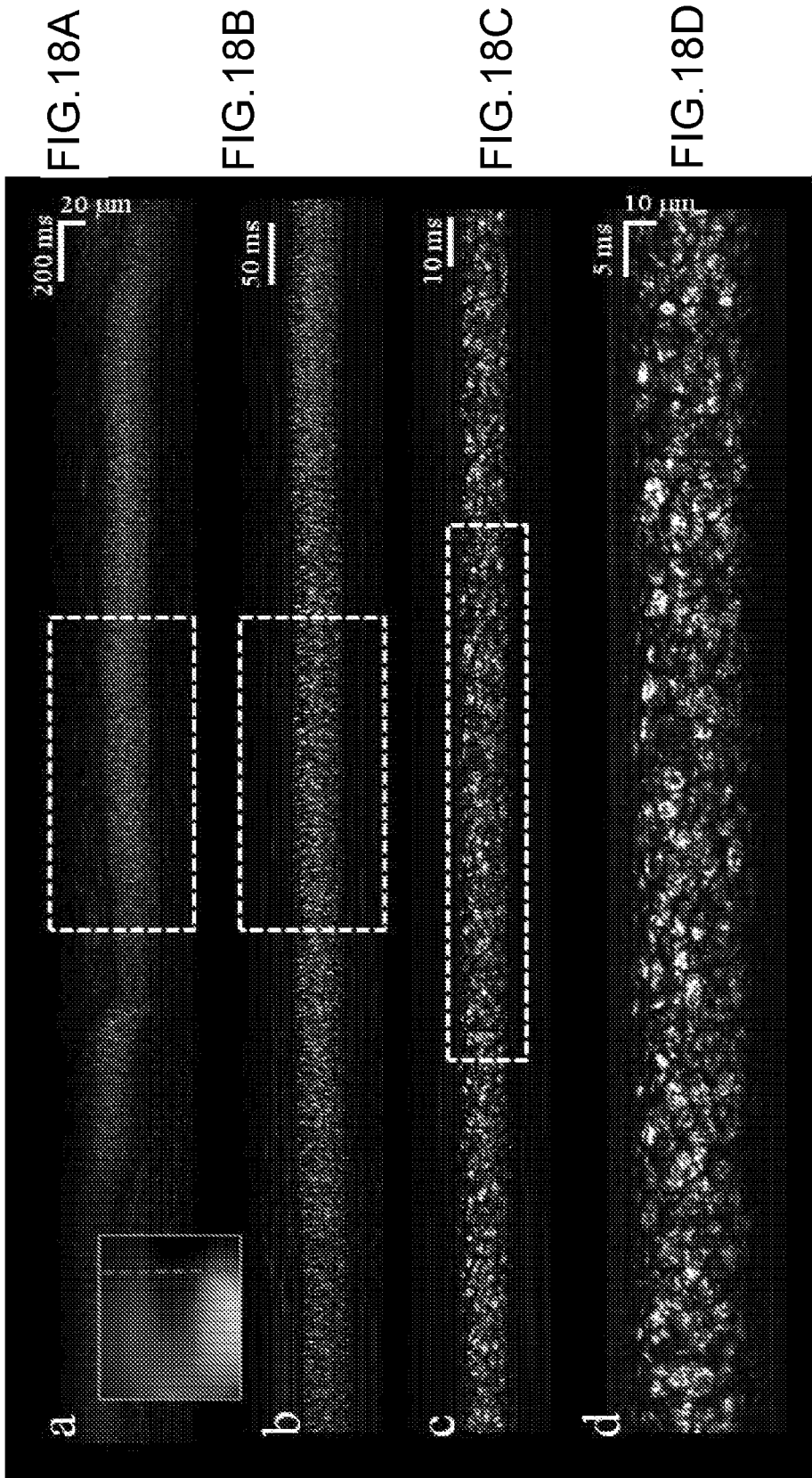

FIG. 19A



FIG. 19B

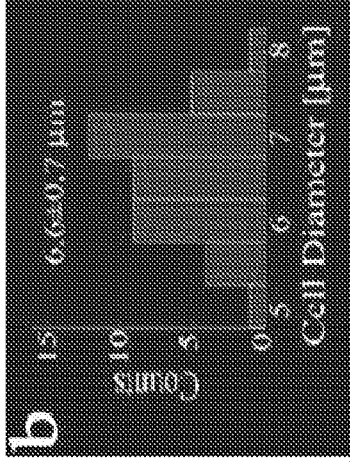

FIG. 19C

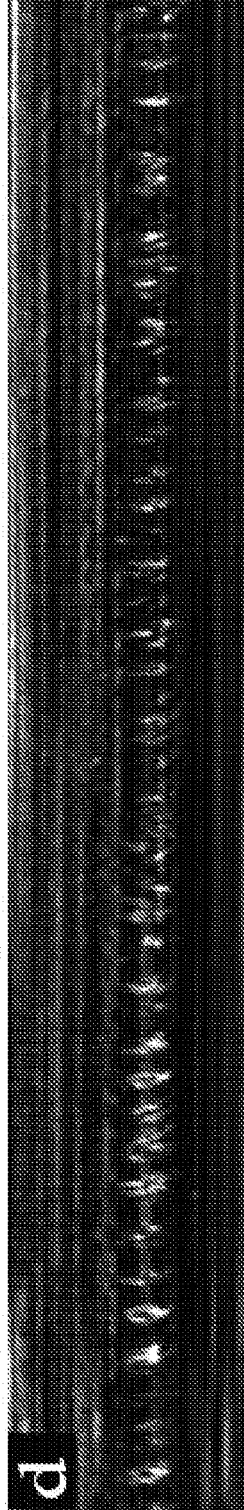

FIG. 19D

FIG.20A

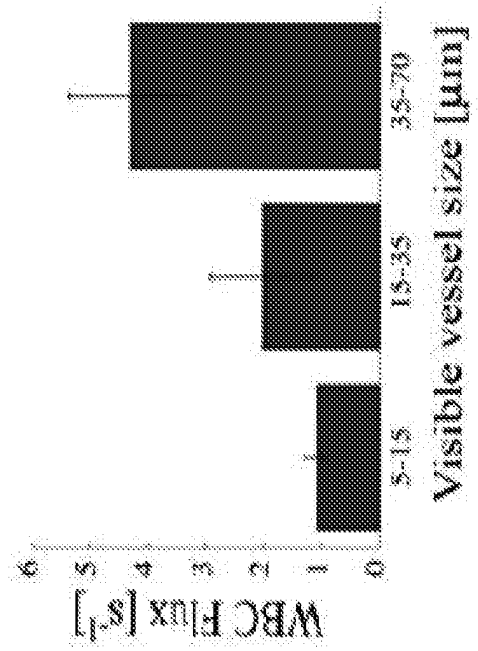
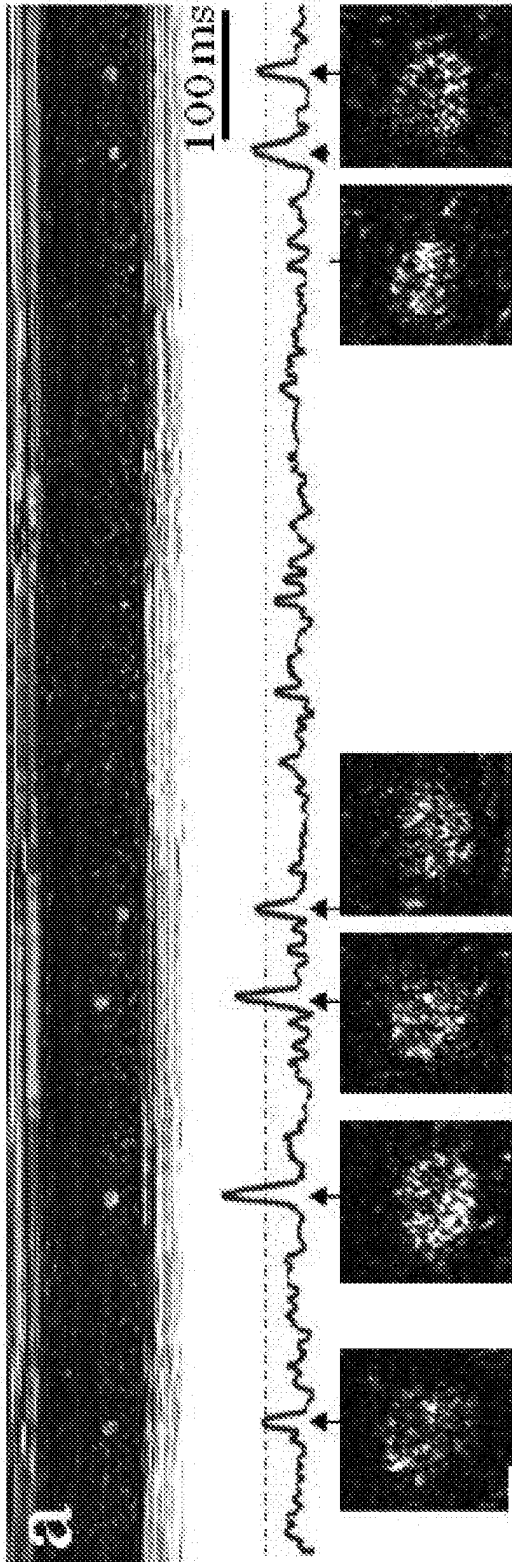

FIG.20B

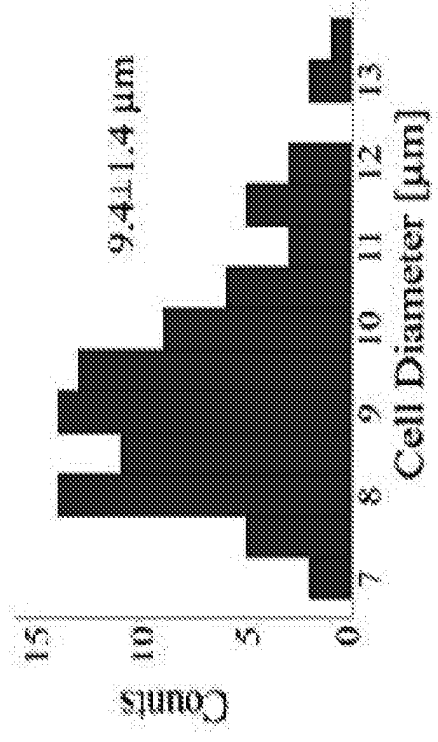

FIG.20C

FIG. 21A



FIG. 21B

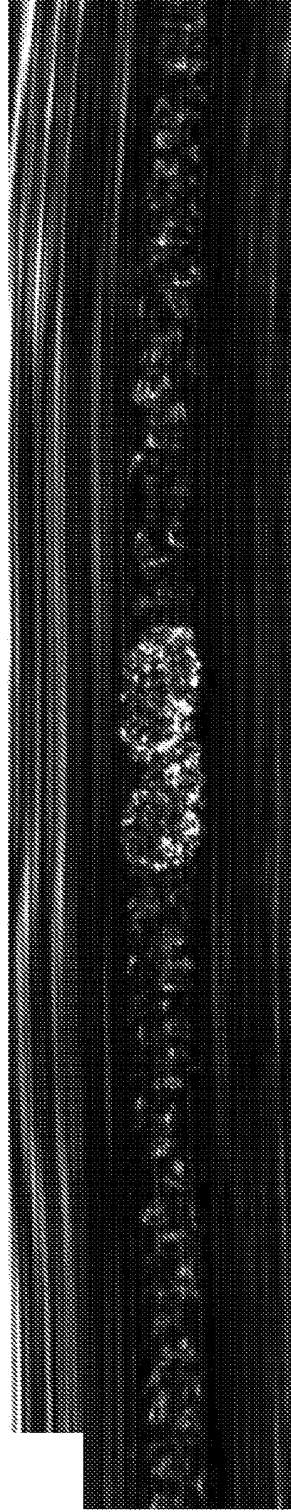
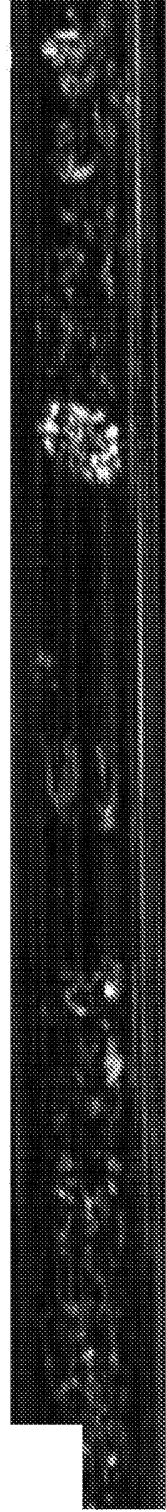

FIG. 21C



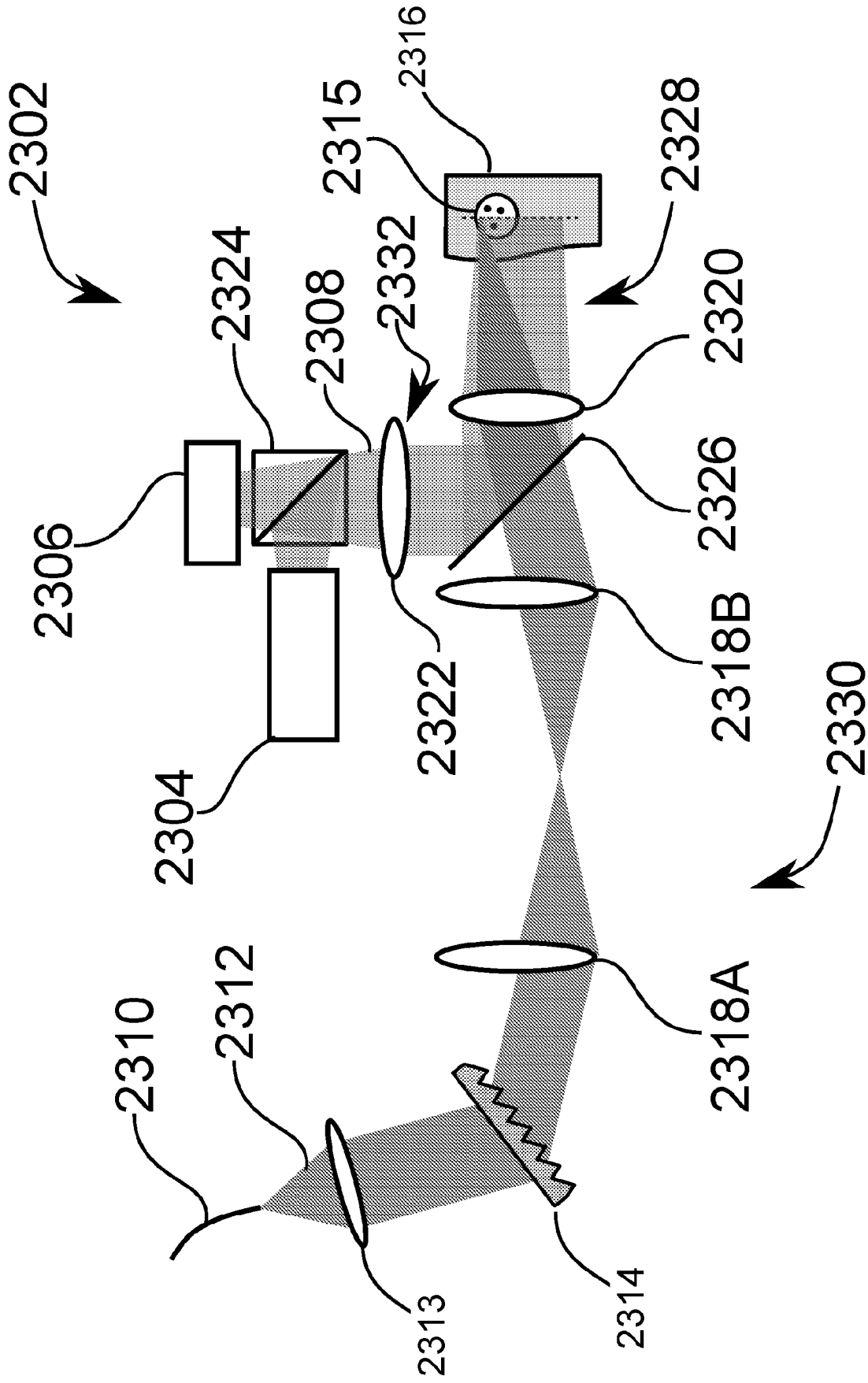

FIG. 22

REFERENCES CITED IN THE DESCRIPTION

This list of references cited by the applicant is for the reader's convenience only. It does not form part of the European patent document. Even though great care has been taken in compiling the references, errors or omissions cannot be excluded and the EPO disclaims all liability in this regard.

Patent documents cited in the description

- US 20080045817 A, Van Beek [0006]
- US 20110044910 A, Lin [0007]
- US 20060134002 A, Lin [0007]
- US 46155809 A [0013]
- US 20100045778 A1 [0013]

Non-patent literature cited in the description

- **D. YELIN et al.** Volumetric sub-surface imaging using spectrally encoded endoscopy. *Optics Express* 1750, February 2008, vol. 16 (3/ 4) [0004]
- **D. YELIN ; L. GOLAN.** Flow cytometry using spectrally encoded confocal microscopy. *Optics*, 2010, vol. 35 (13), 2218-2220 [0005]
- **G. W. SCHMID-SCHONBEIN ; S. USAMI ; R. SKALAK ; S. CHIEN.** The interaction of leukocytes and erythrocytes in capillary and postcapillary vessels. *Microvascular Research*, 1980, vol. 19, 45-70 [0018] [0140] [0141]
- **J. J. BISHOP ; P. R. NANCE ; A. S. POPEL ; M. INTAGLIETTA ; P. C. JOHNSON.** Effect of erythrocyte aggregation on velocity profiles in venules. *Am J Physiol Heart Circ Physiol*, 2001, vol. 280, H222-236 [0018]
- **K. KONSTANTOPOULOS ; S. NEELAMEGHAM ; A. R. BURNS ; E. HENTZEN ; G. S. KANSAS ; K. R. SNAPP ; E. L. BERG ; J. D. HELIUMS ; C. W. SMITH ; L. V. MCINTIRE.** Venous Levels of Shear Support Neutrophil-Platelet Adhesion and Neutrophil Aggregation in Blood via P-Selectin and β 2-Integrin. *Circulation*, 1998, vol. 98, 873-882 [0018]
- **L. GOLAN et al.** High-speed interferometric spectrally encoded flow cytometry. *Optics Letters*, 15 December 2012, vol. 37 (24) [0056]
- **V. HOFFBRAND ; P. MOSS ; J. PETTIT.** Essential Hematology. Blackwell, 2006 [0138] [0141]

专利名称(译)	血管成像系统和方法		
公开(公告)号	EP2804524A1	公开(公告)日	2014-11-26
申请号	EP2013738761	申请日	2013-01-17
[标]申请(专利权)人(译)	技术研究及发展基金有限公司		
申请(专利权)人(译)	TECHNION研究与发展基金有限公司.		
当前申请(专利权)人(译)	TECHNION研究与发展基金有限公司.		
[标]发明人	YELIN DVIR GOLAN LIOR		
发明人	YELIN, DVIR GOLAN, LIOR		
IPC分类号	A61B5/00 A61B5/145		
CPC分类号	A61B5/0066 A61B5/0068 A61B5/0075 A61B5/0084 A61B5/02007 A61B5/14546 A61B5/418 A61B5/489		
代理机构(译)	丹麦美国律师协会		
优先权	61/588631 2012-01-19 US		
其他公开文献	EP2804524B1 EP2804524A4		
外部链接	Espacenet		

摘要(译)

一种用于定位容器的方法，该方法包括用背景光照射容器的至少一部分，所述背景光对容器的所述部分中的颗粒具有基本上高的易吸收性；检测来自容器的所述照射部分的反向散射光；从所述后向散射光再现图像；并识别所述再现图像内的暗区。