

(19)



(11)

EP 2 797 493 B1

(12)

EUROPEAN PATENT SPECIFICATION

(45) Date of publication and mention of the grant of the patent:
30.05.2018 Bulletin 2018/22

(51) Int Cl.:
G01B 9/02 (2006.01) G01B 11/02 (2006.01)
G06K 9/00 (2006.01) A61B 3/10 (2006.01)
A61B 5/00 (2006.01) G06K 9/62 (2006.01)

(21) Application number: **11804967.5**

(86) International application number:
PCT/EP2011/006594

(22) Date of filing: **28.12.2011**

(87) International publication number:
WO 2013/097877 (04.07.2013 Gazette 2013/27)

(54) **PROCESS FOR OPTICAL COHERENCE TOMOGRAPHY AND APPARATUS FOR OPTICAL COHERENCE TOMOGRAPHY**

VERFAHREN FÜR OPTISCHE KOHÄRENZTOMOGRAPHIE UND VORRICHTUNG FÜR OPTISCHE KOHÄRENZTOMOGRAPHIE

PROCESSUS POUR TOMOGRAPHIE À COHÉRENCE OPTIQUE (OCT) ET APPAREIL POUR TOMOGRAPHIE À COHÉRENCE OPTIQUE

(84) Designated Contracting States:
AL AT BE BG CH CY CZ DE DK EE ES FI FR GB GR HR HU IE IS IT LI LT LU LV MC MK MT NL NO PL PT RO RS SE SI SK SM TR

- **WISWEH, Henning**
31234 Edemissen (DE)
- **JEGLORZ, Tobias**
90547 Stein (DE)

(43) Date of publication of application:
05.11.2014 Bulletin 2014/45

(74) Representative: **Katérlé, Axel**
Wuesthoff & Wuesthoff
Patentanwälte PartG mbB
Schweigerstraße 2
81541 München (DE)

(73) Proprietor: **WaveLight GmbH**
91058 Erlangen (DE)

(72) Inventors:
• **MASSOW, Ole**
29303 Bergen (DE)

(56) References cited:
WO-A1-2010/117386 WO-A2-2009/131655
US-A1- 2007 115 481 US-A1- 2008 100 612
US-A1- 2009 028 403 US-A1- 2011 134 394

EP 2 797 493 B1

Note: Within nine months of the publication of the mention of the grant of the European patent in the European Patent Bulletin, any person may give notice to the European Patent Office of opposition to that patent, in accordance with the Implementing Regulations. Notice of opposition shall not be deemed to have been filed until the opposition fee has been paid. (Art. 99(1) European Patent Convention).

Description

[0001] The present invention relates to a process for optical coherence tomography, in particular for generating sets of three-dimensional image data pertaining to an object to be examined. The invention further relates to an apparatus for optical coherence tomography.

[0002] For the purpose of creating a three-dimensional (3D for short) tomogram of an object to be examined with the aid of optical coherence tomography (OCT for short), it is conventional to record a large number of OCT slice images oriented in layers with respect to one another within a volume of the object to be scanned and to orient said slice images subsequently with respect to one another. A 3D registration of such a type can be generated by arranging the individual slice images with respect to one another in each instance in the way in which they were arranged originally at the time of the recording thereof in a coordinate system of the recording apparatus.

[0003] A problem of this approach, however, is that the eye move during the recording of the slice images representing the 3D tomogram. In the course of the subsequent 3D registration of the individual slice images, imaging errors in the 3D tomogram may occur by reason of motion artefacts.

[0004] US 2008/0100612 A1 relates to a system for performing OCT. For image registration, images of the same eye are recorded having the same underlying structure, e.g. a retinal vasculature. The underlying structure in each image is detected and these underlying structures are matched and aligned to each other. Therefore, by registering the underlying structure of one image to the underlying structure of the other image registers the images to one another.

[0005] Both documents US 2011/0134394 A1 and WO 2010/117386 A1 teach to determine the location of a landmark in a first OCT data scan, to repeat this process in a second OCT data scan, and then to compare the newly measured position of the landmark in the second OCT data scan to the previously measured position of the landmark in the first OCT data scan.

[0006] It is an object of embodiments of the invention to specify a process that enables a three-dimensional representation of an object that can be examined by means of optical coherence tomography. Furthermore, an object of embodiments of the invention is to specify an apparatus that operates in accordance with a process of such a type.

[0007] The invention is set out in the independent claims. Preferred embodiments of the invention are outlined in the dependent claims.

[0008] One process provides for recording a plurality of first OCT slice images, each first slice image representing a different slice of an object to be examined. Subsequently a reference figure that is representative of the three-dimensional contour of at least one structural feature of the object is ascertained in a given three-dimensional coordinate system by feature recognition of the at

least one structural feature in the first slice images. Then a plurality of second OCT slice images, each second slice image representing a different slice of the object, are recorded. At least a fraction of the second slice images are displaced in the coordinate system until each second slice image is in feature overlap with the reference figure. Finally, a set of three-dimensional OCT image data is generated at least from the feature-overlapped second slice images.

[0009] In other words: a plurality of first slice images are recorded, the first slice images representing various longitudinal or cross-sectional projections of at least one structural feature of the object. Then the structural feature is recognised, for example by image processing of each one of the first slice images. From this, interpolation coordinates can be ascertained that represent the position of the structural feature in a coordinate system. A reference figure representing the shape of the structural feature can be adapted to the interpolation coordinates. Subsequent thereto, a plurality of second slice images are recorded which also represent various longitudinal or cross-sectional projections of the structural feature. In each of the second slice images the structural feature is recognised, and corresponding positions of the structural feature in the coordinate system are ascertained. In addition, puncture points can be ascertained that represent the position of points of intersection of each one of the second slice images with the reference figure. The positions of the structural feature can be compared with the puncture points. If for a second slice image not all the positions of the structural feature are congruent with the puncture points, the second slice image is displaced, tilted and/or rotated by coordinate transformation in the coordinate system until such time as the second slice image is oriented with respect to the reference figure in exactly fitting manner and the positions of the structural feature are congruent with the puncture points. For the purpose of creating a 3D tomogram of the object, finally the first and/or second slice images can be assembled to form an overall set of image data.

[0010] The present invention consequently makes it possible that during a first (e.g. comparatively short) period of time first slice images are recorded to begin with which may serve to determine the position, orientation and/or size of a reference figure of predetermined shape. The reference figure may subsequently be utilised as a 3D registration support, in order to suitably orient with respect to one another the second slice images recorded during a second period of time (e.g. longer in comparison with the first period of time). Motion artefacts in the 3D tomogram of the object, caused by movement of the object, are thereby avoided. The 3D registration consequently contributes to the creation of a 3D projection of the object with reduced errors.

[0011] The first and/or second slice images constitute, for example, so-called B-scans. These represent flat, two-dimensional (2D for short) OCT projections of the

object. A B-scan can be obtained on the basis of a plurality of line scans, so-called A-scans. An A-scan constitutes a measured OCT interferogram and represents a rectilinear, one-dimensional (1D for short) OCT projection over an axial distance of the object. A B-scan may be formed from several A-scans of equal length situated in one plane and running parallel to one another. All the slice images and the set of image data may also be stored in a suitable storage medium.

[0012] The object to be examined may be, for example, an eye. The object may be any other suitable physical entity that can be imaged, such as a workpiece with internal structural features.

[0013] The position and the orientation of the structural feature may reproduce, in substitutional manner, the position and the orientation of the object in a coordinate system. For this purpose the structural feature extends, for example, over an extensive region on or in the object. If the object is an eye, the structural feature may be, for example, the outer and/or inner margin of the iris and/or the limbus of the eye. Alternatively the structural feature may be a surface or internal structural face of the human lens and/or the cornea.

[0014] The reference figure may simulate the geometry of the structural feature schematically. For this purpose the reference figure may represent a simplified model of the structural feature that substantially reproduces the position and the orientation of the structural feature in a coordinate system. Accordingly it is conceivable that the reference figure represents a geometrical shape such as an ellipse, a circular disc, a circular disc with concentrically inscribed circular hole, a sphere, a spherical shell, a cylinder, a hollow cylinder with finite thickness of the circumferential surface, or the like. If the structural feature is, for example, the margin of the iris, the reference figure may exhibit a circular shape and/or elliptical shape. If the structural feature is, for example, both the inner and outer margins of the iris, the reference figure may represent a geometrical shape that comprises two circular shapes and/or elliptical shapes that have a certain spatial positioning and orientation with respect to one another.

[0015] The term "displacing" refers to changing the position and/or the orientation of an entity in any suitable manner. For example, a coordinate transformation may be applied to the position and/or the orientation to change the position and the orientation, respectively. A coordinate transformation may include at least one spatial translation parallel or antiparallel to the x-, y- and/or z-axes of a coordinate system and/or at least one spatial rotation about an axis of rotation along the x-, y- and/or z-axes and/or a spatial rotation about an axis of rotation between the x-, y- and/or z-axes by a positive or negative angle in the coordinate system. Accordingly, the term "displacing" may include an arbitrary tilting in space. A coordinate transformation preserves some or all the relative spacings between individual constituents of the projection within the second slice image. Merely the position

and the orientation of the slice image as such are changed. The space coordinates of each image pixel of the second slice image are affected, but not the colour value or tonal value of the image pixel.

[0016] In certain embodiments, a first period of time expended overall for the recording of the plurality of first slice images may be shorter than a second period of time expended overall for the recording of the plurality of second slice images. The first period of time is determined, inter alia, from the number of first slice images, from the number of interferograms recorded per slice image, and from the recording-time of an individual one of these interferograms. The recording-time of an individual interferogram is determined, inter alia, from the exposure-time, from a following period of reworking (for instance, for the sampling of the interferogram, for possible image-processing steps such as Fourier transformations, image-recognition processes and such like) and from the time needed for storage. Analogous remarks apply to the second period of time.

[0017] In certain embodiments, the number of first slice images may be smaller than the number of second slice images. For example, the ratio of the number of first slice images to the number of second slice images amounts to 1:2, 1:5, 1:10 or 1:100.

[0018] Furthermore, the recording time for a first slice image may be shorter than the recording time for a second slice image. For example, the exposure time, the period of reworking and/or the storage time of the first slice images is/are shorter than corresponding time intervals for the second slice images. In particular, for each slice image a plurality of A-scans of the object are recorded that is smaller than the number of A-scans for the second slice images. Accordingly, a first slice image may consist of 200 A-scans, and the frequency of recording A-scans may amount to 70 kHz. A second slice image consists, for example, of 500 to 2000 A-scans, which are recorded at a recording-rate from 20 kHz to 70 kHz.

[0019] In certain embodiments, the recording-time for a first slice image may be sufficiently short that motion artefacts during the recording of the first slice image, caused by typical movements of the object, are substantially avoided.

[0020] The first slice images may be recorded by means of B-scans that are distributed over the object in a regular pattern. For example, the first slice images can be recorded by means of B-scans that are distributed in a cross-grid pattern. For example, first slice images oriented orthogonally with respect to one another are acquired, whereby in each instance two adjacent first slice images exhibit a constant spacing from one another.

[0021] As an alternative, the first slice images may be oriented with respect to one another in the shape of a star in such a manner that the first slice images intersect one another in a straight line. The straight line may coincide with an axis of symmetry of the object and/or may run through points of the object that have been marked out. For example, the straight line is centred with the pu-

pillary centre of an eye and runs along the optical axis thereof or through the apex of the cornea.

[0022] The first slice images may be recorded in such a distribution pattern that points of intersection of the first slice images with the reference figure are situated, distributed substantially at equal spacings, along the reference figure after the reference figure has been adapted to the first slice images.

[0023] Additionally or alternatively, the first slice images may be recorded in such a distribution pattern that the number n of points of intersection at which the reference figure intersects the surface normals of the first slice images at an angle within the range of more than 30° and less than 60° , after the reference figure has been adapted to the first slice images, amounts to at least $2(N-2)$, where N is the number of first slice images. In other words: of the N first slice images of, for example, an orthogonal cross pattern, after the reference figure has been adapted at least $N-2$ first slice images are intersected by the reference figure in such a manner that the reference figure includes with the respective surface normals of the first slice images at the respective point of intersection an angle of more than 30° and less than 60° . In this case there are a total of at least $n=2(N-2)$ such points of intersection, whereby the n points of intersection differ from one another, i.e. amongst themselves are not situated on top of one another.

[0024] Additionally or alternatively, the first slice images may be recorded in such a distribution pattern that the number n of points of intersection at which the reference figure intersects the first slice images, after the reference figure has been adapted to the first slice images, suffices for describing the geometry of the reference figure.

[0025] The second slice images may also be recorded by means of B-scans that are distributed over the object in a certain pattern. The pattern may include, for example, a cross-grid pattern. In this case the second slice images may have been oriented orthogonally and/or parallel to one another. Additionally or alternatively, the pattern may include two cross-grid patterns placed over one another in angle-offset manner. For example, the angle amounts to about 45° . Additionally or alternatively, the pattern may include three cross-grid patterns placed over one another in angle-offset manner. For example, the angle amounts to about 60° .

[0026] The pattern of the second slice images may be irregular. For instance, the grid-line density of a cross pattern in a central region of the reference figure is lower than in a region of the reference figure remote from the centre. For this purpose a spacing of two adjacent second slice images oriented parallel to one another that intersect the region of the reference figure remote from the centre may be smaller than a spacing of two adjacent second slice images oriented parallel to one another that intersect the central region of the reference figure. If the second slice images also contain cross-sectional projections of the cornea of a human eye, on the basis of the irregular pattern the aspherical regions of the cornea can

be represented with higher resolution than can regions of the cornea in the vicinity of the apex of the cornea. The density of cross-sectional projections of the cornea is accordingly higher in a region representing the aspherical region of the cornea. Positions of these cross-sectional projections may serve as interpolation nodes for the segmentation of structural layers in the object being examined, or for an adaptation of a predetermined surface shape to the cornea by means of Zernike polynomials.

[0027] The process may additionally include the following step: by image processing in a first and/or second slice image an indication of motion artefacts that have occurred during the recording of the respective slice image is recognised. An indication of motion artefacts includes, for example, a discontinuity, a waviness, a contraction and/or an elongation within a profile in the slice image representing the structural feature and/or a low signal-to-noise ratio (SNR for short) of adjacent A-scans of a slice image. This step may take place 'online' before the next slice image is acquired in accordance with the distribution pattern. If motion artefacts are discernible within a first and/or second slice image, the acquisition of the defective slice image may be repeated until the slice image is present in flawless manner. But the acquisition of an individual first and/or second slice image may take place so quickly that the recording time required for the acquisition is short in comparison with a timescale that is typical of eye movements.

[0028] An apparatus for optical coherence tomography comprises an OCT image-acquisition unit and a computer arrangement that has been set up to control the OCT image-acquisition unit in such a manner that the latter records a plurality of first OCT slice images, each first slice image representing a different slice of an object, to ascertain a reference figure that is representative of the three-dimensional contour of at least one structural feature of the object in a given three-dimensional coordinate system by feature recognition of the at least one structural feature in the first slice images, to control the OCT image-acquisition unit in such a manner that the OCT image-acquisition unit records a plurality of second OCT slice images, each second slice image representing a different slice of the object, to displace at least a fraction of the second slice images in the coordinate system until each second slice image is in feature overlap with the reference figure, and to generate a set of three-dimensional OCT image data at least from the feature-overlapped second slice images.

[0029] The apparatus may have been set up to bring about a process, described above, for optical coherence tomography.

[0030] To the extent that a process or individual steps of a process for optical coherence tomography is/are described in this description, the process or individual steps of the process can be executed by an appropriately configured apparatus. Analogous remarks apply to the elucidation of the mode of operation of an apparatus that

executes process steps. To this extent, apparatus features and process features of this description are equivalent.

[0031] The invention will be elucidated further in the following on the basis of the appended drawings, of which:

- Fig. 1 shows, in schematic block representation, elements of an apparatus for optical coherence tomography according to one embodiment,
- Fig. 2 shows, in top view schematically, an example of a distribution pattern in which the first slice images are recorded, with a reference figure drawn in,
- Fig. 3 shows, in a three-dimensional view schematically, the distribution pattern from Fig. 2,
- Figs. 4a and 4b show schematically examples of a first slice image,
- Fig. 5 shows, in top view schematically, a further example of a distribution pattern in which the first slice images are recorded,
- Figs. 6a and 6b show, in top view schematically, examples of distribution patterns in which the second slice images are recorded,
- Figs. 7a to 7c show schematically an example relating to the displacing of a second slice image parallel to an x-axis until the second slice image is in feature overlap with a reference figure,
- Figs. 8a to 8c show schematically an example relating to the displacing of a second slice image antiparallel to a y-axis until the second slice image is in feature overlap with a reference figure,
- Figs. 9a to 9c show schematically an example relating to the displacing of a second slice image parallel to a z-axis until the second slice image is in feature overlap with a reference figure,
- Figs. 10a to 10c show schematically an example relating to the rotation of a second slice image about an axis of rotation running parallel to an x-axis until the second slice image is in feature over-

lap with a reference figure, and

Figs. 11a to 11e show schematically an example relating to the displacing of a second slice image until the second slice image is in feature overlap with a reference figure.

[0032] The apparatus for optical coherence tomography in Fig. 1 - denoted generally therein by 10 - serves for creating 3D tomograms of an object shown in the exemplary case as a human eye 12. The optical coherence tomography is based, for example, on so-called time-domain (TD for short) OCT or on so-called frequency-domain (FD for short) OCT.

[0033] The apparatus 10 includes a light-source 14 for emitting coherent light. The light-source 14 is designed, for example, for the purpose of FD OCT as a tuneable light-source or emits a spectrum of coherent light that is broadband within the frequency space. The light emitted from the light-source 14 is directed onto a beam-splitter 16. The beam-splitter 16 is a constituent part of a Michelson interferometer 18 and splits up the incident optical output in accordance with a predetermined splitting ratio, for example 50:50. One ray 20 runs within a reference arm; the other ray 22 runs within a specimen arm. Instead of the free-space setup represented in Fig. 1 the Michelson interferometer 18 may also have been realised partly or entirely with the aid of fibre-optic components.

[0034] The light that has been branched off in the reference arm impinges onto a mirror 24 which reflects the light back onto the beam-splitter 16 collinearly. For the purpose of TD OCT the mirror 24 may be displaceable along the direction of propagation of the ray 20. The light that has been branched off in the specimen arm impinges onto the object 12 to be examined, which back-scatters or reflects back the light in the direction of the beam-splitter 16.

[0035] In Fig. 1 a three-dimensional Cartesian coordinate system of the apparatus 10 has been drawn in schematically which serves as coordinate system in the following. In this connection the z-axis represents the direction of propagation of the light ray 22 in the region immediately upstream of the object 12.

[0036] Within the specimen arm further optical elements 26 and adjusting components 28 are provided, which have been set up to focus the light ray 22 coming in from the beam-splitter 16 onto the object 12 and to adjust the focus position (for example in the lateral directions x, y or in all three directions in space x, y, z). A computer arrangement 30 controls the adjusting components 28 for the purpose of obtaining 1D, 2D and/or 3D tomograms.

[0037] The light back-scattered from the object 12 in the specimen arm is collinearly superimposed at the beam-splitter 16 with the light reflected back from the mirror 24 in the reference arm so as to form an interference beam 32. The optical path lengths in the reference

arm and specimen arm are substantially equally long, so that the interference beam 32 displays an interference between the constituent rays 20, 22 from reference arm and specimen arm. A detector 34' registers the intensity of the interference beam 32 as a function of the time, the wavelength and/or the wave number. For this purpose the detector 34' may take the form of a photodiode or spectrometer.

[0038] The signal registered by the detector 34' is transferred to the control arrangement 30 which ascertains 2D OCT slice images therefrom. In this sense the computer arrangement 30, the light-source 14, the detector 34' and the Michelson interferometer 18, inclusive of the optical elements 26 and the adjusting components 28, may be understood as an OCT image-acquisition unit 33 which is controlled by the computer arrangement 30.

[0039] For the purpose of creating a 3D tomogram of the object 12 the computer arrangement 30 controls the adjusting components 28 in accordance with such a scan pattern that a 3D registration of the acquired slice images within a scanned volume of the object 12 with respect to one another can be undertaken. This process will be described in detailed manner in the following with reference to Figs. 2 to 11.

[0040] First of all, a plurality of first slice images 34, each first slice image representing a different slice of the object 12, are recorded and are stored in a memory of the computer arrangement 30. The first slice images 34 represent OCT B-scans which are obtained from a large number of OCT A-scans. A first slice image 34 consists of, for example, 200 A-scans. Furthermore, a short exposure-time is chosen in which the individual A-scans are recorded. The rate of recording of A-scans amounts to, for example, 70 kHz.

[0041] As shown in Fig. 2, in the present exemplary case three horizontal and three vertical first slice images 34 are acquired in an orthogonal cross pattern 35 similar to a chessboard. In this example the horizontal and vertical first slice images 34 are arranged parallel to one another, the spacing d of adjacent first slice images 34 being constant for all adjacent slice images 34. In Fig. 3 the distribution pattern, shown in Fig. 2, of the first slice images 34 and a part of the eye 12 are illustrated again three-dimensionally.

[0042] As an alternative to the distribution pattern shown in Figs. 2 and 3, the distribution pattern, shown in Fig. 5, of first slice images 34 is also possible. In this case the first slice images 34 have been oriented with respect to one another in the shape of a star in such a manner that the first slice images 34 intersect one another in a straight line G . In the example shown in Fig. 5 the straight line G is centred with the pupillary centre of the eye 12 and runs along the optical axis of the eye 12, that is to say, substantially parallel to the z -axis.

[0043] A first slice image 34 is shown in Figs. 4a and 4b. The first slice images 34 represent cross-sectional projections of at least one structural feature 36 of the object 12. In Fig. 4a the structural feature 36 is, for ex-

ample, the outer margin of the iris 38 in the eye 12. In Fig. 4b the structural feature 36 is, for example, the outer and inner margins of the iris 38. Besides the iris 38, in the first slice image 34 the cornea 40, for example, is also imaged.

[0044] In the first slice images 34 which have been prepared the computer arrangement 30 now recognises the structural feature 36 on the basis of an image-recognition algorithm and determines the position(s) 42 thereof in the coordinate system of the apparatus 10. In Figs. 2, 4a and 4b these positions 42 are labelled by means of small circles filled in with black.

[0045] As shown in Fig. 2, the computer arrangement 30 subsequently adapts a reference figure 44 that is representative of the three-dimensional contour of the structural feature 36 to the positions 42 ascertained beforehand serving as interpolation nodes. In Fig. 2 the reference figure 44 represents a circular shape in imitation of the margin of the iris 38, which is predetermined by a midpoint M (i.e. a 3D space coordinate) and a further parameter R defining the radius. The adapting or fitting of the reference figure 44 to the interpolation nodes 42 is based on a mathematical optimisation method in order to determine (to estimate) the unknown parameters M and R of the reference figure 44 for a series of interpolation nodes 42.

[0046] The spacing d of the slice images 34 is chosen in such a way that the interpolation nodes 42 have an almost equidistant spacing on the periphery of the reference figure 44 after the reference figure 44 has been adapted to the first slice images 34.

[0047] Additionally or alternatively, the first slice images 34 can be recorded in such a distribution pattern 35 that the number n of points of intersection at which the reference figure 44 intersects the first slice images 34, in each instance at an angle within the range of more than 30° and less than 60° in relation to the surface normal of the respective slice image 34, amounts to at least $2(N-2)$, where N is the number of first slice images 34, after the reference figure 44 has been adapted to the first slice images 34. This is represented in exemplary manner in Fig. 2: of the six first images 34 (i.e. $N = 6$) of the orthogonal cross pattern 35, after the reference figure 44 has been adapted four first slice images 34 are intersected by the reference figure 44 in such a manner that the reference figure 44 includes with the respective surface normals of the first slice images 34 at the respective point of intersection an angle of more than 30° and less than 60° (i.e. $n=2(N-2)=2(6-2)=8$).

[0048] Additionally or alternatively, the first slice images 34 can be recorded in such a distribution pattern 35 that the number n of points of intersection at which the reference figure 44 intersects the first slice images 34 suffices for describing the geometry of the reference figure 44 after the reference figure 44 has been adapted to the first slice images 34. This is again represented in Fig. 2: the six first slice images 34 of the orthogonal cross pattern 35 are intersected by the reference figure 44 at

twelve points of intersection after the reference figure 44 has been adapted. Each of these twelve points of intersection is described in three-dimensional space by three parameters (space coordinates x , y , z), so that a total of 36 parameters are available for fitting the reference figure 44. For example, the circle shown in Fig. 2 is described by a midpoint in three-dimensional space (consisting of three parameters) and a radius (vector) in three-dimensional space (likewise consisting of three parameters). For the purpose of fitting the reference figure 44, at least six parameters are accordingly required, so that the 36 parameters of the twelve points of intersection between the reference figure 44 and the first slice images 34 are sufficient.

[0049] Subsequently a plurality of second slice images 46, each second slice image representing a different slice of the object 12, are recorded and stored. The second slice images 46 also represent OCT B-scans which are obtained from a large number of OCT A-scans. The second slice images 46 consist, for example, of 2000 A-scans per B-scan, the A-scans being recorded at a recording-rate from, for example, 20 kHz to 70 kHz. In comparison with the first slice images 34, the second slice images 46 therefore offer higher statistics and image quality. This permits higher-quality, in the sense of a signal-to-noise ratio, second slice images 46 to be created.

[0050] As shown in Figs. 6a and 6b, the second slice images 46, in the course of the acquisition thereof, are distributed over the object 12 in accordance with an irregular pattern 45. In Figs. 6a and 6b, in addition the reference figure 44 ascertained beforehand has been drawn in. The irregular distribution pattern includes a cross-grid pattern, the grid-line density of which in a central region 47a of the reference figure 44 is lower than in a region 47b of the reference figure 44 remote from the centre. In Figs. 6a and 6b the central region 47a and the region 47b remote from the centre are separated from one another in exemplary manner by a dashed line. Consequently a spacing of two adjacent second slice images 46a oriented parallel to one another in the central region 47a of the reference figure 44 is larger than a spacing of two adjacent second slice images 46b oriented parallel to one another in the region 47b of the reference figure 44 remote from the centre.

[0051] In Fig. 6a the second slice images 46 are arranged in such a manner that they are oriented orthogonally and/or parallel to one another. But alternatively the distribution pattern shown in Fig. 6b is also possible, in which the second slice images are arranged in such a manner that they are oriented orthogonally and/or parallel to one another and/or intersect one another at an angle of 45 degrees. Accordingly, the irregular pattern includes two cross-grid patterns placed on top of one another in angle-offset manner.

[0052] In Figs. 7a to 11e schematic representations of second slice images 46 are shown. The second slice images 46 likewise represent cross-sectional projections of the structural feature 36. In the second slice images

46 the cornea 40, for example, is also imaged. As in the case of the first slice images 34, on the basis of image processing the computer arrangement 30 ascertains in the second slice images 46 the structural feature 36 and determines the position(s) 48 thereof in the coordinate system of the apparatus 10. In Figs. 7a to 11e these positions 48 are labelled by means of small black circles with inscribed black cross.

[0053] The reference figure 44 can also be seen in Figs. 7a to 11e, wherein the margin thereof is represented by a continuous line if the reference figure 44, viewed from the observer, runs spatially in front of the second slice image 46, and the margin thereof is represented by a dashed line if the reference figure 44, viewed from the observer, runs spatially behind the second slice image 46.

[0054] For each second slice image 46 the computer arrangement 30 ascertains by calculation the positions of puncture points 50 at which the reference figure 44 intersects the second slice image 46. The (original) position and orientation of a second slice image 46 which are required for this purpose are predetermined by the distribution pattern 45. The puncture points 50 are labelled in Figs. 7a to 11e, like the positions 48, by means of small black circles with inscribed black cross. The puncture points 50 are situated at the transition from the continuous margin to the dashed margin of the reference figure 44.

[0055] If not all the positions 48 are in congruence with the puncture points 50, the computer arrangement 30 displaces a second slice image 46 in the coordinate system of the apparatus 10 until all the positions 48 in the second slice image 46 are congruent with the puncture points 50. For this purpose the computer arrangement 30 ascertains a suitable coordinate transformation for the second slice image 46. In the course of the transformation all the relative spacings between individual projection constituents 40, 48 within the second slice image 46 are preserved. Merely the position and the orientation of the slice image 46 as such are changed.

[0056] In Figs. 7a to lie exemplary displacements, rotations or coordinate transformations are shown, on the basis of which second slice images 46 are oriented with respect to a reference figure 44. Small arrows shown therein illustrate the respective displacement or rotation.

[0057] Accordingly, Figs. 7a to 7c show a translation of a second slice image 46 parallel to the x-axis. In Fig. 7a the computer arrangement 30 recognises that the positions 48 are not congruent with the puncture points 50, since the spacing between the two positions 48 is shorter than between the puncture points 50. The reason for this is that the eye 12 has been displaced effectively antiparallel to the x-axis during the period of time between creation of the reference figure 44 and the recording of the second slice image 46. With a view to compensating the eye movement, the computer arrangement 30 carries out a coordinate transformation for the second slice image 46, whereby the space coordinates of each image pixel

in the second slice image 46 are corrected in such a manner that after the coordinate transformation the positions 48 are congruent with the puncture points 50.

[0058] In this way the second slice images 46 are oriented, image by image, with respect to the reference figure 44 and are stored. This type of 3D registration enables the creation of 3D tomograms of the object 12 that are free from motion artefacts. In this manner, motion artefacts such as, for example, level errors, rotation errors orthogonal to the optical axis and/or lateral movements can be compensated. Accordingly, the computer arrangement 30 generates from the feature-overlapping second slice images 46 a set of three-dimensional OCT image data which is then displayed on a display unit 52 of the apparatus 10 as a 3D tomogram of the object 12 to be examined.

[0059] In Figs. 8a to 8c a further coordinate transformation of a second slice image 46 is shown, in the course of which the second slice image 46 is displaced antiparallel to the y-axis. In Figs. 9a to 9c a coordinate transformation for a second slice image 46 is again shown. In this case the displacement is effected parallel to the z-axis of the coordinate system of the apparatus 10.

[0060] In Figs. 10a to 10c a spatial rotation of a second slice image 46 is shown. Although in Fig. 10a one position 48 is initially congruent with one puncture point 50, the second position 48 does not tally with the second puncture point 50. The second slice image 46 is therefore rotated about an axis of rotation running parallel to the x-axis, see Fig. 10b.

[0061] In Figs. 11a to 11e a somewhat more complex transformation of a second slice image 46 is shown. In this example the reference figure 44 represents both the inner and outer margins of the iris 38 of the eye 12. The reference figure consists of two circular shapes arranged parallel to one another, the midpoints of which lie on a straight line perpendicular to the surfaces of the circular shapes.

[0062] In Fig. 11a it can be discerned that in the second slice image 46 four positions 48 corresponding to a cross-section through the inner and outer margins of the iris were recognised by the computer arrangement 30 but the reference figure 44 intersects the second slice image 46 merely at two puncture points 50. In Fig. 11b it can be seen how the second slice image 46 is therefore displaced firstly antiparallel to the x-axis until four puncture points 50 with relative spacings corresponding to the relative spacings of the positions 48 are present, see Fig. 11c. In Fig. 11d a spatial translation of the second slice image 46 parallel to the z-axis is subsequently effected until, as shown in Fig. 11e, a total overlap of features occurs.

[0063] The computer arrangement 30 has furthermore been set up to recognise, by image processing in a first and/or second slice image 34, 46, an indication of motion artefacts that have arisen during the recording of the respective slice image 34, 46. If motion artefacts are recognisable within a slice image 34, 46, the computer ar-

angement 30 controls the OCT image-acquisition unit 33 in such a manner that the acquisition of the defective slice image 34, 46 is repeated. But the acquisition of a slice image 34, 46 is effected so quickly that the individual B-scan is free from motion artefacts.

[0064] Unless expressly stated otherwise, identical reference symbols in the Figures stand for identical or identically-acting elements. In other respects, an arbitrary combination of the features elucidated in the Figures in connection with individual embodiments is conceivable.

Claims

1. Process for optical coherence tomography, comprising:

- recording a plurality of first OCT slice images (34), each first slice image (34) representing a different slice of an object (12),
- ascertaining a reference figure (44) that is representative of the three-dimensional contour of at least one structural feature (36) of the object (12) in a given three-dimensional coordinate system (x, y, z) by feature recognition of the at least one structural feature (36) in each of the first slice images (34),
- recording a plurality of second OCT slice images (46), each second slice image (46) representing a different slice of the object (12), wherein a time-period needed for the recording of a first slice image (34) is shorter than a time-period needed for the recording of a second slice image (46),
- displacing at least a fraction of the second slice images (46) in the coordinate system (x, y, z) until each second slice image (46) is in feature overlap with the reference figure (44), and
- generating a set of three-dimensional OCT image data at least from the feature-overlapped second slice images (46).

2. Process according to Claim 1, wherein the number of first slice images (34) is smaller than the number of second slice images (46).

3. Process according to one of the preceding claims, wherein for each slice image (34, 46) a plurality of A-scans of the object are recorded, the number of A-scans for the first slice images (34) being in each instance smaller than for the second slice images (46), and/or wherein the first slice images (34) are recorded by means of B-scans that are distributed over the object (12) in a regular pattern (35), and/or wherein the first slice images (34) are recorded by means of B-scans that are distributed in a cross-grid pattern (35).

4. Process according to one of the preceding claims, wherein the first slice images (34) are recorded in such a distribution pattern (35) that points of intersection of the first slice images (34) with the reference figure (44) are situated, distributed substantially at equal spacings, along the reference figure (44) and/or that the number n of points of intersection at which the reference figure (44) intersects the first slice images (34) in each instance at an angle within the range of more than 30° and less than 60° in relation to the surface normal of the respective slice image amounts to at least $2(N-2)$, where N is the number of first slice images (34), and/or that the number n of points of intersection at which the reference figure (44) intersects the first slice images (36) suffices for describing the geometry of the reference figure (44) after the reference figure (44) has been adapted to the first slice images (34).
5. Process according to one of the preceding claims, wherein the second slice images (46) are recorded by means of B-scans that are distributed over the object (12) in an irregular pattern (45).
6. Process according to Claim 5, wherein the irregular pattern (45) includes a cross-grid pattern, the grid-line density of which in a central region (47a) of the reference figure (44) is lower than in a region (47b) of the reference figure (44) remote from the centre, and/or wherein the irregular pattern (45) includes at least two cross-grid patterns placed over one another in angle-offset manner, whereby in particular the pattern includes two cross-grid patterns placed over one another in angle-offset manner with an angle of about 45° or includes three cross-grid patterns placed over one another in angle-offset manner with an angle of about 60° .
7. Process according to one of the preceding claims, wherein the ascertaining of the reference figure (44) includes an adapting of at least one circular figure to feature positions (42) of the at least one structural feature (36) in the first slice images (34), and/or wherein the object (12) is a human eye and the at least one structural feature (36) includes an inner iris margin and/or an outer iris margin of the eye and/or a limbus of the eye.
8. Apparatus (10) for optical coherence tomography, comprising an OCT image-acquisition unit (33) and a computer arrangement (30) that has been set up
- to control the OCT image-acquisition unit (33) in such a manner that the OCT image-acquisition unit (33) records a plurality of first OCT slice images (34), each first slice image (34) representing a different slice of an object (12),
 - to ascertain a reference figure (44) that is representative of the three-dimensional contour of at least one structural feature (36) of the object (12) in a given three-dimensional coordinate system (x, y, z) by feature recognition of the at least one structural feature (36) in each of the first slice images (34),
 - to control the OCT image-acquisition unit (33) in such a manner that the OCT image-acquisition unit (33) records a plurality of second OCT slice images (46), each second slice image (46) representing a different slice of the object (12), wherein the OCT image-acquisition unit (33) has been set up to record a first slice image (34) during a first time-period and a second slice image (46) during a second time-period, the first time-period being shorter than the second time-period,
 - to displace at least a fraction of the second slice images (46) in the coordinate system (x, y, z) until each second slice image (46) is in feature overlap with the reference figure (44), and
 - to generate a set of three-dimensional OCT image data at least from the feature-overlapped second slice images (46).
9. Apparatus (10) according to Claim 8, wherein the OCT image-acquisition unit (33) has been set up to record a number of first slice images (34) and a number of second slice images (46), the number of first slice images (34) being smaller than the number of second slice images (46).
10. Apparatus (10) according to one of Claims 8 or 9, wherein the OCT image-acquisition unit (33) has been set up to record for each slice image (34, 46) a plurality of A-scans of the object, the number of A-scans for the first slice images (34) being in each instance smaller than for the second slice images (46), and/or wherein the OCT image-acquisition unit (33) has been set up to record the first slice images (34) by means of B-scans that are distributed over the object (12) in a regular pattern (35), and/or wherein the OCT image-acquisition unit (33) has been set up to record the first slice images (34) by means of B-scans that are distributed in a cross-grid pattern (35).
11. Apparatus (10) according to one of Claims 8 to 10, wherein the OCT image-acquisition unit (33) has been set up to record the first slice images (34) in such a distribution pattern (35) that points of intersection of the first slice images (34) with the reference figure (44) are situated, distributed substantially at equal spacings, along the reference figure (44) and/or that the number n of points of intersection at which the reference figure (44) intersects the first slice images (34) in each instance at an angle within the range of more than 30° and less than 60° in re-

lation to the surface normal of the respective slice image amounts to at least $2(N-2)$, where N is the number of first slice images (34), and/or that the number n of points of intersection at which the reference figure (44) intersects the first slice images (34) suffices for describing the geometry of the reference figure (44) after the reference figure (44) has been adapted to the first slice images (34).

12. Apparatus (10) according to one of Claims 8 to 11, wherein the OCT image-acquisition unit (33) has been set up to record the second slice images (46) by means of B-scans that are distributed over the object (12) in an irregular pattern (45).

13. Apparatus (10) according to Claim 12, wherein the OCT image-acquisition unit (33) has been set up to record the second slice images (46) in accordance with the irregular pattern (45), the irregular pattern (45) including a cross-grid pattern, the grid-line density of which in a central region (47a) of the reference figure (44) is lower than in a region (47b) of the reference figure (44) remote from the centre, and/or wherein the OCT image-acquisition unit (33) has been set up to record the second slice images (46) in accordance with the irregular pattern (45), the irregular pattern (45) including at least two cross-grid patterns placed over one another in angle-offset manner, whereby in particular the pattern includes two cross-grid patterns placed over one another in angle-offset manner with an angle of about 45° or includes three cross-grid patterns placed over one another in angle-offset manner with an angle of about 60° .

14. Apparatus (10) according to one of Claims 8 to 13, wherein the computer arrangement has been set up to ascertain the reference figure (44) by an adapting of at least one circular figure to feature positions (42) of the at least one structural feature (36) in the first slice images (34), and/or wherein the object (12) is a human eye and the at least one structural feature (36) includes an inner iris margin and/or an outer iris margin of the eye and/or a limbus of the eye.

Patentansprüche

1. Verfahren für optische Kohärenztomographie, umfassend:

- Aufzeichnen einer Vielzahl erster OCT-Schichtbilder (34), wobei jedes erste Schichtbild (34) eine andere Schicht eines Objekts (12) repräsentiert,
- Ermitteln einer Referenzfigur (44), die repräsentativ für die dreidimensionale Kontur des mindestens einen Strukturmerkmals (36) des

Objekts (12) in einem gegebenen dreidimensionalen Koordinatensystem (x, y, z) ist, durch Merkmalerkennung des mindestens einen Strukturmerkmals (36) in jedem der ersten Schichtbilder (34),

- Aufzeichnen einer Vielzahl zweiter OCT-Schichtbilder (46), wobei jedes Schichtbild (46) eine andere Schicht des Objekts (12) repräsentiert, wobei ein Zeitraum, der für das Aufzeichnen eines ersten Schichtbildes (34) benötigt wird, kürzer als ein Zeitraum ist, der für das Aufzeichnen eines zweiten Schichtbildes (46) benötigt wird,

- Verschieben mindestens einer Fraktion der zweiten Schichtbilder (46) in dem Koordinatensystem (x, y, z), bis jedes zweite Schichtbild (46) in Merkmalsüberlappung mit der Referenzfigur (44) ist, und

- Generieren eines Satzes von dreidimensionalen OCT-Bilddaten mindestens aus den merkmalsüberlappenden zweiten Schichtbildern (46).

2. Verfahren nach Anspruch 1, wobei die Anzahl der ersten Schichtbilder (34) kleiner als die Anzahl der zweiten Schichtbilder (46) ist.

3. Verfahren nach einem der vorhergehenden Ansprüche, wobei für jedes Schichtbild (34, 46) eine Vielzahl von A-Scans des Objekts aufgezeichnet wird, wobei die Anzahl der A-Scans für die ersten Schichtbilder (34) in jedem Fall kleiner als für die zweiten Schichtbilder (46) ist, und/oder wobei die ersten Schichtbilder (34) mittels B-Scans aufgezeichnet werden, die in einem regelmäßigen Muster (35) über das Objekt (12) verteilt sind, und/oder wobei die ersten Schichtbilder (34) mittels B-Scans aufgezeichnet werden, die in einem Kreuzrastermuster (35) verteilt sind.

4. Verfahren nach einem der vorhergehenden Ansprüche, wobei die ersten Schichtbilder (34) in einem solchen Verteilungsmuster (35) aufgezeichnet werden, dass Punkte der Kreuzung der ersten Schichtbilder (34) mit der Referenzfigur (44) im Wesentlichen in gleichen Abständen entlang der Referenzfigur (44) verteilt verortet sind, und/oder dass die Anzahl n der Punkte der Kreuzung, bei der die Referenzfigur (44) die ersten Schichtbilder (34) kreuzt, in jedem Fall in einem Winkel innerhalb des Bereichs von mehr als 30° und weniger als 60° in Bezug zu der Oberflächennormale des jeweiligen Schichtbildes mindestens $2(N-2)$ ergibt, wobei N die Anzahl der ersten Schichtbilder (34) ist, und/oder dass die Anzahl n der Punkte der Kreuzung, bei denen die Referenzfigur (44) die ersten Schichtbilder (36) kreuzt, ausreicht, um die Geometrie der Referenzfigur (44) zu beschreiben, nachdem die Referenzfigur (44) an die ersten Schichtbilder (34) adaptiert worden ist.

5. Verfahren nach einem der vorhergehenden Ansprüche, wobei die zweiten Schichtbilder (46) mittels B-Scans aufgezeichnet werden, die in einem unregelmäßigen Muster (45) über das Objekt (12) verteilt sind. 5
6. Verfahren nach Anspruch 5, wobei das unregelmäßige Muster (45) ein Kreuzrastermuster einschließt, dessen Rasterliniendichte in einer Zentralregion (47a) der Referenzfigur (44) niedriger als in einer Region (47b) der Referenzfigur (44) entfernt von dem Zentrum ist, und/oder wobei das unregelmäßige Muster (45) mindestens zwei Kreuzrastermuster einschließt, die übereinander winkelfersetzt platziert sind, wodurch insbesondere das Muster zwei übereinander mit einem Winkel von etwa 45° winkelfersetzt platzierte Kreuzrastermuster einschließt, oder drei übereinander mit einem Winkel von etwa 60° winkelfersetzt platzierte Kreuzrastermuster einschließt. 10
7. Verfahren nach einem der vorhergehenden Ansprüche, wobei das Ermitteln der Referenzfigur (44) Adaptieren mindestens einer kreisförmigen Figur an Merkmalspositionen (42) des mindestens einen Strukturmerkmals (36) in den ersten Schichtbildern (34) einschließt, und/oder wobei das Objekt (12) ein menschliches Auge ist und das mindestens eine Strukturmerkmal (36) einen inneren Irisrandsaum und/oder einen äußeren Irisrandsaum des Auges und/oder einen Limbus des Auges einschließt. 25
8. Apparat (10) für optische Kohärenztomographie, umfassend eine OCT-Bilderfassungseinheit (33) und eine Computeranordnung (30), die für folgendes eingerichtet ist: 30
- Steuern der OCT-Bilderfassungseinheit (33) in einer solchen Weise, dass die OCT-Bilderfassungseinheit (33) eine Vielzahl von ersten OCT-Schichtbildern (34) aufzeichnet, wobei jedes erste Schichtbild (34) eine andere Schicht eines Objekts (12) repräsentiert, 40
 - Ermitteln einer Referenzfigur (44), die repräsentativ für die dreidimensionale Kontur des mindestens einen Strukturmerkmals (36) des Objekts (12) in einem gegebenen dreidimensionalen Koordinatensystem (x, y, z) ist, durch Merkmalerkennung des mindestens einen Strukturmerkmals (36) in jedem der ersten Schichtbilder (34), 45
 - Steuern der OCT-Bilderfassungseinheit (33) in einer solchen Weise, dass die OCT-Bilderfassungseinheit (33) eine Vielzahl von zweiten OCT-Schichtbildern (46) aufzeichnet, wobei jedes zweite Schichtbild (46) eine andere Schicht des Objekts (12) repräsentiert, wobei die OCT-Bilderfassungseinheit (33) eingerichtet ist, um 50
- während eines ersten Zeitraums ein erstes Schichtbild (34) und während eines zweiten Zeitraums ein zweites Schichtbild (46) aufzuzeichnen, wobei der erste Zeitraum kürzer als der zweite Zeitraum ist,
- Verschieben mindestens einer Fraktion der zweiten Schichtbilder (46) in dem Koordinatensystem (x, y, z), bis jedes zweite Schichtbild (46) in Merkmalsüberlappung mit der Referenzfigur (44) ist, und
 - Generieren eines Satzes von dreidimensionalen OCT-Bilddaten mindestens aus den merkmalsüberlappenden zweiten Schichtbildern (46).
9. Apparat (10) nach Anspruch 8, wobei die OCT-Bilderfassungseinheit (33) eingerichtet ist, um eine Anzahl von ersten Schichtbildern (34) und eine Anzahl von zweiten Schichtbildern (46) aufzuzeichnen, wobei die Anzahl der ersten Schichtbilder (34) kleiner als die Anzahl der zweiten Schichtbilder (46) ist. 55
10. Apparat (10) nach einem der Ansprüche 8 oder 9, wobei die OCT-Bilderfassungseinheit (33) eingerichtet ist, um für jedes Schichtbild (34, 46) eine Vielzahl von A-Scans des Objekts aufzuzeichnen, wobei die Anzahl der A-Scans für die ersten Schichtbilder (34) in jedem Fall kleiner als für die zweiten Schichtbilder (46) ist, und/oder wobei die OCT-Bilderfassungseinheit (33) eingerichtet ist, um die ersten Schichtbilder (34) mittels B-Scans aufzuzeichnen, die in einem regelmäßigen Muster (35) über das Objekt (12) verteilt sind, und/oder wobei die OCT-Bilderfassungseinheit (33) eingerichtet ist, um die ersten Schichtbilder (34) mittels B-Scans aufzuzeichnen, die in einem Kreuzrastermuster (35) verteilt sind. 60
11. Apparat (10) nach einem der Ansprüche 8 bis 10, wobei die OCT-Bilderfassungseinheit (33) eingerichtet ist, um die ersten Schichtbilder (34) in einem solchen Verteilungsmuster (35) aufzuzeichnen, dass Punkte der Kreuzung der ersten Schichtbilder (34) mit der Referenzfigur (44) im Wesentlichen in gleichen Abständen entlang der Referenzfigur (44) verteilt verortet sind, und/oder dass die Anzahl n der Punkte der Kreuzung, bei der die Referenzfigur (44) die ersten Schichtbilder (34) kreuzt, in jedem Fall in einem Winkel innerhalb des Bereichs von mehr als 30° und weniger als 60° in Bezug zu den Oberflächennormalen des jeweiligen Schichtbildes mindestens $2(N-2)$ ergibt, wobei N die Anzahl der ersten Schichtbilder (34) ist, und/oder dass die Anzahl n der Punkte der Kreuzung, bei denen die Referenzfigur (44) die ersten Schichtbilder (34) kreuzt, ausreicht, um die Geometrie der Referenzfigur (44) zu beschreiben, nachdem die Referenzfigur (44) an die ersten Schichtbilder (34) adaptiert worden ist. 65

12. Apparat (10) nach einem der Ansprüche 8 bis 11, wobei die OCT-Bilderfassungseinheit (33) eingerichtet ist, um die zweiten Schichtbilder (46) mittels B-Scans aufzuzeichnen, die in einem unregelmäßigen Muster (45) über das Objekt (12) verteilt sind. 5
13. Apparat (10) nach Anspruch 12, wobei die OCT-Bilderfassungseinheit (33) eingerichtet ist, um die zweiten Schichtbilder (46) gemäß dem unregelmäßigen Muster (45) aufzuzeichnen, wobei das unregelmäßige Muster (45) ein Kreuzrastermuster einschließt, dessen Rasterliniendichte in einer Zentralregion (47a) der Referenzfigur (44) niedriger als in einer Region (47b) der Referenzfigur (44) entfernt von dem Zentrum ist, und/oder wobei die OCT-Bilderfassungseinheit (33) eingerichtet ist, um die zweiten Schichtbilder (46) gemäß dem unregelmäßigen Muster (45) aufzuzeichnen, wobei das unregelmäßige Muster (45) mindestens zwei Kreuzrastermuster einschließt, die übereinander winkelfersetzt platziert sind, wodurch insbesondere das Muster zwei übereinander mit einem Winkel von etwa 45° winkelfersetzt platzierte Kreuzrastermuster einschließt, oder drei übereinander mit einem Winkel von etwa 60° winkelfersetzt platzierte Kreuzrastermuster einschließt. 10 15 20 25
14. Apparat (10) nach einem der Ansprüche 8 bis 13, wobei die Computeranordnung eingerichtet ist, um die Referenzfigur (44) durch Adaptieren mindestens einer kreisförmigen Figur an Merkmalspositionen (42) des mindestens einen Strukturmerkmals (36) in den ersten Schichtbildern (34) zu ermitteln, und/oder wobei das Objekt (12) ein menschliches Auge ist und das mindestens eine Strukturmerkmal (36) einen inneren Irisrandsaum und/oder einen äußeren Irisrandsaum des Auges und/oder einen Limbus des Auges einschließt. 30 35

Revendications

1. Procédé de tomographie en cohérence optique, comprenant les étapes suivantes :
- enregistrer une pluralité de premières images de tranches OCT (34), chaque première image de tranche (34) représentant une tranche différente d'un objet (12),
 - vérifier une figure de référence (44) qui est représentative du contour tridimensionnel d'au moins une caractéristique structurale (36) de l'objet (12) dans un système de coordonnées tridimensionnel donné (x, y, z) par reconnaissance de caractéristique de l'au moins une caractéristique structurale (36) dans chacune des premières images de tranches (34),
 - enregistrer une pluralité de deuxièmes images

de tranches OCT (46), chaque deuxième image de tranche (46) représentant une tranche différente de l'objet (12), un laps de temps nécessaire pour l'enregistrement d'une première image de tranche (34) étant plus court qu'un laps de temps nécessaire pour l'enregistrement d'une deuxième image de tranche (46),

- déplacer au moins une fraction des deuxièmes images de tranches (46) dans le système de coordonnées (x, y, z) jusqu'à ce que chaque deuxième image de tranche (46) soit en chevauchement de caractéristique avec la figure de référence (44), et
- générer un ensemble de données d'image OCT tridimensionnelles au moins à partir des deuxièmes images de tranches en chevauchement de caractéristique (46).

2. Procédé selon la revendication 1, dans lequel le nombre de premières images de tranches (34) est inférieur au nombre de deuxièmes images de tranches (46).
3. Procédé selon une des revendications précédentes, dans lequel pour chaque image de tranche (34, 46), une pluralité de balayages A de l'objet sont enregistrés, le nombre de balayages A pour les premières images de tranches (34) étant dans chaque cas inférieur à celui pour les deuxièmes images de tranches (46), et/ou dans lequel les premières images de tranches (34) sont enregistrées au moyen de balayages B qui sont répartis sur l'objet (12) en un motif régulier (35), et/ou dans lequel les premières images de tranches (34) sont enregistrées au moyen de balayages B qui sont répartis en un motif de quadrillage (35).
4. Procédé selon une des revendications précédentes, dans lequel les premières images de tranches (34) sont enregistrées selon un motif de répartition (35) tel que des points d'intersection des premières images de tranches (34) avec la figure de référence (44) sont situés, répartis avec des espacements sensiblement égaux, le long de la figure de référence (44) et/ou que le nombre n de points d'intersection auxquels la figure de référence (44) coupe les premières images de tranches (34) dans chaque cas à un angle dans la gamme de plus de 30° et moins de 60° par rapport à la normale à la surface de l'image de tranche respective s'élève à au moins 2(N-2), où N est le nombre de premières images de tranches (34), et/ou que le nombre n de points d'intersection auxquels la figure de référence (44) coupe les premières images de tranches (36) suffit pour décrire la géométrie de la figure de référence (44) après que la figure de référence (44) a été adaptée aux premières images de tranches (34). 40 45 50 55

5. Procédé selon une des revendications précédentes, dans lequel les deuxièmes images de tranches (46) sont enregistrées au moyen de balayages B qui sont répartis sur l'objet (12) en un motif irrégulier (45).
6. Procédé selon la revendication 5, dans lequel le motif irrégulier (45) comporte un motif de quadrillage, dont la densité de lignes de quadrillage dans une région centrale (47a) de la figure de référence (44) est plus faible que dans une région (47b) de la figure de référence (44) éloignée du centre, et/ou dans lequel le motif irrégulier (45) comporte au moins deux motifs de quadrillage placés l'un au-dessus de l'autre en décalage angulaire, moyennant quoi en particulier le motif comporte deux motifs de quadrillage placés l'un au-dessus de l'autre en décalage angulaire avec un angle d'environ 45° ou comporte trois motifs de quadrillage placés les uns au-dessus des autres en décalage angulaire avec un angle d'environ 60°.
7. Procédé selon une des revendications précédentes, dans lequel la vérification de la figure de référence (44) comporte une adaptation d'au moins une figure circulaire à des positions de caractéristique (42) de l'au moins une caractéristique structurale (36) dans les premières images de tranches (34), et/ou dans lequel l'objet (12) est un oeil humain et l'au moins une caractéristique structurale (36) comporte une marge intérieure d'iris et/ou une marge extérieure d'iris de l'oeil et/ou un limbe de l'oeil.
8. Appareil (10) de tomographie en cohérence optique, comprenant une unité d'acquisition d'images OCT (33) et un agencement informatique (30) qui a été configuré
- pour contrôler l'unité d'acquisition d'images OCT (33) de manière à ce que l'unité d'acquisition d'images OCT (33) enregistre une pluralité de premières images de tranches OCT (34), chaque première image de tranche (34) représentant une tranche différente d'un objet (12),
 - pour vérifier une figure de référence (44) qui est représentative du contour tridimensionnel d'au moins une caractéristique structurale (36) de l'objet (12) dans un système de coordonnées tridimensionnel donné (x, y, z) par reconnaissance de caractéristique de l'au moins une caractéristique structurale (36) dans chacune des premières images de tranches (34),
 - pour contrôler l'unité d'acquisition d'images OCT (33) de manière à ce que l'unité d'acquisition d'images OCT (33) enregistre une pluralité de deuxièmes images de tranches OCT (46), chaque deuxième image de tranche (46) représentant une tranche différente de l'objet (12), l'unité d'acquisition d'images OCT (33) ayant été configurée pour enregistrer une première image de tranche (34) pendant un premier laps de temps et une deuxième image de tranche (46) pendant un deuxième laps de temps, le premier laps de temps étant plus court que le deuxième laps de temps,
 - pour déplacer au moins une fraction des deuxièmes images de tranches (46) dans le système de coordonnées (x, y, z) jusqu'à ce que chaque deuxième image de tranche (46) soit en chevauchement de caractéristique avec la figure de référence (44), et
 - pour générer un ensemble de données d'image OCT tridimensionnelles au moins à partir des deuxièmes images de tranches en chevauchement de caractéristique (46).
9. Appareil (10) selon la revendication 8, dans lequel l'unité d'acquisition d'images OCT (33) a été configurée pour enregistrer un nombre de premières images de tranches (34) et un nombre de deuxièmes images de tranches (46), le nombre de premières images de tranches (34) étant inférieur au nombre de deuxièmes images de tranches (46).
10. Appareil (10) selon une des revendications 8 ou 9, dans lequel l'unité d'acquisition d'images OCT (33) a été configurée pour enregistrer pour chaque image de tranche (34, 46) une pluralité de balayages A de l'objet, le nombre de balayages A pour les premières images de tranches (34) étant dans chaque cas inférieur à celui pour les deuxièmes images de tranches (46), et/ou dans lequel l'unité d'acquisition d'images OCT (33) a été configurée pour enregistrer les premières images de tranches (34) au moyen de balayages B qui sont répartis sur l'objet (12) en un motif régulier (35), et/ou dans lequel l'unité d'acquisition d'images OCT (33) a été configurée pour enregistrer les premières images de tranches (34) au moyen de balayages B qui sont répartis en un motif de quadrillage (35).
11. Appareil (10) selon une des revendications 8 à 10, dans lequel l'unité d'acquisition d'images OCT (33) a été configurée pour enregistrer les premières images de tranches (34) selon un motif de répartition (35) tel que des points d'intersection des premières images de tranches (34) avec la figure de référence (44) sont situés, répartis avec des espacements sensiblement égaux, le long de la figure de référence (44) et/ou que le nombre n de points d'intersection auxquels la figure de référence (44) coupe les premières images de tranches (34) dans chaque cas à un angle dans la gamme de plus de 30° et moins de 60° par rapport à la normale à la surface de l'image de tranche respective s'élève à au moins 2(N-2), où N est le nombre de premières images de tranches (34), et/ou que le nombre n de points d'intersection auxquels la figure de référence (44) coupe les pre-

mières images de tranches (34) suffit pour décrire la géométrie de la figure de référence (44) après que la figure de référence (44) a été adaptée aux premières images de tranches (34).

5

- 12.** Appareil (10) selon une des revendications 8 à 11, dans lequel l'unité d'acquisition d'images OCT (33) a été configurée pour enregistrer les deuxièmes images de tranches (46) au moyen de balayages B qui sont répartis sur l'objet (12) en un motif irrégulier (45).

10

- 13.** Appareil (10) selon la revendication 12, dans lequel l'unité d'acquisition d'images OCT (33) a été configurée pour enregistrer les deuxièmes images de tranches (46) selon le motif irrégulier (45), le motif irrégulier (45) comportant un motif de quadrillage, dont la densité de lignes de quadrillage dans une région centrale (47a) de la figure de référence (44) est plus faible que dans une région (47b) de la figure de référence (44) éloignée du centre, et/ou dans lequel l'unité d'acquisition d'images OCT (33) a été configurée pour enregistrer les deuxièmes images de tranches (46) selon le motif irrégulier (45), le motif irrégulier (45) comportant au moins deux motifs de quadrillage placés l'un au-dessus de l'autre en décalage angulaire, moyennant quoi en particulier le motif comporte deux motifs de quadrillage placés l'un au-dessus de l'autre en décalage angulaire avec un angle d'environ 45° ou comporte trois motifs de quadrillage placés les uns au-dessus des autres en décalage angulaire avec un angle d'environ 60°.

15

20

25

30

- 14.** Appareil (10) selon une des revendications 8 à 13, dans lequel l'agencement informatique a été configuré pour vérifier la figure de référence (44) par une adaptation d'au moins une figure circulaire à des positions de caractéristique (42) de l'au moins une caractéristique structurale (36) dans les premières images de tranches (34), et/ou dans lequel l'objet (12) est un oeil humain et l'au moins une caractéristique structurale (36) comporte une marge intérieure d'iris et/ou une marge extérieure d'iris de l'oeil et/ou un limbe de l'oeil.

35

40

45

50

55

FIG 1

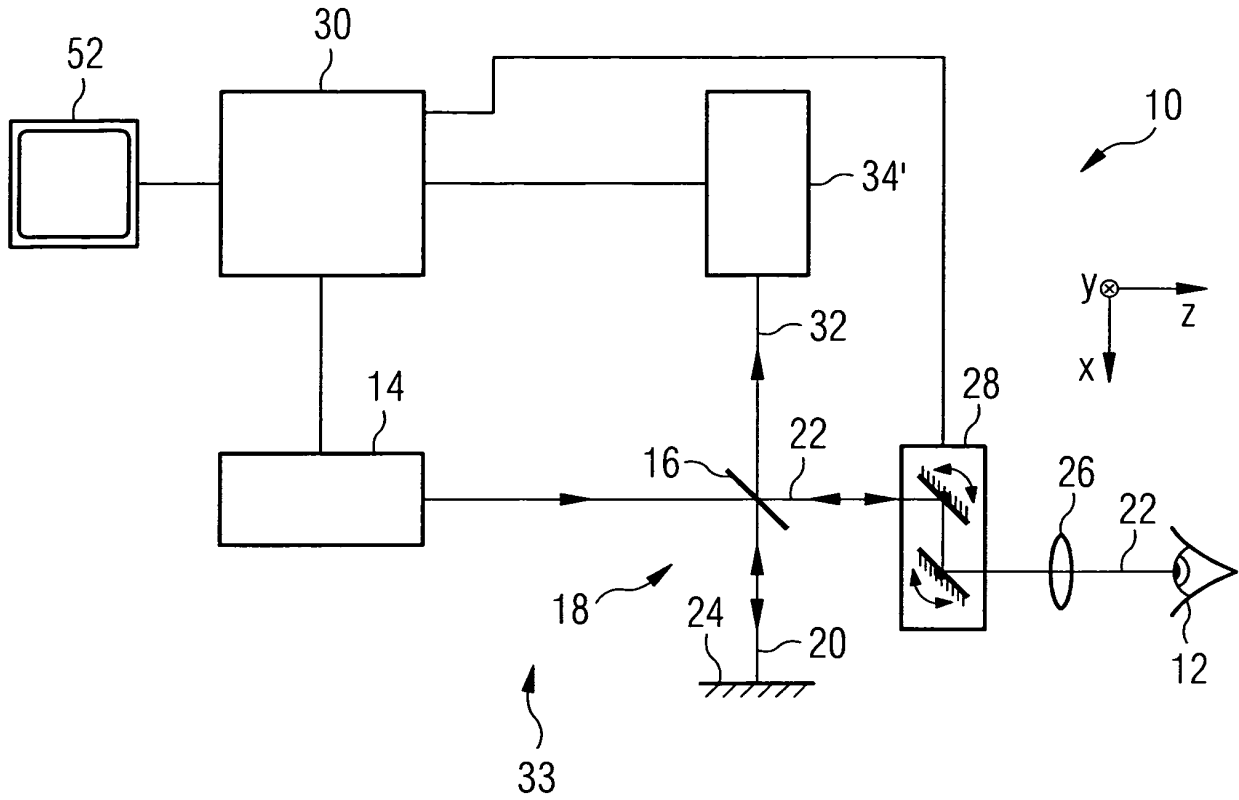

FIG 2

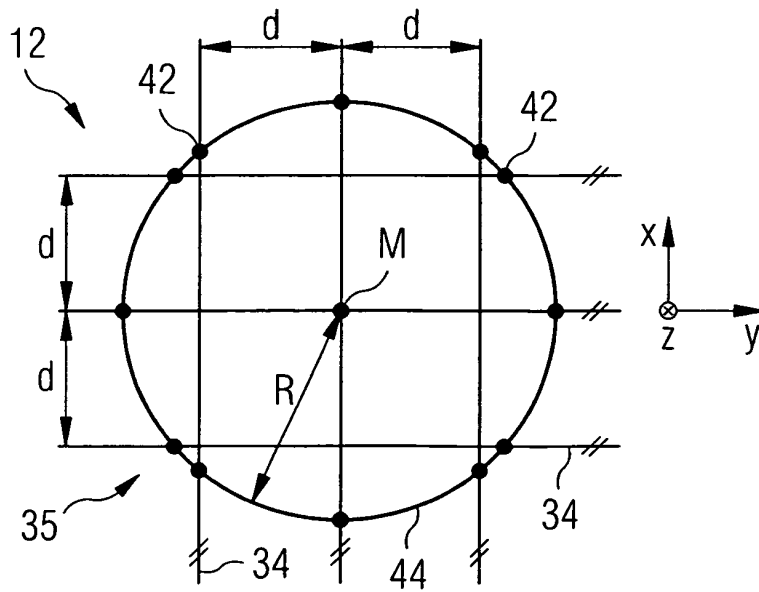

FIG 3

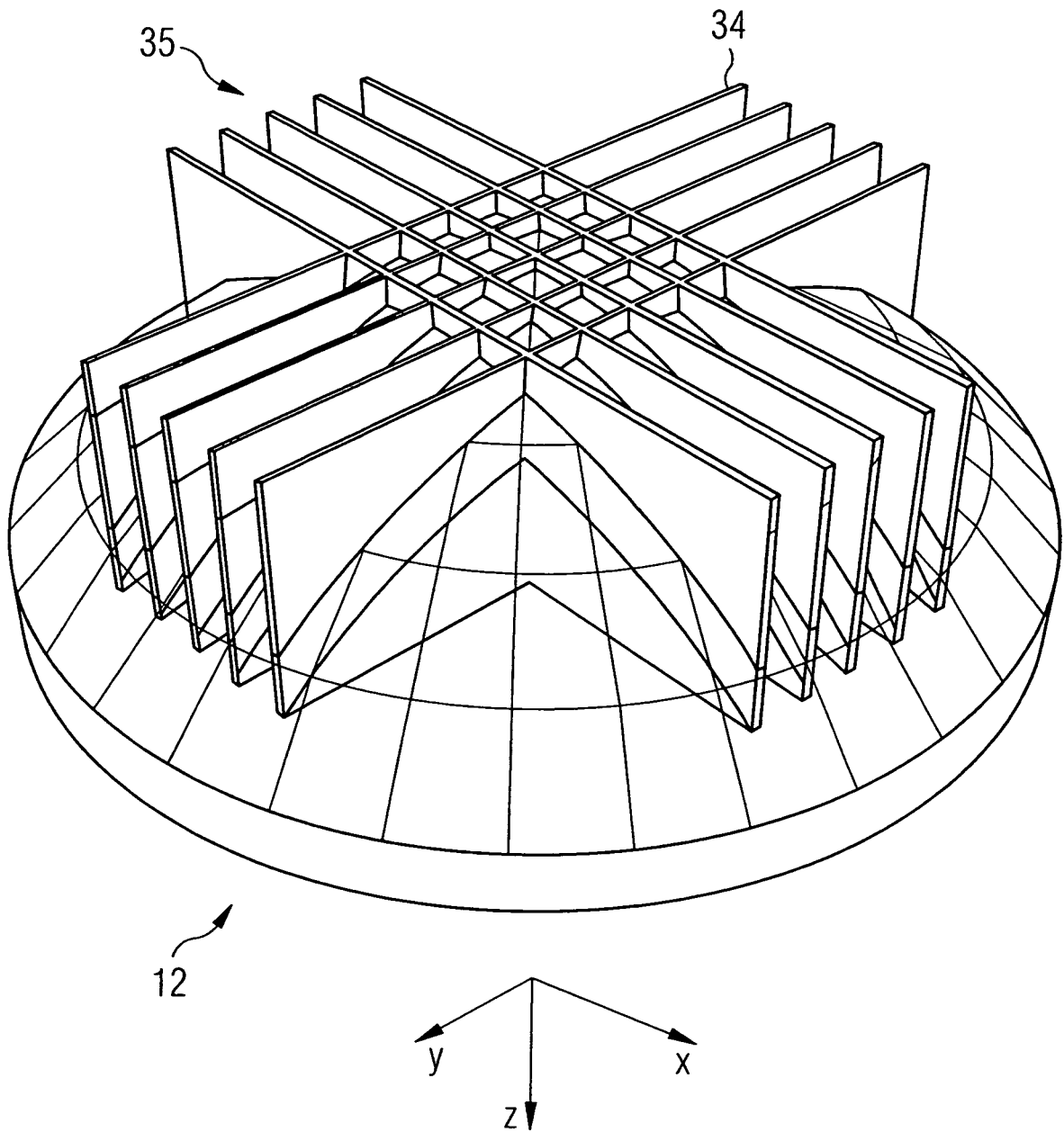

FIG 4a

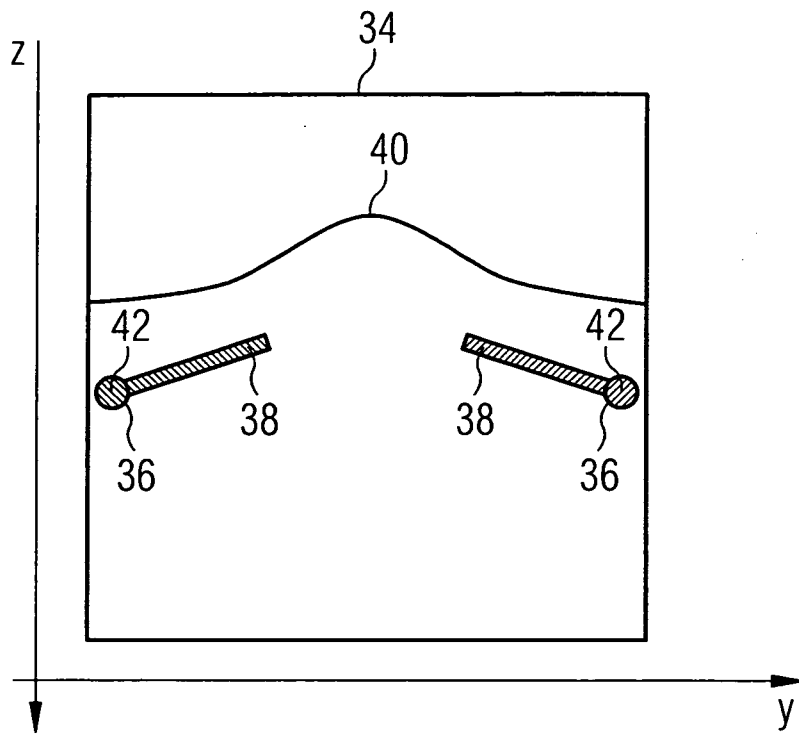

FIG 4b

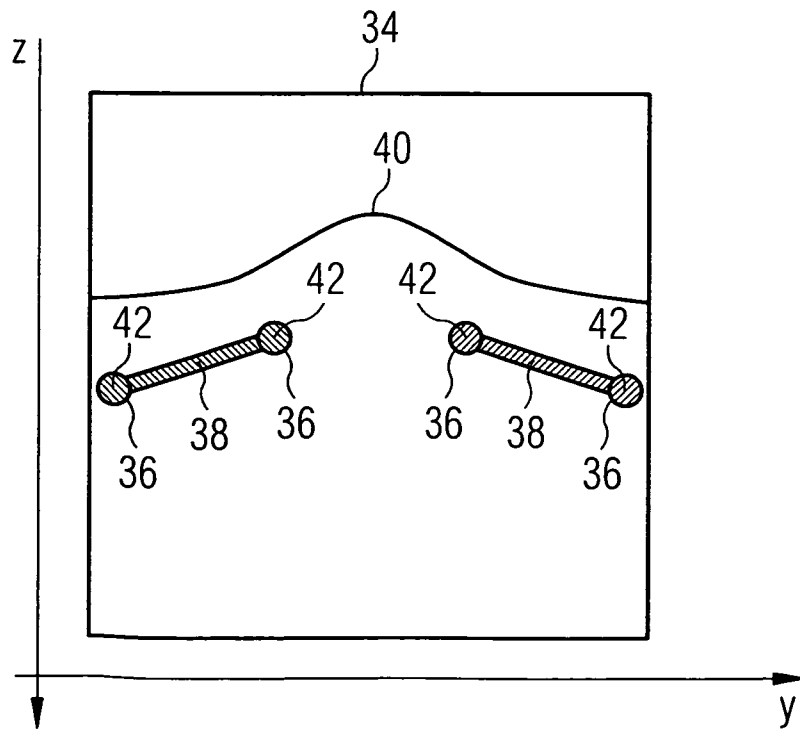

FIG 5

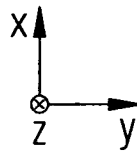
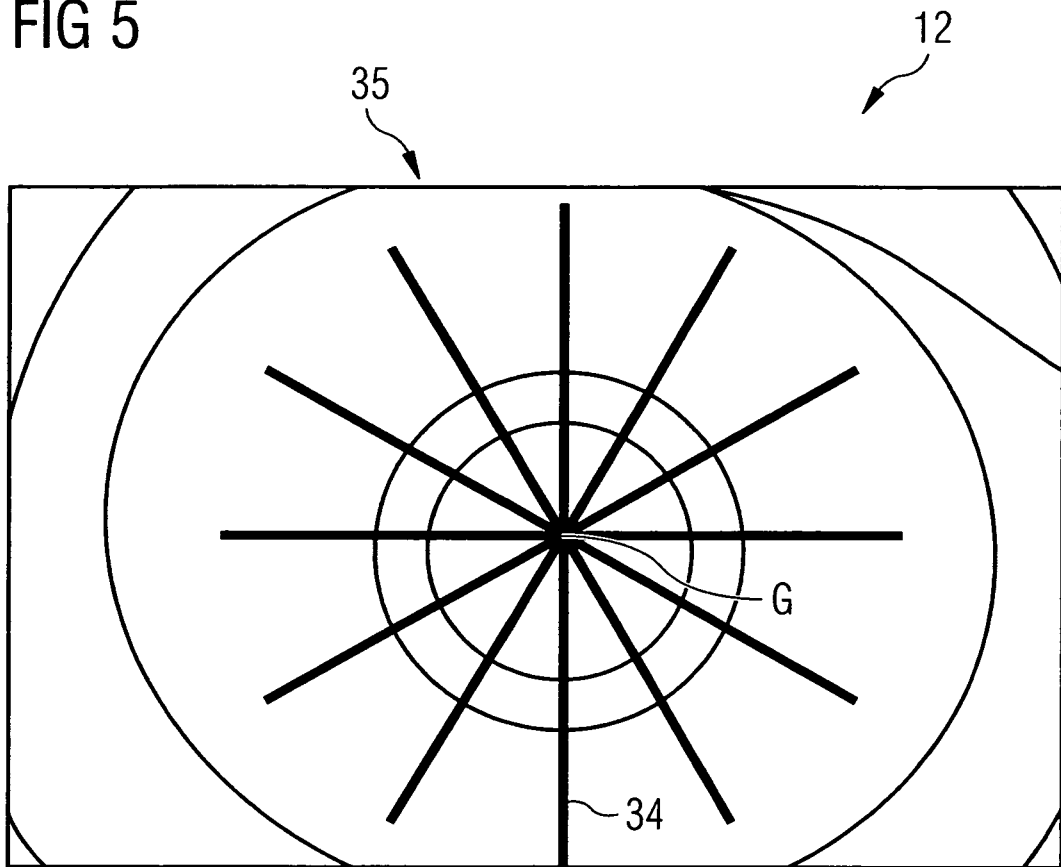

FIG 6a

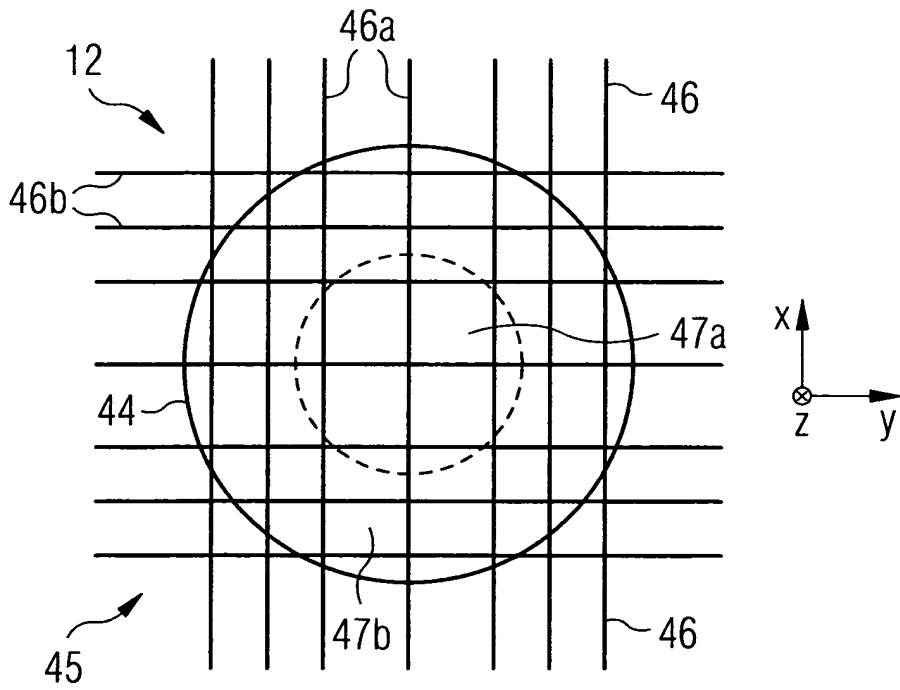

FIG 6b

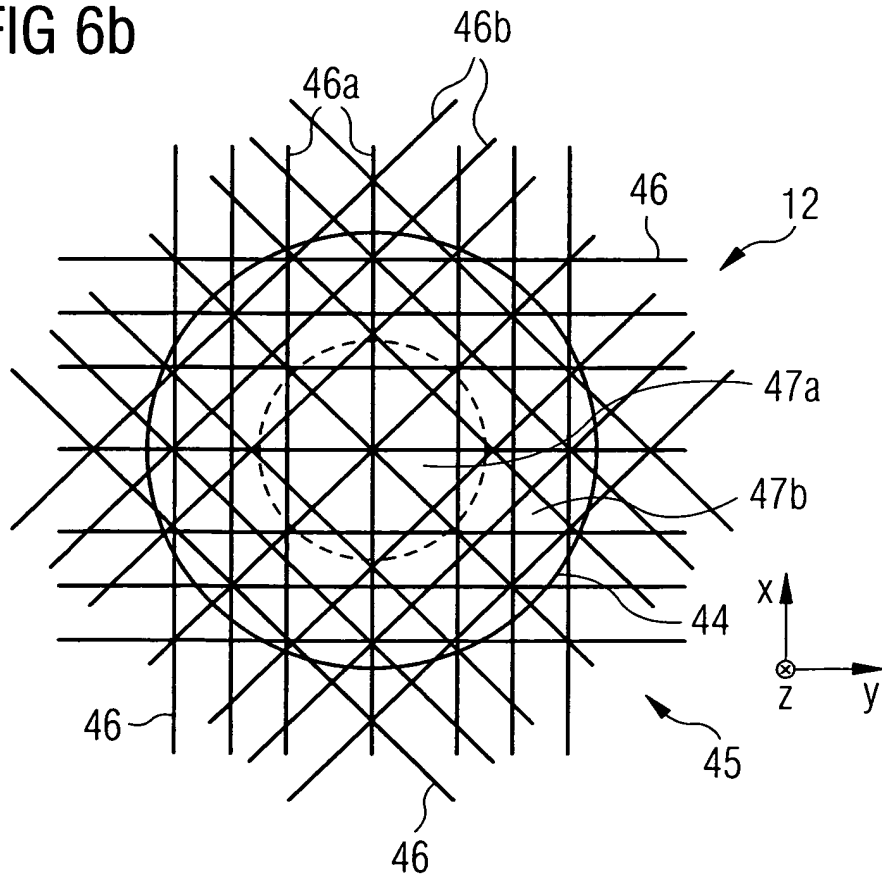

FIG 7a

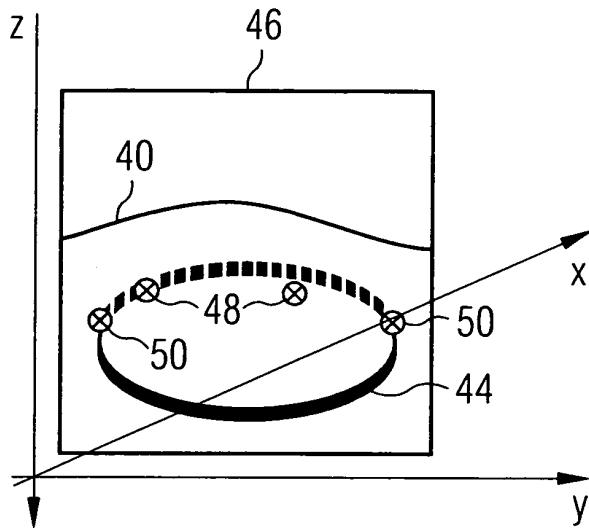

FIG 7b

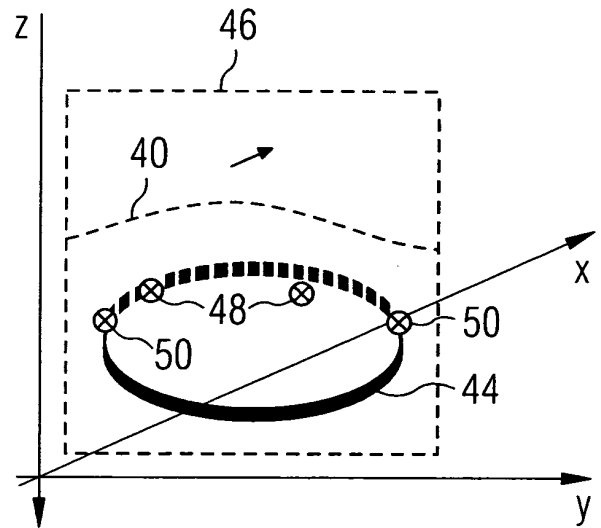

FIG 7c

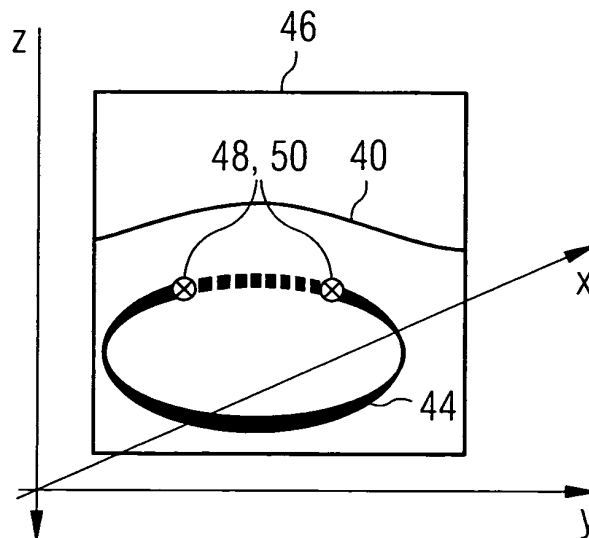

FIG 8a

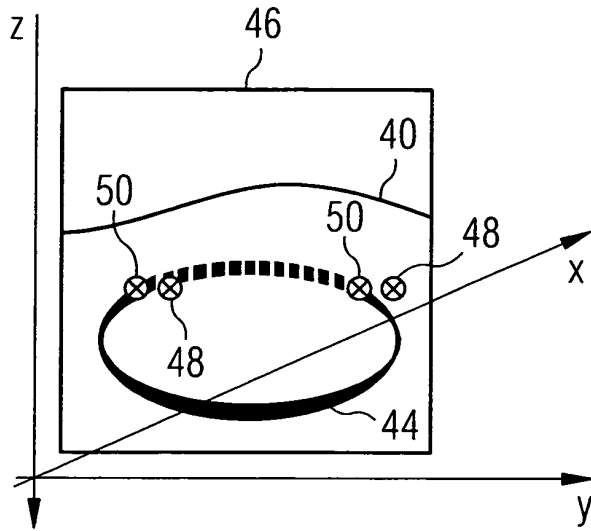

FIG 8b

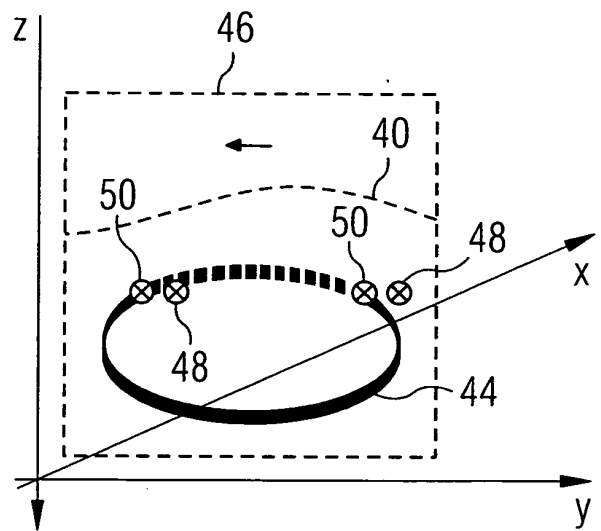

FIG 8c

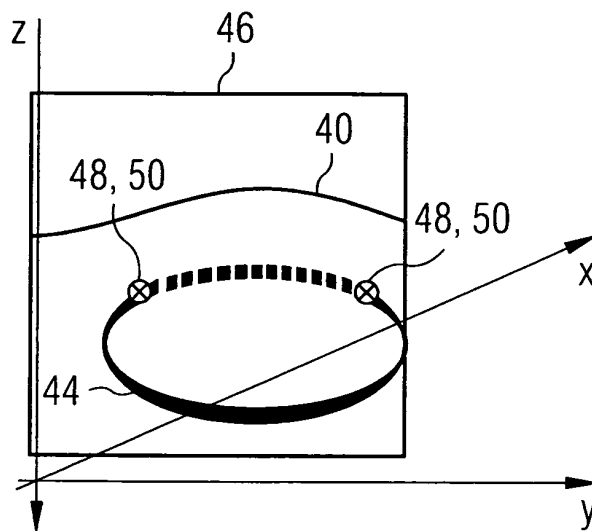

FIG 9a

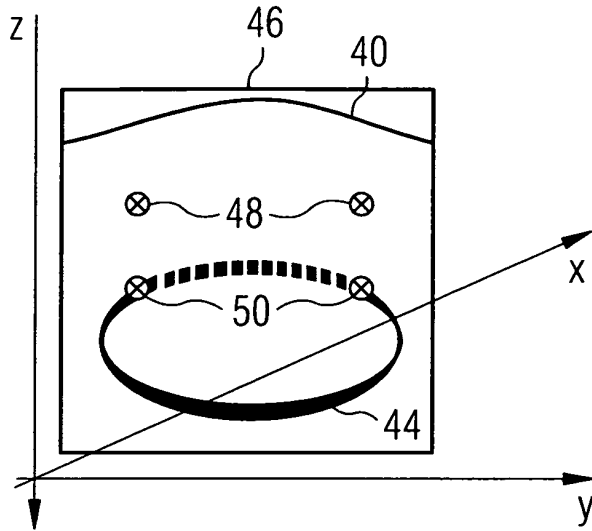

FIG 9b

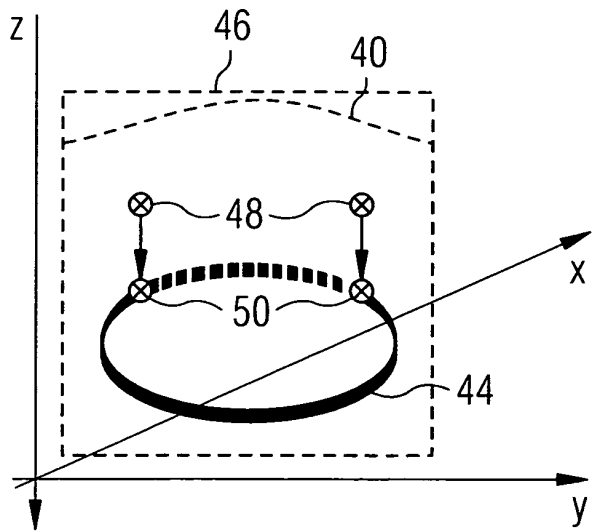

FIG 9c

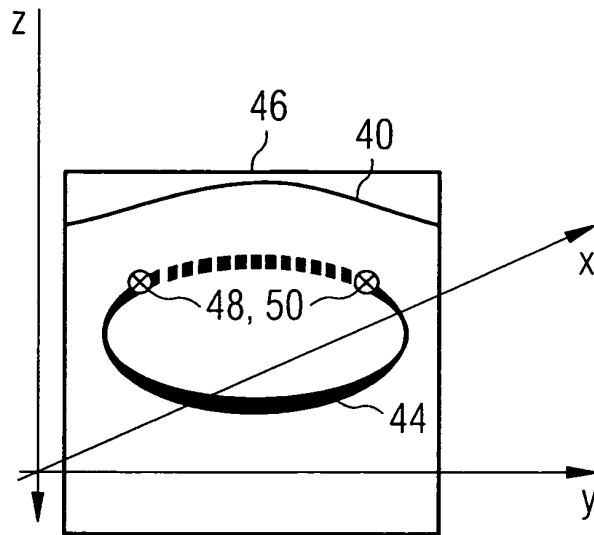

FIG 10a

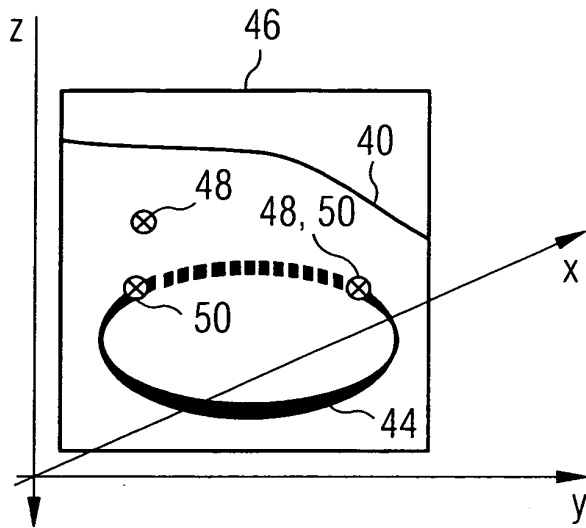

FIG 10b

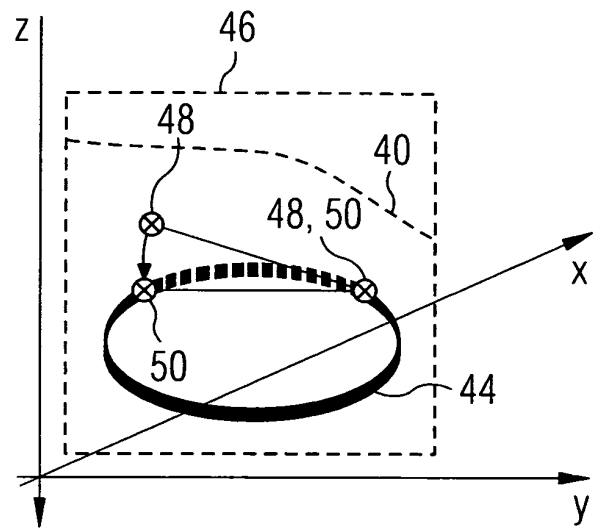

FIG 10c

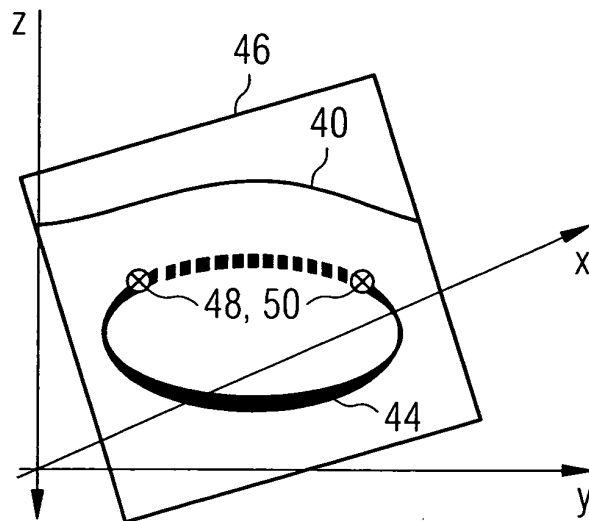

FIG 11a

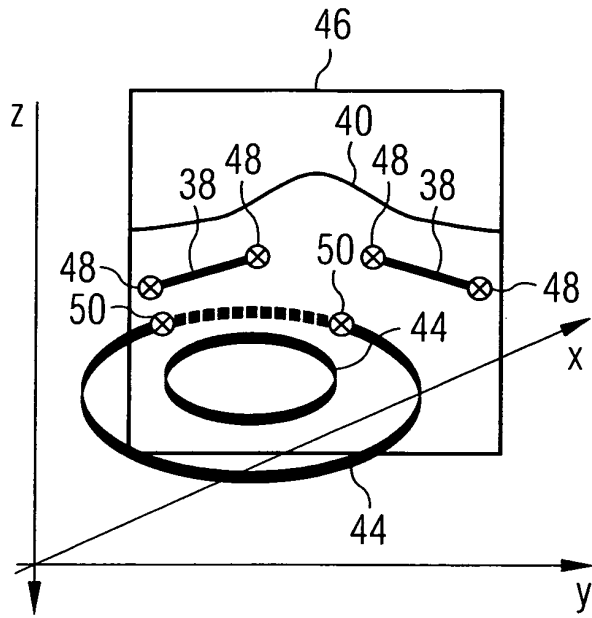

FIG 11b

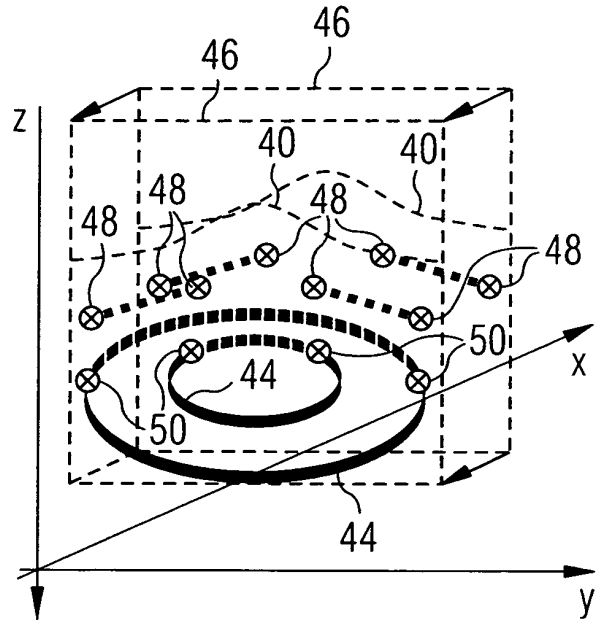

FIG 11c

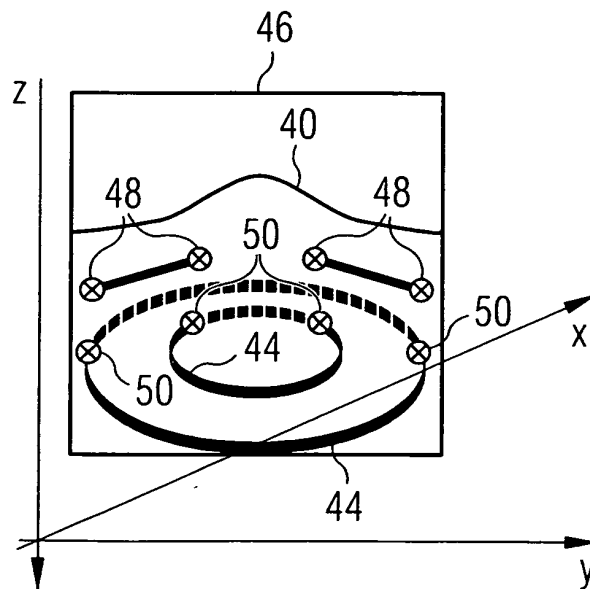

FIG 11d

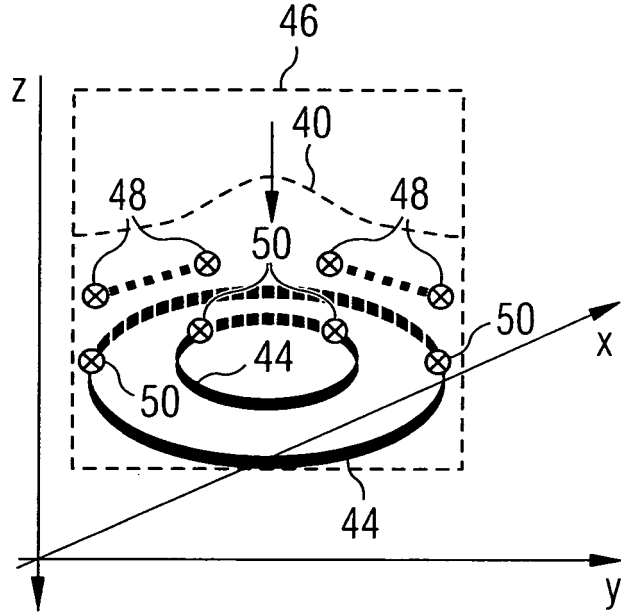
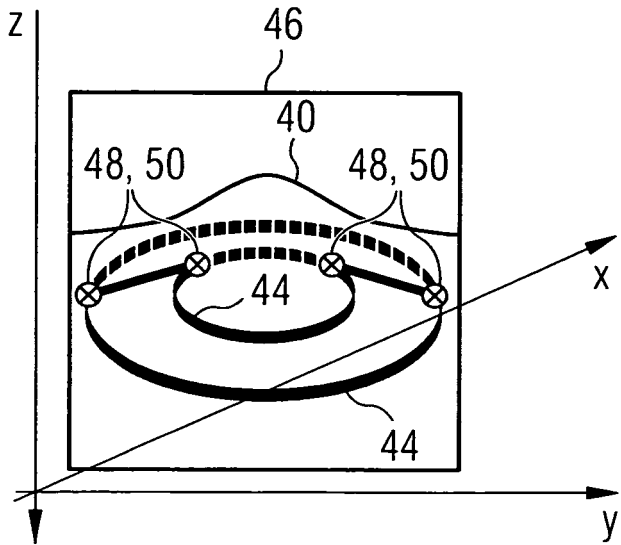

FIG 11e



REFERENCES CITED IN THE DESCRIPTION

This list of references cited by the applicant is for the reader's convenience only. It does not form part of the European patent document. Even though great care has been taken in compiling the references, errors or omissions cannot be excluded and the EPO disclaims all liability in this regard.

Patent documents cited in the description

- US 20080100612 A1 [0004]
- US 20110134394 A1 [0005]
- WO 2010117386 A1 [0005]

专利名称(译)	用于光学相干断层扫描的方法和用于光学相干断层扫描的设备		
公开(公告)号	EP2797493A1	公开(公告)日	2014-11-05
申请号	EP2011804967	申请日	2011-12-28
[标]申请(专利权)人(译)	波光股份有限公司		
申请(专利权)人(译)	鹰视GMBH		
当前申请(专利权)人(译)	鹰视GMBH		
[标]发明人	MASSOW OLE WISWEH HENNING JEGLORZ TOBIAS		
发明人	MASSOW, OLE WISWEH, HENNING JEGLORZ, TOBIAS		
IPC分类号	A61B3/10 A61B3/00 G06T7/00 A61B5/00 G06K9/62		
其他公开文献	EP2797493B1		
外部链接	Espacenet		

摘要(译)

在用于光学相干断层摄影的过程中，记录表示对象的不同切片的每个第一切片图像中的多个第一OCT切片图像。随后，通过第一切片图像中的至少一个结构特征的特征识别来确定表示给定三维坐标系中的对象的至少一个结构特征的三维轮廓的参考图。然后记录多个第二OCT切片图像，每个第二切片图像表示对象的不同切片。至少一部分第二切片图像在坐标系中移位，直到每个第二切片图像与参考图形特征重叠。最后，至少从特征重叠的第二切片图像生成一组三维OCT图像数据。