



(11) **EP 2 280 636 B1**

(12) **EUROPEAN PATENT SPECIFICATION**

(45) Date of publication and mention of the grant of the patent:
30.11.2016 Bulletin 2016/48

(21) Application number: **09755752.4**

(22) Date of filing: **28.05.2009**

(51) Int Cl.:
A61B 5/00 (2006.01)

(86) International application number:
PCT/US2009/045545

(87) International publication number:
WO 2009/146391 (03.12.2009 Gazette 2009/49)

(54) **CLOSE PROXIMITY COMMUNICATION DEVICE AND METHODS**

NÄHERUNGSKOMMUNIKATIONSVORRICHTUNG UND -VERFAHREN

DISPOSITIF ET PROCÉDÉS DE COMMUNICATION RAPPROCHÉS

(84) Designated Contracting States:
AT BE BG CH CY CZ DE DK EE ES FI FR GB GR HR HU IE IS IT LI LT LU LV MC MK MT NL NO PL PT RO SE SI SK TR

(30) Priority: **30.05.2008 US 130995**

(43) Date of publication of application:
09.02.2011 Bulletin 2011/06

(73) Proprietor: **Abbott Diabetes Care Inc.**
Alameda, CA 94502 (US)

(72) Inventors:
• **SICURELLO, Jeffrey**
Union City
CA 94587 (US)
• **SLOAN, Mark, K.**
Redwood City
CA 94065 (US)

(74) Representative: **Kazi, Ilya et al**
Mathys & Squire LLP
The Shard
32 London Bridge Street
London SE1 9SG (GB)

(56) References cited:
WO-A2-2006/064397 WO-A2-2008/138006
CA-A1- 2 605 530 US-A1- 2005 182 306
US-A1- 2006 293 607 US-A1- 2007 232 880

- **RODRIGUEZ N ET AL: "Flexible Communication and Control Protocol for Injectable Neuromuscular Interfaces", IEEE TRANSACTIONS ON BIOMEDICAL CIRCUITS AND SYSTEMS, IEEE, US, vol. 1, no. 1, 1 March 2007 (2007-03-01), pages 19-27, XP011184525, ISSN: 1932-4545, DOI: 10.1109/TBCAS.2007.893177**
- **Syed Ahson ET AL: "Layers of Security for Active RFID Tags" In: "RFID Handbook", 18 March 2008 (2008-03-18), CRC Press, XP55020083, ISBN: 978-1-42-005500-9 * Section 33.3.2.figure 33.5 ***

Note: Within nine months of the publication of the mention of the grant of the European patent in the European Patent Bulletin, any person may give notice to the European Patent Office of opposition to that patent, in accordance with the Implementing Regulations. Notice of opposition shall not be deemed to have been filed until the opposition fee has been paid. (Art. 99(1) European Patent Convention).

EP 2 280 636 B1

Description

PRIORITY

5 **[0001]** The present application claims priority to U.S. application no. 12/130,995 filed May 30, 2008, entitled "Close Proximity Communication Device and Methods", the disclosure of which is incorporated herein by reference for all purposes.

BACKGROUND

10 **[0002]** Analyte, e.g., glucose monitoring systems including continuous and discrete monitoring systems generally include a small, lightweight battery powered and microprocessor controlled system which is configured to detect signals proportional to the corresponding measured glucose levels using an electrometer. RF signals may be used to transmit the collected data. One aspect of certain analyte monitoring systems include a transcutaneous or subcutaneous analyte sensor configuration which is, for example, at least partially positioned through the skin layer of a subject whose analyte level is to be monitored. The sensor may use a two or three-electrode (work, reference and counter electrodes) configuration driven by a controlled potential (potentiostat) analog circuit connected through a contact system.

15 **[0003]** An analyte sensor may be configured so that a portion thereof is placed under the skin of the patient so as to contact analyte of the patient, and another portion or segment of the analyte sensor may be in communication with the transmitter unit. The transmitter unit may be configured to transmit the analyte levels detected by the sensor over a wireless communication link such as an RF (radio frequency) communication link to a receiver/monitor unit. The receiver/monitor unit may perform data analysis, among other functions, on the received analyte levels to generate information pertaining to the monitored analyte levels.

20 **[0004]** Transmission of control or command data over wireless communication link is often constrained to occur within a substantially short time duration. In turn, the time constraint in data communication imposes limits on the type and size of data that may be transmitted during the transmission time period.

[0005] In view of the foregoing, it would be desirable to have a method and apparatus for optimizing the RF communication link between two or more communication devices, for example, in a medical communication system.

25 **[0006]** Rodriguez N et al: Flexible Communication and Control Protocol for Injectable Neuromuscular Interfaces" IEEE TRANSACTIONS ON BIOMEDICAL CIRCUITS AND SYSTEMS, IEEE, US, vol. 1, no.1, 1 March 2007 (2007-03-01), pages 19-27, discloses a system based on injectable neuromuscular implants whose main goal is to restore the functional movement of paralyzed limbs. A communication and control architecture for initialising the implants is described.

[0007] WO 2008/138006 A2 discloses analyte monitoring systems and methods, and is in particular concerned with providing data communication in such medical systems.

30 **[0008]** CA 2 605 530 A1, WO 2006/064397 A2 and US 2006/293607 A1 describe bidirectional wireless communication protocols for implantable sensors. SUMMARY

[0009] Devices and methods for analyte monitoring, e.g., glucose monitoring, and/or therapy management system including, for example, medication infusion device are provided. Embodiments include transmitting information from a first location to a second, e.g., using a telemetry system such as RF telemetry. Systems herein include continuous analyte monitoring systems, discrete analyte monitoring system, and therapy management systems.

35 **[0010]** These and other objects, features and advantages of the present disclosure will become more fully apparent from the following detailed description of the embodiments, the appended claims and the accompanying drawings.

BRIEF DESCRIPTION OF THE DRAWINGS

40 **[0011]**

FIG. 1 illustrates a block diagram of a data monitoring and management system for practicing one or more embodiments of the present disclosure;

45 FIG. 2 is a block diagram of the transmitter unit of the data monitoring and management system shown in FIG. 1 in accordance with one embodiment of the present disclosure;

FIG. 3 is a block diagram of the receiver/monitor unit of the data monitoring and management system shown in FIG. 1 in accordance with one embodiment of the present disclosure;

50 FIG. 4 is a flowchart illustrating data packet procedure including rolling data for transmission in accordance with one embodiment of the present disclosure;

FIG. 5 is a flowchart illustrating data processing of the received data packet including the rolling data in accordance with one embodiment of the present disclosure;

55 FIG. 6 is a block diagram illustrating the sensor unit and the transmitter unit of the data monitoring and management

system of FIG. 1 in accordance with one embodiment of the present disclosure;

FIG. 7 is a flowchart illustrating data communication using close proximity commands in the data monitoring and management system of FIG. 1 in accordance with one embodiment of the present disclosure;

FIG. 8 is a flowchart illustrating the pairing or synchronization routine in the data monitoring and management system of FIG. 1 in accordance with one embodiment of the present disclosure;

FIG. 9 is a flowchart illustrating the pairing or synchronization routine in the data monitoring and management system of FIG. 1 in accordance with another embodiment of the present disclosure;

FIG. 10 is a flowchart illustrating the power supply determination in the data monitoring and management system of FIG. 1 in accordance with one embodiment of the present disclosure;

FIG. 11 is a flowchart illustrating close proximity command for RF communication control in the data monitoring and management system of FIG. 1 in accordance with one embodiment of the present disclosure;

FIG. 12 illustrates a data format of a close proximity data packet sent by a controller, for use in one or more embodiments of the present disclosure;

FIG. 13 is a block diagram representation of a close proximity detection logic of the transmitter unit 620 in one or more embodiments of the present disclosure; and

FIG. 14 is a flow chart illustrating close proximity detection logic in one or more embodiments of the present disclosure.

DETAILED DESCRIPTION

[0012] As summarized above and as described in further detail below, in accordance with the various embodiments of the present disclosure, there is provided a method and system for positioning a controller unit within a transmission range for close proximity communication, transmitting one or more predefined close proximity commands, and receiving a response packet in response to the transmitted one or more predefined close proximity commands.

[0013] FIG. 1 illustrates a data monitoring and management system such as, for example, analyte (e.g., glucose) monitoring system 100 in accordance with one embodiment of the present disclosure. The subject invention is further described primarily with respect to a glucose monitoring system for convenience and such description is in no way intended to limit the scope of the invention. It is to be understood that the analyte monitoring system may be configured to monitor a variety of analytes, e.g., lactate, and the like.

[0014] Analytes that may be monitored include, for example, acetyl choline, amylase, bilirubin, cholesterol, chorionic gonadotropin, creatine kinase (e.g., CK-MB), creatine, DNA, fructosamine, glucose, glutamine, growth hormones, hormones, ketones, lactate, peroxide, prostate-specific antigen, prothrombin, RNA, thyroid stimulating hormone, and troponin. The concentration of drugs, such as, for example, antibiotics (e.g., gentamicin, vancomycin, and the like), digitoxin, digoxin, drugs of abuse, theophylline, and warfarin, may also be monitored. More than one analyte may be monitored by a single system, e.g. a single analyte sensor.

[0015] The analyte monitoring system 100 includes a sensor unit 101, a transmitter unit 102 coupleable to the sensor unit 101, and a primary receiver unit 104 which is configured to communicate with the transmitter unit 102 via a bi-directional communication link 103. The primary receiver unit 104 may be further configured to transmit data to a data processing terminal 105 for evaluating the data received by the primary receiver unit 104. Moreover, the data processing terminal 105 in one embodiment may be configured to receive data directly from the transmitter unit 102 via a communication link which may optionally be configured for bi-directional communication. Accordingly, transmitter unit 102 and/or receiver unit 104 may include a transceiver.

[0016] Also shown in FIG. 1 is an optional secondary receiver unit 106 which is operatively coupled to the communication link and configured to receive data transmitted from the transmitter unit 102. Moreover, as shown in the Figure, the secondary receiver unit 106 is configured to communicate with the primary receiver unit 104 as well as the data processing terminal 105. Indeed, the secondary receiver unit 106 may be configured for bi-directional wireless communication with each or one of the primary receiver unit 104 and the data processing terminal 105. As discussed in further detail below, in one embodiment of the present disclosure, the secondary receiver unit 106 may be configured to include a limited number of functions and features as compared with the primary receiver unit 104. As such, the secondary receiver unit 106 may be configured substantially in a smaller compact housing or embodied in a device such as a wrist watch, pager, mobile phone, PDA, for example. Alternatively, the secondary receiver unit 106 may be configured with the same or substantially similar functionality as the primary receiver unit 104. The receiver unit may be configured to be used in conjunction with a docking cradle unit, for example for one or more of the following or other functions: placement by bedside, for re-charging, for data management, for night time monitoring, and/or bi-directional communication device.

[0017] In one aspect sensor unit 101 may include two or more sensors, each configured to communicate with transmitter unit 102. Furthermore, while only one, transmitter unit 102, communication link 103, and data processing terminal 105 are shown in the embodiment of the analyte monitoring system 100 illustrated in FIG. 1. However, it will be appreciated by one of ordinary skill in the art that the analyte monitoring system 100 may include one or more sensors, multiple transmitter units 102, communication links 103, and data processing terminals 105. Moreover, within the scope of the

present disclosure, the analyte monitoring system 100 may be a continuous monitoring system, or semi-continuous, or a discrete monitoring system. In a multi-component environment, each device is configured to be uniquely identified by each of the other devices in the system so that communication conflict is readily resolved between the various components within the analyte monitoring system 100.

5 **[0018]** In one embodiment of the present disclosure, the sensor unit 101 is physically positioned in or on the body of a user whose analyte level is being monitored. The sensor unit 101 may be configured to continuously sample the analyte level of the user and convert the sampled analyte level into a corresponding data signal for transmission by the transmitter unit 102. In certain embodiments, the transmitter unit 102 may be physically coupled to the sensor unit 101 so that both devices are integrated in a single housing and positioned on the user's body. The transmitter unit 102 may perform data processing such as filtering and encoding on data signals and/or other functions, each of which corresponds to a sampled analyte level of the user, and in any event transmitter unit 102 transmits analyte information to the primary receiver unit 104 via the communication link 103.

10 **[0019]** In one embodiment, the analyte monitoring system 100 is configured as a one-way RF communication path from the transmitter unit 102 to the primary receiver unit 104. In such embodiment, the transmitter unit 102 transmits the sampled data signals received from the sensor unit 101 without acknowledgement from the primary receiver unit 104 that the transmitted sampled data signals have been received. For example, the transmitter unit 102 may be configured to transmit the encoded sampled data signals at a fixed rate (e.g., at one minute intervals) after the completion of the initial power on procedure. Likewise, the primary receiver unit 104 may be configured to detect such transmitted encoded sampled data signals at predetermined time intervals. Alternatively, the analyte monitoring system 100 may be configured with a bi-directional RF (or otherwise) communication between the transmitter unit 102 and the primary receiver unit 104.

15 **[0020]** Additionally, in one aspect, the primary receiver unit 104 may include two sections. The first section is an analog interface section that is configured to communicate with the transmitter unit 102 via the communication link 103. In one embodiment, the analog interface section may include an RF receiver and an antenna for receiving and amplifying the data signals from the transmitter unit 102, which are thereafter, demodulated with a local oscillator and filtered through a band-pass filter. The second section of the primary receiver unit 104 is a data processing section which is configured to process the data signals received from the transmitter unit 102 such as by performing data decoding, error detection and correction, data clock generation, and data bit recovery.

20 **[0021]** In operation, upon completing the power-on procedure, the primary receiver unit 104 is configured to detect the presence of the transmitter unit 102 within its range based on, for example, the strength of the detected data signals received from the transmitter unit 102 and/or a predetermined transmitter identification information. Upon successful synchronization with the corresponding transmitter unit 102, the primary receiver unit 104 is configured to begin receiving from the transmitter unit 102 data signals corresponding to the user's detected analyte level. More specifically, the primary receiver unit 104 in one embodiment is configured to perform synchronized time hopping with the corresponding synchronized transmitter unit 102 via the communication link 103 to obtain the user's detected analyte level.

25 **[0022]** Referring again to FIG. 1, the data processing terminal 105 may include a personal computer, a portable computer such as a laptop or a handheld device (e.g., personal digital assistants (PDAs)), and the like, each of which may be configured for data communication with the receiver via a wired or a wireless connection. Additionally, the data processing terminal 105 may further be connected to a data network (not shown) for storing, retrieving and updating data corresponding to the detected analyte level of the user.

30 **[0023]** Within the scope of the present disclosure, the data processing terminal 105 may include an infusion device such as an insulin infusion pump (external or implantable) or the like, which may be configured to administer insulin to patients, and which may be configured to communicate with the receiver unit 104 for receiving, among others, the measured analyte level. Alternatively, the receiver unit 104 may be configured to integrate or otherwise couple to an infusion device therein so that the receiver unit 104 is configured to administer insulin therapy to patients, for example, for administering and modifying basal profiles, as well as for determining appropriate boluses for administration based on, among others, the detected analyte levels received from the transmitter unit 102.

35 **[0024]** Additionally, the transmitter unit 102, the primary receiver unit 104 and the data processing terminal 105 may each be configured for bi-directional wireless communication such that each of the transmitter unit 102, the primary receiver unit 104 and the data processing terminal 105 may be configured to communicate (that is, transmit data to and receive data from) with each other via the wireless communication link 103. More specifically, the data processing terminal 105 may in one embodiment be configured to receive data directly from the transmitter unit 102 via the communication link 106, where the communication link 106, as described above, may be configured for bi-directional communication.

40 **[0025]** In this embodiment, the data processing terminal 105 which may include an insulin pump, may be configured to receive the analyte signals from the transmitter unit 102, and thus, incorporate the functions of the receiver 103 including data processing for managing the patient's insulin therapy and analyte monitoring. In one embodiment, the communication link 103 may include one or more of an RF communication protocol, an infrared communication protocol,

a Bluetooth enabled communication protocol, an 802.11x wireless communication protocol, or an equivalent wireless communication protocol which would allow secure, wireless communication of several units (for example, per HIPPA requirements) while avoiding potential data collision and interference.

5 [0026] FIG. 2 is a block diagram of the transmitter of the data monitoring and detection system shown in FIG. 1 in accordance with one embodiment of the present disclosure. Referring to the Figure, the transmitter unit 102 in one embodiment includes an analog interface 201 configured to communicate with the sensor unit 101 (FIG. 1), a user input 202, and a temperature detection section 203, each of which is operatively coupled to a transmitter processor 204 such as a central processing unit (CPU). As can be seen from FIG. 2, there are provided four contacts, three of which are electrodes - work electrode (W) 210, guard contact (G) 211, reference electrode (R) 212, and counter electrode (C) 213, each operatively coupled to the analog interface 201 of the transmitter unit 102 for connection to the sensor unit 101 (FIG. 1). In one embodiment, each of the work electrode (W) 210, guard contact (G) 211, reference electrode (R) 212, and counter electrode (C) 213 may be made using a conductive material that is either printed or etched or ablated, for example, such as carbon which may be printed, or a metal such as a metal foil (e.g., gold) or the like, which may be etched or ablated or otherwise processed to provide one or more electrodes. Fewer or greater electrodes and/or contact may be provided in certain embodiments.

10 [0027] Further shown in FIG. 2 are a transmitter serial communication section 205 and an RF transmitter 206, each of which is also operatively coupled to the transmitter processor 204. Moreover, a power supply 207 such as a battery is also provided in the transmitter unit 102 to provide the necessary power for the transmitter unit 102. Additionally, as can be seen from the Figure, clock 208 is provided to, among others, supply real time information to the transmitter processor 204.

15 [0028] In one embodiment, a unidirectional input path is established from the sensor unit 101 (FIG. 1) and/or manufacturing and testing equipment to the analog interface 201 of the transmitter unit 102, while a unidirectional output is established from the output of the RF transmitter 206 of the transmitter unit 102 for transmission to the primary receiver unit 104. In this manner, a data path is shown in FIG. 2 between the aforementioned unidirectional input and output via a dedicated link 209 from the analog interface 201 to serial communication section 205, thereafter to the processor 204, and then to the RF transmitter 206. As such, in one embodiment, via the data path described above, the transmitter unit 102 is configured to transmit to the primary receiver unit 104 (FIG. 1), via the communication link 103 (FIG. 1), processed and encoded data signals received from the sensor unit 101 (FIG. 1). Additionally, the unidirectional communication data path between the analog interface 201 and the RF transmitter 206 discussed above allows for the configuration of the transmitter unit 102 for operation upon completion of the manufacturing process as well as for direct communication for diagnostic and testing purposes.

20 [0029] As discussed above, the transmitter processor 204 is configured to transmit control signals to the various sections of the transmitter unit 102 during the operation of the transmitter unit 102. In one embodiment, the transmitter processor 204 also includes a memory (not shown) for storing data such as the identification information for the transmitter unit 102, as well as the data signals received from the sensor unit 101. The stored information may be retrieved and processed for transmission to the primary receiver unit 104 under the control of the transmitter processor 204. Furthermore, the power supply 207 may include a commercially available battery, which may be a rechargeable battery.

25 [0030] In certain embodiments, the transmitter unit 102 is also configured such that the power supply section 207 is capable of providing power to the transmitter for a minimum of about three months of continuous operation, e.g., after having been stored for about eighteen months such as stored in a low-power (non-operating) mode. In one embodiment, this may be achieved by the transmitter processor 204 operating in low power modes in the non-operating state, for example, drawing no more than approximately 1 μ A of current. Indeed, in one embodiment, a step during the manufacturing process of the transmitter unit 102 may place the transmitter unit 102 in the lower power, non-operating state (i.e., post-manufacture sleep mode). In this manner, the shelf life of the transmitter unit 102 may be significantly improved. Moreover, as shown in FIG. 2, while the power supply unit 207 is shown as coupled to the processor 204, and as such, the processor 204 is configured to provide control of the power supply unit 207, it should be noted that within the scope of the present disclosure, the power supply unit 207 is configured to provide the necessary power to each of the components of the transmitter unit 102 shown in FIG. 2.

30 [0031] Referring back to FIG. 2, the power supply section 207 of the transmitter unit 102 in one embodiment may include a rechargeable battery unit that may be recharged by a separate power supply recharging unit (for example, provided in the receiver unit 104) so that the transmitter unit 102 may be powered for a longer period of usage time. Moreover, in one embodiment, the transmitter unit 102 may be configured without a battery in the power supply section 207, in which case the transmitter unit 102 may be configured to receive power from an external power supply source (for example, a battery) as discussed in further detail below.

35 [0032] Referring yet again to FIG. 2, the temperature detection section 203 of the transmitter unit 102 is configured to monitor the temperature of the skin near the sensor insertion site. The temperature reading is used to adjust the analyte readings obtained from the analog interface 201. In certain embodiments, the RF transmitter 206 of the transmitter unit 102 may be configured for operation in the frequency band of approximately 315 MHz to approximately 322 MHz,

for example, in the United States. In certain embodiments, the RF transmitter 206 of the transmitter unit 102 may be configured for operation in the frequency band of approximately 400MHz to approximately 470MHz. Further, in one embodiment, the RF transmitter 206 is configured to modulate the carrier frequency by performing Frequency Shift Keying and Manchester encoding. In one embodiment, the data transmission rate is about 19,200 symbols per second, with a minimum transmission range for communication with the primary receiver unit 104.

[0033] Referring yet again to FIG. 2, also shown is a leak detection circuit 214 coupled to the guard electrode (G) 211 and the processor 204 in the transmitter unit 102 of the data monitoring and management system 100. The leak detection circuit 214 in accordance with one embodiment of the present disclosure may be configured to detect leakage current in the sensor unit 101 to determine whether the measured sensor data are corrupt or whether the measured data from the sensor 101 is accurate. Exemplary analyte systems that may be employed are described in, for example, U.S. Patent Nos. 6,134,461, 6,175,752, 6,121,611, 6,560,471, 6,746,582, and elsewhere, the disclosure of each of which are incorporated by reference for all purposes.

[0034] FIG. 3 is a block diagram of the receiver/monitor unit of the data monitoring and management system shown in FIG. 1 in accordance with one embodiment of the present disclosure. Referring to FIG. 3, the primary receiver unit 104 includes an analyte test strip, e.g., blood glucose test strip, interface 301, an RF receiver 302, an input 303, a temperature detection section 304, and a clock 305, each of which is operatively coupled to a receiver processor 307. As can be further seen from the Figure, the primary receiver unit 104 also includes a power supply 306 operatively coupled to a power conversion and monitoring section 308. Further, the power conversion and monitoring section 308 is also coupled to the receiver processor 307. Moreover, also shown are a receiver serial communication section 309, and an output 310, each operatively coupled to the receiver processor 307.

[0035] In one embodiment, the test strip interface 301 includes a glucose level testing portion to receive a manual insertion of a glucose test strip, and thereby determine and display the glucose level of the test strip on the output 310 of the primary receiver unit 104. This manual testing of glucose may be used to calibrate the sensor unit 101 or otherwise. The RF receiver 302 is configured to communicate, via the communication link 103 (FIG. 1) with the RF transmitter 206 of the transmitter unit 102, to receive encoded data signals from the transmitter unit 102 for, among others, signal mixing, demodulation, and other data processing. The input 303 of the primary receiver unit 104 is configured to allow the user to enter information into the primary receiver unit 104 as needed. In one aspect, the input 303 may include one or more keys of a keypad, a touch-sensitive screen, or a voice-activated input command unit. The temperature detection section 304 is configured to provide temperature information of the primary receiver unit 104 to the receiver processor 307, while the clock 305 provides, among others, real time information to the receiver processor 307.

[0036] Each of the various components of the primary receiver unit 104 shown in FIG. 3 is powered by the power supply 306 which, in one embodiment, includes a battery. Furthermore, the power conversion and monitoring section 308 is configured to monitor the power usage by the various components in the primary receiver unit 104 for effective power management and to alert the user, for example, in the event of power usage which renders the primary receiver unit 104 in sub-optimal operating conditions. An example of such sub-optimal operating condition may include, for example, operating the vibration output mode (as discussed below) for a period of time thus substantially draining the power supply 306 while the processor 307 (thus, the primary receiver unit 104) is turned on. Moreover, the power conversion and monitoring section 308 may additionally be configured to include a reverse polarity protection circuit such as a field effect transistor (FET) configured as a battery activated switch.

[0037] The serial communication section 309 in the primary receiver unit 104 is configured to provide a bi-directional communication path from the testing and/or manufacturing equipment for, among others, initialization, testing, and configuration of the primary receiver unit 104. Serial communication section 104 can also be used to upload data to a computer, such as time-stamped blood glucose data. The communication link with an external device (not shown) can be made, for example, by cable, infrared (IR) or RF link. The output 310 of the primary receiver unit 104 is configured to provide, among others, a graphical user interface (GUI) such as a liquid crystal display (LCD) for displaying information. Additionally, the output 310 may also include an integrated speaker for outputting audible signals as well as to provide vibration output as commonly found in handheld electronic devices, such as mobile telephones presently available. In a further embodiment, the primary receiver unit 104 also includes an electro-luminescent lamp configured to provide backlighting to the output 310 for output visual display in dark ambient surroundings.

[0038] Referring back to FIG. 3, the primary receiver unit 104 in one embodiment may also include a storage section such as a programmable, non-volatile memory device as part of the processor 307, or provided separately in the primary receiver unit 104, operatively coupled to the processor 307. The processor 307 may be configured to synchronize with a transmitter, e.g., using Manchester decoding or the like, as well as error detection and correction upon the encoded data signals received from the transmitter unit 102 via the communication link 103.

[0039] Additional description of the RF communication between the transmitter 102 and the primary receiver 104 (or with the secondary receiver 106) that may be employed in embodiments of the subject invention is disclosed in pending application no. 11/060,365 filed February 16, 2005 entitled "Method and System for Providing Data Communication in Continuous Glucose Monitoring and Management System" the disclosure of which is incorporated herein by reference

for all purposes.

[0040] Referring to the Figures, in one embodiment, the transmitter 102 (FIG. 1) may be configured to generate data packets for periodic transmission to one or more of the receiver units 104, 106, where each data packet includes in one embodiment two categories of data - urgent data and non-urgent data. For example, urgent data such as for example glucose data from the sensor and/or temperature data associated with the sensor may be packed in each data packet in addition to non-urgent data, where the non-urgent data is rolled or varied with each data packet transmission.

[0041] That is, the non-urgent data is transmitted at a timed interval so as to maintain the integrity of the analyte monitoring system without being transmitted over the RF communication link with each data transmission packet from the transmitter 102. In this manner, the non-urgent data, for example that are not time sensitive, may be periodically transmitted (and not with each data packet transmission) or broken up into predetermined number of segments and sent or transmitted over multiple packets, while the urgent data is transmitted substantially in its entirety with each data transmission.

[0042] Referring again to the Figures, upon receiving the data packets from the transmitter 102, the one or more receiver units 104, 106 may be configured to parse the received data packet to separate the urgent data from the non-urgent data, and also, may be configured to store the urgent data and the non-urgent data, e.g., in a hierarchical manner. In accordance with the particular configuration of the data packet or the data transmission protocol, more or less data may be transmitted as part of the urgent data, or the non-urgent rolling data. That is, within the scope of the present disclosure, the specific data packet implementation such as the number of bits per packet, and the like, may vary based on, among others, the communication protocol, data transmission time window, and so on.

[0043] In an exemplary embodiment, different types of data packets may be identified accordingly. For example, identification in certain exemplary embodiments may include - (1) single sensor, one minute of data, (2) two or multiple sensors, (3) dual sensor, alternate one minute data, and (4) response packet. For single sensor one minute data packet, in one embodiment, the transmitter 102 may be configured to generate the data packet in the manner, or similar to the manner, shown in Table 1 below.

Table 1. Single sensor, one minute of data

Number of Bits	Data Field
8	Transmit Time
14	Sensor1 Current Data
14	Sensor1 Historic Data
8	Transmit Status
12	AUX Counter
12	AUX Thermistor 1
12	AUX Thermistor 2
8	Rolling-Data-1

[0044] As shown in Table 1 above, the transmitter data packet in one embodiment may include 8 bits of transmit time data, 14 bits of current sensor data, 14 bits of preceding sensor data, 8 bits of transmitter status data, 12 bits of auxiliary counter data, 12 bits of auxiliary thermistor 1 data, 12 bits of auxiliary thermistor 1 data and 8 bits of rolling data. In one embodiment of the present disclosure, the data packet generated by the transmitter for transmission over the RF communication link may include all or some of the data shown above in Table 1.

[0045] Referring back, the 14 bits of the current sensor data provides the real time or current sensor data associated with the detected analyte level, while the 14 bits of the sensor historic or preceding sensor data includes the sensor data associated with the detected analyte level one minute ago. In this manner, in the case where the receiver unit 104, 106 drops or fails to successfully receive the data packet from the transmitter 102 in the minute by minute transmission, the receiver unit 104, 106 may be able to capture the sensor data of a prior minute transmission from a subsequent minute transmission.

[0046] Referring again to Table 1, the Auxiliary data in one embodiment may include one or more of the patient's skin temperature data, a temperature gradient data, reference data, and counter electrode voltage. The transmitter status field may include status data that is configured to indicate corrupt data for the current transmission (for example, if shown as BAD status (as opposed to GOOD status which indicates that the data in the current transmission is not corrupt)). Furthermore, the rolling data field is configured to include the non-urgent data, and in one embodiment, may be associated with the time-hop sequence number. In addition, the Transmitter Time field in one embodiment includes a protocol value

EP 2 280 636 B1

that is configured to start at zero and is incremented by one with each data packet. In one aspect, the transmitter time data may be used to synchronize the data transmission window with the receiver unit 104, 106, and also, provide an index for the Rolling data field.

[0047] In a further embodiment, the transmitter data packet may be configured to provide or transmit analyte sensor data from two or more independent analyte sensors. The sensors may relate to the same or different analyte or property. In such a case, the data packet from the transmitter 102 may be configured to include 14 bits of the current sensor data from both sensors in the embodiment in which 2 sensors are employed. In this case, the data packet does not include the immediately preceding sensor data in the current data packet transmission. Instead, a second analyte sensor data is transmitted with a first analyte sensor data.

Table 2. Dual sensor data

Number of Bits	Data Field
8	Transmit Time
14	Sensor1 Current Data
14	Sensor2 Current Data
8	Transmit Status
12	AUX Counter
12	AUX Thermistor 1
12	AUX Thermistor 2
8	Rolling-Data-1

[0048] In a further embodiment, the transmitter data packet may be alternated with each transmission between two analyte sensors, for example, alternating between the data packet shown in Table 3 and Table 4 below.

Table 3. Sensor Data Packet Alternate 1

Number of Bits	Data Field
8	Transmitter Time
14	Sensor1 Current Data
14	Sensor1 Historic Data
8	Transmit Status
12	AUX Counter
12	AUX Thermistor 1
12	AUX Thermistor 2
8	Rolling-Data-1

Table 4. Sensor Data Packet Alternate 2

Number of Bits	Data Field
8	Transmitter Time
14	Sensor1 Current Data
14	Sensor2 Current Data
8	Transmit Status
12	AUX Counter
12	AUX Thermistor 1
12	AUX Thermistor 2

(continued)

Number of Bits	Data Field
8	Rolling-Data-1

5
10
[0049] As shown above in reference to Tables 3 and 4, the minute by minute data packet transmission from the transmitter 102 (FIG. 1) in one embodiment may alternate between the data packet shown in Table 3 and the data packet shown in Table 4. More specifically, the transmitter 102 may be configured in one embodiment to transmit the current sensor data of the first sensor and the preceding sensor data of the first sensor (Table 3), as well as the rolling data, and further, at the subsequent transmission, the transmitter 102 may be configured to transmit the current sensor data of the first and the second sensor in addition to the rolling data.

15
[0050] In one embodiment, the rolling data transmitted with each data packet may include a sequence of various predetermined types of data that are considered not-urgent or not time sensitive. That is, in one embodiment, the following list of data shown in Table 5 may be sequentially included in the 8 bits of transmitter data packet, and not transmitted with each data packet transmission of the transmitter (for example, with each 60 second data transmission from the transmitter 102).

Table 5. Rolling Data

Time Slot	Bits	Rolling-Data
0	8	Mode
1	8	Glucose1 Slope
2	8	Glucose2 Slope
3	8	Ref-R
4	8	Hobbs Counter, Ref-R
5	8	Hobbs Counter
6	8	Hobbs Counter
7	8	Sensor Count

20
25
30
35
[0051] As can be seen from Table 5 above, in one embodiment, a sequence of rolling data are appended or added to the transmitter data packet with each data transmission time slot. In one embodiment, there may be 256 time slots for data transmission by the transmitter 102 (FIG. 1), and where, each time slot is separately by approximately 60 second interval. For example, referring to the Table 5 above, the data packet in transmission time slot 0 (zero) may include operational mode data (Mode) as the rolling data that is appended to the transmitted data packet. At the subsequent data transmission time slot (for example, approximately 60 seconds after the initial time slot (0), the transmitted data packet may include the analyte sensor 1 calibration factor information (Glucose1 slope) as the rolling data. In this manner, with each data transmission, the rolling data may be updated over the 256 time slot cycle.

40
45
[0052] Referring again to Table 5, each rolling data field is described in further detail for various embodiments. For example, the Mode data may include information related to the different operating modes such as, but not limited to, the data packet type, the type of battery used, diagnostic routines, single sensor or multiple sensor input, or type of data transmission (RF communication link or other data link such as serial connection). Further, the Glucose1-slope data may include an 8-bit scaling factor or calibration data for first sensor (scaling factor for sensor 1 data), while Glucose2-slope data may include an 8-bit scaling factor or calibration data for the second analyte sensor (in the embodiment including more than one analyte sensors).

50
[0053] In addition, the Ref-R data may include 12 bits of on-board reference resistor used to calibrate our temperature measurement in the thermister circuit (where 8 bits are transmitted in time slot 3, and the remaining 4 bits are transmitted in time slot 4), and the 20-bit Hobbs counter data may be separately transmitted in three time slots (for example, in time slot 4, time slot 5 and time slot 6) to add up to 20 bits. In one embodiment, the Hobbs counter may be configured to count each occurrence of the data transmission (for example, a packet transmission at approximately 60 second intervals) and may be incremented by a count of one (1).

55
[0054] In one aspect, the Hobbs counter is stored in a nonvolatile memory of the transmitter unit 102 (FIG. 1) and may be used to ascertain the power supply status information such as, for example, the estimated battery life remaining in the transmitter unit 102. That is, with each sensor replacement, the Hobbs counter is not reset, but rather, continues the

count with each replacement of the sensor unit 101 to establish contact with the transmitter unit 102 such that, over an extended usage time period of the transmitter unit 102, it may be possible to determine, based on the Hobbs count information, the amount of consumed battery life in the transmitter unit 102, and also, an estimated remaining life of the battery in the transmitter unit 102.

5 **[0055]** That is, in one embodiment, the 20 bit Hobbs counter is incremented by one each time the transmitter unit 102 transmits a data packet (for example, approximately each 60 seconds), and based on the count information in the Hobbs counter, in one aspect, the battery life of the transmitter unit 102 may be estimated. In this manner, in configurations of the transmitter unit 620 (see FIG. 6) where the power supply is not a replaceable component but rather, embedded within the housing the transmitter unit 620, it is possible to estimate the remaining life of the embedded battery within 10 the transmitter unit 620. Moreover, the Hobbs counter is configured to remain persistent in the memory device of the transmitter unit 620 such that, even when the transmitter unit power is turned off or powered down (for example, during the periodic sensor unit replacement, RF transmission turned off period and the like), the Hobbs counter information is retained.

15 **[0056]** Referring to Table 5 above, the transmitted rolling data may also include 8 bits of sensor count information (for example, transmitted in time slot 7). The 8 bit sensor counter is incremented by one each time a new sensor unit is connected to the transmitter unit. The application specific integrated circuit (ASIC) configuration of the transmitter unit (or a microprocessor based transmitter configuration or with discrete components) may be configured to store in a nonvolatile memory unit the sensor count information and transmit it to the primary receiver unit 104 (for example). In turn, the primary receiver unit 104 (and/or the secondary receiver unit 106) may be configured to determine whether it 20 is receiving data from the transmitter unit that is associated with the same sensor unit (based on the sensor count information), or from a new or replaced sensor unit (which will have a sensor count incremented by one from the prior sensor count). In this manner, in one aspect, the receiver unit (primary or secondary) may be configured to prevent reuse of the same sensor unit by the user based on verifying the sensor count information associated with the data transmission received from the transmitter unit 102. In addition, in a further aspect, user notification may be associated 25 with one or more of these parameters. Further, the receiver unit (primary or secondary) may be configured to detect when a new sensor has been inserted, and thus prevent erroneous application of one or more calibration parameters determined in conjunction with a prior sensor, that may potentially result in false or inaccurate analyte level determination based on the sensor data.

30 **[0057]** FIG. 4 is a flowchart illustrating a data packet procedure including rolling data for transmission in accordance with one embodiment of the present disclosure. Referring to FIG. 4, in one embodiment, a counter is initialized (for example, to $T = 0$) (410). Thereafter the associated rolling data is retrieved from memory device, for example (420), and also, the time sensitive or urgent data is retrieved (430). In one embodiment, the retrieval of the rolling data (420) and the retrieval of the time sensitive data (430) may be retrieved at substantially the same time.

35 **[0058]** Referring back to FIG. 4, with the rolling data and the time sensitive data, for example, the data packet for transmission is generated (440), and upon transmission, the counter is incremented by one (450) and the routine returns to retrieval of the rolling data (420). In this manner, in one embodiment, the urgent time sensitive data as well as the non-urgent data may be incorporated in the same data packet and transmitted by the transmitter 102 (FIG. 1) to a remote device such as one or more of the receivers 104, 106. Furthermore, as discussed above, the rolling data may be updated at a predetermined time interval which is longer than the time interval for each data packet transmission from the 40 transmitter 102 (FIG. 1).

45 **[0059]** FIG. 5 is a flowchart illustrating data processing of the received data packet including the rolling data in accordance with one embodiment of the present disclosure. Referring to FIG. 5, when the data packet is received (510) (for example, by one or more of the receivers 104, 106, in one embodiment) the received data packet is parsed so that the urgent data may be separated from the not-urgent data (stored in, for example, the rolling data field in the data packet) (520). Thereafter the parsed data is suitably stored in an appropriate memory or storage device (530).

50 **[0060]** In the manner described above, in accordance with one embodiment of the present disclosure, there is provided method and apparatus for separating non-urgent type data (for example, data associated with calibration) from urgent type data (for example, monitored analyte related data) to be transmitted over the communication link to minimize the potential burden or constraint on the available transmission time. More specifically, in one embodiment, non-urgent data may be separated from data that is required by the communication system to be transmitted immediately, and transmitted over the communication link together while maintaining a minimum transmission time window. In one embodiment, the non-urgent data may be parsed or broken up in to a number of data segments, and transmitted over multiple data packets. The time sensitive immediate data (for example, the analyte sensor data, temperature data, etc.), may be transmitted over the communication link substantially in its entirety with each data packet or transmission.

55 **[0061]** FIG. 6 is a block diagram illustrating the sensor unit and the transmitter unit of the data monitoring and management system of FIG. 1 in accordance with one embodiment of the present disclosure. Referring to FIG. 6, in one aspect, a transmitter unit 620 is provided in a substantially water tight and sealed housing. The transmitter unit 620 includes respective contacts (wrk, ref, cntr, and grd) for respectively establishing electrical contact with one or more of

the working electrode, the reference electrode, the counter electrode and the ground terminal (or guard trace) of the sensor unit 610. Also shown in FIG. 6 is a conductivity bar/trace 611 provided on the sensor unit 610. For example, in one embodiment, the conductivity bar/trace 611 may comprise a carbon trace on a substrate layer of the sensor unit 610. In this manner, in one embodiment, when the sensor unit 610 is coupled to the transmitter unit 620, electrical contact is established, for example, via the conductivity bar/trace 611 between the contact pads or points of the transmitter unit 620 (for example, at the counter electrode contact (cntr) and the ground terminal contact (grd) such that the transmitter unit 620 may be powered for data communication.

[0062] That is, during manufacturing of the transmitter unit 620, in one aspect, the transmitter unit 620 is configured to include a power supply such as battery 621. Further, during the initial non-use period (e.g., post manufacturing sleep mode), the transmitter unit 620 is configured such that it is not used and thus drained by the components of the transmitter unit 620. During the sleep mode, and prior to establishing electrical contact with the sensor unit 610 via the conductivity bar/trace 611, the transmitter unit 620 is provided with a low power signal from, for example, a low power voltage comparator 622, via an electronic switch 623 to maintain the low power state of, for example, the transmitter unit 620 components. Thereafter, upon connection with the sensor unit 610, and establishing electrical contact via the conductivity bar/trace 611, the embedded power supply 621 of the transmitter unit 620 is activated or powered up so that some of all of the components of the transmitter unit 620 are configured to receive the necessary power signals for operations related to, for example, data communication, processing and/or storage.

[0063] In one aspect, since the transmitter unit 620 is configured to a sealed housing without a separate replaceable battery compartment, in this manner, the power supply of the battery 621 is preserved during the post manufacturing sleep mode prior to use.

[0064] In a further aspect, the transmitter unit 620 may be disposed or positioned on a separate on-body mounting unit that may include, for example, an adhesive layer (on its bottom surface) to firmly retain the mounting unit on the skin of the user, and which is configured to receive or firmly position the transmitter unit 620 on the mounting unit during use. In one aspect, the mounting unit may be configured to at least partially retain the position of the sensor unit 610 in a transcutaneous manner so that at least a portion of the sensor unit is in fluid contact with the analyte of the user. Example embodiments of the mounting or base unit and its cooperation or coupling with the transmitter unit are provided, for example, in US Patent No. 6,175,752, incorporated herein by reference for all purposes.

[0065] In such a configuration, the power supply for the transmitter unit 620 may be provided within the housing of the mounting unit such that, the transmitter unit 620 may be configured to be powered on or activated upon placement of the transmitter unit 620 on the mounting unit and in electrical contact with the sensor unit 610. For example, the sensor unit 610 may be provided pre-configured or integrated with the mounting unit and the insertion device such that, the user may position the sensor unit 610 on the skin layer of the user using the insertion device coupled to the mounting unit. Thereafter, upon transcutaneous positioning of the sensor unit 610, the insertion device may be discarded or removed from the mounting unit, leaving behind the transcutaneously positioned sensor unit 610 and the mounting unit on the skin surface of the user.

[0066] Thereafter, when the transmitter unit 620 is positioned on, over or within the mounting unit, the battery or power supply provided within the mounting unit is configured to electrically couple to the transmitter unit 620 and/or the sensor unit 610. Given that the sensor unit 610 and the mounting unit are provided as replaceable components for replacement every 3, 5, 7 days or other predetermined time periods, the user is conveniently not burdened with verifying the status of the power supply providing power to the transmitter unit 620 during use. That is, with the power supply or battery replaced with each replacement of the sensor unit 610, a new power supply or battery will be provided with the new mounting unit for use with the transmitter unit 620.

[0067] Referring to FIG. 6 again, in one aspect, when the sensor unit 610 is removed from the transmitter unit 620 (or vice versa), the electrical contact is broken and the conductivity bar/trace 611 returns to an open circuit. In this case, the transmitter unit 620 may be configured, to detect such condition and generate a last gasp transmission sent to the primary receiver unit 104 (and/or the secondary receiver unit 106) indicating that the sensor unit 610 is disconnected from the transmitter unit 620, and that the transmitter unit 620 is entering a powered down (or low power off) state. And the transmitter unit 620 is powered down into the sleep mode since the connection to the power supply (that is embedded within the transmitter unit 620 housing) is broken.

[0068] In this manner, in one aspect, the processor 624 of the transmitter unit 620 may be configured to generate the appropriate one or more data or signals associated with the detection of sensor unit 610 disconnection for transmission to the receiver unit 104 (FIG. 1), and also, to initiate the power down procedure of the transmitter unit 620. In one aspect, the components of the transmitter unit 620 may be configured to include application specific integrated circuit (ASIC) design with one or more state machines and one or more nonvolatile and/or volatile memory units such as, for example, EEPROMs and the like.

[0069] Referring again to FIGS. 1 and 6, in one embodiment, the communication between the transmitter unit 620 (or 102 of FIG. 1) and the primary receiver unit 104 (and/or the secondary receiver unit 106) may be based on close proximity communication where bi-directional (or uni-directional) wireless communication is established when the devices are

physically located in close proximity to each other. That is, in one embodiment, the transmitter unit 620 may be configured to receive very short range commands from the primary receiver unit 104 (FIG. 1) and perform one or more specific operations based on the received commands from the receiver unit 104).

5 [0070] In one embodiment, to maintain secure communication between the transmitter unit and the data receiver unit, the transmitter unit ASIC may be configured to generate a unique close proximity key at power on or initialization. In one aspect, the 4 or 8 bit key may be generated based on, for example, the transmitter unit identification information, and which may be used to prevent undesirable or unintended communication. In a further aspect, the close proximity key may be generated by the receiver unit based on, for example, the transmitter identification information received by the transmitter unit during the initial synchronization or pairing procedure of the transmitter and the receiver units.

10 [0071] Referring again to FIGS. 1 and 6, in one embodiment, the transmitter unit ASIC configuration may include a 32KHz oscillator and a counter which may be configured to drive the state machine in the transmitter unit ASIC. The transmitter ASIC configuration may include a plurality of close proximity communication commands including, for example, new sensor initiation, pairing with the receiver unit, and RF communication control, among others. For example, when a new sensor unit is positioned and coupled to the transmitter unit so that the transmitter unit is powered on, the transmitter unit is configured to detect or receive a command from the receiver unit positioned in close proximity to the transmitter unit. For example, the receiver unit may be positioned within a couple of inches from the on-body position of the transmitter unit, and when the user activates or initiates a command associated with the new sensor initiation from the receiver unit, the transmitter unit is configured to receive the command from the receiver and, in its response data packet, transmit, among others, its identification information back to the receiver unit.

20 [0072] In one embodiment, the initial sensor unit initiation command does not require the use of the close proximity key. However, other predefined or preconfigured close-proximity commands may be configured to require the use of the 8 bit key (or a key of a different number of bits). For example, in one embodiment, the receiver unit may be configured to transmit a RF on/off command to turn on/off the RF communication module or unit in the transmitter unit 102. Such RF on/off command in one embodiment includes the close proximity key as part of the transmitted command for reception by the transmitter unit.

25 [0073] During the period that the RF communication module or unit is turned off based on the received close proximity command, the transmitter unit does not transmit any data, including any glucose related data. In one embodiment, the glucose related data from the sensor unit which are not transmitted by the transmitter unit during the time period when the RF communication module or unit of the transmitter unit is turned off may be stored in a memory or storage unit of the transmitter unit for subsequent transmission to the receiver unit when the transmitter unit RF communication module or unit is turned back on based on the RF-on command from the receiver unit. In this manner, in one embodiment, the transmitter unit may be powered down (temporarily, for example, during air travel) without removing the transmitter unit from the on-body position.

30 [0074] FIG. 7 is a flowchart illustrating data communication using close proximity commands in the data monitoring and management system of FIG. 1 in accordance with one embodiment of the present disclosure. Referring to FIG. 7, the primary receiver unit 104 (FIG. 1) in one aspect may be configured to retrieve or generate a close proximity command (710) for transmission to the transmitter unit 102. To establish the transmission range (720), the primary receiver unit 104 may be positioned physically close to (that is, within a predetermined distance from) the transmitter unit 102. For example, the transmission range for the close proximity communication may be established at approximately one foot distance or less between the transmitter unit 102 and the primary receiver unit 104. When the transmitter unit 102 and the primary receiver unit 104 are within the transmission range, the close proximity command, upon initiation from the receiver unit 104 may be transmitted to the transmitter unit 102 (730).

35 [0075] Referring back to FIG. 7, in response to the transmitted close proximity command, a response data packet or other responsive communication may be received (740). In one aspect, the response data packet or other responsive communication may include identification information of the transmitter unit 102 transmitting the response data packer or other response communication to the receiver unit 104. In one aspect, the receiver unit 104 may be configured to generate a key (for example, an 8 bit key or a key of a predetermined length) based on the transmitter identification information (750), and which may be used in subsequent close proximity communication between the transmitter unit 102 and the receiver unit 104.

40 [0076] In one aspect, the data communication including the generated key may allow the recipient of the data communication to recognize the sender of the data communication and confirm that the sender of the data communication is the intended data sending device, and thus, including data which is desired or anticipated by the recipient of the data communication. In this manner, in one embodiment, one or more close proximity commands may be configured to include the generated key as part of the transmitted data packet. Moreover, the generated key may be based on the transmitter ID or other suitable unique information so that the receiver unit 104 may use such information for purposes of generating the unique key for the bi-directional communication between the devices.

45 [0077] While the description above includes generating the key based on the transmitter unit 102 identification information, within the scope of the present disclosure, the key may be generated based on one or more other information

associated with the transmitter unit 102, and/or the receiver unit combination. In a further embodiment, the key may be encrypted and stored in a memory unit or storage device in the transmitter unit 102 for transmission to the receiver unit 104.

5 [0078] FIG. 8 is a flowchart illustrating the pairing or synchronization routine in the data monitoring and management system of FIG. 1 in accordance with one embodiment of the present disclosure. Referring to FIG. 8, in one embodiment, the transmitter unit 102 may be configured to receive a sensor initiate close proximity command (810) from the receiver unit 104 positioned within the close transmission range. Based on the received sensor initiate command, the transmitter unit identification information may be retrieved (for example, from a nonvolatile memory) and transmitted (820) to the receiver unit 104 or the sender of the sensor initiate command.

10 [0079] Referring back to FIG. 8, a communication key (830) optionally encrypted is received in one embodiment, and thereafter, sensor related data is transmitted with the communication key on a periodic basis such as, every 60 seconds, five minutes, or any suitable predetermined time intervals (840).

15 [0080] Referring now to FIG. 9, a flowchart illustrating the pairing or synchronization routine in the data monitoring and management system of FIG. 1 in accordance with another embodiment of the present disclosure is shown. That is, in one aspect, FIG. 9 illustrates the pairing or synchronization routine from the receiver unit 104. Referring back to FIG. 9, the sensor initiate command is transmitted to the transmitter unit 102 (910) when the receiver unit 104 is positioned within a close transmission range. Thereafter, in one aspect, the transmitter identification information is received (920) for example, from the transmitter unit that received the sensor initiate command. Thereafter, a communication key (optionally encrypted) may be generated and transmitted (930) to the transmitter unit.

20 [0081] In the manner described above, in one embodiment, a simplified pairing or synchronization between the transmitter unit 102 and the receiver unit 104 may be established using, for example, close proximity commands between the devices. As described above, in one aspect, upon pairing or synchronization, the transmitter unit 102 may be configured to periodically transmit analyte level information to the receiver unit for further processing.

25 [0082] FIG. 10 is a flowchart illustrating the power supply determination in the data monitoring and management system of FIG. 1 in accordance with one embodiment of the present disclosure. That is, in one embodiment, using a counter, the receiver unit 104 may be configured to determine the power supply level of the transmitter unit 102 battery so as to determine a suitable time for replacement of the power supply or the transmitter unit 102 itself. Referring to FIG. 10, periodic data transmission is detected (1010), and a corresponding count in the counter is incremented for example, by one with each detected data transmission (1020). In particular, a Hobbs counter may be used in the rolling data configuration described above to provide a count that is associated with the transmitter unit data transmission occurrence.

30 [0083] Referring to FIG. 10, the updated or incremented count stored in the Hobbs counter is periodically transmitted in the data packet from the transmitter unit 102 to the receiver unit 104 (1030). Moreover, the incremented or updated count may be stored (1040) in a persistent nonvolatile memory unit of the transmitter unit 102. Accordingly, based on the number of data transmission occurrences, the battery power supply level may be estimated, and in turn, which may provide an indication as to when the battery (and thus the transmitter unit in the embodiment where the power supply is manufactured to be embedded within the transmitter unit housing) needs to be replaced.

35 [0084] Moreover, in one aspect, the incremented count in the Hobbs counter is stored in a persistent nonvolatile memory such that, the counter is not reset or otherwise restarted with each sensor unit replacement.

40 [0085] FIG. 11 is a flowchart illustrating close proximity command for RF communication control in the data monitoring and management system of FIG. 1 in accordance with one embodiment of the present disclosure. Referring to FIG. 11, a close proximity command associated with communication status, for example is received (1110). In one aspect, the command associated with the communication status may include, for example, a communication module turn on or turn off command for, for example, turning on or turning off the associated RF communication device of the transmitter unit 102. Referring to FIG. 11, the communication status is determined (1120), and thereafter, modified based on the received command (1130).

45 [0086] That is, in one aspect, using one or more close proximity commands, the receiver unit 104 may be configured to control the RF communication of the transmitter unit 102 to, for example, disable or turn off the RF communication functionality for a predetermined time period. This may be particularly useful when used in air travel or other locations such as hospital settings, where RF communication devices need to be disabled. In one aspect, the close proximity command may be used to either turn on or turn off the RF communication module of the transmitter unit 102, such that, when the receiver unit 104 is positioned in close proximity to the transmitter unit 102, and the RF command is transmitted, the transmitter unit 102 is configured, in one embodiment, to either turn off or turn on the RF communication capability of the transmitter unit 102.

50 [0087] FIG. 12 illustrates a data format of a close proximity data packet sent by a controller such as the receiver unit 104/106 to the transmitter unit 620 (FIG. 6) in the analyte monitoring system 100 (FIG. 1). Referring to FIG. 12, in one embodiment, a close proximity data packet sent by the controller may include 24 bits of data. In one aspect, the 24 bit data packet may include a dotting pattern 1210, a data frame 1220, one or more close proximity commands 1230, and a close proximity key 1240. As discussed in further detail below, in one embodiment, a sequence detector 1330 (FIG. 13) in the transmitter unit 620 ASIC logic uses the dotting pattern 1210 and the data frame 1220 to determine whether

the incoming data is a proper close proximity data packet. In one aspect, the close proximity data packet as shown in FIG. 12 may include dotting pattern 1210 which may be used by the close proximity detector logic to detect and synchronize the received data, the data frame 1220 that includes bit pattern prior to the actual received data, the close proximity commands 1230, and close proximity key 1240 to validate the close proximity communication.

5 [0088] In one aspect, there may be five valid close proximity commands 1230 and the close proximity key 1240 may be used as a validation for the communication received from the controller (receiver unit 104/106) for example. While a 24 bit data packet for the close proximity command and five valid close proximity commands 1230 are described above, within the scope of the present disclosure, the data packet for the close proximity commands may include greater or less number of bits within the data packet, and further, the number of valid close proximity commands may be greater or fewer than five valid close proximity commands as described above.

10 [0089] FIG. 13 is a block diagram representation of a close proximity detection logic of the transmitter unit 620 in one or more embodiments of the present disclosure. Referring to FIG. 13, in one embodiment, incoming Manchester encoded data packet, for example, from the controller (receiver unit 104/106) is received at a rate of approximately 4.8 Kbits/second by the close proximity detector logic and decoded by a Manchester bit decoder logic 1310. The Manchester bit decoder logic 1310 detects the two data symbols and may be configured to convert the detected data to one data bit at 2.4 Kbits/sec.

15 [0090] In one aspect, the decoded data bit is sent to a bit timing counter logic 1320, a sequence detector logic 1330, and the shift register logic 1340. In one embodiment, the sequence detector logic 1330 looks for a predetermined data pattern showing the authenticity of the received data packet. In one aspect, the predetermined data pattern, for example '0100', includes an occurrence of a dotting pattern '01' and a data frame '00'. If only a partial sequence is detected followed by an incorrect data bit, the sequence detector logic 1330 may be configured to reset and wait for the next data packet. On the other hand, if the correct data packet is received with the expected or anticipated predetermined data pattern, for example, a '0100', then the sequence detector logic 1330 deems the data packet to be valid.

20 [0091] When the data packet is determined to have the correct dotting pattern and data frame, and is deemed to be valid, a reset signal is disabled and a shift register signal is enabled. With a shift register signal enabled, each incoming bit of validated data is latched into an 11 bit envelope detector shift register logic 1340. Once the 11th bit is latched into the register 1340, an on/off keying (OOK) signal indicates that close proximity communication has been completed. Once a close proximity command is sent and decoded, an envelope detect finite state machine (FSM) logic 1360 is configured to process the command. During the processing period, no further commands are accepted, and the close proximity state machine logic 1360 is locked in a final state. Once the command has been processed, the close proximity logic is reset by a logic reset signal. The close proximity logic then returns to its initial state and awaits further instructions.

25 [0092] Referring again to FIG. 13, a close proximity key 1350 may be used in conjunction with the close proximity command data packet to determine or confirm the identity of the close proximity command issuing device, such as, for example, the controller (receiver unit 104/106). For example, in one aspect, each transmitter unit 102, 620 (FIGS. 1, 6) may have a unique key based on, for example, the device serial or identification number. This value may be latched or stored, and provided to the close proximity logic, and when a close proximity communication is completed, the received key value as part of the close proximity command data packet is compared to the latched unique key. If the two values match, a signal corresponding to a key match is set high, indicating that the close proximity command received is intended for the transmitter unit that received the command.

30 [0093] Referring again to FIG. 13, a time out signal in conjunction with a bit timing counter 1320 may be used to determine whether transmission errors may have occurred. For example, each time a valid data bit is received by the close proximity logic of the transmitter unit 104/620, a time out signal is generated by the bit timing counter logic 1320. In one aspect, the time period between each time out signal is compared by the bit timing counter logic 1320, and if it is determined that the time period is greater than a predetermined time period based on the data bit time (for example, approximately 1.75 times the data bit time), then it is determined that the data transmission is in error. If it is determined that the transmission is in error, the state machine logic 1360 may be configured to reset the shift register logic 1340, sequence detector logic 1330, and the bit timer logic 1320. On the other hand, when it is determined that the data transmission is not in error, that is, when the time period between each time out signal compared by the bit timing counter logic 1320 is below the predetermined time period, then the data bit associated with the current data communication is considered valid.

35 [0094] Referring still to FIG. 13, a clock signal is provided to the Manchester bit decoder logic 1310, the bit timing counter logic 1320 and the shift register logic 1340 to, among others, synchronize the operation of the various routines executed by the components of the close proximity detector logic in the transmitter unit of the analyte monitoring system. Additionally, in the manner described, the close proximity detector logic may be configured to use small logic blocks running at a relatively slower clock rate, resulting in, for example, reduction in the required ASIC resources and/or power consumption. Furthermore, the embodiments of the close proximity detector logic described above provides a standalone continuous OOK detection without the use of a microcontroller that requires relatively more power and ASIC resources (for example, ASIC area).

40 [0095] Indeed, in accordance with embodiments of the present disclosure, the transmitted OOK data packets from

the receiver unit (104/106) may be decoded in conjunction with the received close proximity commands using, for example, one or more of a Manchester decode block logic, error detection logics and a command decoder logic. Furthermore, while Manchester decoder logic is described above, within the scope of the present disclosure, other data encoding/decoding techniques may be used, for example, other binary phase-shift keying (BPSK).

5 **[0096]** FIG. 14 is a flow chart illustrating close proximity detection logic in one or more embodiments of the present disclosure. Referring to FIGS. 13 and 14, when a close proximity communication mode is activated in a data communication system for example, in the analyte monitoring system 100 (FIG. 1), the close proximity detector logic may be configured to continuously monitor to detect an incoming command or data signal. When the close proximity logic activated, an initial initialization occurs (1410) to clear data bits to ensure no incorrect signals are sent to the close proximity logic. The close proximity detector logic waits to receive one or more data packet (1420). As discussed above, the Manchester encoded data packets may be received at a rate of 4.8 Kbits/sec. When data is not received, the logic may time out and return to the initialization state (1410).

10 **[0097]** On the other hand, when the data packet is received, error correction is performed to determine the validity of the received data packet (1430). For example, as discussed above, the sequence detection logic may be configured to analyze the dotting pattern and the data frame of the received data packet to determine whether the data packet is valid. If it is determined that the analyzed dotting pattern and the data frame results in the detection of a particular sequence in the data pattern, then in one aspect, the routine may return to the reset/initialization state (1410). However, when it is determined that the received data packet is valid, the data packet is latched (1440), for example, in the shift register as discussed above. Indeed, when the 11th bit in the data packet is received, in one aspect, it is determined that the close proximity communication is completed (1460).

15 **[0098]** Referring to FIGS 13 and 14, the close proximity key is compared to confirm that the command received is intended for the transmitter device receiving the command (1450). For example, as discussed above in conjunction with FIG. 13, the data packet received may include a unique transmitter identification information (such as a serial number or other unique information). This information may be compared with a stored value to determine whether the information received matches the value stored. If it is determined that the close proximity key does not match, in one aspect, the routine returns to the initialization/reset state (1410), as the received data packet is not intended for the device that received the packet. On the other hand, if the close proximity key matches the stored information or unique value, in one aspect, the state machine logic may be configured to generate the OOK signal confirming the receipt of the valid close proximity communication, and the state machine logic may be configured to perform the requested function or execute the one or more routines associated with the received close proximity command.

20 **[0099]** In this manner, embodiments of the present disclosure provide method and apparatus for optimizing power consumption and ASIC resources in communication devices such as transmitter unit 620 of the analyte monitoring system described above, or on-body patch pump for infusing medication such as insulin, or other therapeutic agents.

25 **[0100]** It is to be noted that while exemplary embodiments described above include configurations that have specific data packet size, transmission rate, size of the shift register, error correction techniques, and the like, within the scope of the present disclosure, other suitable variations are fully contemplated.

30 **[0101]** A method in one aspect includes receiving an encoded data packet including one or more error detection bits, one or more close proximity commands, and a communication identifier, decoding the received data packet, performing error detection based on the one or more error detection bits, validating the decoded received data packet, and executing one or more routines associated with the respective one or more close proximity commands when the decoded received data packet is validated, where the executed one or more routines includes transmitting analyte related data.

35 **[0102]** The received data packet may be Manchester encoded.

[0103] The one or more error detection bits may include a predetermined bit pattern such as a dotting pattern, for example.

40 **[0104]** In a further aspect, decoding the received data packet may include performing Manchester decoding.

[0105] Also, validating the decoded received data packet may include comparing the received communication identifier in the data packet with a stored value.

[0106] The communication identifier may include a device identification information.

[0107] The one or more routines may be associated with the operation of an analyte monitoring device.

45 **[0108]** The executed one or more routines may include a power on routine, a power off routine, data transfer initiation routine, or data transfer disable routine.

[0109] The analyte related data may include a monitored analyte level, such as glucose level.

[0110] In a further aspect, the method may include storing the received data packet.

50 **[0111]** A method in accordance with another embodiment includes receiving an encoded data packet including a close proximity command and a communication identifier, decoding the received data packet, validating the decoded received data packet, and executing one or more routines associated with the respective one or more close proximity commands when the decoded received data packet is validated.

55 **[0112]** In one aspect, validating the decoded received data packet may include comparing the received communication

identifier in the data packet with a stored value.

[0113] Further, validating the decoded received data packet may include performing error detection on the data packet, including, for example, comparing one or more data pattern in the received data packet.

[0114] The communication identifier may include a device identification information.

[0115] The one or more routines may be associated with the operation of an analyte monitoring device.

[0116] The executed one or more routines may include a power on routine, a power off routine, data transfer initiation routine, or data transfer disable routine.

[0117] In still another aspect, the method may include receiving a signal associated with an analyte level, where the analyte includes glucose.

[0118] Also, the decoded received data packet may be stored in, for example, a memory, storage device, or the like.

[0119] An apparatus in accordance with still another embodiment includes a communication interface, one or more processors coupled to the communication interface, and a memory for storing instructions which, when executed by the one or more processors, causes the one or more processors to receive an encoded data packet including one or more error detection bits, one or more close proximity commands, and a communication identifier over the communication interface, decode the received data packet, perform error detection based on the one or more error detection bits, validate the decoded received data packet, and execute one or more routines associated with the respective one or more close proximity commands when the decoded received data packet is validated, wherein the executed one or more routines includes transmitting analyte related data.

[0120] The memory for storing instructions which, when executed by the one or more processors, may cause the one or more processors to Manchester decode the received data packet.

[0121] The one or more error detection bits may include a predetermined bit pattern including, for example, a dotting pattern.

[0122] The memory for storing instructions which, when executed by the one or more processors, may cause the one or more processors to Manchester decode the received data packet.

[0123] The memory for storing instructions which, when executed by the one or more processors, may cause the one or more processors to compare the received communication identifier in the data packet with a stored value to validate the received data packet.

[0124] The memory for storing instructions which, when executed by the one or more processors, may cause the one or more processors to store the received data packet in the memory.

[0125] The one or more processors may include an application specific integrated circuit (ASIC).

[0126] In the manner described, in accordance with embodiments of the present disclosure, the close proximity detector logic may be configured to use small logic blocks running at a relatively slower clock rate, resulting in, for example, reduction in the required ASIC area and power consumption. Furthermore, the embodiments of the close proximity detector logic described above provides a standalone continuous OOK detection without the use of a microcontroller that requires relatively more power and ASIC resources.

[0127] Various other modifications and alterations in the structure and method of operation of this invention will be apparent to those skilled in the art without departing from the scope of the invention. Although the invention has been described in connection with specific preferred embodiments, it should be understood that the invention as claimed should not be unduly limited to such specific embodiments. It is intended that the following claims define the scope of the present disclosure and that structures and methods within the scope of these claims and their equivalents be covered thereby.

Claims

1. A method, comprising:

establishing a communication range between a transmitter unit (102) and a receiver unit (104) by placing the receiver unit within a predetermined distance from the transmitter unit;

receiving an encoded data packet at the transmitter unit when the receiver unit is within the predetermined distance, the encoded data packet including at least one close proximity command and a communication identifier;

decoding the received data packet;

validating the decoded received data packet;

executing one or more routines associated with the respective one or more close proximity commands when the decoded received data packet is validated; **characterized in that**

the executed one or more routines includes transmitting analyte related data.

2. The method of Claim 1 wherein decoding the received data packet includes performing Manchester decoding.
3. The method of Claim 1 or Claim 2 wherein validating the decoded received data packet includes performing error detection on the data packet.
- 5 4. The method of Claim 3 wherein performing error detection includes comparing one or more data pattern in the received data packet.
- 10 5. The method of Claim 1 wherein the encoded data packet includes one or more error detection bits, and including the step of performing error detection based on the one or more error detection bits, the executed one or more routines including transmitting analyte related data.
6. The method of Claim 5 wherein the one or more error detection bits include a predetermined bit pattern.
- 15 7. The method of Claim 6 wherein the predetermined bit pattern includes a dotting pattern (1210).
8. The method of any of Claims 5 to 7 wherein decoding the received data packet includes performing Manchester decoding.
- 20 9. The method of any preceding Claim wherein the received data packet is Manchester encoded.
10. The method of any preceding Claim wherein validating the decoded received data packet includes comparing the received communication identifier in the data packet with a stored value.
- 25 11. The method of any preceding Claim wherein the communication identifier includes a device identification information.
12. The method of any preceding Claim wherein the one or more routines are associated with the operation of an analyte monitoring device.
- 30 13. The method of any preceding Claim wherein the executed one or more routines includes a power on routine, a power off routine, a data transfer initiation routine, or a data transfer disable routine.
14. The method of any preceding Claim including receiving a signal associated with an analyte level.
- 35 15. The method of Claim 14 wherein the analyte is glucose.
16. The method of any preceding Claim including storing the decoded received data packet.
17. The method of any preceding Claim, wherein transmitting analyte related data is performed periodically.
- 40 18. An apparatus (102), comprising:
 - a communication interface (201);
 - one or more processors (204) coupled to the communication interface; and
 - 45 a memory for storing instructions which, when executed by the one or more processors, causes the one or more processors to establish a communication range with a receiver unit when the receiver unit is placed within a predetermined distance, receive an encoded data packet when the receiver unit is within the predetermined distance, wherein the received encoded data packet includes one or more close proximity commands and a communication identifier over the communication interface, decode the received data packet, validate the de-
 - 50 coded received data packet, and execute one or more routines associated with the respective one or more close proximity commands when the decoded received data packet is validated, **characterized in that** the executed
 - one or more routines includes transmitting analyte related data.
- 55 19. The apparatus of Claim 18 wherein the memory for storing instructions which, when executed by the one or more processors, causes the one or more processors to compare the received communication identifier in the data packet with a stored value to validate the received data packet.

20. The apparatus of Claim 18 or Claim 19 wherein the communication identifier includes device identification information.
21. The apparatus of any of Claims 18 to 20 wherein the executed one or more routines includes a power on routine, a power off routine, a data transfer initiation routine, or a data transfer disable routine.
22. The apparatus of any of Claims 18 to 21 wherein the one or more processors include an application specific integrated circuit (ASIC).
23. The apparatus of any of Claims 18 to 22, wherein the one or more processors are configured to wirelessly communicate data over a radio frequency communication link.

Patentansprüche

1. Verfahren, das Folgendes beinhaltet:

Bestimmen einer Kommunikationsreichweite zwischen einer Sendereinheit (102) und einer Empfängereinheit (104) durch Platzieren der Empfängereinheit innerhalb einer vorbestimmten Distanz von der Sendereinheit; Empfangen eines encodierten Datenpakets an der Sendereinheit, wenn sich die Empfängereinheit innerhalb der vorbestimmten Distanz befindet, wobei das encodierte Datenpaket wenigstens einen Unmittelbare-Nähe-Befehl und eine Kommunikationskennung beinhaltet; Decodieren des empfangenen Datenpakets; Validieren des decodierten empfangenen Datenpakets; Ausführen von einer oder mehreren mit den jeweiligen ein oder mehreren Unmittelbare-Nähe-Befehlen assoziierten Routinen, wenn das decodierte empfangene Datenpaket validiert wird; **dadurch gekennzeichnet, dass** die ausgeführten ein oder mehreren Routinen das Senden von analytbezogenen Daten beinhalten.

2. Verfahren nach Anspruch 1, wobei das Decodieren des empfangenen Datenpakets das Ausführen von Manchester-Decodierung beinhaltet.
3. Verfahren nach Anspruch 1 oder Anspruch 2, wobei das Validieren des decodierten empfangenen Datenpakets das Ausführen von Fehlererkennung an dem Datenpaket beinhaltet.
4. Verfahren nach Anspruch 3, wobei das Ausführen von Fehlererkennung das Vergleichen von einem oder mehreren Datenmustern in dem empfangenen Datenpaket beinhaltet.
5. Verfahren nach Anspruch 1, wobei das encodierte Datenpaket ein oder mehrere Fehlererkennungsbits beinhaltet und den Schritt des Ausführens von Fehlererkennung auf der Basis der ein oder mehreren Fehlererkennungsbits beinhaltet, wobei die ausgeführten ein oder mehreren Routinen das Senden von analytbezogenen Daten beinhaltet.
6. Verfahren nach Anspruch 5, wobei die ein oder mehreren Fehlererkennungsbits ein vorbestimmtes Bitmuster beinhalten.
7. Verfahren nach Anspruch 6, wobei das vorbestimmte Bitmuster ein Punktmuster (1210) beinhaltet.
8. Verfahren nach einem der Ansprüche 5 bis 7, wobei das Decodieren des empfangenen Datenpakets das Ausführen von Manchester-Decodierung beinhaltet.
9. Verfahren nach einem vorherigen Anspruch, wobei das empfangene Datenpaket Manchester-encodiert ist.
10. Verfahren nach einem vorherigen Anspruch, wobei das Validieren des decodierten empfangenen Datenpakets das Vergleichen der empfangenen Kommunikationskennung in dem Datenpaket mit einem gespeicherten Wert beinhaltet.
11. Verfahren nach einem vorherigen Anspruch, wobei die Kommunikationskennung eine Geräteidentifikationsinformation beinhaltet.
12. Verfahren nach einem vorherigen Anspruch, wobei die ein oder mehreren Routinen mit dem Betrieb eines Analyt-

berwachungsgeräts assoziiert sind.

- 5
13. Verfahren nach einem vorherigen Anspruch, wobei die ausgeführten ein oder mehreren Routinen eine Stromeinschaltroutine, eine Stromausschaltroutine, eine Datenübertragungseinleitungsroutine oder eine Datenübertragungsperrroutine beinhalten.
- 10
14. Verfahren nach einem vorherigen Anspruch, das das Empfangen eines mit einem Analytspiegel assoziierten Signals beinhaltet.
- 15
15. Verfahren nach Anspruch 14, wobei der Analyt Glukose ist.
16. Verfahren nach einem vorherigen Anspruch, das das Speichern des decodierten empfangenen Datenpakets beinhaltet.
17. Verfahren nach einem vorherigen Anspruch, wobei das Senden von analytbezogenen Daten periodisch erfolgt.
18. Vorrichtung (102), die Folgendes umfasst:
- 20
- eine Kommunikationsschnittstelle (201);
- einen oder mehrere mit der Kommunikationsschnittstelle gekoppelte Prozessoren (204); und
- einen Speicher zum Speichern von Anweisungen, die bei Ausführung durch die ein oder mehreren Prozessoren bewirken, dass die ein oder mehreren Prozessoren eine Kommunikationsreichweite mit einer Empfängereinheit bestimmen, wenn die Empfängereinheit innerhalb einer vorbestimmten Distanz platziert wird, ein encodiertes Datenpaket empfangen, wenn sich die Empfängereinheit innerhalb der vorbestimmten Distanz befindet, wobei
- 25
- das empfangene encodierte Datenpaket einen oder mehrere Unmittelbare-Nähe-Befehle und eine Kommunikationskennung über die Kommunikationsschnittstelle enthalten, das empfangene Datenpaket decodieren, das decodierte empfangene Datenpaket validieren und eine oder mehrere mit den jeweiligen ein oder mehreren Unmittelbare-Nähe-Befehlen assoziierte Routinen ausführen, wenn das decodierte empfangene Datenpaket validiert ist, **dadurch gekennzeichnet, dass** die ausgeführten ein oder mehreren Routinen das Senden von
- 30
- analytbezogenen Daten beinhalten.
19. Vorrichtung nach Anspruch 18, wobei der Speicher zum Speichern von Anweisungen, die bei Ausführung durch die ein oder mehreren Prozessoren bewirken, dass die ein oder mehreren Prozessoren die empfangene Kommunikationskennung in dem Datenpaket mit einem gespeicherten Wert vergleichen, um das empfangene Datenpaket zu validieren.
- 35
20. Vorrichtung nach Anspruch 18 oder Anspruch 19, wobei die Kommunikationskennung Geräteidentifikationsinformationen beinhaltet.
- 40
21. Vorrichtung nach einem der Ansprüche 18 bis 20, wobei die ausgeführten ein oder mehreren Routinen eine Stromeinschaltroutine, eine Stromausschaltroutine, eine Datenübertragungseinleitungsroutine oder eine Datenübertragungsperrroutine beinhalten.
- 45
22. Vorrichtung nach einem der Ansprüche 18 bis 21, wobei die ein oder mehreren Prozessoren eine anwendungsspezifische integrierte Schaltung (ASIC) beinhalten.
23. Vorrichtung nach einem der Ansprüche 18 bis 22, wobei die ein oder mehreren Prozessoren zum drahtlosen Kommunizieren von Daten über eine Funkfrequenzkommunikationsverbindung konfiguriert sind.

50

Revendications

1. Procédé comprenant les étapes consistant à :

55

établir une portée de communication entre une unité émettrice (102) et une unité réceptrice (104) en plaçant l'unité réceptrice dans un rayon prédéterminé de l'unité émettrice ; recevoir un paquet de données codé au niveau de l'unité émettrice quand l'unité réceptrice est dans le rayon prédéterminé, le paquet de données codé comprenant au moins une commande de champ proche et un identifiant de communication ;

EP 2 280 636 B1

décoder le paquet de données reçu ;
valider le paquet de données reçu décodé ;
exécuter un ou plusieurs programmes associés à la ou aux commandes de champ proche respectives quand le paquet de données reçu décodé est validé ;

5

caractérisé en ce que le ou les programmes exécutés consistent à transmettre des données relatives à un analyte.

2. Procédé selon la revendication 1, dans lequel le décodage du paquet de données reçu consiste à réaliser un décodage Manchester.

10

3. Procédé selon la revendication 1 ou 2, dans lequel la validation du paquet de données reçu décodé consiste à réaliser une détection d'erreur sur le paquet de données.

15

4. Procédé selon la revendication 3, dans lequel la réalisation d'une détection d'erreur consiste à comparer un ou plusieurs schémas de données dans le paquet de données reçu.

5. Procédé selon la revendication 1, dans lequel le paquet de données codé comprend un ou plusieurs bits de détection d'erreur, et comprenant l'étape consistant à réaliser une détection d'erreur sur la base du ou des bits de détection d'erreur, le ou les programmes exécutés consistant à transmettre des données relatives à un analyte.

20

6. Procédé selon la revendication 5, dans lequel le ou les bits de détection d'erreur comprennent un schéma binaire prédéterminé.

7. Procédé selon la revendication 6, dans lequel le schéma binaire prédéterminé comprend une suite de points (1210).

25

8. Procédé selon l'une quelconque des revendications 5 à 7, dans lequel le décodage du paquet de données reçu consiste à réaliser un décodage Manchester.

9. Procédé selon l'une quelconque des revendications précédentes, dans lequel le paquet de données reçu est codé en code Manchester.

30

10. Procédé selon l'une quelconque des revendications précédentes, dans lequel la validation du paquet de données reçu décodé consiste à comparer l'identifiant de communication reçu dans le paquet de données à une valeur stockée.

35

11. Procédé selon l'une quelconque des revendications précédentes, dans lequel l'identifiant de communication comprend une information d'identification de dispositif.

12. Procédé selon l'une quelconque des revendications précédentes, dans lequel le ou les programmes sont associés au fonctionnement d'un dispositif de surveillance d'analyte.

40

13. Procédé selon l'une quelconque des revendications précédentes, dans lequel le ou les programmes exécutés comprennent un programme de mise sous tension, un programme de mise hors tension, un programme d'amorçage de transfert de données ou un programme de désactivation de transfert de données.

45

14. Procédé selon l'une quelconque des revendications précédentes, consistant à recevoir un signal associé à un niveau d'analyte.

15. Procédé selon la revendication 14, dans lequel l'analyte est le glucose.

50

16. Procédé selon l'une quelconque des revendications précédentes, consistant à stocker le paquet de données reçu décodé.

17. Procédé selon l'une quelconque des revendications précédentes, dans lequel la transmission des données relatives à l'analyte est effectuée périodiquement.

55

18. Appareil (102) comprenant :

EP 2 280 636 B1

une interface de communication (201) ;
un ou plusieurs processeurs (204) couplés à l'interface de communication ; et
une mémoire permettant de stocker des instructions qui, lorsqu'elles sont exécutées par le ou les processeurs,
amènent le ou les processeurs à établir une portée de communication avec une unité réceptrice quand l'unité
5 réceptrice est placée dans un rayon prédéterminé, recevoir un paquet de données codé quand l'unité réceptrice
est dans le rayon prédéterminé, le paquet de données codé reçu comprenant une ou plusieurs commandes de
champ proche et un identifiant de communication sur l'interface de communication, décoder le paquet de
données reçu, valider le paquet de données reçu décodé, et exécuter un ou plusieurs programmes associés
à la ou aux commandes de champ proche respectives quand le paquet de données reçu décodé est validé,
10 **caractérisé en ce que** le ou les programmes exécutés consistent à transmettre des données relatives à un
analyte.

19. Appareil selon la revendication 18, dans lequel la mémoire stocke des instructions qui, lorsqu'elles sont exécutées
par le ou les processeurs, amènent le ou les processeurs à comparer l'identifiant de communication reçu dans le
15 paquet de données à une valeur stockée afin de valider le paquet de données reçu.

20. Appareil selon la revendication 18 ou 19, dans lequel l'identifiant de communication comprend une information
d'identification de dispositif.

21. Appareil selon l'une quelconque des revendications 18 à 20, dans lequel le ou les programmes exécutés comprennent
un programme de mise sous tension, un programme de mise hors tension, un programme d'amorçage de transfert
de données ou un programme de désactivation de transfert de données.

22. Appareil selon l'une quelconque des revendications 18 à 21, dans lequel le ou les processeurs comprennent un
25 circuit intégré à application spécifique (ASIC).

23. Appareil selon l'une quelconque des revendications 18 à 22, dans lequel le ou les processeurs sont conçus pour
communiquer sans fil des données sur une liaison de communication par radiofréquence.

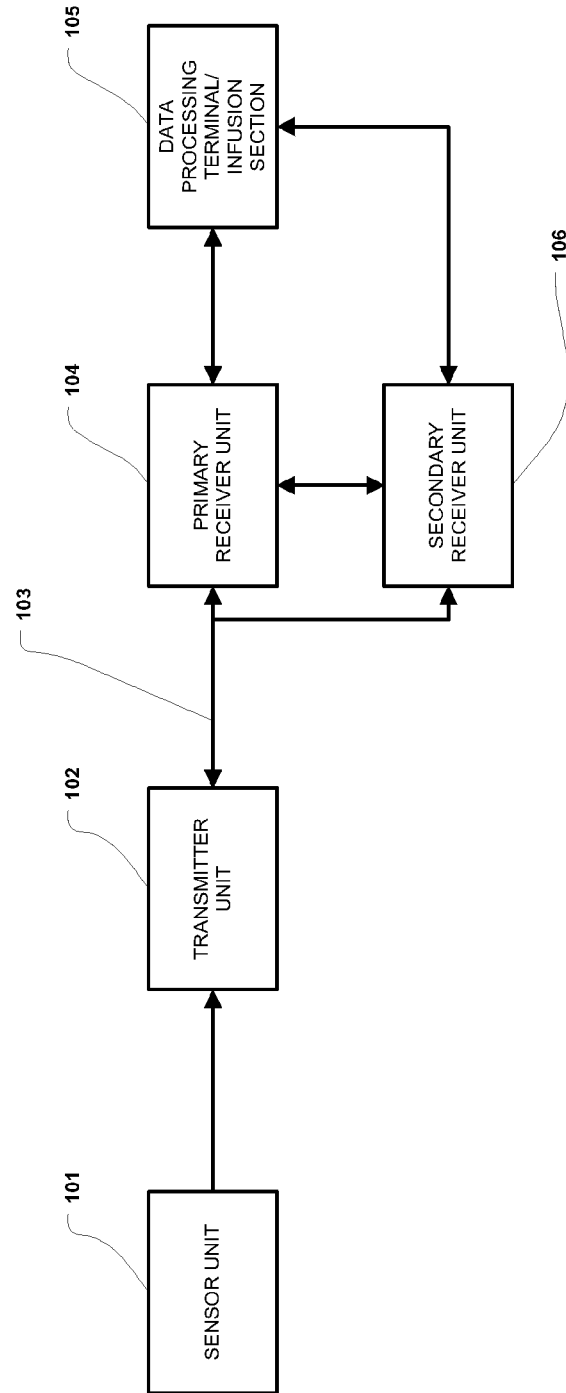

100

FIGURE 1

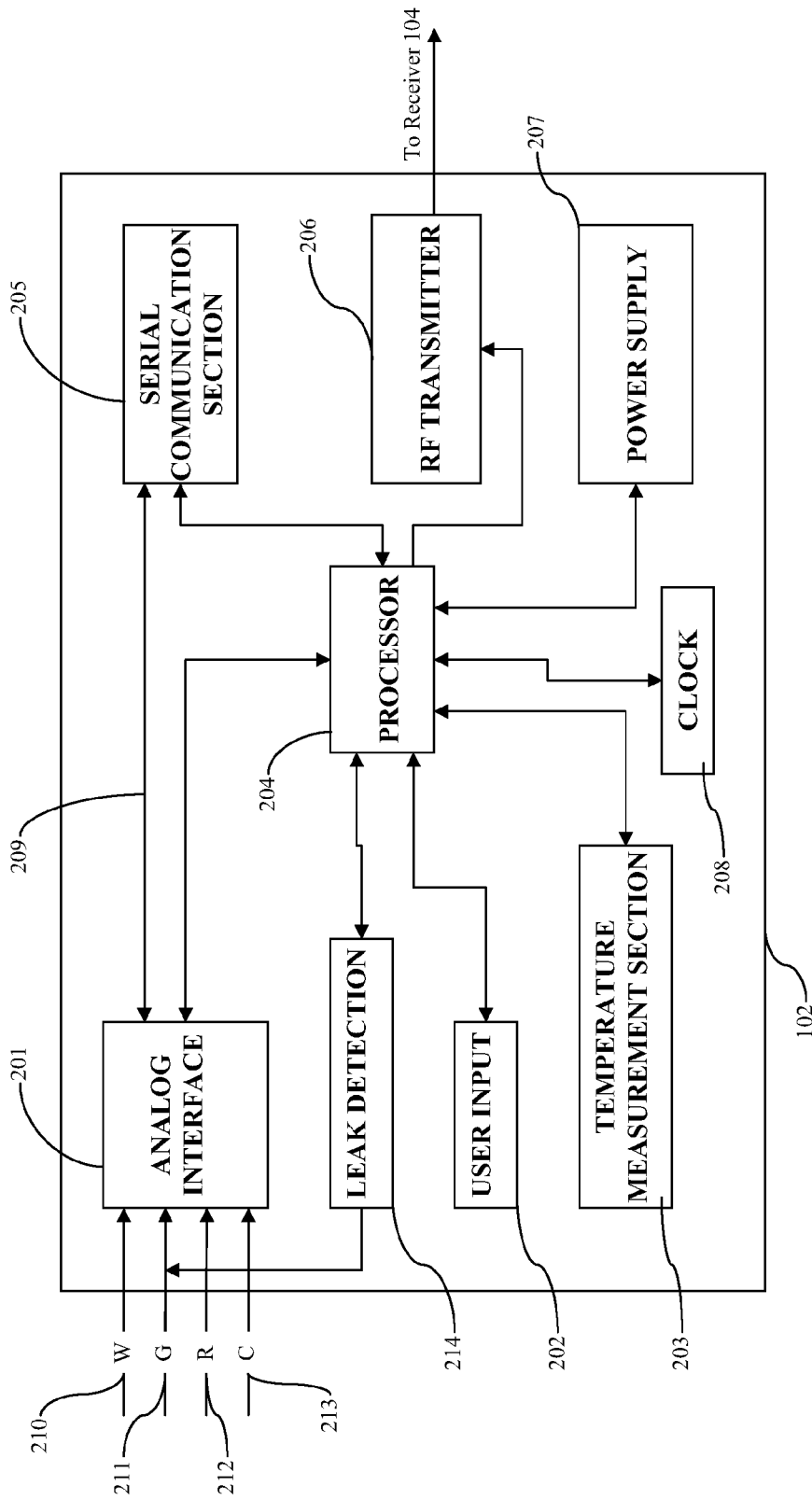

FIGURE 2

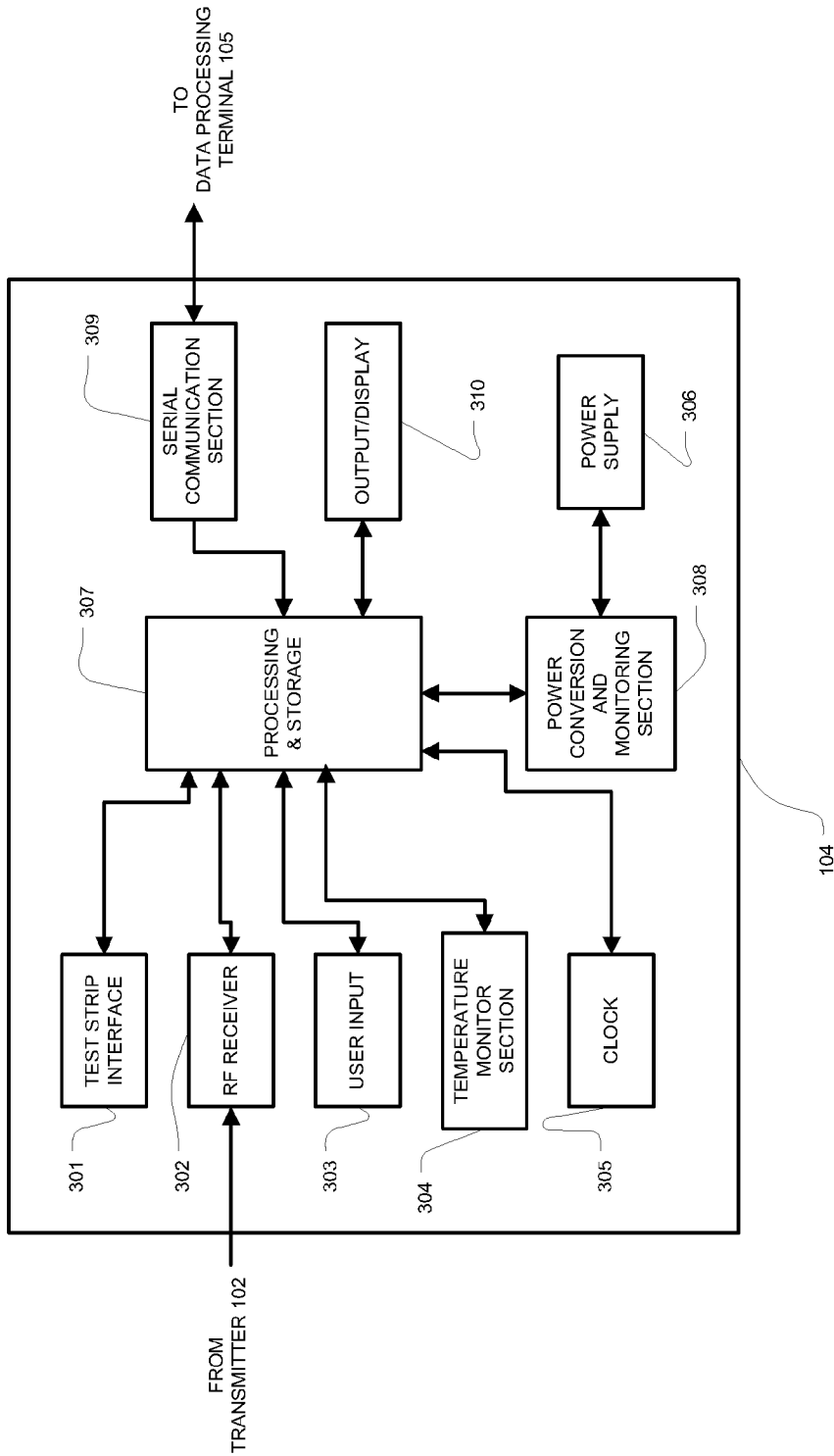

FIGURE 3

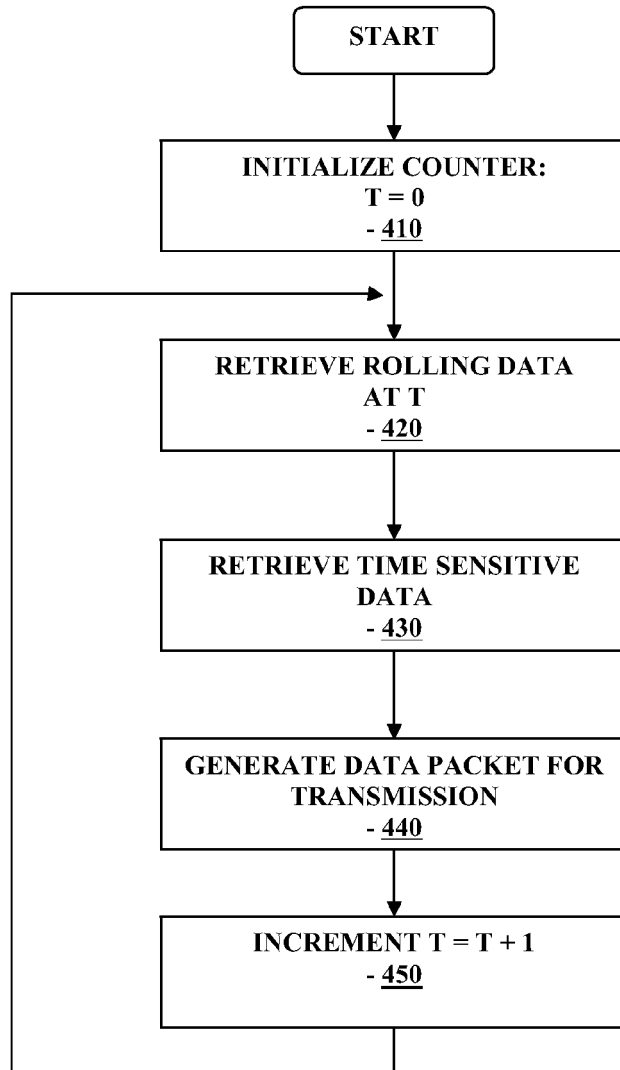

FIGURE 4

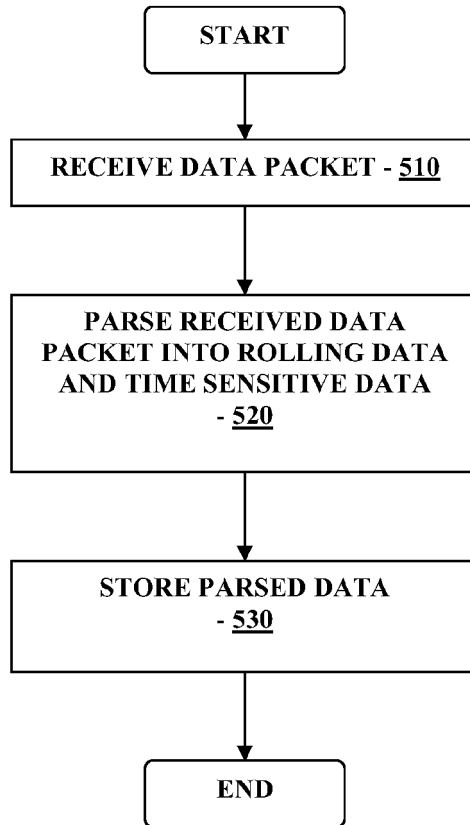

FIGURE 5

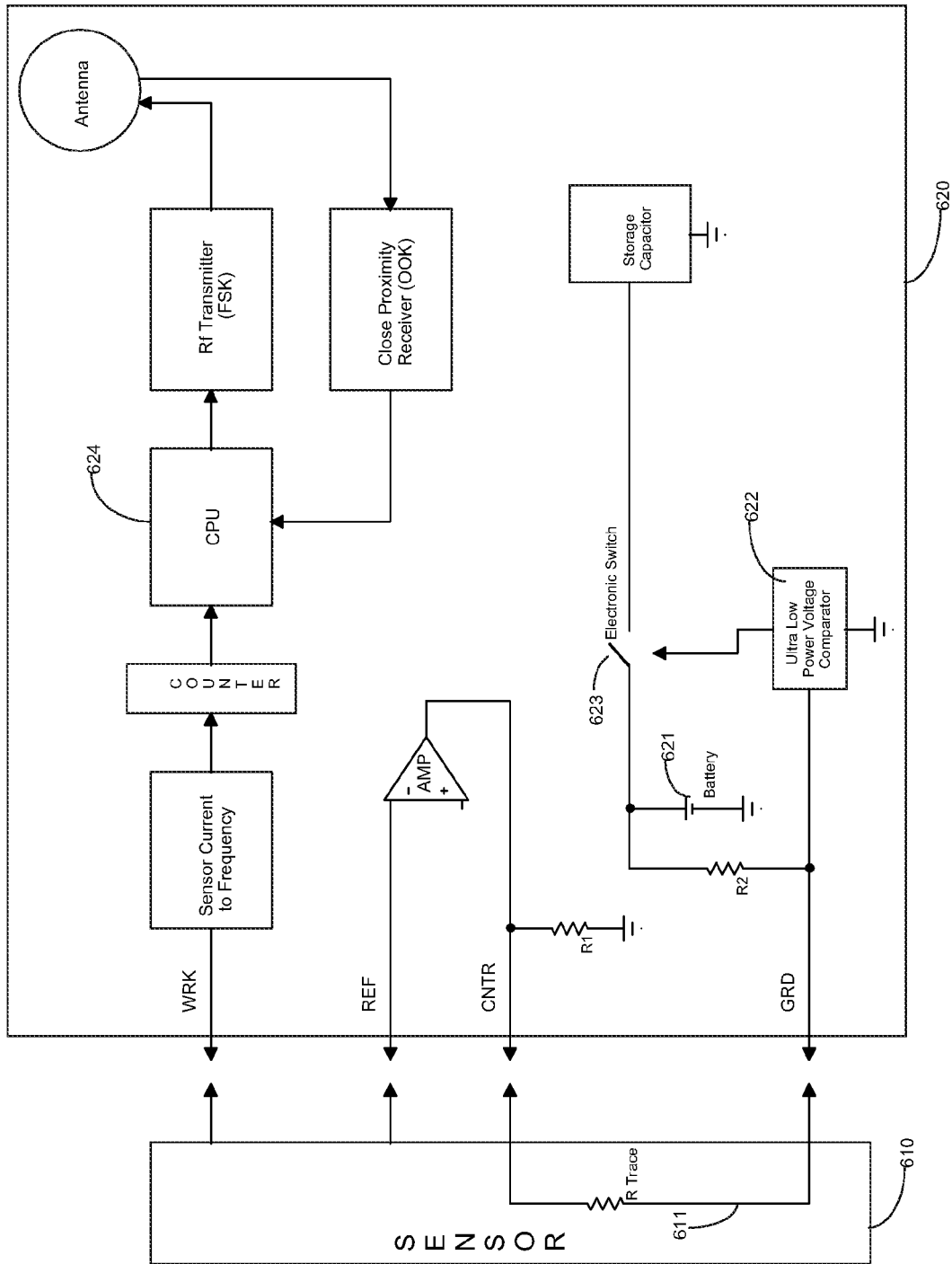

FIGURE 6

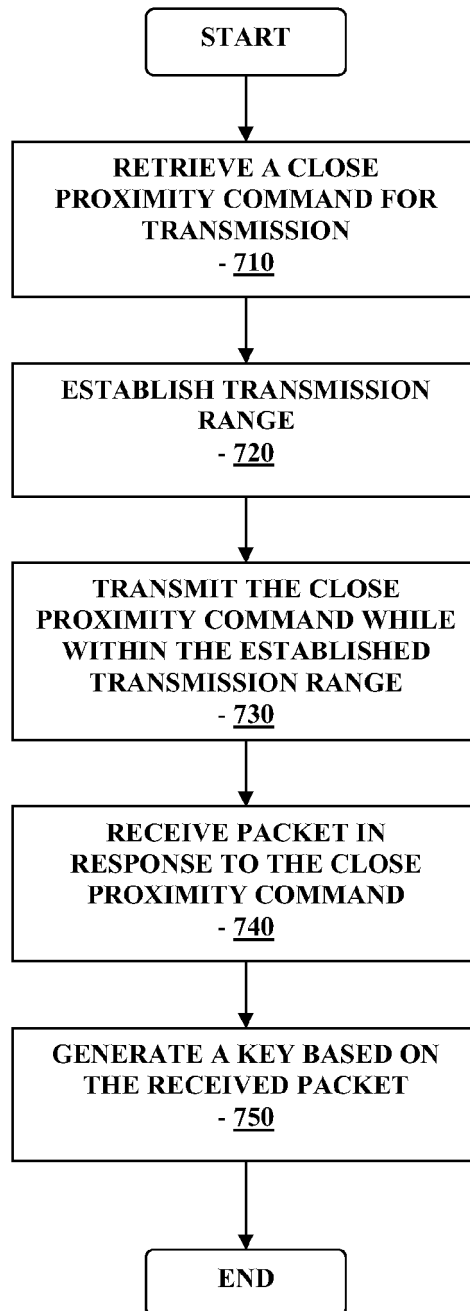

FIGURE 7

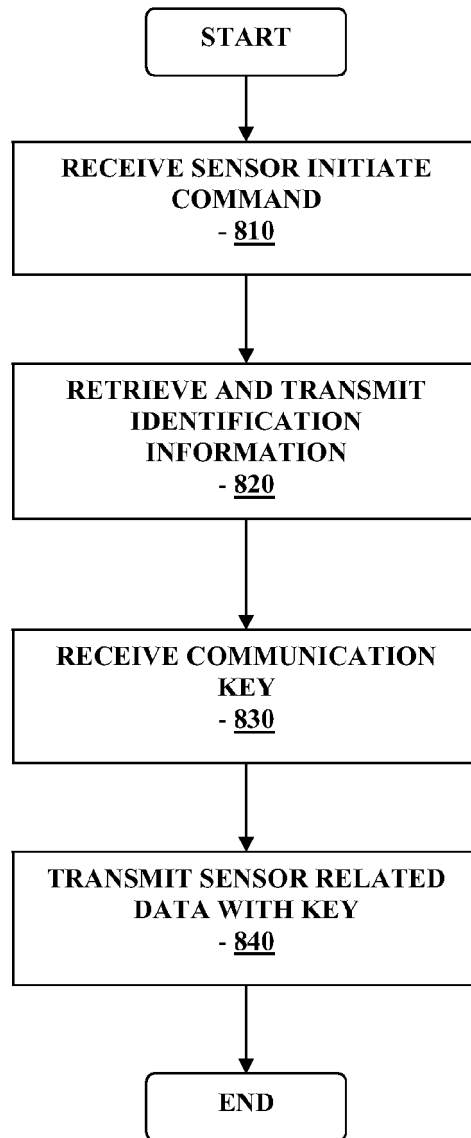

FIGURE 8

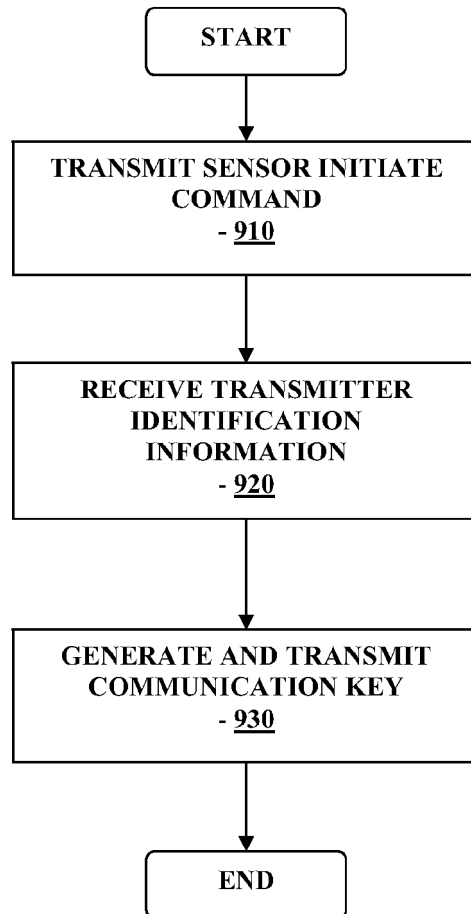

FIGURE 9

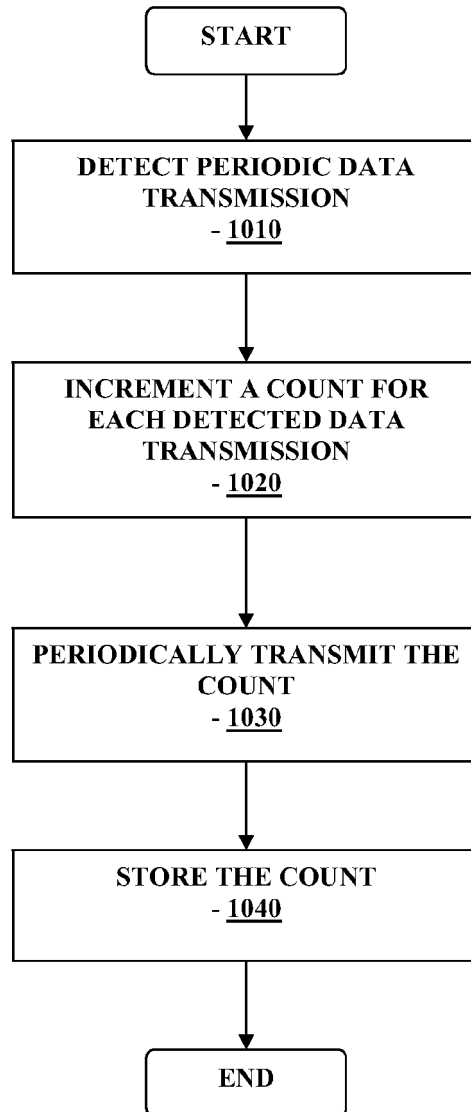

FIGURE 10

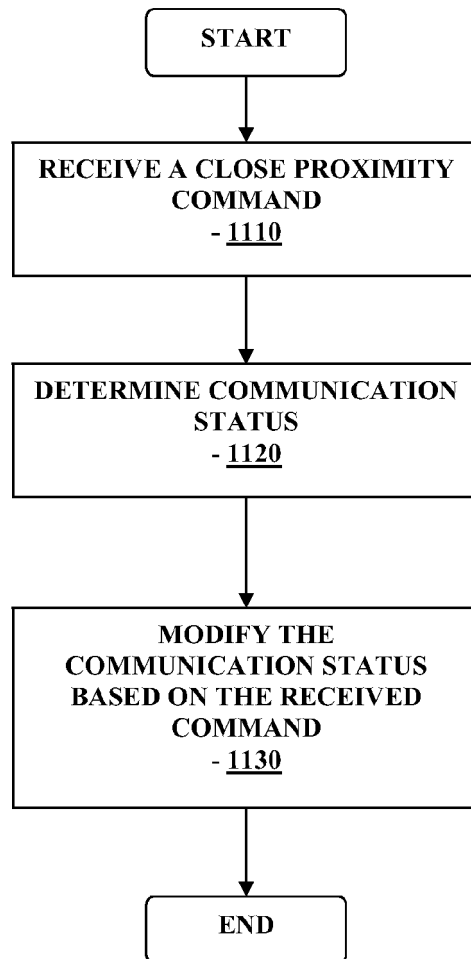

FIGURE 11

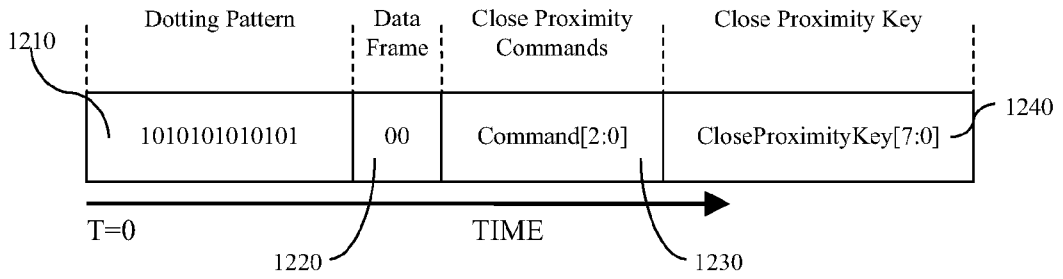

FIGURE 12

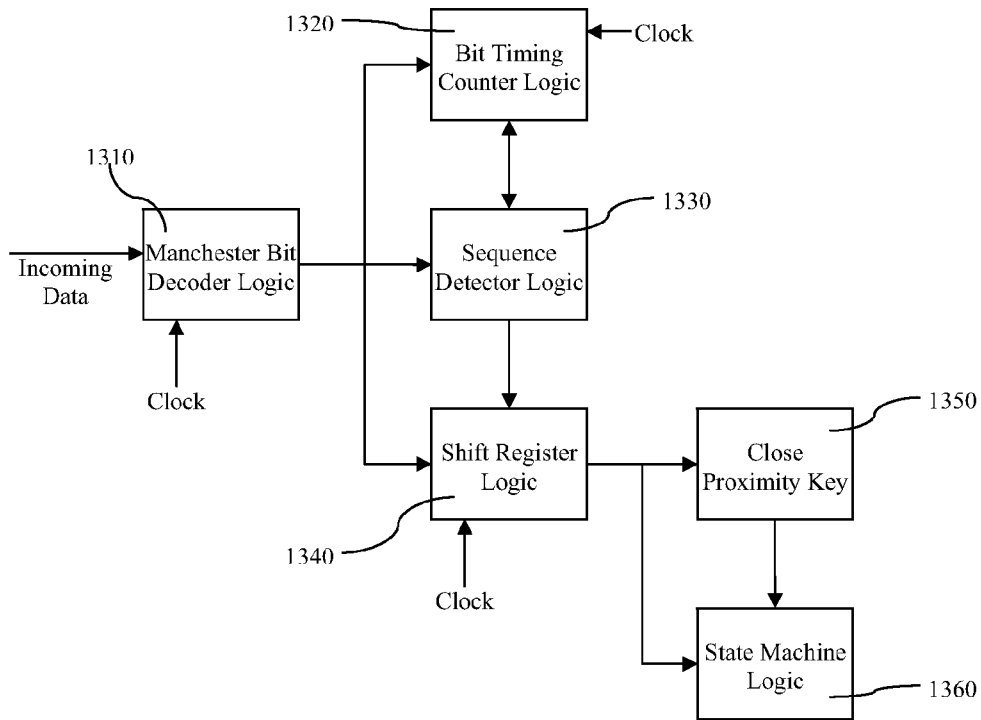

FIGURE 13

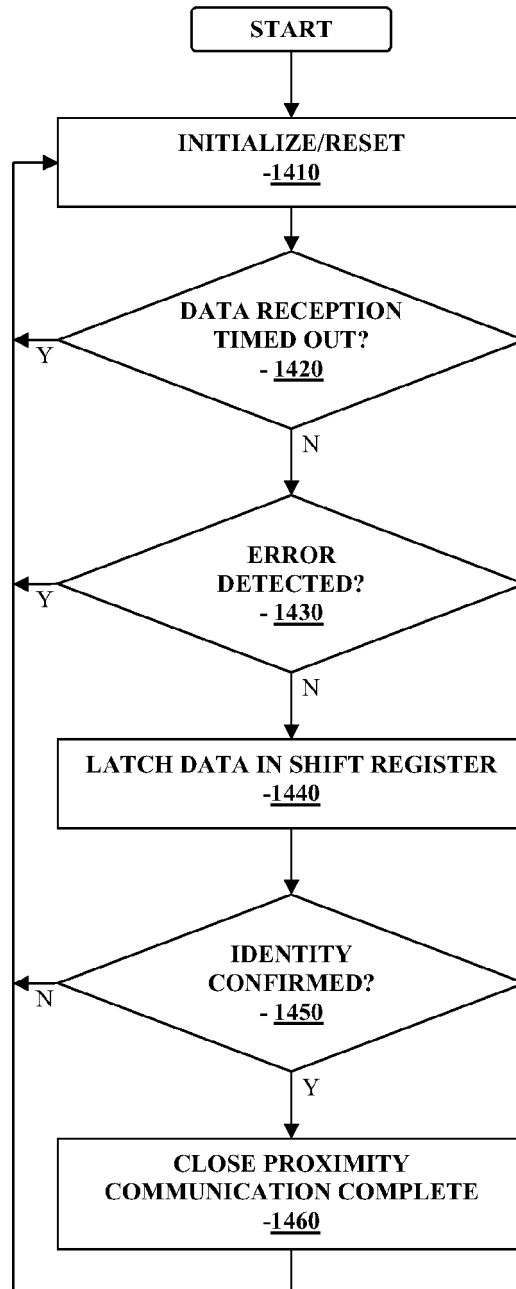

FIGURE 14

REFERENCES CITED IN THE DESCRIPTION

This list of references cited by the applicant is for the reader's convenience only. It does not form part of the European patent document. Even though great care has been taken in compiling the references, errors or omissions cannot be excluded and the EPO disclaims all liability in this regard.

Patent documents cited in the description

- US 13099508 A [0001]
- WO 2008138006 A2 [0007]
- CA 2605530 A1 [0008]
- WO 2006064397 A2 [0008]
- US 2006293607 A1 [0008]
- US 6134461 A [0033]
- US 6175752 B [0033] [0064]
- US 6121611 A [0033]
- US 6560471 B [0033]
- US 6746582 B [0033]
- WO 11060365 A [0039]

Non-patent literature cited in the description

- Flexible Communication and Control Protocol for Injectable Neuromuscular Interfaces. **RODRIGUEZ N et al.** IEEE TRANSACTIONS ON BIOMEDICAL CIRCUITS AND SYSTEMS. IEEE, 01 March 2007, vol. 1, 19-27 [0006]

专利名称(译)	近距离通信设备和方法		
公开(公告)号	EP2280636A4	公开(公告)日	2012-04-11
申请号	EP2009755752	申请日	2009-05-28
[标]申请(专利权)人(译)	雅培糖尿病护理公司		
申请(专利权)人(译)	雅培糖尿病INC.		
当前申请(专利权)人(译)	雅培糖尿病INC.		
[标]发明人	SICURELLO JEFFREY SLOAN MARK K		
发明人	SICURELLO, JEFFREY SLOAN, MARK, K.		
IPC分类号	A61B5/00		
CPC分类号	A61B5/0002 A61B5/14532 A61B5/14546 A61B5/7232 A61B2560/0209 A61B5/0004 G06K7/10405 H04L1/0046 H04L1/0061		
优先权	12/130995 2008-05-30 US		
其他公开文献	EP2280636A1 EP2280636B1		
外部链接	Espacenet		

摘要(译)

公开了用于在医疗系统中提供近距离检测的方法和设备。