



(11) **EP 1 890 597 B1**

(12) **EUROPEAN PATENT SPECIFICATION**

(45) Date of publication and mention of the grant of the patent:
22.02.2012 Bulletin 2012/08

(21) Application number: **06760592.3**

(22) Date of filing: **31.05.2006**

(51) Int Cl.:
A61B 5/05^(2006.01) A61B 5/00^(2006.01)

(86) International application number:
PCT/US2006/021113

(87) International publication number:
WO 2006/132884 (14.12.2006 Gazette 2006/50)

(54) **METHOD AND APPARATUS FOR PROVIDING RECHARGEABLE POWER IN DATA MONITORING AND MANAGEMENT SYSTEMS**

VERFAHREN UND GERÄT ZUR LIEFERUNG VON WIEDER AUFLADBARER ENERGIE IN DATENÜBERWACHUNGS- UND VERWALTUNGSSYSTEMEN

PROCEDE ET APPAREIL POUR LA FOURNITURE D'ENERGIE RECHARGEABLE DANS DES SYSTEMES DE CONTROLE ET DE GESTION DE DONNEES

(84) Designated Contracting States:
AT BE BG CH CY CZ DE DK EE ES FI FR GB GR HU IE IS IT LI LT LU LV MC NL PL PT RO SE SI SK TR

(30) Priority: **03.06.2005 US 145048**

(43) Date of publication of application:
27.02.2008 Bulletin 2008/09

(73) Proprietor: **Abbott Diabetes Care Inc.**
Alameda, CA 94502 (US)

(72) Inventor: **REGGIARDO, Christopher, V.**
Castro Valley, CA 94546 (US)

(74) Representative: **Horton, Andrew Robert Grant**
Bowles Horton
Felden House
Dower Mews
High Street
Berkhamsted, Hertfordshire HP4 2BL (GB)

(56) References cited:
US-A- 6 144 869 US-A1- 2003 168 335
US-A1- 2005 277 844 US-B1- 6 185 452
US-B2- 7 136 704

EP 1 890 597 B1

Note: Within nine months of the publication of the mention of the grant of the European patent in the European Patent Bulletin, any person may give notice to the European Patent Office of opposition to that patent, in accordance with the Implementing Regulations. Notice of opposition shall not be deemed to have been filed until the opposition fee has been paid. (Art. 99(1) European Patent Convention).

Description

[0001] The present invention relates to data monitoring and management systems. More specifically, the present invention relates to a method and apparatus for providing rechargeable power used in data monitoring systems such as glucose monitoring systems.

[0002] Glucose monitoring systems including continuous and discrete monitoring systems generally include a small, lightweight battery powered and microprocessor controlled system which is configured to detect signals proportional to the corresponding measured glucose levels using an electrometer, and RF signals to transmit the collected data. One aspect of such glucose monitoring systems include a sensor configuration which is, for example, mounted on the skin of a subject whose glucose level is to be monitored. The sensor cell may use a three-electrode (work, reference and counter electrodes) configuration driven by a controlled potential (potentiostat) analog circuit connected through a contact system.

[0003] The battery providing power to the microprocessor controlled system is typically configured for a limited duration usage, and thus would require periodic replacement. Furthermore, given the compact size of the system, as well as the need for water tight seals, it is not desirable to have removable components such as battery covers or additional electrical contacts that may be exposed to the environment or to the patient's skin without the addition of seals and covers.

[0004] In view of the foregoing, it would be desirable to have an approach to readily and easily provide rechargeable power to the battery in the microprocessor controlled system.

[0005] The invention is defined by the independent claims 1 and 5, which are partitioned relative to the document US-B1-0185452.

[0006] In view of the foregoing, in accordance with the various embodiments of the present invention, there is provided a method and apparatus for charging the battery through the existing analog electrical contacts (electrodes) using the ESD protection circuitry.

[0007] More specifically, in one embodiment of the present invention, using the guard and the counter electrodes coupled to the transmitter unit of the data monitoring and management system, the power supply of the transmitter unit may be recharged so that the power supply need not be repeatedly replenished when it has been depleted of power and can not support reliable system operation.

BRIEF DESCRIPTION OF THE DRAWINGS

[0008]

FIG. 1 illustrates a block diagram of a data monitoring and management system for practicing one embodiment of the present invention;

FIG. 2 is a block diagram of the transmitter of the

data monitoring and management system shown in FIG. 1 in accordance with one embodiment of the present invention;

FIG. 3 illustrates the front end section of the analog interface of the transmitter in accordance with one embodiment of the present invention;

FIGS. 4A-4B respectively show detailed illustrations of the current to voltage circuit and the counter-reference servo circuit of the analog interface shown in FIG. 3 in accordance with one embodiment of the present invention;

FIG. 5 illustrates the battery recharging circuit in accordance with one embodiment of the present invention;

FIG. 6 illustrates the battery recharging circuit in accordance with another embodiment of the present invention; and

FIGS. 7A-7B illustrates inductive battery recharging in accordance with alternate embodiments of the present invention.

DETAILED DESCRIPTION

[0009] FIG. 1 illustrates a data monitoring and management system such as, for example, a glucose monitoring system 100 in accordance with one embodiment of the present invention. In such embodiment, the glucose monitoring system 100 includes a sensor 101, a transmitter 102 coupled to the sensor 101, and a receiver 104 which is configured to communicate with the transmitter 102 via a communication link 103. The receiver 104 may be further configured to transmit data to a data processing terminal 105 for evaluating the data received by the receiver 104. Only one sensor 101, transmitter 102, communication link 103, receiver 104, and data processing terminal 105 are shown in the embodiment of the glucose monitoring system 100 illustrated in FIG. 1. However, it will be appreciated by one of ordinary skill in the art that the glucose monitoring system 100 may include one or more sensor 101, transmitter 102, communication link 103, receiver 104, and data processing terminal 105, where each receiver 104 is uniquely synchronized with a respective transmitter 102. Moreover, within the scope of the present invention, the glucose monitoring system 100 may be a continuous monitoring system, or a semi-continuous or discrete monitoring system.

[0010] In one embodiment of the present invention, the sensor 101 is physically positioned on the body of a user whose glucose level is being monitored. The sensor 101 may be configured to continuously sample the glucose level of the user and convert the sampled glucose level into a corresponding data signal for transmission by the transmitter 102. In one embodiment, the transmitter 102 is mounted on the sensor 101 so that both devices are positioned on the user's body. The transmitter 102 performs data processing such as filtering and encoding on data signals, each of which corresponds to a sampled

glucose level of the user, for transmission to the receiver 104 via the communication link 103.

[0011] In one embodiment, the glucose monitoring system 100 is configured as a one-way RF communication path from the transmitter 102 to the receiver 104. In such embodiment, the transmitter 102 transmits the sampled data signals received from the sensor 101 without acknowledgement from the receiver 104 that the transmitted sampled data signals have been received. For example, the transmitter 102 may be configured to transmit the encoded sampled data signals at a fixed rate (e.g., at one minute intervals) after the completion of the initial power on procedure. Likewise, the receiver 104 may be configured to detect such transmitted encoded sampled data signals at predetermined time intervals. Alternatively, the glucose monitoring system 10 may be configured with a bi-directional RF communication between the transmitter 102 and the receiver 104.

[0012] Additionally, in one aspect, the receiver 104 may include two sections. The first section is an analog interface section that is configured to communicate with the transmitter 102 via the communication link 103. In one embodiment, the analog interface section may include an RF receiver and an antenna for receiving and amplifying the data signals from the transmitter 102, which are thereafter, demodulated with a local oscillator and filtered through a band-pass filter. The second section of the receiver 104 is a data processing section which is configured to process the data signals received from the transmitter 102 such as by performing data decoding, error detection and correction, data clock generation, and data bit recovery.

[0013] In operation, upon completing the power-on procedure, the receiver 104 is configured to detect the presence of the transmitter 102 within its range based on, for example, the strength of the detected data signals received from the transmitter 102 or a predetermined transmitter identification information. Upon successful synchronization with the corresponding transmitter 102, the receiver 104 is configured to begin receiving from the transmitter 102 data signals corresponding to the user's detected glucose level. More specifically, the receiver 104 in one embodiment is configured to perform synchronized time hopping with the corresponding synchronized transmitter 102 via the communication link 103 to obtain the user's detected glucose level.

[0014] Referring again to FIG. 1, the data processing terminal 105 may include a personal computer, a portable computer such as a laptop or a handheld device (e.g., personal digital assistants (PDAs)), and the like, each of which may be configured for data communication with the receiver via a wired or a wireless connection. Additionally, the data processing terminal 105 may further be connected to a data network (not shown) for storing, retrieving and updating data corresponding to the detected glucose level of the user.

[0015] Within the scope of the present invention, the data processing terminal 105 may include an infusion

device such as an insulin infusion pump, which may be configured to administer insulin to patients, and which is configured to communicate with the receiver unit 104 for receiving, among others, the measured glucose level. Alternatively, the receiver unit 104 may be configured to integrate an infusion device therein so that the receiver unit 104 is configured to administer insulin therapy to patients, for example, for administering and modifying basal profiles, as well as for determining appropriate boluses for administration based on, among others, the detected glucose levels received from the transmitter 102.

[0016] FIG. 2 is a block diagram of the transmitter of the data monitoring and detection system shown in FIG. 1 in accordance with one embodiment of the present invention. Referring to the Figure, the transmitter 102 in one embodiment includes an analog interface 201 configured to communicate with the sensor 101 (FIG. 1), a user input 202, and a temperature detection section 203, each of which is operatively coupled to a transmitter processor 204 such as a central processing unit (CPU). As can be seen from FIG. 2, there are provided four contacts, three of which are electrodes - work electrode (W) 210, guard contact (G) 211, reference electrode (R) 212, and counter electrode (C) 213, each operatively coupled to the analog interface 201 of the transmitter 102 for connection to the sensor unit 201 (FIG. 1). In one embodiment, each of the work electrode (W) 210, guard contact (G) 211, reference electrode (R) 212, and counter electrode (C) 213 may be made using a conductive material that is either printed or etched, for example, such as carbon which may be printed, or metal foil (e.g., gold) which may be etched.

[0017] Further shown in FIG. 2 are a transmitter serial communication section 205 and an RF transmitter 206, each of which is also operatively coupled to the transmitter processor 204. Moreover, a power supply 207 such as a battery, including a rechargeable battery, is also provided in the transmitter 102 to provide the necessary power for the transmitter 102 where the guard contact (G) 211 and the counter electrode (C) 213 are configured to couple to the power supply 207 through ESD clamp diodes (in the analog interface 201). Additionally, as can be seen from the Figure, clock 208 is provided to, among others, supply real time information to the transmitter processor 204. As discussed in further detail below, the power supply 207 may be configured to be recharged via a select pair of the plurality of electrodes 210-213 such as the guard contact 211 and counter electrode 213, when the transmitter unit 102 is not mounted to a patient and configured for periodic transmission of measured data to the receiver unit 103. As further discussed below, the power supply 207 may be coupled or docked to a battery charging station or unit during the recharge process, where the power supply 207 is recharged and, thereafter, when the transmitter unit 102 is mounted to the patient and coupled to the sensor 101, the power supply 207 may be configured to provide the necessary power to reliably operate the transmitter unit 102.

[0018] Referring back to the Figures, in one embodiment, a unidirectional input path is established from the sensor 101 (FIG. 1) and/or manufacturing and testing equipment to the analog interface 201 of the transmitter 102, while a unidirectional output is established from the output of the RF transmitter 206 of the transmitter 102 for transmission to the receiver 104. In this manner, a data path is shown in FIG. 2 between the aforementioned unidirectional input and output via a dedicated link 209 from the analog interface 201 to serial communication section 205, thereafter to the processor 204, and then to the RF transmitter 206. As such, in one embodiment, via the data path described above, the transmitter 102 is configured to transmit to the receiver 104 (FIG. 1), via the communication link 103 (FIG. 1), processed and encoded data signals received from the sensor 101 (FIG. 1). Additionally, the unidirectional communication data path between the analog interface 201 and the RF transmitter 206 discussed above allows for the configuration of the transmitter 102 for operation upon completion of the manufacturing process as well as for direct communication for diagnostic and testing purposes.

[0019] As discussed above, the transmitter processor 204 is configured to transmit control signals to the various sections of the transmitter 102 during the operation of the transmitter 102. In one embodiment, the transmitter processor 204 also includes a memory (not shown) for storing data such as the identification information for the transmitter 102, as well as the data signals received from the sensor 101. The stored information may be retrieved and processed for transmission to the receiver 104 under the control of the transmitter processor 204. Furthermore, the power supply 207 may include a commercially available non-rechargeable battery or a proprietary or commercially available rechargeable battery.

[0020] The transmitter 102 is also configured such that the power supply section 207 does not significantly affect the battery life after having been stored for 18 months in a low-power (non-operating) mode. In one embodiment, this may be achieved by the transmitter processor 204 operating in low power modes in the non-operating state, for example, drawing no more than approximately 1 μ A of current. Indeed, in one embodiment, the final step during the manufacturing process of the transmitter 102 may place the transmitter 102 in the lower power, non-operating state (i.e., post-manufacture sleep mode). In this manner, the shelf life of the transmitter 102 may be significantly improved.

[0021] Referring yet again to FIG. 2, the temperature detection section 203 of the transmitter 102 is configured to monitor the temperature of the skin near the sensor insertion site. The temperature reading is used to adjust the glucose readings obtained from the analog interface 201. The RF transmitter 206 of the transmitter 102 may be configured for operation in the frequency band of 315 MHz to 322 MHz, for example, in the United States. Further, in one embodiment, the RF transmitter 206 is configured to modulate the carrier frequency by performing

Frequency Shift Keying and Manchester encoding. In one embodiment, the data transmission rate is 19,200 symbols per second, with a minimum transmission range for communication with the receiver 104.

[0022] Additional detailed description of the continuous glucose monitoring system, its various components including the functional descriptions of the transmitter are provided in U.S. Patent No. 6,175,752 issued January 16, 2001 entitled "Analyte Monitoring Device and Methods of Use", and in application No. 10/745,878 filed December 26, 2003 entitled "Continuous Glucose Monitoring System and Methods of Use", each assigned to the Assignee of the present application, and the disclosures of each of which are incorporated herein by reference for all purposes.

[0023] FIG. 3 illustrates the front end section of the analog interface of the transmitter in accordance with one embodiment of the present invention. Referring to the Figure, the front end section of the analog interface 201 includes a current to voltage circuit 301 which is configured to operatively couple to the work electrode 210 and the guard contact 211, and a counter-reference servo circuit 302 which is configured to operatively couple to the reference electrode 212 and the counter electrode 213.

[0024] FIGS. 4A-4B illustrate detailed illustrations of the current to voltage circuit and the counter-reference servo circuit, respectively, of the analog interface shown in FIG. 3 in accordance with one embodiment of the present invention. Referring to FIG. 4A, the current to voltage circuit 301 (FIG. 3) in one embodiment includes an operational amplifier 402 having a non-inverting input terminal 405, and an inverting input terminal 404. Also shown in the Figure is a resistor 401 operatively coupled to the inverting input terminal 404 of the operational amplifier 402, and an output terminal 406.

[0025] Referring again to FIG. 4A, the work electrode 210 is operatively coupled to the inverting input terminal 404 of the operational amplifier 402, while the guard contact 211 is operatively coupled to the non-inverting input terminal 405 of the operational amplifier 402. It can be further seen that the work voltage source V_w is provided to the non-inverting terminal 405 of the operational amplifier 402. In this manner, in accordance with one embodiment of the present invention, a separate contact, the guard contact 211 is operatively coupled to the analog interface 201 (FIG. 2) of the transmitter 102 (FIG. 2). The guard contact 211 is provided at a substantially equipotential to the work electrode 210 such that any current leakage path to the work electrode 210 (from either the reference electrode 212 or the counter electrode 213, for example) is protected by the guard contact 211 by maintaining the guard contact 211 at substantially the same potential as the work electrode 210.

[0026] Referring now to FIG. 4B, the counter-reference servo unit 302 in accordance with one embodiment includes an operational amplifier 407 having an inverting input terminal 408 and a non-inverting input terminal 409,

as well as an output terminal 410. In one embodiment, the reference electrode 212 is operatively coupled to the inverting input terminal 408, while the counter electrode 213 is operatively coupled to the output terminal 410 of the operational amplifier 407 in the counter-reference servo unit 302. It can also be seen from FIG. 4B that a reference voltage source V_r is provided to the non-inverting input terminal 409 of the operational amplifier 407 in the counter-reference servo unit 302.

[0027] Referring back to FIGS. 3 and 4A-4B, in accordance with one embodiment of the present invention, the current to voltage circuit 301 and the counter-reference servo unit 302 are operatively coupled to the remaining sections of the analog interface 201 of the transmitter 102, and configured to convert the detected glucose level at the sensor unit 101 (FIG. 1) into an analog signal for further processing in the transmitter unit 102. It should also be noted that, in the manner described, the Poise voltage (for example, at a value of 40 mV) may be determined based on the difference between the voltage signal level of the work voltage source V_w at the non-inverting input terminal 405 of the operational amplifier 402 in the current to voltage circuit 301, and the voltage signal level of the reference voltage source V_r at the non-inverting input terminal 409 of the operational amplifier 407 in the counter-reference servo unit 302.

[0028] FIG. 5 illustrates the battery recharging circuit in accordance with one embodiment of the present invention. Referring to the Figure, in one embodiment of the present invention, the analog interface unit 201 of the transmitter unit 102 includes a pair of electrode contacts 510, 520 which are configured to respectively couple to the electrode contacts of the transmitter unit 102 for example, to the electrode contacts for the guard contact 210 and the counter electrode 213 (FIG. 3). Within the scope of the present invention, the guard contact 210 in one embodiment may not be configured as an electrode with respect to the sensor unit 101, but referred to herein as an electrode. The electrode contact 510 which, in one embodiment is coupled to the counter electrode 213 contact of the transmitter unit 102, for example, is coupled in series to a resistor 511 that is in turn, further coupled to a pair of ESD protection diodes 512, 513. Moreover, in one embodiment, the electrode contact 520 which in one embodiment is coupled to the guard contact 210 contact of the transmitter unit 102, is coupled in series to a resistor 521, that is in turn, further coupled to another pair of ESD protection diodes 522, 523.

[0029] In this manner, in one embodiment of the present invention, during the power supply or battery recharging process (for example, when the transmitter unit 102 is docked or positioned in the power supply recharging unit (not shown)), electrode contact 520 is coupled to the recharging unit's ground terminal potential, while the electrode contact 510 is coupled to the positive charging voltage supply. In this manner, as shown in FIG. 5, current I is configured to flow into the electrode contact 510 through resistor 511, and forward bias the ESD pro-

tection diodes 512, and 523, thereby charging the battery 530 of the power supply 207 (FIG. 2) for the transmitter unit 102, and then flow through resistor 521 out to the electrode contact 520 which is held at ground potential as discussed above. Due to symmetry, this process also works when electrode contact 510 is coupled to the recharging unit's ground terminal potential, while the electrode contact 520 is coupled to the positive charging voltage supply such that the ESD protection diodes 513, and 522 become forward biased.

[0030] In the manner described above, in one embodiment of the present invention, the current I may be monitored and the voltage drops across the resistors 511 and 521 and the respective pairs of the ESD protection diodes 512, 513, and 522, 523 may be determined (for example, based on current), so as to control the battery 530 charging voltage level and to ensure that the power supply 207 is properly charged.

[0031] Indeed, in one embodiment of the present invention, a positive charging voltage may be applied to one electrode of the transmitter unit 102 such as the Counter electrode 213 with respect to another electrode such as the guard contact 210, so that current would flow into the electrode contact 510 coupled to the counter electrode 213, through the counter electrode ESD protection resistor 511, and also, through the counter electrode positive clamp diode 512, and through the battery 530 of the power supply 207 thereby charging the battery 530 of the power supply 207. Additionally, the current also flows through the guard contact negative clamp diode 523, and through the guard ESD protection resistor 521, and out the electrode contact 520 coupled to the guard contact 210. In one embodiment, the counter electrode and guard contact ESD protection resistors 511, 521 include nominal resistor values from 50 Ohms to 1KOhm.

[0032] In the embodiment described above, the counter electrode 213 and the guard contact 210 were used for the power supply 207 recharging process because they have lower ESD protection resistors (for example, at 50 Ohms to 1KOhms nominal) as compared to the ESD protection resistors of the work electrode 211 and the reference electrode 212 which may be at 10KOhms nominal. Moreover, the counter electrode 213 and the guard contact 210 have common clamp diodes (For example, having part No. BAV 199) as compared to the low-leakage ESD protection devices that are required for the work electrode 211 and the reference electrode 212 (each of which may use STTRDPAD diodes or alternate ESD protection technology such as the SurgX 0603ESDA). Moreover, they have series resistors (10k nominal) between the clamp diode (ESD protection device) node and the driving circuits.

[0033] Although both the counter electrode 213 and the guard contact 210 signals are outputs, in one embodiment, each has a series resistor (for example, 20KOhms nominal) between the ESD diode clamp node and the associated analog circuitry (not shown) making

it is acceptable to overdrive each of these signals with the charging voltage without causing damage.

[0034] Moreover, it should be noted that the charging voltage to the power supply charging unit should be limited to 3.6 Volts or less to prevent potential damage to the battery 530 and the transmitter unit 102 circuitry during the recharging process. The voltage limit of 3.6 Volts in one embodiment is the voltage limit of the processor 204 of the transmitter unit 102. For example, if the battery 530 is being recharged with a 10mA current and the voltage across the ESD protection resistors 511 and 521 is modeled as 1 Volt each (assuming 100 Ohm valued resistors) and the voltage across the ESD protection diodes 512 and 523 is modeled as 0.7 Volts each (assuming BAV 199 part numbers), then the charging circuit would limit the charging voltage to 7 Volts, which is a sum of the voltages across the ESD protection resistors 511, 521, the voltages across the two ESD protection diodes 512, 523, and the voltage limit of the processor 204.

[0035] Moreover, while the counter electrode 213 and the guard contact 210 are used for the power supply 207 recharging process in the embodiment discussed above, within the scope of the present invention, the work electrode 211 and the reference electrode 212 may be used for the power supply 207 charging process.

[0036] Additionally, within the scope of the present invention, if the comparator used for data input through the AFE was maintained, then the comparator may be configured to toggle when the transmitter unit 102 is docked or coupled to the power supply charging unit, thus effectively, pulling the electrode contact 520 coupled to the guard contact 211 in one embodiment low with respect to the electrode contact 510 coupled in one embodiment to the counter electrode 213, and further, to revert when the transmitter unit 102 is undocked or removed from the power supply charging unit. In this manner, within the scope of the present invention, it is possible to provide a signal representative of an indication that the transmitter unit 102 is in a recharging process, such that the power supply monitoring algorithm for example, in the processor 204 (FIG. 2) may be updated accordingly. For example, the amount of battery 530 life, which decreases with respect to usage time, may be increased with respect to charging time. This allows an accurate estimate of usable battery 530 life so that a new sensor may not be inserted when the system does not have sufficient battery life to support proper operation for the life of a given sensor 101 (FIG. 1). Moreover, this may allow normal transmitter unit 102 operation and RF transmissions to be suspended when the transmitter unit 102 is being charged to prevent RF contention or collision with a second transmitter unit that may be used when the first transmitter unit 102 is charging.

[0037] In the manner described above, in accordance with one embodiment of the present invention, to maintain the smallest possible size and cost, is a method of recharging the battery or power supply 207 of the transmitter unit 102 through the ESD protection circuitry on

two of the four electrodes 210-213. Moreover, in the manner described above, in one embodiment of the present invention, the risk of having a pair of unprotected battery contacts exposed to the patient and the environment is eliminated.

[0038] Indeed, as discussed above, in accordance with the various embodiments of the present invention, when the data monitoring and management system 100 (and in particular, the transmitter unit 102) is not connected to a patient, it can be connected to a battery charging system. This battery charger would hold one of the two electrodes used for charging the battery at the chargers ground potential. The second of the two electrodes used for charging the battery would then be brought to a potential to forward bias the ESD protection diodes causing a current to flow into one electrode, through any series resistance, through an ESD protection diode to the positive battery contact, through the battery - thus charging the battery, out the negative battery contact through another ESD protection diode, through any series resistance, and out the second electrode. By monitoring the current and calculating the voltage drops across any series resistance elements and the ESD protection diodes, the battery voltage can be controlled and proper charging achieved.

[0039] FIG. 6 illustrates a portion of the battery recharging circuit for battery recharging through ESD protection circuitry in accordance with another embodiment of the present invention. Referring to the Figure, a battery recharging unit 610 (such as, for example, a recharging docking station) is provided with a pair of diodes 611, 612 coupled to a resistor 613 as shown in the Figure such that a current I is configured to flow from electrode contact 510, into the transmitter unit 102, and back out through the electrode contact 520, thus creating a recharging current path through the rechargeable battery 530 (for example, FIG. 5) in the transmitter unit 102 power supply 207.

[0040] While the voltage level at the electrode contact 510 (at terminal Vout shown in FIG. 5) may be driven directly, the recharging unit needs to have knowledge of the recharging voltage at the battery, and thus the recharging current through the various ESD components such as the diodes and series resistors as described above. Moreover, most batteries require recharging based on a voltage-current profile over time. Indeed, many batteries require different voltage-current profiles for various stages of the charging process (i.e. one profile for a "fast-charge" portion up to 80% recharge and another profile for the remaining recharge portion, for example). As a result, the charging voltage is often driven through a shunt resistor 613, that is, at the drive node Vr3, with feedback to indicate the charging current and voltage (Vr3 minus Vout and Vout respectively).

[0041] In one embodiment, the battery recharging process through ESD protection circuitry may include driving node Vdrive and determining the feedback at the node Vdrive, node Vr3 and node Vout, to calculate the

current into and voltage across the rechargeable battery 530, where the diode 611 and the resistor 613 are selected to match the component values of the ESD protection circuitry for the transmitter unit 102 being recharged. Thus the voltage across the diode 612 and the resistor 613 ($V_{drive} - V_{out}$) matches the voltage across the resistor 511 (FIG. 5) and the diode 512 (FIG. 5) pair and the voltage across the resistor 521 (FIG. 5) and the diode 523 (FIG. 5) pair giving the battery 530 voltage as $V_{out} - 2 * (V_{drive} - V_{out})$ or $3V_{out} - 2V_{drive}$.

[0042] One advantage of this approach is that there is no need to model the voltage drop across the ESD protection diodes, which are not linear with respect to current, as they match the voltage drop across the diode 612, where the diode 611 is inactive just as, for example the diode 513 (FIG. 5) and the diode 522 are inactive (there is similar component package heating as all components are used in a similar fashion).

[0043] For example, if the transmitter unit 102 being recharged uses BAV 199 ESD protection diodes and 100 Ohm series resistors as described above, then the diode 611 is a BAV 199 diode and the resistor 613 is 100 Ohms (the precision of which is selected as is appropriate) such that the current $I = \frac{V_{r3} - V_{out}}{R3}$ (resistor 613), which is equal to $\frac{V_{r3} - V_{out}}{100}$. The voltage at V_{drive} is then driven using analog, digital (digital logic such as a microprocessor and a D/A converter) or some combination of mixed signal techniques (analog and digital) to maintain the preferred voltage-current battery recharging profile over time. Moreover, this technique allows the recharging circuitry to be larger and more complex while maintaining the small size and low cost of the unit being recharged.

[0044] FIGS. 7A-7B illustrates inductive battery recharging in accordance with alternate embodiments of the present invention. Referring to FIG. 7A, in one embodiment of the present invention, during the power supply or battery recharging process (for example, when the transmitter unit 102 is docked or positioned in the power supply recharging unit 760), power source 710, such as a wall plug or an external battery, is coupled to a power driver 720 of the power supply recharging unit 760. As shown in the Figure, there is also provided a power circuit 730 in the power supply 207 of the transmitter unit 102 which, together with the power driver 720 comprise a transformer. As can be further seen from FIG. 7A, the power circuit 730 in the power supply 207 of the transmitter unit 102 in one embodiment may be further coupled to the power supply source 740 which is configured to supply power to the transmitter unit 102 when the transmitter is in normal operation, and further, to the rechargeable battery 750.

[0045] In this manner, in one embodiment of the present invention, the power circuit 730 of the power supply 207 in the transmitter unit 102 may be configured to recharge the battery 750 based on a predetermined and/or desired voltage-current recharging profiles whenever power is applied via the power source 710 and power driver 720.

[0046] Referring to FIG. 7B, an alternate embodiment of the inductive power supply recharging schematic is shown, where, there is also provided a separate connection to the rechargeable battery 750 coupled to the power circuit 730, and which, in one embodiment is configured to supply power to the transmitter unit 102 power supply 207 via the power supply source 740, or alternatively, be recharged by the power circuit 730 via the power source 710 when coupled thereto. When recharging, the power supply source 740 may be set to 0 Volts to disable system operation, or alternatively, may be a valid operating voltage provided by the power circuit 730. One advantage of this approach is that the power circuit 730 need not account for power being consumed by the supply source 740 when recharging the battery 750 according to the predetermined and/or desired voltage-current profiles.

[0047] In the manner described above, in accordance with one embodiment of the present invention, inductive power charging is provided using a transformer and receiving power from an external power source during the power supply or battery recharging process (for example, when the transmitter unit 102 is docked or positioned in the power supply recharging unit). Moreover, a rechargeable battery may be provided in the transmitter unit to provide power when the external power source is disconnected. Similar to the approach shown in FIG. 5 above, in one aspect of the present invention, the power circuit 730 may provide a signal representative of an indication that the transmitter unit 102 is in a recharging process, such that the power supply monitoring algorithm for example, in the processor 204 (FIG. 2) may be updated accordingly.

[0048] In this manner, within the scope of the present invention, there is provided an apparatus for recharging power in a data communication device including a plurality of contacts, a power source operatively coupled to the plurality of contacts, and a rechargeable battery operatively coupled to the plurality of contacts, where the rechargeable battery is configured to receive a predetermined signal from the power source, and further, where the rechargeable battery is configured to recharge based on the predetermined signal from the power source.

[0049] The plurality of contacts may include a guard contact and a counter electrode, and the rechargeable battery and the plurality of contacts may be provided in a data communication device, wherein the rechargeable battery is configured to provide power to the data communication device.

[0050] The data communication device in one embodiment may include a data transmitter, and the data transmitter may be configured to transmit measured glucose data. In one embodiment, the data communication device may be configured for either a uni-directional or bi-directional wireless data communication. Further, in one embodiment, the wireless data communication may include one or more of the following data communication protocols: rf communication, infrared communication, Bluetooth data communication; and 802.11x communication

protocol.

[0051] In a further aspect, the transmitter may be configured to receive the measured glucose data from a sensor, where the sensor may include one of a subcutaneous sensor and a transcutaneous sensor, configured to detect an analyte level, which in one embodiment includes glucose level.

[0052] An apparatus including a rechargeable power in a glucose monitoring system in a further embodiment of the present invention includes a sensor configured to detect one or more glucose level of a patient, a transmitter unit configured to receive the one or more detected glucose levels, and to transmit one or more data corresponding to the detected one or more glucose levels, and a receiver unit configured to receive the transmitted one or more measured glucose data, where the transmitter unit includes a rechargeable battery, where the sensor includes a plurality of sensor contacts, each of the plurality of sensor contacts coupled to the transmitter unit, and further, where a pair of the plurality of sensor contacts coupled to the transmitter unit is configured to receive a predetermined power signal to charge the rechargeable batter of the transmitter unit.

[0053] In one embodiment, the pair of plurality of sensor contacts configured to receive a predetermined power signal may include a guard contact and a counter electrode, and further, where the predetermined power signal may include a current signal from a power source.

[0054] A method for recharging power in a data communication device in a further embodiment of the present invention includes the steps of providing a plurality of contacts, operatively coupling a power source to the plurality of contacts, and operatively coupling a rechargeable battery to the plurality of contacts, the rechargeable battery configured to receive a predetermined signal from the power source, where the rechargeable battery is configured to recharge based on the predetermined signal from the power source.

[0055] The method in a further embodiment may include the step of providing the rechargeable battery and the plurality of contacts in a data communication device, where the rechargeable battery is configured to provide power to the data communication device.

[0056] Various other modifications and alterations in the structure and method of operation of this invention will be apparent to those skilled in the art without departing from the scope and spirit of the invention. Although the invention has been described in connection with specific preferred embodiments, it should be understood that the invention as claimed should not be unduly limited to such specific embodiments. It is intended that the following claims define the scope of the present invention and that structures and methods within the scope of these claims and their equivalents be covered thereby.

Claims

1. An apparatus for recharging a rechargeable battery in a data communication device which includes a plurality of contacts (510, 520), a power source operatively coupled to the plurality of contacts and a rechargeable battery (530) operatively coupled to the plurality of contacts, the rechargeable battery being configured to receive and recharge in response to a power signal from the power source, the apparatus including an analyte sensor (101) including a plurality of electrodes (210 - 213) which can be coupled through an analogue interface circuit (201) to a data transmitter (206), **characterised in that** the contacts (510, 520) are configured to couple to two of the said electrodes and the contacts are connected to provide a recharging current for the rechargeable battery by way of an electrostatic discharge protection circuit in the analogue interface circuit (201).
2. Apparatus according to claim 1 in which the electrostatic discharge protection circuit comprises for each contact a series resistor (511, 521) and a pair of electrostatic discharge protection diodes (521, 513; 522, 523) arranged so that charging current flows from one of the contacts (510) through one of the diodes in one pair, the battery and a diode in the other pair to the other contact (520).
3. Apparatus according to claim 1 or 2 in which the electrodes are a guard electrode (211) and a counter electrode (213).
4. Apparatus according to claim 1 or 2 in which the electrodes are a work electrode (210) and a reference electrode (212).
5. A method of recharging a rechargeable battery in a data communication device which includes a plurality of contacts (510, 520), a power source operatively coupled to the plurality of contacts and a rechargeable battery (530) operatively coupled to the plurality of contacts, the rechargeable battery being configured to receive and recharge in response to a power signal from the power source, the apparatus including an analyte sensor (101) including a plurality of electrodes (210 - 213) which can be coupled through an analogue interface circuit (201) to a data transmitter (206), **characterised by** coupling the contacts (510, 520) to two of the said electrodes when the sensor is connected to provide signals for the transmitter, providing electrostatic discharge protection by means of an electrostatic protection circuit in the analogue interface circuit, and coupled to said contacts, providing a recharging current for the rechargeable battery by way of an electrostatic discharge protection circuit in the analogue interface circuit (201).

6. A method according to claim 5, in which the two electrodes are a guard electrode (211) and a counter electrode (213).
7. A method according to claim 5 or 6, in which the data transmitter (206) is configured to transmit measured glucose data.
8. A method according to any of claims 5 to 7, in which the sensor (101) is a subcutaneous sensor or a transcutaneous sensor, configured to detect an analyte level.
9. A method according to any of claims 5 to 8, further comprising monitoring the recharging current
10. A method according to any of claims 5 to 9, further comprising providing a signal representative of an indication of the charging of the rechargeable battery.
11. A method according to any of claims 5 to 10, in which the recharging of the battery is performed when the transmitter is not configured for the transmission of data.

Patentansprüche

1. Vorrichtung zum Wiederaufladen einer wiederaufladbaren Batterie in einer Datenübertragungsvorrichtung, die eine Vielzahl von Kontakten (510, 520), eine Leistungsquelle, die wirksam mit der Vielzahl von Kontakten gekoppelt ist, und eine wiederaufladbare Batterie (530), die wirksam mit der Vielzahl von Kontakten gekoppelt ist, umfasst, wobei die wiederaufladbare Batterie zum Empfangen und Wiederaufladen in Reaktion auf ein Leistungssignal von der Leistungsquelle ausgelegt ist, wobei die Vorrichtung einen Analytensensor (101) mit einer Vielzahl von Elektroden (210 - 213) umfasst, die durch eine analoge Schnittstellenschaltung (201) mit einem Datensender (206) gekoppelt werden können, **dadurch gekennzeichnet, dass** die Kontakte (510, 520) dazu ausgelegt sind, mit zwei der Elektroden gekoppelt zu werden, und die Kontakte zum Liefern eines Wiederaufladestroms für die wiederaufladbare Batterie über eine in der analogen Schnittstellenschaltung (201) vorgesehene Schaltung zum Schutz vor elektrostatischer Entladung verbunden werden.
2. Vorrichtung nach Anspruch 1, wobei die Schaltung zum Schutz vor elektrostatischer Entladung für jeden Kontakt einen Reihenwiderstand (511, 521) und ein Paar von Dioden (512, 513; 522, 523) zum Schutz vor elektrostatischer Entladung umfasst, die so angeordnet sind, dass ein Aufladestrom von einem der Kontakte (510) durch eine der Dioden in einem Paar, die Batterie und eine Diode im anderen Paar zum anderen Kontakt (520) fließt.
3. Vorrichtung nach Anspruch 1 oder 2, wobei die Elektroden eine Schutzelektrode (211) und eine Gegenelektrode (213) sind.
4. Vorrichtung nach Anspruch 1 oder 2, wobei die Elektroden eine Arbeitselektrode (210) und eine Referenzelektrode (212) sind.
5. Verfahren zum Wiederaufladen einer wiederaufladbaren Batterie in einer Datenübertragungsvorrichtung, die eine Vielzahl von Kontakten (510, 520), eine Leistungsquelle, die wirksam mit der Vielzahl von Kontakten gekoppelt ist, und eine wiederaufladbare Batterie (530), die wirksam mit der Vielzahl von Kontakten gekoppelt ist, umfasst, wobei die wiederaufladbare Batterie zum Empfangen und Wiederaufladen in Reaktion auf ein Leistungssignal von der Leistungsquelle ausgelegt ist, wobei die Vorrichtung einen Analytensensor (101) mit einer Vielzahl von Elektroden (210 - 213) umfasst, die durch eine analoge Schnittstellenschaltung (201) mit einem Datensender (206) gekoppelt werden können, **gekennzeichnet durch** Koppeln der Kontakte (510, 520) mit zwei der Elektroden, wenn der Sensor verbunden wird, um Signale für den Sender zu liefern, Vorsehen eines Schutzes vor elektrostatischer Entladung mittels einer mit den Kontakten gekoppelten Schaltung zum elektrostatischen Schutz, die in der analogen Schnittstellenschaltung vorgesehen ist, Liefern eines Wiederaufladestroms für die wiederaufladbare Batterie über eine in der analogen Schnittstellenschaltung (201) vorgesehene Schaltung zum Schutz vor elektrostatischer Entladung).
6. Verfahren nach Anspruch 5, wobei die zwei Elektroden eine Schutzelektrode (211) und eine Gegenelektrode (213) sind.
7. Verfahren nach Anspruch 5 oder 6, wobei der Datensender (206) dazu ausgelegt ist, Messdaten von Glucose zu übertragen.
8. Verfahren nach einem der Ansprüche 5 bis 7, wobei der Sensor (101) ein subkutaner Sensor oder ein transkutaner Sensor ist, der dazu ausgelegt ist, einen Analytenspiegel zu erfassen.
9. Verfahren nach einem der Ansprüche 5 bis 8, das ferner das Überwachen des Wiederaufladestroms umfasst.
10. Verfahren nach einem der Ansprüche 5 bis 9, das ferner das Liefern eines Signals, das eine Anzeige der Aufladung der wiederaufladbaren Batterie darstellt, umfasst.

11. Verfahren nach einem der Ansprüche 5 bis 10, wobei das Wiederaufladen der Batterie durchgeführt wird, wenn der Sender nicht für die Übertragung von Daten konfiguriert ist.

Revendications

1. Appareil pour recharger une batterie rechargeable dans un dispositif de communication de données qui comprend une pluralité de contacts (510, 520), une source d'alimentation couplée de manière fonctionnelle à la pluralité de contacts et une batterie rechargeable (530) couplée de manière fonctionnelle à la pluralité de contacts, la batterie rechargeable étant configurée pour recevoir et recharger en réponse à un signal d'alimentation provenant de la source d'alimentation, l'appareil comprenant un capteur d'analytes (101) comprenant une pluralité d'électrodes (210 à 213) qui peuvent être couplées grâce à un circuit d'interface analogique (201) à un transmetteur de données (206), **caractérisé en ce que** les contacts (510, 520) sont configurés pour être couplés à deux desdites électrodes et les contacts sont reliés pour fournir un courant de recharge pour la batterie rechargeable au moyen d'un circuit de protection de décharge électrostatique dans le circuit d'interface analogique (201).
2. Appareil selon la revendication 1, dans lequel le circuit de protection de décharge électrostatique comprend pour chaque contact une résistance en série (511, 521) et une paire de diodes de protection de décharge électrostatique (521, 513 ; 522, 523) agencées de sorte qu'un courant de charge circule à partir de l'un des contacts (510) à travers l'une des diodes dans une paire, la batterie et une diode dans l'autre paire à l'autre contact (520).
3. Appareil selon la revendication 1 ou 2, dans lequel les électrodes sont une électrode de garde (211) et une contre électrode (213).
4. Appareil selon la revendication 1 ou 2, dans lequel les électrodes sont une électrode de travail (210) et une électrode de référence (212).
5. Procédé de recharge d'une batterie rechargeable dans un dispositif de communication de données qui comprend une pluralité de contacts (510, 520), une source d'alimentation couplée de manière fonctionnelle à la pluralité de contacts et une batterie rechargeable (530) couplée de manière fonctionnelle à la pluralité de contacts, la batterie rechargeable étant configurée pour recevoir et recharger en réponse à un signal d'alimentation provenant de la source d'alimentation, l'appareil comprenant un capteur d'analytes (101) comprenant une pluralité d'électrodes

- (210 à 213) qui peuvent être couplées par un circuit d'interface analogique (201) à un transmetteur de données (206), **caractérisé par** le couplage des contacts (510, 520) à deux desdites électrodes quand le capteur est relié pour fournir des signaux au transmetteur, la fourniture d'une protection de décharge électrostatique au moyen d'un circuit de protection électrostatique dans le circuit d'interface analogique ; et couplé auxdits contacts, la fourniture d'un courant de recharge pour la batterie rechargeable au moyen d'un circuit de protection de décharge électrostatique dans le circuit d'interface analogique (201).
- 5
6. Procédé selon la revendication 5, dans lequel les deux électrodes sont une électrode de garde (211) et une contre électrode (213).
7. Procédé selon la revendication 5 ou 6, dans lequel le transmetteur de données (206) est configuré pour transmettre des données concernant le glucose.
8. Procédé selon l'une quelconque des revendications 5 à 7, dans lequel le capteur (101) est un capteur sous-cutané ou un capteur transcutané, configuré pour détecter un niveau d'analytes.
9. Procédé selon l'une quelconque des revendications 5 à 8, comprenant en outre la surveillance du courant de recharge.
10. Procédé selon l'une quelconque des revendications 5 à 9, comprenant en outre la fourniture d'un signal représentatif d'une indication de la charge de la batterie rechargeable.
11. Procédé selon l'une quelconque des revendications 5 à 10, dans lequel la recharge de la batterie est réalisée quand le transmetteur n'est pas configuré pour la transmission de données.
- 10

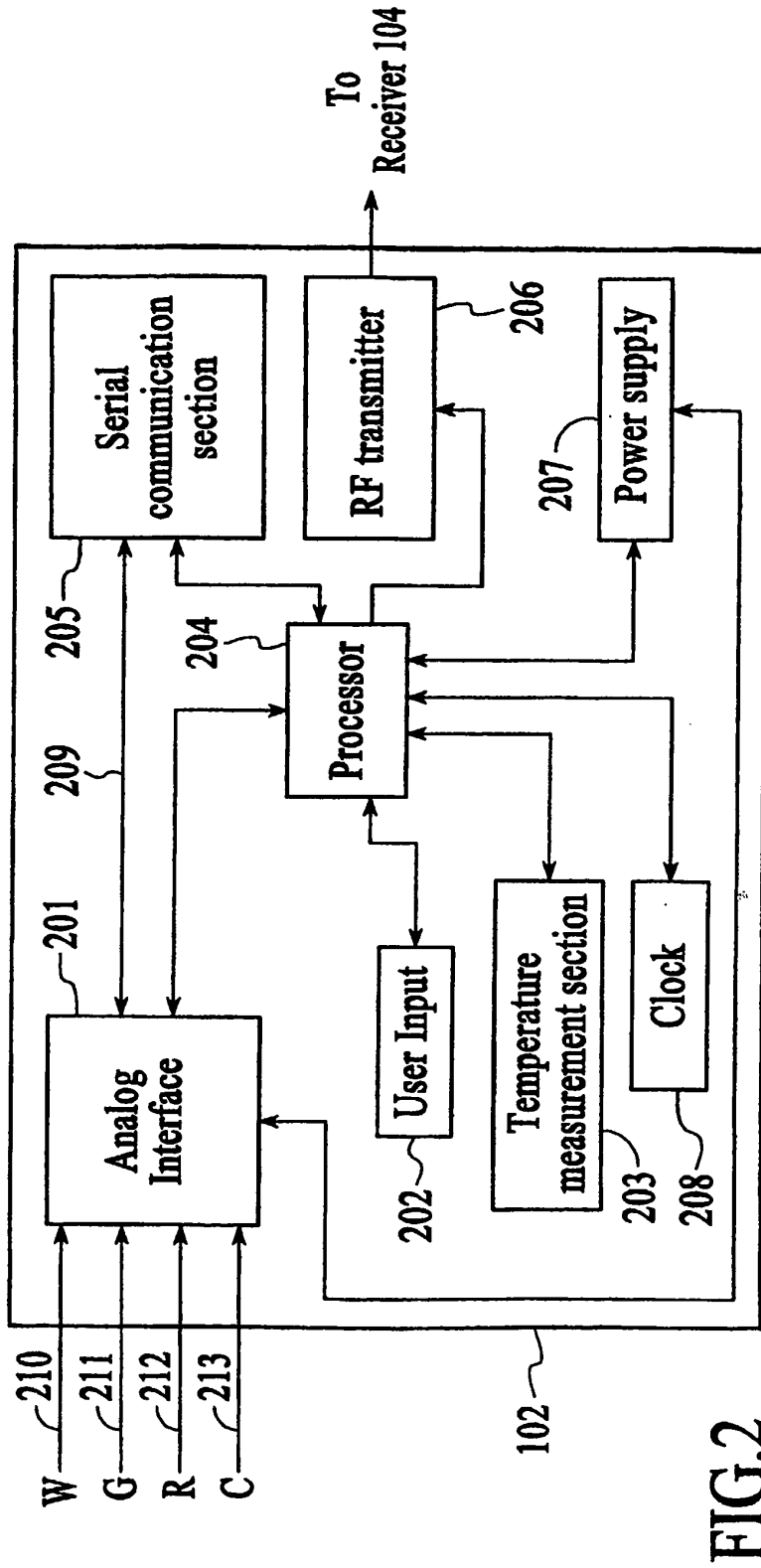
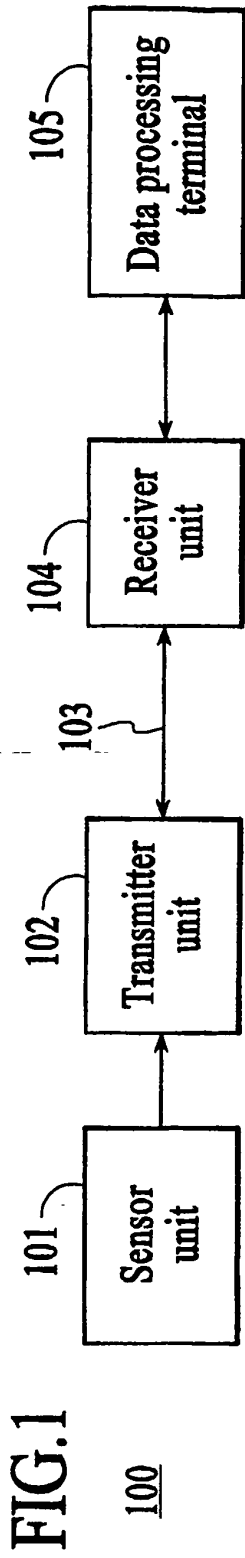

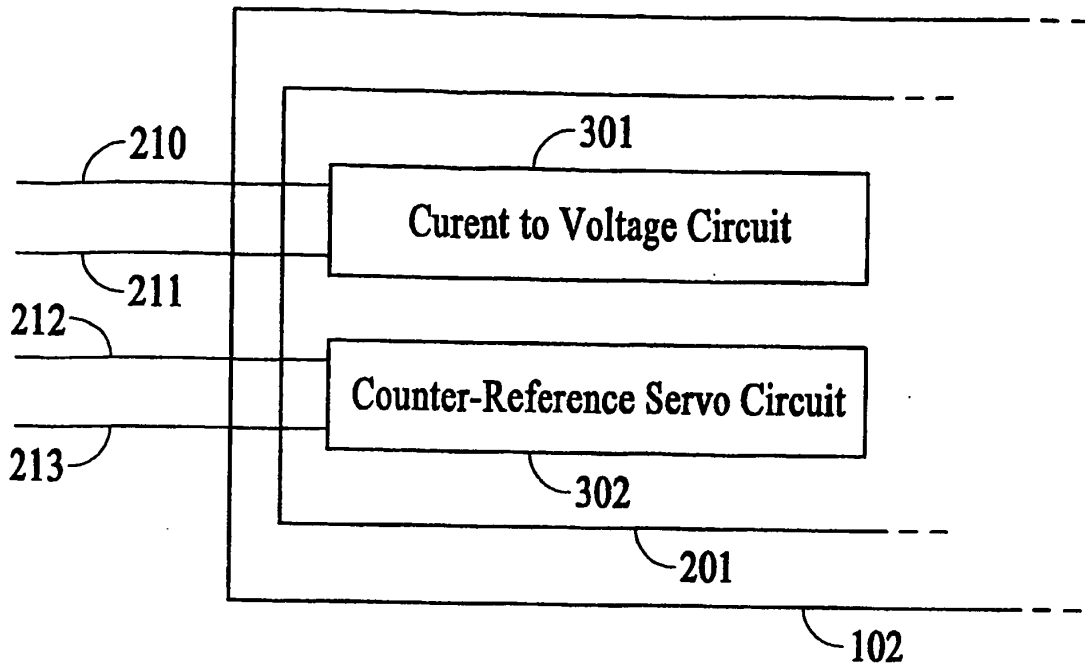

FIG.3

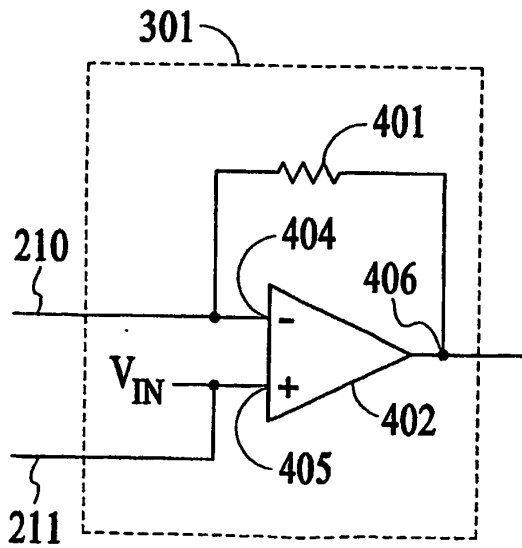

FIG.4A

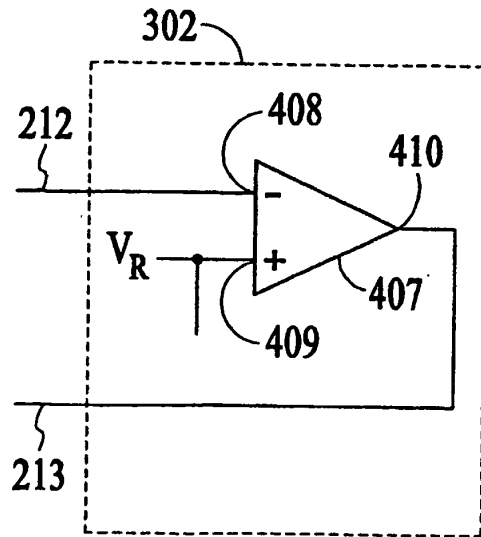
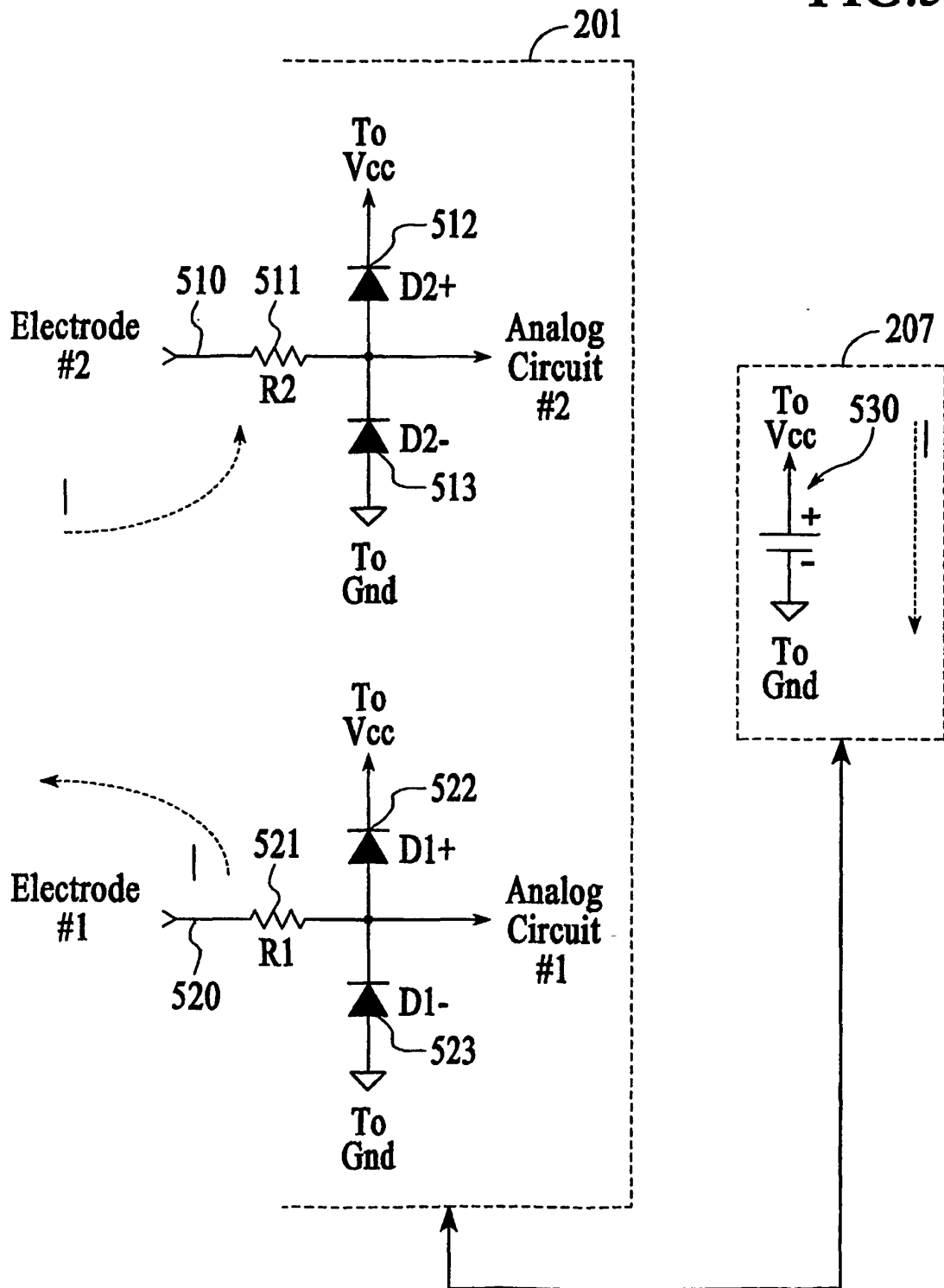

FIG.4B

FIG.5



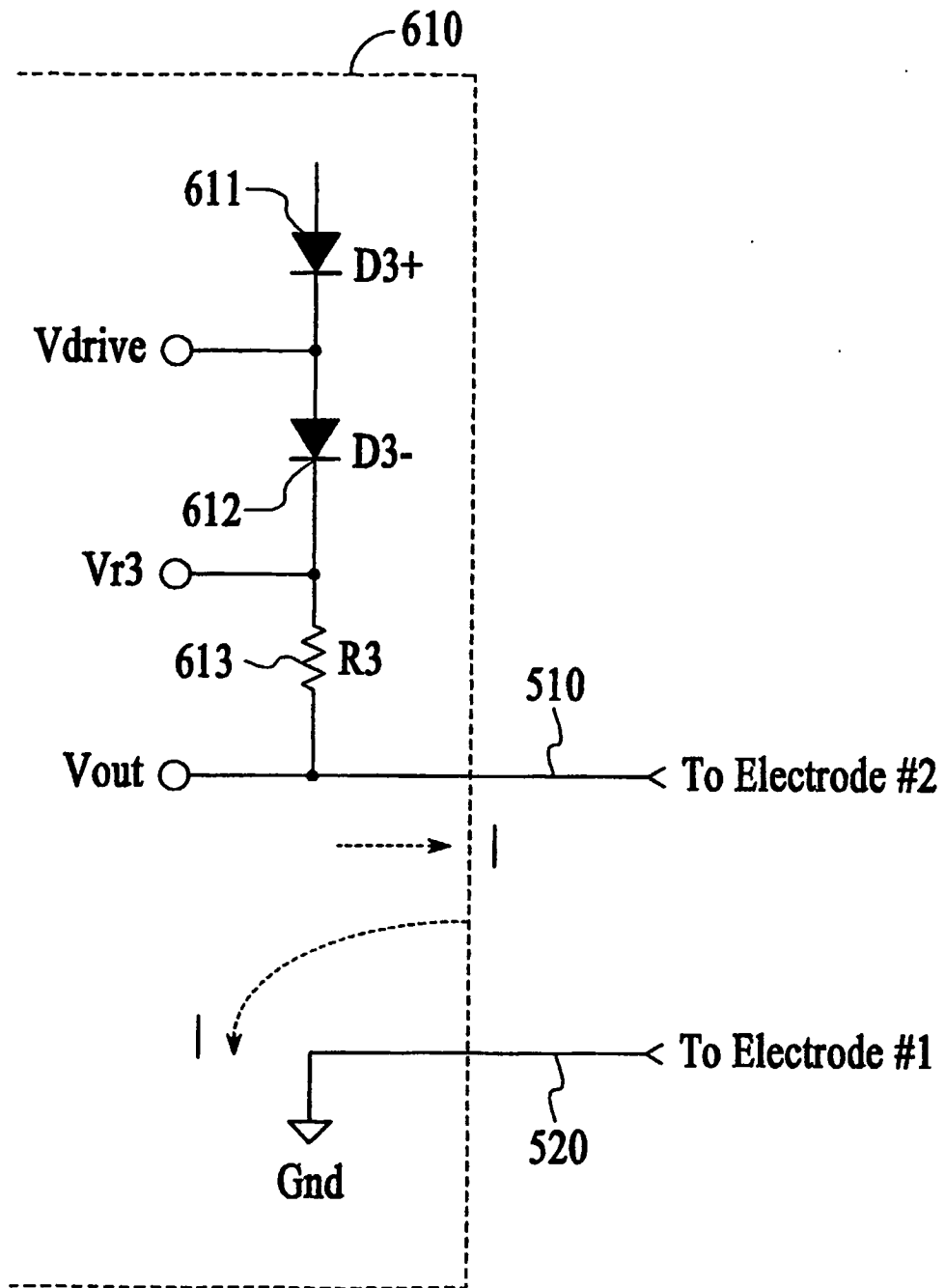

FIG.6

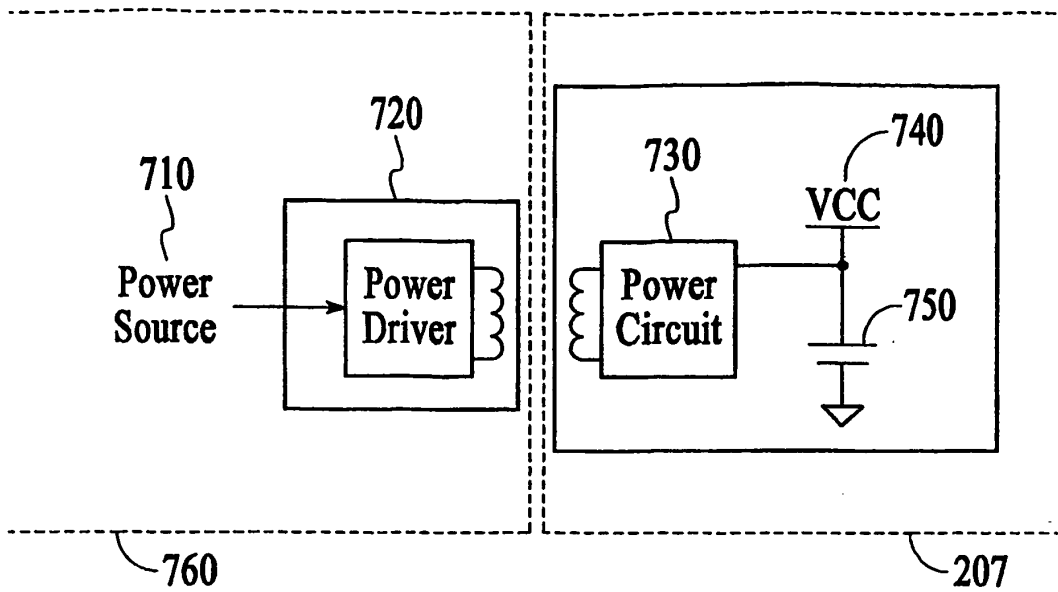

FIG. 7A

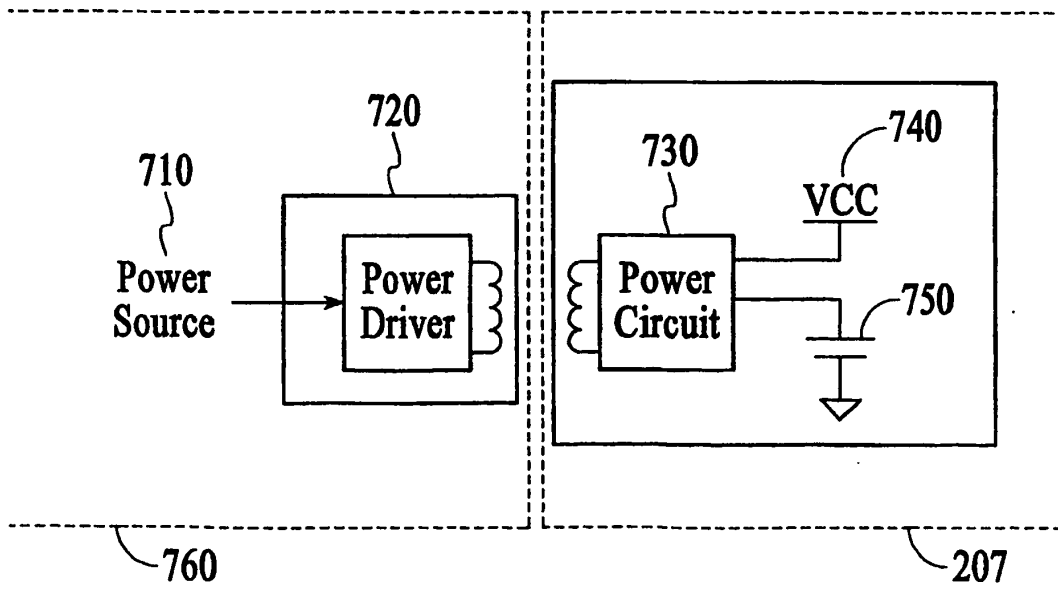

FIG. 7B

REFERENCES CITED IN THE DESCRIPTION

This list of references cited by the applicant is for the reader's convenience only. It does not form part of the European patent document. Even though great care has been taken in compiling the references, errors or omissions cannot be excluded and the EPO disclaims all liability in this regard.

Patent documents cited in the description

- US 0185452 B1 [0005]
- US 6175752 B [0022]
- US 10745878 B [0022]

专利名称(译)	用于在数据监视和管理系统中提供可再充电电力的方法和装置		
公开(公告)号	EP1890597B1	公开(公告)日	2012-02-22
申请号	EP2006760592	申请日	2006-05-31
[标]申请(专利权)人(译)	雅培糖尿病护理公司		
申请(专利权)人(译)	雅培糖尿病, INC.		
当前申请(专利权)人(译)	雅培糖尿病INC.		
[标]发明人	REGGIARDO CHRISTOPHER V		
发明人	REGGIARDO, CHRISTOPHER, V.		
IPC分类号	A61B5/05 A61B5/00		
CPC分类号	H02J7/0045 A61B5/0002 A61B5/14532 A61B2560/0214 A61B2560/0252		
优先权	11/145048 2005-06-03 US		
其他公开文献	EP1890597A4 EP1890597A2		
外部链接	Espacenet		

摘要(译)

用于对诸如可充电电池的电源单元进行充电的方法和装置，用于使用包括保护触点和电极的现有电极触点的ESD保护电路的数据监视和管理系统，从而降低系统成本，复杂性和任何未受保护的电池触点暴露于潜在的污染。

