

(19)



(11)

EP 1 876 945 B1

(12)

EUROPEAN PATENT SPECIFICATION

(45) Date of publication and mention of the grant of the patent:
05.12.2012 Bulletin 2012/49

(51) Int Cl.:
A61B 5/00 (2006.01)

(21) Application number: **06737020.5**

(86) International application number:
PCT/US2006/007790

(22) Date of filing: **06.03.2006**

(87) International publication number:
WO 2006/096582 (14.09.2006 Gazette 2006/37)

(54) **COMMUNICATING WITH AN IMPLANTED WIRELESS SENSOR**

KOMMUNIKATION MIT EINEM IMPLANTIERTEM DRAHTLOSEN SENSOR

COMMUNICATION AVEC UN CAPTEUR SANS FIL IMPLANTE

(84) Designated Contracting States:
AT BE BG CH CY CZ DE DK EE ES FI FR GB GR HU IE IS IT LI LT LU LV MC NL PL PT RO SE SI SK TR

- **MILLER, Donald**
Roswell, Georgia 30075 (US)
- **ELLIS, Michael**
Alpharetta, Georgia 30005 (US)

(30) Priority: **04.03.2005 US 658680 P**
13.04.2005 US 105294

(74) Representative: **Boff, James Charles et al**
Phillips & Leigh
5 Pemberton Row
London EC4A 3BA (GB)

(43) Date of publication of application:
16.01.2008 Bulletin 2008/03

(73) Proprietor: **CardioMems, Inc.**
Atlanta, GA 30313 (US)

- (56) References cited:
- | | |
|----------------------------|----------------------------|
| EP-A2- 0 450 653 | WO-A-2005/027998 |
| WO-A-2006/049796 | AU-B2- 701 577 |
| DE-A1- 3 330 519 | DE-A1- 19 510 452 |
| GB-A- 2 098 430 | US-A- 4 160 971 |
| US-A- 4 531 526 | US-A- 4 593 703 |
| US-A1- 2003 139 677 | US-A1- 2005 046 558 |

- (72) Inventors:
- **ALLEN, Mark**
Atlanta, Georgia 30328 (US)
 - **KROH, Jason**
Villa Rica, Georgia 30180 (US)

EP 1 876 945 B1

Note: Within nine months of the publication of the mention of the grant of the European patent in the European Patent Bulletin, any person may give notice to the European Patent Office of opposition to that patent, in accordance with the Implementing Regulations. Notice of opposition shall not be deemed to have been filed until the opposition fee has been paid. (Art. 99(1) European Patent Convention).

Description

TECHNICAL FIELD

[0001] The present invention is directed in general to communicating with a wireless sensor, and in particular to communicating with a wireless sensor implanted within the body to measure a physical condition.

BACKGROUND

[0002] Wireless sensors can be implanted within the body and used to monitor physical conditions, such as pressure or temperature. For example, U.S. Patent No. 6,111,520, U.S. Patent No. 6,855,115 and U.S. Publication No. 2003/0136417 all describe wireless sensors that can be implanted within the body. These sensors can be used to monitor physical conditions within the heart or an abdominal aneurysm. An abdominal aortic aneurysm (AAA) is a dilatation and weakening of the abdominal aorta that can lead to aortic rupture and sudden death. In the case of a repaired abdominal aneurysm, a sensor can be used to monitor pressure within the aneurysm sac to determine whether the intervention is leaking. The standard treatment for AAAs employs the use of stent-grafts that are implanted via endovascular techniques. However, a significant problem that has emerged with these stent-grafts for AAAs is acute and late leaks of blood into the aneurysms sac. Currently, following stent-graft implantation, patients are subjected to periodic evaluation via abdominal CT (Computed Tomography) with IV contrast to identify the potential presence of stent-graft leaks. This is an expensive, risky procedure that lacks appropriate sensitivity to detect small leaks.

[0003] Typically, the sensors utilize an inductive-capacitive ("LC") resonant circuit with a variable capacitor. The capacitance of the circuit varies with the pressure of the environment in which the sensor is located and thus, the resonant frequency of the circuit varies as the pressure varies. Thus, the resonant frequency of the circuit can be used to calculate pressure.

[0004] Ideally, the resonant frequency is determined using a non-invasive procedure. Several examples of procedures for determining the resonant frequency of an implanted sensor are discussed in U.S. Patent No. 6,111,520. Some of the procedures described in the patent require the transmission of a signal having multiple frequencies. A drawback of using a transmission signal having multiple frequencies is that the energy in the frequency bands outside the resonant frequency is wasted. This excess energy requires more power which results in an increase in cost, size and thermal requirements, as well as an increase in electromagnetic interference with other signals. Thus, there is a need for an optimized method that is more energy efficient and requires less power.

[0005] There are unique requirements for communicating with an implanted sensor. For example, the system

must operate in a low power environment and must be capable of handling a signal from the sensor with certain characteristics. For example, the signal from the sensor is relatively weak and must be detected quickly because the signal dissipates quickly. These requirements also impact the way that common problems are handled by the system. For example, the problems of switching transients and false locking need to be handled in a manner that accommodates the sensor signal characteristics. Thus, there is a need for a method for communicating with a wireless sensor that operates in a low power environment and that efficiently determines the resonant frequency of the sensor.

[0006] The resonant frequency of the sensor is a measured parameter that is correlated with the physical parameter of interest. To be clinically useful there must be means to ensure that variations in measurement environment do not affect the accuracy of the sensor. Thus, there is a need for a system and method for communicating with a wireless sensor that considers variations in the measurement environment.

SUMMARY OF THE INVENTION

[0007] The invention is defined in the appended set of claims.

[0008] The primary goal of aneurysm treatment is to depressurize the sac and to prevent rupture. Endoleaks, whether occurring intraoperatively or postoperatively, can allow the aneurysmal sac to remain pressurized and therefore increase the chance of aneurysm rupture. The current imaging modalities angiography and CT scan are not always sensitive enough to detect endoleaks or stent graft failure. Intrasc pressure measurements provide a direct assessment of sac exclusion from circulation and may therefore offer intraoperative and post operative surveillance advantages that indirect imaging studies do not.

[0009] In one application of the present invention an AAA pressure sensor is placed into the aneurysm sac at the time of stent-graft insertion. The pressure readings are read out by the physician by holding an electronic instrument, which allows an immediate assessment of the success of the stent-graft at time of the procedure and outpatient follow-up visits, by reading the resonant frequency of the wireless sensor and correlating the frequency reading to pressure.

[0010] The present invention meets the needs described above by providing a system and method for communicating with a wireless sensor to determine the resonant frequency of the sensor. The system energizes the sensor with a low duty cycle, gated burst of RF energy having a predetermined frequency or set of frequencies and a predetermined amplitude. The energizing signal is coupled to the sensor via a magnetic loop. The sensor may be an inductive-capacitive ("LC") resonant circuit with a variable capacitor that is implanted within the body and used to measure physical parameters, such as pressure or temperature. The energizing signal induces a cur-

rent in the sensor which is maximized when the energizing frequency is the same as the resonant frequency of the sensor. The system receives the ring down response of the sensor via magnetic coupling and determines the resonant frequency of the sensor, which is used to calculate the measured physical parameter.

[0011] A pair of phase locked loops ("PLLs") is used to adjust the phase and the frequency of the energizing signal until its frequency locks to the resonant frequency of the sensor. One PLL samples during the calibration cycle and the other PLL samples during the measurement cycle. These cycles alternate every 10 microseconds synchronized with the pulse repetition period. The calibration cycle adjusts the phase of the energizing signal to a fixed reference phase to compensate for system delay or varying environmental conditions. The environmental conditions that can affect the accuracy of the sensor reading include, but are not limited to, proximity of reflecting or magnetically absorptive objects, variation of reflecting objects located within transmission distance, variation of temperature or humidity which can change parameters of internal components, and aging of internal components.

[0012] One of the PLLs is used to adjust the phase of the energizing signal and is referred to herein as the fast PLL. The other PLL is used to adjust the frequency of the energizing signal and is referred to herein as the slow PLL. During the time that the energizing signal is active, a portion of the signal enters the receiver and is referred to herein as a calibration signal. The calibration signal is processed and sampled to determine the phase difference between its phase and the phase of a local oscillator (referred to herein as the local oscillator 2). The cycle in which the calibration signal is sampled is referred to as the calibration cycle. The system adjusts the phase of the energizing signal to drive the phase difference to zero or another reference phase.

[0013] During the measurement cycle, the signal coupled from the sensor (referred to herein as the coupled signal or the sensor signal) is processed and sampled to determine the phase difference between the coupled signal and the energizing signal. The system then adjusts the frequency of the energizing signal to drive the phase difference to zero or other reference phase. Once the slow PLL is locked, the frequency of the energizing signal is deemed to match the resonant frequency of the sensor. The operation of the slow PLL is qualified based on signal strength so that the slow PLL does not lock unless the strength of the coupled signal meets a predetermined signal strength threshold.

[0014] The signal coupled from the sensor is processed using continuous signal processing techniques instead of sample and hold techniques. Continuous signal processing techniques avoid some of the drawbacks of sample and hold techniques. For instance, the timing of the sample point is a trade-off. The sample needs to be taken after the filtering and the switching transients settle out, which tends to delay the sample point, but before

the sensor signal dissipates, which tends to advance the sample point since the sensor signal dissipates very quickly. Delaying or advancing the sampled point too much affects accuracy. A DC offset or other disturbance that affects the sampled point may provide an inaccurate result. Sampling can also affect efficiency since only a portion of the signal is used.

[0015] To implement continuous signal processing, a pair of parallel IF paths are provided, one for the calibration cycle and one for the measurement cycle. Each of the IF paths includes a narrow bandpass filter. The outputs of the IF paths are used to adjust the PLLs.

[0016] The system also handles false locking and switching transients. A false lock occurs if the system locks on a frequency that does not correspond to the resonant frequency of the sensor. In one aspect of the invention, the system avoids false locks by examining how the phase difference signal goes to zero. If the slope of the phase difference signal relative to time meets a predetermined direction, e.g. positive, then the PLL is allowed to lock. However, if the slope of the phase difference signal relative to time does not meet the predetermined direction, e.g. it is negative, then the signal strength is suppressed to prevent a false lock.

[0017] Another aspect of the invention uses frequency dithering to avoid a false lock. A constant pulse repetition frequency can add spectral components to the sensor signal and cause a false lock. By randomly varying the pulse repetition frequency of the energizing signal, the sidebands move back and forth so that the average of the sidebands is reduced. Thus, the system locks on the center frequency rather than the sidebands.

[0018] In another aspect of the invention, phase dithering can be used to reduce switching transients. The phase of the energizing signal and a local oscillator (referred to herein as local oscillator 1) are randomly changed. Varying the phase of the energizing signal varies the phase of the coupled signal, but does not affect the phase of the transient signal. Thus, the average of the transient signal is reduced. Changing the resonant frequency of the coil as it is switched from energizing mode to coupling mode also reduces switching transients. The capacitors that are connected to the coil are switched between different modes to slightly change the resonant frequency in order to reduce switching transients.

[0019] These and other aspects, features and advantages of the present invention may be more clearly understood and appreciated from a review of the following detailed description of the disclosed embodiments and by reference to the appended drawings and claims.

BRIEF DESCRIPTION OF THE DRAWINGS

[0020]

Figure 1 is a block diagram of an exemplary system for communicating with a wireless sensor.

Figure 2(a) is a graph illustrating an exemplary energizing signal

Figures 2(b), 2(c) and 2(d) are graphs illustrating exemplary coupled signals.

Figure 3 is a block diagram of an exemplary base unit.

Figures 4(a) and 4(b) are graphs illustrating exemplary phase difference signals.

Figure 5 illustrates frequency dithering.

Figure 6 illustrates phase dithering.

Figure 7 illustrates a coupling loop.

Figure 8 is a graph illustrating an exemplary charging response of an LC circuit.

Figure 9 is a block diagram of a portion of an exemplary base unit.

Figure 10 is a block diagram of a portion of an exemplary base unit in accordance with the invention.

DETAILED DESCRIPTION

[0021] The present invention is directed towards a system and method for communicating with a wireless sensor. Briefly described, the present invention determines the resonant frequency of the sensor by adjusting the phase and frequency of an energizing signal until the frequency of this signal locks to the resonant frequency of the sensor. The system energizes the sensor with a low duty cycle, gated burst of RF energy of a predetermined frequency or set of frequencies and predetermined amplitude. This signal induces a current in the sensor that can be used to track the resonant frequency of the sensor. The system receives the ring down response of the sensor and determines the resonant frequency of the sensor, which is used to calculate the measured physical parameter. The system uses a pair of phase locked loops ("PLL"s) to adjust the phase and the frequency of the energizing signal to track the resonant frequency of the sensor.

[0022] The preferred embodiment of the invention is defined by figure 10 in connection with figure 10 in connection with figure 3.

Exemplary System

[0023] Figure 1 illustrates an exemplary system for communicating with a wireless sensor implanted within a body. The system includes a coupling loop 100, a base unit 102, a display device 104 and an input device 106, such as a keyboard.

[0024] The coupling loop is formed from a band of copper. In one embodiment, the loop is eight inches in diameter. The coupling loop includes switching and filtering circuitry that is enclosed within a shielded box 101. The loop charges the sensor and then couples signals from the sensor into the receiver. The antenna can be shielded to attenuate in-band noise and electromagnetic emissions.

[0025] Another possible embodiment for a coupling loop is shown in Figure 7, which shows separate loops for energizing 702 and for receiving 704, although a single loop can be used for both functions. PIN diode switching inside the loop assembly is used to provide isolation between the energizing phase and the receive phase by opening the RX path pin diodes during the energizing period, and opening the energizing path pin diodes during the coupling period. Multiple energizing loops can be staggered tuned to achieve a wider bandwidth of matching between the transmit coils and the transmit circuitry.

[0026] The base unit includes an RF amplifier, a receiver, and signal processing circuitry. Additional details of the circuitry are described below in connection with Figure 3.

[0027] The display 104 and the input device 106 are used in connection with the user interface for the system. In the embodiment illustrated in Figure 1 the display device and the input device are connected to the base unit. In this embodiment, the base unit also provides conventional computing functions. In other embodiments, the base unit can be connected to a conventional computer, such as a laptop, via a communications link, such as an RS-232 link. If a separate computer is used, then the display device and the input devices associated with the computer can be used to provide the user interface. In one embodiment, LABVIEW software is used to provide the user interface, as well as to provide graphics, store and organize data and perform calculations for calibration and normalization. The user interface records and displays patient data and guides the user through surgical and follow-up procedures.

[0028] An optional printer 108 is connected to the base unit and can be used to print out patient data or other types of information. As will be apparent to those skilled in the art other configurations of the system, as well as additional or fewer components can be utilized with the invention.

[0029] Patient and system information can be stored within a removable data storage unit, such as a portable USB storage device, floppy disk, smart card, or any other similar device. The patient information can be transferred to the physician's personal computer for analysis, review, or storage. An optional network connection can be provided to automate storage or data transfer. Once the data is retrieved from the system, a custom or third party source can be employed to assist the physician with data analysis or storage.

[0030] Figure 1 illustrates the system communicating with a sensor 120 implanted in a patient. The system is

used in two environments: 1) the operating room during implant and 2) the doctor's office during follow-up examinations. During implant the system is used to record at least two measurements. The first measurement is taken during introduction of the sensor for calibration and the second measurement is taken after placement for functional verification of the stent graft. The measurements can be taken by placing the coupling loop either on or adjacent to the patient's back or the patient's stomach for a sensor that measures properties associated with an abdominal aneurysm. For other types of measurements, the coupling loop may be placed in other locations. For example, to measure properties associated with the heart, the coupling loop can be placed on the patient's back or the patient's chest.

[0031] The system communicates with the implanted sensor to determine the resonant frequency of the sensor. As described in more detail in the patent documents referenced in the Background section, a sensor typically includes an inductive-capacitive ("LC") resonant circuit having a variable capacitor. The distance between the plates of the variable capacitor varies as the surrounding pressure varies. Thus, the resonant frequency of the circuit can be used to determine the pressure.

[0032] The system energizes the sensor with an RF burst. The energizing signal is a low duty cycle, gated burst of RF energy of a predetermined frequency or set of frequencies and a predetermined amplitude. Typically, the duty cycle of the energizing signal ranges from 0.1% to 50%. In one embodiment, the system energizes the sensor with a 30-37.5 MHz fundamental signal at a pulse repetition rate of 100 kHz with a duty cycle of 20%. The energizing signal is coupled to the sensor via a magnetic loop. This signal induces a current in the sensor which has maximum amplitude at the resonant frequency of the sensor. During this time, the sensor charges exponentially to a steady-state amplitude that is proportional to the coupling efficiency, distance between the sensor and loop, and the RF power. Figure 8 shows the charging response of a typical LC circuit to a burst of RF energy at its resonant frequency. The speed at which the sensor charges is directly related to the Q (quality factor) of the sensor. Therefore, the "on time" of the pulse repetition duty cycle is optimized for the Q of the sensor. The system receives the ring down response of the sensor via magnetic coupling and determines the resonant frequency of the sensor. Figure 2(a) illustrates a typical energizing signal and Figures 2(b), 2(c) and 2(d) illustrate typical coupled signals for various values of Q (quality factor) for the sensor. When the main unit is coupling energy at or near the resonant frequency of the sensor, the amplitude of the sensor return is maximized, and the phase of the sensor return will be close to zero degrees with respect to the energizing phase. The sensor return signal is processed via phase-locked-loops to steer the frequency and phase of the next energizing pulse.

Operation of the Base Unit

[0033] Figure 3 is a block diagram of the signal processing components within an exemplary base unit.

5 The base unit determines the resonant frequency of the sensor by adjusting the energizing signal so that the frequency of the energizing signal matches the resonant frequency of the sensor. In the embodiment illustrated by Figure 3, two separate processors 302, 322 and two separate coupling loops 340, 342 are shown. In one embodiment, processor 302 is associated with the base unit and processor 322 is associated with a computer connected to the base unit. In other embodiments, a single processor is used that provides the same functions as the two separate processors. In other embodiments a single loop is used for both energizing and for coupling the sensor energy back to the receiver. As will be apparent to those skilled in the art, other configurations of the base unit are possible that use different components.

10 **[0034]** The embodiment illustrated by Figure 3 includes a pair of phase lock loops ("PLL"). One of the PLLs is used to adjust the phase of the energizing signal and is referred to herein as the fast PLL. The other PLL is used to adjust the frequency of the energizing signal and is referred to herein as the slow PLL. The base unit provides two cycles: the calibration cycle and the measurement cycle. In one embodiment, the first cycle is a 10 microsecond energizing period for calibration of the system, which is referred to herein as the calibration cycle, and the second cycle is a 10 microsecond energizing/coupling period for energizing the sensor and coupling a return signal from the sensor, which is referred to herein as the measurement cycle. During the calibration cycle, the system generates a calibration signal for system and environmental phase calibration and during the measurement cycle the system both sends and listens for a return signal, *i.e.* the sensor ring down. Alternatively, as those skilled in the art will appreciate, the calibration cycle and the measurement cycle can be implemented in the same pulse repetition period.

15 **[0035]** The phase of the energizing signal is adjusted during the calibration cycle by the fast PLL and the frequency of the energizing signal is adjusted during the measurement cycle by the slow PLL. The following description of the operation of the PLLs is presented sequentially for simplicity. However, as those skilled in the art will appreciate, the PLLs actually operate simultaneously.

20 **[0036]** Initially the frequency of the energizing signal is set to a default value determined by the calibration parameters of the sensor. Each sensor is associated with a number of calibration parameters, such as frequency, offset, and slope. An operator of the system enters the sensor calibration parameters into the system via the user interface and the system determines an initial frequency for the energizing signal based on the particular sensor. Alternatively, the sensor calibration information could be stored on portable storage devices, bar codes,

or incorporated within a signal returned from the sensor. The initial phase of the energizing signal is arbitrary.

[0037] The initial frequency and the initial phase are communicated from the processor 302 to the DDSs (direct digital synthesizers) 304, 306. The output of DDS 1304 is set to the initial frequency and initial phase and the output of DDS2 306 (also referred to as local oscillator 1) is set to the initial frequency plus the frequency of the local oscillator 2. The phase of DDS2 is a fixed constant. In one embodiment, the frequency of local oscillator 2 is 4.725 MHz. The output of DDS1 is gated by the field programmable gate array (FPGA). 308 to create a pulsed transmit signal having a pulse repetition frequency ("PRF"). The FPGA provides precise gating so that the base unit can sample the receive signal during specific intervals relative to the beginning or end of the calibration cycle.

[0038] During the calibration cycle, the calibration signal which enters the receiver 310 is processed through the receive section 311 and the IF section 312, and is sampled. In one example, the calibration signal is the portion of the energizing signal that leaks into the receiver (referred to herein as the energizing leakage signal). The signal is sampled during the on time of the energizing signal by a sample and hold circuit 314 to determine the phase difference between the signal and local oscillator 2. Figure 3 illustrates two cascaded sample and holds in circuit 314 to provide both fast sampling and a long hold time. Alternatively, a single sample and hold can be used in circuit 314. If the calibration signal is the portion of the energizing signal that leaks into the receiver, the signal is sampled approximately 100 ns after the beginning of the energizing signal pulse. Since the energizing signal is several orders of magnitude greater than the coupled signal, it is assumed that the phase information associated with the leaked signal is due to the energizing signal and the phase delay is due to the circuit elements in the coupling loop, circuit elements in the receiver, and environmental conditions, such as proximity of reflecting objects.

[0039] The phase difference is sent to a loop filter 316. The loop filter is set for the dynamic response of the fast PLL. In one embodiment, the PLL bandwidth is 1000 Hz and the damping ratio is 0.7. A DC offset is added to allow for positive and negative changes. The processor 302 reads its analog to digital converter (A/D) port to receive the phase difference information and adjusts the phase sent to direct digital synthesizer 1 (DDS1) to drive the phase difference to zero. This process is repeated alternatively until the phase difference is zero or another reference phase.

[0040] The phase adjustment made during the energizing period acts to zero the phase of the energizing signal with respect to local oscillator 2. Changes in the environment of the antenna or the receive chain impedance, as well as the phase delay within the circuitry prior to sampling affect the phase difference reading and are accommodated by the phase adjustment.

[0041] During the measurement cycle, the energizing signal may be blocked from the receiver during the on time of the energizing signal. During the off time of the energizing signal, the receiver is unblocked and the coupled signal from the sensor (referred to herein as the coupled signal or the sensor signal) is received. The coupled signal is amplified and filtered through the receive section 311. The signal is down converted and additional amplification and filtering takes place in the IF section 312. In one embodiment, the signal is down converted to 4.725 MHz. After being processed through the IF section, the signal is mixed with local oscillator 2 and sampled by sample and hold circuits 315 to determine the phase difference between the coupled signal and the energizing signal. Figure 3 illustrates two cascaded sample and holds in circuit 315 to provide both fast sampling and a long hold time. Alternatively, a single sample and hold can be used in circuit 315. For instance the sampling occurs approximately 30 ns after the energizing signal is turned off.

[0042] Group delay or signal amplitude may also be used to determine the resonant frequency of the sensor. The phase curve of a second order system passes through zero at the resonant frequency. Since the group delay (i.e. the derivative of the phase curve) reaches a maximum at the resonant frequency, the group delay can be used to determine the resonant frequency. Alternatively, the amplitude of the sensor signal can be used to determine the resonant frequency. The sensor acts like a bandpass filter so that the sensor signal reaches a maximum at the resonant frequency.

[0043] The sampled signal is accumulated within a loop filter 320. The loop filter is set for the dynamic response of the slow PLL to aid in the acquisition of a lock by the slow PLL. The PLLs are implemented with op-amp low pass filters that feed A/D inputs on microcontrollers 302 and 322 which in turn talk to the DDSs 304 and 306 which provide the energizing signal and local oscillator 1. The microcontroller that controls the energizing DDS 304 also handles communication with the display. The response of the slow PLL depends upon whether the loop is locked or not. If the loop is unlocked, then the bandwidth is increased so that the loop will lock quickly. In one embodiment, the slow PLL has a damping ratio of 0.7 and a bandwidth of 120 Hz when locked (the Nyquist frequency of the blood pressure waveform), which is approximately ten times slower than the fast PLL.

[0044] A DC offset is also added to the signal to allow both a positive and a negative swing. The output of the loop filter is input to an A/D input of processor 322. The processor determines a new frequency and sends the new frequency to the DDSs. The processor offsets the current frequency value of the energizing signal by an amount that is proportional to the amount needed to drive the output of the slow PLL loop filter to a preset value. In one embodiment the preset value is 2.5V and zero in phase. The proportional amount is determined by the PLL's overall transfer function.

[0045] The frequency of the energizing signal is deemed to match the resonant frequency of the sensor when the slow PLL is locked. Once the resonant frequency is determined, the physical parameter, such as pressure, is calculated using the calibration parameters associated with the sensor, which results in a difference frequency that is proportional to the measured pressure.

[0046] The operation of the slow PLL is qualified based on signal strength. The base unit includes signal strength detection circuitry. If the received signal does not meet a predetermined signal strength threshold, then the slow PLL is not allowed to lock and the bandwidth and search window for the PLL are expanded. Once the received signal meets the predetermined signal strength threshold, then the bandwidth and search window of the slow PLL is narrowed and the PLL can lock. In the preferred embodiment, phase detection and signal strength determination are provided via the "I" (in phase) and "Q" (quadrature) channels of a quadrature mixer circuit. The "I" channel is lowpass filtered and sampled to provide signal strength information to the processing circuitry. The "Q" channel is lowpass filtered and sampled (THSS, THSS2) to provide phase error information to the slow PLL.

[0047] The base unit includes two switches, RX blocking switches 350 and 352, that aid in the detection of the sensor signal. One of the RX blocking switches precedes the preselector in the receive section 311 and the other RX blocking switch follows the mixer in the IF section 312. The FPGA controls the timing of the RX blocking switches (control signals not shown). The RX blocking switches are closed during the on time of the energizing signal during the calibration cycle and generally closed during the off time of the energizing signal during the measurement cycle. During the measurement cycle the timing of the RX blocking switches is similar to the timing of the switch that controls the energizing signal into the receiver during the measurement cycle, but the RX blocking switches are closed slightly later to account for signal travel delays in the system. The RX blocking switches prevent the energizing signal that leaks into the receiver during the measurement cycle (specifically during the on time of the energizing signal) from entering the IF section. If the leakage signal enters the IF section, then it charges the IF section and the IF section may not settle out before the sensor signal arrives. For example, in one instance the IF section was charged for several hundred nanoseconds after the on time of the energizing signal. Blocking the leakage signal from the IF section eliminates this problem and improves detection of the sensor signal.

Base Unit Implementing Multiple Sampling Points

[0048] An alternative base unit not forming part of the invention uses multiple sampling points rather than the single sampling point discussed above in connection with Figure 3. If a single sampling point is used and the sampling point coincides with a point where the average DC voltage of the phase detector is zero, then the system

can lock even though the frequency is not the correct frequency. This situation can occur when there is system stress, such as a DC offset in the loop integrator or some other disturbance. The use of multiple sampling points helps prevent a false lock under these circumstances.

[0049] Figure 9 illustrates a portion of the base unit using two sampling points, S1, S2. The components illustrated in Figure 9 are used instead of the sample and hold components 314, 315 used in Figure 3. As discussed above in connection with Figure 3, this base unit uses a pair of PLLs. The phase of the energizing signal is adjusted by the fast PLL and the frequency of the energizing signal is adjusted by the slow PLL. However, in this case only a single cycle is needed to adjust the phase and frequency of the energizing signal, i.e. separate calibration and measurement cycles are not necessary. Since only a single cycle is used, the timing of the RX blocking switches is slightly different than that described above in connection with Figure 3. In this embodiment, the RX blocking switches are generally closed during the off time of the energizing signal. The specific timing of the closure of the RX blocking switches may be system specific and can be adjusted to account for signal travel delays in the system.

[0050] The initial frequency and phase of the energizing signal are set as described above in connection with Figure 3. The energizing signal may be blocked from the receiver during the on time of the energizing signal. During the off time of the energizing signal, the receiver is unblocked and the coupled signal from the sensor is received. The coupled signal is amplified and filtered through the receive section 311. The signal is down converted and additional amplification and filtering takes place in the IF section 312. For example, the signal is down converted to 4.725 MHz. After being processed through the IF section the signal is mixed with local oscillator 2 and sampled by the two sample and hold circuits 915a and 915b to determine the phase difference between the coupled signal and the energizing signal.

[0051] The two sample points are applied to a first differential amplifier 950 and a second differential amplifier 952. The first differential amplifier outputs a signal representing the difference between the two sampling points (S2 - S1), which is fed into the loop filter 320 and used to adjust the frequency of the energizing signal. The second differential amplifier 952 outputs a signal representing the sum of the two sampling points (S1 + S2), which is fed into the loop filter 316 and used to adjust the phase of the energizing signal.

[0052] The FPGA controls the timing of the two sample and hold circuits. In one embodiment, the first sample point occurs approximately 30 ns after the energizing signal is turned off and the second sample point occurs approximately 100 to 150 ns after the energizing signal is turned off. The timing of the first sampling point is selected so that the first sampling point occurs soon after the switching and filter transients have settled out. The timing of the second sampling point is selected so that there is

sufficient time between the first sampling point and the second sampling point to detect a slope, but before the signal becomes too noisy.

[0053] The frequency of the energizing signal is deemed to match the resonant frequency of the sensor when the slow PLL is locked. Once the resonant frequency is determined, the physical parameter, such as pressure, is calculated using the calibration parameters associated with the sensor, which results in a difference frequency that is proportional to the measured pressure.

Base Unit Implementing Continuous Signal Processing

[0054] In this case, the base unit uses continuous signal processing techniques instead of the sampled processing techniques discussed above in connection with Figures 3 and 9. This embodiment derives continuous wave signals from the pulsed calibration signal and the pulsed sensor signal and uses the continuous wave signals to adjust the phase and frequency of the energizing signal.

[0055] Figure 10 illustrates a portion of the base unit for an embodiment that uses continuous signal processing. As illustrated by Figure 10, this embodiment uses separate calibration 1012a and measurement sections 1012b instead of the common IF section 312 and separate sample and hold circuits 314 and 315 used in Figure 3. After the signal passes through the receiver section 311, the mixer, and one of the RX blocking switches, the signal is split into a pair of switches, TX IF switch 1050 and RX IF switch 1052. The FPGA controls the switches (control signals not shown) so that the TX IF switch 1050 is closed and the RX IF switch 1052 is opened during the calibration cycle and the TX IF switch is opened and the RX IF switch is closed during the measurement cycle. The calibration section 1012a and the measurement section 1012b each include the aforementioned switch, a low pass filter, a narrow bandpass filter, amplifiers and a phase detector. The common IF section of Figure 3 uses a bandpass filter, typically on the order of 2-3 MHz whereas the calibration and measurements sections of Figure 10 use a narrow bandpass filter, typically on the order of 60 - 120 kHz.

[0056] The following description of the embodiment illustrated by Figure 10 uses alternating calibration and measurement cycles. However, the calibration cycle and the measurement cycle can be implemented in the same pulse repetition period.

[0057] During the calibration cycle, the calibration signal which enters the receiver 310 is processed through the receive section 311 and the calibration section 1012a. The phase difference output from the calibration section is sent to the loop filter 316 and the adjustment of the phase of the energizing signal proceeds as described above in connection with Figure 3.

[0058] During the measurement cycle, the energizing signal may be blocked from the receiver during the on time of the energizing signal. During the off time of the

energizing signal, the receiver is unblocked and the sensor signal is received. The coupled signal is amplified and filtered through the receive section 311 and then transferred to the measurement section 1012b. The phase difference output from the measurement section is sent to loop filter 320 and the adjustment of the frequency of the energizing signal proceeds as described above in connection with Figure 3.

[0059] In one embodiment, the RX blocking switches close as described above in connection with Figure 3, but open earlier during the measurement cycle. Instead of being closed through the end of the off time of the energizing signal, the RX blocking switches open before the end of the off time. The timing of the opening of the RX blocking switches is based on the sensor characteristics and is selected so that the switches open once the sensor signal falls below the noise level.

Since most of the energy from sensor signal is received within a time period of Q/f_0 , where Q is the Q of the sensor and f_0 is the center frequency of the sensor, the RX blocking switches can be opened after approximately Q/f_0 . For example, if the Q of the sensor is 40 and the f_0 is 32 MHz, then the RX blocking switches are opened after approximately 1.25 microseconds during the measurement cycle. The Q of the sensor and an approximate f_0 of the sensor are typically known and can be used to control the timing of the RX blocking switches.

[0060] In the examples that use sample and hold techniques, only the sampled information is used and the noise after the sample point(s) is ignored. However, in this continuous signal processing, all of the noise is seen unless other adjustments are made. Opening the RX blocking switches once the sensor signal decays below the noise level helps reduce the noise seen by the rest of the system and improves detection of the sensor signal.

[0061] The frequency spectrum of the sensor signal includes a number of spectral components that correspond to the pulse repetition frequency, including a strong component corresponding to the center frequency of the energizing signal (f_0). The information needed to determine the resonant frequency of the sensor can be obtained by examining the phase of the spectral component that corresponds to f_0 . The measurement section isolates the spectral component at f_0 and the resulting time domain signal is a continuous wave signal.

[0062] In some embodiments, the system generates an energizing signal with a random or pseudo random frame width (i.e. period of pulse repetition). For example, the pulse width is 2 microseconds for each frame, but the frame size is pseudo randomly selected from one of four possible frame sizes: 6.22 microseconds, 8.76 microseconds, 11.30 microseconds and 13.84 microseconds. The use of four frame sizes is exemplary. Any number of frame sizes can be used, although at some point increasing the number of possible frame sizes increases the system complexity with only incremental improvements.

[0063] The minimum frame sizes corresponds to the smallest frame size that provides a sufficient receive window and typically corresponds to the pulse width. For example, if the pulse width is 2 microseconds, then the minimum receive window is also 2 microseconds making the minimum frame size 4 microseconds. However, switching times and other practical considerations related to the components used may result in a slightly larger frame size. The maximum frame size is typically based on a desired average pulse repetition rate. In this example, if the average pulse repetition period is selected as 10 microseconds, then the maximum frame size is 14 microseconds.

[0064] If a random or pseudo random frame width is used, then the frame width can vary between the calibration cycle and the measurement cycle or a common frame width can be used for a calibration cycle and the following measurement cycle. The use of a random or pseudo random frame width helps isolate the spectral component needed to determine the resonant frequency of the sensor and relaxes the requirements of the narrow bandpass filter used in the receive section. The use of a random or pseudo random frame width or PRF is also discussed in connection with frequency dithering in the section entitled "Avoiding False Locks."

[0065] As an alternative to the embodiment illustrated by Figure 10, the RX blocking switch 352 is combined with the TX IF switch 1050 and the RX IF switch 1052 and the control of the TX IF and the RX IF switches are modified to accommodate the combination.

Avoiding False Locks

[0066] The system provides unique solutions to the false lock problem. A false lock occurs if the system locks on a frequency that does not correspond to the resonant frequency of the sensor. There are several types of false locks. The first type of false lock arises due to the pulsed nature of the system. Since the energizing signal is a pulsed signal, it includes groups of frequencies. The frequency that corresponds to a false lock is influenced by the pulse repetition frequency, the Q of the sensor, and the duty cycle of the RF burst. For example, a constant pulse repetition frequency adds spectral components to the return signal at harmonic intervals around the resonant frequency of the sensor, which can cause a false lock. In one embodiment, false locks occur at approximately 600 kHz above and below the resonant frequency of the sensor. To determine a false lock, the characteristics of the signal are examined. For example, pulse repetition frequency dithering and/or observing the slope of the baseband signal are two possible ways of determine a false lock. In one embodiment where the system locks on a sideband frequency, the signal characteristics correspond to a heartbeat or a blood pressure waveform.

[0067] The second type of false lock arises due to a reflection or resonance of another object in the vicinity of the system. This type of false lock can be difficult to

discern because it generally does not correspond to a heartbeat or blood pressure waveform. The lack of frequency modulation can be used to discriminate against this type of false lock. Changing the orientation of the magnetic loop also affects this type of false lock because the reflected false lock is sensitive to the angle of incidence.

[0068] The third type of false lock arises due to switching transients caused by switching the PIN diodes and analog switches in the RF path. These transients cause damped resonances in the filters in the receive chain, which can appear similar to the sensor signal. Typically, these types of false locks do not correspond to a heartbeat or blood pressure waveform because they are constant frequency. These types of false locks are also insensitive to orientation of the magnetic loop.

[0069] To avoid the first type of false lock, the present invention determines the slope of the baseband signal (the phase difference signal at point 330). In one embodiment, if the slope is positive, then the lock is deemed a true lock. However, if the slope is negative, then the lock is deemed a false lock. In another embodiment, a negative slope is deemed a true lock and a positive slope is deemed a false lock. The slope is determined by looking at points before and after the phase difference signal goes to zero. The slope can be determined in a number of different ways, including but not limited to, using an analog differentiator or multiple sampling. Figures 4(a) and 4(b) illustrate a true lock and a false lock respectively, when a positive slope indicates a true lock. In one embodiment, if a false lock is detected, then the signal strength is suppressed so that the signal strength appears to the processor 322 to be below the threshold and the system continues to search for the center frequency. In other embodiments, any non-zero slope can be interpreted as a false lock resulting in zero signal strength.

[0070] The system can also use frequency dithering to avoid the first type of false lock. Since the spectral components associated with a constant pulse repetition frequency can cause a false lock, dithering the pulse repetition frequency helps avoid a false lock. By dithering the pulse repetition frequency, the spectral energy at the potential false lock frequencies is reduced over the averaged sampling interval. As shown in Figure 5, the energizing signal includes an on time t_1 and an off time t_2 . The system can vary the on time or the off time to vary the PRF ($PRF = 1/(t_1 + t_2)$). Figure 5 illustrates different on times (t_1, t_1') and different off times (t_2, t_2'). By varying the PRF, the sidebands move back and forth and the average of the sidebands is reduced. Thus, the system locks on the center frequency rather than the sidebands. The PRF can be varied between predetermined sequences of PRFs or can be varied randomly.

Reducing Switching Transients

[0071] The coupling loop switches between an energizing mode and a coupling mode. This switching creates

transient signals, which can cause the third type of false lock. Phase dithering is one method used to reduce the switching transients. As shown in Figure 6, the system receives a switching transient 603 between the end of the energizing signal 602 and the beginning of the coupled signal 604. To minimize the transient, the phase of the energizing signal may be randomly changed. However, changing the phase of the energizing signal requires that the system redefine zero phase for the system. To redefine zero phase for the system, the phase of DDS2 is changed to match the change in phase of the energizing signal. Thus, the phase of the energizing signal 602' and the coupled signal 604' are changed, but the phase of the transient signal 603' is not. As the system changes phase, the average of the transient signal is reduced.

[0072] Changing the resonant frequency of the antenna as it is switched from energizing mode to coupling mode also helps to eliminate the switching transients. Eliminating the switching transients is especially important in the present invention because of the characteristics of the coupled signal. The coupled signal appears very quickly after the on period of the energizing signal and dissipates very quickly. In one embodiment, the invention operates in a low power environment with a passive sensor so that the magnitude of the coupled signal is small. However, the invention is not limited to working with a passive sensor.

[0073] The coupling loop is tuned to a resonant frequency that is based upon the sensor parameters. Changing the capacitors or capacitor network that is connected to the coupling loop changes the resonant frequency of the antenna. The resonant frequency typically is changed from approximately 0.1% to 2% between energizing mode and coupled mode. In some embodiments, the coupling loop is untuned.

[0074] Additional alternative embodiments will be apparent to those skilled in the art to which the present invention pertains without departing from its scope. For example, the system can operate with different types of sensors, such as non-linear sensors that transmit information at frequencies other than the transmit frequency or sensors that use backscatter modulations. Accordingly, the scope of the present invention is described by the appended claims and is supported by the foregoing description.

Claims

1. A method for determining a resonant frequency of a wireless sensor, using a measurement section (1012b) and a separate calibration section (1012a), the method comprising the following steps :

- A) adjusting a phase of an energizing signal by:
 - i) receiving a calibration signal during a cal-

- ibration cycle;
- ii) processing the calibration signal during a first period within the calibration cycle to create a continuous wave intermediate frequency calibration using the calibration section;
- iii) determining a first phase difference between the continuous wave calibration signal and a reference signal using the calibration section; and,
- iv) based on the first phase difference adjusting the phase of the energizing signal to reduce the first phase difference;

B) adjusting a frequency of the energizing signal by:

- v) receiving a sensor signal from the wireless sensor during a measurement cycle;
- vi) processing the sensor signal during a period within the measurement cycle to create a continuous wave intermediate frequency sensor signal using the measurement section;
- vii) determining a second phase difference between the continuous wave sensor signal and the energizing signal using the measurement section;
- viii) based on the second phase difference adjusting the frequency of the energizing signal to reduce the second phase difference; and
- ix) determining the frequency of the energizing signal when the second phase difference corresponds to a predetermined value; and
- x) using the frequency of the energizing signal when the second phase difference corresponds to the predetermined value to determine the resonant frequency of the sensor.

2. A method as claimed in Claim 1, wherein generating the energizing signal comprises adjusting a pulse repetition period of the energizing signal between a first calibration cycle and a second calibration cycle.

3. A method as claimed in Claim 2 wherein the frame width is adjusted randomly or pseudo randomly.

4. A method as claimed in any preceding claim, wherein processing the calibration signal during a first period within the calibration cycle comprises allowing the calibration signal to propagate into the calibration section (1012a) during the first period.

5. A method as claimed in any preceding claim, further comprising preventing the calibration signal from

propagating into the measurement section (1012b) during the calibration cycle.

6. A method as claimed in any preceding claim, wherein adjusting the phase of the energizing signal comprises using a first phase locked loop, PLL, and adjusting the frequency of the energizing signal comprises using a second PLL. 5
7. A method as claimed in any preceding claim, wherein adjusting a phase of an energizing signal is repeated until the first phase difference between the continuous wave calibration signal and the reference signal corresponds to a first predetermined value. 10
8. A method as claimed in any preceding claim, wherein processing the sensor signal during a period within the measurement cycle comprises allowing the sensor signal to propagate into the measurement section (1012b) during the period. 20
9. A method as claimed in any preceding claim, further comprising: using the resonant frequency of the sensor to determine a physical parameter associated with the sensor. 25
10. A method as claimed in any preceding claim, wherein adjusting a frequency of the energizing signal is repeated until the phase difference corresponds to the predetermined value. 30
11. A method as claimed in any preceding claim, wherein processing the sensor signal during a period within the measurement cycle comprises processing the sensor signal to determine a center frequency of the sensor signal. 35
12. A system for determining a resonant frequency of a wireless sensor the system comprising means to adjust a frequency of an energizing signal, said means comprising 40

- i) a receive section for receiving a calibration signal and a sensor signal;
ii) a calibration path comprising: 45

a) a calibration section (1012a) for processing the calibration signal to create a continuous wave intermediate frequency calibration signal, determining a first phase difference between the energizing signal and the continuous wave calibration signal; and
b) a first phase lock loop, PLL, for adjusting a phase of the energizing signal based on the phase difference between the energizing signal and the continuous wave calibration signal; 50

55

iii) a measurement path comprising:

c) a measurement section (1012b), separate from the calibration section, for processing the sensor signal to create a continuous wave intermediate frequency sensor signal, determining a phase difference between the energizing signal and the continuous wave sensor signal; and,
d) a second PLL for adjusting a frequency of the energizing signal based on the phase difference between the energizing signal and the continuous wave sensor signal.

13. A system as claimed in Claim 12, further comprising:

an energizing signal generator for randomly or pseudo randomly varying a frame width of the energizing signal between the calibration cycle and the following measurement cycle.

14. A system as claimed in any of Claims 12 or 13, wherein the calibration section creates a continuous wave calibration signal using a narrow bandpass filter. 25

15. A system as claimed in any of Claims 12-14, wherein the measurement section creates a continuous wave sensor signal using a narrow bandpass filter. 30

16. A system as claimed in any of Claims 12-15, further comprising: a control for controlling propagation of the sensor signal into the measurement section. 35

17. A system as claimed in any of Claims 12-16, further comprising: a control for controlling propagation of the calibration signal into the calibration section (1012a). 40

Patentansprüche

1. Verfahren zur Bestimmung einer Resonanzfrequenz eines drahtlosen Sensors unter Verwendung eines Messabschnitts (1012b) und eines separaten Kalibrierungsabschnitts (1012a), wobei das Verfahren die folgenden Schritte umfasst:

A) Einstellen einer Phase eines Erregersignals durch:

- i) Empfang eines Kalibriersignals während eines Kalibrierzyklus;
ii) Verarbeitung des Kalibriersignals während einer ersten Periode innerhalb des Kalibrierzyklus, um ein Dauerstrich-Zwischenfrequenz-Kalibriersignal unter Verwendung des Kalibrierungsabschnitts zu erzeugen;

- iii) Bestimmung einer ersten Phasendifferenz zwischen dem Dauerstrich-Kalibriersignal und einem Referenzsignal unter Verwendung des Kalibrierungsabschnitts; und,
iv) basierend auf der ersten Phasendifferenz, das Einstellen der Phase des Erregersignals, um die erste Phasendifferenz zu verringern;
- B) Einstellen einer Frequenz des Erregersignals durch:
- v) Empfang eines Sensorsignals vom drahtlosen Sensor während eines Messzyklus;
vi) Verarbeitung des Sensorsignals während einer Periode innerhalb des Messzyklus, um ein Dauerstrich-Zwischenfrequenz-Sensorsignal unter Verwendung des Messabschnitts zu erzeugen;
vii) Bestimmung einer zweiten Phasendifferenz zwischen dem Dauerstrich-Sensorsignal und dem Erregersignal unter Verwendung des Messabschnitts;
viii) basierend auf der zweiten Phasendifferenz das Einstellen der Frequenz des Erregersignals, um die zweite Phasendifferenz zu verringern; und
ix) Bestimmung der Frequenz des Erregersignals, wenn die zweite Phasendifferenz einem vorbestimmten Wert entspricht; und
x) Verwendung der Frequenz des Erregersignals, wenn die zweite Phasendifferenz dem vorbestimmten Wert entspricht, um die Resonanzfrequenz des Sensors zu bestimmen.
2. Verfahren nach Anspruch 1, wobei das Erzeugen des Erregersignals das Einstellen einer Impulsfolgeperiode des Erregersignals zwischen einem ersten Kalibrierzyklus und einem zweiten Kalibrierzyklus umfasst.
3. Verfahren nach Anspruch 2, wobei die Rahmenbreite zufällig oder pseudozufällig eingestellt wird.
4. Verfahren nach einem der vorhergehenden Ansprüche, wobei die Verarbeitung des Kalibriersignals während einer ersten Periode innerhalb des Kalibrierzyklus umfasst, es dem Kalibriersignal zu ermöglichen, sich in den Kalibrierabschnitt (1012a) während der ersten Periode auszubreiten.
5. Verfahren nach einem der vorhergehenden Ansprüche, ferner umfassend, dass verhindert wird, dass sich das Kalibriersignal während des Kalibrierzyklus in den Messabschnitt (1012b) ausbreitet.
6. Verfahren nach einem der vorhergehenden Ansprüche, wobei das Einstellen der Phase des Erregersignals die Verwendung einer ersten Phasenregelschleife, PLL, umfasst, und das Einstellen der Frequenz des Erregersignals die Verwendung einer zweiten PLL umfasst.
7. Verfahren nach einem der vorhergehenden Ansprüche, wobei das Einstellen einer Phase eines Erregersignals wiederholt wird, bis die erste Phasendifferenz zwischen dem Dauerstrich-Kalibriersignal und dem Referenzsignal einem ersten vorbestimmten Wert entspricht.
8. Verfahren nach einem der vorhergehenden Ansprüche, wobei die Verarbeitung des Sensorsignals während einer Periode innerhalb des Messzyklus umfasst, es dem Sensorsignal zu ermöglichen, sich während der Periode in den Messabschnitt (1012b) auszubreiten.
9. Verfahren nach einem der vorhergehenden Ansprüche, ferner umfassend:
die Verwendung der Resonanzfrequenz des Sensors, um einen mit dem Sensor assoziierten physikalischen Parameter zu bestimmen.
10. Verfahren nach einem der vorhergehenden Ansprüche, wobei das Einstellen einer Frequenz des Erregersignals wiederholt wird, bis die Phasendifferenz dem vorbestimmten Wert entspricht.
11. Verfahren nach einem der vorhergehenden Ansprüche, wobei die Verarbeitung des Sensorsignals während einer Periode innerhalb des Messzyklus die Verarbeitung des Sensorsignals umfasst, um eine Mittenfrequenz des Sensorsignals zu bestimmen.
12. System zur Bestimmung einer Resonanzfrequenz eines drahtlosen Sensors, wobei das System Hilfsmittel umfasst zum Einstellen einer Frequenz eines Erregersignals, wobei die Hilfsmittel umfassen:
i) einen Empfangsabschnitt zum Empfang eines Kalibriersignals und eines Sensorsignals;
ii) eine Kalibrierstrecke, umfassend:
a) einen Kalibrierabschnitt (1012a) zur Verarbeitung des Kalibriersignals, um ein Dauerstrich-Zwischenfrequenz-Kalibriersignal zu erzeugen, Bestimmen einer ersten Phasendifferenz zwischen dem Erregersignal und dem Dauerstrich-Kalibriersignal; und
b) eine erste Phasenregelschleife, PLL, zum Einstellen einer Phase des Erregersignals basierend auf der Phasendifferenz zwischen dem Erregersignal und dem Dauerstrich-Kalibriersignal;

- iii) eine Messstrecke, umfassend:
- c) einen Messabschnitt (1012b), getrennt vom Kalibrierabschnitt, zur Verarbeitung des Sensorsignals, um ein Dauerstrich-Zwischenfrequenz-Sensorsignal zu erzeugen, Bestimmen einer Phasendifferenz zwischen dem Erregersignal und dem Dauerstrich-Sensorsignal; und
 - d) eine zweite PLL zum Einstellen einer Frequenz des Erregersignals, basierend auf der Phasendifferenz zwischen dem Erregersignal und dem Dauerstrich-Sensorsignal.
13. System nach Anspruch 12, ferner umfassend:
- einen Erregersignal-Generator zur zufälligen oder pseudozufälligen Variation einer Rahmenbreite des Erregersignals zwischen dem Kalibrierzyklus und dem folgenden Messzyklus.
14. System nach einem der Ansprüche 12 oder 13, wobei der Kalibrierabschnitt ein Dauerstrich-Kalibrierabschnitt unter Verwendung eines Schmalbandfilters erzeugt.
15. System nach einem der Ansprüche 12 bis 14, wobei der Messabschnitt ein Dauerstrich-Sensorsignal unter Verwendung eines Schmalbandfilters erzeugt.
16. System nach einem der Ansprüche 12 bis 15, ferner umfassend: eine Steuerung zum Steuern der Ausbreitung des Sensorsignals in den Messabschnitt.
17. System nach einem der Ansprüche 12 bis 16, ferner umfassend: eine Steuerung zum Steuern der Ausbreitung des Kalibriersignals in den Kalibrierabschnitt (1012a).

Revendications

1. Procédé de détermination d'une fréquence de résonance d'un capteur sans fil en utilisant une section de mesure (1012b) et une section d'étalonnage séparée (1012a), le procédé comprenant les étapes suivantes consistant à :
- A) ajuster une phase d'un signal d'excitation :
 - i) en recevant un signal d'étalonnage au cours d'un cycle d'étalonnage ;
 - ii) en traitant le signal d'étalonnage au cours d'une première période du cycle d'étalonnage pour créer un signal d'étalonnage de fréquence intermédiaire à onde continue en utilisant la section d'étalonnage ;

- iii) en déterminant une première différence de phase entre le signal d'étalonnage à onde continue et un signal de référence en utilisant la section d'étalonnage ; et,
- iv) sur la base de la première différence de phase, en ajustant la phase du signal d'excitation pour réduire la première différence de phase ;

B) ajuster une fréquence du signal d'excitation:

- v) en recevant un signal du capteur sans fil au cours d'un cycle de mesure ;
 - vi) en traitant le signal du capteur au cours d'une période du cycle de mesure pour créer un signal de capteur de fréquence intermédiaire à onde continue en utilisant la section de mesure ;
 - vii) en déterminant une seconde différence de phase entre le signal du capteur à onde continue et le signal d'excitation en utilisant la section de mesure ;
 - viii) sur la base de la seconde différence de phase, en ajustant la fréquence du signal d'excitation pour réduire la seconde différence de phase ;
 - ix) en déterminant la fréquence du signal d'excitation lorsque la seconde différence de phase correspond à une valeur prédéterminée ; et
 - x) en utilisant la fréquence du signal d'excitation lorsque la seconde différence de phase correspond à la valeur prédéterminée pour déterminer la fréquence de résonance du capteur.
2. Procédé selon la revendication 1, dans lequel la génération du signal d'excitation comprend l'ajustement d'une période de répétition d'impulsions du signal d'excitation entre un premier cycle d'étalonnage et un second cycle d'étalonnage.

3. Procédé selon la revendication 2, dans lequel la largeur de la trame est ajustée de manière aléatoire ou pseudo aléatoire.

4. Procédé selon l'une quelconque des revendications précédentes, dans lequel le traitement du signal d'étalonnage au cours d'une première période du cycle d'étalonnage comprend l'étape permettant au signal d'étalonnage de se propager dans la section d'étalonnage (1012a) au cours de la première période.

5. Procédé selon l'une quelconque des revendications précédentes, comprenant en outre l'étape visant à empêcher le signal d'étalonnage de se propager dans la section de mesure (1012b) au cours du cycle

- d'étalonnage.
6. Procédé selon l'une quelconque des revendications précédentes, dans lequel l'ajustement de la phase du signal d'excitation comprend l'utilisation d'une première boucle verrouillée en phase, PLL, et l'ajustement de la fréquence du signal d'excitation comprend l'utilisation d'une seconde PLL. 5
7. Procédé selon l'une quelconque des revendications précédentes, dans lequel l'ajustement d'une phase d'un signal d'excitation est répété jusqu'à ce que la première différence de phase entre le signal d'étalonnage à onde continue et le signal de référence corresponde à une première valeur prédéterminée. 10 15
8. Procédé selon l'une quelconque des revendications précédentes, dans lequel le signal du capteur au cours d'une période du cycle de mesure comprend l'étape permettant au signal du capteur de se propager dans la section de mesure (1012b) au cours de la période. 20
9. Procédé selon l'une quelconque des revendications précédentes, comprenant en outre l'utilisation de la fréquence de résonance du capteur pour déterminer un paramètre physique associé au capteur. 25
10. Procédé selon l'une quelconque des revendications précédentes, dans lequel l'ajustement d'une fréquence du signal d'excitation est répété jusqu'à ce que la différence de phase corresponde à la valeur prédéterminée. 30
11. Procédé selon l'une quelconque des revendications précédentes, dans lequel le traitement du signal du capteur au cours d'une période du cycle de mesure comprend le traitement du signal du capteur pour déterminer une fréquence centrale dudit signal. 35
12. Système de détermination d'une fréquence de résonance d'un capteur sans fil, le système comprenant des moyens pour ajuster une fréquence d'un signal d'excitation, lesdits moyens comprenant : 40
- i) une section réceptrice pour recevoir un signal d'étalonnage et un signal de capteur ;
 - ii) un trajet d'étalonnage comprenant : 45
 - a) une section d'étalonnage (1012a) pour traiter le signal d'étalonnage afin de créer un signal d'étalonnage de fréquence intermédiaire à onde continue et déterminer une première différence de phase entre le signal d'excitation et le signal d'étalonnage à onde continue ; et 50
 - b) une première boucle verrouillée en phase, PLL, pour ajuster une phase du signal 55
- d'excitation sur la base de la différence de phase entre le signal d'excitation et le signal d'étalonnage à onde continue ;
- iii) un trajet de mesure comprenant :
- c) une section de mesure (1012b) séparée de la section d'étalonnage pour traiter le signal du capteur afin de créer un signal de capteur de fréquence intermédiaire à onde continue et déterminer une différence de phase entre le signal d'excitation et le signal du capteur à onde continue ; et
 - d) une seconde PLL pour ajuster une fréquence du signal d'excitation sur la base de la différence de phase entre le signal d'excitation et le signal du capteur à onde continue.
13. Système selon la revendication 12, comprenant en outre :
- un générateur de signal d'excitation pour faire varier de manière aléatoire ou pseudo aléatoire une largeur de trame du signal d'excitation entre le cycle d'étalonnage et le cycle de mesure suivant.
14. Système selon l'une quelconque des revendications 12 ou 13, dans lequel la section d'étalonnage crée un signal d'étalonnage à onde continue en utilisant un filtre à bande passante étroite.
15. Système selon l'une quelconque des revendications 12 à 14, dans lequel la section de mesure crée un signal de capteur à onde continue en utilisant un filtre à bande passante étroite.
16. Système selon l'une quelconque des revendications 12 à 15, comprenant en outre une commande pour commander la propagation du signal du capteur dans la section de mesure.
17. Système selon l'une quelconque des revendications 12 à 16, comprenant en outre une commande pour commander la propagation du signal d'étalonnage dans la section d'étalonnage (1012a).

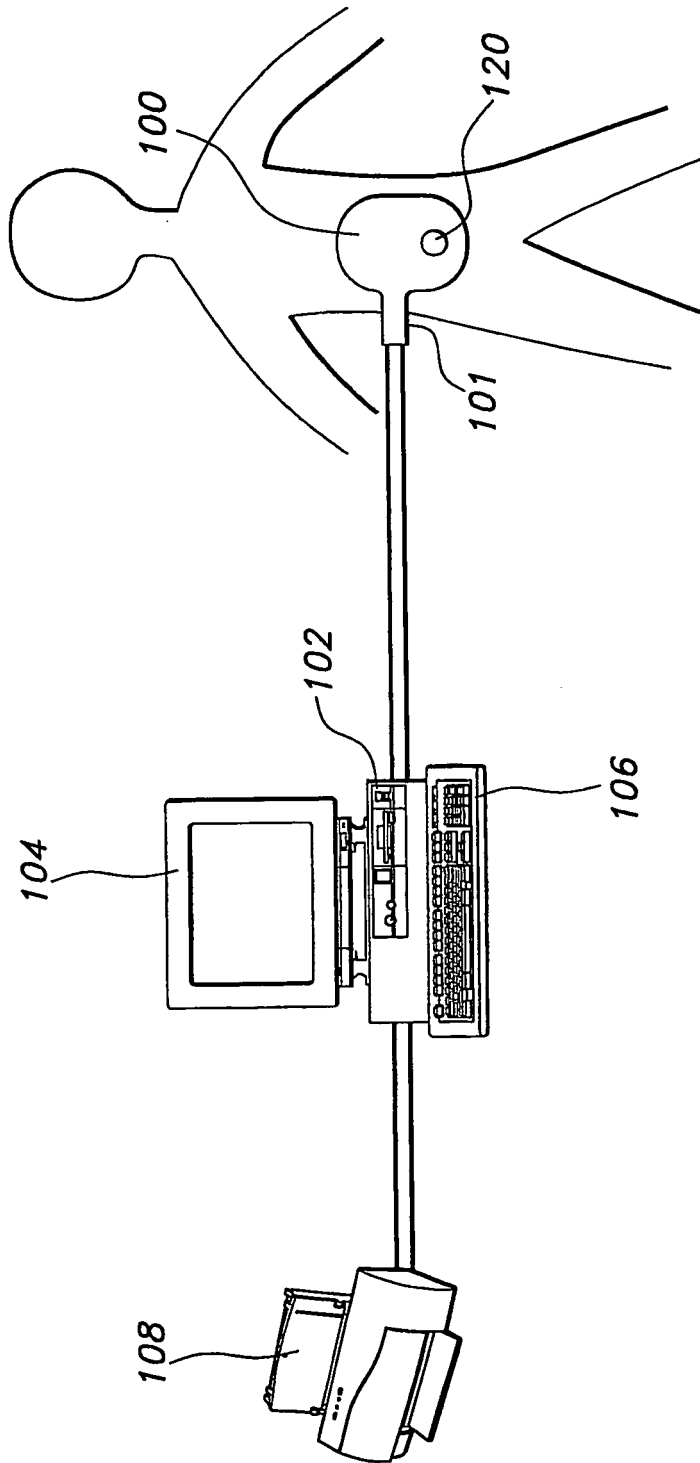

FIG. 1

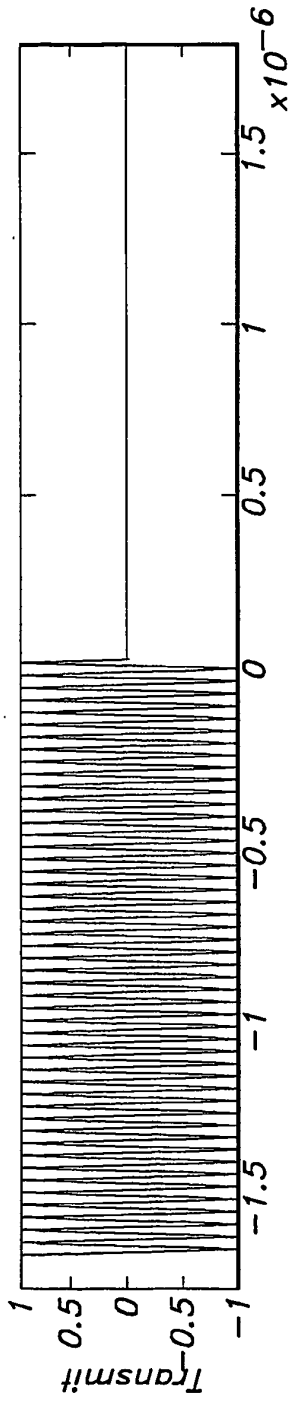

FIG. 2a

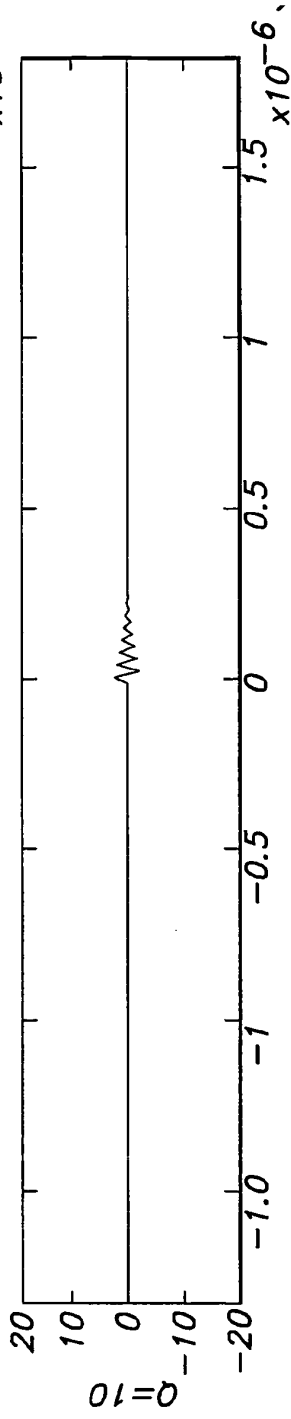

FIG. 2b

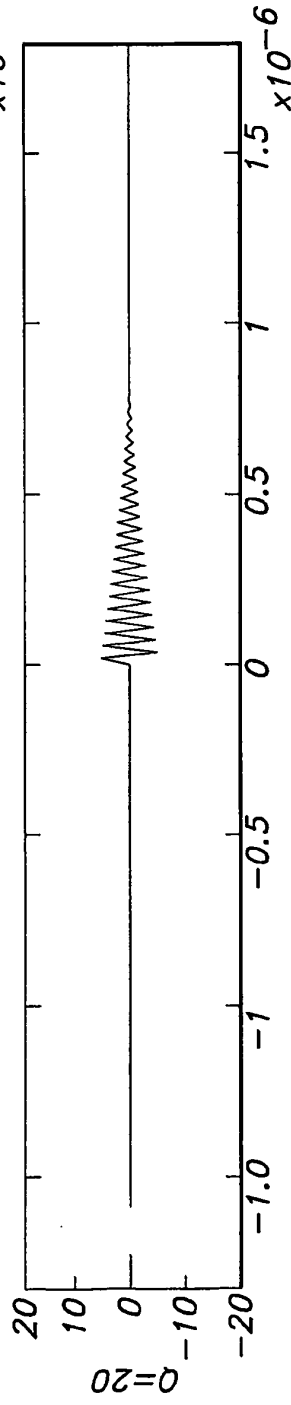

FIG. 2c

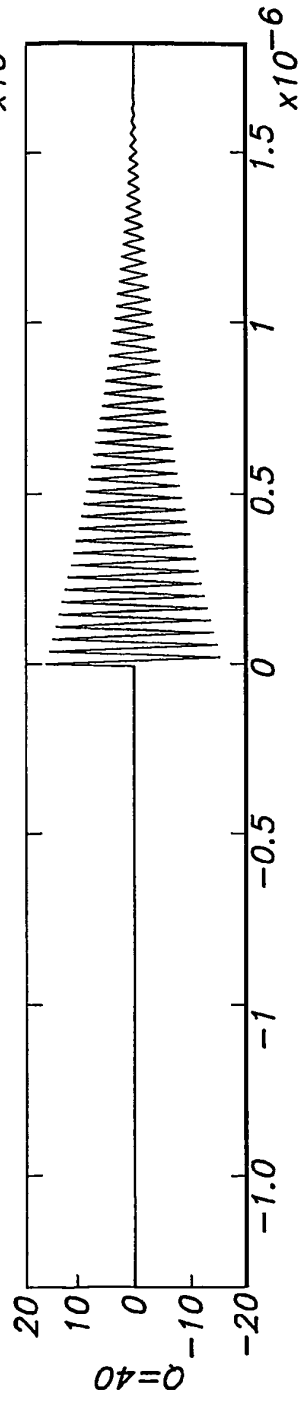

FIG. 2d

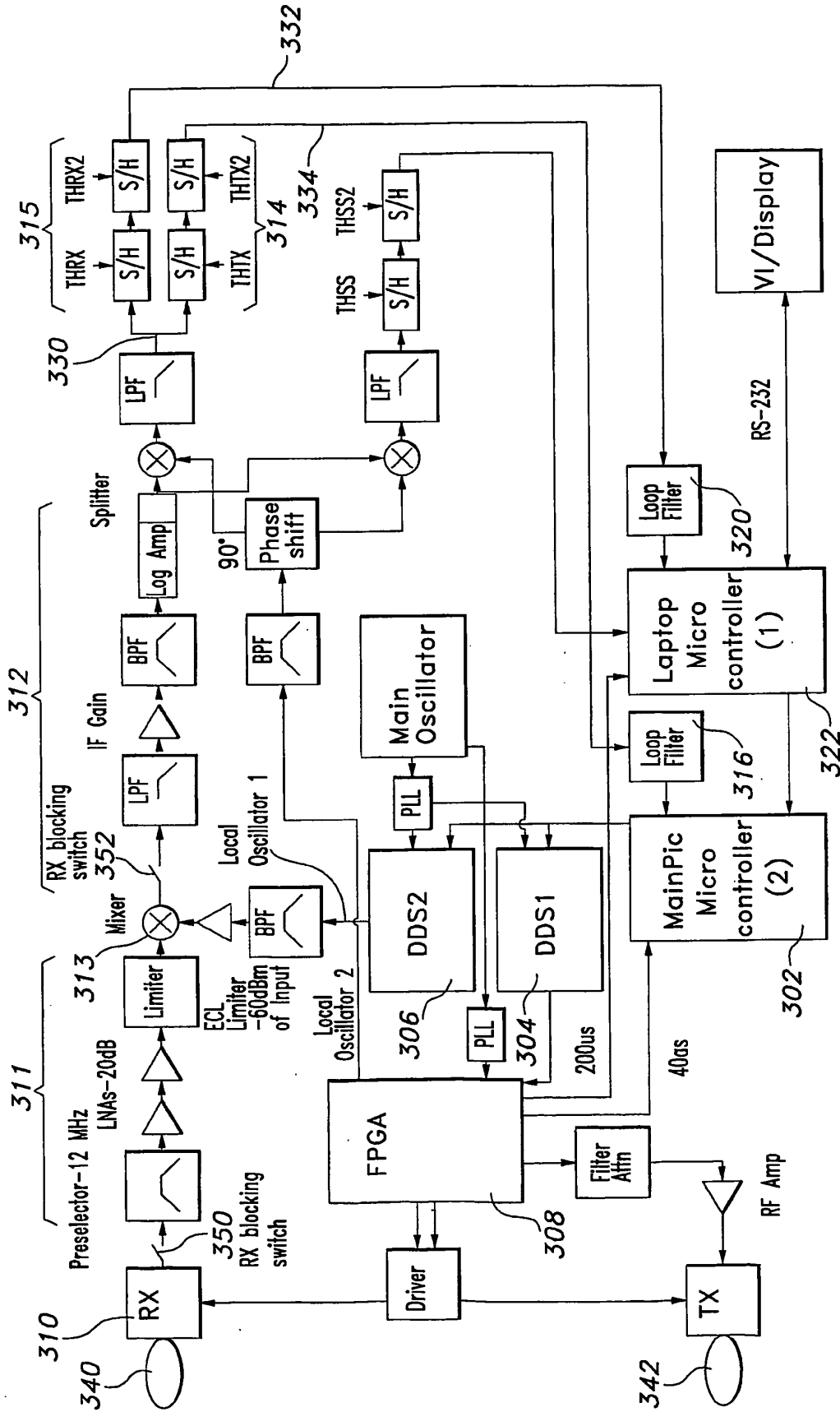

FIG. 3

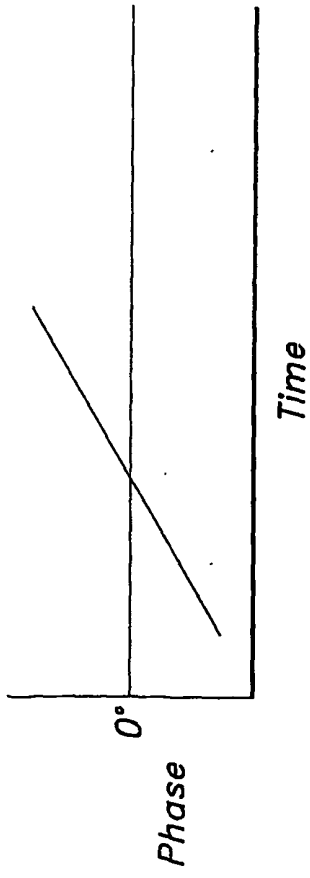

FIG. 4a

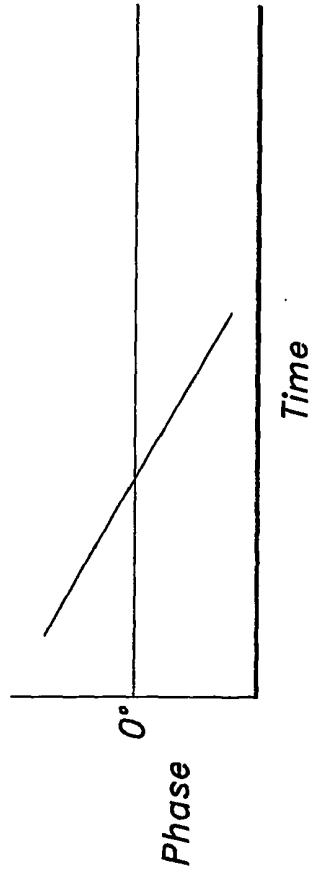

FIG. 4b

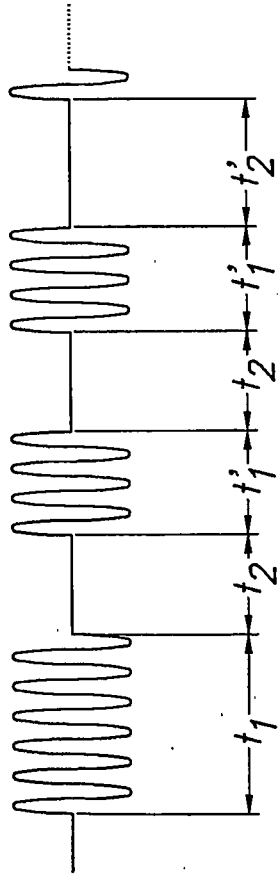

FIG. 5

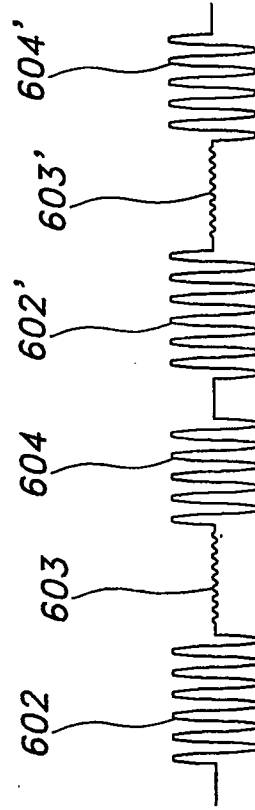

FIG. 6

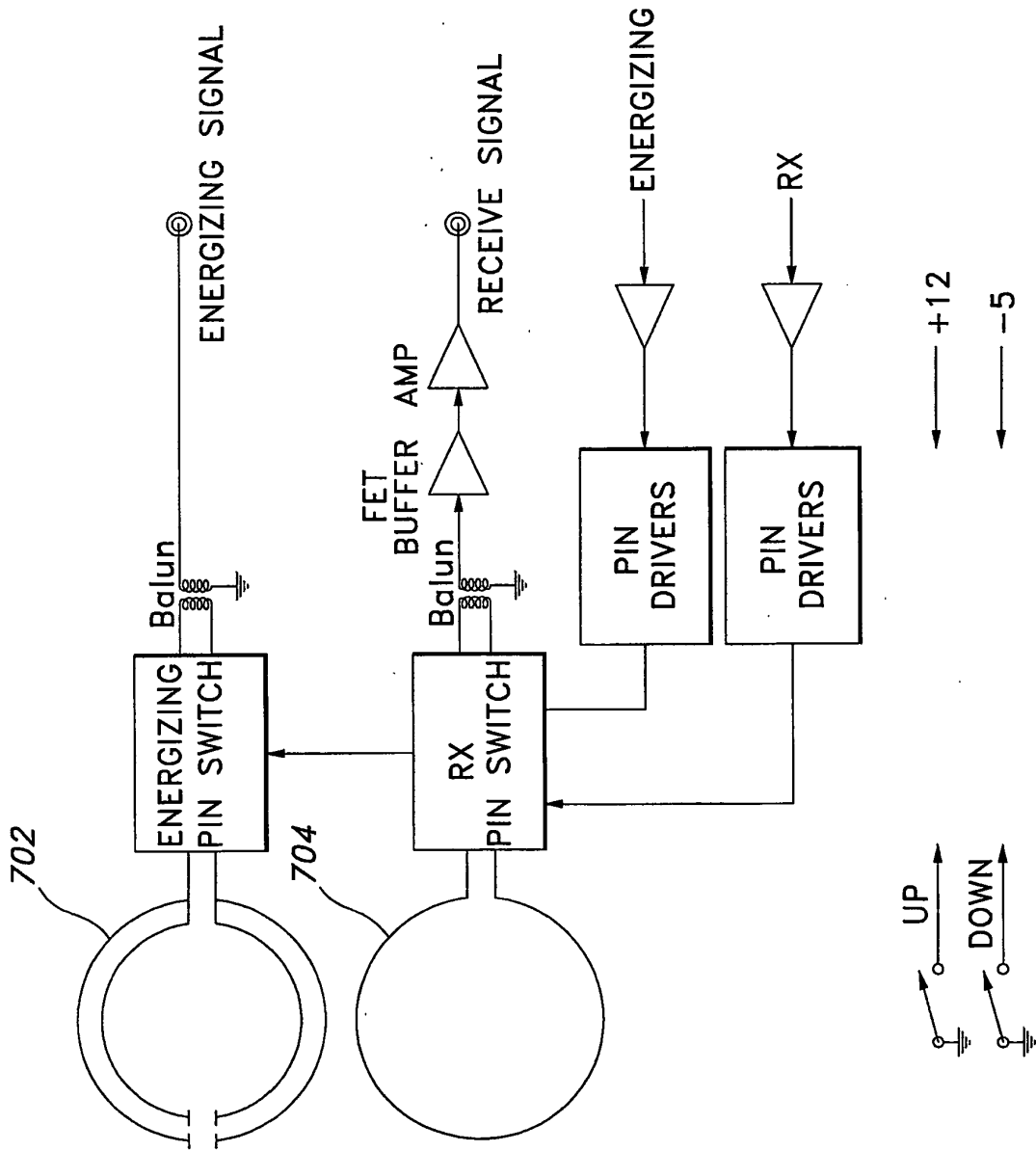

FIG. 7

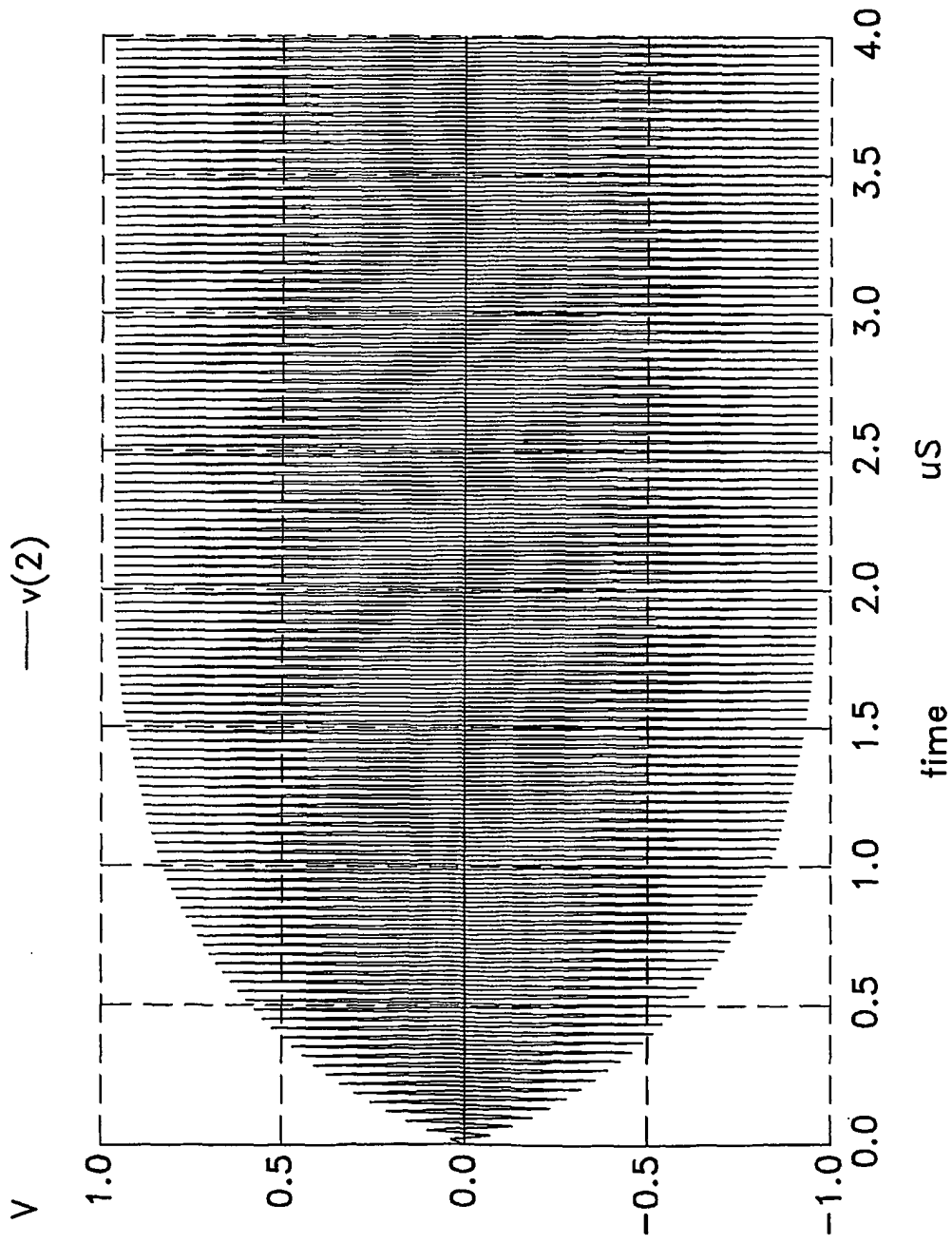

FIG. 8

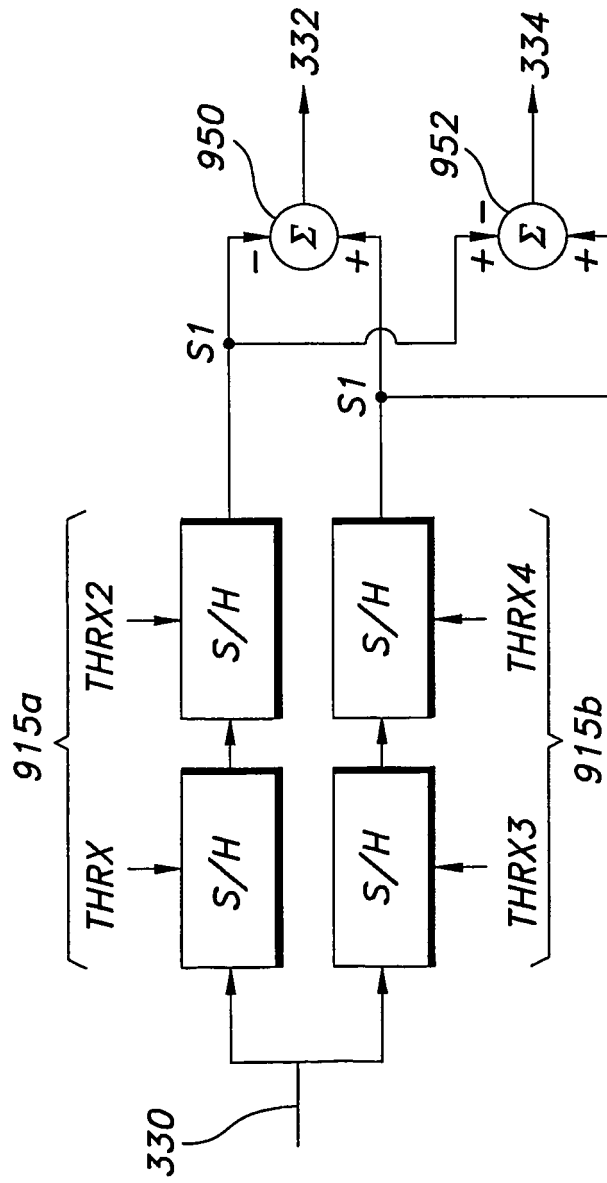

FIG. 9

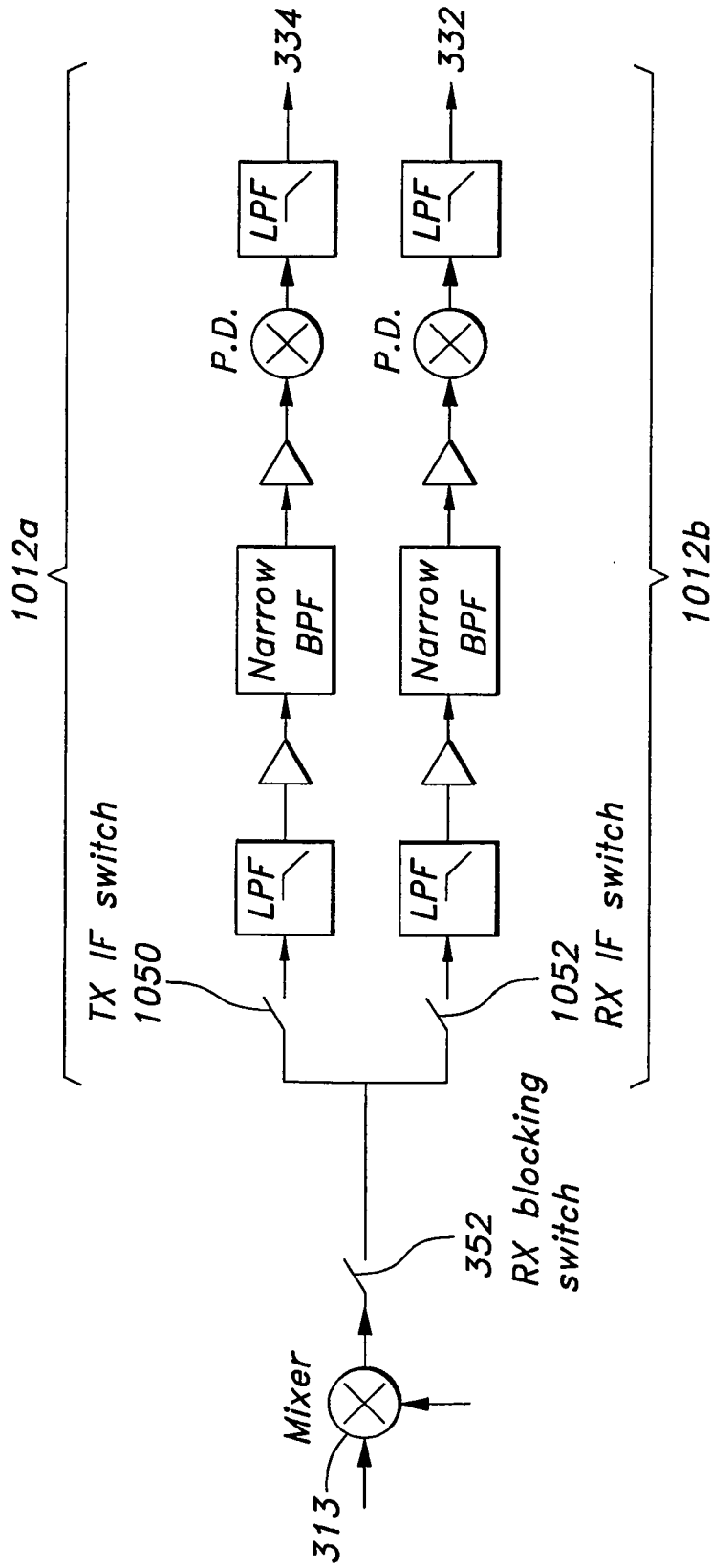

FIG. 10

REFERENCES CITED IN THE DESCRIPTION

This list of references cited by the applicant is for the reader's convenience only. It does not form part of the European patent document. Even though great care has been taken in compiling the references, errors or omissions cannot be excluded and the EPO disclaims all liability in this regard.

Patent documents cited in the description

- US 6111520 A [0002] [0004]
- US 6855115 B [0002]
- US 20030136417 A [0002]

专利名称(译)	与植入的无线传感器通信		
公开(公告)号	EP1876945B1	公开(公告)日	2012-12-05
申请号	EP2006737020	申请日	2006-03-06
[标]申请(专利权)人(译)	的CardioMEMS		
申请(专利权)人(译)	的CardioMEMS , INC.		
当前申请(专利权)人(译)	的CardioMEMS , INC.		
[标]发明人	ALLEN MARK KROH JASON MILLER DONALD ELLIS MICHAEL		
发明人	ALLEN, MARK KROH, JASON MILLER, DONALD ELLIS, MICHAEL		
IPC分类号	A61B5/00		
CPC分类号	G01R23/145 A61B5/0002 A61B5/0031 A61B5/05 A61B5/076 A61B2560/0219 A61B2560/0223 G01F15/066 G01R23/12 H04L2027/0028 H04L2027/0055 H04L2027/0067		
代理机构(译)	B关 , JAMES CHARLES		
优先权	11/105294 2005-04-13 US 60/658680 2005-03-04 US		
其他公开文献	EP1876945A1		
外部链接	Espacenet		

摘要(译)

本发明通过调节激励信号的相位和频率来确定传感器的谐振频率，直到激励信号的频率与传感器的谐振频率匹配。该系统以低占空比激励传感器，具有预定频率或频率组和预定幅度的RF能量的门控脉冲串。激励信号通过磁耦合耦合到传感器，并在传感器中感应出以传感器的谐振频率振荡的电流。系统通过磁耦合接收传感器的振铃响应，并确定传感器的谐振频率，用于计算测量的物理参数。系统使用一对锁相环来调节激励信号的相位和频率。

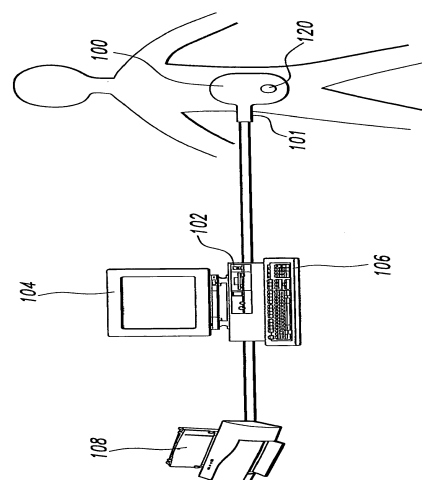

FIG. 1