



(11) **EP 3 148 410 B1**

(12) **EUROPEAN PATENT SPECIFICATION**

(45) Date of publication and mention of the grant of the patent:
21.03.2018 Bulletin 2018/12

(51) Int Cl.:
A61B 5/00 (2006.01) A61B 5/02 (2006.01)
A61B 5/1455 (2006.01) A61B 5/1495 (2006.01)

(21) Application number: **15729556.9**

(86) International application number:
PCT/GB2015/051563

(22) Date of filing: **29.05.2015**

(87) International publication number:
WO 2015/181560 (03.12.2015 Gazette 2015/48)

(54) **TISSUE VARIABILITY COMPENSATION APPARATUS AND METHOD**

VORRICHTUNG UND VERFAHREN FÜR GEWEBEVARIABILITÄTSKOMPENSATION
APPAREIL ET PROCÉDÉ DE COMPENSATION DE LA VARIABILITÉ TISSULAIRE

(84) Designated Contracting States:
AL AT BE BG CH CY CZ DE DK EE ES FI FR GB GR HR HU IE IS IT LI LT LU LV MC MK MT NL NO PL PT RO RS SE SI SK SM TR

(30) Priority: **30.05.2014 GB 201409599**

(43) Date of publication of application:
05.04.2017 Bulletin 2017/14

(73) Proprietor: **Huntleigh Technology Limited**
Bedfordshire LU5 5XF (GB)

(72) Inventors:
• **COOK, Stephen John**
Havant
Hampshire PO9 2SD (GB)

- **BAILLY, Greg**
Cardiff
South Glamorgan CF24 5HN (GB)
- **MORRIS, Philip**
Cardiff
South Glamorgan CF24 5HN (GB)
- **GOUGH, Nigel**
Cardiff
South Glamorgan CF24 5HN (GB)

(74) Representative: **Zacco GmbH**
Bayerstrasse 83
80335 München (DE)

(56) References cited:
GB-A- 2 419 403 US-A1- 2004 204 638

EP 3 148 410 B1

Note: Within nine months of the publication of the mention of the grant of the European patent in the European Patent Bulletin, any person may give notice to the European Patent Office of opposition to that patent, in accordance with the Implementing Regulations. Notice of opposition shall not be deemed to have been filed until the opposition fee has been paid. (Art. 99(1) European Patent Convention).

Description

[0001] The present invention is in the field of medical technology where acquiring physiological signals from a patient (whether human or animal) for subsequent diagnostic interpretation is by the use of non-invasive body surface sensors. These may be separate transmitters and receivers or may have both functions combined into one physical transducer. The sensors may be optical, in which case, the wavelengths used may be either visible or non-visible. In the latter case, they often fall into the infrared spectrum. This type of sensor may have a data connection to downstream data capture and manipulation equipment via an electrical cable or a wireless interface of one of many kinds, such as optical, radio, acoustic, magnetic field, etc.

[0002] The present invention concerns an apparatus and method for compensating for variations in the overall transfer ratio from transmitter input to receiver output between two or more sensors mounted at different anatomical locations. This includes variations due to overall changes in path length arising from different equivalent transmission characteristics through different body locations. Though also suitable for many other skin contact sensors using non-optical transduction principles, such as RF, magnetic field, electric field or vibration, the invention will be illustrated below by the example of an infrared (IR) wavelength transducer combining receiver and transmitter functions, which can be attached to the lower limbs of a patient.

[0003] Physically, a typical non-invasive optical transducer will consist of a cylindrical body with a slightly larger circular base. The base contains two small circular apertures within which are the tips of infrared transmitter and receiver devices. These are spaced apart with a centre-to-centre distance of a few mm.

[0004] For correct operation, the transducer base needs to be in accurate contact with the skin of a patient. This enables a beam of infrared energy to enter the skin and surface tissues to a depth in excess of 2 mm. Random photon to photon scattering within the beam enables a much attenuated signal to be gathered by the receiver device. The transmission path of the photons within the received signal has passed through both the capillary loops and subsurface horizontal structure of small veins and arteries which lies around 2 mm below the skin in a normal healthy adult human.

[0005] The overall transmission attenuation from transmitter to receiver is composed of several elements, including back-scatter and absorption by various anatomical structures such as tissue, ligament etc. That part of the transmitted intensity which reaches sub-surface blood vessels is further reduced by blood volume related absorption and therefore by the time-dependent quantity of blood in both arterial and venous elements of the vasculature.

[0006] However the physical spacing of the transmitter and receiver devices is such that the received signal is

dominated by the blood volumes in the micro-circulation, rather than the larger and deeper veins and arteries. Processing of this received micro-circulation dependent signal in the time and frequency domains can reveal many valuable items of information, which correlate with diseases of both the vasculature and the peripheral nervous system.

[0007] There are several components to the IR energy exiting the tissue which is picked up in the receiver device of the transducer, as follows:

- (a) absorption by pulsating and non-pulsating arterial blood, typically 1% to 2% of the total;
- (b) absorption by venous blood and other tissue, typically <20% of the total; and
- (c) scattering and reflection of incident light, typically >80% of the total.

[0008] In pulse oximetry, only the signal element dependent on pulsating arterial blood is important and the first processing step is to normalise this by dividing by the "dc" component of the received signal which is composed of all the other elements listed above. Averaging a period of received signal or passing the complete signal through a low-pass filter set to remove frequencies above, say, 0.05 Hz will produce a signal value representing the overall effect of scattering and reflection, tissue absorption, non-pulsatile arterial blood absorption, non-time dependent venous blood absorption and averaged low frequency vasomotor time dependent venous blood absorption.

[0009] Normalising by this "dc" signal provides a result which is unaffected by fluctuations in the incident light intensity and is effectively self-calibrating. Thus variations in scattering and reflection of incident light on entering the skin, as well as the transduction ratios of transmitter and receiver and circuit gain tolerances, do not affect the result.

In the alternative situation where the received signal component of interest comes from the time varying element of the venous blood, this signal is composed of:

- (a) a breathing component with energy around the breathing frequency of 5 to 30 breathes per minute; and
- (b) lower frequency local and systemic vasomotor effects on venous blood volume at frequencies from about 0.1 Hz down to below 0.01 Hz.

This signal can also be normalised in a similar manner to the pulsatile arterial signal described above.

As before, a normalising value can be produced by averaging a period of received signal, or passing the complete signal through a low-pass filter set to remove frequencies above, say, 0.05 Hz, so producing a signal value representing the overall effect of scattering and reflection, tissue absorption, non-pulsatile arterial blood absorption, non-time dependent venous blood absorp-

tion and averaged low frequency vasomotor time dependent venous blood absorption.

However, there are also applications where important physiological information is contained in the amplitude of the breathing signal frequency range of venous blood volume variation. In particular, consider an application where a significant amplitude difference in this frequency range, when comparing a pair of transducers in different anatomical locations, is indicative of a certain physiological condition. For example, the transducer pair may be located on contra-lateral parts of the body, such as the left and right upper arms, or the transducers may be mounted on left and right legs below the knee, where the physiological condition of interest may for instance be a lower limb DVT, either above or below the knee. As an example, reference is made to patent document GB2419403. In such a case, the standard method of normalisation with the "dc" signal value described above introduces some problems. The frequency ranges of interest for vasomotor and breathing effects overlap with each other, so an ideal "dc" signal cannot be produced, containing the former with none of the latter, or vice versa. In addition accurate averaging of such low vasomotor frequencies requires long data records, which may not be available or consistent with a short diagnostic process.

[0010] The aim of such normalisation is to remove any effect on signals which does not affect each signal in the pair in the same way. Such differences may be in electronic hardware tolerances, sensor location or anatomy, as follows.

[0011] Hardware tolerances include:

- (a) tolerances in overall circuit gain, including optical transmitter and receiver transduction ratios;
- (b) tolerances in analogue filter frequency responses, particularly the low frequency high-pass "dc" level removing filter; and
- (c) variations with time and temperature in these parameters, which are different between transducers.

[0012] Sensor location differences include:

- (a) skin areas with differing amounts of hair;
- (b) skin conditions on one leg which require the constant use of creams or moisturisers, which include certain dermatological conditions, and skin drying caused by long term use of anti-coagulants; and
- (c) medical conditions on one leg which cause stretching of the skin at the transducer location such as oedema or the swelling associated with post phlebotic syndrome.

[0013] Anatomical differences between contra-lateral sites include:

- (a) varying pigmentation;
- (b) varying degrees of healed scar tissue from leg or pressure ulcers or other wounds; and

(c) variations in tissue attenuation caused by natural tolerances in tissue structures.

[0014] There may also be other problems which affect only one signal of a pair on a momentary basis, such as involuntary patient movement which brings the transducer into contact with other surfaces. Cabled transducers can also suffer from tension problems due to cable weight and stiffness and inevitable cable snags, as well as tension variations created by involuntary patient movement.

[0015] Note that in this latter case, for an asymmetric momentary problem, the averaging or filtering involved in producing a "dc" signal value will generate an asymmetric error which is impossible to remove. Conventionally, such an error can only be prevented by using a sophisticated pattern recognition algorithm, should one be possible, to identify the occurrence of a problem and remove use of this time slot of data on both signals.

[0016] In practice, in order to provide better received signal-to-noise ratios, IR optical transmitters are driven by high level current sources. In order to prevent thermal overload, and consequent thermal runaway and chip destruction, the drive is not continuous, but composed of narrow pulses, typically at a 1 to 3 kHz rate. The transmit pulse modulation signal is used to control a synchronous receiver.

[0017] In line with the present invention, in order to detect and compensate for any differential error between a plurality of transducer signals, including those listed above, an additional signal is introduced into the system.

[0018] Accordingly, in a first aspect, the present invention provides an apparatus for compensating for a differential error between a plurality of body surface sensors for acquiring respective physiological signals from a human or animal patient, each such sensor respectively comprising a transmitter, a receiver, and connected to an output of the respective receiver, a charge-to-voltage converter, the apparatus comprising: a timing signal generator comprising an oscillator, to generate a timing signal; a channel for each respective body surface sensor, each channel comprising: (i) a current modulator to receive said timing signal and supply a current drive signal timed by said timing signal to the transmitter of the respective body surface sensor; (ii) a synchronous receiver to receive said timing signal from the timing signal generator and an output signal timed by said timing signal from the charge-to-voltage converter of the respective body surface sensor and supply a broadband output signal; (iii) an analogue high-pass filter to receive the broadband output signal from the synchronous receiver and supply a filtered output signal; and (iv) an anti-aliasing analogue low-pass filter to receive the filtered output signal from the high-pass filter and supply an anti-aliased output signal; the apparatus further comprising: an analogue-to-digital converter to receive the anti-aliased output signal from the respective channels of each respective body surface sensor and supply a digital output signal for downstream signal processing; wherein the timing

signal generator also generates a digital representation of a sine wave and comprises a digital-to-analogue converter to receive the digital sine wave representation at an update rate higher than the frequency of the timing signal and convert it into an analogue sine wave having a frequency greater than a highest frequency of the physiological signals and less than a cut-off frequency of the anti-aliasing low pass filter; a low-pass filter to receive the analogue sine wave from the digital-to-analogue converter and remove update rate components therefrom to provide a clean sine wave; and an amplitude modulator to receive the clean sine wave from the low-pass filter and add it to the timing signal.

[0019] In a second aspect, the present invention also provides a method of compensating for a differential error between a plurality of body surface sensors, where each sensor respectively comprises a transmitter and a receiver, the method comprising the steps of: adding an amplitude modulated signal to a transmitted signal respectively transmitted by each of said transmitters, the amplitude modulated signal having a frequency: (i) greater than a highest frequency of a physiological signal of a human or animal patient to which the plurality of body surface sensors is applied; and (ii) less than a cut-off frequency of an anti-aliasing low pass filter of an apparatus for processing a received signal respectively received by each of said receivers; applying a band-pass filter to recover the amplitude modulated signal from a plurality of the received signals to provide a respective plurality of compensation signals; comparing the respective amplitudes of the respective plurality of compensation signals with each other; and adjusting the amplitude of at least one of the respective received signals until the amplitudes of the respective plurality of compensation signals are substantially equal to each other.

[0020] Since the sine wave frequency is carefully chosen to be outside the frequency range of physiological interest without significantly changing the analogue filter design requirements, it can easily be subjected to downstream signal processing. For instance, 5 Hz or 300 bpm falls above the maximum cardiac range but well within existing anti-aliasing low pass filter performance.

[0021] This compensation signal can be recovered in each of the signal paths by digital band-pass filtering to provide respective compensation signals. These signals should be of equal amplitude if all physiological signal effects are symmetrical. If they are not, then the ratio of the amplitudes can be used to correct for asymmetrical physiological effects. Note that this correction is carried out in real time and does not require long term signal averaging. If a temporary but significant time-dependent variation in only one compensation signal is detected then this time slot can be removed from each physiological signal before processing.

[0022] As described below, the invention is capable of detecting and compensating for errors introduced by asymmetrical effects on two or more optical transducers mounted on different anatomical locations on humans or

animals. The compensation is real-time, not relying on low pass filtering or averaging, unlike the current method derived from pulse oximetry signal processing. This real-time nature allows the detection and elimination from downstream processing of signal artefacts which do not occur identically in all sensor signals.

[0023] Further features and advantages of the present invention will become apparent from the following detailed description, which is given by way of example and with reference to the accompanying drawings, wherein:

Fig. 1 is a schematic block diagram of the front end of a system excluding detail of a downstream microsystem for signal processing;

Fig. 2 is a perspective view of an illustrative transducer suitable for use with an embodiment of the present invention;

Fig. 3 is a schematic block diagram showing modifications to the system of Fig. 1 for adding a compensation signal in accordance with an embodiment of the invention; and

Fig. 4 is a pair of graphs respectively showing recovered baseband energy spectral density including a compensation signal in left and right channels.

[0024] Referring firstly to Fig. 1, the overall system can be split into two parts, a front end from transducer to analogue-to-digital convertor (adc) digital output and a downstream microprocessor system implementing signal processing, control panel, display and interfacing tasks.

[0025] For simplicity a single channel front end system block diagram is shown. In practice for two or more channels there would be only one timing signal generation circuit 1, 2 feeding all channels. The adc, 11, would be a single adc with multiplexed inputs as all physiological signals from the body are very low frequency compared with typical multiplexer and adc response speeds.

[0026] A 4 MHz crystal 1 is used to provide high accuracy and stability timing signals via a timing generation circuit 2. This provides narrow 1kHz rate pulses to the modulator 3, which has a current drive output modulated between a high and a low, but non-zero level, by the pulse train. This current drive generates energy at a wavelength of 890nm, using a gallium aluminium arsenide IR optical transmitter 5.

[0027] There is also an IR optical receiver in the form of a silicon PIN photodiode with a response range from 750nm to 1100nm, 6. This IR receiver is connected to a local charge to voltage convertor 7, which provides a low source impedance unfiltered broadband voltage output at the 1 kHz pulse rate.

[0028] With reference to Fig. 2, the IR transmitter 5, receiver 6 and charge to voltage convertor 7 are physically housed in a remote cable connected 16, transducer body 15. This has a total height of 10mm, and consists of a cylindrical body 25mm in diameter and with a slightly larger 28mm diameter circular base 2mm thick, 14. The

base contains two small circular apertures within which are the tips of infra-red transmitter 18, and receiver 17, devices. These are spaced apart with a centre to centre distance 6mm. In normal operation the transducer base is in accurate contact with skin of a patient. This provides a beam of IR energy from the IR transmitter 18, into the skin and surface tissues to depth in excess of 2mm. Random photon to photon scattering within the beam enables much attenuated IR energy to be gathered by the IR receiver 17.

[0029] Returning to Fig. 1, the charge to voltage convertor 7, output is fed to a synchronous receiver circuit 8, timed by the same 1 kHz pulse train used to drive the current modulator 3. This synchronous receiver provides a broadband unfiltered output. An analogue high pass filter 9, two pole Sallen and Key, -3dB at 0.07Hz, is used to remove the dc and very low frequency signal component. This would otherwise use up the majority of the adc dynamic range and lower effective resolution for the higher frequency physiological frequencies of interest. Anti-aliasing is provided by an analogue low pass filter 10, two pole Sallen and Key, -3dB at 6Hz.

[0030] The filtered baseband signal is fed to an adc 11, with the digital output used for all other signal processing within a conventional microprocessor system which is not shown in detail.

[0031] With reference to Fig. 3, in order to add a compensation signal to the system, only parts of the circuit providing current drive to the IR transmitter need to change. The same crystal 1 now provides timing to a modified timing generation circuit. This consists of PIC microcontroller implementing timing in software 21 rather than hardware, and containing an integral 12 bit digital-to-analogue convertor (dac) 22. A 1 kHz pulse train is generated as before via a digital output port but also a digital sine wave representation. This is fed to the integral dac at a 20.48 kHz update rate. The dac output is low-pass filtered, single pole R-C, -3dB at 20Hz, to remove update rate components and provide a clean sine wave at exactly 5Hz. This is fed together with the 1 kHz pulse stream to a new amplitude modulator 24.

[0032] This provides a 1 kHz pulse stream, now amplitude modulated at 5Hz to the same current drive modulator 3 as before. The sine wave amplitude, and therefore the amplitude modulation depth is adjusted in healthy volunteer testing to use up no more than 5% of the analogue-to-digital converter (adc) dynamic range. This ensures that this compensation signal addition does not significantly decrease the adc resolution for the physiological signal components of interest.

[0033] For two or more transducers there would only be a single system (1, 21, 22, 23, 24) supplying an amplitude modulated 1 kHz pulse stream to the individual channel current modulators 3.

[0034] The effect of this is to provide a phantom physiological signal at 5Hz in the receive system, but one of known and identical original amplitude for all channels. Since 5Hz is within the filter pass band range used, it

passes relatively unaffected through to the digital domain via the adc as a narrow energy spectral density distribution centred at 5Hz.

[0035] Fig. 4 shows the result of applying a Fast Fourier Transform (FFT) to a typical single channel adc digital output from each of two transducers below the knee on the right (plot RL) and left (plot LL) respectively. The FFT was 64k point performed on a six minute data record using a Hamming window and the results are shown graphically in arbitrary energy units (y axis) versus frequency in cycles per minute (x axis). The key energy spectral density variations are easily categorised by inspecting the energy peaks reading from right to left:

- 15 (a) at 300bpm, the 5Hz compensation signal;
- (b) at approximately 165bpm, the second harmonic of the cardiac rate;
- (c) at approximately 110bpm, the first harmonic of the cardiac rate;
- 20 (d) at approximately 55bpm, the cardiac rate fundamental;
- (e) at approximately 15bpm, the breathing fundamental frequency; and
- 25 (f) below 15bpm, low frequency energy from vasomotor effects.

[0036] The 5Hz compensation signal component can easily be removed from this overall signal without affecting any other physiological component of interest by digital band pass filtering. A first order Butterworth digital band-pass filter is used, centre frequency 5Hz and bandwidth 0.5Hz. The data record is filtered in each direction to remove the time delay effects of the filter. This action is repeated four times to give an overall effect approximately equivalent to an eighth order filter.

Example

[0037] By way of an example, consider the situation of a pair of such optical sensors located 100 mm above the medial malleolus on the left and right legs of a patient.

[0038] Let the signal from the left-leg transducer, after 5Hz component removal, be $S_{le}(t)$.

Let the signal from the right-leg transducer, after 5Hz component removal, be $S_{ri}(t)$.

Let the 5Hz component amplitude extracted from the left-leg overall transducer signal be 5_{le} .

Let the 5Hz component amplitude extracted from the right-leg overall transducer signal be 5_{ri} .

50 Then multiply $S_{ri}(t)$ by $5_{le}/5_{ri}$ to form $S_{riComp}(t)$.

$S_{le}(t)$ and $S_{riComp}(t)$ are now compensated for the differences in transmit and receive hardware tolerances, as well as differences in effective attenuation between the IR optical paths of the left and right leg transducers.

55 Note that the signals 5_{le} and 5_{ri} can be either instantaneous single samples or averaged over variable but identical time periods up to the complete duration of $S_{le}(t)$ and $S_{ri}(t)$, to suit the result required.

Claims

1. An apparatus for compensating for a differential error between a plurality of body surface sensors for acquiring respective physiological signals from a human or animal patient, each such sensor respectively comprising a transmitter, a receiver, and connected to an output of the respective receiver, a charge-to-voltage converter, the apparatus comprising:

a timing signal generator (2, 21) comprising an oscillator (1), to generate a timing signal;
a channel for each respective body surface sensor, each channel comprising:

- (i) a current modulator (3) to receive said timing signal and supply a current drive signal timed by said timing signal to the transmitter of the respective body surface sensor;
- (ii) a synchronous receiver (8) to receive said timing signal from the timing signal generator (2, 21) and an output signal timed by said timing signal from the charge-to-voltage converter (7) of the respective body surface sensor and supply a broadband output signal;
- (iii) an analogue high-pass filter (9) to receive the broadband output signal from the synchronous receiver (8) and supply a filtered output signal; and
- (iv) an anti-aliasing analogue low-pass filter (10) to receive the filtered output signal from the high-pass filter (9) and supply an anti-aliased output signal;

the apparatus further comprising:

an analogue-to-digital converter (11) to receive the anti-aliased output signal from the respective channels of each respective body surface sensor and supply a digital output signal for downstream signal processing;
wherein the timing signal generator (2, 21) also generates a digital representation of a sine wave and comprises a digital-to-analogue converter (22) to receive the digital sine wave representation at an update rate higher than the frequency of the timing signal and convert it into an analogue sine wave having a frequency greater than a highest frequency of the physiological signals and less than a cut-off frequency of the anti-aliasing low pass filter (10);
a low-pass filter (23) to receive the analogue sine wave from the digital-to-analogue converter (22) and remove update rate components therefrom to provide a clean sine wave; and
an amplitude modulator (24) to receive the clean

sine wave from the low-pass filter (23) and add it to the timing signal.

- 2. An apparatus according to claim 1, wherein the oscillator (1) is a crystal with a natural frequency substantially equal to 4 MHz.
- 3. An apparatus according to claim 1 or claim 2, wherein the timing signal generator (2, 21) generates a timing signal with a frequency of from 500 to 1500 Hz, preferably from 750 to 1250 Hz, and most preferably substantially equal to 1 kHz.
- 4. An apparatus according to any one of the preceding claims, wherein the analogue high-pass filter (9) is a two-pole, Sallen-Key filter providing -3dB at about 0.07 Hz.
- 5. An apparatus according to any one of the preceding claims, wherein the anti-aliasing analogue low-pass filter (10) is a two-pole, Sallen-Key filter providing -3dB at about 6 Hz.
- 6. An apparatus according to any one of the preceding claims, wherein the update rate is substantially equal to 20.48 kHz.
- 7. An apparatus according to any one of the preceding claims, wherein the low-pass filter (23) is a single-pole, R-C filter providing -3dB at about 20 Hz.
- 8. An apparatus according to any one of the preceding claims, further comprising a plurality of body surface sensors (15), each such sensor respectively comprising:
 - a transmitter (5, 18);
 - a receiver (6, 17); and, connected to an output of the respective receiver,
 - a charge-to-voltage converter (7).
- 9. An apparatus according to claim 8, wherein the transmitter (5, 18) is a gallium aluminium arsenide infrared optical transmitter radiating energy at a wavelength substantially equal to 890 nm, and the receiver (6, 17) is an infrared optical receiver in the form of a silicon PIN photodiode with a response in the range of from 750 to 1100 nm.
- 10. A method of compensating for a differential error between a plurality of body surface sensors, where each sensor respectively comprises a transmitter and a receiver, the method comprising the steps of:
 - adding an amplitude modulated signal to a transmitted signal respectively transmitted by each of said transmitters, the amplitude modulated signal having a frequency:

- (i) greater than a highest frequency of a physiological signal of a human or animal patient to which the plurality of body surface sensors is applied; and
- (ii) less than a cut-off frequency of an anti-aliasing low pass filter of an apparatus for processing a received signal respectively received by each of said receivers;
- applying a band-pass filter to recover the amplitude modulated signal from a plurality of the received signals to provide a respective plurality of compensation signals;
- comparing the respective amplitudes of the respective plurality of compensation signals with each other; and
- adjusting the amplitude of at least one of the respective received signals until the amplitudes of the respective plurality of compensation signals are substantially equal to each other.
11. A method according to claim 10, wherein the frequency of the amplitude modulated signal is greater than a second harmonic of a heartbeat of the human or animal patient.
12. A method according to claim 10 or claim 11, wherein the frequency of the amplitude modulated signal is from 3 to 7 Hz, preferably from 4 to 6 Hz, and most preferably substantially equal to 5 Hz.

Patentansprüche

1. Vorrichtung zum Kompensieren eines Differentialfehlers zwischen einer Vielzahl von Körperoberflächensensoren zum Erfassen jeweiliger physiologischer Signale von einem menschlichen oder tierischen Patienten, wobei jeder derartige Sensor jeweils einen Sender, einen Empfänger und einen mit einem Ausgang des jeweiligen Empfängers verbundenen Ladungs-Spannungs-Wandler umfasst, welche Vorrichtung umfasst:
- einen einen Oszillator (1) umfassenden Taktsignalgenerator (2, 21) zur Erzeugung eines Taktsignals;
- einen Kanal für jeden einzelnen Körperoberflächensensor, wobei jeder Kanal umfasst:
- (i) einen Strommodulator (3) zum Empfangen des Taktsignals und zum Liefern eines durch das Taktsignal zeitlich abgestimmten Stromsteuersignals an den Sender des jeweiligen Körperoberflächensensors;
- (ii) einen Synchronempfänger (8) zum Empfangen des Taktsignals vom Taktsignalgenerator (2, 21) und eines durch das Taktsi-

gnal zeitlich abgestimmten Ausgangssignals vom Ladungs-Spannungs-Wandler (7) des jeweiligen Körperoberflächensensors und zum Liefern eines Breitbandausgangssignals;

(iii) einen analogen Hochpassfilter (9) zum Empfangen des Breitbandausgangssignals vom Synchronempfänger (8) und zum Liefern eines gefilterten Ausgangssignals; und

(iv) einen analogen Anti-Aliasing-Tiefpassfilter (10) zum Empfangen des gefilterten Ausgangssignals vom Hochpassfilter (9) und zum Liefern eines Antialias-Ausgangssignals;

welche Vorrichtung ferner umfasst:

einen Analog-Digital-Wandler (11) zum Empfangen des Antialias-Ausgangssignals von den jeweiligen Kanälen jedes einzelnen Körperoberflächensensors und zum Liefern eines digitalen Ausgangssignals für die Downstream-Signalverarbeitung;

wobei der Taktsignalgenerator (2, 21) auch eine digitale Darstellung einer Sinuswelle erzeugt und einen Digital-Analog-Wandler (22) umfasst, um die digitale Sinuswellendarstellung bei einer als die Frequenz des Taktsignals höheren Aktualisierungsrate zu empfangen, und sie in eine analoge Sinuswelle mit einer Frequenz umzuwandeln, die größer als eine Höchstfrequenz der physiologischen Signale und kleiner als eine Grenzfrequenz des Anti-Aliasing-Tiefpassfilters (10) ist;

einen Tiefpassfilter (23), um die analoge Sinuswelle von dem Digital-Analog-Wandler (22) zu empfangen, und Aktualisierungsratenkomponenten aus dieser zu entfernen, um eine saubere Sinuswelle bereitzustellen; und

einen Amplitudenmodulator (24), um die saubere Sinuswelle vom Tiefpassfilter (23) zu empfangen, und sie dem Taktsignal hinzuzufügen.

2. Vorrichtung nach Anspruch 1, wobei der Oszillator (1) ein Kristall mit einer Eigenfrequenz ist, die im Wesentlichen 4 MHz gleich ist.
3. Vorrichtung nach Anspruch 1 oder Anspruch 2, wobei der Taktsignalgenerator (2, 21) ein Taktsignal mit einer Frequenz von 500 bis 1500 Hz, bevorzugt von 750 bis 1250 Hz, und am meisten bevorzugt im Wesentlichen gleich 1 kHz, erzeugt.
4. Vorrichtung nach einem der vorhergehenden Ansprüche, wobei der analoge Hochpassfilter (9) ein zweipoliger Sallen-Key-Filter ist, welcher -3dB bei etwa 0,07 Hz bereitstellt.

5. Vorrichtung nach einem der vorhergehenden Ansprüche, wobei der analoge Anti-Aliasing-Tiefpassfilter (10) ein zweipoliger Sallen-Key-Filter ist, welcher -3dB bei etwa 6 Hz bereitstellt.

6. Vorrichtung nach einem der vorhergehenden Ansprüche, wobei die Aktualisierungsrate im Wesentlichen gleich 20,48 kHz ist.

7. Vorrichtung nach einem der vorhergehenden Ansprüche, wobei der Tiefpassfilter (23) ein einpoliger R-C-Filter ist, welcher -3dB bei etwa 20 Hz bereitstellt.

8. Vorrichtung nach einem der vorhergehenden Ansprüche, zusätzlich umfassend eine Vielzahl von Körperoberflächensensoren (15), wobei jeder derartige Sensor jeweils umfasst:

einen Sender (5, 18);
einen Empfänger (6, 17); und einen mit einem Ausgang des jeweiligen Empfängers verbundenen Ladungs-Spannungs-Wandler (7).

9. Vorrichtung nach Anspruch 8, wobei der Sender (5, 18) ein optischer Infrarot-Gallium-Aluminium-Arsenid-Sender ist, der Energie bei einer Wellenlänge, die im Wesentlichen 890 nm gleich ist, abstrahlt, und der Empfänger (6, 17) ein optischer Infrarot-Empfänger in Form einer Silizium-PIN-Fotodiode mit einem Ansprechen im Bereich von 750 bis 1100 nm ist.

10. Verfahren zum Kompensieren eines Differentialfehlers zwischen einer Vielzahl von Körperoberflächensensoren, wobei jeder Sensor jeweils einen Sender und einen Empfänger umfasst, welches Verfahren die folgenden Schritte umfasst:

Hinzufügen eines amplitudenmodulierten Signals zu einem gesendeten Signal, das jeweils von jedem der Sender gesendet wird, wobei das amplitudenmodulierte Signal eine Frequenz aufweist, die:

(i) größer als eine Höchstfrequenz eines physiologischen Signals eines menschlichen oder tierischen Patienten ist, an den die Vielzahl von Körperoberflächensensoren angewendet wird; und

(ii) kleiner als eine Grenzfrequenz eines Anti-Aliasing-Tiefpassfilters einer Vorrichtung zur Verarbeitung eines empfangenen Signals ist, das jeweils von jedem der Empfänger empfangen wird;

Anwenden eines Bandpassfilters zum Zurückgewinnen des amplitudenmodulierten Signals

von einer Vielzahl der empfangenen Signale zum Bereitstellen einer jeweiligen Vielzahl von Kompensationssignalen;

Vergleichen der jeweiligen Amplituden der jeweiligen Vielzahl von Kompensationssignalen miteinander; und

Einstellen der Amplitude von mindestens einem der jeweiligen empfangenen Signale, bis die Amplituden der jeweiligen Vielzahl von Kompensationssignalen im Wesentlichen einander gleich sind.

11. Verfahren nach Anspruch 10, wobei die Frequenz des amplitudenmodulierten Signals größer als eine zweite harmonische Oberschwingung eines Herzschlages des menschlichen oder tierischen Patienten ist.

12. Verfahren nach Anspruch 10 oder Anspruch 11, wobei die Frequenz des amplitudenmodulierten Signals von 3 bis 7 Hz, bevorzugt von 4 bis 6 Hz, und am meisten bevorzugt im Wesentlichen gleich 5 Hz ist.

Revendications

1. Dispositif pour compenser une erreur différentielle entre une pluralité de capteurs de surface corporelle pour acquérir des signaux physiologiques respectifs d'un patient humain ou animal, chacun de ces capteurs comprenant respectivement un émetteur, un récepteur, et étant connecté à une sortie du récepteur respectif, un convertisseur de charge en tension, le dispositif comprenant :

un générateur de signal de synchronisation (2, 21) comprenant un oscillateur (1), pour générer un signal de synchronisation ;

un canal pour chaque capteur de surface corporelle respectif, chaque canal comprenant :

(i) un modulateur de courant (3) pour recevoir ledit signal de synchronisation et fournir un signal de commande de courant temporisé par ledit signal de synchronisation à l'émetteur du capteur de surface corporelle respectif ;

(ii) un récepteur synchrone (8) pour recevoir ledit signal de synchronisation du générateur de signal de synchronisation (2, 21) et un signal de sortie temporisé par ledit signal de synchronisation du convertisseur de charge en tension (7) du capteur de surface corporelle respectif et fournir un signal de sortie à large bande ;

(iii) un filtre passe-haut analogique (9) pour recevoir le signal de sortie à large bande du

récepteur synchrone (8) et fournir un signal de sortie filtré ; et
 (iv) un filtre passe-bas analogique d'anti-repliement (10) pour recevoir le signal de sortie filtré provenant du filtre passe-haut (9) et fournir un signal de sortie d'anti-repliement ;

le dispositif comprenant en outre :

- un convertisseur analogique-numérique (11) pour recevoir le signal de sortie d'anti-repliement provenant des canaux respectifs de chaque capteur de surface corporelle respectif et fournir un signal de sortie numérique pour un traitement de signal aval ;
 dans lequel le générateur de signal de synchronisation (2, 21) génère également une représentation numérique d'une onde sinusoïdale et comprend un convertisseur numérique-analogique (22) pour recevoir la représentation sinusoïdale numérique à un débit de mise à jour supérieur à la fréquence du signal de synchronisation et la convertir en une onde sinusoïdale analogique ayant une fréquence supérieure à la fréquence la plus élevée des signaux physiologiques et inférieure à une fréquence de coupure du filtre passe-bas anti-repliement (10) ;
 un filtre passe-bas (23) pour recevoir l'onde sinusoïdale analogique du convertisseur numérique-analogique (22) et en retirer les composantes de débit de mise à jour pour fournir une onde sinusoïdale propre ; et
 un modulateur d'amplitude (24) pour recevoir l'onde sinusoïdale propre du filtre passe-bas (23) et l'ajouter au signal de synchronisation.
2. Dispositif selon la revendication 1, dans lequel l'oscillateur (1) est un cristal d'une fréquence naturelle essentiellement égale à 4 MHz.
 3. Dispositif selon la revendication 1 ou la revendication 2, dans lequel le générateur de signal de synchronisation (2, 21) génère un signal de synchronisation avec une fréquence de 500 à 1500 Hz, de préférence de 750 à 1250 Hz, et le plus préférablement essentiellement égale à 1 kHz.
 4. Dispositif selon l'une quelconque des revendications précédentes, dans lequel le filtre passe-haut analogique (9) est un filtre Sallen-Key à deux pôles fournissant -3dB à environ 0,07 Hz.
 5. Dispositif selon l'une quelconque des revendications précédentes, dans lequel le filtre passe-bas analogique d'anti-repliement (10) est un filtre Sallen-Key à deux pôles fournissant -3dB à environ 6 Hz.

6. Dispositif selon l'une quelconque des revendications précédentes, dans lequel le débit de mise à jour est essentiellement égal à 20,48 kHz.
7. Dispositif selon l'une quelconque des revendications précédentes, dans lequel le filtre passe-bas (23) est un filtre R-C unipolaire fournissant -3 dB à environ 20 Hz.
8. Dispositif selon l'une quelconque des revendications précédentes, comprenant en outre une pluralité de capteurs de surface corporelle (15), chacun de ces capteurs comprenant respectivement :
 - un émetteur (5, 18) ;
 - un récepteur (6, 17) ; et, connecté à une sortie du récepteur respectif,
 - un convertisseur de charge en tension (7).
9. Dispositif selon la revendication 8, l'émetteur (5, 18) est un émetteur optique infrarouge en arséniure de gallium et aluminium émettant de l'énergie à une longueur d'onde essentiellement égale à 890 nm, et le récepteur (6, 17) est un récepteur optique infrarouge dans la forme d'une photodiode PIN en silicium avec une réponse dans la plage de 750 à 1100 nm.
10. Procédé de compensation d'une erreur différentielle entre une pluralité de capteurs de surface corporelle, chaque capteur comprenant respectivement un émetteur et un récepteur, le procédé comprenant les étapes consistant à :
 - ajouter un signal modulé en amplitude à un signal transmis respectivement transmis par chacun desdits émetteurs, le signal modulé en amplitude ayant une fréquence :
 - (i) supérieure à la fréquence la plus élevée d'un signal physiologique d'un patient humain ou animal auquel la pluralité de capteurs de surface corporelle est appliquée ; et
 - (ii) inférieure à une fréquence de coupure d'un filtre passe-bas anti-repliement d'un dispositif pour traiter un signal reçu respectivement reçu par chacun desdits récepteurs ;
 - appliquer un filtre passe-bande pour récupérer le signal modulé en amplitude à partir d'une pluralité des signaux reçus pour fournir une pluralité respective de signaux de compensation ;
 - comparer les amplitudes respectives de la pluralité respective de signaux de compensation entre eux ; et
 - ajuster l'amplitude d'au moins l'un des signaux reçus respectifs jusqu'à ce que les amplitudes

de la pluralité respective de signaux de compensation soient essentiellement égales entre elles.

11. Procédé selon la revendication 10, dans lequel la fréquence du signal modulé en amplitude est supérieure à une deuxième harmonique d'un battement de coeur du patient humain ou animal. 5
12. Procédé selon la revendication 10 ou la revendication 11, dans lequel la fréquence du signal modulé en amplitude est de 3 à 7 Hz, de préférence de 4 à 6 Hz, et le plus préférablement essentiellement égale à 5 Hz. 10

15

20

25

30

35

40

45

50

55

Fig. 1

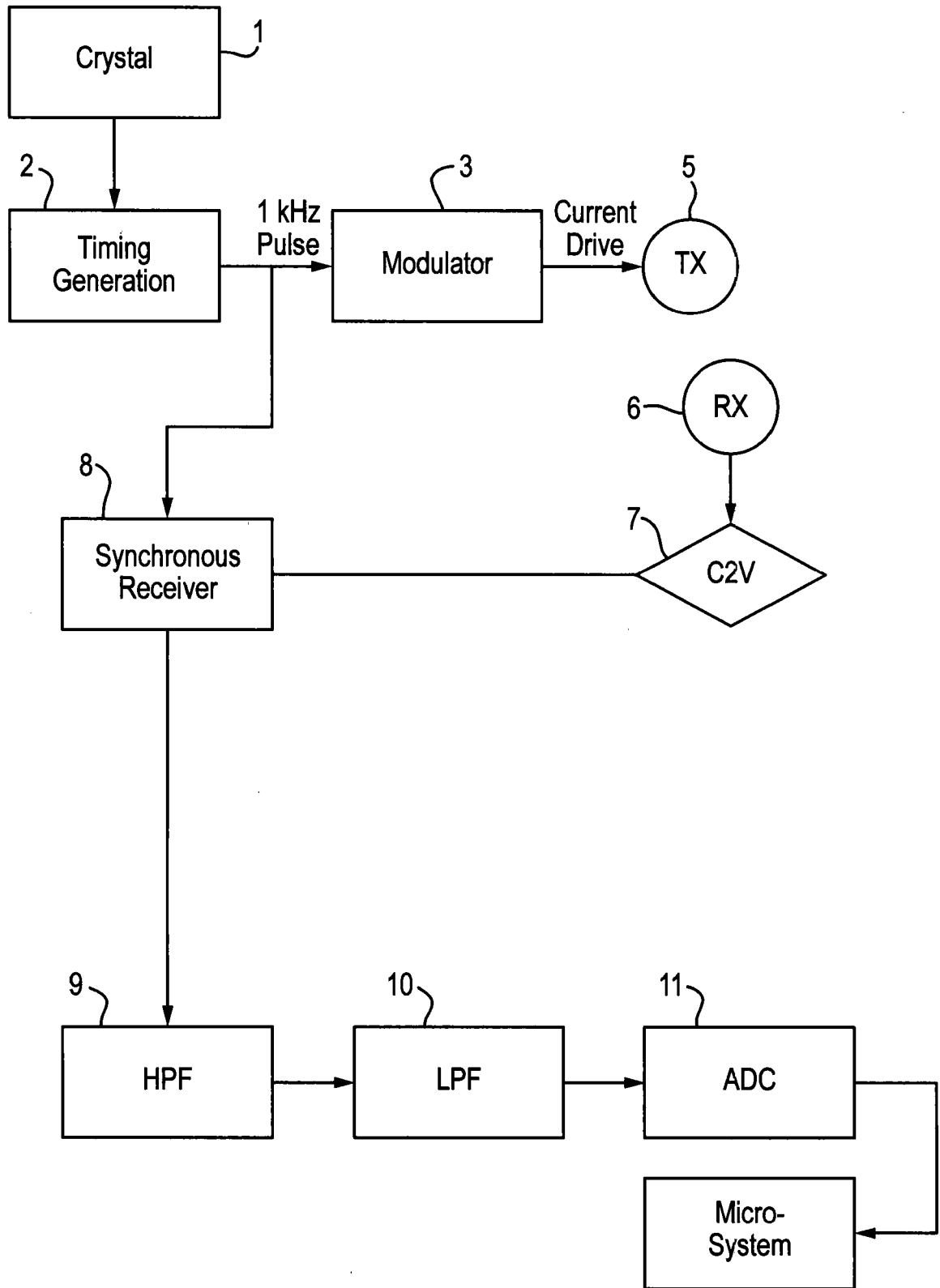

Fig. 2

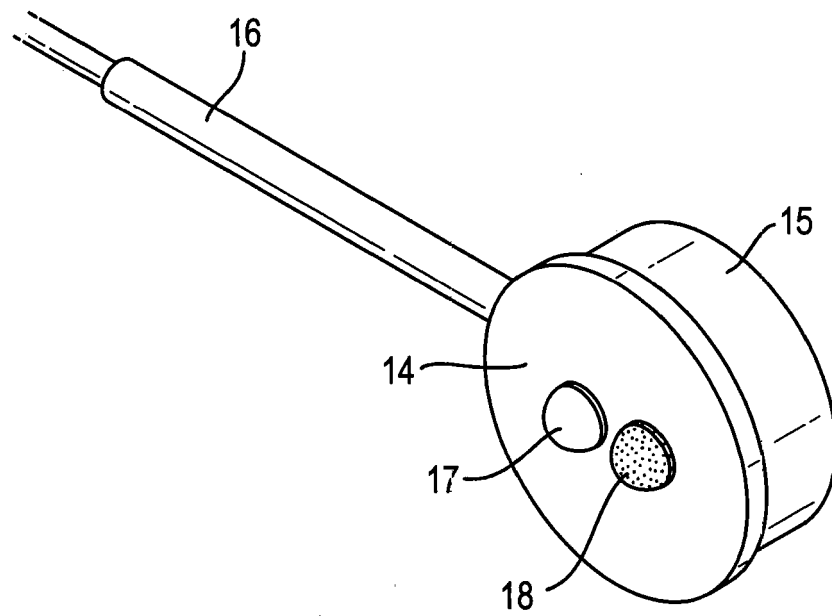

Fig. 3

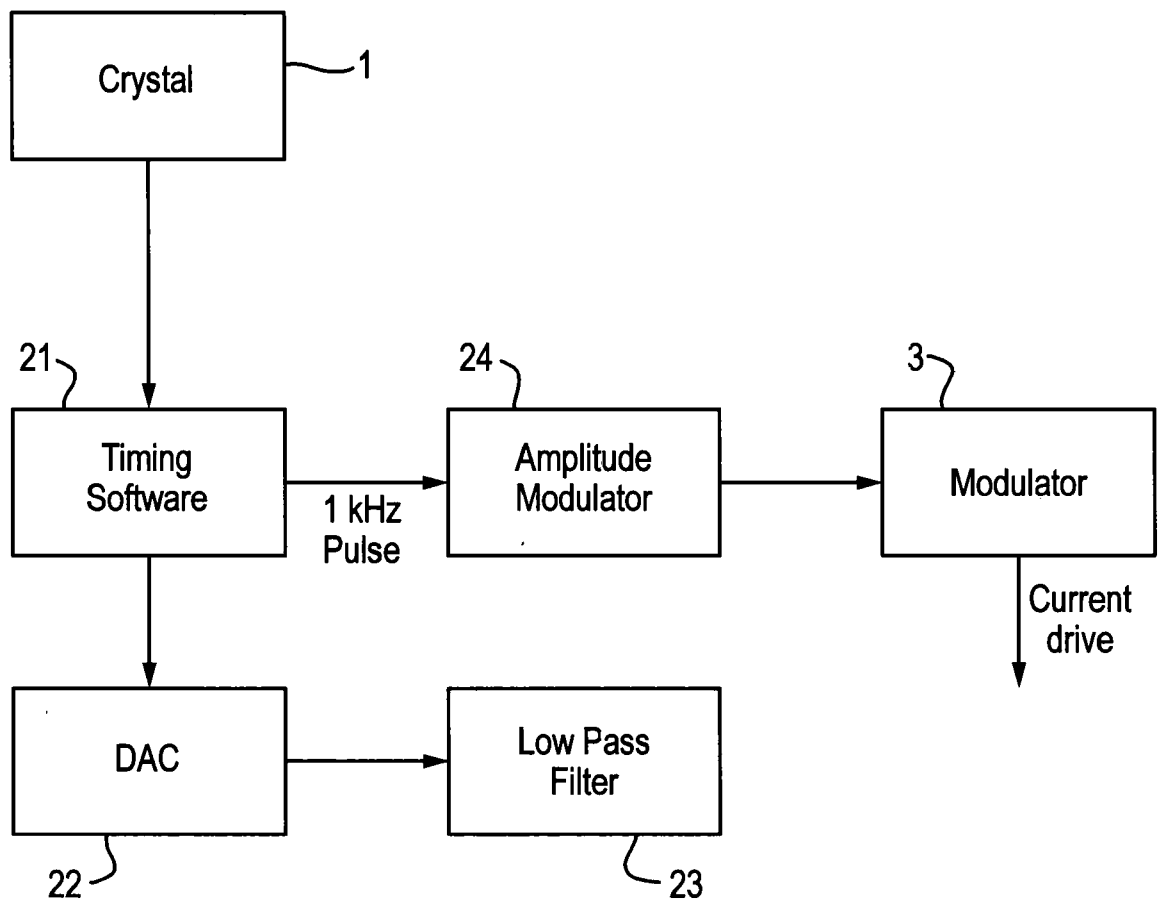
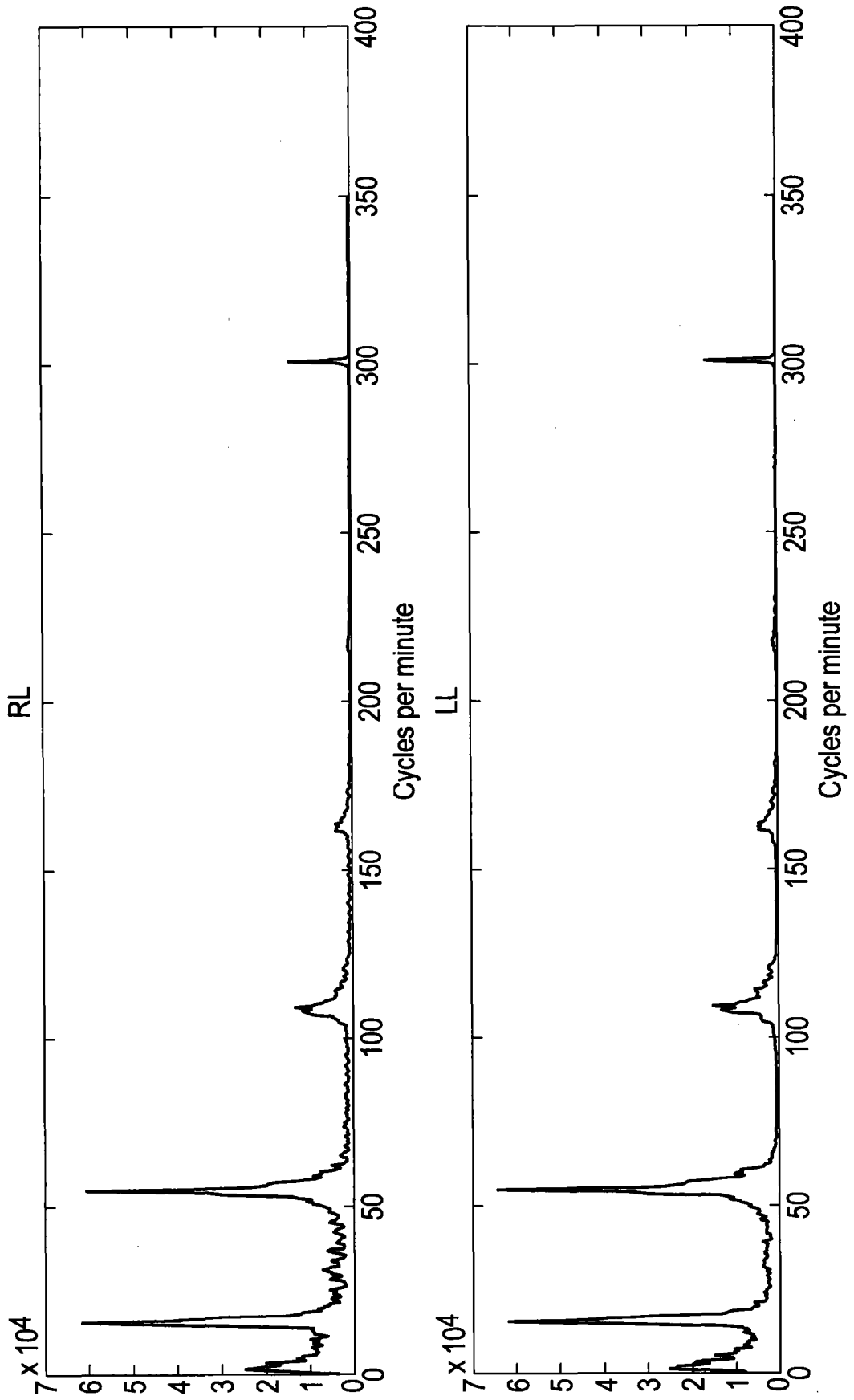

Fig. 4



REFERENCES CITED IN THE DESCRIPTION

This list of references cited by the applicant is for the reader's convenience only. It does not form part of the European patent document. Even though great care has been taken in compiling the references, errors or omissions cannot be excluded and the EPO disclaims all liability in this regard.

Patent documents cited in the description

- GB 2419403 A [0009]

专利名称(译)	组织变异性补偿装置和方法		
公开(公告)号	EP3148410B1	公开(公告)日	2018-03-21
申请号	EP2015729556	申请日	2015-05-29
申请(专利权)人(译)	HUNTLEIGH科技有限公司		
当前申请(专利权)人(译)	HUNTLEIGH科技有限公司		
[标]发明人	COOK STEPHEN JOHN BAILLY GREG MORRIS PHILIP GOUGH NIGEL		
发明人	COOK, STEPHEN JOHN BAILLY, GREG MORRIS, PHILIP GOUGH, NIGEL		
IPC分类号	A61B5/00 A61B5/02 A61B5/1455 A61B5/1495		
优先权	2014009599 2014-05-30 GB		
其他公开文献	EP3148410A1		
外部链接	Espacenet		

摘要(译)

一种补偿多个体表传感器之间的差分误差的方法和装置，其中每个传感器分别包括发射器和接收器。

