



(11) **EP 2 849 631 B1**

(12) **EUROPEAN PATENT SPECIFICATION**

(45) Date of publication and mention of the grant of the patent:
01.01.2020 Bulletin 2020/01

(51) Int Cl.:
A61B 6/03 (2006.01) G06T 7/00 (2017.01)
A61B 5/00 (2006.01) A61B 6/00 (2006.01)
A61B 5/02 (2006.01)

(21) Application number: **13735068.2**

(86) International application number:
PCT/IB2013/053801

(22) Date of filing: **10.05.2013**

(87) International publication number:
WO 2013/171644 (21.11.2013 Gazette 2013/47)

(54) **DETERMINATION OF A FRACTIONAL FLOW RESERVE (FFR) VALUE FOR A STENOSIS OF A VESSEL**

BESTIMMUNG EINES FRAKTIONELLE-FLUSSRESERVE (FRR)-WERTES FÜR EINE STENOSE EINES GEFÄSSES

DÉTERMINATION DE VALEUR DE RÉSERVE DE DÉBIT FRACTIONNAIRE (FFR) POUR STÉNOSE DE VAISSEAU

(84) Designated Contracting States:
AL AT BE BG CH CY CZ DE DK EE ES FI FR GB GR HR HU IE IS IT LI LT LU LV MC MK MT NL NO PL PT RO RS SE SI SK SM TR

(74) Representative: **Philips Intellectual Property & Standards**
High Tech Campus 5
5656 AE Eindhoven (NL)

(30) Priority: **14.05.2012 US 201261646525 P**

(56) References cited:
EP-A1- 1 967 140 US-A1- 2012 041 318

(43) Date of publication of application:
25.03.2015 Bulletin 2015/13

(73) Proprietors:
• **Koninklijke Philips N.V.**
5656 AE Eindhoven (NL)
Designated Contracting States:
AL AT BE BG CH CY CZ DK EE ES FI FR GB GR HR HU IE IS IT LI LT LU LV MC MK MT NL NO PL PT RO RS SE SI SK SM TR
• **Philips GmbH**
20099 Hamburg (DE)
Designated Contracting States:
DE

- **KRISTENSEN T S ET AL: "Correlation between coronary computed tomographic angiography and fractional flow reserve", INTERNATIONAL JOURNAL OF CARDIOLOGY, ELSEVIER SCIENCE PUBLISHERS, AMSTERDAM, NL, vol. 144, no. 2, 8 October 2010 (2010-10-08), pages 200-205, XP027409075, ISSN: 0167-5273 [retrieved on 2009-05-09]**
- **BON-KWON KOO ET AL: "Diagnosis of Ischemia-Causing Coronary Stenoses by Noninvasive Fractional Flow Reserve Computed From Coronary Computed Tomographic Angiograms", JOURNAL OF THE AMERICAN COLLEGE OF CARDIOLOGY, ELSEVIER, NEW YORK, NY, US, vol. 58, no. 19, 27 June 2011 (2011-06-27), pages 1989-1997, XP028326504, ISSN: 0735-1097, DOI: 10.1016/J.JACC.2011.06.066 [retrieved on 2011-09-22]**

(72) Inventors:
• **SCHMITT, Holger**
NL-5656 AE Eindhoven (NL)
• **FORTHMANN, Peter**
NL-5656 AE Eindhoven (NL)
• **GRASS, Michael**
NL-5656 AE Eindhoven (NL)

Note: Within nine months of the publication of the mention of the grant of the European patent in the European Patent Bulletin, any person may give notice to the European Patent Office of opposition to that patent, in accordance with the Implementing Regulations. Notice of opposition shall not be deemed to have been filed until the opposition fee has been paid. (Art. 99(1) European Patent Convention).

EP 2 849 631 B1

- **TONINO PIM A L ET AL: "Angiographic Versus Functional Severity of Coronary Artery Stenoses in the FAME Study Fractional Flow Reserve Versus Angiography in Multivessel Evaluation", JOURNAL OF THE AMERICAN COLLEGE OF CARDIOLOGY, vol. 55, no. 25, 1 January 2010 (2010-01-01), pages 2816-2821, XP029648797, ISSN: 0735-1097, DOI: 10.1016/J.JACC.2009.11.096**

Description

[0001] The following generally relates to determining a fractional flow reserve value for a stenosis in a vessel based on image data and a pre-defined stenosis characteristic to fractional flow reserve value look up table and is described with particular application to computed tomography (CT). However, the following is also amenable to other imaging modalities such as other modalities that produce three-dimensional (3D) angiography image data, including, but not limited to 3D rotational X-ray, 2D angiographic X-ray, magnetic resonance imaging (MRI), etc., and/or other imaging modalities.

[0002] A fractional flow reserve (FFR) value is a measurement of a pressure difference value across vessel stenosis, and the FFR value has been used to determine the likelihood that the stenosis impedes oxygen delivery to the heart muscle. Generally, an FFR value expresses the maximal flow down a vessel in the presence of a stenosis compared to the maximal flow in the hypothetical absence of the stenosis. The literature purports that the FFR value is based on an assumption that a pressure drop caused by a stenosis is indicative of a hemodynamic severity of the stenosis. As such, the FFR value is an important factor in the planning of percutaneous coronary interventions, e.g. stent placement.

[0003] Traditionally, an FFR value is measured invasively using a pressure wire to obtain the blood pressure before and after the stenosis. For a coronary FFR value, during coronary catheterization, a catheter is inserted into the femoral or radial arteries using a sheath and guide wire. A sensor affixed to the tip is positioned at the stenosis of interest, and the pressures are recorded across the stenosis during conditions promoted by various agents that effect vessel geometry, compliance and resistance, and/or other characteristics. The pressure value is an absolute number. The literature indicates that there is no absolute cut-off point at which FFR becomes abnormal; rather, there is a smooth transition, with a large grey zone of insecurity, with lower values indicating a more significant stenosis.

[0004] Unfortunately, the pressure wire used with this approach can be relatively expensive, and each invasive procedure poses a health risk to the patient. Approaches for non-invasive measurement of an FFR value also exist. Such approaches have included a patient specific computer simulation based on image data from a coronary CT angiography scan of the patient and geometric artery model derived from the image data. However, such simulations have been based on computational fluid dynamics (CFD) and are rather time-consuming. Currently, the cardiologist has to submit a CTA data set to an external institution and receives back the results hours later (e.g., 5 hours), which is cumbersome for the patient and the clinical workflow.

[0005] The aim of the study underlying that "Correlation between coronary computed tomographic angiography and fractional flow reserve" by T. S. Kristensen et

al., International Journal of Cardiology, volume 144, pages 200 to 205 (2010) was to compare Coronary CT angiography (CCTA) with fractional flow reserve (FFR) and it is demonstrated that quantitative CCTA is correlated to FFR. Using their CCTA criteria of abnormality, significant coronary artery stenoses can be ruled out with a high negative predictive value.

[0006] The aim of the study underlying "Diagnosis of Ischemia-Causing Coronary Stenoses by Noninvasive Fractional Flow Reserve Computed From Coronary Computed Tomographic Angiograms" by BK. Koo et al., Journal of the American College of Cardiology, volume 58, no. 19, 2011, pages 1989 to 1997 (2011) was to determine the diagnostic performance of a new method for quantifying fractional flow reserve (FFR) with computational fluid dynamics (CFD) applied to coronary computed tomography angiography (CCTA) data in patients with suspected or known coronary artery disease (CAD). Computation of FFR from CCTA data was performed on 159 vessels in 103 patients undergoing CCTA, invasive coronary angiography, and FFR. Independent core laboratories determined FFR_{CT} and CAD stenosis severity by CCTA. Ischemia was defined by an FFR_{CT} and $FFR \leq 0.80$, and anatomically obstructive CAD was defined as a CCTA with stenosis $\geq 50\%$. Diagnostic performance of FFR_{CT} and CCTA stenosis was assessed with invasive FFR as the reference standard. The authors come to the conclusion that noninvasive FFR derived from CCTA is a method with high diagnostic performance for the detection and exclusion of coronary lesions that cause ischemia. In view of the foregoing, there is an unresolved need for other approaches for determining a FFR value for a stenosis of a vessel.

[0007] Publication entitled "Angiographic Versus Functional Severity of Coronary Artery Stenoses in the FAME Study Fractional Flow Reserve Versus Angiography in Multivessel Evaluation" by Pim A. L. Tonino et al., Journal of the American College of Cardiology, vol. 55, no. 25, 1 January 2010, pages 2816-2821, as well as US patent application US2012/041318 (A1) are also relevant documents for understanding the background of the invention.

[0008] Aspects described herein address the above-referenced problems and others. In one aspect, a method includes determining at least one characteristic about a stenosis in a vessel of a patient from image data of the stenosis, mapping the at least one characteristic to a pre-defined stenosis characteristic to fractional flow reserve value look up table, identify the fractional flow reserve value in the look up table corresponding to the at least one characteristic, and visually presenting the image data and the identified fractional flow reserve value.

[0009] In another aspect, a system includes memory storing a pre-defined stenosis characteristic to fractional flow reserve value look up table. The system further includes a metric determiner that maps at least one characteristic about a stenosis in a vessel of a patient, which is determined from image data of the stenosis, to a char-

acteristic in the look up table and identifies a fractional flow reserve value corresponding to the characteristic. The system further includes a display that visually presents the image data and the identified fractional flow reserve value.

[0010] In another aspect, a computer readable storage medium is encoded with computer readable instructions. The instructions, when executed by a processor, cause the processor to: determine a fractional flow reserve value for a patient based on a pre-defined stenosis characteristic to fractional flow reserve value look up table and at least one characteristic about a stenosis in a vessel of a patient, which is determined from image data of the stenosis.

[0011] The invention may take form in various components and arrangements of components, and in various steps and arrangements of steps. The drawings are only for purposes of illustrating the preferred embodiments and are not to be construed as limiting the invention.

FIGURE 1 schematically illustrates an imaging system in connection with a metric determiner configured to at least determine an FFR value for a stenosis of a vessel of a patient.

FIGURE 2 illustrates an example of the metric determiner in connection with a pre-defined stenosis characteristic to fractional flow reserve value look up table.

FIGURE 3 illustrates an example method for determining an FFR value for a stenosis of a vessel of a patient.

[0012] FIGURE 1 schematically illustrates an imaging system 100 such as a CT scanner. The imaging system 100 includes a generally stationary gantry 102 and a rotating gantry 104, which is rotatably supported by the stationary gantry 102 and rotates around an examination region 106 about a z-axis. A subject support 108, such as a couch, supports an object or subject in the examination region 106.

[0013] A radiation source 110, such as an x-ray tube, is rotatably supported by the rotating gantry 104, rotates with the rotating gantry 104, and emits radiation that traverses the examination region 106. A radiation sensitive detector array 112 subtends an angular arc opposite the radiation source 110 across the examination region 106. The radiation sensitive detector array 112 detects radiation traversing the examination region 106 and generates a signal indicative thereof for each detected photon.

[0014] A reconstructor 114 reconstructs the projection, generating volumetric image data indicative of a scanned portion of a subject or object located in the imaging region 106. A general-purpose computing system or computer serves as an operator console 116. The console 116 includes a human readable output device such as a monitor and an input device such as a keyboard, mouse, etc. Software resident on the console 116 allows the operator

to interact with and/or operate the scanner 100 via a graphical user interface (GUI) or otherwise.

[0015] A metric determiner 118 is configured to at least process image data representing vessels (e.g., coronary arteries, cerebral artery, etc.) and determine an FFR value for a stenosis at least one of the vessels. The metric determiner 118 may also determine one or more other metrics. The image data can be generated by the system 100, other CT imaging system, 3D rotational X-ray system, an MRI system, other imaging system that produce three-dimensional (3D) angiography image data, and/or other imaging system.

[0016] As described in greater detail below, in one non-limiting instance, the metric determiner 118 determines various stenosis characteristics from the image data and maps the characteristics values to an FFR value in a stenosis characteristic to FFR look up table 120 stored in memory 122, which may include a database, local and/or remote memory, and/or other form of data storage. The look up table 120, generally, can be pre-calculated, for example, once for all patients, a sub-group of particular patients, etc., using a synthetic software artery model(s) and includes a mapping for a pre-determined set of different length of stenosis and a pre-determined set of different diameters to FFR values. More than one look up table can be generated, and different look up tables may correspond to different types of patients.

[0017] Using the stenosis characteristic to FFR look up table 120, relative to sending CTA image data to an external institution for computational fluid dynamics (CFD), greatly reduces the effort to obtain an individual FFR value at least because instead of a full CFD simulation for each patient, only a smaller number geometric properties need to be determined and correlated to the look up table 120 to determine a FFR value. Examples of suitable characteristics for generating the look up table 120 and performing the determination include stenosis physical characteristics such as stenosis length, stenosis diameter, vessel curvature, distance of the stenosis to a branching point, etc., patient information such as blood pressure, patient age, vessel type, etc., and/or other information.

[0018] The metric determiner 118 can be implemented through at least one processor that executes at least one computer readable instruction stored in computer readable storage medium, such as physical memory or other non-transitory storage medium. The processor may also execute one or more computer readable instructions carried by a carrier wave, a signal or other transitory medium. The metric determiner 118, the memory 122, and/or the output device 124 may be part of a same apparatus (e.g., computing system) and/or different apparatuses. The illustrated metric determiner 118 can communicate with devices such as the console 116, output device 124 (e.g., a monitor, a filmer, portable memory, etc.), an input device (e.g., a keyboard, a mouse, etc.), and/or other device.

[0019] FIGURE 2 illustrates an example of the metric

determiner 118 and the stenosis characteristic to FFR value look up table 120.

[0020] In this example, the metric determiner 118 includes a stenosis identifier 202. The stenosis identifier 202 identifies one or more stenoses in the image data. This can be achieved through automated approaches with authorized personal approval, manual approaches based on authorized personal input, or a combination of automatic and manual approaches.

[0021] The metric determiner 118 further includes a stenosis length determiner 204 that determines a length of one or more of the identified stenoses. Likewise, this can be achieved through automated approaches with authorized personal approval, manual approaches based on authorized personal input, or a combination of automatic and manual approaches.

[0022] The metric determiner 118 further includes a stenosis diameter determiner 206 that determines diameters along the length of one or more of the identified stenoses and identifies a minimum, average and/or other diameter. Likewise, this can be achieved through automated approaches with authorized personal approval, manual approaches based on authorized personal input, or a combination of automatic and manual approaches.

[0023] Where 2D angiographic X-ray projections are available, one or more image based stenosis characteristic can be determined from a single or a multitude of 2D projections which are acquired under comparable imaging settings, such as, e.g. least foreshortening, maximum source detector distance, known angle, etc.

[0024] The metric determiner 118 further includes an FFR value determiner 208. In the illustrated embodiment, this includes mapping the determined length and minimum diameter of a stenosis to the stenosis characteristic to FFR value look up table 120 based on one or more matching algorithms 222. As shown, in this example, the stenosis characteristic to FFR value look up table 120 includes a 2D array of stenosis length and diameter entries 207, with entries with increasing length from entry 210 to entry 212 and decreasing diameter from the entry 212 to entry 214, and the greatest length and smallest diameter at entry 216. Other formats are also contemplated herein.

[0025] Each one of the entries 207 corresponds to a particular FFR value. The metric determiner 118 determines the closest or best match between the measured length and measured diameter and the length and diameter in the stenosis characteristic to FFR value look up table 120, and returns the corresponding FFR value as the FFR value for the stenosis in the image data. The value look up table 120 may or may not include the illustrated graphical representations, and can also return the corresponding graphical representation.

[0026] Where the measured length and/or the diameter do not match any particular entry 207, the matching algorithm(s) 222 can be employed. By way of example, in one instance, a matching algorithm may indicate that the metric determiner 118 should interpolate between

neighboring entries to derive entries where the measured data does not match any look up table entry. Extrapolation and/or other techniques can be used to match the measured length and/or the diameter and determine an FFR value.

[0027] Where multiple entries 207 are equally likely (e.g., they are the same distance away from the measured stenosis diameter and length) or within a pre-determined range, a matching algorithm may instruct the metric determiner 118 to calculate an average FFR value from the individual FFR values. The average can be a straight or weighted average. In another instance, a matching algorithm may instruct the metric determiner 118 to select multiple FFR values as candidate FFR values.

[0028] In another instance, a matching algorithm may instruct the metric determiner 118 to select one of multiple FFR values based on a rule or priority, for example, which weights one of the measured stenosis characteristics greater than the other(s) stenosis characteristics. For example, where stenosis diameter and stenosis length correspond to multiple different FFR values, the algorithm may indicate that the stenosis diameter has priority over stenosis length, which may facilitate instructing the metric determiner 118 with selecting between the FFR values.

[0029] The literature indicates that the length of a stenosis and its minimum diameter are the strongest determinants of abnormal FFR. However, other information such as vessel curvature, distance of the stenosis to branching points, blood pressure, patient age, vessel type, etc. can be included in the stenosis characteristic to FFR value look up table 120 and/or used by the metric determiner 118 to determine a FFR value from the stenosis characteristic to FFR value look up table 120. Where further information is included the stenosis characteristic to FFR value look up table 120, the table becomes an N-dimensional look up table.

[0030] Optionally, the FFR value determiner 208 can additionally use the type of the vessel of interest to facilitate determining the FFR value. For example, where the coronary artery is of interest, the vessel of interest can be identified as the right coronary artery, the left coronary artery, the left circumflex artery, etc. Other vessels are also contemplated herein. This identification can be determined automatically and/or manually, for example, by metric determiner 118 and/or other component. The FFR value determiner 208 can then map the identified of vessel with the type of vessel in the stenosis characteristic to FFR value look up table 120, and use this information in addition or in alternative to the information discussed herein to determine an FFR value.

[0031] The metric determiner 118 at least one of visually presents the FFR value and/or conveys the FFR value to another device. By way of example, in one instance, the metric determiner 118 visually presents the image data showing the stenosis and the FFR value via a monitor output device 124. In another instance, the metric determiner 118 conveys the FFR value to the console

116, which visually presents the image data showing the stenosis and the FFR value.

[0032] In another instance, the graphical representation shown in FIGURE 2 for a corresponding entry 207 is displayed in alternative or addition to the FFR value. In another instance, a color overlay in which each color represents a known degree of stenosis is displayed in alternative or addition to the FFR value and/or the graphical representation. In another embodiment, this information can be sent to a filmer, a printer, another computer, further processed, etc.

[0033] An optional recommender 218 recommends a course of action based on the FFR value and/or other information such as clinical information about the patient, patient history, other information derived from the image data, etc. In the illustrated embodiment, the recommender 218 recommends the course of action based on a set of pre-defined recommended actions 220. The optional recommender 218 generates a signal indicative of the recommended course of action, and conveys the signal to the console 116, the output device 124 and/or other apparatus.

[0034] It is to be appreciated that the stenosis characteristic to FFR value look up table 120 may be stored in formats other than a look up table.

[0035] FIGURE 3 illustrates an example method for determining an FFR value for a stenosis in a vessel of a patient based on characteristics of the stenosis determined from image data and a stenosis characteristic to FFR value look up table 120.

[0036] It is to be appreciated that the ordering of the acts is not limiting. As such, other orderings are contemplated herein. In addition, one or more acts may be omitted and/or one or more additional acts may be included.

[0037] At 302, a scan of a vessel is performed.

[0038] At 304, a stenosis of the vessel is identified.

[0039] At 306, at least one characteristic of the identified stenosis is determined based on the image data. Examples of characteristics include, but are not limited to, stenosis length, stenosis diameter, vessel curvature, distance of the stenosis to a branching points, vessel type, and/or other characteristics.

[0040] At 308, a pre-calculated stenosis characteristic to FFR value look up table is obtained. An example of a suitable stenosis characteristic to FFR value look up table is the stenosis characteristic to FFR value look up table 120 discussed herein.

[0041] At 310, the at least one characteristic is mapped to an FFR value in the pre-calculated stenosis characteristic to FFR value look up table.

[0042] At 314, optionally, a recommended course of action is generated and provided based on the FFR value.

[0043] The above may be implemented by way of computer readable instructions, encoded or embedded on computer readable storage medium, which, when executed by a computer processor(s), cause the processor(s) to carry out the described acts. Additionally or al-

ternatively, at least one of the computer readable instructions is carried by a signal, carrier wave or other transitory medium.

[0044] The invention has been described with reference to the preferred embodiments. Modifications and alterations may occur to others upon reading and understanding the preceding detailed description. The scope of protection is defined by the appended claims.

Claims

1. A method, comprising:

determining (306), by a metric determiner (118), at least one characteristic about a stenosis in a vessel of a patient from image data of the stenosis, the at least one characteristic being a geometric property;

pre-calculating a pre-defined stenosis characteristic to fractional flow reserve value look up table (120) for all or a sub-group of patients using a synthetic software artery model;

mapping (310), by the metric determiner (118), the at least one characteristic to a characteristic in the pre-defined stenosis characteristic to fractional flow reserve value look up table (120) stored in a memory (122);

identifying, by the metric determiner (118), the fractional flow reserve value in the look up table corresponding to the at least one characteristic; and

visually presenting (312), by an output device (124), the image data and the identified fractional flow reserve value.

2. The method of claim 1, wherein the look up table (120) includes an N-dimensional array (207) of entries (208, 210, 212, 214), and each entry (208, 210, 212, 214) maps the at least one characteristic to a different flow reserve value.

3. A system, comprising:

a memory (122), including a pre-defined stenosis characteristic to fractional flow reserve value look up table (120), wherein the look up table (120) is pre-calculated for all or a sub-group of patients using a synthetic software artery model; a metric determiner (118) configured to mapping at least one characteristic, being a geometric property, about a stenosis in a vessel of a patient, which is determined from image data of the stenosis, to a characteristic in the look up table; and the metric determiner (118) further being configured to identify a fractional flow reserve value corresponding to the characteristic; and

a display (116) configured to visually presenting the image data and the identified fractional flow reserve value.

4. The system of claim 3 or the method of claim 1, wherein the at least one characteristic includes a length of the stenosis and a diameter of the stenosis.
5. The system of any of claims 3 to 4 or the method of claim 1 or 4, wherein the at least one characteristic further includes one or more of a vessel curvature, a distance of the stenosis to a branching point or a vessel type.
6. The system of any of claims 3 to 5 or the method of claim 1, 4 or 5, wherein the at least one characteristic further includes at least one characteristic about the patient.
7. The system of any of claims 3 to 6, wherein the metric determiner interpolates between a plurality of neighboring entries (208, 210, 212, 214) in the look up table (120) where there is no direct match between the at least one characteristic and the entries in the look up table (120).
8. The system of any of claims 3 to 6, wherein the metric determiner selects a closest match in the look up table (120) where there is no direct match between the at least one characteristic and the entries (208, 210, 212, 214) in the look up table (120).
9. The system of any of claims 3 to 6, wherein the metric determiner averages a plurality of neighboring entries (208, 210, 212, 214) in the look up table (120) where there is no direct match between the at least one characteristic and the entries in the look up table (120).
10. The system of any of claims 3 to 6, wherein the at least one characteristic includes at least two characteristics, and the metric determiner weights the at least two characteristics differently for mapping.
11. The system of any of claims 3 to 10, wherein the image data is displayed with a color overlay that indicates a severity of the stenosis.
12. The system of any of claims 3 to 11, further comprising: a recommender (218) that generates a signal which indicates a recommended course of action based on the fractional flow reserve value.
13. A computer readable storage medium encoded with computer readable instructions, which, when executed by a processor, cause the processor to: determine a fractional flow reserve value for a patient

based on a pre-defined stenosis characteristic to fractional flow reserve value look up table pre-calculated for all or a sub-group of patients using a synthetic software artery model and at least one characteristic about a stenosis in a vessel of a patient, which is determined from image data of the stenosis, wherein the at least one characteristic about a stenosis is a geometric property.

Patentansprüche

1. Verfahren, umfassend:

Bestimmen (306), durch einen metrischen Bestimmer (118), mindestens eines Merkmals über eine Stenose in einem Gefäß eines Patienten aus Bilddaten der Stenose, wobei mindestens ein Merkmal eine geometrische Eigenschaft ist;
 Vorberechnen eines vordefinierten Stenose-Merkmal auf eine Übersichtstabelle (120) eines fraktionellen Flussreservewerts für alle oder eine Untergruppe von Patienten unter Verwendung eines synthetischen Software-Arterienmodells;
 Abbilden (310), durch den metrische Bestimmer (118), des mindestens einen Merkmals auf ein Merkmal in dem vordefinierten Stenose-Merkmal in der Übersichtstabelle (120) eines fraktionellen Flussreservewerts, die in einem Speicher (122) abgelegt ist;
 Identifizieren, durch den metrische Bestimmer (118), des fraktionellen Flussreservewerts in der Übersichtstabelle entsprechend dem mindestens einen Merkmal; und
 visuelles Präsentieren (312), durch eine Ausgabevorrichtung (124), der Bilddaten und des identifizierten fraktionellen Flussreservewerts.

2. Verfahren nach Anspruch 1, wobei die Übersichtstabelle (120) eine N-dimensionale Anordnung (207) von Einträgen (208, 210, 212, 214) beinhaltet, und jeder Eintrag (208, 210, 212, 214) das mindestens eine Merkmal auf einen unterschiedlichen Flussreservewert abbildet.

3. System, umfassend:

einen Speicher (122), der ein vordefiniertes Stenose-Merkmal in einer Übersichtstabelle (120) eines fraktionellen Flussreservewerts beinhaltet, wobei die Übersichtstabelle (120) für alle oder eine Untergruppe von Patienten unter Verwendung eines synthetischen Software-Arterienmodells vorberechnet wird;
 einen metrische Bestimmer (118), der zum Abbilden mindestens eines Merkmals, das eine ge-

- ometrische Eigenschaft ist, über eine Stenose in einem Gefäß eines Patienten, das aus Bilddaten der Stenose bestimmt wird, auf ein Merkmal in der Übersichtstabelle konfiguriert ist; und der metrische Bestimmer (118) weiter konfiguriert ist, um einen fraktionellen Flussreservewert entsprechend dem Merkmal zu identifizieren; und eine Anzeige (116), die konfiguriert ist, um die Bilddaten und den identifizierten fraktionellen Flussreservewert visuell zu präsentieren.
4. System nach Anspruch 3 oder Verfahren nach Anspruch 1, wobei das mindestens eine Merkmal eine Länge der Stenose und einen Durchmesser der Stenose beinhaltet. 5
 5. System nach einem der Ansprüche 3 bis 4 oder Verfahren nach Anspruch 1 oder 4, wobei das mindestens eine Merkmal weiter eines oder mehr einer Gefäßkrümmung, eines Abstands der Stenose zu einem Verzweigungspunkt oder eines Gefäß-Typs beinhaltet. 10
 6. System nach einem der Ansprüche 3 bis 5 oder Verfahren nach Anspruch 1, 4 oder 5, wobei das mindestens eine Merkmal weiter mindestens ein Merkmal über den Patienten beinhaltet. 15
 7. System nach einem der Ansprüche 3 bis 6, wobei der metrische Bestimmer zwischen einer Vielzahl von benachbarten Einträgen (208, 210, 212, 214) in der Übersichtstabelle (120) interpoliert, wo es keine direkte Übereinstimmung zwischen dem mindestens einen Merkmal und den Einträgen in der Übersichtstabelle (120) gibt. 20
 8. System nach einem der Ansprüche 3 bis 6, wobei der metrische Bestimmer eine engste Übereinstimmung in der Übersichtstabelle (120) auswählt, wobei es keine direkte Übereinstimmung zwischen dem mindestens einen Merkmal und den Einträgen (208, 210, 212, 214) in der Übersichtstabelle (120) gibt. 25
 9. System nach einem der Ansprüche 3 bis 6, wobei der metrische Bestimmer eine Vielzahl von benachbarten Einträgen (208, 210, 212, 214) in der Übersichtstabelle (120) mittelt, wo es keine direkte Übereinstimmung zwischen dem mindestens einen Merkmal und den Einträgen in der Übersichtstabelle (120) gibt. 30
 10. System nach einem der Ansprüche 3 bis 6, wobei das mindestens eine Merkmal mindestens zwei Merkmale beinhaltet und der metrische Bestimmer die mindestens zwei Merkmale für die Abbildung unterschiedlich gewichtet. 35
 11. System nach einem der Ansprüche 3 bis 10, wobei die Bilddaten mit einer Farbüberlagerung angezeigt werden, die auf einen Schweregrad der Stenose hinweist. 40
 12. System nach einem der Ansprüche 3 bis 11, weiter umfassend: einen Empfänger (218), der ein Signal erzeugt, das auf eine empfohlene Vorgehensweise basierend auf dem fraktionellen Flussreservewert hinweist. 45
 13. Computerlesbares Speichermedium, das mit computerlesbaren Anweisungen codiert ist, die, wenn sie von einem Prozessor ausgeführt werden, bewirken, dass der Prozessor: einen fraktionellen Flussreservewert für einen Patienten basierend auf einem vordefinierten Stenose-Merkmal für eine Übersichtstabelle eines fraktionellen Flussreservewerts bestimmt, der für alle oder eine Untergruppe von Patienten unter Verwendung eines synthetischen Software-Arterienmodells vorberechnet wird, und mindestens ein Merkmal über eine Stenose in einem Gefäß eines Patienten, das aus Bilddaten der Stenose bestimmt wird, wobei das mindestens eine Merkmal über eine Stenose eine geometrische Eigenschaft ist. 50

Revendications

1. Procédé comprenant :

la détermination (306), par un dispositif de détermination de mesure (118), d'au moins une caractéristique d'une sténose dans un vaisseau d'un patient à partir de données d'image de la sténose, la au moins une caractéristique étant une propriété géométrique ;
 le pré-calcul d'une caractéristique de sténose prédéfinie dans une table de consultation de valeurs de réserve de débit fractionnaire (120) pour tous les patients ou un sous-groupe de patients utilisant un modèle d'artère logicielle artificielle ;
 la mise en correspondance (310), par le dispositif de détermination de mesure (118), de là au moins une caractéristique avec une caractéristique dans la caractéristique de sténose prédéfinie dans la table de consultation de valeurs de réserve de débit fractionnaire (120) stockée dans une mémoire (122) ;
 l'identification, par le dispositif de détermination de mesure (118), la valeur de réserve de débit fractionnaire dans la table de consultation correspondant à la au moins une caractéristique ; et
 la présentation visuelle (312), par un dispositif de sortie (124), des données d'image et de la valeur de réserve de débit fractionnaire identi-

- fiée.
2. Procédé selon la revendication 1, dans lequel la table de consultation (120) inclut un ensemble en N dimensions (207) d'entrées (208, 210, 212, 214), et chaque entrée (208, 210, 212, 214) met en correspondance la au moins une caractéristique avec une valeur de réserve de débit différente. 5
 3. Système, comprenant : 10
 - une mémoire (122), comprenant une caractéristique de sténose prédéfinie dans une table de consultation de valeurs de réserve de débit fractionnaire (120), dans lequel la table de consultation (120) est pré-calculée pour tous les patients ou un sous-groupe de patients utilisant un modèle d'artère logicielle artificielle ;
 - un dispositif de détermination de mesure (118) configuré pour mettre en correspondance au moins une caractéristique, étant une propriété géométrique, d'une sténose dans un vaisseau d'un patient, qui est déterminée à partir de données d'image de la sténose, avec une caractéristique dans la table de consultation ; et
 - le dispositif de détermination de mesure (118) étant en outre configuré pour identifier une valeur de réserve de débit fractionnaire correspondant à la caractéristique ; et
 - un écran (116) configuré pour présenter visuellement les données d'image et la valeur de réserve de débit fractionnaire identifiée. 15 20
 4. Système selon la revendication 3 ou procédé selon la revendication 1, dans lequel la au moins une caractéristique comprend une longueur de la sténose et un diamètre de la sténose. 25
 5. Système selon l'une des revendications 3 ou 4 ou procédé selon la revendication 1 ou 4, dans lequel la au moins une caractéristique inclut en outre un ou plusieurs d'une courbure de vaisseau, d'une distance entre la sténose et un point de ramification ou d'un type de vaisseau. 30
 6. Système selon l'une quelconque des revendications 3 à 5 ou procédé selon la revendication 1, 4 ou 5, dans lequel la au moins une caractéristique inclut en outre au moins une caractéristique sur le patient. 35
 7. Système selon l'une quelconque des revendications 3 à 6, dans lequel le dispositif de détermination de mesure interpole une pluralité d'entrées voisines (208, 210, 212, 214) dans la table de consultation (120) lorsqu'il n'y a aucune correspondance directe entre la au moins une caractéristique et les entrées dans la table de consultation (120). 40 45 50 55
 8. Système selon l'une quelconque des revendications 3 à 6, dans lequel le dispositif de détermination de mesure sélectionne une correspondance la plus proche dans la table de consultation (120) lorsqu'il n'y a aucune correspondance directe entre la au moins une caractéristique et les entrées (208, 210, 212, 214) dans la table de consultation (120).
 9. Système selon l'une quelconque des revendications 3 à 6, dans lequel le dispositif de détermination de mesure calcule la moyenne d'une pluralité d'entrées voisines (208, 210, 212, 214) dans la table de consultation (120) lorsqu'il n'y a aucune correspondance directe entre la au moins une caractéristique et les entrées dans la table de consultation (120).
 10. Système selon l'une quelconque des revendications 3 à 6, dans lequel la au moins une caractéristique inclut au moins deux caractéristiques, et le dispositif de détermination de mesure pondère les au moins deux caractéristiques différemment pour la mise en correspondance.
 11. Système selon l'une quelconque des revendications 3 à 10, dans lequel les données d'image sont affichées avec une couche de couleur qui indique une sévérité de la sténose.
 12. Système selon l'une quelconque des revendications 3 à 11, comprenant en outre :
 - un dispositif de recommandation (218) qui génère un signal qui indique un plan d'action recommandé sur la base de la valeur de réserve de débit fractionnaire.
 13. Support de stockage lisible par ordinateur codé avec des instructions lisibles par ordinateur, qui lorsqu'il est exécuté par un processeur, amène le processeur à : déterminer une valeur de réserve de débit fractionnaire pour un patient sur la base d'une caractéristique de sténose prédéfinie dans une table de consultation de valeurs de réserve de débit fractionnaire précalculées pour tous les patients ou un sous-groupe de patients en utilisant un modèle d'artère logicielle artificielle et au moins une caractéristique sur une sténose dans un vaisseau d'un patient, qui est déterminée à partir de données d'image de la sténose, dans lequel la au moins une caractéristique sur une sténose est une propriété géométrique.

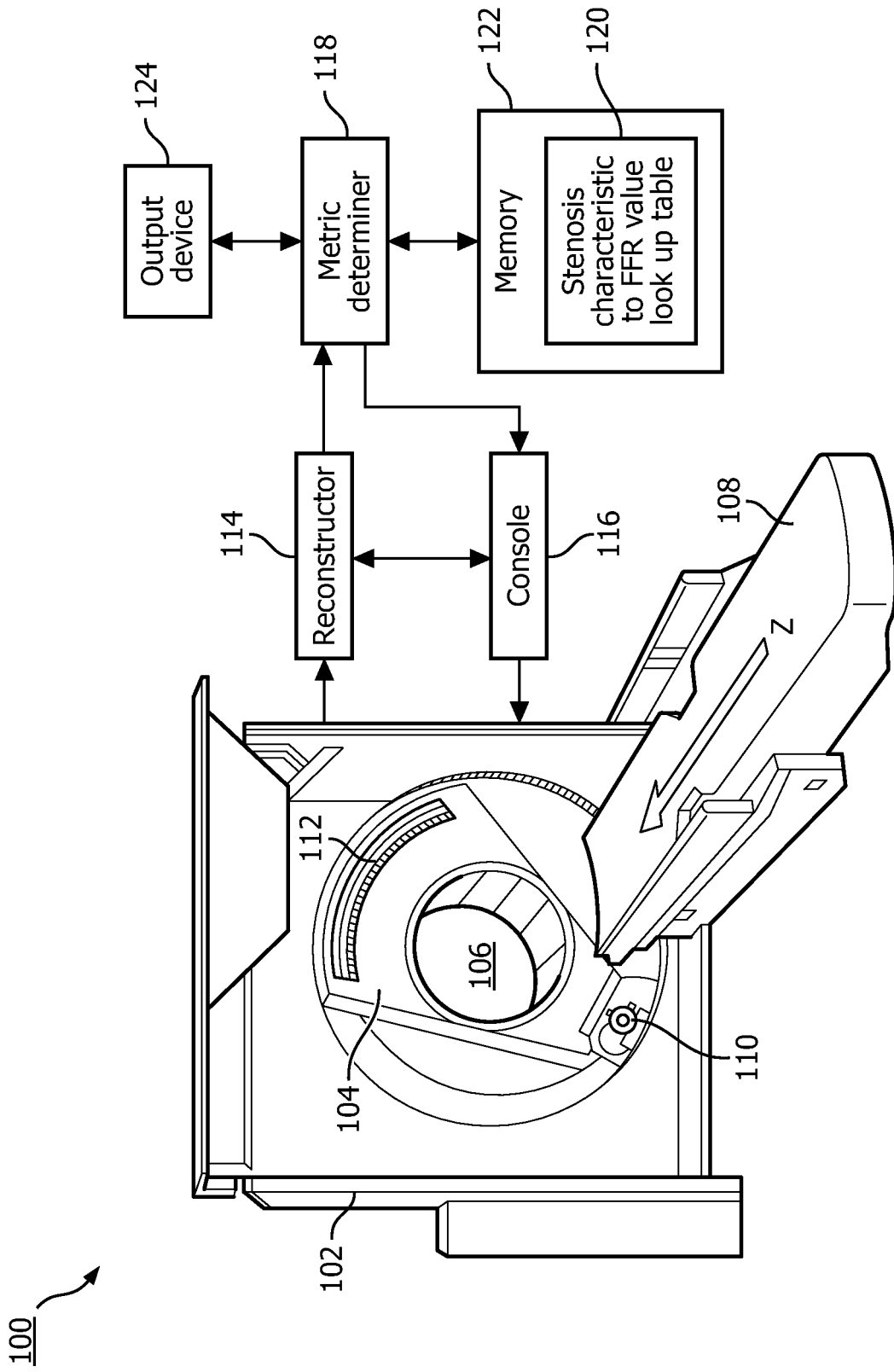

FIG. 1

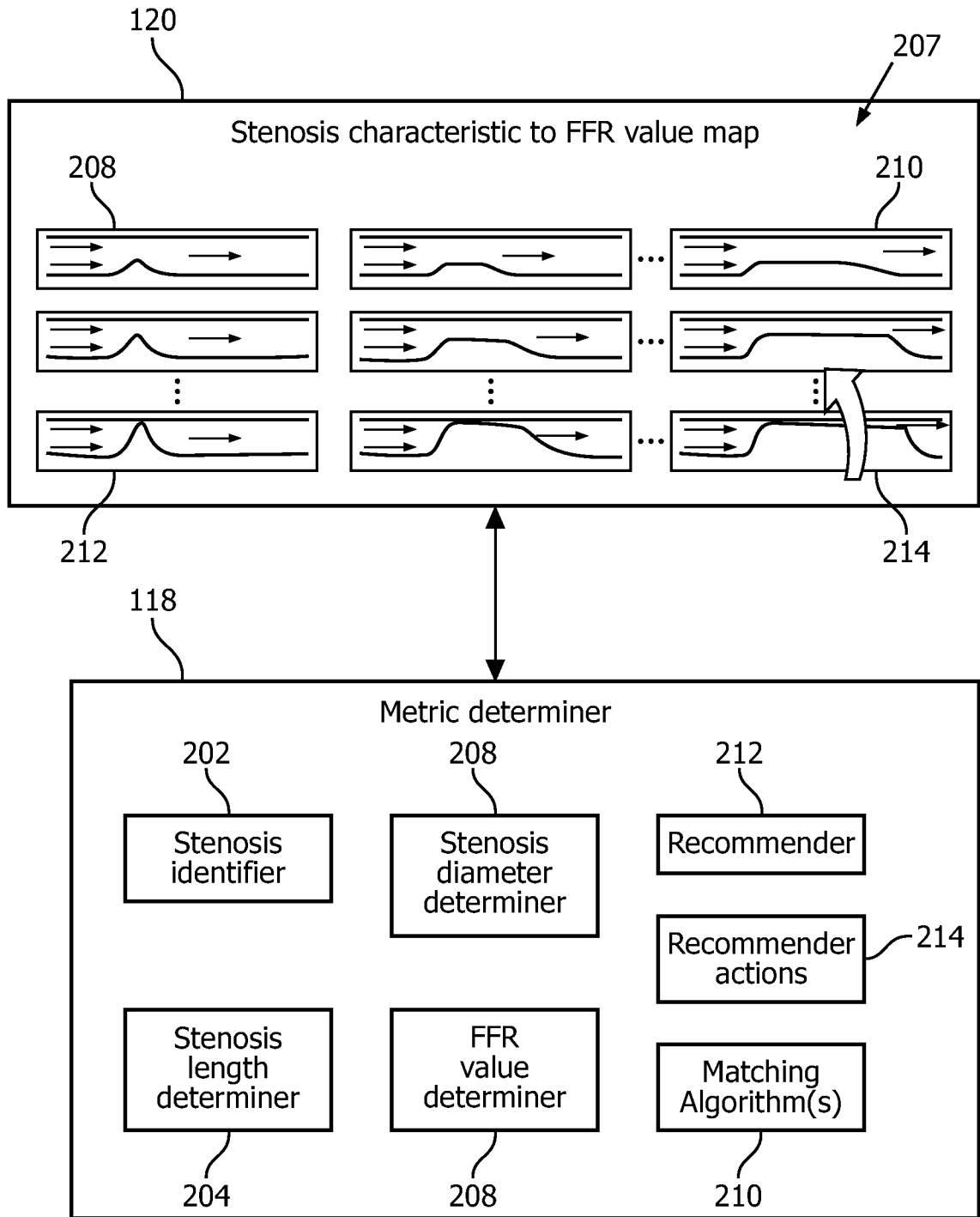

FIG. 2

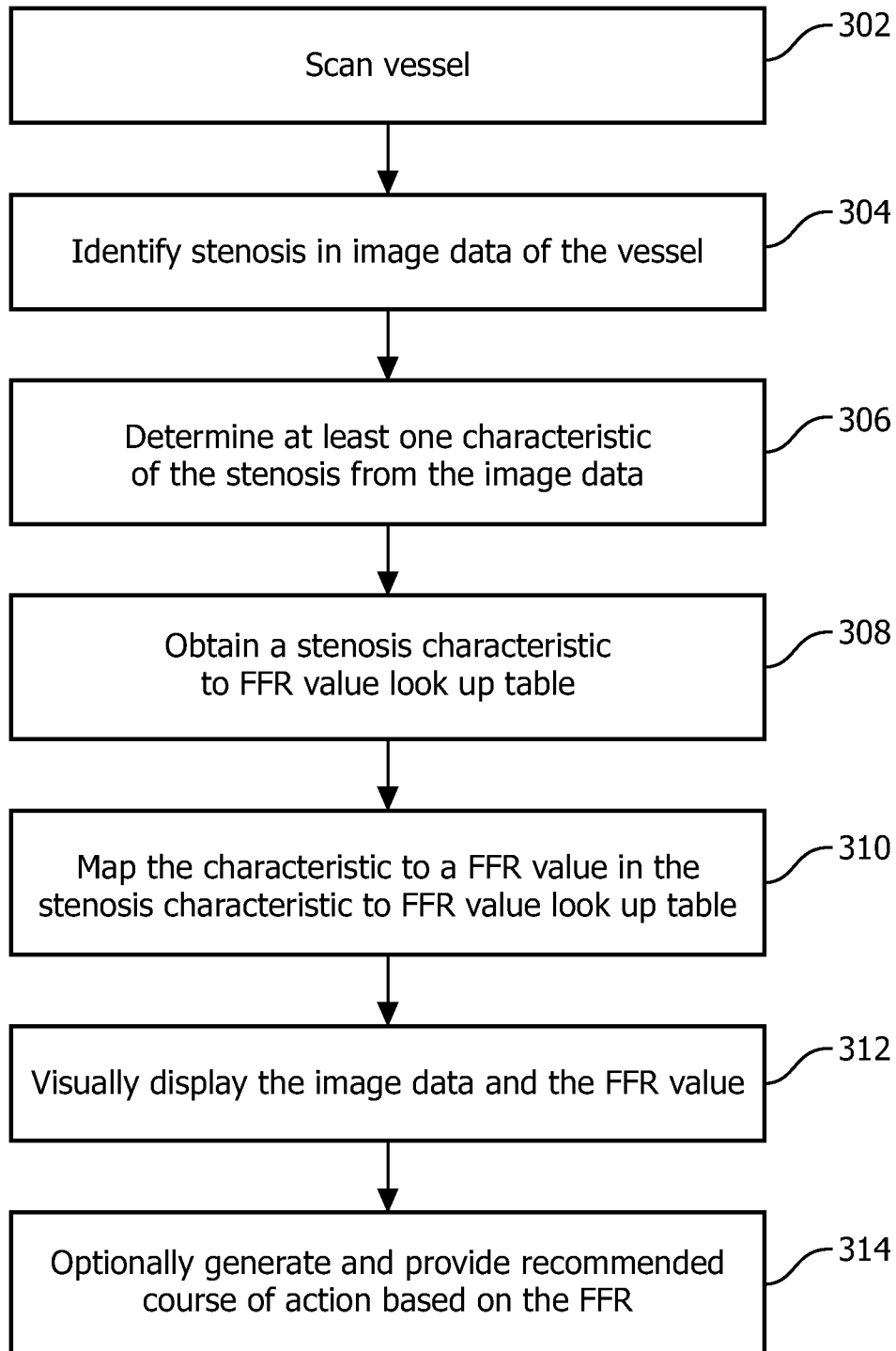

FIG. 3

REFERENCES CITED IN THE DESCRIPTION

This list of references cited by the applicant is for the reader's convenience only. It does not form part of the European patent document. Even though great care has been taken in compiling the references, errors or omissions cannot be excluded and the EPO disclaims all liability in this regard.

Patent documents cited in the description

- US 2012041318 A1 [0007]

Non-patent literature cited in the description

- **T. S. KRISTENSEN et al.** Correlation between coronary computed tomographic angiography and fractional flow reserve. *International Journal of Cardiology*, 2010, vol. 144, 200-205 [0005]
- **BK. KOO et al.** Diagnosis of Ischemia-Causing Coronary Stenoses by Noninvasive Fractional Flow Reserve Computed From Coronary Computed Tomographic Angiograms. *Journal of the American College of Cardiology*, 2011, vol. 58 (19), 1989-1997 [0006]
- **PIM A. L. TONINO et al.** Angiographic Versus Functional Severity of Coronary Artery Stenoses in the FAME Study Fractional Flow Reserve Versus Angiography in Multivessel Evaluation. *Journal of the American College of Cardiology*, 01 January 2010, vol. 55 (25), 2816-2821 [0007]

专利名称(译)	确定血管狭窄的分数流量储备 (FFR) 值		
公开(公告)号	EP2849631A1	公开(公告)日	2015-03-25
申请号	EP2013735068	申请日	2013-05-10
[标]申请(专利权)人(译)	皇家飞利浦电子股份有限公司		
申请(专利权)人(译)	皇家飞利浦N.V. PHILIPS GMBH		
当前申请(专利权)人(译)	皇家飞利浦N.V. PHILIPS GMBH		
[标]发明人	SCHMITT HOLGER FORTHMANN PETER GRASS MICHAEL		
发明人	SCHMITT, HOLGER FORTHMANN, PETER GRASS, MICHAEL		
IPC分类号	A61B5/00 A61B6/00 A61B5/02		
CPC分类号	A61B5/02007 A61B5/742 A61B6/032 A61B6/504 A61B6/5217 G01N2800/323 G06T7/0014 G06T2207/10088 G06T2207/10116 G06T2207/30104		
代理机构(译)	STEFFEN, THOMAS		
优先权	61/646525 2012-05-14 US		
其他公开文献	EP2849631B1		
外部链接	Espacenet		

摘要(译)

一种方法包括：从狭窄的图像数据确定关于患者血管中的狭窄的至少一个特征；将特征映射到预定义的狭窄特征到分数血流储备值查找表；在外观中识别分数血流储备值。对应特性的上表，并在视觉上呈现图像数据和识别出的分流储备值。一种系统，包括：存储器，该存储器存储预定的狭窄特征至分数流量储备值查找表；度量确定器 (118)，其映射关于患者血管中的狭窄的至少一个特征，其从所述血管的图像数据确定。狭窄，查找表中的特征并识别与该特征相对应的分数流量储备值，以及显示器 (116)，其在视觉上呈现图像数据和所识别的分数流量储备值。