



(11) **EP 2 777 411 B1**

(12) **EUROPEAN PATENT SPECIFICATION**

(45) Date of publication and mention of the grant of the patent:
12.10.2016 Bulletin 2016/41

(51) Int Cl.:
A41D 13/05 (2006.01) **A61B 5/021** (2006.01)
A63B 71/12 (2006.01) **A61B 17/12** (2006.01)
A61B 5/00 (2006.01)

(21) Application number: **13166318.9**

(22) Date of filing: **02.05.2013**

(54) **Devices to reduce the likelihood of injury from concussive or blast forces**

Vorrichtungen zur Reduzierung der Wahrscheinlichkeit von Verletzungen aus Erschütterungs- oder Sprengkräften

dispositifs pour réduire le risque de blessures suite à des forces concussives ou d'explosion

(84) Designated Contracting States:
AL AT BE BG CH CY CZ DE DK EE ES FI FR GB GR HR HU IE IS IT LI LT LU LV MC MK MT NL NO PL PT RO RS SE SI SK SM TR

(30) Priority: **15.03.2013 US 201313841195**

(43) Date of publication of application:
17.09.2014 Bulletin 2014/38

(73) Proprietor: **TBI Innovations, LLC**
Richmond, IN 47374 (US)

(72) Inventors:
• **Smith, David**
Richmond, IN 47374 (US)
• **Vititoe, Kevin John**
Westerville, OH 43082 (US)

• **Float, Jamison Joseph**
Galloway, OH 43119 (US)
• **Leeder, Chad Michael**
New Albany, NY 43054 (US)

(74) Representative: **Schiweck, Weinzierl & Koch**
European Patent Attorneys
Landsberger Straße 98
80339 München (DE)

(56) References cited:
WO-A1-2012/054262 WO-A1-2013/055409
US-A- 2 676 586 US-A1- 2005 262 618
US-A1- 2012 197 290 US-A1- 2013 041 303
US-B2- 8 381 362

EP 2 777 411 B1

Note: Within nine months of the publication of the mention of the grant of the European patent in the European Patent Bulletin, any person may give notice to the European Patent Office of opposition to that patent, in accordance with the Implementing Regulations. Notice of opposition shall not be deemed to have been filed until the opposition fee has been paid. (Art. 99(1) European Patent Convention).

Description

TECHNICAL FIELD

[0001] The present disclosure is generally related to a method and devices for reducing the effects of exposure to concussive events.

BACKGROUND OF THE INVENTION

[0002] Traumatic brain injury (TBI) continues to be one of the most common causes of death and morbidity in persons under age 45, even in western societies. A reported 1.7 million people suffer from TBI annually in the United States alone, resulting in an estimated per annum total cost of over \$60 billion. Historically, prevention of skull and brain injury has focused on the use of helmets as external cranial protection. This approach is fundamentally flawed as helmets have provided benefit for only major penetrating brain injuries and skull fractures. These occur in a very small fraction of head injuries in civilian sphere. Military statistics have shown that even on the battlefield, less than 0.5% of TBI is from a penetrating object. However, both military personnel and athletes are subjected to high velocity acceleration-deceleration mechanisms that are not mitigated by helmets and lead to concussive injury to the brain. In large part, the human brain's relative freedom of movement within the cranial cavity predisposes to both linear and rotational force vectors, with resultant energy absorption resulting in cellular disruption and dysfunction, sometimes with delayed cell death.

[0003] The skull and spinal canal contain only nervous tissue, connective tissue and fat cells and their interstitium, blood, and cerebrospinal fluid (CSF). The non-fluid contents do not completely fill the rigid container delimited by the skull and bony spinal canal, leaving a 'reserve volume' that is occupied by the fluid components. The change in volume inside a container for a given change in pressure is termed 'compliance'. Increases in volume of the contents of the skull and bony spinal canal, within the range of reserve volume, occur at low container pressures (due to the high compliance of the system). Acceleration or deceleration of the skull can result in a differential acceleration or deceleration between the skull and its contents when the brain and fluids collide with the inside of the skull. TBI may occur because of compression, stretching, or tearing of tissue and blood vessels as a result of the brain impacting the skull. Considering the semi-solid properties of the mammalian brain, this effect is referred to as "SLOSH".

[0004] While helmets are effective in preventing the infrequent penetration or fracture of the skull, they have little ability to limit SLOSH effects. Mitigating SLOSH by increasing the pressure of the fluid contents of the brain can significantly reduce the propensity for damage to the brain tissue or its blood vessels by reducing the compressibility of the brain. The reduction in compressibility

results in reduced absorption of kinetic, acoustic, thermal, and vibrational energy by the brain.

[0005] The same concussive events that produce TBI can also have damaging effects to the inner ear, spinal cord and structures of the eye. Sensory neural hearing loss is noted to occur at a rate of 85% in TBI. Concurrent injuries to the auditory system as a result of acute blast trauma and resultant traumatic brain injury accounted for one-quarter of all injuries among marines during Operation Iraqi Freedom through 2004 - the most common single injury type. Auditory dysfunction has become the most prevalent individual military service-connected disability, with compensation totaling more than \$1 billion annually.

[0006] Although one might expect blast waves to cause tympanic membrane rupture and ossicular disruption (thus resulting in *conductive* hearing loss), available audiology reports showed that *pure sensory neural loss* was the most prevalent type of hearing loss in patients. An observational study performed from 1999-2006 found that 58 percent of active-duty soldiers who complained of hearing loss were diagnosed with pure sensorineural loss. Data from this study revealed that 38 percent of the patients with blast related TBI also reported sensory neural tinnitus (ringing in the ears).

[0007] The sites for sensory neural hearing loss are the inner ear structures referred to as the cochlea and vestibular apparatus (semicircular canals). Both of these structures are fluid filled and therefore susceptible to SLOSH induced energy absorption. The tympanic and vestibular canals of the cochlea are also fluid filled and transmit pressure and fluid waves to the delicate hair cells of the organ of corti. The auditory hair cells react directly to the vibrations in the liquid in which they are immersed rather than to transverse vibrations in the cochlear duct. The cochlea and its associated hair cells are particularly susceptible to SLOSH energy absorption.

[0008] Approximately 30 ml (21 %) of a total CSF volume of 140 ml resides within the spinal axis, and about one-third of the compliance of the CSF system has been attributed to the spinal compartment. As in the brain, increasing the pressure of the CSF within the spinal compartment reduces the susceptibility of the spinal compartment to concussive injuries by increasing the elasticity of the contents of the spinal column, thereby reducing the amount of energy absorbed by the contents of the spinal column when subjected to a concussive force.

[0009] Of 207 severe eye injuries in a report of military casualties in Operation Iraq Freedom OIF, 82 percent were caused by blast and blast fragmentation. Eye injuries accounted for 13 percent (19/149) of all battlefield injuries seen at a combat support hospital during Operations Desert Shield and Desert Storm. Hyphema (blood within the anterior chamber) and traumatic cataract were the most common findings in closed globe injuries, the majority (67%) of eyes sustained orbital injury. Of the service members experiencing combat ocular trauma (COT) in Operation Enduring Freedom, 66 percent also

had TBI. Simply stated, roughly two-thirds of the combat related eye injuries were closed blast wave energy absorptions resulting in rupture.

[0010] Traumatic brain injury, or the concussive or blast-related events leading to TBI, has also been found to be a leading cause of anosmia (loss or impairment of olfactory function, i.e., sense of smell). Certain studies have reported that a large proportion of patients with post-traumatic anosmia exhibit abnormalities in the olfactory bulbs and in the inferior frontal lobes, suggesting in the latter case that reducing TBI can reduce the risk of anosmia. While loss or impairment of olfactory function can be more than a nuisance to humans, the same injury to Breecher dogs (e.g., bomb sniffers) can be catastrophic. Breecher dogs are inherently exposed to the risk of concussive events and their primary purpose is to help soldiers avoid such an event. Preventing or reducing the likelihood of TBI and associated loss of smell can be critical to the Breecher dog's mission.

[0011] Standard prophylactic measures designed to protect the brain against injury in the case of head trauma have hitherto included only various helmets. Helmets are primarily designed to protect the skull from penetrating injuries and fractures, but less so from pathological movements of the brain, exemplified by the classic cerebral concussion. Moreover, helmets have no meaningful effect on blast-related injuries to the ear, spinal column and eyes.

[0012] WO 2012/054262 A1 discloses a device to reduce SLOSH energy absorption in an animal or human subject by reducing the flow of one or more neck veins by compressing at least one of said vessels, wherein the device can comprise a collar configured to at least partially encircle the neck of an animal or human subject, and at least one region inwardly directed to contact the neck when encircled by the collar, thereby applying a localized pressure to a neck vein.

SUMMARY OF THE INVENTION

[0013] Intracranial injuries due to exposure to external concussive forces remains a devastating condition for which traditionally extra-cranial protection has been utilized in the form of helmets. Although headgear is effective in preventing the most devastating intracranial injuries, penetrating injuries, and skull fractures, it is limited in its ability to prevent concussions or damage to the structures within the cranium. In accordance with one disclosed method, the internal jugular vein (IJV) is mildly compressed to increase cerebral blood volume and decrease the intracranial compliance. This results in increased intercranial volume and resultant pressure and thus reduction of the differential acceleration between the skull and its contents when subjected to a concussive force. Reduction in the differential acceleration between the skull and its contents means a reduction in propensity for compression, stretching, or tearing of the brain or vascular tissues within the skull, leading to less energy ab-

sorption, and thus less traumatic axonal and glial injury. Mild restriction of flow of the IJV also leads to increased cochlear pressure to reduce risk of damage to the inner ear, increased pressure in the cerebrospinal fluid to reduce the risk of injury to the spinal column, and increased intraocular pressure to protect the internal structure of the eye from concussive events.

[0014] In an attempt to mitigate intracranial slosh it is recognized that the single intracranial compartment that is most amenable to rapid, reversible change in volume and pressure is the blood space. The simplest and most rapid means of increasing the volume blood compartment is to inhibit its outflow by mechanically restricting one or more of the draining veins in the neck.

[0015] One aspect of the disclosure, therefore, encompasses a method for reducing the likelihood of injury to a subject exposed to external concussive force, comprising: contacting one or more protuberances to the neck of the subject, wherein each protuberance is located above one or more neck veins of the subject; and applying an external pressure to the protuberances sufficient to restrict blood flow egressing from the head of the subject through the one or more neck veins. In said method, preferably a device of the present invention is applied.

Accordingly, in a preferred embodiment, a device is used (in a method) for reducing the likelihood of injury to a subject exposed to external concussive force, said method comprising: contacting one or protuberances of said device to the neck of the subject, wherein each protuberance is located above one or more neck veins of the subject; and applying an external pressure to the protuberances sufficient to restrict blood flow egressing from the head of the subject through the one or more neck veins. In some embodiment, the injury comprises one or more selected from the group consisting of traumatic brain injury, concussive injury to the spinal column, concussive injury to the inner ear, and concussive injury to the ocular or olfactory structures.

[0016] In some embodiments, the one or more veins in the neck of the subject comprises one or more of an interior or exterior jugular vein. In some related embodiments, restriction of the blood flow egressing from the head of the subject results in an increase in fluid volume and pressure in the intracranial cavity of the subject. The cranial volume is not fixed as the eyeballs and the tympanic membranes can slightly bulge outward (as in the jugular tympanic reflex), further the foramen or opening of the cranial vault are all able to accommodate a greater volume. In some embodiments, the external pressure applied to the one or more veins in the neck is equivalent to a fluid pressure of 5-25 mm Hg. In some embodiments, the external pressure applied to one or more veins in the neck is equivalent to at least 5, 10, 15, 20, 25, 30, 35, 40, 45, 50, 55, 60, 65, or 70 mm Hg and/or not more than 25, 30, 35, 40, 45, 50, 55, 60, 65, 70, 75, or 80 mm Hg.

[0017] Other aspects of this disclosure encompass devices that reduce the risk of traumatic brain injury from concussive events in an animal or human subject by re-

ducing the flow of one or more neck veins by compressing at least one of said veins. The devices of this aspect comprise at least one region (i.e., a protuberance) that is inwardly directed and contacts the neck of the wearer of the device, thereby applying a localized pressure to a neck vein. Accordingly, the device of the present invention is in another aspect for use (in a method) of reducing the risk of brain injury from concussive events in an animal or human subject by reducing the flow of one or more neck veins by compressing at least one of said veins. Also, the device of the present invention is for use in a method of mitigating or preventing traumatic brain injury (TBI).

[0018] Also disclosed herein is a non-claimed device which comprises a circumferential collar sized to encircle the neck of a subject; and one or more inwardly directed protuberances integral to the collar; wherein the protuberances are located on the collar such that they are disposed above one or more neck veins of the subject when the collar is encircling the neck of the subject; and wherein the collar is sized so as to exert sufficient pressure on the protuberances to restrict blood flow egressing from the head of the subject through the one or more neck veins.

[0019] The non-claimed circumferential collar is sized to be positioned between the collar bone and the cricoids cartilage of the subject.

[0020] The non-claimed collar defines a cut-out sized and positioned to provide clearance for the laryngeal prominence when the collar encircles the neck of the subject.

[0021] At least a portion of the non-claimed circumferential collar comprises an elastic material capable of stretching so as to increase the circumference of the collar. In some further examples, the collar further comprises a compression indicator associated with said elastic material configured to provide a visual indication of the elongation of said portion when encircling the neck of the subject.

[0022] The non-claimed circumferential collar comprises a rigid or semi-rigid portion defining a bridge spanning the laryngeal prominence.

[0023] The non-claimed circumferential collar comprises a flexible material strap and engagement elements at opposite ends of said strap configured to be releasably engaged so as to encircle the neck of the subject. In some further examples, the collar further comprises a rigid or semi-rigid portion defining a bridge spanning the laryngeal prominence, wherein the engagement elements at opposite ends of the strap are configured to be releasably engaged to corresponding ends of the rigid or semi-rigid laryngeal bridge. In some further examples, the flexible material strap comprises an elastic material capable of being stretched so as to increase the circumference of the collar.

[0024] The non-claimed circumferential collar further comprises one or more bladders disposed within the circumferential collar. In some further examples, at least

one of the bladders is disposed within the circumferential collar at a location other than above the protuberances. In some further examples, at least one of the bladders is disposed at a location above one or more of the protuberances. In some further examples, a protuberance is defined by the one or more bladders. In some further examples, at least one of the bladders contains a reversibly compressible foam material, and wherein the interior of the foam-containing bladder is in fluid communication with the exterior of the bladder via a pressure relief valve. In some further examples, the circumferential collar further comprises a pump element in fluid communication with a bladder, whereby the fill level of a bladder can be adjusted.

[0025] The non-claimed circumferential collar further comprises a cable-tie ratcheting fit adjustment system, comprising one or more cable-tie type ratcheting tabs; and one or more receivers for said tabs, wherein each of the cable-tie type ratcheting tabs is disposed so as to pass through a receiver. The receivers are configured to allow movement of a ratcheting tab through the receiver in one direction thereby reducing the circumference of the circumferential collar, but prevent movement of the ratcheting tab in the reverse direction. Additionally, the ratcheting tabs are configured to break away from the circumferential collar at a point below their corresponding receivers when pulled away from the circumferential collar at a force greater than or equal to a predetermined level.

[0026] The non-claimed circumferential collar further comprises a cable ratcheting fit adjustment system, comprising: one or more cables spanning at least a portion of the circumference of the collar; and one or more ratcheting elements, with each ratcheting element attached to at least one of the cables. In these embodiments, each of the ratcheting elements is configured to adjust the circumference of the collar by adjusting the length of a cable spanning at least a portion of the circumference of the collar. In some further examples, the ratcheting fit adjustment system further comprises an adjustment tool distinct from the circumferential collar, configured to reversibly engage with the ratcheting system. In some alternative embodiments, the ratcheting fit adjustment system further comprises an adjustment tool integral to the circumferential collar.

[0027] The device further comprises one or more discernible graphic or tactile reference points on an exterior surface of the device.

[0028] The non-claimed circumferential collar further comprises one or more sensors capable of detecting pulse, blood pressure, or other indicia of proper placement and pressure of a protuberance above a neck vein. In some further examples, the device further comprises a transmitter operably connected to a sensor, wherein the transmitter is capable of transmitting a signal indicative of a sensor reading to an external device. In some further examples, the device further comprises an electronic circuit operably connected to a sensor, whereby

the electronic circuit is configured to provide visual or auditory indicia of proper fit and/or alignment. In some embodiments, visual indicia may comprise light from a light emitting diode (LED). In some embodiments, auditory indicia may comprise sound from a speaker.

[0029] The device comprises a non-claimed semi-circumferential collar comprising a resilient arcuate band having a general C, V, or U-shape and sized to encircle a majority of the neck of a subject; and one or more inwardly directed protuberances integral to the semi-circumferential collar. In these embodiments, the protuberances are located on the semi-circumferential collar such that they are disposed above one or more neck veins of the subject when the collar is encircling a portion of the neck of the subject; and the collar is sized so as to exert sufficient pressure on the protuberances to restrict blood flow egressing from the head of the subject through the one or more neck veins.

[0030] The non-claimed semi-circumferential collar is sized to be positioned between the collar bone and the cricoids cartilage of the subject.

[0031] The non-claimed semi-circumferential collar has an opening at the front of the neck or at the back of the neck.

[0032] The device comprises: a flexible material sized to encircle a minority of the circumference of the neck of a subject; and one or more inwardly directed protuberances contacting an inner surface of said flexible material. In these embodiments, the flexible material is sized such that an inner surface of the flexible material extends beyond a protuberance, and the protuberances are of appropriate size and shape such that when placed on the neck above a neck vein of the subject, the device restricts blood flow egressing from the head of the subject.

[0033] In some related embodiments, the flexible material comprises a plastic or woven fabric.

[0034] In some related embodiments, a portion of the flexible material that extends beyond a protuberance is coated with an adhesive.

[0035] In some related embodiments, the flexible material is an elastic material. Alternatively, in some related embodiments, the flexible material is an inelastic material.

[0036] In some related embodiments, a protuberance is defined by an outward bend point of a resilient arcuate band having a general C, V, or U-shape.

[0037] In some related embodiments, the devices are intended to be applied to the neck of a subject in pairs. In some related embodiments, two of such devices are attached to each other by a removable tether; wherein the removable tether is sized to facilitate appropriate spacing and alignment during application to the neck of a subject.

[0038] Further disclosed herein is a device which comprises a resilient arcuate band having a general C, V, or U-shape and sized to encircle a minority of the neck of a subject, and one or more inwardly directed protuber-

ances. In these embodiments, when applied to the neck of a subject, the resilient arcuate band is configured to apply pressure to one or more protuberances to restrict blood flow egressing from the head of the subject.

[0039] Further disclosed herein are non-claimed garments comprising: a collar sized to at least partially encircle the neck of a subject; and one or more inwardly directed protuberances integral to the collar. In such garments, the wherein the protuberances are located on the collar such that they are disposed above one or more neck veins of the subject when the garment is worn; and wherein the garment provides sufficient pressure on the protuberances to restrict blood flow egressing from the head of the subject through the one or more neck veins.

[0040] As used herein, the term "circumferential collar" is used to describe a non-claimed device which encircles the entire circumference of the neck when the device is worn by an animal or human subject. As used herein, the term "semi-circumferential collar" is used to describe a non-claimed device which encircles a majority of the circumference of the neck when the device is worn by an animal or human subject. The portion of the circumference of the neck that is not encircled by a semi-circumferential collar may be disposed at any location around the circumference of the neck, so long as the encircled portion allows for application of pressure on a neck vein of the wearer. Typically, the open portion will be located either at the front of the throat (e.g., in some embodiments, a semi-circumferential collar may encircle the neck except an area substantially defined by laryngeal prominence), or the open portion will be located at the back of the neck. Additional details are described below.

[0041] The non-claimed collar may comprise a textile. In related embodiments, the collar may comprise an elastic material.

[0042] The non-claimed circumferential or semi-circumferential collar may comprise a semi-rigid shape-memory material, such as a suitable polymer (e.g., an elastomer) or shape-memory alloy.

[0043] The collar size and tension thereof can be adjustable. In some embodiments of this aspect of the disclosure, the device can further comprise one or more breakaway release mechanisms.

[0044] At least one region of the non-claimed device inwardly directed to contact the neck of a subject can be formed by inflation of a region of the collar, and wherein the device optionally further comprises a pump to inflate the inflatable protuberance, or any region of said device, and optionally a source of pressurized gas or fluid for inflation thereof. In some embodiments of this aspect of the disclosure, the device can further comprise a release valve to regulate the pressure in said collar.

[0045] The disclosure further encompasses a non-claimed method of increasing the intracranial volume and pressure of an animal or human subject comprising: (i) encircling the neck of an animal or human subject with a collar, wherein said collar has at least one region inwardly directed to contact the neck of an animal or human sub-

ject; (ii) positioning the at least one region inwardly directed to contact the neck on a region of the neck overlying a neck vein carrying blood from the intracranial cavity of the subject; and (iii) applying pressure to the neck vein by pressing the at least one region inwardly directed to contact the neck onto the surface of the neck, thereby restricting blood flow egressing the intracranial cavity of the subject, thereby increasing the intracranial pressure and or volume of the subject. It is thus in another aspect envisaged that in said method of increasing the intracranial volume and pressure of an animal or human subject a device of the present invention is applied. Accordingly, the present invention contemplates a device as disclosed herein for use (in a method) of increasing the intracranial volume and pressure of an animal or human subject, said method comprising steps (i) to (iii) as described above.

[0046] According to various embodiments of the invention, a method for mitigating injury to the inner ear, ocular structure and the spinal column is provided, and for preventing loss of olfactory function. In the method for mitigating injury to the inner ear, pressure is applied to the jugular veins to thereby increase cochlear fluid volume and pressure during the concussive event. In the method for mitigating injury to the ocular structure, pressure is applied to the jugular veins to thereby increase intraocular fluid pressure during the concussive event. In the method for mitigating injury to the inner ear, pressure is applied to the jugular veins to thereby increase cerebrospinal fluid volume and pressure during the concussive event. Applying pressure to the jugular veins also reduces or prevents loss of olfactory sense due to increased intracranial volume and pressure. Similarly, the present invention provides a device for use (in a method) for mitigating or preventing injury to the inner ear, ocular structure and the spinal column, and for preventing loss of olfactory function.

[0047] Generally, it is preferred that in the method of the present invention a device as disclosed herein is applied. Accordingly, it is a generally preferred embodiment that a device as disclosed herein is used in a method of the present invention or is used for the purpose of the method of the present invention.

BRIEF DESCRIPTION OF THE DRAWINGS

[0048] Further aspects of the present disclosure will be more readily appreciated upon review of the detailed description of its various embodiments, described below, when taken in conjunction with the accompanying drawings.

FIGS. 1(a)-1(c) are top and side views of a non-claimed compression collar according to one disclosed embodiment.

FIG. 2 is a top view of a non-claimed compression collar according to a further disclosed embodiment.

FIG. 3 is a top view of a non-claimed compression collar according to another disclosed embodiment.

FIG. 4 is a top view of a non-claimed compression collar of another embodiment incorporating a compression indicator.

FIG. 5 is a top view of an overlay to be mounted on the non-claimed collar of **FIG. 4**.

FIG. 6 is a top partial view of the non-claimed compression collar and overlay of **FIGS. 4-5**.

FIGS. 7(a)-7(c) are successive views of the overlay and indicator strips of the non-claimed compression collar shown in different degrees of stretch of the collar.

FIG. 8 is a graph illustrating the change in intracranial pressure (ICP) as a consequence of IJV compression, p-value <0.01.

FIG. 9 is a graph illustrating the change in intraocular pressure (IOP) as a consequence of IJV compression, p-value 0.01.

FIG. 10 is a graph showing a representative tracing of physiologic change seen in intracranial pressure (ICP) and intraocular pressure (IOP) over a fifteen minute period caused by the application (arrow on left) and removal of IJV compression (arrow on right). Of note is the rapid response seen in both ICP and IOP and corresponding volumes following IJV compression as well as the duration for which these changes are sustained.

FIG. 11A is a digital image of corticospinal tracts stained for APP post-injury without application of the IJV compression device according to the disclosure.

FIG. 11B is a digital image of corticospinal tracts stained for APP post-injury with application of the IJV compression device according to the disclosure.

FIG. 12 is a graph illustrating the effect of IJV compression on axonal injury as indicated by APP staining, p-value <001.

FIG. 13 shows an illustration of a non-claimed circumferential collar made of an elastic material.

FIG. 14 shows an illustration of a non-claimed circumferential collar, a fastener for opening and closing, and two protuberances configured to apply pressure to a neck vein of a wearer.

FIG. 15 shows an illustration a non-claimed circumferential collar, a fastener for opening and closing, a

laryngeal bridge, and two protuberances configured to apply pressure to a neck vein of a wearer.

FIG. 16 shows an illustration of a non-claimed circumferential collar comprising two pieces: a first piece (i.e., front section) comprising and two protuberances each configured to apply pressure to a neck vein of a wearer, and second piece (i.e., back section) comprising a fabric collar configured to be removably attached to either end to the first piece.

FIG. 17 shows an illustration of a non-claimed circumferential collar, a fastener for opening and closing, and two protuberances each (comprising a bladder and a pressure release valve) configured to apply pressure to a neck vein of a wearer.

FIG. 18 shows an illustration of a non-claimed semi-circumferential collar with a front opening.

FIG. 19 shows an illustration of a non-claimed semi-circumferential collar with a back opening.

FIGs. 20A-B show illustrations of exemplary embodiments of the present invention that apply pressure on appropriate positions on the neck without the use of a circumferential collar. These embodiments are typically worn as pairs, with a device worn one either side of the neck.

FIG. 21 is an illustration of another embodiment of the present invention that applies pressure on appropriate positions on the neck without the use of a circumferential collar. The device shown in **FIG. 21** is similar to those of **FIGs. 20A-B**, but further includes a removable tether of the appropriate length between a pair of devices that acts as an alignment and spacing guide for application to the neck.

FIG. 22 is an illustration of another embodiment of the present invention that applies pressure on appropriate positions on the neck without the use of a circumferential collar. In this embodiment, the device comprises a U-shaped resilient band with a protuberance disposed on one or both ends.

FIG. 23 is an illustration of a non-claimed circumferential collar type device comprising a pull-away cable-tie type ratcheting fit adjustment system, wherein the pull-away cable-tie is configured to release from the collar when pulled at or above a specific pressure.

FIG. 24 is an illustration of a non-claimed circumferential collar type device comprising a rotating ratchet fit adjustment system and an external adjustment tool.

FIG. 25 is an illustration of a non-claimed circumferential collar type device comprising a rotating ratchet fit adjustment system with an integrated adjustment dial.

FIG. 26 is an illustration of a non-claimed circumferential collar type device comprising one or more discernible graphic or tactile reference points on an exterior surface of the device to assist placement and/or alignment on the wearer.

FIG. 27 is an illustration of a non-claimed device which comprises a sensor configured to detect pulse, blood pressure, or other indicia of proper placement and pressure of a protuberance above a neck vein, and means to transmit a signal from the sensor to an external device.

FIG. 28 is an illustration one or more protuberances which are integral with a non-claimed garment.

[0049] The drawings are described in greater detail in the description and examples below.

DETAILED DESCRIPTION

[0050] The details of some exemplary embodiments of the method and systems (devices) as well as the system for use in the method of the present disclosure are set forth in the description below. Other features, objects, and advantages of the disclosure will be apparent to one of skill in the art upon examination of the following description, drawings, examples and claims. It is intended that all such additional systems, methods, features, and advantages be included within this description, be within the scope of the present disclosure, and be protected by the accompanying claims.

[0051] Before the present disclosure is described in greater detail, it is to be understood that this disclosure is not limited to particular embodiments described, and as such may, of course, vary. It is also to be understood that the terminology used herein is for the purpose of describing particular embodiments only, and is not intended to be limiting, since the scope of the present disclosure will be limited only by the appended claims.

[0052] When liquid in a tank or vessel experiences dynamic motion, a variety of wave interactions and liquid phenomena can exist. The oscillation of a fluid caused by external force, termed "sloshing", occurs in moving vessels containing liquid masses. This sloshing effect can be a severe problem in energy absorption, and thus, vehicle stability and control. The present disclosure encompasses methods and apparatus for reducing SLOSH effects in living creatures, and in particular in the intracranial and spinal regions of the animal or human subject.

[0053] The mitigation of blast wave and collision damage is based largely on the principle of energy absorption of fluid-filled containers. As there becomes more room

for movement of fluid within a vessel, more energy can be absorbed (SLOSH) rather than transmitted through the vessel. To reduce this energy absorption, one must attempt to more closely approximate elastic collisions. Elastic collisions are those that result in no net transfer of energy, chiefly, acoustic, kinetic, vibrational, or thermal (also stated as a coefficient of restitution (r) approximating 1.0). Various embodiments described below may locally alter, elevate, or temporarily maintain an altered physiology of an organism to reduce the likelihood of energy absorption through SLOSH whereby the coefficient of restitution (r) is increased. The coefficient of restitution (r) indicates the variance of an impacting object away from being a complete total elastic collision (an (r) of 1.0 = no energy transfer). Blast or energy absorption in an organism can be viewed as a collision of bodies and thus be defined by a transfer of energies through elastic or inelastic collisions. The mechanisms for biological fluids and molecules to absorb energy can thus be identified and the resultant means to mitigate that absorption can be achieved through several SLOSH reducing techniques. Dissipation of energies post blast is also potentiated through these techniques.

[0054] SLOSH absorption may be reduced by reversibly increasing pressure or volume within the organs or cells of the organism. Applying this concept to the contents of the skull, the intracranial volume and pressure can be reversibly increased by a device that reduces the flow of one or more of the cranial outflow vessels. One embodiment of such a device would compress the outflow vessels enough to cause an increase in venous resistance, yet not enough to increase an arterial pressure leading into the cranium above approximately 80 mm Hg. The present invention therefore provides a device for use (in a method) of reducing the flow of one or more of the cranial outflow vessels.

[0055] Mitigating SLOSH by increasing the pressure of the fluid contents of the brain can significantly reduce the propensity for damage to the brain tissue or its blood vessels by reducing the compressibility of the brain. The reduction in compressibility results in reduced absorption of kinetic, acoustic, thermal, and vibrational energy by the brain. The present invention thus provides a device as disclosed herein for use (in a method of) mitigating SLOSH by increasing the pressure of the fluid contents of the brain, preferably by internal jugular vein compression. Put differently, the present invention also provides a device as disclosed herein for use (in a method) of reducing the compressibility of the brain.

[0056] Intracranial volume can also be reversibly increased by increasing the $p\text{CO}_2$ in the arterial blood or by the delivery of one or more medicaments to facilitate an increase in intracranial volume or pressure including but not limited to Minocycline, insulin-like growth factor 1, Provera, and Vitamin A. Such techniques may be used in combination with use of the devices disclosed herein or in combination with the uses or methods as disclosed herein.

[0057] With respect to the inner ear, it is known that the cochlear aqueduct is in direct communication with the cerebrospinal fluid (CSF) and the vein of the aqueduct drains directly into the internal jugular vein (IJV). The venous blood empties either directly into the inferior petrosal sinus or internal jugular vein, or travels through other venous sinuses via the vein of the vestibular or cochlear aqueduct. Reduced outflow of the internal jugular would necessarily congest the cochlear vein and take up the compliance of the inner ear, thereby improving elastic collisions at the macroscopic, cellular, and molecular level and, thus, reducing energy impartation into these structures.

[0058] Approximately 30 ml (21 %) of a total CSF volume of 140 ml resides within the spinal axis, and about one-third of the compliance of the CSF system has been attributed to the spinal compartment. As in the brain, increasing the pressure and volume of the CSF within the spinal compartment reduces the susceptibility of the spinal compartment to concussive injuries by increasing the elasticity of the contents of the spinal column, thereby reducing the amount of energy absorbed by the contents of the spinal column when subjected to a concussive force.

[0059] With respect to ocular injuries, it is known that the woodpecker has a "pectin apparatus" that protects the globe of its eyeball from the 1200G impact of pecking. The sole purpose of the pectin apparatus appears to be to increase the volume and pressure of the vitreous humor inside the eyeball. The pectin apparatus is situated within the eyeball and fills with blood to briefly elevate intraocular pressure, thereby maintaining firm pressure on the lens and retina to prevent damage that might otherwise occur during the 80 million pecking blows over the average woodpecker's lifetime. While humans lack the pectin apparatus, it is possible to increase intraocular pressure by externally applying pressure on the external jugular veins (EJV).

[0060] One aspect of the present invention, therefore, encompasses a device that raises intracranial volume and pressure and/or intraocular pressure when worn by a subject animal or human. The device is configured to apply pressure to the outflow vasculature in the neck (e.g., one or more internal and/or external jugular vein), thus increasing intracranial and/or intraocular pressures and volumes in the wearer. In doing so, the device reduces energy absorption by the wearer due to concussive effects, thus reducing the likelihood of one or more of brain, spine, and eye damage from a concussive event. Devices of the instant invention could be worn preferably before, in anticipation of and during events with SLOSH and traumatic brain injury risks. The present invention also provides a device for use (in a method) of raising intracranial volume and pressure and/or intraocular pressure when worn by a subject animal or human.

[0061] Safely and reversibly increasing cerebral blood volume by any amount up to 10 cm^3 and pressure by any amount up to 70 mmHg would serve to fill up the com-

pliance of the cerebral vascular tree and thus reduce the ability to absorb external energies through SLOSH energy absorption. With the application of measured pressure to the neck, the cranial blood volume increases rapidly and plateaus at a new higher level. Moyer et al reported that cerebral arterial blood flow was not affected by obstructing the venous outflow of blood from the brain. The blood volume venous pressure relationship shows a diminishing increase in volume with each increment of neck pressure over the range 40 to 70 mm of mercury. It is of interest that the cranial blood volume increases from 10 to 30 per cent (with this neck pressure). Similarly, CSF pressure also increases upon compression of the individual jugular veins. Under the same neck pressure, the average rise in CSF pressure is about 48%. These changes occur very rapidly upon initiation of pressure; jugular compression increases cerebral blood flow to a new plateau in as little as 0.5 seconds. Although lesser cranial pressure and volume increases may still have beneficial effects, it is intended that devices of the instant invention increase cranial blood volume by at least 3cm³ through an application of at least 5mm Hg neck pressure. In some embodiments, the devices apply between about 5-70 mmHg, such as between about 5-60 mmHg, such as between about 5-50 mmHg, such as between about 5-40 mmHg, such as between about 5-30 mmHg, such as between about 5-20 mmHg, such as between about 5-10 mmHg of pressure to the neck veins. Accordingly, the present invention therefore provides a device for use (in a method) of increasing cranial blood volume as described before in the context of the device.

[0062] Devices of the present invention, therefore, may take many forms, but share the functional feature of constantly or intermittently applying pressure to one or more veins in the neck (specifically, but not limited to the internal and external jugular veins, the vertebral veins, and the cerebral spinal circulation, and most preferably, the interior jugular vein) to restrict blood flow exiting the brain. Thus, the instant devices include at least one inwardly directed protuberance that is inwardly directed and contacts the neck of the wearer of the device, and at least one means for applying pressure to the one or more protuberances such that the protuberances apply pressure to one or more veins in the neck, thereby restricting blood flow exiting the brain.

Inwardly Directed Protuberances That Contact the Neck of the Wearer

[0063] In some embodiments, the one or more inwardly directed protuberances are integral to the component of the device responsible for applying pressure to the neck. In alternative embodiments, the one or more inwardly directed protuberances are distinct from the component of the device responsible for applying pressure to the neck. It is to be generally understood that the protuberances may be any suitable shape, e.g., pointed or round, and comprising of any suitable material, such as defined

by a rigid or semi-rigid plastic body, a thickened region of a collar, and the like.

[0064] In some embodiments, the protuberances may substantially be defined by a bladder, whereby pressure is exerted on the neck of the wearer when the bladder is inflated or filled. In some related embodiments, the bladder may contain reversibly compressible foam that is in fluid communication with the external atmosphere. In further related embodiments, the interior of the bladder is in fluid communication with the external atmosphere via a pressure release valve. In embodiments comprising a bladder, foam, and valve, these components may be configured so that the foam expands within the bladder, drawing air into the bladder through the pressure valve to inflate the bladder to a desired pressure. However, the pressure release valve may be configured to allow for release of air from the bladder upon an application of pressure to the device that may otherwise raise the amount of pressure applied to the neck to an uncomfortable or undesirable level. In other embodiments, the bladder may contain a gas or liquid and may be outfitted or configured to interface with a pump mechanism such that the pressure of the bladder may be user adjusted. The pump mechanism may be any suitable pump mechanism as would be understood in the art, such as e.g., a powered pump, or a hand-compressible pump whereby a liquid, air or a gas can be applied to the bladder. In certain embodiments the device may further comprise a pressure sensor operably linked to the pump mechanism or bladder whereby the degree of inflation may be regulated as to the extent and duration of the pressure applied to an underlying neck vein.

[0065] In some embodiments, the protuberance comprises a spring or resilient compressible material. In these embodiments, the spring or resilient compressible material is disposed within the protuberance such that application of the protuberance to the neck at least partially compresses the spring or resilient compressible material. The force exerted by the at least partially compressed spring or resilient compressible material ensures that the protuberance maintains a desired pressure on the neck.

[0066] In some embodiments, the device may comprise a resilient arcuate band having a general C, V, or U-shape. The band may be formed of a resilient spring-like material whereby the C, V, or U-shaped band is forced open as the device is applied. After application of the device, spring tension causes compression of the band, resulting in the mid-point or bend-point of the band to extend toward and apply pressure to the neck. Thus, in these embodiments, the mid-point or bend-point of the bands are the protuberances that contact the neck of the wearer.

[0067] In some embodiments, at least a portion of an inwardly directed surface of the one or more protuberances may be coated with a suitable adhesive to facilitate placement of the protuberances on the neck, and prevent movement of the protuberance once in place. Additionally or in the alternative, in embodiments where the pro-

tubercles are distinct from the component of the device which applies pressure to the neck, at least a portion of an outwardly directed surface of the one or more protuberances may be coated with a suitable adhesive. In such embodiments, the design of the device may be such that a protuberance may be placed between a component which applies pressure to the neck and the neck itself. An outwardly directed surface of the protuberance would then contact an inwardly directed surface of the pressure-providing component of the device such that the adhesive on the outwardly directed surface of the protuberance would prevent movement of the protuberance once in place.

[0068] One example of this type (discussed in greater detail below) comprises three pieces: two round or oval plastic protuberances (one for application to either side of the neck) and an elastic collar. The device could be applied by first putting the collar around the neck, and then by placing the plastic protuberances between the collar and the neck at the appropriate locations so as to apply pressure to the internal jugular vein on either side of the neck. As will be appreciated for this example, a mild adhesive coating on the inwardly directed and/or outwardly directed surfaces of the protuberances will assist in preventing movement of the protuberances once they are installed between the collar and the neck. Alternatively, if the protuberances have an adhesive coating of sufficient strength at least on the inwardly directed surfaces, the protuberances may be placed on the appropriate locations on the neck prior to installation of the collar. In either case, the collar applies pressure to the protuberances, which in turn applies pressure to the neck veins.

[0069] In other embodiments of this type, two protuberances may be secured to one another with a tether of the appropriate length to act as an alignment and spacing guide for application on either side of the neck. In some embodiments, the tether may be removable, so that once the protuberances are applied to the neck, the tether may be pulled or otherwise removed, leaving the protuberances in place on the neck of the wearer.

[0070] In some embodiments, the protuberances are compressible pads or solid forms sized to apply pressure substantially only to the internal jugular vein.

Non-claimed Circumferential and Semi-Circumferential Collar Type Devices

[0071] In some other disclosed illustrative examples, the device may be a circumferential or semi-circumferential collar. A circumferential collar is a collar that encircles the entire circumference of the neck when the device is worn by an animal or human subject. A semi-circumferential collar is a collar that encircles a majority of the circumference of the neck when the device is worn by an animal or human subject. The portion of the circumference of the neck that is not encircled by a semi-circumferential collar may be disposed at any location around

the circumference of the neck, so long as the encircled portion allows for application of pressure on inwardly directed protuberances specifically located in order to restrict blood flow exiting the brain. Typically, the open portion will be either located at the front of the throat (e.g., in some examples, a semi-circumferential collar may encircle the neck except an area substantially defined by laryngeal prominence, also known as the "Adam's apple"), or located at the back of the neck.

[0072] Where the device comprises a circumferential collar, it is contemplated that the applied pressure to the neck may be due to an internal dimension of the collar being less than the neck diameter. This difference in internal dimension of the collar may be achieved by any number of configurations dictated by the materials used to construct the collar. For instance, in a collar comprising inelastic materials, the collar may be sized to apply the appropriate pressure when worn by an individual. The size of the collar may be such that the collar is tailored to an individual and thus requires no adjustment for fit. Alternatively, the size of the collar may be adjustable by any of a number of means, some of which are discussed further below. The collar may comprise an elastic material such that the internal dimension of the elastic collar is expanded when the collar is worn, and the collar applies pressure to the neck of the wearer as a result of compressive force exerted by the expanded elastic material. Elastic materials may also confer the benefit of increased comfort for the wearer.

[0073] Where the device comprises a semi-circumferential collar, it is contemplated that the collar comprises a resilient arcuate band having a general C, V, or U-shape. The band extends a majority, if not the entirety, of the length of the collar. The collar thus semi-rigidly defines a C, V, or U-shape that is expanded as the collar is applied to the neck of a wearer. Spring tension from the expanded resilient arcuate band causes a compressive force that keeps the collar in place on the neck and applies the intended pressure to the neck veins.

[0074] At least one inwardly directed pad or form may be disposed at appropriate locations on opposing sides of the collar, such that the inwardly directed pads or forms are configured to contact the neck and apply pressure to a point above the interior jugular vein. Where the semi-circumferential collar is open at the front of the throat, the area of the neck not covered by the semi-circumferential collar may define a region approximating the laryngeal prominence, also known as the "Adam's apple." The inwardly directed pad or forms disposed on opposing sides of the collar may be located at or near the terminal ends of the resilient arcuate band. Where the semi-circumferential collar is open at the back of the neck, the inwardly directed pads or forms may not be disposed near the terminal ends, but rather may be disposed much closer to the mid-point of the band.

[0075] Where the device comprises a circumferential collar or a semi-circumferential collar that is open at the back of the neck, the device may comprise a laryngeal

bridge that defines a cut-out at the front of the neck. The size and shape of the laryngeal bridge may be configured so as to minimize contact of the collar with the laryngeal prominence in order to make the collar more comfortable for the wearer. The laryngeal bridge may be of any suitable material as to provide a rigid or semi-rigid continuation of the collar around the front of the neck. The laryngeal bridge may comprise thick or reinforced textile material, plastic, metal, or any combination thereof.

[0076] Where the device comprises a circumferential collar, the device comprises two components: a front section comprising the one or more inwardly directed protuberances and a laryngeal bridge, and a back section comprising a length of fabric configured to be removably attached at either end to corresponding ends of the front section. The length of fabric comprises an elastic material; alternatively, the length of fabric may comprise an inelastic fabric. Removable attachment of either end of the front section to the corresponding end of the back section may be by any suitable method known in the art, such as a hook and ladder attachment, a hook and loop attachment, a snap, a button, a chemical adhesive, or any of a number of attachment mechanisms that would be known to one skilled in the art. A device with removable attachment means could also have a breakaway release mechanism whereby the device can break open or apart at a predetermined force to prevent the device from inadvertently being snagged or compressing too tightly.

[0077] Many of the devices described herein are described as potentially comprising an elastic material. More particularly, it is intended that these devices may comprise materials that are elastically elongatable around the circumference of a subject's neck. Elastic materials can be any material which when stretched will attempt to return to the natural state. Exemplary materials may include one or more of textiles, films (wovens, non-wovens and nettings), foams and rubber (synthetics and natural), polychloroprene (e.g. NEOPRENE®), elastane and other polyurethane- polyurea copolymers (e.g. SPANDEX®, LYCRA®), fleece, warp knits or narrow elastic fabrics, raschel, tricot, milanese knits, satin, twill, nylon, cotton tweed, yarns, rayon, polyester, leather, canvas, polyurethane, rubberized materials, elastomers, and vinyl. There are also a number of elastic materials which are breathable or moisture wicking which may be preferable during extended wearing periods or wearing during periods of exercise. As indicated above, elastic materials may confer the benefit of increased comfort for the wearer by providing sufficient compressive pressure, yet remaining flexible to accommodate a full range of motion and/or muscle flex in the wearer.

[0078] In addition, a device constructed with an elastic material may be partially reinforced, coated, or otherwise include one or more protecting materials such as Kevlar® (para-aramid synthetic fibers), Dyneema® (ultra-high-molecular-weight polyethylene), ceramics, or shear thickening fluids. Such reinforced materials may confer the benefit of increasing the devices resistance to lacer-

ations. As such, reinforced devices may provide the user the added benefit of protecting the neck from damage from lacerations.

[0079] Non-claimed circumferential or semi-circumferential collars may be constructed with materials, elastic or otherwise, that are fire resistant.

[0080] The device may encompass horizontally, the entire neck or just partially up and down the neck. The width of the devices described herein may range from a mere thread (at a fraction of an inch) to the length of the exposed neck (up to 30.48 cm (12 inches) in humans or greater in other creatures), the length may range from 15.24 cm to 91.44 cm (6 to 36 inches) to circumnavigate the neck. The width of the compression device could be as small as 0.635 cm (1/4 inch) but limited only by the height of the neck in largest width, which would be typically less than 15.24 cm (6 inches). The thickness of said device could range from a film being only a fraction of a millimeter to a maximum of that which might be cumbersome yet keeps ones neck warm, such as 5.08-7.62 cm (2-3 inches) thick.

[0081] The device may be pre-formed for the user in a circular construct. This one size fits all style can have a cinch of sorts that allows one to conform the device to any neck size. Alternatively the device may have a first end and a second end which are connected by a fastener. A fastener may be magnetic, a tack strip, a hook and ladder attachment, a hook and loop attachment, a ply strip, one or more slide fasteners, one or more zippers, one or more snaps, one or more buttons, one or more safety pin type clasp mechanisms, overlapping electrostatic contact materials, or any of a number of attachment mechanisms that would be known to one skilled in the art. A device with a fastener could have a breakaway release mechanism whereby the device can break open or apart at a predetermined force to prevent the collar from inadvertently being snagged or compressing too tightly. One quick release or automatic release example would be the applying of small amounts of hook and ladder attachments within a circumferential ring which would shear apart upon too much force being applied to the device.

[0082] Also, the device could fasten such that the user would be able to pull one end of the collar (like a choker collar for a dog) and the force exerted by the user effectually decreases the length or circumference of the device. When the desired neck compression is no longer needed (such as between football plays) the user could then release the compression by a second gentle tug or by a separate release mechanism also positioned on the device.

[0083] Other fit adjustment systems may be used in the collar-type devices described herein. For example, a pull-away cable-tie (e.g., Zip-tie®) type ratcheting fit adjustment system may be included. This type of system may include one or more pull-away cable-ties configured to release from the collar when pulled at or above a specific pressure, thus ensuring that the collar is not over

tightened. Alternatively, a rotating ratcheting fit adjustment system may be included. The system may be designed such that an external tool is employed fit adjustment. Preferably, such systems utilize elastic materials and or an adjustable fastener system (as described above) such as a Velcro® closure-system to provide a gross-fit of the device. The ratcheting adjustment system would then be used for fine-adjustments of the device specific for an individual wearer. As an alternative to an external tool system, rotating ratchet fit adjustment systems which include an integrated adjustment dial, e.g., a BOA® rotating ratchet fit adjustment system as described in U.S. Pat. No. 8,381,362 and U.S. Pat. Pub. No. 2012/0246974.

[0084] The circumferential or semi-circumferential collar may comprise a shape memory polymer. In that case, the collar would be applied to the neck of a user, then the appropriate stimulus would be applied to the shape memory polymer, causing the collar to shrink to fit.

[0085] The circumferential or semi-circumferential collar may comprise a bladder whereby the pressure exerted on the neck of the wearer by the collar may be adjusted by inflating or deflating the bladder. The bladder may contain reversibly compressible foam that is in fluid communication with the external atmosphere. In further cases, the interior of the bladder is in fluid communication with the external atmosphere via a pressure release valve. When a bladder, foam, and valve are present, these components may be configured so that the foam expands within the bladder, drawing air into the bladder through the pressure valve to inflate the bladder to a desired pressure. However, the pressure release valve may be configured to allow for release of air from the bladder upon an application of pressure to a protuberance that may otherwise raise the amount of pressure applied to the neck to an uncomfortable or undesirable level. In other examples, the bladder may contain a gas or liquid and may be outfitted or configured to interface with a pump mechanism such that the pressure of the bladder may be user adjusted. The pump mechanism may be any suitable pump mechanism as would be understood in the art, such as e.g., a powered pump, or a hand-compressible pump whereby a liquid, air or a gas can be applied to the bladder. The device may further comprise a pressure sensor operably linked to the pump mechanism or bladder whereby the degree of inflation may be regulated as to the extent and duration of the pressure applied to an underlying neck vein. In some cases, the bladder is disposed to at least include a portion of the collar other than above a protuberance. In some cases, the bladder is disposed through a majority of the circumference of the collar.

[0086] A circumferential or semi-circumferential collar may further comprise a pouch or pocket. This pouch or pocket may be externally accessible, i.e., accessible while the collar is being worn, or only accessible when the collar is removed. The dimensions of such a pouch or pocket may be such that the pouch or pocket is suitable

to carry one or more items useful for the treatment of TBI related calamities, such as a material enabling CO₂ delivery, carbonic anhydrase tablets, methylene blue, DHA, smelling salts, etc.

[0087] A circumferential or semi-circumferential collar may further comprise an electrical circuit comprising a piezoelectric heat pump configured to alter the temperature of the inwardly directed surface of the collar. Such a heat pump may be used to either heat or cool the device, for example by as much as 70° from ambient temperature.

[0088] A circumferential or semi-circumferential collar may further comprise an electrical circuit configured to provide a therapeutic electrical stimulation to the neck of the wearer. For example, an electrical circuit may be configured to provide transcutaneous electrical nerve stimulation.

Non-Collar Type Devices

[0089] In some embodiments, the device may be a non-collar type device. Non-collar type devices are those that cover or encircle a minority of the circumference of the neck when the device is worn by an animal or human subject. However, the portion of the circumference of the neck that is covered or encircled by non-collar type devices must at least include one or more areas of the neck above a neck vein, as described above. As with collar-type devices, non-collar type devices also utilize inwardly directed protuberances to apply pressure to the neck at specific locations in order to restrict blood flow exiting the brain. Any of the protuberances described above may find use in non-collar type devices.

[0090] In some embodiments, the externally directed side of a protuberance may be covered by flexible material that extends beyond the area defined by the protuberance. In these embodiments, at least a portion of this extended inwardly directed surface contacts the neck when the device is in place. In some embodiments, the at least a portion of the inwardly directed surface of the flexible material that contacts the neck is coated with an appropriate adhesive, such that when applied to the neck, the flexible material holds the protuberance in an appropriate position and applies pressure to a neck vein. The flexible material may be elastic or non-elastic. The flexible material may be any suitable synthetic or natural woven or textile material, or any suitable plastic.

[0091] Such embodiments may comprise a pair of material/protuberance combinations for application to both sides of the neck. Some related embodiments may comprise a pair of material/protuberance combinations joined by a tether, as described above. The tether may be of appropriate length so as to serve as an aid to alignment and proper placement of the protuberances at the correct locations on the neck. In some embodiments, the tether may be removably attached to the pair of material/protuberance combinations so that after placement of the protuberances on either side of the neck, the tether is re-

moved.

[0092] In some non-collar type devices, the device may comprise a resilient arcuate band having a general C, V, or U-shape. In these embodiments, it is intended that a protuberance is located at or near the terminus of each arm of the band, and that when the device is in place, the band extends around the front of the neck. In these embodiments, the band thus semi-rigidly defines a C, V, or U-shape that is expanded as the device is applied to the neck of a wearer. Spring tension from the expanded resilient arcuate band causes a compressive force that keeps the device in place on the neck and applies the intended pressure to the neck veins via the protuberances. In some embodiments, the resilient arcuate band is sized and shaped such that it does not cross the front of the neck in the general area of the laryngeal prominence. Instead, the band may cross the front of the neck at a position below the laryngeal prominence.

Non-claimed Garments or Other Protective Gear Comprising Integral Protuberances

[0093] In other illustrative cases, it is envisioned that protuberances (as described above) may be incorporated into various articles of clothing and/or other protective gear. Such garments and/or other protective gear typically may be designed for specific purposes, e.g., as part of a military uniform, sporting apparel, neck guard for first responders, flame retardant head gear for automobile or motorcycle drivers or firefighters, etc. In any case, protuberances may be included at the appropriate positions in a portion of a garment or protective gear that contacts the neck of the wearer, i.e., the collar, with the collar providing compressive force on the protuberances. As such, any of the closing, alignment, or fitting means, or any other optional feature provided in regards to circumferential or semi-circumferential collar-type devices may be incorporated in garment and/or protective gear.

[0094] In some cases, at least the collar of the garment comprises an elastic material.

Visual or Tactile Alignment Aids

[0095] Any of the embodiments and illustrative examples described above may further comprise one or more materials, and/or apply one or more construction methods, designed to provide the user or a 3rd party observer with a visual or tactile aid in determining proper alignment and positioning of the protuberances. For instance, a collar type device may include a small strip or patch of a contrasting or reflective material, or a material with a different texture, at the mid-point of the neck. Alternatively or in addition, similar visual or tactile cues may be incorporated into any of the above devices so as to provide an outward indication of the location of a protuberance.

[0096] Further, any of the embodiments described above that utilize elastic materials may comprise a dual layered elastic material that exposes a change in graphic

or color when sufficiently stretched to apply an appropriate force on an underlying protuberance. In such embodiments, the change in graphic or color may provide a visual cue to the wearer or 3rd party observer that the device is applying at least sufficient compressive force.

Non-claimed Incorporated Sensors or Other Electronic System

[0097] Any of the above devices may also have one or more monitoring, recording, and/or communicating devices attached or embedded. For example, the device may comprise a sensor capable of detecting one or more environmental parameters around the wearer, one or more physiological parameters of the wearer, or some combination thereof. Exemplary environmental parameters that may be detected include time the collar has been worn, barometric pressure, ambient temperature, humidity, acceleration/deceleration (i.e., G forces), positionality (upright/supine), etc. Physiological parameters that may be detected include pulse, blood pressure, plethysmography, dermal temperature, oxygen saturation, carboxy-hemoglobin level, methemoglobin level, blood sugar, electrical flow, etc. of the human or animal wearing the device. Any of such sensors may be used to monitor some environmental or physiological characteristic or performance aspect of the wearer. Sensors capable of detecting pulse, blood pressure, and/or plethysmography may serve the additional or alternate purpose of being used as an alignment and/or fit aid, notifying the user when the protuberance is properly placed over a neck vein and is exerting an appropriate pressure so as to restrict blood flow.

[0098] In some related embodiments, a device may further comprise an electronic circuit capable of providing visual, auditory, or tactile indicia of malfunction, or an undesirable sensor reading. For instance, an electronic circuit may be configured to vibrate the collar when a pulse or blood pressure sensor detects a reading that is either higher or lower than a predetermined value.

[0099] Additionally or in the alternative, any of the above devices may comprise an electronic circuit configured to transmit the location of the wearer. For instance, any of the above devices may comprise an electronic circuit configured to transmit the GPS coordinates of the wearer for tracking the location of the wearer, or for search and rescue purposes.

[0100] Additionally or in the alternative, any of the above devices may comprise an electronic circuit configured to transmit and/or receive voice communications between the wearer and a third party.

[0101] In some embodiments, the output of such a sensor may be visually or audibly communicated to the user or a 3rd party by another component of the device, e.g., an electronic circuit configured to provide a visual or auditory indication (such as with an LED, piezoelectric speaker, etc.). In some embodiments, the device further comprises a communication means such that a signal

from the sensor may be communicated to an external electronic device, such as a smartphone, laptop, or dedicated receiver.

[0102] Further disclosed herein is a non-claimed method of increasing the intracranial pressure of an animal or human subject comprising: (i) encircling the neck of an animal or human subject with a collar, wherein said collar has at least one region inwardly directed to contact the neck of an animal or human subject; (ii) positioning the at least one region inwardly directed to contact the neck on a region of the neck overlying a neck vein carrying blood from the intracranial cavity of the subject; and (iii) applying pressure to the neck vein by pressing the at least one region against the neck. This compression can be as much as 25 mm Hg without any side effects and without impacting the carotid artery. It is believed that pressures as high as 80 mm Hg can be applied without endangering the jugular vein or carotid artery. For many applications of the method, the pressure applied to the neck vein, or jugular vein, can be 3-15 mm Hg. Applying pressure to the jugular vein can increase ICP up to 30% above the baseline pressure to protect the intracranial cavity from blast-related SLOSH effects without any side effects. Similarly, the device is for use in the above-described method of increasing the intracranial pressure of an animal or human subject.

[0103] The present invention also provides a device for applying pressure to one or more neck veins of a subject by using pressure equivalent to a fluid pressure within the range of 5 mmHg to about 50 mmHg. Likewise, the present invention provides a device for reducing the likelihood of injury in a subject exposed to an external concussive force by using pressure equivalent to a fluid pressure within the range of 5 mmHg to about 50 mmHg to said one or more veins of said subject. All embodiments, examples, definitions and disclosure mentioned in the context of devices, methods and uses, respectively, above, are equally applicable to the aforementioned device.

[0104] In a yet further aspect, the present invention provides the use of pressure equivalent to a fluid pressure within the range of 5 mmHg to about 50 mmHg for restricting blood flow egressing from the head of a subject to whose one or more neck veins said pressure is applied to reduce the likelihood of injury in a subject exposed to an external concussive force. Furthermore, the present invention relates to the use of pressure equivalent to a fluid pressure within the range of 5 mmHg to about 50 mmHg applied to one or more neck veins of a subject for reducing the likelihood of injury in a subject exposed to an external concussive force. All embodiments, examples, definitions and disclosure mentioned in the context of devices, methods and uses, respectively, above, are equally applicable to the aforementioned use.

[0105] In a further aspect of the present invention it has been found that applying compression to the internal jugular vein not only reduces the risk of TBI, but also the risk of damage to the inner ear (specifically Noise Induced

Hearing Loss or Blast Induced Hearing Loss), spinal cord and structures of the eye. With respect to the ear, reducing IJV outflow will congest the cochlear vein and thereby take up the compliance of the inner ear or more particularly the fluid within the inner ear. Since the auditory hair cells react directly to the vibrations in the cochlear fluid they are particularly susceptible to SLOSH energy absorption. Increasing the pressure of the fluid within the inner ear reduces the compressibility of the fluid within the inner ear structure so that blast energy is transmitted mechanically through the inner ear rather than absorbed by it in the form of vibration of the fluid. It is noted that increase the fluid pressure does not generally reduce transverse vibrations of the cochlear duct so the transmission of blast energy through the inner ear may still lead to perforation of the eardrum. But in many cases ruptured ear drums will heal or can be repaired. On the other hand, SLOSH-related damage to the fine auditory hair cells does not heal and cannot be repaired.

[0106] With respect to the spinal cord, it has been found that applying the IJV pressure techniques described herein reduces the compliance of fluid along the spinal axis and thus reduces the risk of blast-related spinal injury. The spinal injury mode is similar to the inner ear damage mode in that the spinal cord tracts may be regarded as the sensitive filaments in a fluid environment. Fluid vibration due to SLOSH can damage and may even sever spinal cord tissue. Increasing the CSF pressure by compression of the IJV according to the procedure disclosed herein will significantly reduce the CSF vibration due to blast energy. Moreover, increasing the CSF pressure increase the axial load-bearing capacity of the spinal column which can reduce the likelihood of collapse of the spinal column due to blast energy.

[0107] With respect to the structure of the eye, the injury mode is similar to that of the inner ear and spine in that vibrations (inelastic collisions) of the vitreous humor can lead to permanent damage to the internal structure of the eye. As demonstrated by a woodpecker's pecten apparatus's increasing intraocular volume and pressure which protects the internal structure of the eye; using the compression band to apply pressure to the IJV as disclosed herein the intra-ocular pressure can be increased 36-60%. Safely and reversibly increasing CSF and thereby intra-ocular pressure using the compression band disclosed herein can prevent or at a minimum significantly reduce the vibration and energy absorption of the vitreous humor within the eye, thereby reducing the risk of blast-related damage.

[0108] Finally, as discussed above, the concussive events leading to TBI, has also been found to be a leading cause of anosmia (loss or impairment of olfactory function, i.e., sense of smell). Increasing intracranial pressure as described above can reduce the risk of TBI and the associated impairment of olfactory function. In the case of Breecher or bomb-sniffing dogs the collar may be sized to fit the neck of the animal and the pressure adjusted to account for the greater thickness of the neck at the IJV

over that of a human subject.

[0109] The foregoing description addresses blast-related traumatic injuries to the intracranial cavity, such as TBI, and injuries to the inner ear, spinal cord and ocular structure. The compression devices disclosed herein may thus be worn by military personnel during battle and removed when not in combat. Although certainly less dramatic, certain sports can expose the intracranial cavity to concussive forces that create the risk of these same traumatic injuries, most notably football. The compression collar disclosed herein would be worn by the sports participant in the field of play as well as a multitude of industrial or other potential TBI risky avocations or professions. The collars disclosed herein are relatively non-intrusive and the "break away" feature described above eliminates the risk of the collar being inadvertently pulled.

[0110] These terms and specifications, including the examples, serve to describe the invention by example and not to limit the invention. It is expected that others will perceive differences, which, while differing from the foregoing, do not depart from the scope of the invention herein described and claimed. In particular, any of the functional elements described herein may be replaced by any other known element having an equivalent function.

Non-claimed Illustrative Examples and Embodiments

[0111] Referring to **FIGS. 1(a)-(c)**, a compression collar **10** includes an elongated strap **12** that may be provided in various sizes to encircle the neck of the animal or human subject. The strap may be provided in standard lengths of 35.56, 40.64 and 45.72 cm (14, 16 and 18 inches) to fit the normal range of neck sizes for humans. The width in a specific example may be about 3.81 cm (1.5 inches) to fit within the anatomy of the neck below the laryngeal prominence. To minimize the prominence of the collar, the strap may have a thickness of about 0.3 cm (0.12 inches). The strap **12** may be formed of a woven, breathable, dermatologically inert and nonirritating material, such as cotton or certain polyesters. Since the strap is intended to apply consistent pressure to the jugular vein of the subject the strap material is preferably generally elastic, but formed of an elastic material that will not permanently stretch appreciably over time. It can be appreciated that stretching the material so that the neutral length of the strap is longer than its original condition can render the strap **12** useless. On the other hand, the strap material must be sufficiently elastic or elastically elongatable to remain comfortable when worn for a long period of time, and to flex appropriately with the muscles of the neck. The effective length of the strap **12** is made adjustable by the addition of adjustable engagement elements **16** and **18** at opposite ends of the strap. For instance, in the example shown in **FIG. 1(a)** the latch element **16** defines a serrated channel **16a** that receives the resilient prongs **18a** of the other element. The prongs **18a** are biased to provide an outward force against the

channel **16a** of the latch to hold the prongs at the location of a particular serration **16b**. As illustrated, seven serrations are depicted which provide seven locations for engagement of the prongs **18a** for fine adjustment of the length of the collar. The two components **16,18** may be sewn onto the strap **12** or permanently affixed in a conventional manner sufficient so that the engagement elements will not pull free from the strap during use.

[0112] Two versions of the collar are depicted in **FIGS. 1(a)** and **1(b)**. The version of **FIG. 1(a)** is provided for a male human and includes a cut-out **14** at the location of the laryngeal prominence. The strap **12'** of **FIG. 1(b)** does not include the cut-out and may be typically provided for female human subjects. The cut-out may have a width of about 3.81 cm (1.5 inches) and a depth of about 1.27 cm (0.5 inches) to accommodate the typical laryngeal prominence. It can be appreciated that the collar **10** is engaged around the neck of the subject so that the cut-out **14** is below and sufficiently clear of the prominence to avoid any discomfort to the subject.

[0113] In a further feature of the collars **10, 10'**, a pair of compressible pads **20** are provided spaced apart across the midline of the strap **12, 12'**. The pads are sized and located to bear against the neck at the location of the jugular veins. In one case the pads are spaced apart by about 6.35 cm (2.5 inches), have a width/length dimension of 2.54-3.81 cm (1.0-1.5 inches) and a thickness of about 0.1 cm (0.04 inches). As shown in **FIG. 1(c)** the pads may be partially embedded within the strap **12**. The pads **20** may be formed of a breathable foam that exhibits good recovery from compression. The pads may be formed of a material capable of exerting compression of 5-30 mm Hg when the collar is worn, such as a flexible polyurethane foam.

[0114] In addition to the compression collar are shown in **FIGS. 2** and **3** that incorporate different engagement elements. For instance, the collar **30** of **FIG. 2** incorporates an array of snap pairs **36** at one end that engage a pair of snaps **38** at the opposite end. The snap pairs **36** may be spaced at pre-determined intervals, such as at 0.635 cm (¼ inch) spacings to permit adjustment of the collar diameter when worn. The collar **50** in **FIG. 3** incorporates a row of hooks **56** at one end that engage a corresponding row of loops **58** at the opposite end. **FIG. 3** illustrates that the engagement elements need not be adjustable, although adjustability is preferred. In **FIG. 3** this adjustability may be accomplished by a VELCRO® type connection between the strap **52** and the row of loops **58**. In particular, a VELCRO® type pad interface **59** may be used to mount the loops **58** to the strap at different positions along the length of the strap. In a further alternative, the VELCRO® interface may be between the two ends with mating VELCRO® type pads on each end.

[0115] In one aspect of the compression collars disclosed herein, the engagement elements are preferably configured to break loose or disconnect at a certain load, to avoid the risk of choking or damaging the subject's

neck and throat if the collar is snagged or grabbed. Thus, the engagement elements **16, 18** of **FIG. 1**, the snaps **36, 38** of **FIG. 2** and the hook attachment **59** of **FIG. 3** can be calibrated to disconnect when the collar is pulled with sufficient force. The engagement elements, such as snaps **36, 38**, may be replaced by magnets or a magnet array. The magnets are strong enough to maintain the desired pressure on the jugular veins when the collar is in use. The magnet strength may be calibrated to break loose at a certain load. The break-away feature may also be integrated into the strap apart from the engagement elements. For instance, the strap may incorporate a region between a pad **20** and an engagement element that has a reduced strength so that the strap tears under a certain load. Alternatively, a non-adjustable engagement may be provided in this region calibrated to disengage at a predetermined load.

[0116] In **FIGS. 1** and **3**, the jugular vein is compressed by the pad **20**. The pad has a predetermined thickness and compressibility. Alternatively, the pads are replaced by inflatable bladders **40**, as shown in **FIG. 2**. A fluid line **46** connects the bladders to a pump **42** and a release valve **44**. The pump **42** can be of the type that is manually squeezed to draw atmospheric air into the bladders. A one-way valve **43** is provided in the fluid line **46** at the pump **42** to maintain the increasing air pressure within the bladders. The pump **42** may be constructed similar to a small engine primer bulb. The pump may be configured to be manually depressed while the collar is being worn. The release valve **44** may be manually activated to relieve the bladder pressure. The release valve may also be configured to automatically vent when a certain pressure is reached to prevent over-inflating the bladders **40**.

[0117] Alternatively the pump **42** may be a microfluidic pump embedded within the strap **32**. The pump may be electrically powered by a battery mounted within the collar or may be remotely powered such as by an RF transmitter placed adjacent the collar. The pump may be remotely controlled by incorporating a transmitter/receiver within the collar. The receiver may transmit pressure data indicating the fluid pressure in the bladders **40** and the receiver can receive remotely generated commands to activate the pump **42** to increase the pressure to an appropriate value. It is further contemplated that the pump **42**, whether manually or electrically operated, may include a pressure gage that is readable on the outside of the collar to assist in inflating the bladders to the desired pressure.

[0118] As illustrated, a collar completely encircles the neck of the subject or, alternatively the compression device may only partially encircle the neck. The device may be a resilient arcuate band having a general C-shape. The band may be formed of a resilient spring-like material with the compression pads mounted to the ends of the C-shape. The device would thus function like a spring clip to exert pressure against the jugular vein. The spring effect of the C-shape can also help hold the device on

the subject's neck, preferably on the back of the neck for better anatomic purchase.

[0119] A compression collar **60**, shown in **FIG. 4**, may incorporate a visual compression indicator that can be visualized when the collar is fitted on a user. The collar **60** includes a strap **62** that may be configured like the straps **12, 32, 52** described above, and may incorporate compression pads **20, 40** arranged to apply pressure to the jugular vein when the strap encircles the neck of the subject. The strap **62** is elastic so that the strap must be elongated or stretched when worn to apply the desired pressure to the IJV. The strap **62** includes an array **65** of stripes **66, 67** of alternating colors. For example, the stripes **66** may be red (to signify a no-go condition) while the stripes **67** may be green (to signify a go condition). The compression collar **60** further includes an overlay **70**, shown in **FIG. 5**, which includes a number of windows **72**. The stripes **66, 67** and windows **72** are in like numbers (four, as illustrated), have the same width and are spaced apart the same dimension. In one specific case the stripes **66, 67** have a width of 2 mm, while the windows **72** have a width of 2 mm and are spaced apart by 2 mm.

[0120] As shown in **FIG. 6**, the overlay **70** is fastened at one end **75** to the strap **62**. The opposite end **76** is not fastened to the strap to thereby permit the strap to stretch beneath the overlay. As described above the entire strap is elastically elongatable. For the compression indicator at least the portion of the strap in the region of the overlay **70** must be elastic and able to elongate or stretch relative to the overlay. The overlay **70** is affixed to the strap **62** so that all or a substantial portion of the "no-go" stripes **66** are visible in the windows **72** when the strap is in its neutral, unstretched configuration (i.e., before the collar is fitted to the subject), as shown in **FIG. 7(a)**. When the collar is fastened around the subject's neck it will stretch and as it stretches the stripes **66, 67** advance relative to the windows **72** of the overlay **70**. Thus, as shown in **FIG. 7(b)**, a portion of both stripes **66, 67** will be visible through the windows. When the strap is stretched a predetermined amount to apply the desired pressure to the IJV, the "go" stripes **67** will be fully or substantially visible in each window **72**, as shown in **FIG. 7(c)**. If the strap is stretched too much, the "no-go" stripes **66** will again be visible in the windows. The compression indicator achieved by the stripe array **65** and overlay **70** thus provides a direct visual indicator as to whether the collar is applying the desired amount of pressure to the IJV. The collar may be adjusted so that the "go" stripes **67** are visible by adjusting the engagement elements, or by using a collar having a different starting length. For instance, for the collar **30** of **FIG. 2**, a different row of snaps **36** may be mated to the snaps **38** to achieve the desired compression.

[0121] In **FIGS. 4-7**, the array **65** includes four sets of parallel stripe pairs **66, 67**. However, other visual indicia in any number of pairs may be utilized with appropriate modifications to the windows **72** of the overlay. For instance, the array **65** may include visual indicia "GO"

and "NOGO" or other words suitable to convey when the collar **60** is applying an appropriate amount of pressure to the IJV. Alternatively, the array may include a single indicia that is visible through a single window in the overlay when the collar is properly adjusted around the neck of the subject. The compression indicator is preferably oriented on the collar at a location that is visible to the subject when looking at a reflective surface. Alternatively, the indicia on the strap **62** may be a tactile indicator that can be felt by the subject's finger through the window(s) in the overlay.

[0122] In accordance with one method, a compression collar, such as the collars **10**, **10'**, **30** and **50** are placed low on the neck of the subject and more particularly between the collar bone and the cricoids cartilage or laryngeal prominence. This location is distant from the carotid sinus which is higher on the neck, so application of pressure to the neck will not compress the carotid artery. In the case of a male subject, the cut-out **14** of the strap **12** is positioned directly beneath the laryngeal prominence.

[0123] The collar may be pre-sized to the subject so that it automatically delivers the proper amount of compression when the ends of the collar are connected. Moreover, as explained above, the engagement elements (i.e., the latching elements **16,18**, the snaps **36, 38**, the hooks **56, 58** or the VELCRO® connection) may be configured to break away or disengage if the pressure exceeds a desired value. This break away feature may also be applied with the pump of **FIG. 2** in which case the bladders **40** can be inflated until the elements become disengaged, at which point the valve **44** may be actuated to bleed off some pressure from the bladders prior to refitting the collar on the subject's neck. As alternative to the pump discussed above in which the pump is provided with a pressure gage, the bladders are inflated to the desired pressure indicated on the gage. In most cases, the desired compression provided by the collar may be in the range of 15-20 mm Hg, although higher pressures are well tolerated and may be indicated for certain subjects.

[0124] It can be appreciated that the collar is only worn when the subject may be exposed to a concussive event, such as a blast during a military battle or hard contact during a sporting activity. Once exposure to such an event ceases the collar may be removed, although it may be beneficial to leave it in place until the subject is evaluated for concussive related trauma.

[0125] Referring now to **FIG. 13**, a single unitary circumferential collar **100** is shown. As the unitary circumferential collar **100** has no means of being opened for placement on the wearer, it is intended that such a collar is made of an elastic material that allows the interior dimension of the collar to expand sufficiently to pass over the head of the wearer.

[0126] Referring now to **FIG. 14**, a circumferential collar type device **102** is shown with pad-like protuberances **103**, and an adjustable fastener **104** (such as a VELCRO® type-connection). The adjustable fastener allows

for proper fit across a range of neck sizes. The collar type device **102** may be made from elastic or inelastic materials.

[0127] Referring now to **FIG. 15**, a similar circumferential collar type device **102** is shown with pad-like protuberances **103**, and an adjustable fastener **104** (such as a VELCRO® type-connection). The adjustable fastener allows for proper fit across a range of neck sizes. The collar type device **102** may be made from elastic or inelastic materials, and further comprises a semi-rigid or rigid laryngeal bridge **105**.

[0128] Referring now to **FIG. 16**, a circumferential collar type device **106** a first piece (i.e., front section **107**) and second piece (i.e., back section **108**). The front section **107** contains two protuberances **103** each configured to apply pressure to a neck vein of a wearer. The back section **108** comprises a fabric collar section **109** configured to be removably attached (such as by VELCRO® type-connections) at either end to corresponding ends **110** and **111** of the front section **107**. It is intended that the back section **108** may be made from elastic or inelastic materials. It is further intended that the front section **107** may further comprise a semi-rigid or rigid laryngeal bridge (not shown).

[0129] Referring now to **FIG. 17** a circumferential collar type device **102** is shown with pad-like protuberances **103**, and an adjustable fastener **104** (such as a VELCRO® type-connection). The adjustable fastener allows for proper fit across a range of neck sizes. The collar type device **102** may be made from elastic or inelastic materials. The two pad-like protuberances **103** each comprise a bladder (not shown) and a pressure release valve **112** configured to apply pressure to a neck vein of a wearer.

[0130] Referring now to **FIG. 18**, a semi-circumferential collar **113** with a front opening is shown. As the semi-circumferential collar **113** is open in the front **114**, it is intended that the collar **113** comprises a rigid or semi-rigid material, and that the collar **113** is worn by sliding the collar onto the neck of the wearer from the back to the front.

[0131] Referring now to **FIG. 19**, a semi-circumferential collar **115** with a back opening **116** is shown. As the semi-circumferential collar **115** is open in the back, it is intended that the collar **115** comprises a rigid or semi-rigid material, and that the collar **115** is worn by sliding the collar onto the neck of the wearer from the front to the back.

[0132] Referring now to **FIGs. 20A-B**, exemplary embodiments that apply pressure on appropriate positions on the neck without the use of a circumferential collar are shown. These embodiments are typically worn as pairs, with a device worn on either side of the neck. **FIG. 20A** shows that each device comprises a pad-type protuberance **103** covered by a flexible material **117** that extends beyond the area defined by the protuberance. If these devices are used without a collar, it is intended that at least a portion of the inwardly directed surface **118** of the material extending beyond the area defined by the pro-

tubercance is coated with an appropriate adhesive. An inwardly directed surface of the protuberance 103 may also be coated with an appropriate adhesive. In these embodiments, the flexible material 118 may be elastic or inelastic. FIG. 20B shows a similar embodiment that differs by employing a resilient arcuate band 119 having a general C, V, or U-shape to form a protuberance 120. As discussed above, the band may be formed of a resilient spring-like material whereby the C, V, or U-shaped band is straightened as the device is applied. After application of the device, spring tension causes compression of the band, resulting in the mid-point or bend-point of the band to extend toward and apply pressure to the neck.

[0133] FIG. 21 is an illustration of another embodiment of the present invention that applies pressure on appropriate positions on the neck without the use of a circumferential collar. The device shown in FIG. 21 is similar to those of FIGs. 20A-B, but further includes a removable tether 121 of the appropriate length between a pair of devices 122. Each device comprises a protuberance 103 and it is intended that one device will be applied to either side of the neck. The removable tether 121 aids in alignment and spacing during application of the devices 122 to the neck.

[0134] FIG. 22 is an illustration of another embodiment of the present invention that applies pressure on appropriate positions on the neck without the use of a circumferential collar. In this embodiment, the device comprises a U-shaped resilient band 123 with a protuberance 103 disposed at or near each end. In some embodiments, the protuberances 103 may be integral to the resilient band 123. The embodiment shown in FIG. 22 is of an alternate design, where the protuberances 103 are integral into devices 122, which are attached at either end of the resilient band 123. The U-shaped resilient band 123 is of the appropriate size and shape, and is appropriately resistant to bending, such that when the band is bent open, the protuberances 103 can be placed on the neck the appropriate locations and the band exerts sufficient compressive force so as to reduce venous blood flow from the head.

[0135] FIG. 23 is an illustration of a non-claimed circumferential collar type device comprising a pull-away cable-tie type ratcheting fit adjustment system. In the shown device, the pull-away cable-tie 124 is configured to release from the collar 125 when pulled at or above a specific pressure, thus ensuring that the collar 125 is not over tightened.

[0136] FIG. 24 is an illustration of a non-claimed circumferential collar type device comprising a rotating ratchet fit adjustment system and an external adjustment tool. The fit of collar 125 is adjusted with an integral cable system 126. An external tool 127 is used to shorten or lengthen the integral cable 126, thereby allowing for fine control of fit adjustment.

[0137] FIG. 25 is an illustration of a non-claimed circumferential collar type device comprising a rotating ratchet fit adjustment system with an integrated adjust-

ment dial. Similar to the case described above, the fit of collar 125 is adjusted with an integral cable system 126. Here, however, an internal ratcheting dial 128 is used to shorten or lengthen the integral cable 126, thereby allowing for fine control of fit adjustment.

[0138] FIG. 26 is an illustration of a non-claimed circumferential collar type device comprising one or more discernible graphic or tactile reference points on an exterior surface of the device to assist placement and/or alignment on the wearer. As described above, the graphic or tactile reference points may be of any suitable design and/or material. In FIG. 26, the graphic or tactile reference points may be placed so as to indicate the mid-point of the device for alignment at the center of the front of the neck (e.g., shown with fabric patch 130), indicate the location of the protuberances (e.g., shown with fabric patches 132), or both (shown with fabric trace 131).

[0139] FIG. 27 is an illustration of a non-claimed device 135 further comprising a sensor (not numbered) configured to detect pulse, blood pressure, or other indicia of proper placement and pressure of a protuberance above a neck vein, and means to transmit a signal from the sensor to an external device 136.

[0140] In FIG. 28 one or more protuberances 103 are integral with a non-claimed garment 137. The protuberances 103 may be incorporated into a portion of a garment 138 that covers a portion of the neck of a wearer. Preferably, the portion of the garment 138 covering the portion of the neck of the wearer comprises an elastic material such that the collar of the garment exerts sufficient pressure on the protuberances 103 so as to reduce venous blood flow from the head. While not intending to be limiting, it is envisioned that garments designed for various specialized purposes, such as components of military uniforms or sporting apparel, may be constructed according to these embodiments.

[0141] In accordance with various embodiments, a device for applying pressure to one or more neck veins of a subject is disclosed, comprising:

a flexible material sized to cover a minority of the circumference of the neck of a subject; and
one or more inwardly directed protuberances contacting an inner surface of said flexible material;

wherein the flexible material is sized such that an inner surface of said material extends beyond the protuberance, and said protuberances are of appropriate size and shape such that when placed on the neck above a neck vein of the subject, said device restricts blood flow egressing from the head of the subject.

[0142] Some embodiments of the device for applying pressure to one or more neck veins of a subject comprise a resilient arcuate band having a general C, V, or U-shape and sized to encircle a minority of the neck of a subject, and one or more inwardly directed protuberances, wherein said resilient arcuate band is configured to apply pressure to said one or more protuberances to restrict blood

flow egressing from the head of the subject when applied to the neck of a subject.

[0143] In further embodiments of the device of the aforementioned kind said protuberance may be defined by the outward bend point of a resilient arcuate band having a general C, V, or U-shape.

[0144] In further embodiments of the device of the aforementioned kind a portion of said material that extends beyond the protuberance may be coated with an adhesive.

[0145] In further embodiments of the device of the aforementioned kind said flexible material may be an elastic material.

[0146] In further embodiments of the device of the aforementioned kind said flexible material may be an in-elastic material.

[0147] According to further embodiments, a system for applying pressure to one or more neck veins of a subject is disclosed, comprising two devices of the aforementioned kind attached to each other by a removable tether; wherein said removable tether is sized to facilitate appropriate spacing and alignment during application to the neck of a subject.

[0148] In further embodiments of the system of the aforementioned kind said neck veins may include the internal jugular vein or the external jugular vein.

[0149] In further embodiments of the system of the aforementioned kind said system may restrict blood flow egressing from the head of the subject wearing the device sufficiently to reduce the likelihood of injury in a subject exposed to an external concussive force relative to a subject not wearing the system.

[0150] In further embodiments of the system of the aforementioned kind said injury may be selected from the group consisting of traumatic brain injury, spinal column injury, inner ear injury, ocular structure injury, and olfactory center injury.

[0151] In further embodiments of the system of the aforementioned kind said one or more protuberances may exert a pressure on said one or more neck veins equivalent to a fluid pressure within the range of 1 mmHg to about 70 mmHg.

[0152] In further embodiments of the system of the aforementioned kind said one or more protuberances may exert a pressure on said one or more neck veins equivalent to a fluid pressure within the range of 5 mmHg to about 25 mmHg.

Example 1

[0153] *Materials and Methods:* Two groups of ten (total of 20) male Sprague-Dawley rats weighing between 350 and 400 grams were used. Animals were housed under 12 hour light/12 hour dark conditions with rat chow and water available *ad libitum*.

[0154] *Marmarou impact acceleration injury model in rats:* Anesthesia was induced and maintained with isoflurane using a modified medical anesthesia machine.

Body temperature was controlled during the approximately 10 min. procedures using a homeothermic heating blanket with rectal probe, and adequate sedation was confirmed by evaluation of response to heel tendon pinch. The animals were shaved and prepared in sterile fashion for surgery, followed by subcutaneous injection of 1% lidocaine local anesthetic into the planned incision site. A 3 cm midline incision in the scalp was made and periosteal membranes separated, exposing bregma and lambda. A metal disk 10 mm in diameter and 3 mm thick was attached to the skull with cyanoacrylate and centered between bregma and lambda.

[0155] The animal was placed prone on a foam bed with the metal disk directly under a Plexiglas tube. A 450-g brass weight was dropped a single time through the tube from a height of 2 meters, striking the disk. The animal was then ventilated on 100% oxygen while the skull was inspected, the disk removed, and the incision repaired. When the animal recovered spontaneous respirations, anesthesia was discontinued and the animal was returned to its cage for post-operative observation. Buprenorphine was used for post-operative analgesia.

Illustrative Example 2

[0156] *Experimental protocol:* This work involved two groups, each consisting of 10 animals for a total of 20 animals. Two groups were utilized, a control injury group and an experimental injury group. In the experimental injury group the rats were fitted with a 15 mm wide collar, with two compressive beads designed to overlay the IJVs and was tightened sufficiently to provide mild compression of the veins without compromising the airway. The collar was then fixed in circumference with a Velcro® fastener. The collar was left in position for three minutes prior to administering experimental brain injury.

[0157] *Assessment of Intracranial Reserve Volume Intracranial Pressure (ICP) Measurement:* ICP was measured in five animals using the FOP-MIV pressure sensor (FISO Technologies, Quebec, Canada) as described by Chavko, *et al.* The head of the rat was shaved and prepped in sterile fashion for surgery. The rat was fixed in a stereotaxic apparatus (model 962; Dual Ultra Precise Small Animal Stereotaxic Instrument, Kopf Instruments, Germany) and a 3 cm mid-line incision in the scalp was made. Periosteal membranes were separated, exposing both bregma and lambda. A 2 mm burr hole was drilled 0.9 mm caudal from bregma and 1.5 mm from the midline. The fiber optic probe was then inserted to a depth of 3 mm into the cerebral parenchyma.

[0158] *Intraocular Pressure (IOP) Measurement:* IOP was measured in all animals using the TonoLab rebound tonometer (Colonial Medical Supply, Franconia, NH) as described in the literature, IOP measurements were taken after induction of anesthesia in all animals and a second time in the experimental group following application of the UV compression device. Following application of the IJV compression device in the experimental injury

group, IOP readings were taken every 30 secs while the compression device was in place.

[0159] *Tissue Preparation and Immunohistochemical Labeling:* At 7 days post-injury all animals (n=20) were anesthetized and immediately perfused transcardially with 200 ml cold 0.9% saline to wash out all blood. This was followed by 4% paraformaldehyde infusion in Millings buffer for 40 mins. The entire brain, brainstem, and rostral spinal cord were removed and immediately placed in 4% paraformaldehyde for 24 hours. Following 24 hours fixation, the brain was blocked by cutting the brainstem above the pons, cutting the cerebellar peduncles, and then making sagittal cuts lateral to the pyramids. The resulting tissue, containing the corticospinal tracts and the medial lemnisci, areas shown previously to yield traumatically injured axons, was then sagittally cut on a vibratome into 50 micron thick sections.

[0160] The tissue underwent temperature controlled microwave antigen retrieval using previously described techniques. The tissue was pre-incubated in a solution containing 10% normal serum and 0.2% Triton X in PBS for 40 mins. For amyloid precursor protein (APP) labeling, the tissue was incubated in polyclonal antibody raised in rabbit against beta APP (#51-2700, Zymed, Inc., San Francisco, CA) at a dilution of 1:200 in 1% NGS in PBS overnight. Following incubation in primary antibody, the tissue was washed 3 times in 1% NGS in PBS, then incubated in a secondary anti-rabbit IgG antibody conjugated with Alexa 488 fluorophore (Molecular Probes, Eugene, OR), diluted at 1:200 for two hours. The tissue underwent a final wash in 0.1M phosphate buffer, and then was mounted using an antifade agent and coverslipped. The slides were sealed with acrylic and stored in the dark in a laboratory refrigerator.

[0161] *Fluorescent Microscopy and Image analysis:* The tissue was examined and images acquired using a Olympus AX70 fluorescence microscope system (Olympus; Tokyo, Japan). Ten digital images were obtained from the tissue of each animal and images were then randomized. Individual injured axons were independently counted and data was stored in a spreadsheet (Microsoft Corp., Redmond, WA). Differences between group means were determined using paired t-tests and considered significant if the probability value was less than 0.05.

[0162] *Stereological Quantification of axonal injury:* A stereological method was used to determine an unbiased estimate of the number of APP positive axons per cubic mm in the corticospinal tract and medial lemniscus. The optical fractionator technique utilizing a Stereoinvestigator 9.0 (MBF Bioscience, Inc., Williston, VT) and a Olympus AX70 microscope with 4x and 40x objectives was performed. Sagittal APP stained specimens were examined with low magnification and regions of interest were drawn incorporating the corticospinal tract and medial lemniscus. The software then selected random 50 micron counting frames with depth of 15 microns, and APP positive axons were marked. The volume of the region of interest (ROI) was determined using the Cavalieri

method, the volume of the sum of the counting frames was calculated, the sum total of injured axons within the counting frames was calculated, and an estimate of the number of APP positive axons per cubic mm was calculated.

Illustrative Example 3

[0163] *Volume Intracranial Pressure (ICP) Measurement:* ICP was assessed both prior to and after application of the IJV compression device. The baseline ICP was 10.23 ± 1.68 mm Hg and was increased to 16.63 ± 2.00 mm Hg following IJV compression (**FIG. 8:** $p < 0.01$). Notably, this increase of greater than 30% from baseline occurred within seconds following IJV compression. Intraocular Pressure (IOP) Measurement: IOP measurements were taken both before and after application of the IJV compression device, similar to ICP recordings. The baseline IOP was 11.18 ± 2.27 mm Hg and was elevated to 16.27 ± 3.20 mm Hg following IJV compression (**FIG. 9:** $p < 0.01$).

[0164] The increase of 31% seen in IOP following IJV compression is strikingly similar to that seen in ICP following IJV compression, both in magnitude and rapidity of response (**FIG. 10**).

[0165] *TBI- Impact Acceleration Model:* None of the animals died from the head trauma. Animals tolerated collar application without any observed untoward effects for the duration of the experiment. Specifically, there were no outward or visible signs of discomfort, intolerance, or respiratory difficulty. All recovered without complication and exhibited normal behavioral and feeding habits up until the day of sacrifice. At necropsy, the brains were grossly normal in appearance.

[0166] *Stereologic Analysis of APP Positive Axons:* To determine the density of injured axons in the corticospinal tracts and medial lemnisci, the stereological optical fractionator method was used. Compared to the normal anatomy found in previous experiments with sham animals, control animals without the collar demonstrated focal labeling of APP within many swollen contiguous and terminal axon segments, consistent with impaired axoplasmic transport in traumatic axonal injury. Following microscopic digital image acquisition from multiple areas within the corticospinal tract and medial lemnisci from multiple tissue slices, counting of APP positive axons in animals who received the IJV compression collar demonstrated much fewer APP positive axons, at a frequency much more similar to sham animals, compared to those undergoing injury without UV compression (Figs. 4A and 4B). These abnormal axons demonstrated typical morphological characteristics of traumatic injury, primarily swelling and disconnection. By qualitative analysis, the experimental group showed ($m \pm sd$) $13,540 \pm 9808$ vs. $77,474 \pm 25,325$ ($p < 0.01$) APP positive axons/ mm^3 in the control group (**FIG. 12**).

Example 4

[0167] Two groups of 10 adult male Sprague-Dawley rats were subjected to an impact acceleration traumatic brain injury. Prior to the injury, the experimental group had application of a 15 mm wide cervical collar, which had two compressive beads over the internal jugular veins (IJVs). The control group had the experimental injury only. Intracranial pressure (ICP) and intraocular pressure (IOP) were measured before and after IJV compression to assess collar performance. All rats were sacrificed after a 7-day recovery period, and brainstem white matter tracts underwent fluorescent immunohistochemical processing and labeling of beta amyloid precursor protein (APP), a marker of axonal injury. Digital imaging and statistical analyses were used to determine if IN compression resulted in a diminished number of injured axons.

Example 5

[0168] All animals survived the experimental paradigm and there were no adverse reactions noted following application of the collar. In the experimental group, IJV compression resulted in an immediate and reversible elevation of ICP and IOP, by approximately 30%, demonstrating physiologic changes secondary to collar application. Most notably, quantitative analysis showed 13,540 APP positive axons in the experimental group versus 77,474 in the control group ($p < 0.0$), a marked reduction of greater than 80%.

[0169] Using a standard acceleration-deceleration impact laboratory model of mild TBI, a reduction of axonal injury following IJV compression as indicated by immunohistochemical staining of APP was shown. IJV compression reduces SLOSH-mediated brain injury by increasing intracranial blood volume and reducing the compliance and potential for brain movement within the confines of the skull.

Example 6

[0170] *Internal versus External Brain Protection:* Compression of the IJV for 3 min prior to head trauma led to physiological alterations in intracranial compliance, as evidenced by modest increases in ICP and IOP, while simultaneously and markedly reducing the pathologic index of primary neuronal injury in the standardized rat model of TBI. Reduction in brain volume compliance could prevent the differential motions between the cranium and the brain that lead to energy absorption and neuronal primary and secondary injuries. These pathological changes include axonal tearing that disrupt axoplasmic transport resulting in axonal swelling and activation of the apoptotic cascades, as evidenced in this model by a statistically significant reduction in APP counts of injured axons.

[0171] In the animal model of the present disclosure,

applying the collar increased ICP and IOP by 30% and 31%, respectively. The effect of compression of jugular veins on ICP is clinically well known. The Queckenstadt test is used to indicate the continuity of CSF between the skull and spinal cord. In this test, ICP is increased by compression of the IJVs while the CSF pressure is measured in the spine through a lumbar puncture. Increases in ICP have also been shown to occur with placement of tight fitting neck stabilization collars that likely compress the IJVs. Compression of the IJVs, which can occur when wearing shirts with tight collars or neckties, has also been shown to increase IOP. Notably, only mild compressive pressure is required to partially occlude the IJVs as they are a low pressure system. As the inflow of cerebral arterial blood continues after partial cerebral venous outlet obstruction, the intracerebral and venous pressure increases until the jugular venous resistance is overcome or the blood drainage is redirected to other venous channels. In either case there is a reduction in intracranial compliance and a modest increase in ICP.

[0172] The immunohistochemical assay used in the studies of the present disclosure is specific for axonal damage and results in a reliable range of measured damaged neurons. In addition, the Marmarou model of acceleration-deceleration injury is an accepted and well-studied methodology by which to quantify the extent of TBI. The reduction in damaged axons, as evidenced by a marked reduction in APP counts, in the experimental group with the IJV compression device is highly statistically significant ($p < 0.01$). Additionally, the change in ICP was measured after applying the collar in five rats. The results show that every study rat had a reduction in axonal injury greater than the 95% confidence interval of the control group.

Claims

1. A device for applying pressure to one or more neck veins of a subject comprising:

a flexible material (117) sized to cover a minority of the circumference of the neck of a subject; and one or more inwardly directed protuberances (103, 120) contacting an inner surface (118) of said flexible material (117);

wherein the flexible material (117) is sized such that an inner surface (118) of said material extends beyond the protuberance (103, 120), and said protuberances are of appropriate size and shape such that when placed on the neck above a neck vein of the subject, said device restricts blood flow egressing from the head of the subject and wherein the device is of a non-collar type.

2. The device of claim 1, wherein said protuberance is defined by an outward bend point (120) of a resilient

arcuate band (119) having a general C, V, or U-shape

3. The device of claim 1 or 2, wherein a portion of said material (117) that extends beyond the protuberance (103, 120) is coated with an adhesive.
4. The device of any one of claims 1 to 3, wherein said neck vein includes the internal jugular vein or the external jugular vein.
5. The device of any one of claims 1 to 4, wherein said one or more protuberances (103, 120) exerts a pressure on said one or more neck veins equivalent to a fluid pressure within the range of 1 mmHg to about 70 mmHg.
6. The device of claim 5, wherein said one or more protuberances (103, 120) exerts a pressure on said one or more neck veins equivalent to a fluid pressure within the range of 5 mmHg to about 25 mmHg.
7. A system for applying pressure to two or more neck veins of a subject comprising a pair of devices (122) according to any one of claims 1-6 attached to each other by a removable tether (121) sized to facilitate spacing and alignment of each device (122) over a neck vein during application to the neck of a subject.
8. The system of claim 7, wherein each of said devices (122) is adapted to exert a pressure on said two or more neck veins equivalent to a fluid pressure within the range of 5 mmHg to about 70 mmHg.
9. The system of claim 7 or 8, wherein the removable tether (121) is sized to facilitate alignment of each device (122) over an external jugular vein.
10. The system of claim 7 or 8, wherein the removable tether (121) is sized to facilitate alignment of each device over an internal jugular vein.
11. Method for applying pressure to one or more neck veins of a subject, the method comprising:
 - contacting one or more protuberances (103, 120) of a device of any one of claims 1 to 6 to the neck of the subject, wherein each protuberance (103, 120) is located above one or more neck veins of the subject; and
 - applying localized pressure by means of the protuberances (103, 120) to the one or more neck veins sufficient to restrict blood flow egressing from the head of the subject through the one or more neck veins.
12. Method of claim 11, wherein the device is applied to an internal jugular

vein and/or external jugular vein.

13. Method of claim 11 or 12, wherein the device applies a pressure of a fluid pressure within the range of 1 mmHg to about 70 mmHg.

Patentansprüche

1. Vorrichtung zum Applizieren eines Druckes auf mindestens eine Halsvene einer Person, aufweisend:
 - ein flexibles Material (117), welches größenmäßig so ausgebildet ist, dass es eine Minderheit des Umfangs des Halses einer Person abdeckt; mindestens einen nach innen gerichteten Vorsprung (103, 120), welcher eine Innenfläche (118) des flexiblen Materials (117) berührt; wobei das flexible Material (117) größenmäßig derart ausgebildet ist, dass sich eine Innenfläche (118) des flexiblen Materials über den Vorsprung (103, 120) hinaus erstreckt, und der mindestens eine Vorsprung (103, 120) größenmäßig und von der Form her so ausgebildet ist, dass er den aus dem Kopf der Person austretenden Blutfluss einschränkt wenn er auf dem Hals über einer Halsvene der Person platziert wird und wobei es sich bei der Vorrichtung nicht um eine halsbandartige Vorrichtung handelt.
2. Vorrichtung nach Anspruch 1, wobei der Vorsprung durch einen äußeren Biegepunkt (120) eines elastischen bogenförmigen Bandes (119) vorgegeben ist, welches eine generelle C-, V- oder U-Form aufweist.
3. Vorrichtung nach Anspruch 1 oder 2, wobei ein Abschnitt des Materials (117), welcher sich über den Vorsprung (103, 120) hinaus erstreckt, mit einem Klebstoff beschichtet ist.
4. Vorrichtung nach einem der Ansprüche 1 bis 3, wobei die Halsvene die innere oder die externe Jugularvene umfasst.
5. Vorrichtung nach einem der Ansprüche 1 bis 4, wobei der mindestens eine Vorsprung (103, 120) einen Druck auf die mindestens eine Halsvene ausübt, welcher äquivalent ist zu einem Fluiddruck innerhalb eines Bereiches von 1 mmHg bis ungefähr 70 mmHg.
6. Vorrichtung nach Anspruch 5, wobei der mindestens eine Vorsprung (103, 120) einen Druck auf die mindestens eine Halsvene ausübt, welcher äquivalent ist zu einem Fluiddruck innerhalb eines Bereiches von 5 mmHg bis ungefähr 25 mmHg.
7. Ein System zum Applizieren eines Druckes auf min-

- destens eine Halsvene einer Person aufweisend ein Paar von Vorrichtungen (122) gemäß einem der Ansprüche 1 bis 6, welche mittels eines entfernbaren Haltelements (121) miteinander verbunden sind, welches großemäßig so ausgebildet ist, dass es das Beabstanden und Ausrichten jeder der Vorrichtungen (122) über eine Halsvene während einer Anbringung an den Hals einer Person erleichtert.
- 5
8. System nach Anspruch 7, wobei jede der Vorrichtungen (122) eingerichtet ist einen Druck auf die mindestens zwei Halsvenen auszuüben, welcher äquivalent ist zu einem Fluiddruck innerhalb eines Bereiches von 5 mmHg bis ungefähr 70 mmHg.
- 10
9. System nach Anspruch 7 oder 8, wobei das entfernbare Haltelement (121) großemäßig so ausgebildet ist, dass es das Ausrichten jeder Vorrichtung (122) über einer externen Jugularvene erleichtert.
- 15
10. System nach Anspruch 7 oder 8, wobei das entfernbare Haltelement (121) großemäßig so ausgebildet ist, dass es das Ausrichten jeder der Vorrichtungen (122) über einer internen Jugularvene erleichtert.
- 20
11. Verfahren zum Applizieren eines Druckes auf mindestens eine Halsvene einer Person, wobei das Verfahren aufweist:
- 25
- Anbringen mindestens eines Vorsprungs (103, 120) einer Vorrichtung gemäß einem der Ansprüche 1 bis 6 an den Hals einer Person, wobei jeder Vorsprung (103, 120) über mindestens einer Halsvene der Person angeordnet ist; und Applizieren eines lokalisierten Druckes mittels der Vorsprünge (103, 120) auf mindestens eine Halsvene welcher ausreicht, um den aus dem Kopf der Person durch die mindestens eine Halsvene austretenden Blutfluss einzuschränken.
- 30
12. Verfahren nach Anspruch 11, wobei die Vorrichtung auf eine interne Jugularvene und/oder eine externe Jugularvene aufgebracht wird.
- 35
13. Verfahren nach Anspruch 11 oder 12, wobei die Vorrichtung einen Druck ausübt, welcher einem Fluiddruck entspricht innerhalb eines Bereiches von 1 mmHg bis ungefähr 70 mmHg.
- 40
- 45
- 50
- 55
- un matériau souple (117) dimensionné pour recouvrir une partie minoritaire de la circonférence du cou d'un sujet ; et une ou plusieurs protubérances (103, 120) orientées vers l'intérieur, venant en contact avec une surface intérieure (118) dudit matériau souple (117) ;
- dans lequel ledit matériau souple (117) est dimensionné de telle sorte qu'une surface intérieure (118) dudit matériau s'étende au-delà de la protubérance (103, 120), et lesdites protubérances sont d'une taille et d'une forme appropriées pour que, lorsqu'elles sont placées sur le cou au-dessus d'une veine du cou du sujet, ledit dispositif restreigne l'écoulement sanguin quittant la tête du sujet et dans lequel le dispositif n'est pas du type collier.
2. Dispositif selon la revendication 1, dans lequel ladite protubérance est définie par un point de courbure vers l'extérieur (120) d'une bande arquée élastique (119) présentant une forme globale en C, V ou U.
3. Dispositif selon la revendication 1 ou 2, dans lequel une partie dudit matériau (117) qui s'étend au-delà de la protubérance (103, 120) est recouverte d'un adhésif.
4. Dispositif selon l'une quelconque des revendications 1 à 3, dans lequel ladite veine du cou comprend la veine jugulaire interne ou la veine jugulaire externe.
5. Dispositif selon l'une quelconque des revendications 1 à 4, dans lequel ladite ou lesdites protubérances (103, 120) exercent une pression sur ladite ou lesdites veines du cou équivalente à une pression de fluide dans la plage de 1 mmHg à environ 70 mmHg.
6. Dispositif selon la revendication 5, dans lequel ladite ou lesdites protubérances (103, 120) exercent une pression sur ladite ou lesdites veines du cou équivalente à une pression de fluide dans la plage de 5 mmHg à environ 25 mmHg.
7. Système permettant d'appliquer une pression à au moins deux veines du cou d'un sujet, comprenant une paire de dispositifs (122) selon l'une quelconque des revendications 1 à 6 attachés l'un à l'autre par un élément de fixation amovible (121) dimensionné de façon à faciliter l'espacement et l'alignement de chaque dispositif (122) vis-à-vis d'une veine du cou lors de l'application sur le cou d'un sujet.
8. Système selon la revendication 7, dans lequel chacun desdits dispositifs (122) est conçu pour exercer une pression sur lesdites au moins deux veines du cou équivalente à une pression de fluide dans la plage de 5 mmHg à environ 70 mmHg.

Revendications

1. Dispositif servant à appliquer une pression à une ou plusieurs veines du cou d'un sujet comprenant :

9. Système selon la revendication 7 ou 8, dans lequel l'élément de fixation amovible (121) est dimensionné de façon à faciliter l'alignement de chaque dispositif (122) vis-à-vis d'une veine jugulaire externe. 5
10. Système selon la revendication 7 ou 8, dans lequel l'élément de fixation amovible (121) est dimensionné de façon à faciliter l'alignement de chaque dispositif vis-à-vis d'une veine jugulaire interne. 10
11. Procédé d'application d'une pression à une ou plusieurs veines du cou d'un sujet, le procédé comprenant :
- mettre une ou plusieurs protubérances (103, 120) d'un dispositif selon l'une quelconque des revendications 1 à 6 en contact avec le cou du sujet, chaque protubérance (103, 120) étant située au-dessus d'une ou plusieurs veines du cou du sujet ; et 15
- appliquer, au moyen des protubérances (103, 120), une pression localisée sur la ou les veines du cou, suffisante pour restreindre l'écoulement sanguin quittant la tête du sujet par la ou les veines du cou. 20
12. Procédé selon la revendication 11, dans lequel le dispositif est appliqué à une veine jugulaire interne et/ou une veine jugulaire externe. 25
13. Procédé selon la revendication 11 ou 12, dans lequel le dispositif applique une pression d'une pression de fluide dans la plage de 1 mmHg à environ 70 mmHg. 30

35

40

45

50

55

Figure 1

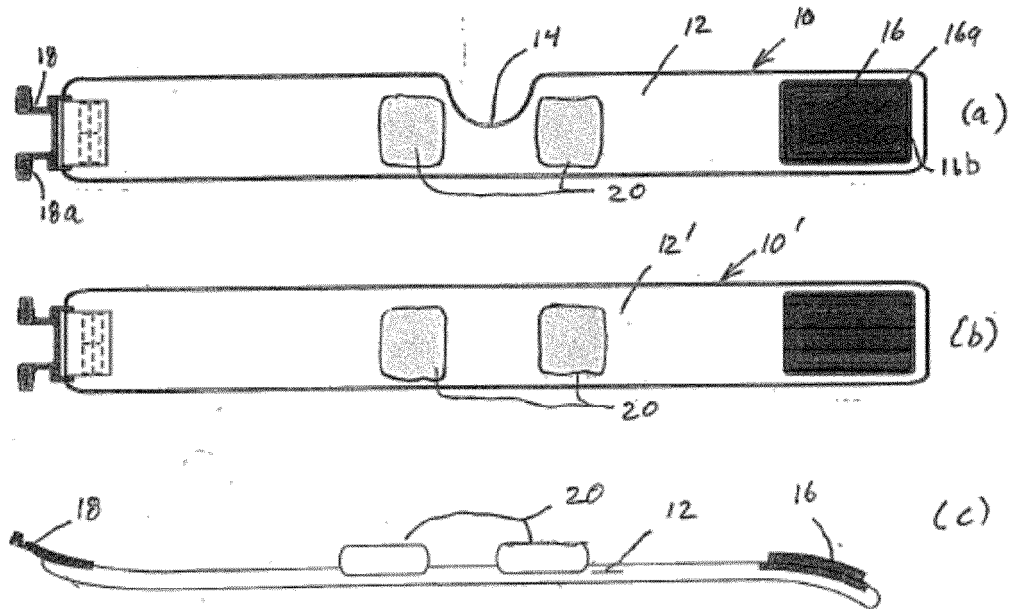

Figure 2

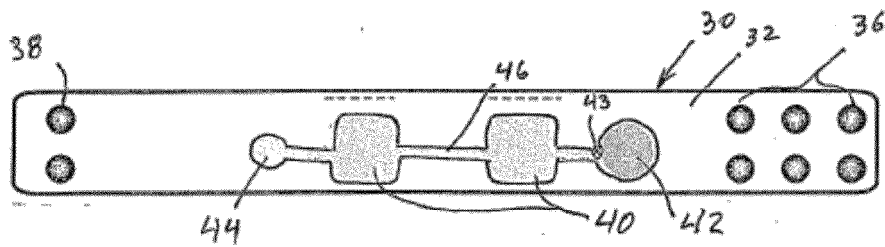

Figure 3

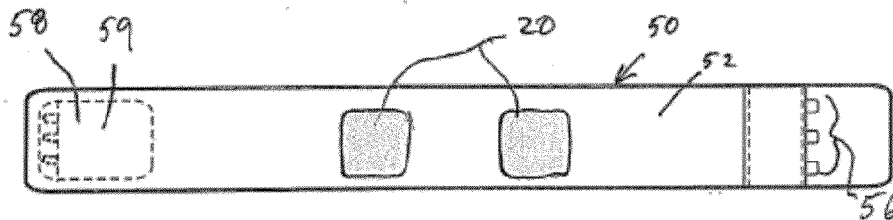

Figure 4

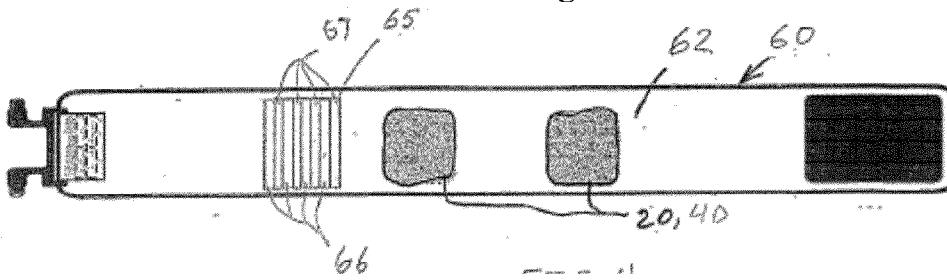

Figure 5

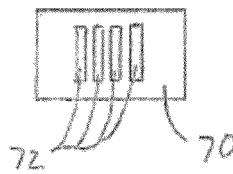

Figure 6

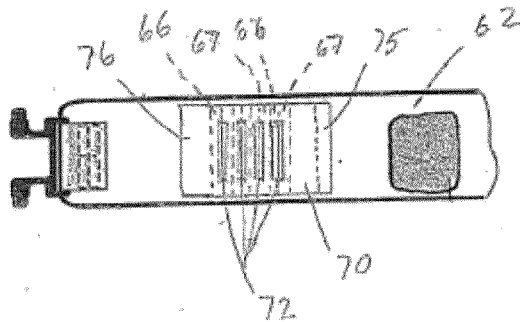

Figure 7

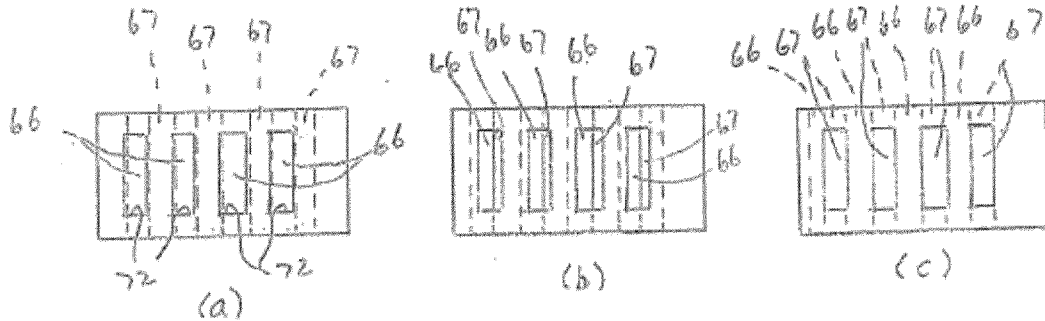

Figure 8

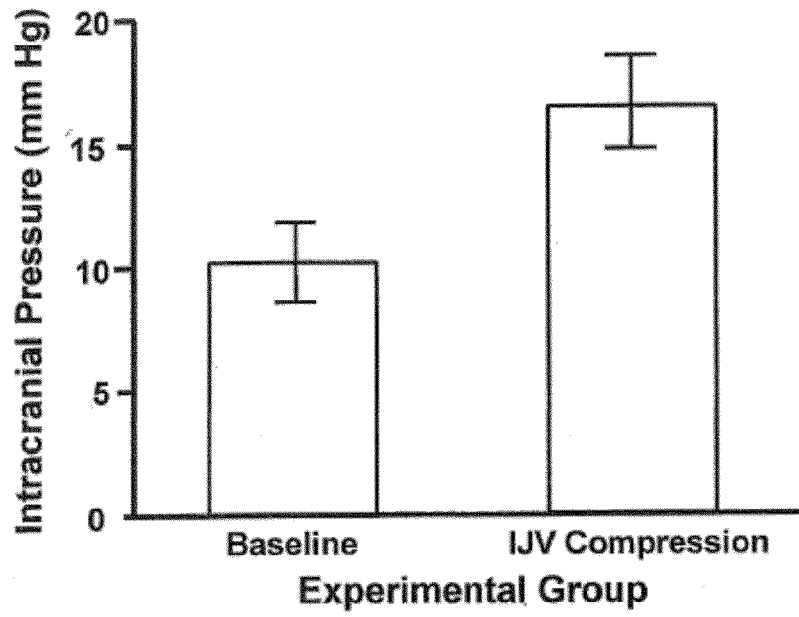

Figure 9

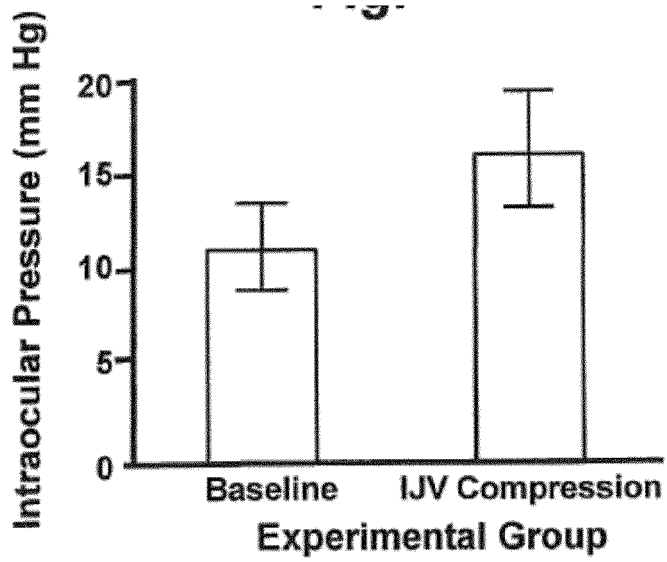

Figure 10

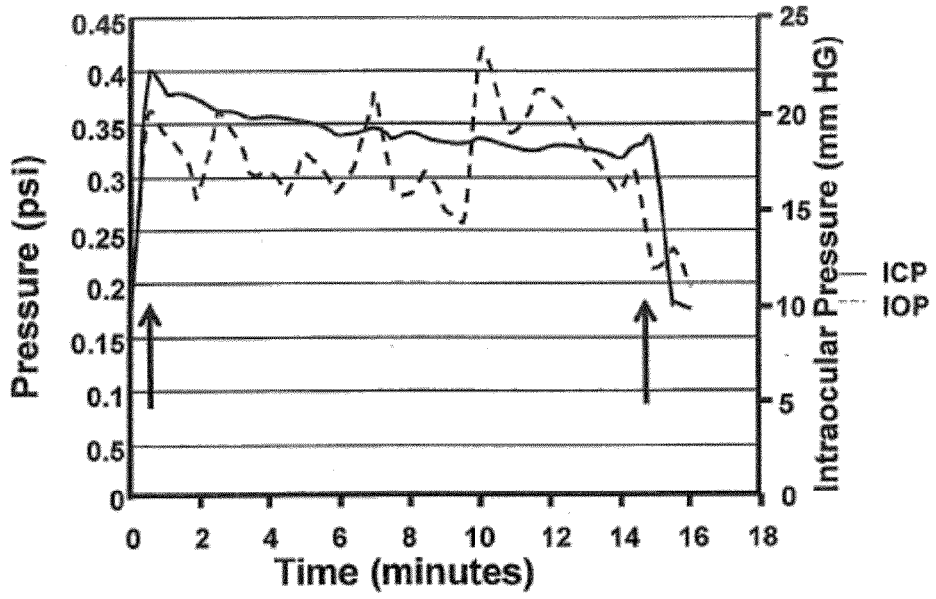

Figure 11A

Figure 11B

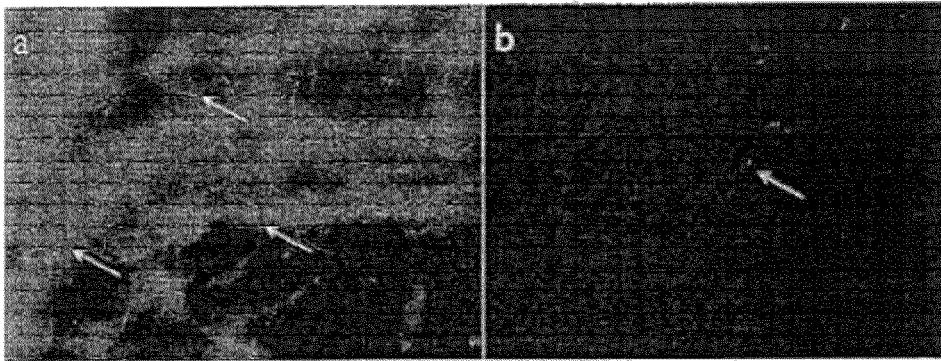

Figure 12

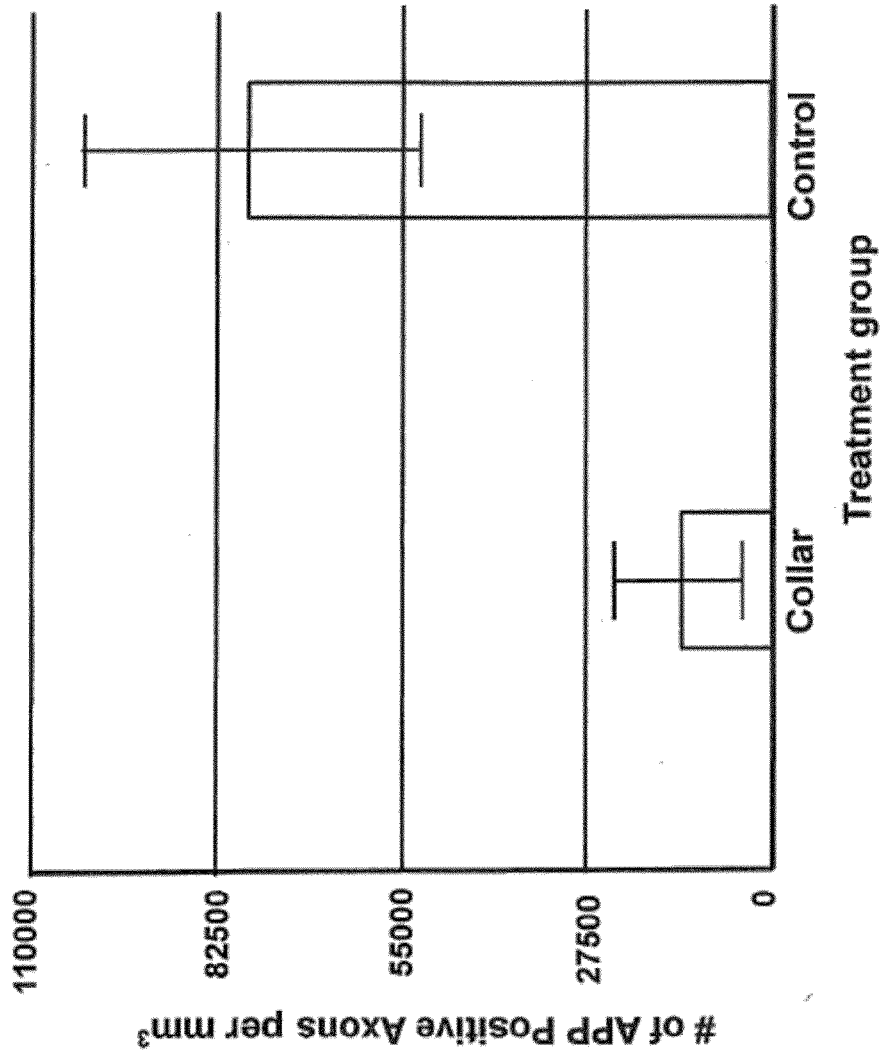

Figure 13

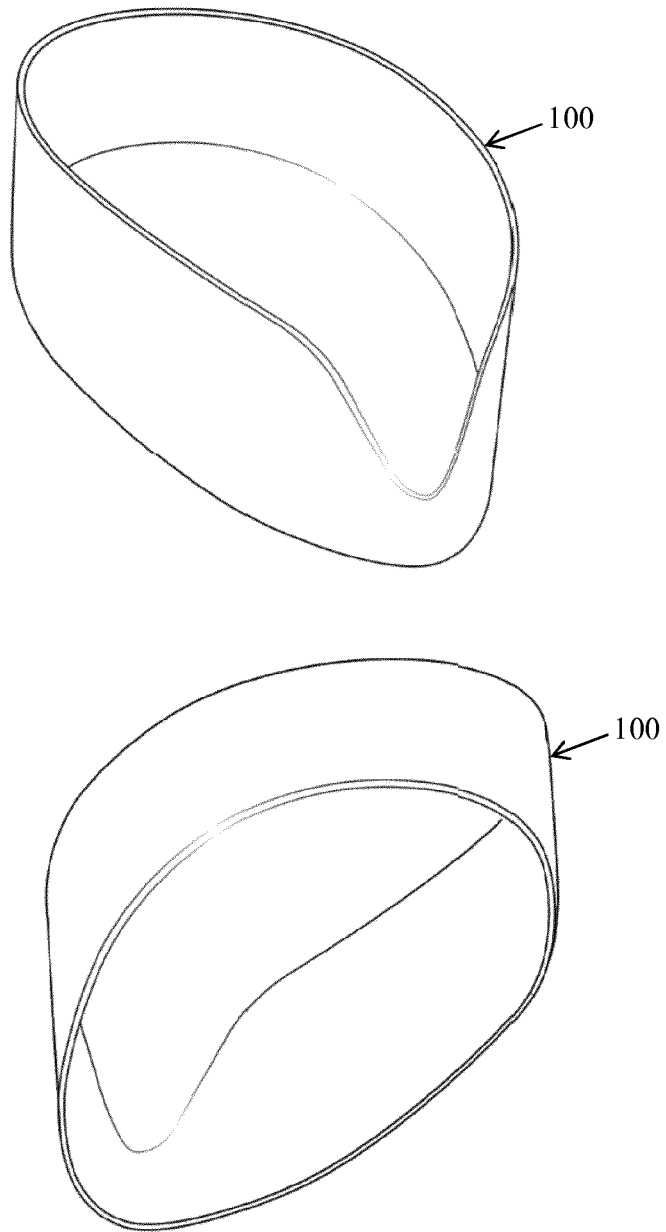

Figure 14

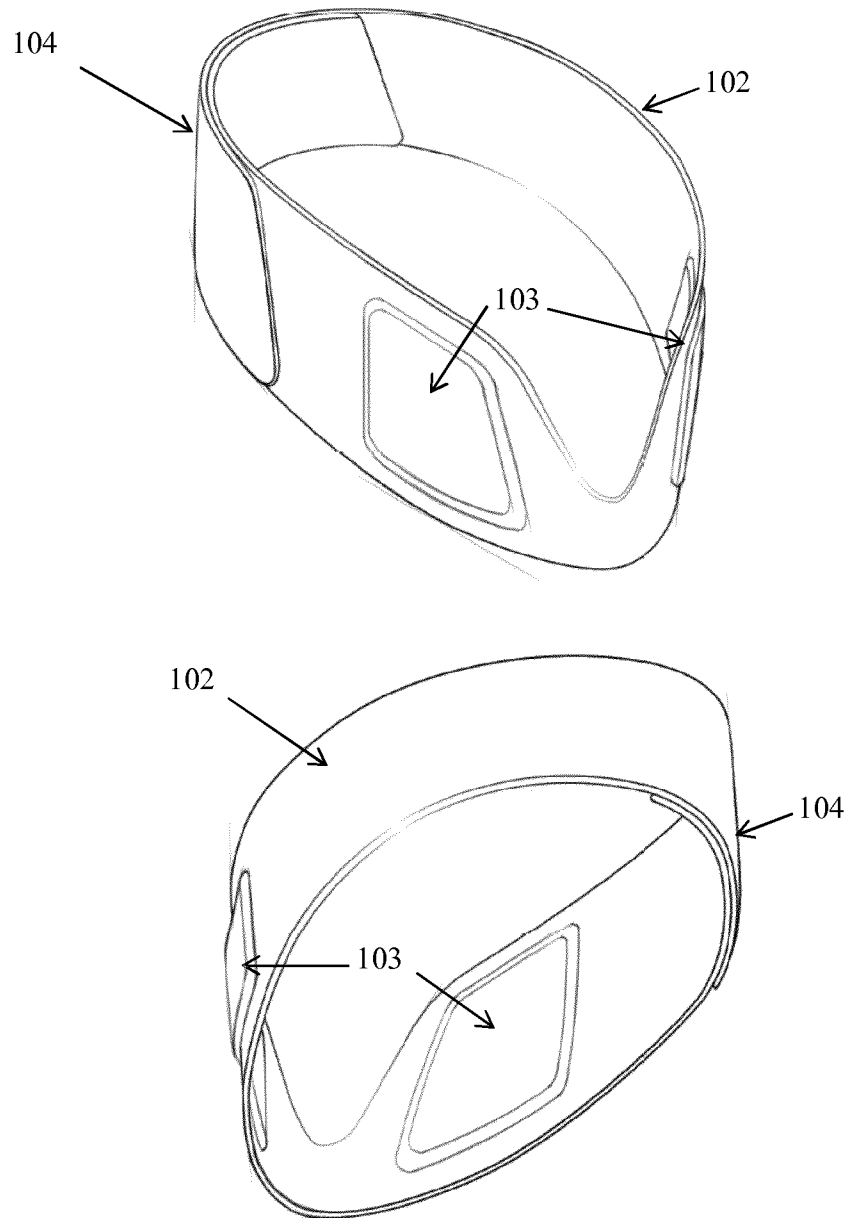

Figure 15

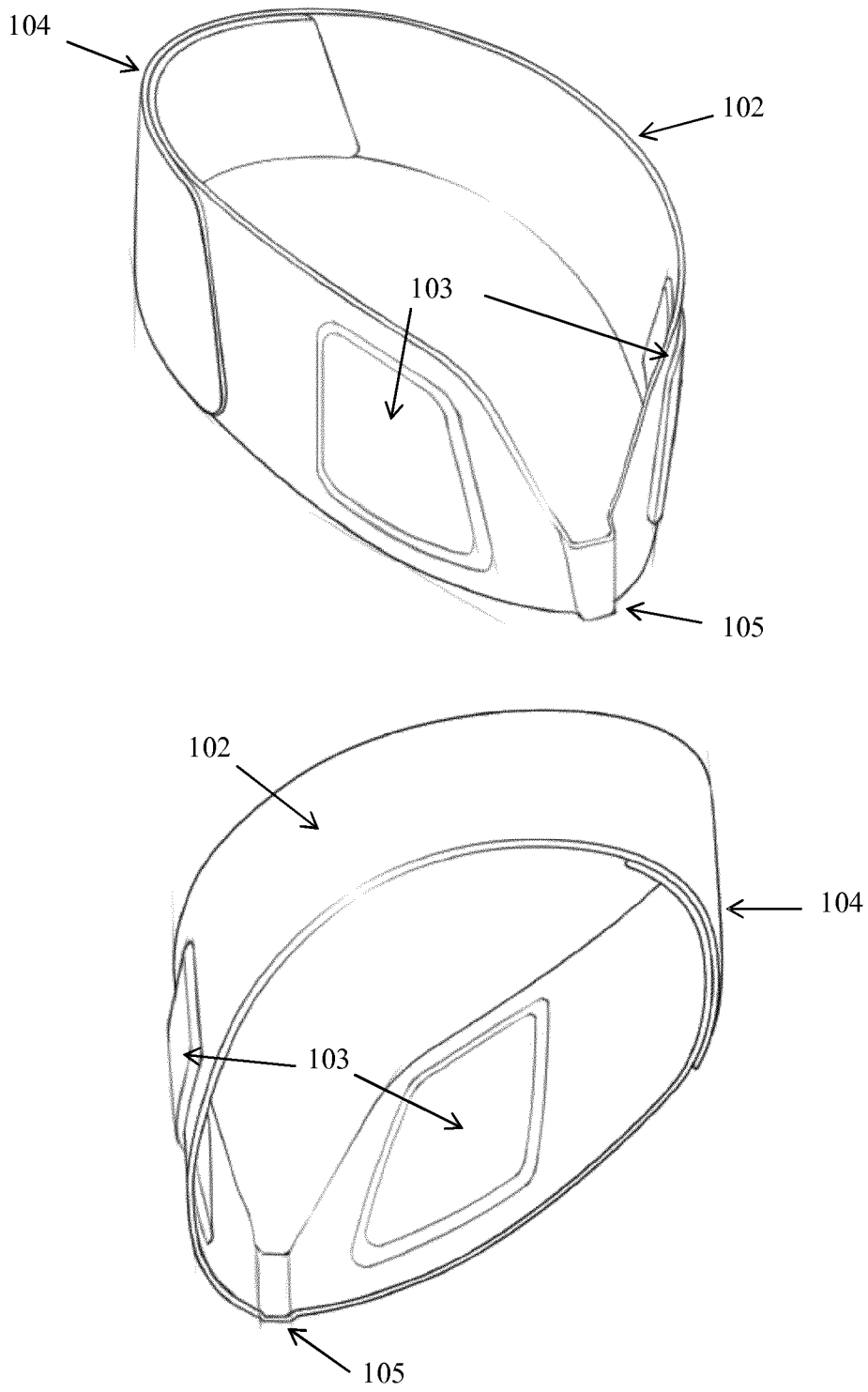

Figure 16

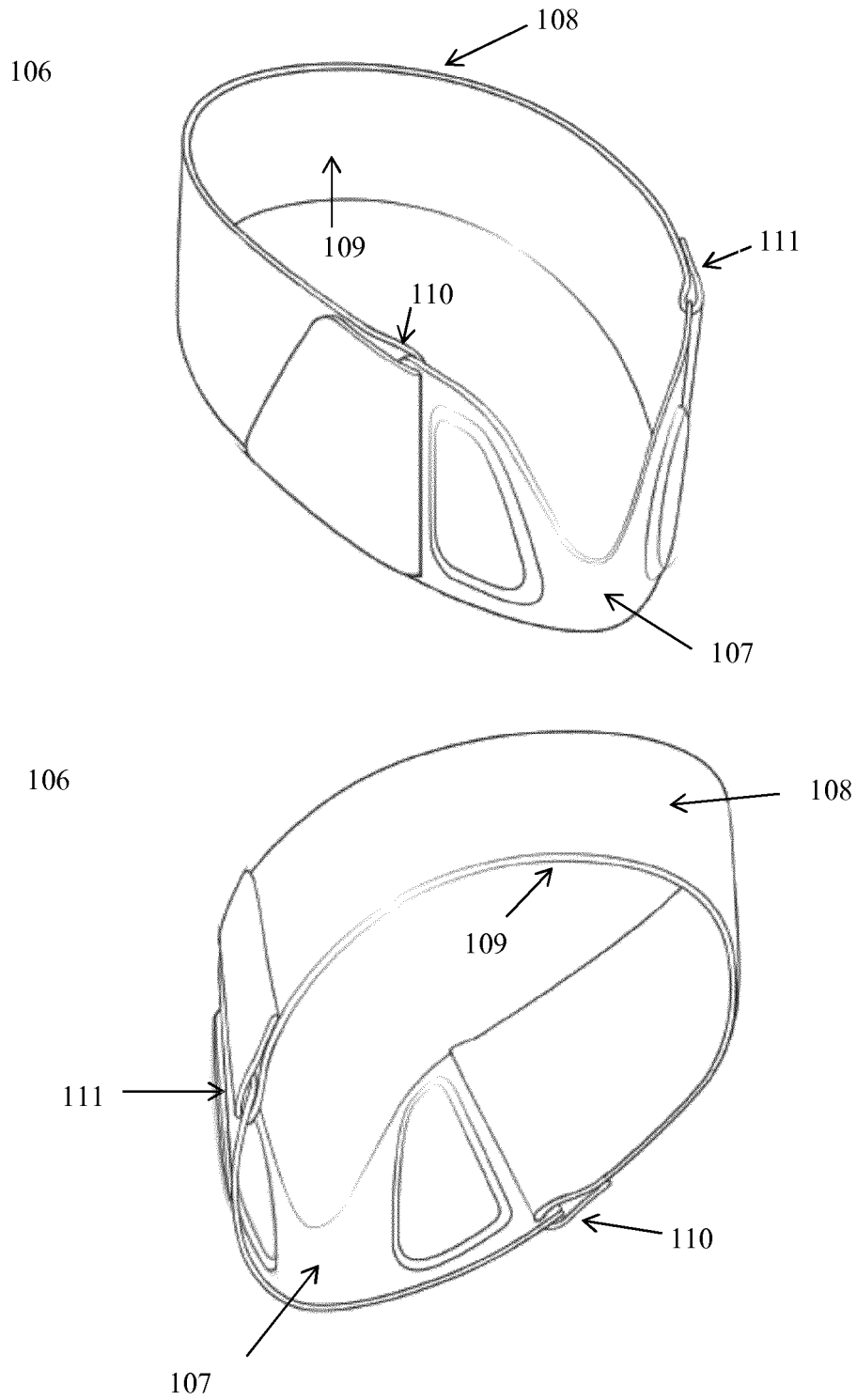

Figure 17

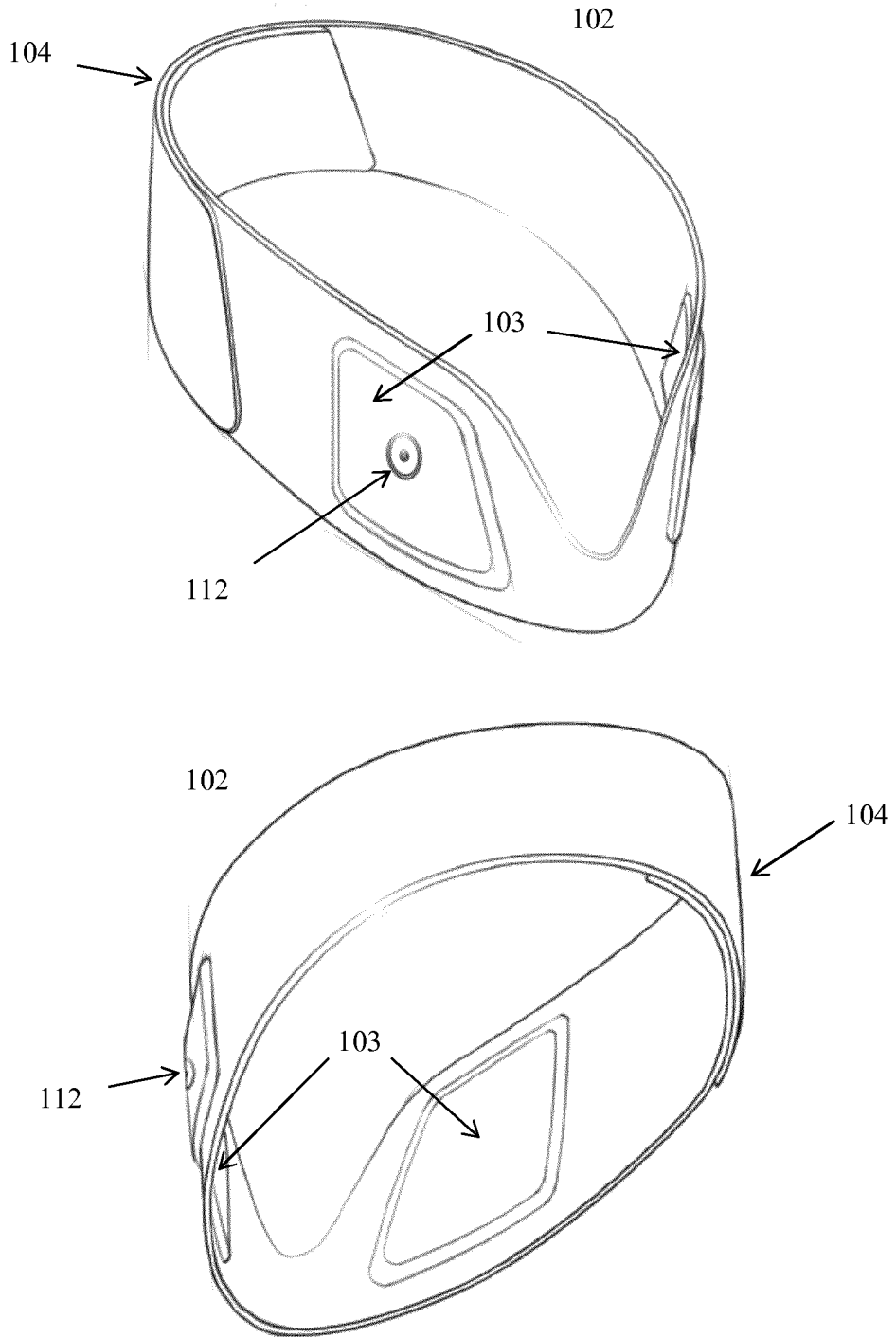

Figure 18

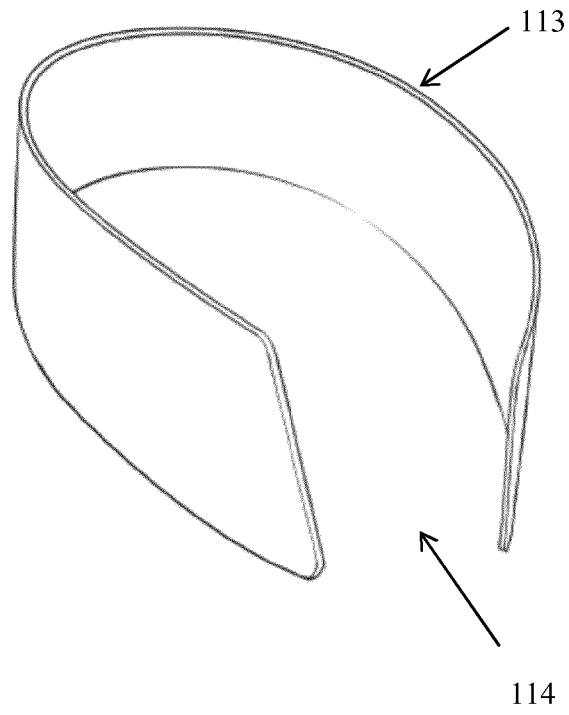

Figure 19

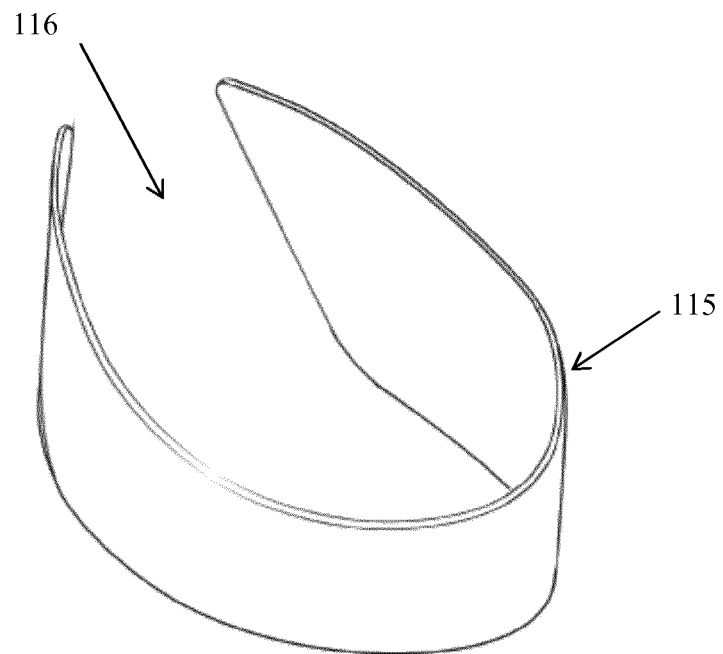

Figure 20

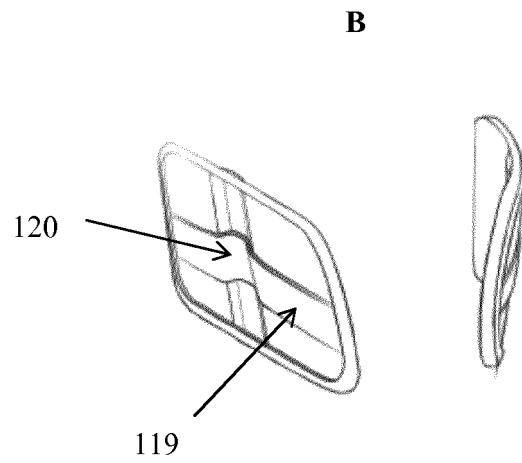
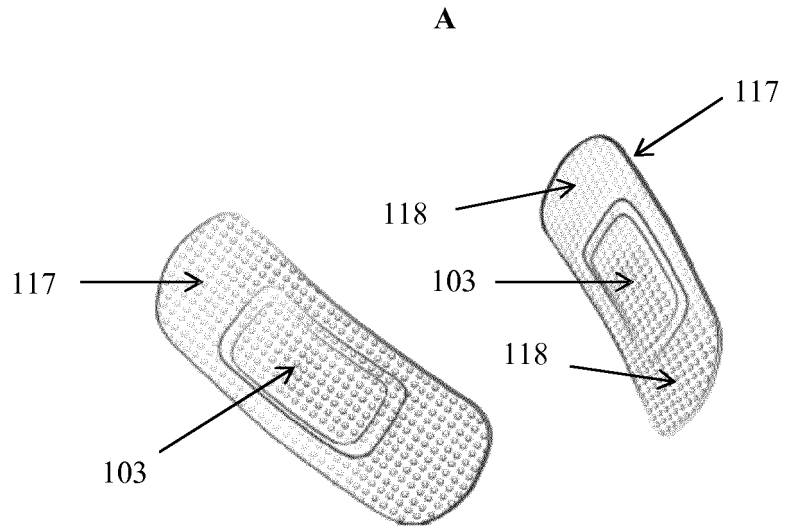

Figure 21

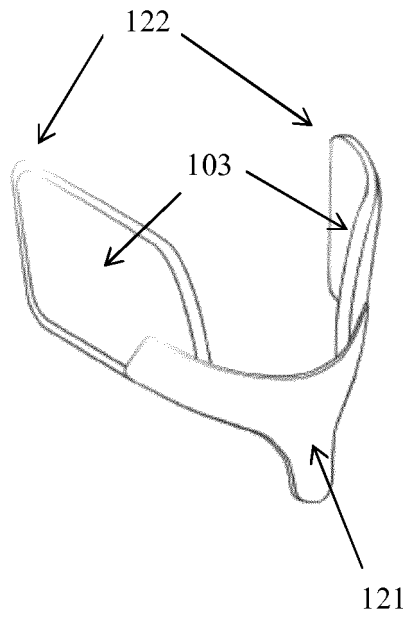

Figure 22

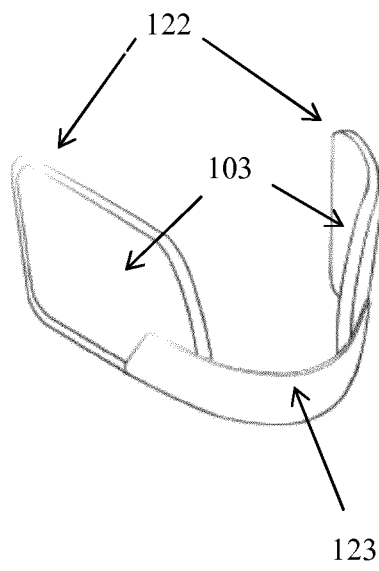

Figure 23

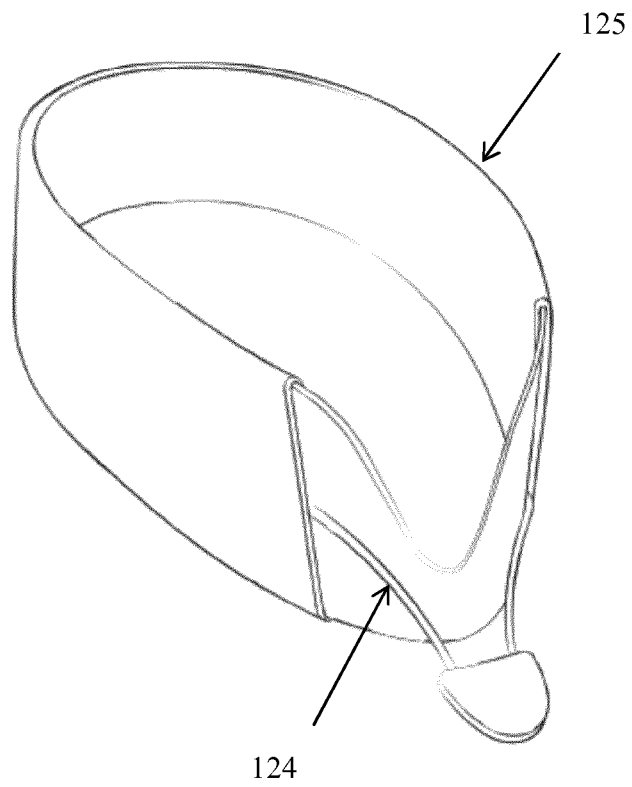

Figure 24

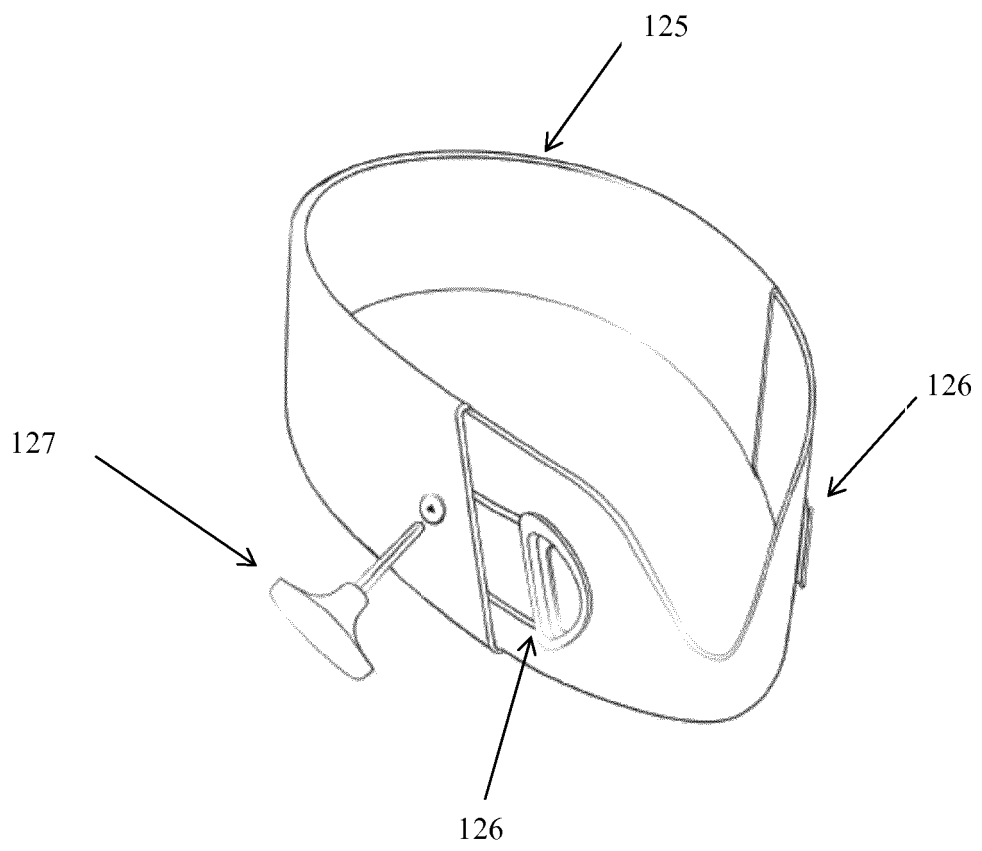

Figure 25

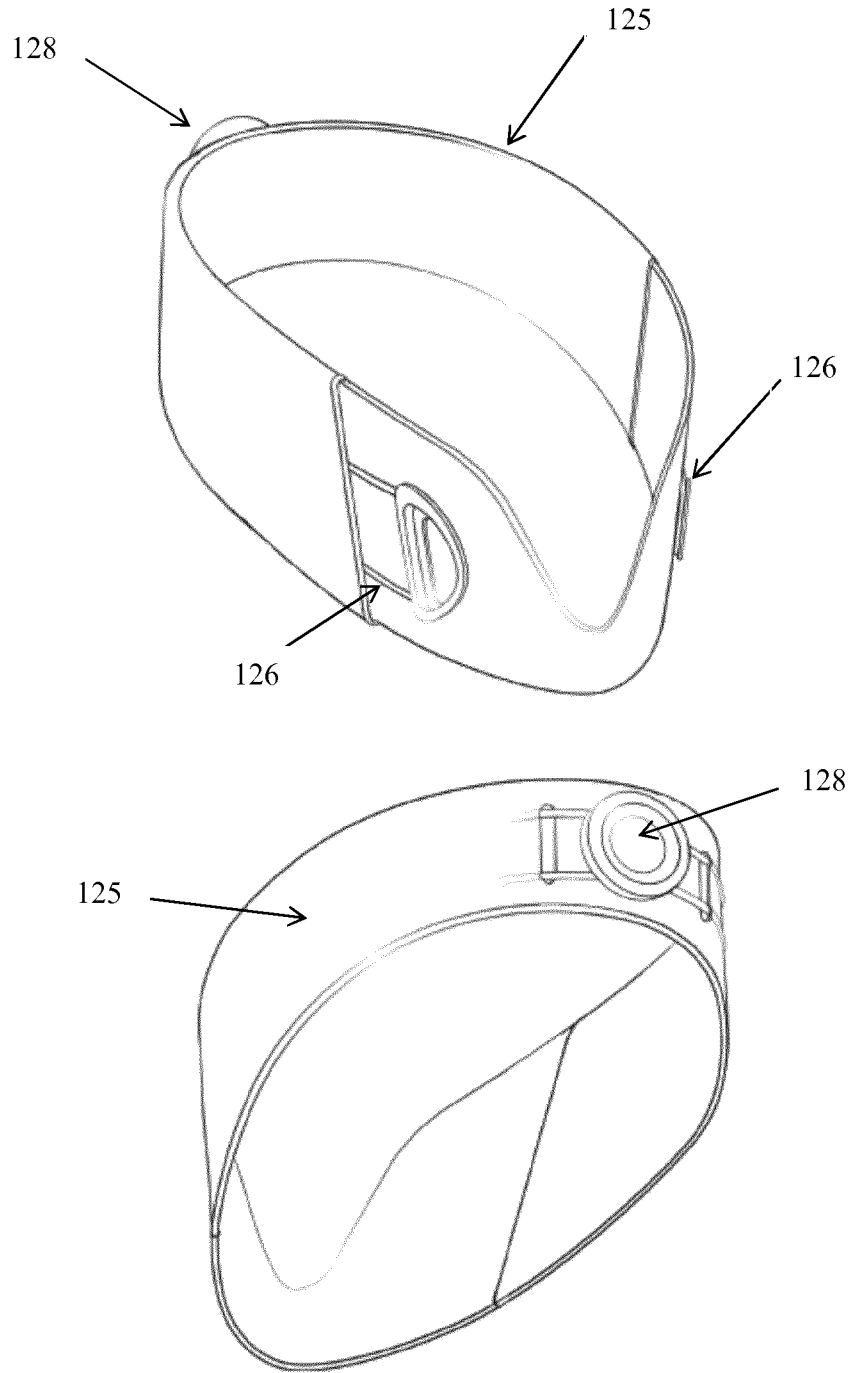

Figure 26

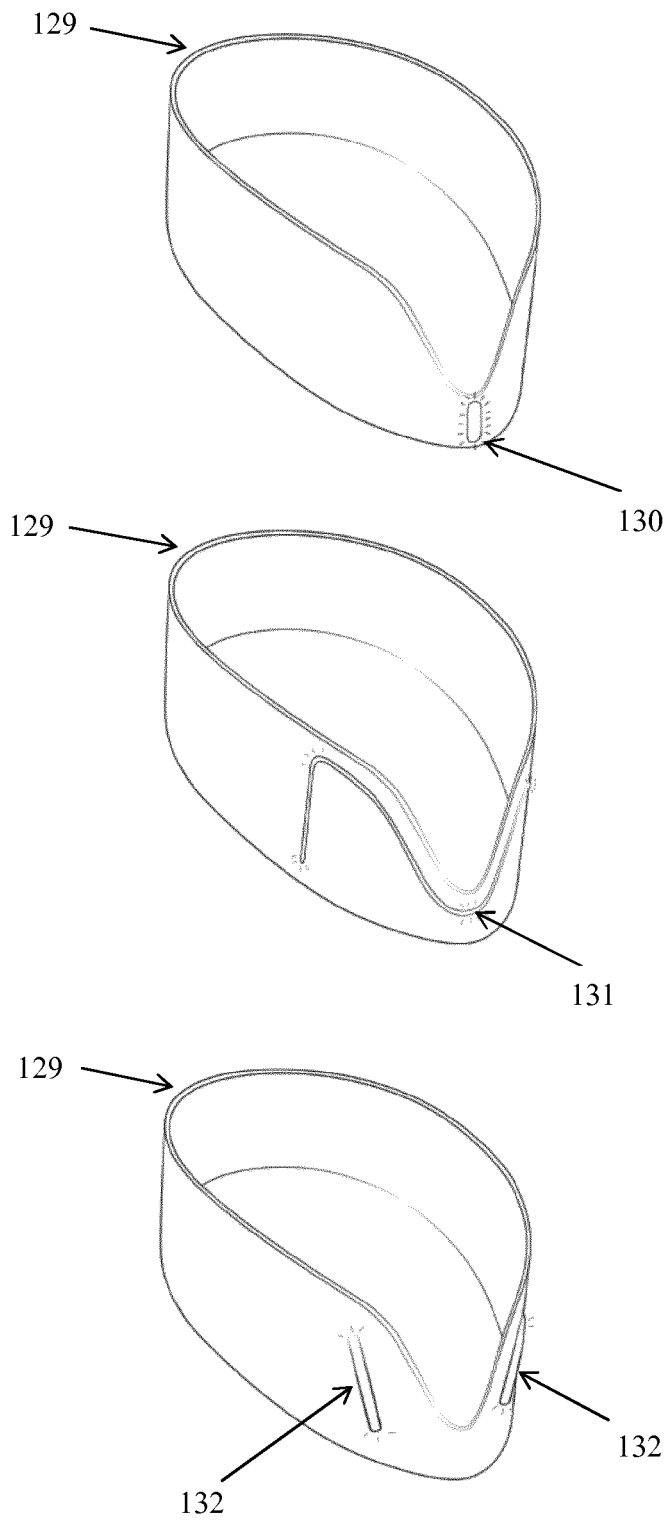

Figure 27

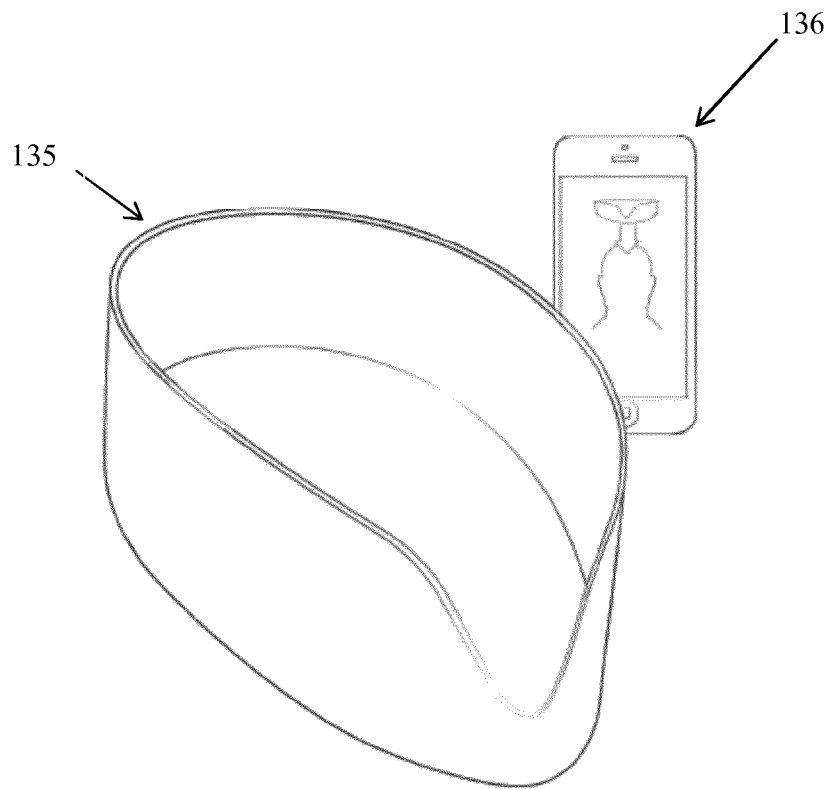
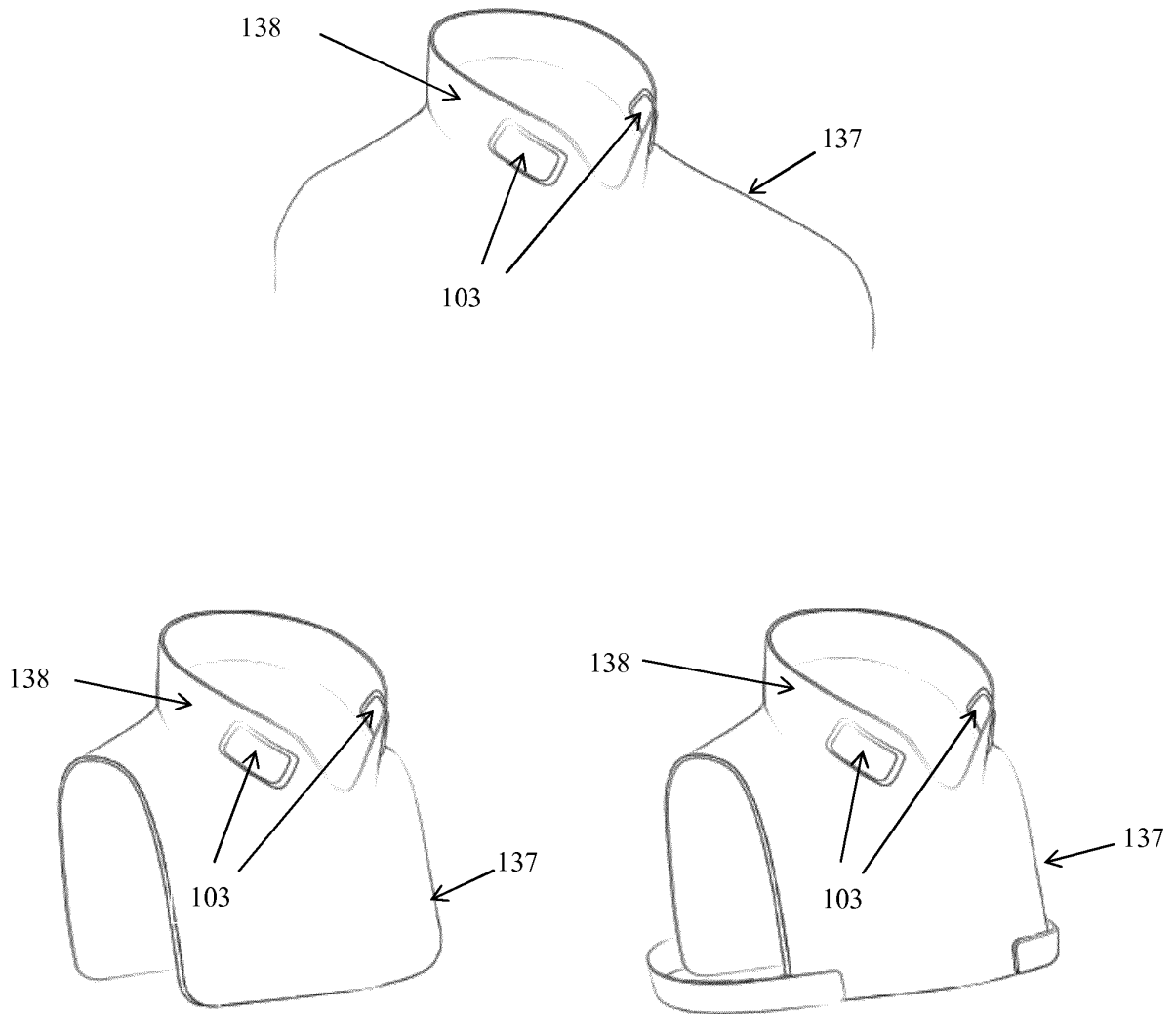

Figure 28



REFERENCES CITED IN THE DESCRIPTION

This list of references cited by the applicant is for the reader's convenience only. It does not form part of the European patent document. Even though great care has been taken in compiling the references, errors or omissions cannot be excluded and the EPO disclaims all liability in this regard.

Patent documents cited in the description

- WO 2012054262 A1 [0012]
- US 8381362 B [0083]
- US 20120246974 A [0083]

专利名称(译)	用于降低震荡或爆炸力造成伤害的可能性的装置		
公开(公告)号	EP2777411B1	公开(公告)日	2016-10-12
申请号	EP2013166318	申请日	2013-05-02
[标]申请(专利权)人(译)	TBI创新有限责任公司		
申请(专利权)人(译)	TBI的创新, LLC		
当前申请(专利权)人(译)	TBI的创新, LLC		
[标]发明人	SMITH DAVID VITITOE KEVIN JOHN FLOAT JAMISON JOSEPH LEEDER CHAD MICHAEL		
发明人	SMITH, DAVID VITITOE, KEVIN JOHN FLOAT, JAMISON JOSEPH LEEDER, CHAD MICHAEL		
IPC分类号	A41D13/05 A61B5/021 A63B71/12 A61B17/12 A61B5/00		
CPC分类号	A61B5/021 A61B5/6804 A61B5/6822 A61B17/1325 A61B17/135 A61B2017/00115 A61B2090/0807 A61B2560/0242 A63B71/1291 A61B17/132 A61H99/00		
优先权	13/841195 2013-03-15 US		
其他公开文献	EP2777411A1		
外部链接	Espacenet		

摘要(译)

一种用于向受试者的一个或多个颈静脉施加压力的装置，包括：圆周套环（10），其尺寸适于环绕受试者的颈部；一个或多个向内指向的突起（20,40）与轴环成一体；其中突起位于套环上，使得当套环环绕受试者的颈部时它们设置在受试者的一个或多个颈静脉上方，并且在所述一个或多个颈静脉上施加压力，相当于所述一个或多个颈静脉内的流体压力。范围为5mmHg至约50mmHg，并限制从受试者头部流出的血流。

