



(11) **EP 2 740 410 B1**

(12) **EUROPEAN PATENT SPECIFICATION**

(45) Date of publication and mention of the grant of the patent:
16.05.2018 Bulletin 2018/20

(51) Int Cl.:
A61B 8/08 (2006.01) A61B 5/00 (2006.01)

(21) Application number: **13191035.8**

(22) Date of filing: **31.10.2013**

(54) **Subject information acquisition device, method for controlling subject information acquisition device, and program therefor**

Vorrichtung zur Erfassung von Subjektinformationen, Verfahren zur Steuerung der Subjektinformationserfassungsvorrichtung, und Programm dafür

Dispositif d'acquisition d'informations de sujet, procédé de commande de dispositif d'acquisition d'informations de sujet et programme associé

(84) Designated Contracting States:
AL AT BE BG CH CY CZ DE DK EE ES FI FR GB GR HR HU IE IS IT LI LT LU LV MC MK MT NL NO PL PT RO RS SE SI SK SM TR

(30) Priority: **04.12.2012 JP 2012265322**

(43) Date of publication of application:
11.06.2014 Bulletin 2014/24

(73) Proprietor: **Canon Kabushiki Kaisha Tokyo 146-8501 (JP)**

(72) Inventor: **Nanaumi, Ryuichi Tokyo 146-8501 (JP)**

(74) Representative: **TBK Bavariaring 4-6 80336 München (DE)**

(56) References cited:
US-A- 5 640 959 US-A1- 2008 146 931
US-A1- 2011 125 022 US-A1- 2011 128 816
US-A1- 2011 251 475

- **SRIRANG MANOHAR ET AL: "Initial results of in vivo non-invasive cancer imaging in the human breast using near-infrared photoacoustics", OPTICS EXPRESS, OSA (OPTICAL SOCIETY OF AMERICA), WASHINGTON DC, (US), vol. 15, no. 19, 12 September 2007 (2007-09-12), pages 12277-12285, XP007918752, ISSN: 1094-4087**
- **LAMELA HORACIO ET AL: "Reconstruction algorithms for optoacoustic imaging based on fiber optic detectors", INDEPENDENT COMPONENT ANALYSES, WAVELETS, NEURAL NETWORKS, BIOSYSTEMS, AND NANOENGINEERING IX, SPIE, 1000 20TH ST. BELLINGHAM WA 98225-6705 USA, vol. 8058, no. 1, 13 May 2011 (2011-05-13) , pages 1-7, XP060017074, DOI: 10.1117/12.884316 [retrieved on 1901-01-01]**
- **MINGHUA XU ET AL: "Universal back-projection algorithm for photoacoustic computed tomography.", PHYSICAL REVIEW E, vol. 71, no. 1, 1 January 2005 (2005-01-01), pages 016706-016706, XP055040966, ISSN: 1539-3755**

Note: Within nine months of the publication of the mention of the grant of the European patent in the European Patent Bulletin, any person may give notice to the European Patent Office of opposition to that patent, in accordance with the Implementing Regulations. Notice of opposition shall not be deemed to have been filed until the opposition fee has been paid. (Art. 99(1) European Patent Convention).

EP 2 740 410 B1

Description

BACKGROUND OF THE INVENTION

5 Field of the Invention

[0001] The present invention relates to a subject information acquisition device for receiving elastic waves generated inside the subject, and acquiring subject information.

10 Description of the Related Art

[0002] As one of in vivo imaging techniques using near-infrared light, photo acoustic imaging (PAI) is known. General principles of photo acoustic imaging will be explained below in detail.

15 **[0003]** By irradiating a subject, such as a living body, with pulsed light generated from a light source, light which is propagated and diffused within the subject is absorbed with a light absorption body, and photo acoustic waves are generated. The principle of generation of the photo acoustic waves is known as the photo acoustic effect. In a living body, not all tissues absorb light in the same manner. A tumor's absorption of light energy in near-infrared light is higher than surrounding tissues. Therefore, a tumor that absorbs more light than surrounding tissues, instantly expands, and generates photo acoustic waves.

20 **[0004]** In photo acoustic imaging, the photo acoustic waves are received by a transducer, and by signalprocessing the received signal (image reconstruction), information such as spatial distribution of the initial sound pressure of photo acoustic waves that occur upon absorption of light energy in the subject is turned into images. The spatial distribution of sound pressure generated is related to an absorption coefficient of light. Therefore, diagnosing a subject using a spatial distribution related to the absorption coefficient of light is being studied.

25 **[0005]** As an example of photo acoustic imaging, Non-Patent Literature 1 (Minghua Xu and Lihong V. Wang, "Universal back-projection algorithm for photoacoustic computed tomography", PHYSICAL REVIEW E 71,016706 (2005)) discloses a photo acoustic imaging technique which calculates initial sound pressure of photo acoustic waves by image reconstruction by time-domain back projection.

30 **[0006]** Hereinafter, the image reconstruction method disclosed in Non-Patent literature 1 will be explained with reference to Fig. 8. Fig. 8 illustrates a block diagram in which an array transducer 1300 receives photo acoustic waves generated in an interest region 1110 within a subject 1100. The array transducer 1300 includes n transducers 1301 to 130n arranged one-dimensionally.

35 **[0007]** Non-Patent Literature 1 discloses to acquire the initial sound pressure p_0 in the interest region 1110 by the time-domain back projection represented by formula (1).

$$p_0(r) = \sum_{i=1}^n \Delta\Omega_i \times b\left(d_i, \frac{|d_i - r|}{v}\right) / \sum_{i=1}^n \Delta\Omega_i \quad \text{Formula (1)}$$

40 **[0008]** In formula (1), d_i represents a position vector of a transducer 130i, r represents a position vector of the interest region 1110, v represents the sound velocity within the subject 1100, and b represents a reception signal that has been subjected to a process including differentiation processing. A sum symbol \sum represents the sum of the transducers 1301 to 130n. Furthermore, $(|d_i - r|/v)$ indicates a time t at which the photo acoustic waves generated in the interest region 1110 arrive at the transducer 130i.

45 **[0009]** Furthermore, the reception signal b which has been subjected to differentiation processing or the like is represented by formula (2).

$$b(d_i, t) = 2 \cdot p_d(d_i, t) - 2 \cdot t \cdot \partial p_d(d_i, t) / \partial t \quad \text{Formula (2)}$$

[0010] In formula (2), $p(d_i, t)$ represents a value at the time t of the reception signal output by the transducer located at the position d_i .

55 **[0011]** Furthermore, $\Delta\Omega_i$ formula (1) represents a weighting factor represented by formula (3).

$$\Delta\Omega_i = \frac{\Delta S_i}{|r - d_i|^2} \cdot \left[n_{0i}^s \cdot \frac{r - d_i}{|r - d_i|} \right] = \frac{\Delta S_i}{|r - d_i|^2} \cdot \cos \theta_i \quad \text{Formula (3)}$$

5

[0012] In formula (3), n_{0i}^s represents a unit normal vector of a reception surface of the transducer 130i, θ_i represents an angle formed by a vector $r - d_i$ and the vector n_{0i}^s and ΔS_i represents the area of a reception surface of the i-th transducer. That is, the weighting factor $\Delta\Omega_i$ is equal to the solid angle of a cone whose vertex is the interest region 1110 and whose bottom surface is the reception surface of the transducer 130i.

10 **[0013]** As described above, Non-Patent Literature 1 discloses to obtain initial sound pressure by correcting a reception signal using a weighting factor based on the solid angle formed by an interest region and a transducer.

[0014] Furthermore, Patent Literature 1 (Japanese Patent Laid-Open No. 2010-104816) discloses photo acoustic imaging that receives photo acoustic waves in a wide region of a subject by mechanically moving a transducer. However, in the case where the calculation of initial sound pressure is performed by using many reception signals obtained in the wide region of the subject, the amount of data to be handled increases, therefore it takes a long time to calculate the initial sound pressure.

15 **[0015]** Thus, Patent Literature 1 discloses a method to sequentially obtain initial sound pressures, using signals received up to the point of calculation during the scanning. Furthermore, Patent Literature 1 discloses to add a plurality of initial sound pressures obtained sequentially.

20 **[0016]** The US-2011/0251475 A1 discloses a biological information acquisition apparatus which focuses on a correction for refraction in image reconstruction.

[0017] Srirang Manohar et al.: "Initial results of in vivo non-invasive cancer imaging in the human breast using near-infrared photoacoustics", OPTICS EXPRESS, OSA (OPTICAL SOCIETY OF AMERICA), Washington DC (US), vol. 15, no. 19, 12 September 2007, pages 12277-12285, XP007918752, ISBN: 1094-4087, and Lamela Horacio et al.: "Reconstruction algorithm for optoacoustic imaging based on fiber optic detectors", INDEPENDENT COMPONENT ANALYSES, WAVELETS, NEURAL NETWORKS, BIOSYSTEMS, AND NANOENGINEERING IX, SPIE, 1000 20th ST. BELLINGHAM WA 98225-6705 USA, vol. 8058, no. 1, 13 May 2011, pages 1-7, XP060017074, DOI: 10.1117/12.884316, are concerned with image reconstruction and analysis.

25 **[0018]** The US 2011/0128816 discloses a received data processing apparatus of photoacoustic tomography.

30

SUMMARY OF THE INVENTION

[0019] Accordingly, the present invention provides a subject information acquisition device that can reduce the time to obtain subject information such as initial sound pressure, and furthermore, that can suppress a decrease in the quantitativity of the subject information.

35 **[0020]** The present invention in its first aspect provides a subject information acquisition device as specified in claims 1 to 12.

[0021] The present invention in its second aspect provides a method for controlling a subject information acquisition device as specified in claim 13.

40 **[0022]** The present invention in its third aspect provides a program as specified in claim 14.

[0023] Further features of the present invention will become apparent from the following description of exemplary embodiments with reference to the attached drawings.

BRIEF DESCRIPTION OF THE DRAWINGS

45

[0024]

Fig. 1 is a diagram illustrating a subject information acquisition device according to an embodiment.

Fig. 2 is a block diagram of the subject information acquisition device illustrating a state in which an array transducer is moved to different positions.

50 Fig. 3 is a flowchart of a subject information acquisition process according to an embodiment.

Fig. 4A is a diagram illustrating a state in which photo acoustic waves are received when an array transducer is positioned at a first position.

Fig. 4B is a diagram illustrating a state in which photo acoustic waves are received when an array transducer is positioned at a second position.

55 Fig. 5 illustrates initial sound pressure distribution obtained with a subject information acquisition device, in accordance in an exemplary embodiment of the present invention.

Fig. 6 illustrates initial sound pressure distribution obtained in a comparative example.

Fig. 7 is a diagram illustrating an irradiation optical system according to an embodiment.

Fig. 8 is a diagram illustrating a subject information acquisition device according to related art.

DESCRIPTION OF THE EMBODIMENTS

5

(Device Configuration)

[0025] Firstly, with reference to Fig. 1, the device configuration of a subject information acquisition device according to an embodiment of the present invention will be explained. Fig. 1 is a diagram illustrating a subject information acquisition device according to a first embodiment.

10

[0026] The subject information acquisition device according to this embodiment includes a light source 200, an irradiation optical system 210, an array transducer 300 as an elastic wave receiving unit (elastic wave detector), a scanning mechanism 400 as a moving part, a signal processing apparatus 500 as a signal processing unit, and a display unit 600. The array transducer 300 according to this embodiment has one transducer arranged in a direction x and eight transducers arranged in a direction y .

15

[0027] The irradiation optical system 210 leads light generated by the light source 200 and irradiates a subject 100 with the light. A light absorption body within the subject 100 absorbs light energy and generates photo acoustic waves as elastic waves. The generated photo acoustic waves propagate within the subject 100 and reach the array transducer 300. The array transducer 300 receives the photo acoustic waves and outputs a reception signal to the signal processing apparatus 500. The signal processing apparatus 500 performs image reconstruction based on the reception signal, and through this obtains initial sound pressure distribution as subject information. Furthermore, the signal processing apparatus 500 generates image data from the initial sound pressure distribution, and then the image data is displayed on the display unit 600.

20

[0028] Furthermore, according to this embodiment, by changing measurement parameters during measurement, initial sound pressure distribution as subject information is obtained from a plurality of reception signals corresponding to a plurality of measurement states obtained by receiving photo acoustic waves in the plurality of different measurement states. The measurement state when the subject is irradiated with light will herein be defined as the measurement state.

25

[0029] Here, a measurement parameter used in an aspect of the present invention, represents a parameter of a measurement state which influences a weighting factor which corrects a reception signal. For example, a measurement parameter is the position of a transducer relative to an interest region, the angle formed by a reception surface of the transducer and the interest region, a transducer used to obtain subject information in the interest region, or the like. The transducer to be used corresponds to the reception signal to be used for signal processing, which will be explained more in detail later. That is, selecting a transducer to be used is equivalent to selecting a reception signal output from the transducer. Moreover, a plurality of measurement parameters may be combined together, and be considered as a measurement parameter in a measurement state.

30

35

[0030] Fig. 2 is a diagram illustrating a state in which the array transducer 300 is moved by the scanning mechanism 400 in at least two directions different from each other. The scanning mechanism 400 includes a main-scanning mechanism 410 and a sub-scanning mechanism 420. The main-scanning mechanism 410 moves the array transducer 300 along a main-scanning direction (direction x), and the sub-scanning mechanism 420 moves the array transducer 300 along a sub-scanning direction (direction y).

40

[0031] The main-scanning mechanism 410 moves the array transducer 300 to form a plurality of main-scanning areas. The sub-scanning mechanism 420 moves the array transducer 300 to form an overlap area 330, which is an area where an i -th main-scanning area 310 and an $i+1$ -th main-scanning area 320 partially overlap.

[0032] According to this embodiment, the signal processing apparatus 500 is configured so that a user can set the overlap width of sub-scanning in a desired manner. Furthermore, the signal processing apparatus 500 is also configured so that the user can set main-scanning areas in a desired manner. Thus, the signal processing apparatus 500 controls the scanning mechanism 400 with a scanning pattern corresponding to the overlap width and the scanning areas set as described above.

45

[0033] Furthermore, the signal processing apparatus 500 may control the scanning mechanism 400 by referring to lookup tables which correspond to a plurality of specific scanning patterns stored in a non-illustrated memory of the signal processing apparatus 500.

50

(Subject Information Acquisition Method)

[0034] A subject information acquisition process (method) according to an embodiment will now be explained with reference to a flowchart illustrated in Fig. 3. The signal processing apparatus 500 reads a program which is stored in the memory of the signal processing apparatus 500 and in which computer-executable instructions for a subject information acquisition method is described. Based on the instructions, the signal processing apparatus 500 causes a subject

55

information acquisition device to execute the read subject information acquisition method.

(S110: Step of receiving elastic waves in a first measurement state and acquiring a first reception signal)

5 **[0035]** In step S110, the scanning mechanism 400 first moves the array transducer 300 at a first position 311. When the array transducer 300 is positioned at the first position 311, the irradiation optical system 210 leads light generated by the light source 200 and irradiates the subject 100 with irradiation light 211. The transducers 302 to 306 of the array transducer 300 are selectively used, and detect photo acoustic waves as first elastic waves to output a first reception signal P_d^1 . The first reception signal output P_d^1 from the array transducer 300 is stored into the memory of the signal processing apparatus 500. In Fig. 2, the first position 311 is a specific position in the i -th main-scanning area 310 illustrated in Fig. 2. A value of the first reception signal output P_d^1 relating to the first position 311 is represented by a superscript "1". A value relating to a second position, which will be described later, is represented by a superscript "2", and so on.

10 **[0036]** In this embodiment, the measurement state in which the array transducer 300 can receive photo acoustic waves at the first position 311 and the measurement state in which the transducers 302 to 306 are used are defined as the first measurement state.

15 **[0037]** At this time, the signal processing apparatus 500 controls the light source 200 and the scanning mechanism 400 in synchronization with each other so that the light source 200 irradiates the subject 100 with light, and photo acoustic waves are received when the array transducer 300 is located at the first position 311.

20 **[0038]** Fig. 4A illustrates the state in which the array transducer 300 located at the first position 311 receives photo acoustic waves generated in an interest region 110. Here, the interest region 110 is set to a specific position in the overlap area 330 illustrated in Fig. 2. In Fig. 4A, d_3^1 represents a position vector of the transducer 303 when the array transducer 300 is located at the first position 311.

25 **[0039]** In step S110, the transducers 302 to 306 located at the first position 311 are used. Here, a transducer to be used is determined, taking into consideration the directivity angle of the transducer. For example, in step S110, a directivity angle 121 of the transducer 301 and a directivity angle 122 of the transducers 307 to 308 do not include the interest region 110. Thus, in step S110, the transducers 301, 307, and 308 are not used, whereas, the transducers 302 to 306 are used. Here, not using a transducer includes not storing a reception signal output from the transducer into the memory or not using the reception signal stored in the memory for signal processing described later.

30 **[0040]** A transducer to be used may be determined, taking into consideration attenuation of photo acoustic waves, as well as directivity angle. That is, a transducer to be used may be determined on the basis of the distance between an interest region and the transducer.

[0041] Furthermore, as described in Patent Literature 1, the sum of a plurality of reception signals acquired a plurality of times at the same position may be used as a reception signal at the position.

35 **[0042]** Furthermore, after performing a process, such as multiplication processing, division processing, filtering processing, differentiation processing, envelope detection processing, logarithmic compression processing, or orthogonal detection processing, on a reception signal, the signal processing apparatus 500 may store the processed reception signal into the memory. Alternatively, after storing a reception signal into the memory, the signal processing mentioned above may be performed on the reception signal stored in the memory. A reception signal used in an aspect of the present invention includes a reception signal that has been subjected to the above-mentioned signal processing.

40 **[0043]** In the case where a photo acoustic imaging device is employed as a subject information acquisition device, it is preferable that a process including differentiation processing is performed on a reception signal, as represented by formula (2).

(S120: Step of correcting the first reception signal by a first weighting factor)

45 **[0044]** In step S120, the signal processing apparatus 500 corrects the first reception signal corresponding to the first measurement state acquired in step S110 by a first weighting factor. The first reception signal corrected by the first weighting factor is stored into the memory of the signal processing apparatus 500.

50 **[0045]** The first reception signal corresponding to the interest region 110 is a reception signal acquired at a time when photo acoustic waves generated in the interest region 110 are received by a transducer at the first position 311, among reception signals acquired in time series. That is, in this embodiment, the reception signal corresponding to the interest region 110 is a reception signal obtained at the time t , which is a value obtained by dividing the distance (d_r) between a transducer and the interest region 110 by sonic speed v , where the time t_0 at which irradiation with light is performed is set to 0.

55 **[0046]** Furthermore, a value determined based on a measurement parameter in a measurement state and the position of an interest region is used as a weighting factor. In this embodiment, as disclosed in Non-Patent Literature 1, the solid angle $\Delta\Omega$ of a cone whose vertex is defined by the interest region 110 and whose bottom surface is defined by the reception surface of the array transducer 300 is used as a weighting factor.

[0047] In step S120, the signal processing apparatus 500 calculates a first weighting factor $\Delta\Omega^1$ corresponding to the transducers 302 to 306 using formula (3), on the basis of the position of the first position 311 and the position of the interest region 110. The signal processing apparatus 500 corrects the first reception signal corresponding to the interest region 110 by the first weighting factor. Formula (4) represents a corrected first reception signal $P_c^1(r)$ corresponding to the interest region 110.

$$P_c^1(r) = \sum_{i=2}^6 \Delta\Omega_i^1 \times P_{di}^1 \left(d_i^1, \frac{|d_i^1|}{v} \right) \quad \text{Formula (4)}$$

[0048] In step S120, the signal processing apparatus 500 calculates the corrected first reception signal represented by formula (4) by multiplying first reception signals acquired by individual transducers corresponding to the interest region 110 by the first weighting factor.

[0049] In the case where a scanning pattern is set on the basis of a lookup table, the signal processing apparatus 500 may acquire a weighting factor on the basis of a specific scanning pattern corresponding to a selected lookup table. Alternatively, the signal processing apparatus 500 may acquire a weighting factor by referring to a lookup table in which a weighting factor corresponding to a set scanning pattern is stored.

[0050] Furthermore, in the case where the array transducer 300 receives photo acoustic waves as in this embodiment, a plurality of reception signals acquired by transducers of the array transducer 300 located at the first position 311 may be collectively called a "first reception signal".

[0051] Furthermore, a plurality of reception signals acquired at different positions by one or more transducers may also be collectively called a "first reception signal". In this case, a plurality of positions at which photo acoustic waves are received are collectively called a "first position".

[0052] For example, the case where all the reception signals acquired by the array transducer 300 by the i-th main-scanning are collectively called a "first reception signal" will be considered. In this case, the scanning areas 310 scanned by the i-th main-scanning are collectively called a "first position".

(S210: Step of receiving elastic waves in a second measurement state and acquiring a second reception signal)

[0053] In step S210, the scanning mechanism 400 first scans the array transducer 300 at a second position 321. When the array transducer 300 is located at the second position 321, the irradiation optical system 210 leads light generated by the light source 200 and irradiates the subject 100 with the irradiation light 211. The transducers 301 to 304 of the array transducer 300 are selectively used, and detect photo acoustic waves as second elastic waves to output a second reception signal P_d^2 . The second signal output from the array transducer 300 is stored into the memory of the signal processing apparatus 500.

[0054] The second position 321 represents a specific position in the i+1-th main-scanning area 320 illustrated in Fig. 2.

[0055] At this time, the signal processing apparatus 500 controls the light source 200 and the scanning mechanism 400 in synchronization with each other so that the light source 200 irradiates the subject 100 with light and photo acoustic waves are received when the array transducer 300 is located at the second position 321.

[0056] Fig. 4B illustrates the state in which the array transducer 300 located at the second position 321 receives photo acoustic waves generated in the interest region 110. In Fig. 4B, d_3^2 represents a position vector of the transducer 303 when the array transducer 300 is located at the second position 321.

[0057] Similar to step S110, the signal processing apparatus 500 determines a transducer to be used, on the basis of the directivity angle of the transducer, in step S210. In step S210, since a directivity angle 123 of the transducers 305 to 308 does not include the interest region 110, only the transducers 301 to 304 are used.

(S220: Step of correcting the second reception signal by a second weighting factor)

[0058] In step S220, the signal processing apparatus 500 corrects the second reception signal corresponding to the interest region 110 acquired in step S210 by a second weighting factor. The second reception signal corrected by the second weighting factor is stored into the memory of the signal processing apparatus 500.

[0059] In this embodiment, the signal processing apparatus 500 acquires a second weighting factor $\Delta\Omega^2$ corresponding to the transducers 301 to 304 using formula (3) on the basis of the second position 321 of the array transducer 300 and the position of the interest region 110. Then, the signal processing apparatus 500 calculates a corrected second reception signal by multiplying the second reception signal corresponding to the interest region 110 acquired in step S210 by the second weighting factor.

[0060] Then, the signal processing apparatus 500 multiplies the second reception signal in the interest region 110 by

the second weighting factor to calculate a corrected second reception signal in the interest region 110. Formula (5) represents the corrected second reception signal $P_C^2(r)$ in the interest region 110.

$$P_C^2(r) = \sum_{i=1}^4 \Delta\Omega_i^2 \times P_{di}^2 \left(d_i^2, \frac{|d_i^2 - r|}{v} \right) \quad \text{Formula (5)}$$

[0061] The signal processing apparatus 500 may correct the first reception signal and the second reception signal by weighting factors and acquire the sum of the corrected reception signals as a corrected second reception signal in the interest region 110, as represented by formula (6).

$$P_C^2(r) = \sum_{i=2}^6 \Delta\Omega_i^1 \times P_{di}^1 \left(d_i^1, \frac{|d_i^1 - r|}{v} \right) + \sum_{i=1}^4 \Delta\Omega_i^2 \times P_{di}^2 \left(d_i^2, \frac{|d_i^2 - r|}{v} \right) \quad \text{Formula (6)}$$

[0062] Preferably, step S120 is performed prior to step S220. As described above, by performing step S220 after completing step S120 by the signal processing apparatus 500, the time at which both steps S120 and S220 are completed can be made earlier than the case where steps S120 and S220 are performed at the same time. That is, the time required to acquire subject information can be shortened.

(S300: Step of acquiring subject information in the interest region on the basis of the sum of the corrected first reception signal and the corrected second reception signal and the sum of the first weighting factor and the second weighting factor)

[0063] In step S300, the signal processing apparatus 500 acquires initial sound pressure as subject information in the interest region, on the basis of the sum of the corrected first reception signal acquired in step S120 and the corrected second reception signal acquired in step S220 and the sum of the first weighting factor and the second weighting factor.

[0064] In step S300, the signal processing apparatus 500 calculates initial sound pressure P_0 in an interest region by dividing the sum of the corrected first reception signal and the corrected second reception signal by the sum of the first weighting factor and the second weighting factor, as represented by formula (7).

$$P_0(r) = \frac{\sum_{i=2}^6 \Delta\Omega_i^1 \times P_{di}^1 \left(d_i^1, \frac{|d_i^1 - r|}{v} \right) + \sum_{i=1}^4 \Delta\Omega_i^2 \times P_{di}^2 \left(d_i^2, \frac{|d_i^2 - r|}{v} \right)}{\sum_{i=2}^6 \Delta\Omega_i^1 + \sum_{i=1}^4 \Delta\Omega_i^2} \quad \text{Formula (7)}$$

[0065] The numerator of formula (7) is the sum of the corrected first reception signal represented by formula (4) and the corrected second reception signal represented by formula (5). The denominator of formula (7) is the sum of the first weighting factor and the second weighting factor.

[0066] As described above, by dividing the corrected first reception signal and the corrected second reception signal by the same value (the sum of the first weighting factor and the second weighting factor), the quantity of the initial sound pressure obtained at each point increases.

[0067] For example, in the case where the reciprocal of initial sound pressure is obtained as subject information, the signal processing apparatus 500 may divide the sum of the first weighting factor and the second weighting factor by the sum of the corrected first reception signal and the corrected second reception signal.

[0068] That is, either in the case where initial sound pressure is obtained or in the case where the reciprocal of initial sound pressure is obtained, the signal processing apparatus 500 may acquire the ratio of the sum of the first weighting factor and the second weighting factor to the sum of the corrected first reception signal and the corrected second reception signal.

[0069] Furthermore, the signal processing apparatus 500 may acquire the light amount distribution within a subject in

each measurement state. Furthermore, for example, by dividing the initial sound pressure in an interest region acquired in step S300 by the light amount value in the interest region, the signal processing apparatus 500 can acquire an absorption coefficient in the interest region. At this time, the signal processing apparatus 500 may use the average of a plurality of light amount values corresponding to measurement states for acquisition of the absorption coefficient. Furthermore, the signal processing apparatus 500 is capable of acquiring substance concentration distribution, such as the degree of oxygen saturation, on the basis of absorption coefficients in the interest region acquired by light of a plurality of wavelengths.

[0070] The present invention may also be applied to an aspect in which subject information is acquired from corrected reception signals acquired at three or more positions.

[0071] Furthermore, although a photo acoustic imaging device that acquires subject information by receiving photo acoustic waves has been explained in this embodiment, the present invention can also be applied to an ultrasound diagnosis device that acquires subject information by transmitting and receiving ultrasonic waves. The present invention can be applied to various devices that receive elastic waves and correct a reception signal using a weighting factor to acquire subject information. That is, elastic waves used in an aspect of the present invention include photo acoustic waves generated by a photo acoustic effect and reflected waves of transmitted ultrasonic waves.

[0072] For example, in an ultrasound diagnosis device according to an aspect of the present invention, an array transducer functioning as an ultrasonic wave transmitter first transmits ultrasonic waves to a subject, and the array transducer functioning as an ultrasonic wave receiver receives ultrasonic waves reflected inside the subject and outputs a reception signal. At this time, the array transducer transmits and receives ultrasonic waves while changing a measurement parameter in each of a plurality of measurement states. A measurement parameter used in an ultrasound diagnosis device may be the position of an ultrasonic wave receiver, the number of transducers used, the direction in which ultrasonic waves are transmitted, or the like. Here, a transducer used represents a transducer corresponding to a reception signal to be used later in signal processing. Furthermore, in an ultrasound diagnosis device, it is preferable that an array transducer performs transmission focusing and reception focusing and outputs a reception signal. Alternatively, the array transducer may transmit plane ultrasonic waves and receive reflected waves of the plane ultrasonic waves.

[0073] Then, a signal processing device corrects reception signals in measurement states using weighting factors based on measurement parameters in the measurement states and the position of an interest region. Then, the signal processing device acquires structural information of the subject as subject information, on the basis of the sum of corrected reception signals and the sum of weighting factors.

[0074] Structural information is information based on the photo acoustic impedance distribution within a subject. For example, structural information may be a B-mode image, a Doppler image, or an elastographic image that can be obtained by known ultrasound diagnosis devices.

[0075] The subject information acquisition method described above may be configured as a program that causes the signal processing apparatus 500 as a computer to execute to the subject information acquisition method.

(Effects of Embodiment)

[0076] Fig. 5 illustrates initial sound pressure distribution within a subject acquired by the subject information acquisition method according to this embodiment.

[0077] In this embodiment, by performing main-scanning in the direction x and sub-scanning in the direction y on the array transducer, a reception signal is acquired. The array transducer is moved in a sub-scanning direction (sub-scanned) in such a manner that main-scanning areas overlap in regions represented by arrows.

[0078] A corrected reception signal in a region in a direction z of a scanning area (region facing in front of the array transducer) is acquired for each main-scanning operation.

[0079] In the region in the direction z of overlapping scanning areas, initial sound pressure is acquired by dividing the sum of the corrected reception signals by the sum of weighting factors corresponding to the overlapping scanning areas, as in formula (7). In contrast, in the other regions, initial sound pressure is acquired as in formulae (4) and (5).

[0080] As described above, in the region in the direction z of the overlapping scanning areas, since the initial sound pressure is acquired by the subject information acquisition method according to this embodiment, a high quantitativity is achieved. As a result, the continuity of the initial sound pressure distribution in this embodiment illustrated in Fig. 5 is higher than the continuity of the initial sound pressure distribution in a comparative example illustrated in Fig. 6, which will be described later.

(Comparative Example)

[0081] In contrast, the case where initial sound pressures are sequentially acquired as disclosed in Patent Literature 1 using the method for acquiring initial sound pressure disclosed in Non-Patent Literature 1 and the average of the initial

sound pressures is obtained, will be considered as a comparative example.

[0082] For example, the case in which a signal processing apparatus acquires an initial sound pressure $P_0(r)$ in an interest region by obtaining the average of an initial sound pressure P_0^1 based on a reception signal acquired at the first position 311 and an initial sound pressure P_0^2 based on a reception signal acquired at the second position 321 will be considered.

[0083] At this time, the initial sound pressure acquired in the comparative example is represented by formula (8), with reference to formula (1). It is assumed that also in the comparative example, a reception signal is acquired in a manner similar to this embodiment.

$$\begin{aligned}
 p_0(r) &= \frac{P_0^1(r) + P_0^2(r)}{2} \\
 &= \frac{\sum_{i=2}^6 \Delta\Omega_i^1 \times P_{di}^1 \left(d_i^1, \frac{|d_i^1 - r|}{v} \right) + \sum_{i=1}^4 \Delta\Omega_i^2 \times P_{di}^2 \left(d_i^2, \frac{|d_i^2 - r|}{v} \right)}{\sum_{i=2}^6 \Delta\Omega_i^1 + \sum_{i=1}^4 \Delta\Omega_i^2}
 \end{aligned}
 \tag{8}$$

[0084] As represented by formula (8), initial sound pressures represented as terms of the numerator are acquired by dividing corrected reception signals by different weighting factors. Thus, the quantity of the initial sound pressure obtained by averaging initial sound pressures acquired using different weighting factors may be decreased.

[0085] Fig. 6 illustrates the initial sound pressure distribution of a subject in the comparative example. The array transducer is sub-scanned in such a manner that scanning areas overlap in regions represented by arrows. The positions of the arrows in Fig. 6 are equal to the positions of the arrows in Fig. 5.

[0086] In the comparative example, the initial sound pressure in the direction z of a scanning area is acquired for each main-scanning operation, using formula (1). For a region in the direction z of overlapping scanning areas, the initial sound pressure distribution is acquired by averaging initial sound pressures obtained by main-scanning operations, as in formula (8).

[0087] In the case where the average of initial sound pressures obtained by different weighting factors for main-scanning operations is obtained as described above, the quantity of initial sound pressure may decrease. Thus, at the positions indicated by the arrows in Fig. 6, continuity of the initial sound pressure distribution is decreased compared to the initial sound pressure distribution illustrated in Fig. 5.

(Basic Configuration)

[0088] Hereinafter, the principal configuration of the subject information acquisition device according to this embodiment will be explained.

(Light Source 200)

[0089] Preferably, in order to achieve a photo acoustic effect, the pulse width of light generated by the light source 200 is several hundred nanoseconds or less. Furthermore, for measurement of breast cancer or the like, it is preferable that light having a specific wavelength absorbed by a specific component (for example, hemoglobin) of components constituting a living body is generated. Although it is preferable to use a laser capable of realizing large output as a light source, a light-emitting diode or the like may be used instead of a laser. Various lasers, such as a solid-state laser, a gas laser, a dye laser, or a semiconductor laser, may be used.

(Irradiation Optical System 210)

[0090] The irradiation optical system 210 leads light generated by the light source 200 and irradiates the subject 100 with the irradiation light 211 using a method appropriate for photo acoustic measurement.

[0091] The irradiation optical system 210 may be configured so as to be moved by an optical scanning mechanism 220, as illustrated in Fig. 7. With this configuration, even in the case where an irradiation area of the irradiation light 211

is narrow, a wide area of the subject 100 can be irradiated with the irradiation light 211 by moving the irradiation optical system 210. Furthermore, the irradiation optical system 210 may irradiate the entire measurement region including the subject 100 at a time.

[0092] Since the intensity of photo acoustic waves is proportional to the intensity of light, the irradiation optical system 210 preferably concentrates light energy of the irradiation light 211.

[0093] In order to increase the signal-to-noise (SN) ratio of a reception signal, the irradiation optical system 210 may allow irradiation not only through one surface but also through a plurality of surfaces of the subject 100. For example, the irradiation optical system 210 may be configured to allow irradiation not only through a surface that is in contact with the array transducer 300 but also through a surface that is opposite the array transducer 300.

[0094] The irradiation optical system 210 may include a mirror, a light-collecting lens, a magnifying lens, a shape-changing lens, a prism that diffuses, refracts, and reflects light, or one or more optical fibers. Any other optical components may be used as long as they can irradiate the subject 100 with light generate by a light source in a desired manner (irradiation direction, irradiation field, form, or the like).

(Array Transducer 300)

[0095] The array transducer 300 receives elastic waves and converts the elastic waves into an electric signal. Transducers forming the array transducer 300 may be transducers using a piezoelectric phenomenon, transducers using resonance of light, transducers using a change in capacitance, or the like. Any type of transducer may be used as long as it can receive elastic waves and convert the elastic waves into an electric signal.

[0096] With the use of an array transducer 300 including a plurality of transducers, elastic waves can be received at different positions by a single receiving operation. Thus, compared to the case in which a single transducer is used, the measurement time can be shortened. Furthermore, the direction in which the reception sensitivity is high of at least one element of a plurality of transducers may be directed toward a specific region. Normally, the direction of a normal of the reception surface of a transducer is equal to the direction in which the reception sensitivity is high. For example, as described in Patent Document 2 (U.S. Patent No. 5,713,356), a plurality of transducers may be arranged in a spiral shape on a hemispheric base.

[0097] However, in an aspect of the present invention, elastic waves may be received using a single transducer, instead of using a plurality of transducers.

(Scanning Mechanism 400)

[0098] The scanning mechanism 400 is a mechanism that moves the array transducer 300. With the scanning mechanism 400, the array transducer 300 is capable of receiving elastic waves at different positions.

[0099] In the case where the irradiation optical system 210 is scanned with the optical scanning mechanism 220, it is preferable that scanning of the irradiation optical system 210 and scanning of the array transducer 300 are performed in synchronization with each other. In addition, it is further preferable that the timing at which irradiation with the irradiation light 211 is performed and the timing at which the array transducer 300 receives photo acoustic waves are in synchronization with each other.

[0100] As illustrated in Fig. 1, the scanning mechanism 400 moves the array transducer 300 two-dimensionally. However, movement of the array transducer 300 is not limited to being two-dimensional. The scanning mechanism 400 may move the array transducer 300 three-dimensionally so as to translate and rotate around a subject.

[0101] A moving part used in an aspect of the present invention may be a mechanical moving part like the scanning mechanism 400 according to this embodiment or may be a holding part held by a user so that the user can cause the array transducer 300 to be moved.

(Signal Processing Apparatus 500)

[0102] Preferably, the signal processing apparatus 500 amplifies a reception signal output from the array transducer 300 and converts the reception signal from an analog signal into a digital signal. As used herein, a "reception signal" includes an analog signal output from the array transducer 300 and a digital signal that is analog-to-digital converted by the signal processing apparatus 500.

[0103] The signal processing apparatus 500 acquires an optical characteristic value inside a subject as subject information by performing image reconstruction or the like. Typically, a workstation including one or more microprocessors, or the like, is used as the signal processing apparatus 500. Image reconstruction processing and control of the subject information acquisition device is performed by software programmed in advance and executed by the one or more microprocessors. For example, time-domain back projection is performed as image reconstruction processing by the signal processing apparatus 500, based on known algorithms. Similarly, a subject information acquisition process is

performed by the signal processing apparatus 500, based on the algorithm illustrated in Fig. 3, for example.

[0104] Here, subject information used in an aspect of the present invention is data representing information inside a subject, regardless of whether the data is two-dimensional or three-dimensional. In a subject information acquisition device using a photo acoustic effect, subject information is initial sound pressure distribution, light absorption coefficient distribution, oxygen saturation degree distribution, or the like inside a subject. In a subject information acquisition device using reflected waves of ultrasonic waves, subject information is acoustic impedance distribution, elastic coefficient distribution, or the like inside a subject.

[0105] Furthermore, subject information is configured such that a plurality of pixels, which are the minimum elements, are arranged in the case where the subject information is two-dimensional and that a plurality of voxels, which are the minimum elements, are arranged in the case where the subject information is three-dimensional.

[0106] The signal processing apparatus 500 generates image data by performing processing, such as luminance conversion, on acquired subject information, and outputs the generated image data to the display unit 600. The signal processing apparatus 500 may output the value of subject information in a specific position or region to the display unit 600 and may display the value of the subject information in the specific position or region on the display unit 600.

[0107] Functions of the signal processing apparatus 500 according to this embodiment may be provided as independent devices or modules.

[0108] In the case where a module is configured to be hardware, the module may be configured to be a field programmable gate array (FPGA), an application specific integrated circuit (ASIC), or the like. Modules may be configured to be programs that cause a computer to execute corresponding processes.

(Display Unit 600)

[0109] The display unit 600 displays image information and numerical information of subject information generated by the signal processing apparatus 500. For example, a liquid crystal display or the like may be used as the display unit 600. The display unit 600 may be provided independent of a subject information acquisition device according to this embodiment.

Other Embodiments

[0110] Embodiments of the present invention can also be realized by a computer of a system or apparatus that reads out and executes computer executable instructions recorded on a storage medium (e.g., non-transitory computer-readable storage medium) to perform the functions of one or more of the above-described embodiment(s) of the present invention, and by a method performed by the computer of the system or apparatus by, for example, reading out and executing the computer executable instructions from the storage medium to perform the functions of one or more of the above-described embodiment(s). The computer may comprise one or more of a central processing unit (CPU), micro processing unit (MPU),

or other circuitry, and may include a network of separate computers or separate computer processors. The computer executable instructions may be provided to the computer, for example, from a network or the storage medium. The storage medium may include, for example, one or more of a hard disk, a random-access memory (RAM), a read only memory (ROM), a storage of distributed computing systems, an optical disk (such as a compact disc (CD), digital versatile disc (DVD), or Blu-ray Disc (BD)[™]), a flash memory device, a memory card, and the like.

[0111] Although preferred embodiments of the present invention have been explained above, the present invention is not limited to the foregoing embodiments.

A subject information acquisition device includes elastic wave receiving means (300) configured to receive elastic waves generated inside a subject and output a reception signal; and signal processing means (500) configured to acquire subject information in an interest region of the subject, on the basis of the reception signal. In measurement states, the elastic wave receiving means receives elastic waves and outputs reception signals corresponding to the measurement states. The signal processing means corrects the reception signals by weighting factors based on measurement parameters in the measurement states, and acquires corrected reception signals in the interest region corresponding to the measurement states. The signal processing means acquires the subject information in the interest region, on the basis of the sum of the corrected reception signals and the sum of the weighting factors.

Claims

1. A subject information acquisition device comprising:

elastic wave receiving means (300) configured to receive elastic waves generated from a subject and output a

reception signal; and
 signal processing means (500) configured to acquire subject information of an interest region on the basis of
 the reception signal,
characterized by:

5

moving means (400) configured to move the elastic wave receiving means (300) to a plurality of different
 positions to form a first scanning area (310) and a second scanning area (320) and form an overlap area
 (330) which is an area where the first scanning area and the second scanning area partially overlap; and
 wherein the interest region (110) is a specific position in the overlap area (330),

10

wherein, at a first plurality of different positions included in the first scanning area, the elastic wave receiving
 means receives elastic waves and outputs a first plurality of reception signals corresponding to the first plurality
 of different positions,

15

wherein, at a second plurality of different positions included in the second scanning area, the elastic wave
 receiving means receives elastic waves and outputs a second plurality of reception signals corresponding to
 the second plurality of different positions,

20

wherein the signal processing means acquires a first plurality of corrected reception signals corresponding to
 the first plurality of different positions by correcting the first plurality of reception signals with a first plurality of
 weighting factors determined based on a first plurality of measurement parameters corresponding to the first
 plurality of different positions and a position of the interest region and acquires a first sum of the first plurality
 of corrected reception signals,

25

wherein the signal processing means acquires a second plurality of corrected reception signals corresponding
 to the second plurality of different positions by correcting the second plurality of reception signals with a second
 plurality of weighting factors determined based on a second plurality of measurement parameters corresponding
 to the second plurality of different positions and a position of the interest region and acquires a second sum of
 the second plurality of corrected reception signals, and

30

wherein the signal processing means acquires the subject information of the interest region on the basis of a
 sum of the first sum and the second sum, and a sum of the first plurality of weighting factors and the second
 plurality of weighting factors.

2. The subject information acquisition device according to Claim 1,
 wherein the signal processing means acquires the subject information of the interest region by acquiring the ratio
 of the sum of the first sum and the second sum to the sum of the first plurality of weighting factors and the second
 plurality of weighting factors.

35

3. The subject information acquisition device according to Claim 1 or 2,
 wherein in the plurality of different positions, the elastic wave receiving means is capable of receiving elastic waves
 at reception surfaces whose angles relative to the interest region are different.

40

4. The subject information acquisition device according to any one of Claims 1 to 3,
 wherein the first or the second plurality of weighting factors are each a factor based on the solid angle of a cone
 whose vertex is the interest region and whose bottom surface is a reception surface of the elastic wave receiving
 means in a corresponding one of the first or the second plurality of different positions.

45

5. The subject information acquisition device according to any one of Claims 1 to 4,
 wherein the elastic wave receiving means includes a plurality of transducers.

50

6. The subject information acquisition device according to Claim 5,
 wherein the elastic wave receiving means is configured in such a manner that a direction in which reception sensitivity
 is high of at least one element of the plurality of transducers is directed toward a specific region.

7. The subject information acquisition device according to Claim 5 or 6,
 wherein the signal processing unit is configured to select a transducer to be used among the plurality of transducers.

55

8. The subject information acquisition device according to any one of Claims 1 to 7,
 wherein the elastic waves are photoacoustic waves generated by irradiating the subject with light.

9. The subject information acquisition device according to Claim 8,

wherein the signal processing means performs a process including differentiation processing on the first or the second plurality of reception signals and corrects, with the first or the second plurality of weighting factors, the first or the second plurality of reception signals that have been subjected to the differentiation processing.

5 10. The subject information acquisition device according to any one of Claims 1 to 6,
wherein the elastic waves are reflected waves of ultrasonic waves generated when the ultrasonic waves transmitted to the subject are reflected inside the subject.

10 11. The subject information acquisition device according to any one of Claims 1 to 10,
wherein the moving means (400) comprises a main-scanning mechanism (410) for moving the elastic wave receiving means (300) along a main-scanning direction and a sub-scanning mechanism (420) for moving the elastic wave receiving means (300) along a sub-scanning direction perpendicular to the main-scanning direction, and wherein the main-scanning mechanism (410) is configured to move the elastic wave receiving means (300) to form a plurality of main-scanning areas including the first scanning area and the second scanning area and the sub-scanning mechanism (420) is configured to move the elastic wave receiving means (300) to form the overlap area (330).
15

12. The subject information acquisition device according to any one of Claims 1 to 11,
wherein the signal processing means acquires the subject information of the interest region, by dividing the sum of the first sum and the second sum by the sum of the first plurality of weighting factors and the second plurality of weighting factors.
20

13. A method for controlling a subject information acquisition device, the method comprising the steps of:

25 receiving elastic waves generated from a subject at a first plurality of different positions included in a first area (310) and outputting a first plurality of reception signals corresponding to the first plurality of different positions; receiving elastic waves generated from a subject at a second plurality of different positions included in a second area (320) and outputting a second plurality of reception signals corresponding to the second plurality of different positions, wherein the first area (310) and the second area (320) form an overlap area (330) which is an area where the first area and the second area partially overlap;

30 acquiring a first plurality of corrected reception signals corresponding to the first plurality of different positions by correcting the first plurality of reception signals with a first plurality of weighting factors determined based on a first plurality of measurement parameters corresponding to the first plurality of different positions and a position of the interest region,
acquiring a first sum of the first plurality of corrected reception signals;

35 acquiring a second plurality of corrected reception signals corresponding to the second plurality of different positions by correcting the second plurality of reception signals with a second plurality of weighting factors determined based on a second plurality of measurement parameters corresponding to the second plurality of different positions and a position of the interest region;

40 acquiring a second sum of the second plurality of corrected reception signals; and
acquiring subject information of the interest region, on the basis of a sum of the first sum and the second sum, and a sum of the first plurality of weighting factors and the second plurality of weighting factors.

14. A program that causes a computer to execute the method according to Claim 13.

45

Patentansprüche

1. Subjektinformationsbeschaffungsvorrichtung mit einer Elastikwellenempfangseinrichtung (300) zum Empfangen von von einem Subjekt erzeugten elastischen Wellen und zur Ausgabe eines Empfangssignals und einer Signalverarbeitungseinrichtung (500) zur Beschaffung von Subjektinformationen einer interessierenden Region auf der Grundlage des Empfangssignals,
gekennzeichnet durch
eine Bewegungseinrichtung (400) zur Bewegung der Elastikwellenempfangseinrichtung (300) an eine Vielzahl verschiedener Positionen zur Erzeugung eines ersten Abtastbereichs (310) und eines zweiten Abtastbereichs (320) und Erzeugung eines Überlappungsbereichs (330), der einen Bereich darstellt, wo der erste Abtastbereich und der zweite Abtastbereich teilweise überlappen, und wobei die interessierende Region (110) eine bestimmte Position im Überlappungsbereich (330) ist,
55

wobei die Elastikwellenempfangseinrichtung an einer ersten Vielzahl verschiedener Positionen, die in dem ersten Abtastbereich enthalten sind, elastische Wellen empfängt und eine erste Vielzahl von Empfangssignalen ausgibt, die der ersten Vielzahl verschiedener Positionen entspricht,

wobei die Elastikwellenempfangseinrichtung an einer zweiten Vielzahl verschiedener Positionen, die in dem zweiten Abtastbereich enthalten sind, elastische Wellen empfängt und eine zweite Vielzahl von Empfangssignalen ausgibt, die der zweiten Vielzahl verschiedener Positionen entspricht,

wobei die Signalverarbeitungseinrichtung eine erste Vielzahl korrigierter Empfangssignale, die der ersten Vielzahl verschiedener Positionen entspricht, durch Korrigieren der ersten Vielzahl von Empfangssignalen mit einer ersten Vielzahl von Gewichtungsfaktoren beschafft, die beruhend auf einer ersten Vielzahl von Messparametern, die der ersten Vielzahl verschiedener Positionen entspricht, und einer Position der interessierenden Region bestimmt werden, und eine erste Summe der ersten Vielzahl korrigierter Empfangssignale beschafft,

wobei die Signalverarbeitungseinrichtung eine zweite Vielzahl korrigierter Empfangssignale, die der zweiten Vielzahl verschiedener Positionen entspricht, durch Korrigieren der zweiten Vielzahl von Empfangssignalen mit einer zweiten Vielzahl von Gewichtungsfaktoren beschafft, die beruhend auf einer zweiten Vielzahl von Messparametern, die der zweiten Vielzahl verschiedener Positionen entspricht, und einer Position der interessierenden Region bestimmt werden, und eine zweite Summe der zweiten Vielzahl korrigierter Empfangssignale beschafft, und

wobei die Signalverarbeitungseinrichtung die Subjektinformationen der interessierenden Region auf der Grundlage einer Summe der ersten Summe und der zweiten Summe und einer Summe der ersten Vielzahl von Gewichtungsfaktoren und der zweiten Vielzahl von Gewichtungsfaktoren beschafft.

2. Subjektinformationsbeschaffungsvorrichtung nach Anspruch 1, wobei die Signalverarbeitungseinrichtung die Subjektinformationen der interessierenden Region durch Beschaffen des Verhältnisses der Summe der ersten Summe und der zweiten Summe zu der Summe der ersten Vielzahl von Gewichtungsfaktoren und der zweiten Vielzahl von Gewichtungsfaktoren beschafft.

3. Subjektinformationsbeschaffungsvorrichtung nach Anspruch 1 oder 2, wobei die Elastikwellenempfangseinrichtung an der Vielzahl verschiedener Positionen elastische Wellen an Empfangsoberflächen empfangen kann, deren Winkel relativ zu der interessierenden Region verschieden sind.

4. Subjektinformationsbeschaffungsvorrichtung nach einem der Ansprüche 1 bis 3, wobei die erste oder die zweite Vielzahl von Gewichtungsfaktoren jeweils ein Faktor ist, der auf dem räumlichen Winkel eines Kegels beruht, dessen Spitze die interessierende Region ist, und dessen Grundfläche eine Empfangsoberfläche der Elastikwellenempfangseinrichtung an einer entsprechenden der ersten oder der zweiten Vielzahl verschiedener Positionen ist.

5. Subjektinformationsbeschaffungsvorrichtung nach einem der Ansprüche 1 bis 4, wobei die Elastikwellenempfangseinrichtung eine Vielzahl von Signalgebern ist.

6. Subjektinformationsbeschaffungsvorrichtung nach Anspruch 5, wobei die Elastikwellenempfangseinrichtung derart eingerichtet ist, dass eine Richtung, in der die Empfangsempfindlichkeit zumindest eines Elements der Vielzahl der Signalgeber hoch ist, zu einer bestimmten Region gerichtet ist.

7. Subjektinformationsbeschaffungsvorrichtung nach Anspruch 5 oder 6, wobei die Signalverarbeitungseinheit zum Auswählen eines zu verwendenden Signalgebers unter der Vielzahl der Signalgeber eingerichtet ist.

8. Subjektinformationsbeschaffungsvorrichtung nach einem der Ansprüche 1 bis 7, wobei die elastischen Wellen durch Bestrahlung des Subjekts mit Licht erzeugte fotoakustische Wellen sind.

9. Subjektinformationsbeschaffungsvorrichtung nach Anspruch 8, wobei die Signalverarbeitungseinrichtung einen Prozess durchführt, der eine Ableitungsverarbeitung bei der ersten oder der zweiten Vielzahl von Empfangssignalen enthält, und mit der ersten oder der zweiten Vielzahl der Gewichtungsfaktoren die erste oder die zweite Vielzahl der Empfangssignale korrigiert, die der Ableitungsverarbeitung unterzogen wurden.

10. Subjektinformationsbeschaffungsvorrichtung nach einem der Ansprüche 1 bis 6, wobei die elastischen Wellen reflektierte Wellen von Ultraschallwellen sind, die erzeugt werden, wenn die zu dem Subjekt übertragenen Ultraschallwellen im Subjekt reflektiert werden.

11. Subjektinformationsbeschaffungsvorrichtung nach einem der Ansprüche 1 bis 10, wobei die Bewegungseinrichtung (400) eine Hauptabtasteinrichtung (410) zur Bewegung der Elastikwellenempfangseinrichtung (300) entlang einer

Hauptabtastrichtung und eine Nebenabtasteinrichtung (420) zur Bewegung der Elastikwellenempfangseinrichtung (300) entlang einer Nebenabtastrichtung senkrecht zur Hauptabtastrichtung umfasst, und wobei die Hauptabtasteinrichtung (410) zur Bewegung der Elastikwellenempfangseinrichtung (300) zur Erzeugung einer Vielzahl von Hauptabtaastbereichen mit dem ersten Abtaastbereich und dem zweiten Abtaastbereich eingerichtet ist, und die Nebenabtasteinrichtung (420) zur Bewegung der Elastikwellenempfangseinrichtung (300) zur Erzeugung des Überlappungsbereichs (330) eingerichtet ist.

12. Subjektinformationsbeschaffungsvorrichtung nach einem der Ansprüche 1 bis 11, wobei die Signalverarbeitungseinrichtung die Subjektinformationen der interessierenden Region durch Teilen der Summe der ersten Summe und der zweiten Summe durch die Summe der ersten Vielzahl von Gewichtungsfaktoren und der zweiten Vielzahl von Gewichtungsfaktoren beschafft.

13. Verfahren zur Steuerung einer Subjektinformationsbeschaffungsvorrichtung, wobei das Verfahren die Schritte umfasst:

Empfangen elastischer Wellen, die von einem Subjekt erzeugt werden, an einer ersten Vielzahl verschiedener Positionen, die in einem ersten Bereich (310) enthalten sind, und Ausgeben einer ersten Vielzahl von Empfangssignalen, die der ersten Vielzahl verschiedener Positionen entspricht,

Empfangen elastischer Wellen, die von einem Subjekt erzeugt werden, an einer zweiten Vielzahl verschiedener Positionen, die in einem zweiten Bereich (320) enthalten sind, und Ausgeben einer zweiten Vielzahl von Empfangssignalen, die der zweiten Vielzahl verschiedener Positionen entspricht, wobei der erste Bereich (310) und der zweite Bereich (320) einen Überlappungsbereich (330) bilden, der einen Bereich darstellt, wo der erste Bereich und der zweite Bereich teilweise überlappen,

Beschaffen einer ersten Vielzahl korrigierter Empfangssignale, die der ersten Vielzahl verschiedener Positionen entspricht, durch Korrigieren der ersten Vielzahl von Empfangssignalen mit einer ersten Vielzahl von Gewichtungsfaktoren, die beruhend auf einer ersten Vielzahl von Messparametern, die der ersten Vielzahl verschiedener Positionen entspricht, und einer Position der interessierenden Region bestimmt werden,

Beschaffen einer ersten Summe der ersten Vielzahl korrigierter Empfangssignale,

Beschaffen einer zweiten Vielzahl korrigierter Empfangssignale, die der zweiten Vielzahl verschiedener Positionen entspricht, durch Korrigieren der zweiten Vielzahl von Empfangssignalen mit einer zweiten Vielzahl von Gewichtungsfaktoren, die beruhend auf einer zweiten Vielzahl von Messparametern, die der zweiten Vielzahl verschiedener Positionen entspricht, und einer Position der interessierenden Region bestimmt werden,

Beschaffen einer zweiten Summe der zweiten Vielzahl korrigierter Empfangssignale und

Beschaffen von Subjektinformationen der interessierenden Region auf der Grundlage einer Summe der ersten Summe und der zweiten Summe und einer Summe der ersten Vielzahl von Gewichtungsfaktoren und der zweiten Vielzahl von Gewichtungsfaktoren.

14. Programm, das einen Computer zur Ausführung des Verfahrens nach Anspruch 13 veranlasst.

Revendications

1. Dispositif d'acquisition d'informations de sujet comprenant :

des moyens de réception d'onde élastique (300) configurés pour recevoir des ondes élastiques générées à partir d'un sujet et sortir un signal de réception ; et

des moyens de traitement de signal (500) configurés pour acquérir des informations de sujet d'une région d'intérêt sur la base du signal de réception,

caractérisé par :

des moyens de déplacement (400) configurés pour déplacer les moyens de réception d'onde élastique (300) vers une pluralité de positions différentes pour former une première zone de balayage (310) et une seconde zone de balayage (320) et former une zone de chevauchement (330) qui est une zone où la première zone de balayage et la seconde zone de balayage se chevauchent partiellement ; et

dans lequel la région d'intérêt (110) est une position spécifique dans la zone de chevauchement (330), dans lequel, à une première pluralité de positions différentes incluses dans la première zone de balayage, les moyens de réception d'onde élastique reçoivent des ondes élastiques et sortent une première pluralité de signaux de réception correspondant à la première pluralité de positions différentes,

EP 2 740 410 B1

- dans lequel, à une seconde pluralité de positions différentes incluses dans la seconde zone de balayage, les moyens de réception d'onde élastique reçoivent des ondes élastiques et sortent une seconde pluralité de signaux de réception correspondant à la seconde pluralité de positions différentes,
- 5 dans lequel les moyens de traitement de signal acquièrent une première pluralité de signaux de réception corrigés correspondant à la première pluralité de positions différentes en corrigeant la première pluralité de signaux de réception avec une première pluralité de facteurs de pondération déterminée sur la base d'une première pluralité de paramètres de mesure correspondant à la première pluralité de positions différentes et à une position de la région d'intérêt et acquièrent une première somme de la première pluralité de signaux de réception corrigés,
- 10 dans lequel les moyens de traitement de signal acquièrent une seconde pluralité de signaux de réception corrigés correspondant à la seconde pluralité de positions différentes en corrigeant la seconde pluralité de signaux de réception avec une seconde pluralité de facteurs de pondération déterminée sur la base d'une seconde pluralité de paramètres de mesure correspondant à la seconde pluralité de positions différentes et à une position de la région d'intérêt et acquièrent une seconde somme de la seconde pluralité de signaux de réception corrigés, et
- 15 dans lequel les moyens de traitement de signal acquièrent les informations de sujet de la région d'intérêt sur la base d'une somme de la première somme et de la seconde somme, et d'une somme de la première pluralité de facteurs de pondération et de la seconde pluralité de facteurs de pondération.
- 20 **2.** Dispositif d'acquisition d'informations de sujet selon la revendication 1, dans lequel les moyens de traitement de signal acquièrent les informations de sujet de la région d'intérêt en acquérant le rapport de la somme de la première somme et de la seconde somme sur la somme de la première pluralité de facteurs de pondération et de la seconde pluralité de facteurs de pondération.
- 25 **3.** Dispositif d'acquisition d'informations de sujet selon la revendication 1 ou 2, dans lequel dans la pluralité de positions différentes, les moyens de réception d'onde élastique sont capables de recevoir des ondes élastiques au niveau de surfaces de réception dont les angles par rapport à la région d'intérêt sont différents.
- 30 **4.** Dispositif d'acquisition d'informations de sujet selon l'une quelconque des revendications 1 à 3, dans lequel la première ou la seconde pluralité de facteurs de pondération sont chacun un facteur basé sur l'angle solide d'un cône dont le sommet est la région d'intérêt et dont la surface inférieure est une surface de réception des moyens de réception d'onde élastique dans l'une correspondante de la première ou de la seconde pluralité de positions différentes.
- 35 **5.** Dispositif d'acquisition d'informations de sujet selon l'une quelconque des revendications 1 à 4, dans lequel les moyens de réception d'onde élastique incluent une pluralité de transducteurs.
- 40 **6.** Dispositif d'acquisition d'informations de sujet selon la revendication 5, dans lequel les moyens de réception d'onde élastique sont configurés de telle manière qu'une direction dans laquelle la sensibilité de réception est élevée d'au moins un élément de la pluralité de transducteurs soit dirigée vers une région spécifique.
- 45 **7.** Dispositif d'acquisition d'informations de sujet selon la revendication 5 ou 6, dans lequel l'unité de traitement de signal est configurée pour sélectionner un transducteur à utiliser parmi la pluralité de transducteurs.
- 8.** Dispositif d'acquisition d'informations de sujet selon l'une quelconque des revendications 1 à 7, dans lequel les ondes élastiques sont des ondes photoacoustiques générées en irradiant le sujet avec une lumière.
- 50 **9.** Dispositif d'acquisition d'informations de sujet selon la revendication 8, dans lequel les moyens de traitement de signal effectuent un processus incluant un traitement de différentiation sur la première ou la seconde pluralité de signaux de réception et corrigent, avec la première ou la seconde pluralité de facteurs de pondération, la première ou la seconde pluralité de signaux de réception qui ont été soumis au traitement de différentiation.
- 55 **10.** Dispositif d'acquisition d'informations de sujet selon l'une quelconque des revendications 1 à 6, dans lequel les ondes élastiques sont des ondes réfléchies d'ondes ultrasoniques générées lorsque les ondes

ultrasoniques transmises au sujet sont réfléchies à l'intérieur du sujet.

5 11. Dispositif d'acquisition d'informations de sujet selon l'une quelconque des revendications 1 à 10,
dans lequel les moyens de réception (400) comprennent un mécanisme de balayage principal (410) pour déplacer
les moyens de réception d'onde élastique (300) le long d'une direction de balayage principal et un mécanisme de
sous-balayage (420) pour déplacer les moyens de réception d'onde élastique (300) le long d'une direction de sous-
balayage perpendiculaire à la direction de balayage principal, et dans lequel le mécanisme de balayage principal
10 (410) est configuré pour déplacer les moyens de réception d'onde élastique (300) pour former une pluralité de zones
de balayage principal incluant la première zone de balayage et la seconde zone de balayage et le mécanisme de
sous-balayage (420) est configuré pour déplacer les moyens de réception d'onde élastique (300) pour former la
zone de chevauchement (330).

15 12. Dispositif d'acquisition d'informations de sujet selon l'une quelconque des revendications 1 à 11,
dans lequel les moyens de traitement de signal acquièrent les informations de sujet de la région d'intérêt, en divisant
la somme de la première somme et de la seconde somme par la somme de la première pluralité de facteurs de
pondération et de la seconde pluralité de facteurs de pondération.

20 13. Procédé pour commander un dispositif d'acquisition d'informations de sujet, le procédé comprenant les étapes
consistant à :

recevoir des ondes élastiques générées à partir d'un sujet à une première pluralité de positions différentes
incluses dans une première zone (310) et sortir une première pluralité de signaux de réception correspondant
à la première pluralité de positions différentes ;

25 recevoir des ondes élastiques générées à partir d'un sujet à une seconde pluralité de positions différentes
incluses dans une seconde zone (320) et sortir une seconde pluralité de signaux de réception correspondant
à la seconde pluralité de positions différentes, où la première zone (310) et la seconde zone (320) forment une
zone de chevauchement (330) qui est une zone où la première zone et la seconde zone se chevauchent
partiellement ;

30 acquérir une première pluralité de signaux de réception corrigés correspondant à la première pluralité de po-
sitions différentes en corrigeant la première pluralité de signaux de réception avec une première pluralité de
facteurs de pondération déterminée sur la base d'une première pluralité de paramètres de mesure correspondant
à la première pluralité de positions différentes et à une position de la région d'intérêt,

acquérir une première somme de la première pluralité de signaux de réception corrigés ;

35 acquérir une seconde pluralité de signaux de réception corrigés correspondant à la seconde pluralité de positions
différentes en corrigeant la seconde pluralité de signaux de réception avec une seconde pluralité de facteurs
de pondération déterminée sur la base d'une seconde pluralité de paramètres de mesure correspondant à la
seconde pluralité de positions différentes et à une position de la région d'intérêt ;

acquérir une seconde somme de la seconde pluralité de signaux de réception corrigés ; et

40 acquérir des informations de sujet de la région d'intérêt, sur la base d'une somme de la première somme et de
la seconde somme, et d'une somme de la première pluralité de facteurs de pondération et de la seconde pluralité
de facteurs de pondération.

45 14. Programme qui amène un ordinateur à exécuter le procédé selon la revendication 13.

50

55

FIG. 1

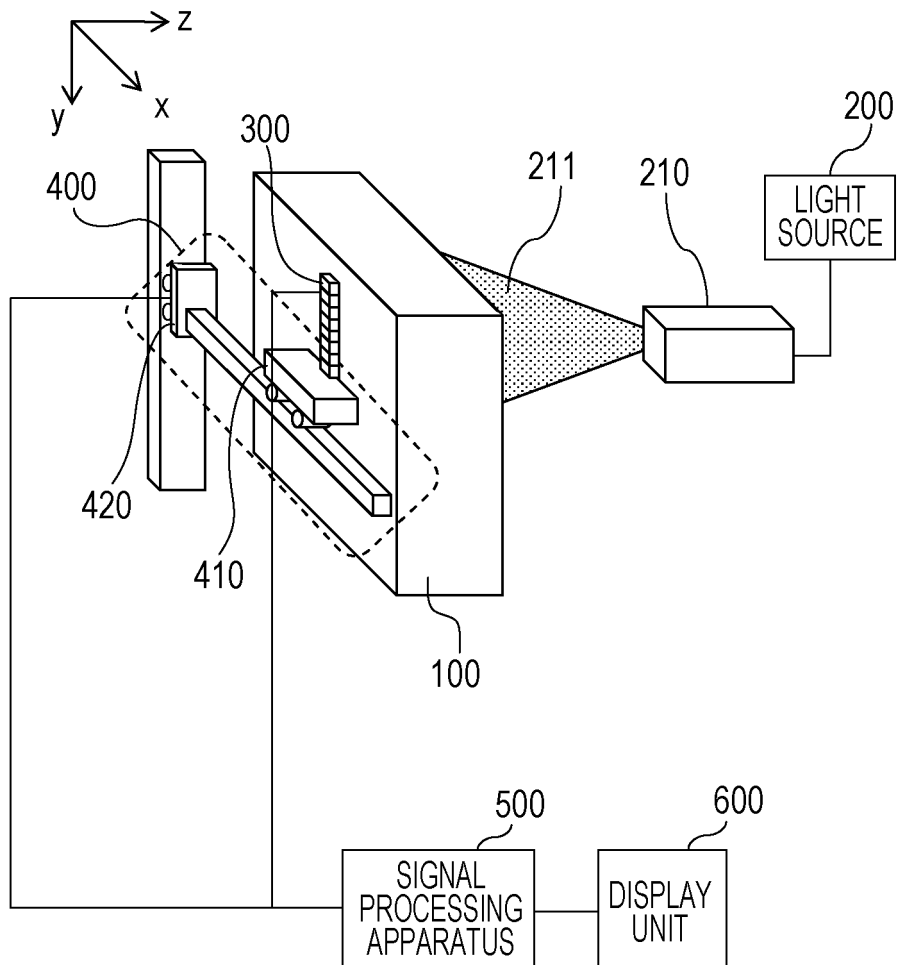

FIG. 2

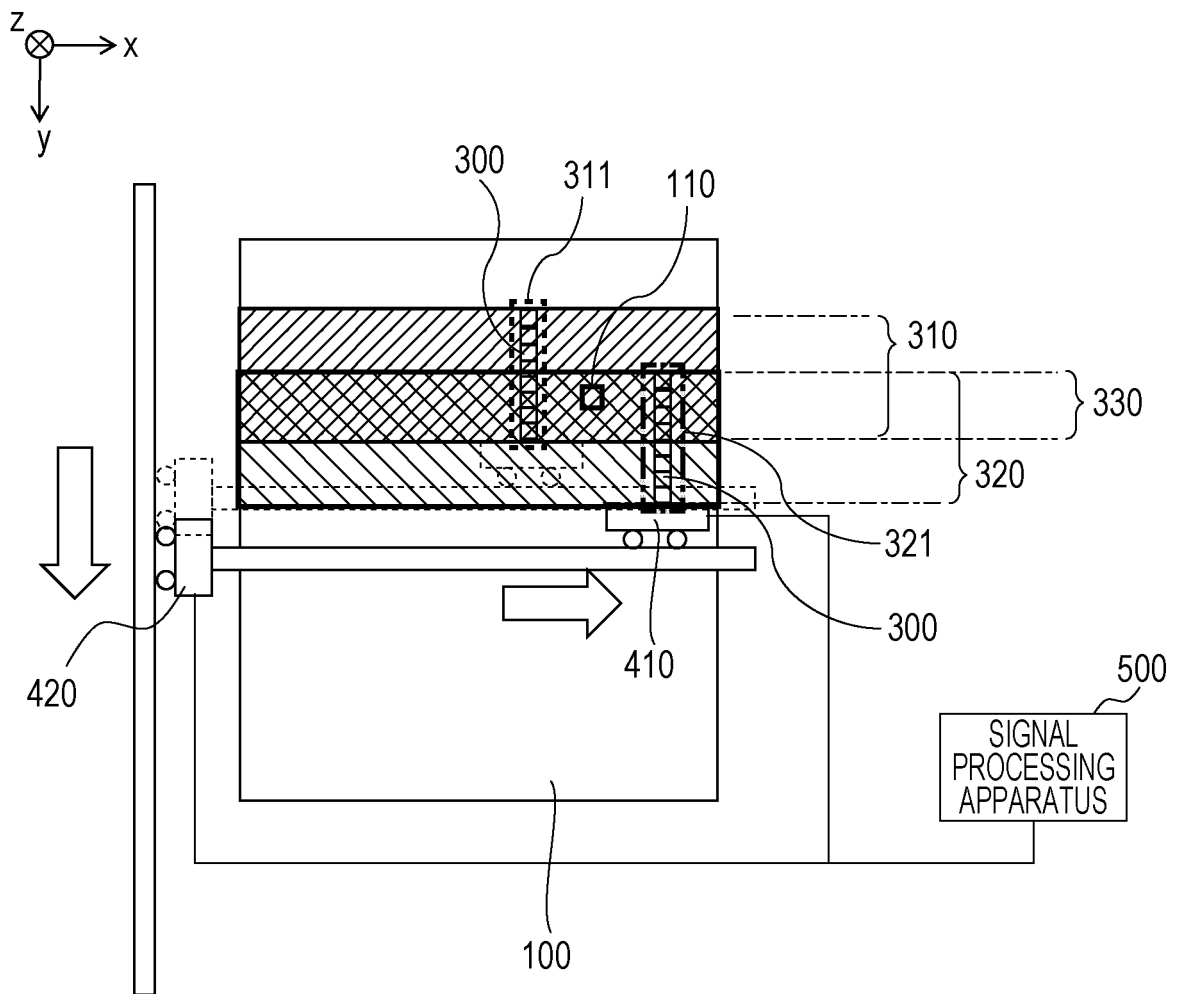

FIG. 3

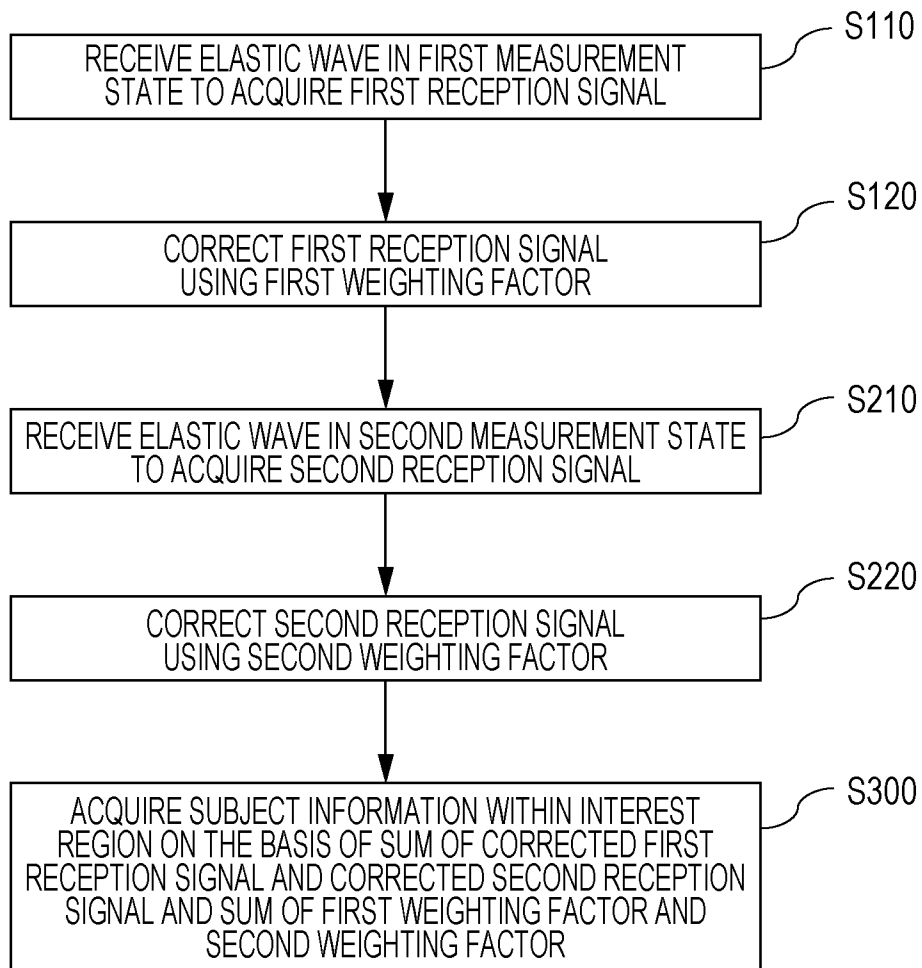

FIG. 4A

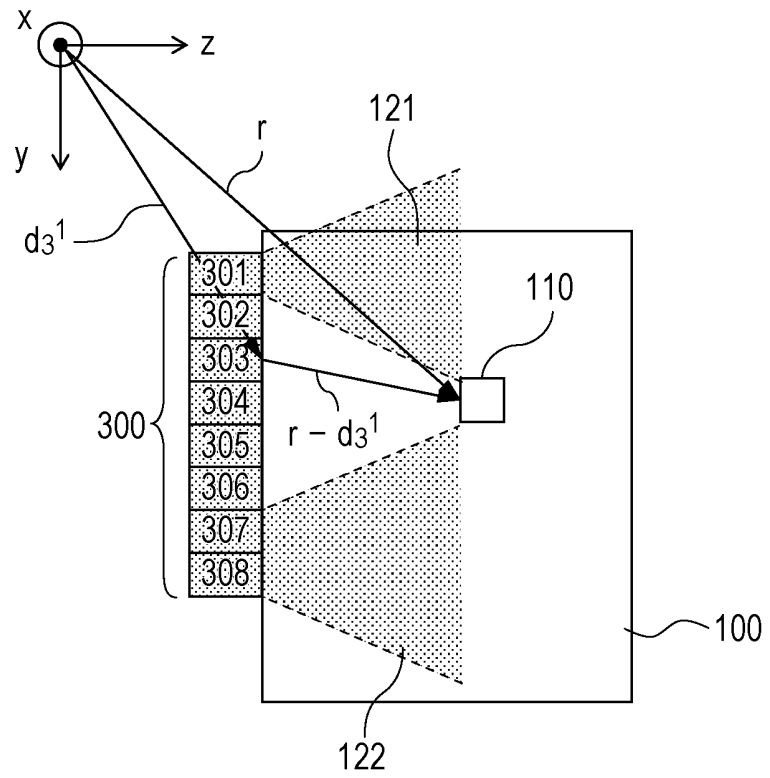

FIG. 4B

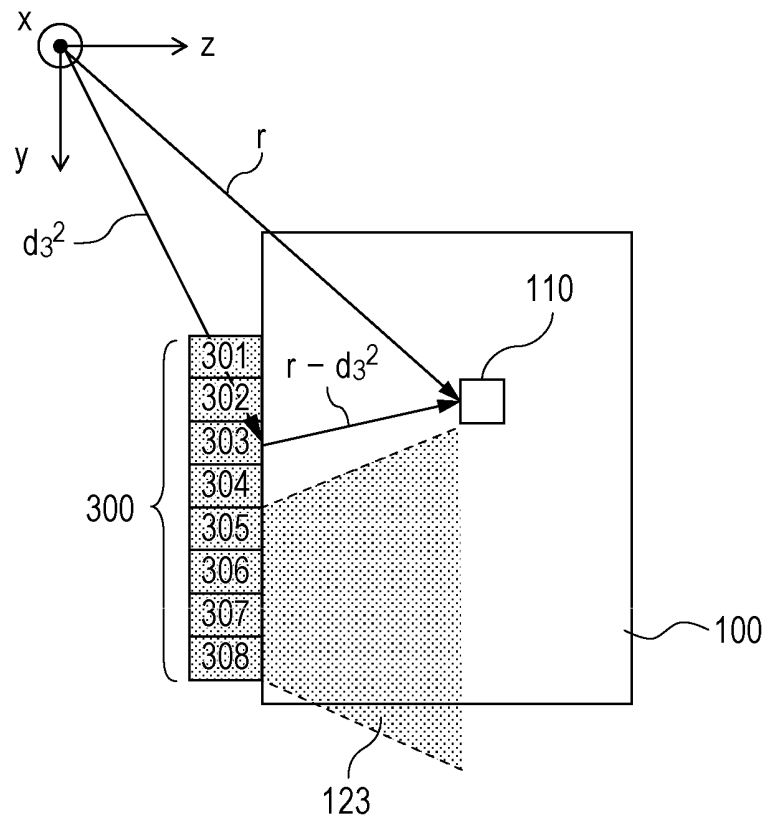

FIG. 5

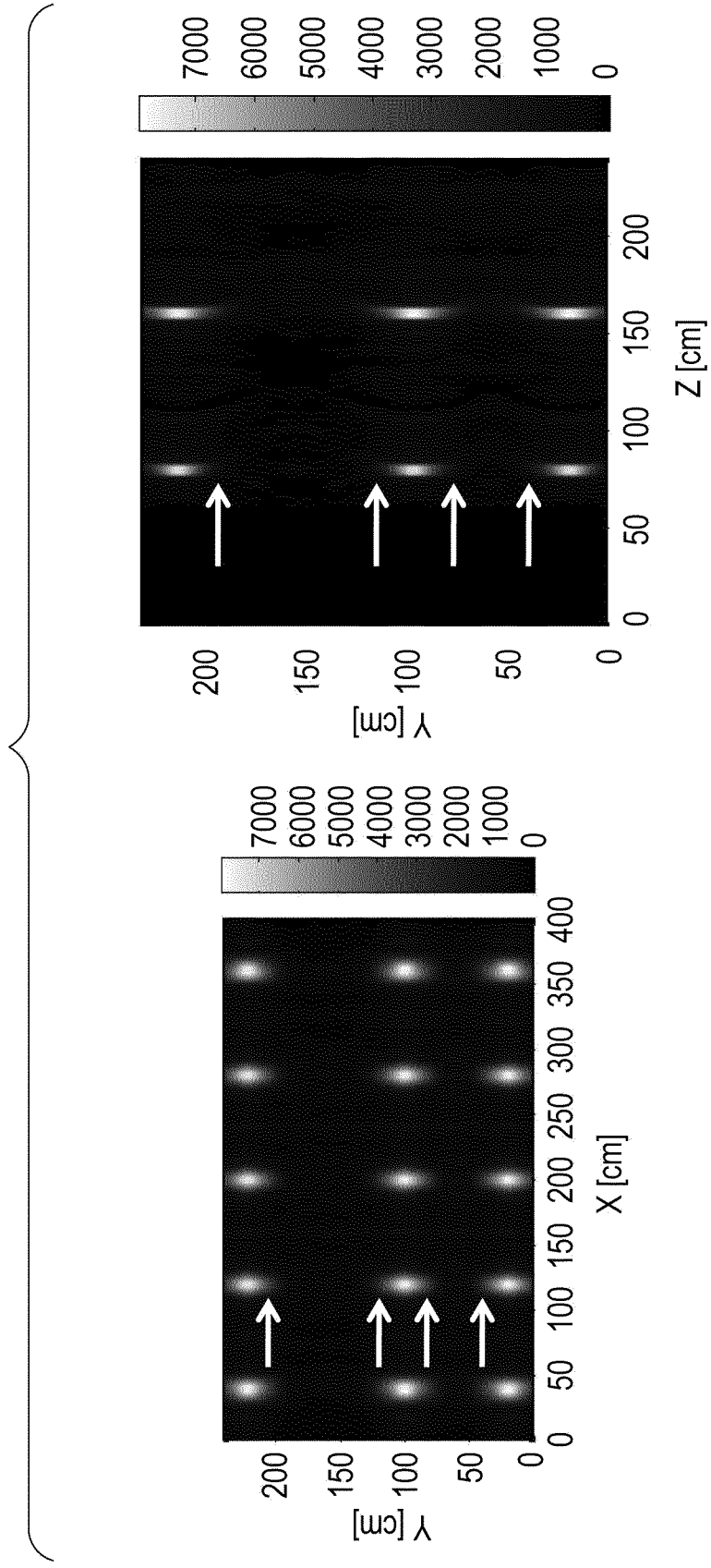

FIG. 6

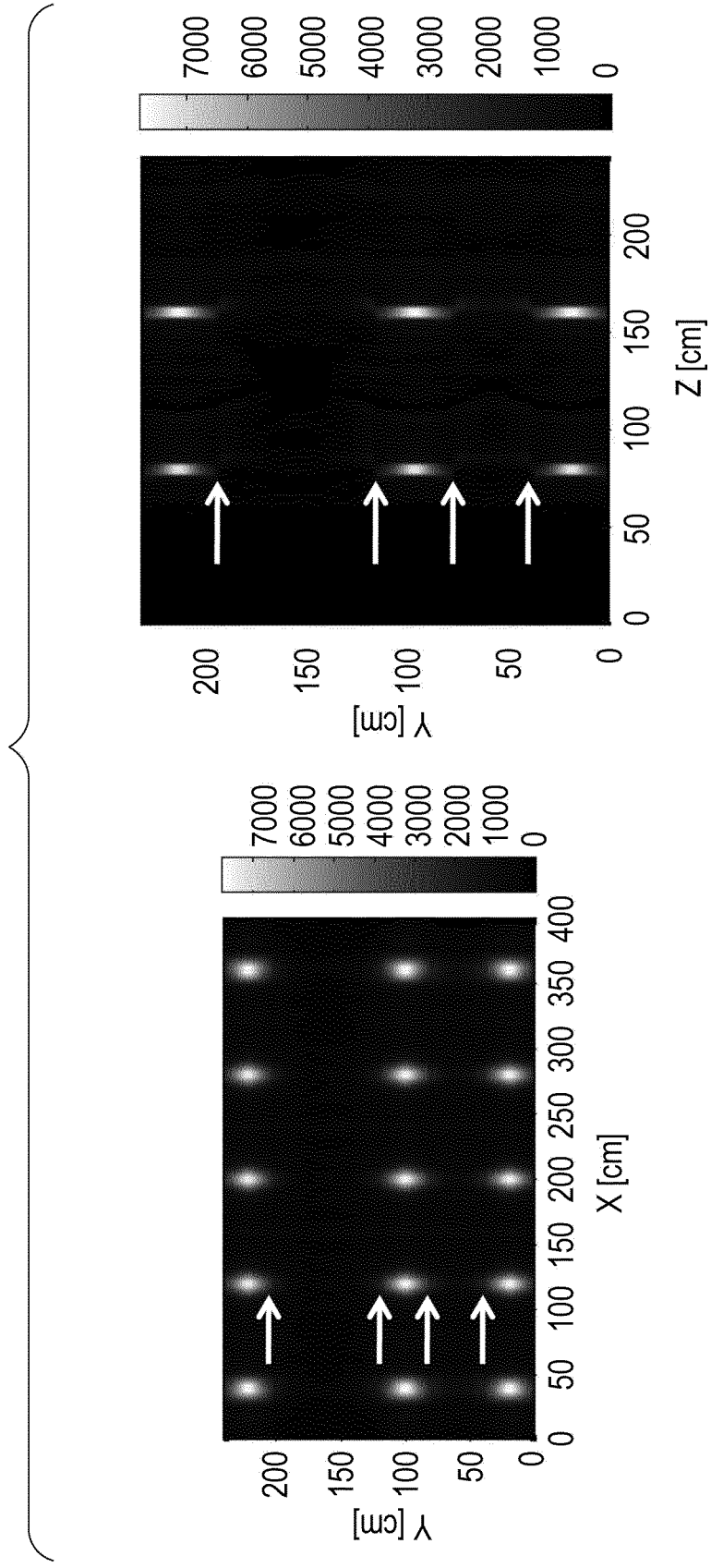

FIG. 7

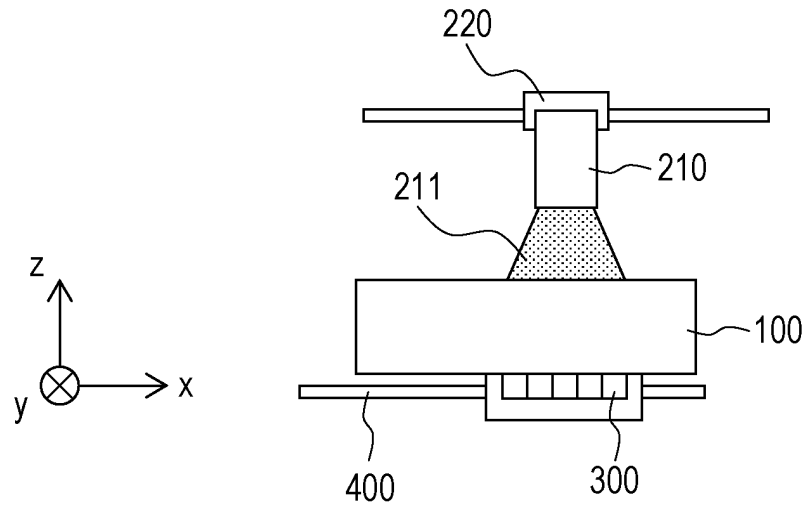
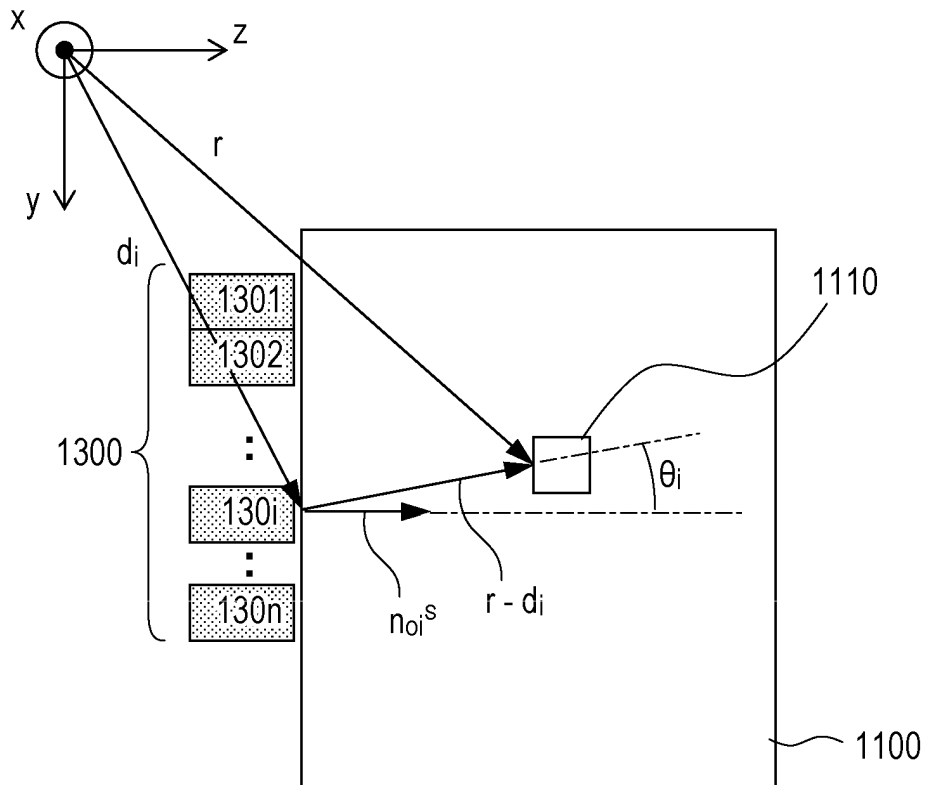

FIG. 8



REFERENCES CITED IN THE DESCRIPTION

This list of references cited by the applicant is for the reader's convenience only. It does not form part of the European patent document. Even though great care has been taken in compiling the references, errors or omissions cannot be excluded and the EPO disclaims all liability in this regard.

Patent documents cited in the description

- JP 2010104816 A [0014]
- US 20110128816 A [0018]
- US 20110251475 A1 [0016]
- US 5713356 A [0096]

Non-patent literature cited in the description

- Initial results of in vivo non-invasive cancer imaging in the human breast using near-infrared photoacoustics. **SRIRANG MANOHAR et al.** OPTICS EXPRESS. OSA (OPTICAL SOCIETY OF AMERICA, 12 September 2007, vol. 15, 12277-12285 [0017]
- **LAMELA HORACIO et al.** Reconstruction algorithm for optoacoustic imaging based on fiber optic detectors. *INDEPENDENT COMPONENT ANALYSES, WAVELETS, NEURAL NETWORKS, BIOSYSTEMS, AND NANOENGINEERING IX, SPIE* [0017]
- 1000 20th ST. BELLINGHAM WA 98225-6705 USA, 13 May 2011, vol. 8058, 1-7 [0017]

专利名称(译)	主题信息获取设备，用于控制主题信息获取设备的方法及其程序		
公开(公告)号	EP2740410B1	公开(公告)日	2018-05-16
申请号	EP2013191035	申请日	2013-10-31
[标]申请(专利权)人(译)	佳能株式会社		
申请(专利权)人(译)	佳能株式会社		
当前申请(专利权)人(译)	佳能株式会社		
[标]发明人	NANAUMI RYUICHI		
发明人	NANAUMI, RYUICHI		
IPC分类号	A61B8/08 A61B5/00		
CPC分类号	A61B5/0095 A61B5/7235 A61B5/7239 A61B5/742 A61B8/0825 A61B8/4209 A61B8/485 A61B8/5207		
代理机构(译)	TBK		
优先权	2012265322 2012-12-04 JP		
其他公开文献	EP2740410A1		
外部链接	Espacenet		

摘要(译)

被检体信息取得装置具备：弹性波接收单元（300），其接收在被检体内产生的弹性波并输出接收信号；以及信号处理装置（500），被配置为基于接收信号来获取对象的感兴趣区域中的对象信息。在测量状态下，弹性波接收装置接收弹性波并输出对应于测量状态的接收信号。信号处理装置根据测量状态下的测量参数通过加权因子校正接收信号，并且获取与测量状态对应的感兴趣区域中的校正接收信号。信号处理装置基于校正的接收信号的总和和加权因子的总和来获取感兴趣区域中的对象信息。

$$p_0(t) = \frac{\sum_{\Omega_1} \sum_{\Omega_2} x(t) \cdot d_{\Omega_1, \Omega_2} \cdot \left(\frac{d_{\Omega_1, \Omega_2} - 1}{V} \right)}{\sum_{\Omega_1} \sum_{\Omega_2} \Omega_{\Omega_1, \Omega_2}} \quad \text{Formula (1)}$$