

(19)



(11)

EP 2 510 382 B1

(12)

EUROPEAN PATENT SPECIFICATION

(45) Date of publication and mention of the grant of the patent:
11.04.2018 Bulletin 2018/15

(51) Int Cl.:
G01S 7/52 ^(2006.01) **G01S 7/527** ^(2006.01)
G01S 15/89 ^(2006.01) **A61B 5/00** ^(2006.01)
A61B 8/14 ^(2006.01)

(21) Application number: **10795071.9**

(86) International application number:
PCT/JP2010/007150

(22) Date of filing: **08.12.2010**

(87) International publication number:
WO 2011/070778 (16.06.2011 Gazette 2011/24)

(54) **IMAGE GENERATING APPARATUS, IMAGE GENERATING METHOD, AND PROGRAM**
BILDERZEUGUNGSVORRICHTUNG, BILDERZEUGUNGSVERFAHREN UND PROGRAMM
APPAREIL DE GÉNÉRATION D'IMAGE, PROCÉDÉ DE GÉNÉRATION D'IMAGE ET PROGRAMME

(84) Designated Contracting States:
AL AT BE BG CH CY CZ DE DK EE ES FI FR GB GR HR HU IE IS IT LI LT LU LV MC MK MT NL NO PL PT RO RS SE SI SK SM TR

• **OISHI, Takuji**
Tokyo (JP)

(30) Priority: **11.12.2009 JP 2009281452**

(74) Representative: **TBK**
Bavariaring 4-6
80336 München (DE)

(43) Date of publication of application:
17.10.2012 Bulletin 2012/42

(56) References cited:
EP-A1- 1 262 148 EP-A1- 1 561 424
JP-A- 2007 301 154 US-A1- 2008 173 093

(73) Proprietor: **Canon Kabushiki Kaisha**
Tokyo 146-8501 (JP)

• **XU MINGHUA ET AL: "Photoacoustic imaging in biomedicine", REVIEW OF SCIENTIFIC INSTRUMENTS, AIP, MELVILLE, NY, US, vol. 77, no. 4, 17 April 2006 (2006-04-17) , pages 041101-1-041101-22, XP012092965, ISSN: 0034-6748, DOI: DOI:10.1063/1.2195024**

(72) Inventors:
• **FUKUTANI, Kazuhiko**
Tokyo (JP)

EP 2 510 382 B1

Note: Within nine months of the publication of the mention of the grant of the European patent in the European Patent Bulletin, any person may give notice to the European Patent Office of opposition to that patent, in accordance with the Implementing Regulations. Notice of opposition shall not be deemed to have been filed until the opposition fee has been paid. (Art. 99(1) European Patent Convention).

Description**Technical Field**

5 **[0001]** The present invention relates to an image generating apparatus, image generating method and program, for generating an image representing information inside a subject.

Background Art

10 **[0002]** Research on imaging apparatuses which irradiate light from a light source (e.g. laser) onto a subject, such as living body, and visualize the information inside the subject, has been energetically progressing in medical fields. An example of such a visualization technology using light is photoacoustic tomography (PAT). A photoacoustic tomography apparatus detects an acoustic wave (typically an ultrasonic wave) generated from a tissue of the living body, which absorbed energy of the light propagating in and diffusing from a subject, at a plurality of locations surrounding the subject.

15 Then the obtained signals are mathematically analyzed, and the information related to the optical property inside the subject, particularly the absorption coefficient distribution, is visualized. Recently pre-clinical research on imaging the blood vessels of small animals using the photoacoustic tomography apparatus, and clinical research on applying the principle of the photoacoustic tomography apparatus to diagnose breast cancer or the like is energetically progressing.

20 **[0003]** In the case of photoacoustic tomography apparatus and ultrasonic diagnostic apparatus (apparatus for detecting acoustic waves reflected in living body and generating an image) which have been conventionally used in medical fields, images are usually generated using an average acoustic velocity of the subject (sound speed of acoustic wave inside the subject, propagation velocity of acoustic wave inside the subject or propagation speed of acoustic wave inside the subject). Generally sound speed is determined based on an experiential value or document-based values. However propagation speeds have individual differences, and sound speed also changes depending on the method of holding a subject, for example. Therefore if the sound speed used for generating an image and the actual sound speed are different, the resolution of an image drops considerably.

25 **[0004]** Patent Literature (PTL) 1, for example, discloses a way to solve this problem. According to the technology disclosed in Patent Literature (PTL) 1, sound speed is determined so that brightness or the contrast of each pixel (or voxel) is maximized. Thereby a drop in image quality, due to a mismatch of the sound speed used for generating the image and the actual sound speed, is suppressed.

30 **[0005]** However in the case of the technology in Patent Literature (PTL) 1, the brightness or contrast of the background noise also increases since the brightness or contrast of each pixel is maximized. Furthermore if noise is included in the detection signals, the sound speed is determined so that the total value of the noise component and normal signal component is maximized, therefore an accurate sound speed cannot be obtained, and the image blurs.

35 **[0006]** (PTL 1) Japanese Patent Application Laid-Open No. 2000-166925

40 **[0007]** Prior art which is related to this field of technology can be found in e.g. non-patent literature Xu Minghua et. al., disclosing photoacoustic imaging in biomedicine, Review of Scientific Instruments, AIP, Melville, NY, US, vol. 77, no. 4, 17 April 2006, pages 041101-1 - 041101-22, in document EP 1 561 424 A1 disclosing non-invasive diagnostic imaging method and apparatus, in document US 2008/173093A1 disclosing system and method for photoacoustic tomography of joints, in document EP 1 262 148 A1 disclosing ultrasonic imaging device, in document EP 1 262 148 A1 disclosing ultrasonic imaging device, and in document JP 2007 301154 A disclosing component concentration measuring instrument.

Summary of Invention

45 **[0008]** The present invention provides an image generating apparatus and an image generating method which can generate an image representing information inside a subject, with suppressing a drop in image quality due to noise and a mismatch of the sound speed used for generating the image and the actual propagation velocity (sound speed).

[0009] The present invention in its first aspect provides an image generating apparatus according to claim 1.

50 **[0010]** The present invention in its second aspect provides an image generating method according to the corresponding independent claim.

[0011] The present invention in its third aspect provides a non-transitory computer readable medium recording a computer program for causing a computer to perform a method according to the second aspect.

55 **[0012]** According to the present invention, an image representing information inside a subject can be generated with suppressing a drop in image quality due to noise and a mismatch of the velocity (sound speed) used for generating the image and the actual propagation velocity (sound speed).

[0013] Further features of the present invention will become apparent from the following description of exemplary embodiments with reference to the attached drawings.

Brief Description of Drawings

[0014]

- 5 [fig. 1] Fig. 1 is a diagram depicting a principle **useful for understanding** the present invention;
 [fig. 2] Fig. 2 is a diagram depicting an example of a configuration of an image generating apparatus according to the present embodiment;
 [fig.3]Fig. 3 is a flow chart depicting a method for generating a generated image;
 10 [fig.4A]Fig. 4A is a diagram depicting an example of the positional relationship of a detection element and a processing target position;
 [fig.4B]Fig. 4B is a graph depicting an example of the directivity of the detection element;
 [fig.5A]Fig. 5A is a diagram depicting an example of simulation conditions according to Example 1;
 [fig.5B]Fig. 5B is a graph depicting an example of a detection signal of the simulation according to Example 1;
 [fig.6]Fig. 6 shows an example of the images generated in simulation according to Example 1;
 15 [fig.7A]Fig. 7A shows an example of the image generated by an image generating apparatus according to Example 2; and
 [fig.7B]Fig. 7B shows an example of the image generated by the image generating apparatus according to Example 2.

Description of Embodiments

20 <Principle>

[0015] The principle **useful for understanding** the present invention will now be described. Fig. 1 is a diagram depicting the principle **useful for understanding** the present invention. In Fig. 1, the reference number 1 indicates a sound source (inside a subject), the reference number 2 indicates a voxel (or a pixel), and the reference number 3 indicates a detection element. Each detection element detects an acoustic wave propagating from the inside of the subject by a time sharing measurement, and outputs a detection signal. A number of the detection elements 3 is N (N is a 2 or higher integer).

[0016] Generally, an image generating apparatus using acoustic waves (ultrasonic waves) generates an image representing information inside a subject using a plurality of detection signals $S(i, t)$ obtained from a plurality of detection elements i . This kind of image is called a "generated image", and is also called "volume data" if the generated image is a three-dimensional image (an aggregate of voxels). A generated image is also called "pixel data" if it is a two-dimensional image. Each pixel (or voxel) of a generated image is normally calculated using a detection signal of which phase is adjusted based on a distance from each detection element to a position corresponding to the pixel and propagation velocity (sound speed) (or propagation velocity (sound speed) of the acoustic wave inside the subject). In the case of a Fourier domain method, however, an image is generated by operation in a frequency space. In Fig. 1, i denotes a number (integer in a 0 to N-1 range) of the detection element, and t denotes time.

[0017] Hereafter the time domain method, which is a general image generation method, will be described in concrete terms. First for each detection element, a distance from the i -th detection element to a position corresponding to a pixel in a generated image is divided by a sound speed. Using this result, time T_i for an acoustic wave reaches the detection element i (delay time) when the acoustic wave generated in this pixel position is calculated (generation time is assumed to be $t = 0$). The intensity $S(i, T_i)$ of the detection signal at time T_i is calculated for each detection element, and the results are added, whereby the pixels of the generated image are generated (the generated image is generated by generating pixels for a plurality of positions in the same manner). According to the technology disclosed in Patent Literature (PTL) 1, the sound speed, that is the time T_i , is determined in this generated image generation method so that the data of each voxel (or pixel) is maximized. The intensity $S(i, T_i)$ indicates the intensity of the detection signal $S(i, t)$ at time T_i (intensity of the detection signal of which phase is adjusted).

[0018] Here if the sound speed estimated as the sound speed and the actual sound speed are significantly different, the intensity $S(i, T_i)$ disperses greatly. To prevent this, according to the **principle**, a target area 5 (area to be targeted) is set in a part of an area inside the subject. Then processing of adjusting the phase of each detection signal $S(i, t)$, based on the distance from each detection element i to the target area 5 and a tentative sound speed, and calculating the dispersion of the intensities $S(i, T_i)$ of a plurality of detection signals of which phases are adjusted, is executed for a plurality of tentative sound speeds. Then a sound speed, out of the plurality of tentative sound speeds, of which the above mentioned dispersion of the intensity $S(i, T_i)$ is minimized, is determined as the sound speed, and the generated image is generated based on this sound speed.

[0019] For example, a coherent factor (CF) given by the following Expression (101) can be used as an index of the dispersion of the delay signal value.

[Math.1]

$$CF = \frac{\left| \sum_{i=0}^{N-1} S(i) \right|^2}{N \sum_{i=0}^{N-1} |S(i)|^2} \quad (101)$$

5

[0020] Here $S(i)$ is an intensity of a detection signal which is output from the detection element i and of which phase is adjusted, that is an intensity $S(i, T_i)$ of the detection signal at time T_i which is calculated based on a sound speed. If $S(i)$ becomes a same value regardless the detection element, the index becomes $CF = 1$, and as the dispersion of the value $S(i)$ increases, the index CF approaches closer to 0. In other words, as the dispersion of the intensity $S(i, T_i)$ is greater, the value of the index CF becomes closer to 0, and as the dispersion is smaller, the value becomes closer to 1. In the present invention, a sound speed at which the dispersion of the intensity $S(i, T_i)$ is minimized, that is a sound speed at which the index CF is the maximized is determined to be the sound speed. The index is not limited to CF . The dispersion may be evaluated with a scale which is used in statistical fields, such as a dispersion value and a standard deviation value.

10

15

[0021] Thus according to the present invention, the sound speed at which the dispersion of the intensity $S(i, T_i)$ is minimized is set to the sound speed, whereby the generated image can be generated based on a sound speed close to the actual sound speed. Also in the present embodiment, an increase in the background noise can be suppressed by limiting the area where the dispersion of the intensity $S(i, T_i)$ is minimum. Further according to the present invention, the sound speed at which the dispersion of the intensity $S(i, T_i)$ is minimized is regarded as the sound speed, so even if noise is randomly included in the detection signal, the noise can be equalized (in other words, the influence of noise can be minimized). As a result, even if noise is included in the detection signal, the actual sound speed can be accurately estimated.

20

[0022] Therefore according to the present invention, an image representing information inside a subject can be generated with suppressing a drop in image quality due to noise and a mismatch of the sound speed used for generating the image and the actual sound speed.

25

<Embodiments>

[0023] Now an image generating apparatus and an image generating method according to the present embodiment will be described. Fig. 2 shows an example of a configuration of an image generating apparatus according to the present embodiment. Here a case of an image generating apparatus (photoacoustic tomography apparatus) using photoacoustic tomography technology, which detects an acoustic wave propagating from the inside of a subject and visualizes biological information, will be described as an example. The present invention can also be applied to an image generating apparatus using ultrasonic diagnostic technology (ultrasonic diagnostic apparatus), which generates an image of information representing the inside of a subject by transmitting an acoustic wave (ultrasonic wave) from an acoustic wave probe and detecting a reflected acoustic wave (ultrasonic wave) which is reflected inside the subject.

35

[0024] The image generating apparatus according to the present embodiment is comprised of a light source 11, an optical apparatus 13, an acoustic wave probe 17, a signal collector 18, an image generation processing unit 19, a signal processor 20 and a display apparatus 21. The light 12 emitted from the light source 11 (intensity modulated light) is irradiated onto a subject 15, such as a living body via the optical apparatus 13. When a part of the energy of the light propagating inside the subject 15 is absorbed by a light absorber (sound source) 14, such as a blood vessel, the acoustic wave (typically an ultrasonic wave) 16 is generated by thermal expansion of the light absorber 14. The generated acoustic wave 16 is detected by the acoustic wave probe 17, and the image of the biological information of the subject is generated by subsequent processing.

45

[0025] The light source 11 emits light having a specific wavelength which is absorbed by a specific component out of the components constituting the living body. The light source 11 may be integrated with the image generating apparatus according to the present embodiment, or may be a separate unit. The light source 11 is constituted by one or more pulsed light sources which can generate pulsed light in a several nano to several hundred nano second order. For the light source, a laser is preferable since a laser exhibits high output, but a light emitting diode or the like may be used instead of a laser. For the laser, various lasers can be used, including a solid-state laser, gas laser, dye laser and semiconductor laser. Irradiation timing, wave form of light, intensity and other factors are controlled by a control unit, which is not illustrated.

50

[0026] The light 12 emitted from the light source 11 is guided to the subject via the optical apparatus 13 (it may also be guided by an optical waveguide or the like). The optical apparatus 13 is, for example, a mirror which reflects light, and a lens which collects or spreads light. For this optical apparatus, any apparatus can be used only if the light 12 emitted from the light source can be irradiated to be a desired shape on the subject 15. Generally it is preferable to spread the light 12 to be a certain area, rather than collecting the light 12 by a lens, in terms of safety of a living body

55

and having a wide diagnosis area. It is preferable that the area on which the light is irradiated on the subject (irradiation area) is movable (changeable). In other words, it is preferable that the image generating apparatus of the present embodiment is constructed such that the light generated from the light source can move on the subject. Then the generated image can be generated over a wider range. It is preferable that the irradiated area (light irradiated on the subject) can move synchronizing with the acoustic wave probe 17. Methods for moving the irradiation area are: using a movable mirror, and mechanically moving the light source itself among others are available.

[0027] The image generating apparatus according to the present embodiment is used for diagnosis of malignant tumors and vascular diseases of humans and animals, for example. Therefore as the subject 15, a diagnosis target area, such as a breast, finger and limb of humans and animals can be assumed. In the photoacoustic tomography apparatus, the light absorber (or sound source) 14 is a portion of the subject where an absorption coefficient is high. For example, in the case when the human body is a measurement target, oxygenated hemoglobin, reduced hemoglobin, blood vessels containing a high amount of these hemoglobins, and a malignant tumor which includes many new blood vessels, for example, could be the light absorbers. In the case of an ultrasonic diagnostic apparatus, the sound source 14 is a tissue interface of which acoustic impedance is different from the surrounding area.

[0028] The acoustic wave probe 17 has a plurality of detection elements. The detection element is constituted by a transducer utilizing piezoelectric phenomena, a transducer utilizing the resonance of light, or a transducer utilizing the change of capacity. Configuration is not limited to this, but can be any configuration that allows acoustic waves to be detected. In the acoustic wave probe 17, a plurality of detection elements are disposed typically in a one-dimensional or two-dimensional arrangement. By using the plurality of detection elements disposed like this, an acoustic wave can be detected in a plurality of locations all at once. Therefore the detection time can be decreased and such an influence as vibration of the subject can be minimized. If the acoustic wave is detected in a plurality of locations by moving the position of one detection element, signals (detection signals) similar to those in the case of using a plurality of detection elements can be obtained.

[0029] The signal collector 18 amplifies an electric signal (analog signal) obtained by the acoustic wave probe 17 (each detection element), and converts it into a digital signal (detection signal). The signal collector 18 is constituted typically by an amplifier, A/D converter and FPGA (Field Programmable Gate Array) chip among other components. It is preferable that a plurality of detection signals can be processed simultaneously. Then the time up to generating an image can be decreased.

[0030] The image generation processing unit 19 generates an image representing information inside the subject (generated image) using a plurality of detection signals (a plurality of digital signals which are output from the signal collector 18) obtained from a plurality of detection elements (the image generating unit). In each case of a general time domain method, each pixel of the generated image is calculated using: a detection signal of which phase is adjusted based on the distance from each detection element to a position corresponding to this pixel; and a sound speed which is determined by the later mentioned signal processor 20.

[0031] The signal processor 20 connected to the image generation processing unit 19 determines the sound speed of the acoustic wave inside the subject (the determination unit). According to the present embodiment, the sound speed is determined using a plurality of digital signals which are output from the signal collector 18 and the image obtained by the image generation processing unit 19.

[0032] The display apparatus 21 is an apparatus for displaying a generated image generated by the image generation processing unit 19. For the display apparatus 21, a liquid crystal display, a plasma display, an organic EL display and a display having electron-emitting devices, for example, can be used.

[0033] Now processing by the image generation processing unit 19 and the signal processor 20 will be described with reference to the flow chart in Fig. 3.

[0034] First the image generation processing unit 19 generates a tentative generated image (volume data) based on the estimated sound speed (predetermined sound speed) of the subject (step 301). For a method to generate a tentative generated image, methods conventionally used for a photoacoustic tomography apparatus and an ultrasonic diagnostic apparatus can be used. For example, a back projection method in a time domain or a Fourier domain can be used.

[0035] In step 301, it is preferable to use an image generating apparatus which generates a generated image by detecting an acoustic wave, such as an ultrasonic diagnostic apparatus and a photoacoustic tomography apparatus. However the present invention is not limited to this, and volume data (a generated image) on biological information may be generated using an image generating apparatus based on a different principle, such as an X-ray CT and MRI.

[0036] Then the signal processor 20 selects a pixel (target pixel) that strongly reflects the biological information out of the volume data (generated image) obtained in step 301, and determines an area which includes the position corresponding to the target pixel as the target area (step 302). In the case of a photoacoustic tomography apparatus, the target pixel is a pixel constituting the absorber, and in the case of an ultrasonic generated image, the target pixel is a pixel in an area where reflection of the ultrasonic wave is high.

[0037] The target pixel may be manually selected by the user checking the generated image, or may be automatically selected. In the case of automatically selecting the target pixel, a pixel of which luminance or contrast is highest in the

image, for example, is selected as the target pixel.

[0038] The size of the target area is determined based on the later mentioned selection range of the tentative sound speed. For example, a case of obtaining a generated image using a 1500 m/sec. sound speed (estimated sound speed c_0 : predetermined sound speed), then switching the sound speed to another sound speed (tentative sound speed) in the 1400 to 1600 m/sec. range and regenerating the image, is considered. Here the pixel pitch d is 0.25 mm, and thickness r of the subject (distance from the position in the subject corresponding to the target pixel to the acoustic wave probe) is 40 mm. In this case, it is possible that the position corresponding to the target pixel shifts about 10 pixels at the maximum in the x , y and z directions. In such a case, an area corresponding to the range including 10 pixels from the target pixel in the x , y and z directions (e.g. range including $21 * 21 * 21$ pixels around the target pixel) is selected as the target area.

[0039] In concrete terms, a position corresponding to the target pixel in the case of using estimated sound speed c_0 (predetermined sound speed) changes for about M pixel in width from this position if the sound speed to be used is changed. The value M is obtained by the following Expression (102). In Expression (102), c_{min} is a minimum value of the tentative sound speed, and c_{max} is a maximum value of the tentative sound speed.

[Math.2]

$$M = \frac{c_0}{d} \left(\frac{r}{c_{min}} - \frac{r}{c_{max}} \right) \quad (102)$$

[0040] Therefore the area corresponding to the range of width M obtained by Expression (102) around the target pixel can be set as the target area. In other words, if a three-dimensional image is generated, an area corresponding to the range which includes $M * M * M$ voxels around the target pixel is selected as the target area. If a two-dimensional image is generated, an area corresponding to the range which includes $M * M$ pixels around the target pixel is selected as the target area. Thereby an area which includes a sound source, such as an absorber, can be the target area.

[0041] The thickness r of the subject in Expression (102) is specifically a distance from a position corresponding to the target pixel to a detection element which is most distant from this position. The thickness of the subject however is not limited to this, but may be a distance from the position corresponding to the target pixel to a detection element which is closest to this position. Or the thickness of the subject may be an average of the distance between the position corresponding to the target pixel and each detection element.

[0042] Then the signal processor 20 adjusts the phase of each detection signal based on the distance from each detection element to the target area (e.g. a position in the target area corresponding to a pixel of the generated image) and a tentative sound speed. Then the signal processor 20 calculates the dispersion of the intensities of a plurality of detection signals of which phases are adjusted (step 303). The processing in step 303 is executed for a plurality of tentative sound speeds.

[0043] Then the signal processor 20 determines a sound speed of which dispersion of intensity is minimized, out of the plurality of tentative sound speeds, as the sound speed (step 304). The image generation processing unit 19 generates the generated image based on the determined sound speed.

[0044] By the above processing, image representing information inside the subject can be generated with suppressing a drop in image quality due to noise and mismatch of the sound speed used for generating the image and actual sound speed.

[0045] If the area of the detection element is large, the detection signal is strongly influenced by the directivity. Directivity will be described with reference to Fig. 4A and Fig. 4B. Directivity is a characteristic where the detection sensitivity of the detection element changes depending on the relative positional relationship between the detection element and a position inside the subject (position corresponding to the pixel: processing target position). For example, if the detection element is facing the processing target position as shown in Fig. 4A, the sensitivity to detect the acoustic wave from this position is at the maximum (intensity of the detection signal is at the maximum). As the deviation between the direction of the detection element and the processing target position becomes greater, the detection sensitivity decreases (intensity of the detection signal decreases). This influence of directivity becomes conspicuous when the width of the element is large, or when the frequency of the acoustic wave to be detected is high. Directivity R (detection sensitivity) is given by the Expression (103).

[Math.3]

$$R = \left| \frac{\sin(k \cdot d \sin\theta)}{k \cdot d \sin\theta} \right| \quad (103)$$

d : width of detection element

θ : angle formed by the line connecting the processing target position and the detection element and the direction of the detection element

k : $2\pi/\lambda$

λ : wavelength of acoustic wave

[0046] The shape of the detection element is assumed to be a square.

[0047] Fig. 4B shows an example of the directivity of the detection element of which the element width is 2 mm. Here a magnitude of each frequency component is calculated using the frequency characteristic obtained from the impulse response of the detection element, and a directivity (detection sensitivity standardized with maximum value 1) is calculated using Expression (103). As Fig. 4B shows, the sensitivity (intensity of detection signal) suddenly drops if the angle formed by the line connecting the processing target position and detection element and the direction of the detection element increases. Such directivity increases dispersion among detection signals.

[0048] Therefore it is preferable that the image generating apparatus of the present embodiment further has a function to correct the drop in intensity of the detection signal due to the directivity of the detection element, according to the relative positional relationship of the position corresponding to the pixel and detection element. And it is preferable that the signal processor 20 determines the sound speed using the detection signal of which intensity is corrected, and the image generation processing unit 19 generates the image using the detection signal, of which intensity is corrected. Thereby the influence of directivity of the detection element can be suppressed. For example, dispersion of the detection signals due to directivity can be decreased (dispersion due to sound speed becomes dominant), so the sound speed can be determined more accurately. Also the dispersion of intensity of the detection signal due to directivity is decreased, so an image of which image quality does not drop can be generated.

[0049] For correction, the angle formed by the line connecting the processing target position and the detection element and the direction of the detection element is calculated based on the relative positional relationship of the processing target position and the detection element, for example, and intensity of the detection signal, which is output from the detection element, is increased based on the value of the directivity according to the angle (e.g. value of the Y axis in Fig. 4B). In concrete terms, the detection signal is multiplied by the inverse number of the value of directivity. Then dispersion of intensity of the detection signal due to directivity can be suppressed.

[0050] In many cases, the processing of the image generation processing unit 19 and the signal processor 20 are implemented by the processing unit of a computer (e.g. workstation) executing software (programs). Therefore the image generation processing unit 19 and the signal processor 20 may not be distinguished. These functional elements may be constructed by a dedicated chip respectively.

[0051] The processing of the image generation processing unit 19 and the signal processor 20 may be implemented by hardware instead of software.

[0052] According to the present embodiment, the target area is determined using the position of the target pixel and Expression (102), but the present invention is not limited to this. If a general location of the target area can be estimated, such as the case when a predetermined subject is measured, information on the target area may be stored in the apparatus in advance. Information on the predetermined target area may be stored in advance for each type (measuring area) of subject. In such a case, the tentative generated image in step 301 of the present embodiment need not be generated. The target area can be any size (even a one pixel size). For example, the target area can be set so that the position corresponding to the target pixel selected in step 302 is included. Since the sound source is assumed to have a certain size, the target area set like this can receive sound from the sound source even if the position corresponding to the target pixel is shifted to outside the target area by a change in sound speed.

<Example 1>

[0053] The present invention is simulated, and the effect thereof is verified. This example will be described with reference to Fig. 5A, Fig. 5B and Fig. 6.

[0054] As a subject, a cubic phantom 43 of which X direction: 4 cm, Y direction: 4 cm and Z direction: 4 cm, is used, as shown in Fig. 5A. At the center of the cubic phantom 43, a cylindrical sound source 41, of which diameter is 0.05 cm and height is 2 cm, is disposed so that the axis direction thereof is parallel with the X direction. Here the sound source 41 is a light absorber in the case of photoacoustic tomography, and an ultrasonic reflector in the case of an ultrasonic diagnostic apparatus. It is assumed that the sound speed of the acoustic wave inside the subject is 1500 m/sec., and the initially generated sound pressure, which is generated in the sound source 41, is 3000 Pa (pascal).

[0055] The acoustic wave probe 42 is a two-dimensional array type and is constituted by 20 * 20 square detection elements. The length of one side of each element is 2 mm, and the pitch distance is 2 mm. It is assumed that the acoustic wave is detected with a sampling frequency of 20 MHz at 1280 measurement points.

[0056] Under the above conditions, the detection signal of the acoustic wave detected by each element of the acoustic wave probe 42 is generated by physical simulation. Fig. 5B shows an example of the detection signal obtained by the detection element at the center of the probe. The strong signal in Fig. 5B indicates a signal from the sound source 41. It is assumed that the detection signal includes a white noise, in which the tripled standard deviation is 20 Pa.

[0057] Using a detection signal obtained in this way and a sound speed (predetermined sound speed) of 1580 m/sec., a generated image is generated. For the generation method, a universal back projection according to a time domain method, which is a publicly known technology, is used. The imaging range is X direction: 3.8 cm, Y direction: 3.8 cm and Z direction: 4 cm, and the pixel pitch (voxel pitch) is 0.025 cm. A total number of voxels is acquired by dividing the imaging range by the voxel pitch, that is 152 * 152 * 160.

[0058] Fig. 6 shows the generated images. All the images shown in Fig. 6 are MIP (Maximum Intensity Projection) images in which maximum intensity of voxel values are projected in the direction of the acoustic wave probe 42, and the white area indicates high sound pressure. The change of sound pressure of the image in the X direction at Y = 2.0 cm is shown above each image.

[0059] In Fig. 6, the image A shows an MIP image of the sound source inside the subject. According to this example, it is assumed that the resolution is higher as the image is closer to image A.

[0060] Image B is a generated image obtained when a 1580 m/sec. sound speed is used as the sound speed. As this image shows, if a sound speed different from the actual sound speed of 1500 m/sec. is used, the image blurs and resolution drops.

[0061] Then in this image (volume data), a voxel of which luminance is maximum is searched. As a result, the voxel at the center (76 * 76 * 80th voxel in all the voxels of 152 * 152 * 160) is detected. The area corresponding to 21 * 21 * 21 voxels centering around this voxel is set as the target area.

[0062] Then in order to compare with prior art, the luminance value is calculated for each position (voxel) in the target area, while changing the sound speed to be used from 1400 m/sec. to 1600 m/sec. at a 2 m/sec. interval. In other words, 21 * 21 * 21 * 101 number of luminance values are calculated. As a result, the sound speed at which the luminance value is maximized is 1456 m/sec. Then using this sound speed 1456 m/ sec., an image is generated again. Image C is an image obtained at this time. The image is somewhat blurred, but resolution is slightly improved compared with image B. The maximum luminance value also increases.

[0063] In order to substantiate the effect of the present invention, the dispersion of intensity (index CF) of the detection signal is calculated for each position (voxel) in the target area while changing the sound speed to be used from 1400 m/sec. to 1600 m/sec. at a 2 m/sec. interval. In other words, 21 * 21 * 21 * 101 number of index CFs are calculated. As a result, the sound speed at which the index CF is maximized is 1492 m/sec. Then using this sound speed of 1492 m/sec., the image is generated again. Image C' is an image obtained at this time. Compared with image C, which is the prior art, image blur is less and resolution improves.

[0064] Table 1 shows this result.

[Table 1]

	Velocity	Image quality (amount of blur)
Image A (actual image)	1500 m/sec.	None
Image B (estimate)	1580 m/sec.	High
Image C (prior art)	1456 m/sec.	Mid-
Image C' (this example)	1492 m/sec.	Low

[0065] In this way, according to the present invention, a sound speed close to the actual sound speed (1492 m/sec.) can be estimated. Particularly in a detection signal containing noise, a sound speed closer to the actual sound speed can be estimated than the sound speed obtained by the prior art (1456 m/sec.). As a result, an image without a drop in resolution can be obtained.

[0066] The sound speed is estimated as 1492 m/sec. while the actual sound speed is 1500 m/ sec., because of the influence of noise and directivity of the detection element.

[0067] In this example, dispersion of the intensity of the detection signals is calculated for each position in the target area, but the dispersion may be calculated for a part of the positions in the target area. For example, the dispersion may be calculated only for the center position of the target area.

<Example 2>

[0068] An example of applying the present invention to a photoacoustic tomography apparatus will now be described

with reference to Fig. 2. In this example, a Q switch YAG laser, which generates a pulsed light with a 1064 nm wavelength for about 10 nano seconds, is used as a light source 11. The energy of the pulsed laser beam (light 12) is 0.6 J, and this pulsed light spreads to about a 2 cm radius using an optical apparatus 13 such as a mirror and a beam expander. For a subject 15, a phantom simulating a living body is used. The phantom used is 1% intralipid solidified with agar. The size of the phantom is width: 12 cm, height: 8 cm and depth: 4 cm. In this phantom, a black rubber wire with a 0.03 cm diameter is embedded as a light absorber 14 in the center area. Light 12, which is spread to a 2 cm radius, is irradiated onto this phantom. For the acoustic wave probe 17, an ultrasonic transducer made from PZT (lead zirconate titanate) is used. This transducer is a two-dimensional array type, where a number of elements is $18 * 18$, the shape of each element is square, and the element pitch is 2 mm. The width of each element is about 2 mm. This acoustic wave probe can move in the X and Y directions synchronizing with the light irradiation area, so as to image a large area.

[0069] If a pulsed light is irradiated onto one surface of the phantom, the light diffused inside the phantom is absorbed by the rubber wire, and a photoacoustic wave is generated. This photoacoustic wave is detected by each ultrasonic transducer having 324 channels, and the digital data (detection signal) of the photoacoustic wave is obtained for each channel, using a signal collector 18, which is comprised of an amplifier, A/D converter and FPGA. In order to improve the S/N ratio of the signal, the laser is irradiated 36 times, and all obtained detection signals are averaged. Then the obtained digital data is transferred to a workstation (WS), which is an image generation processor 19 and a signal processor 20, and the WS stores this data. After performing noise reduction processing on this stored data by discrete wavelet transformation, the image is generated using a 1540 m/sec. sound speed, which is an average sound speed of an acoustic wave inside living body. Here volume data is generated using a universal back projection method, which is a time domain method. The voxel pitch used in this case is 0.05 cm. The imaging range is set to 11.8 cm * 11.8 cm * 4.0 cm. Fig. 7A shows an example of the obtained image.

[0070] Then the dispersion of intensity (index CF) of the detection signal is calculated for each position (voxel) in the target area, while changing the sound speed to be used from 1400 m/sec. to 1600 m/sec. at a 2 m/sec. interval. According to this example, in the obtained volume data, an area corresponding to the voxel group ($21 * 21 * 21$ voxels), which includes the sound wave (initial sound pressure) generated in the wire, is set as the target area. Also according to this example, the detection signal is corrected considering the directivity calculated based on the impulse response of the detection element, and the index CF is calculated using the corrected detection signal. The maximum index CF improved from 0.056 to 0.078 by considering the directivity. In this example, the sound speed at which the index CF becomes maximum is 1454 m/ sec. Then using this 1454 m/sec. sound speed and the detection signal stored in a PC, an image is generated again. The obtained image is displayed on a liquid crystal display, which is a display apparatus 21. Fig. 7B shows an example of the obtained image.

[0071] As the above result shows, the width of the acoustic wave (initial sound pressure) generated from the rubber wire is obviously narrower in the image generated using a 1454 m/sec. sound speed (Fig. 7B) than in the image generated using a 1540 m/sec. sound speed (Fig. 7A). It is clear that there is hardly any image blur, in other words, resolution improved.

[0072] In this way, according to this example, the sound speed of the acoustic wave inside the subject can be accurately estimated, and therefore resolution of the generated image can be improved.

[0073] Aspects of the present invention can also be realized by a computer of a system or apparatus (or devices such as a CPU or MPU) that reads out and executes a program recorded on a memory device to perform the functions of the above-described embodiment(s), and by a method, the steps of which are performed by a computer of a system or apparatus by, for example, reading out and executing a program recorded on a memory device to perform the functions of the above-described embodiment(s). For this purpose, the program is provided to the computer for example via a network or from a recording medium of various types serving as the memory device (e.g., non-transitory computer-readable medium).

[0074] While the present invention has been described with reference to exemplary embodiments, it is to be understood that the invention is not limited to the disclosed exemplary embodiments but by the scope of the following claims.

Claims

1. An image generating apparatus, comprising:

a light source adapted to irradiate a pulsed light onto a subject to generate an acoustic wave
 a probe (17) having a plurality of detection elements adapted to detect the acoustic wave (16) which is generated by irradiation of the pulsed light and propagates from inside the subject (15) and to output a plurality of detection signals corresponding to the plurality of detection elements;
 a determination unit (20) adapted to determine a first propagation velocity of the acoustic wave;
 an image generating unit (19) adapted to obtain a first image representing information inside the subject (15)

using the first propagation velocity determined by the determination unit (20) and the plurality of detection signals, wherein the determination unit (20) is adapted to:

5 set a target position inside the subject (15),
 set a second propagation velocity,
 determine a detection signal, corresponding to the target position, from among each of the plurality of
 detection signals on the basis of a distance from each of the plurality of detection elements to the target
 10 position and the second propagation velocity,
 obtain information which represents dispersion of the plurality of detection signals corresponding to the
 target position, and
 determine the first propagation velocity based on the information which represents the dispersion of the
 plurality of detection signals corresponding to the target position,
 15 wherein the image generating unit (19) is adapted to obtain a data of a pixel or a voxel included in the first
 image using a detection signal corresponding to the target position based on a distance from each of the
 plurality of detection elements to a position corresponding to the pixel or the voxel and the first propagation
 velocity determined by the determination unit (20).

20 2. The image generating apparatus according to Claim 1, wherein
 the determination unit (20) is adapted to set the target position using a second image generated based on a third
 propagation velocity and the plurality of detection signals.

25 3. The image generating apparatus according to Claim 1, wherein
 the determination unit (20) is adapted to set the target position using a second image generated by an image
 generating apparatus.

30 4. The image generating apparatus according to Claim 1, wherein
 the determination unit (20) is adapted to set the target position using a second image generated by an X-ray CT,
 MRI, or an ultrasonic diagnostic apparatus.

35 5. The image generating apparatus according to Claim 1, wherein
 the determination unit (20) is adapted to set the target position using a second image generated based on ultrasonic
 diagnostic technology.

40 6. The image generating apparatus according to any one of Claim 1 to Claim 5, wherein
 the determination unit (20) is adapted to set a position of a blood vessel using the second image, as the target position.

45 7. The image generating apparatus according to any one of Claim 2 to Claim 5 wherein
 the determination unit (20) is adapted to set the target position based on information indicating a selection by an
 user for the second image data.

50 8. The image generating apparatus according to any one of Claim 1 to Claim 7, wherein
 the determination unit is adapted to execute processing to adjust a phase of each of the detection signals based
 on a distance from each of the plurality of detection elements to the target position and the second propagation
 velocity, and to obtain the information which represents dispersion of the plurality of detection signals of which
 phases are adjusted, for a plurality of second propagation velocities, and
 to determine a second velocity for which dispersion of the plurality of detection signals of which phases are
 adjusted is minimized, out of the plurality of second velocities, as the first propagation velocity.

55 9. The image generating apparatus according to any one of Claim 2 to Claim 7, wherein
 the determination unit is adapted to set a target pixel or a target voxel having the highest luminance value or contrast,
 using the second image.

 10. The image generating apparatus according to any one of Claim 2 to Claim 7, wherein
 the determination unit is adapted to set a target pixel or a target voxel having the highest luminance value or
 contrast, using the second image,

to set an area which is around the target pixel or the target voxel and corresponds to a range of pixels or voxels having width M given by the following expression as a target area,

[Math. 2]

$$M = \frac{c_0}{d} \left(\frac{r}{c_{\min}} - \frac{r}{c_{\max}} \right)$$

where c_{\min} is a minimum value and c_{\max} is a maximum value out of the plurality of second propagation velocities, d is a pixel pitch, r is a distance from the probe to the position corresponding to the target pixel, and c_0 is the predetermined propagation velocity.

11. The image generating apparatus according to any one of Claim 1 to Claim 10, further comprising

a correction unit adapted to correct a drop in the detection signal due to directivity of the detection element according to a relative positional relationship between a position corresponding to a pixel and the detection element, wherein the determination unit is adapted to determine the first propagation velocity using the detection signal which is corrected.

12. The image generating apparatus according to any one of Claim 1 to Claim 10, wherein the determination unit is adapted to determine the first propagation velocity of which index CF, as the information which represents the dispersion of the plurality of detection signals corresponding to the target position, represented by the following expression is maximized,

[Math. 1]

$$CF = \frac{\left| \sum_{i=0}^{N-1} S(i) \right|^2}{N \sum_{i=0}^{N-1} |S(i)|^2}$$

where N (N is an integer that is 2 or greater) is the number of the detection elements, and $S(i)$ (i is an integer in a range from 0 to $N-1$) is a detection signal which is output from the i -th detection element and corresponds to the target position.

13. An image generating method, comprising:

a step of irradiating a pulsed light onto a subject to generate an acoustic wave,
 a step of detecting the acoustic wave which is generated by irradiation of the pulsed light and propagates from inside the subject using a plurality of detection elements and outputting a plurality of detection signals corresponding to the plurality of detection elements;
 a determination step of determining a first propagation velocity of the acoustic wave; and
 an image generating step of generating a first image representing information inside the subject using the first propagation velocity determined in the determination step and the plurality of detection signals, wherein
 in the determination step,
 a target position is set inside the subject,
 a second propagation velocity is set,
 a detection signal corresponding to the target position is determined from among each of the plurality of detection signals on the basis of a distance from each of the plurality of detection elements to the target position and the second propagation velocity,
 information which represents dispersion of the plurality of detection signals corresponding to the target position, and
 the first propagation velocity is determined based on the information which represents the dispersion the plurality of detection signals corresponding to the target position,
 wherein, in the image generating step, a data of a pixel or a voxel included in the first image is obtained, using

a detection signal corresponding to the target position based on a distance from each of the plurality of detection elements to a position corresponding to the pixel or the voxel and the first propagation velocity determined in the determination step.

5 14. The image generating method according Claim 13, wherein

in the determination step,
processing to adjust a phase of each of the detection signals based on a distance from each of the plurality of
detection elements to the target position and the second propagation velocity, and obtain the information which
10 represents dispersion of the plurality of detection signals of which phases are adjusted, is executed for a plurality
of second velocities, and
a second propagation velocity for which dispersion of the plurality of detection signals of which phases are
adjusted is minimized, out of the plurality of second velocities, is determined as the first propagation velocity.

15 15. A non-transitory computer readable medium recording a computer program for causing a computer to perform the
image generating method according to Claim 13 or Claim 14.

Patentansprüche

- 20
1. Bilderzeugungsvorrichtung mit:
- einer Lichtquelle, die angepasst ist, ein gepulstes Licht auf ein Subjekt zu bestrahlen, um eine akustische Welle
zu erzeugen;
25 einem Prüfkopf (17) mit einer Vielzahl von Erfassungselementen, die angepasst sind, die akustische Welle (16)
zu erfassen, die durch Bestrahlung mit dem gepulsten Licht erzeugt wurde und die vom Inneren des Subjekts
(15) propagiert, und um eine Vielzahl von Erfassungssignalen entsprechend der Vielzahl der Erfassungsele-
mente auszugeben;
einer Bestimmungseinheit (20), die angepasst ist, eine erste Propagationsgeschwindigkeit der akustischen
30 Welle zu bestimmen;
einer Bilderzeugungseinheit (19), die angepasst ist, ein erstes Bild, das eine Information innerhalb des Subjekts
(15) repräsentiert, unter Verwendung der ersten Propagationsgeschwindigkeit, die durch die Bestimmungsein-
heit (20) bestimmt wird, und der Vielzahl der Erfassungssignale zu erhalten, wobei
die Bestimmungseinheit (20) angepasst ist, um:
- 35 eine Zielposition innerhalb des Subjekts (15) einzustellen,
eine zweite Propagationsgeschwindigkeit einzustellen,
ein Erfassungssignal entsprechend der Zielposition von jedem der Vielzahl der Erfassungssignale auf der
Basis eines Abstands von jedem der Vielzahl der Erfassungselemente zu der Zielposition und der zweiten
40 Propagationsgeschwindigkeit anzupassen,
eine Information zu erhalten, die eine Dispersion der Vielzahl der Erfassungssignale entsprechend der
Zielposition repräsentiert, und
die erste Propagationsgeschwindigkeit basierend auf der Information, die die Dispersion der Vielzahl der
Erfassungssignale entsprechend der Zielposition repräsentiert, zu bestimmen, wobei
45 die Bilderzeugungseinheit (19) angepasst ist, Daten eines Pixels oder eines Voxels, das in dem ersten Bild
enthalten ist, unter Verwendung eines Erfassungssignals entsprechend der Zielposition basierend auf ein-
nem Abstand von jedem der Vielzahl der Erfassungselemente zu einer Position, die dem Pixel oder Voxel
entspricht, und der ersten Propagationsgeschwindigkeit, die durch die Bestimmungseinheit (20) bestimmt
wird zu erhalten.
- 50
2. Bilderzeugungsvorrichtung nach Anspruch 1, wobei
die Bestimmungseinheit (20) angepasst ist, die Zielposition unter Verwendung eines zweiten Bildes, das basierend
auf einer dritten Propagationsgeschwindigkeit und der Vielzahl der Erfassungssignale erzeugt wird, einzustellen.
- 55
3. Bilderzeugungsvorrichtung nach Anspruch 1, wobei
die Bestimmungseinheit (20) angepasst ist, die Zielposition unter Verwendung eines zweiten Bildes, das durch die
Bilderzeugungsvorrichtung erzeugt wird, einzustellen.

EP 2 510 382 B1

4. Bilderzeugungsvorrichtung nach Anspruch 1, wobei die Bestimmungseinheit (20) angepasst ist, die Zielposition unter Verwendung eines zweiten Bildes, das durch ein Röntgen-CT, MRI, oder eine Ultraschalldiagnosevorrichtung erzeugt wird, einzustellen.
- 5 5. Bilderzeugungsvorrichtung nach Anspruch 1, wobei die Bestimmungseinheit (20) angepasst ist, die Zielposition unter Verwendung eines zweiten Bildes, das basierend auf einer Ultraschalldiagnosetechnologie erzeugt wird, einzustellen.
- 10 6. Bilderzeugungsvorrichtung nach einem der Ansprüche 1 bis 5, wobei die Bestimmungseinheit (20) angepasst ist, eine Position eines Blutgefäßes unter Verwendung des zweiten Bildes als die Zielposition einzustellen.
- 15 7. Bilderzeugungsvorrichtung nach einem der Ansprüche 2 bis 5, wobei die Bestimmungseinheit (20) angepasst ist, die Zielposition basierend auf einer Information, die eine Auswahl durch einen Nutzer für die zweiten Bilddaten angibt, einzustellen.
- 20 8. Bilderzeugungsvorrichtung nach einem der Ansprüche 1 bis 7, wobei die Bestimmungseinheit angepasst ist, ein Verarbeiten durchzuführen, um eine Phase von jedem der Erfassungssignale basierend auf einem Abstand von jedem der Vielzahl der Erfassungselemente zu der Zielposition und der zweiten Propagationsgeschwindigkeit anzupassen und die Information, die eine Dispersion der Vielzahl der Erfassungssignale, deren Phasen angepasst sind, für eine Vielzahl von zweiten Propagationsgeschwindigkeit zu erhalten, und eine zweite Geschwindigkeit, für die die Dispersion der Vielzahl der Erfassungssignale, deren Phasen angepasst sind, minimiert ist, aus der Vielzahl der zweiten Geschwindigkeiten als die erste Propagationsgeschwindigkeit zu bestimmen.
- 25 9. Bilderzeugungsvorrichtung nach einem der Ansprüche 2 bis 7, wobei die Bestimmungseinheit angepasst ist, ein Zielpixel oder ein Zielvoxel mit dem höchsten Luminanzwert oder Kontrast unter Verwendung des zweiten Bildes einzustellen.
- 30 10. Bilderzeugungsvorrichtung nach einem der Ansprüche 2 bis 7, wobei die Bestimmungseinheit angepasst ist, ein Zielpixel oder ein Zielvoxel mit dem höchsten Luminanzwert oder Kontrast unter Verwendung des zweiten Bildes einzustellen, ein Gebiet, das um das Zielpixel oder das Zielvoxel liegt und einem Bereich von Pixeln oder Voxeln entspricht, der eine Breite M hat, die durch den folgenden Ausdruck gegeben ist, als ein Zielgebiet einzustellen:

[Math. 2]

$$M = \frac{c_0}{d} \left(\frac{r}{c_{\min}} - \frac{r}{c_{\max}} \right)$$

- 35 40 45 wobei c_{\min} ein Minimalwert und c_{\max} ein Maximalwert aus der Vielzahl der zweiten Propagationsgeschwindigkeiten ist, d ein Pixelabstand ist, r ein Abstand von der Probe zu der Position, die dem Zielpixel entspricht, ist, und c_0 die vorbestimmte Propagationsgeschwindigkeit ist.

- 50 55 11. Bilderzeugungsvorrichtung nach einem der Ansprüche 1 bis 10, ferner mit einer Korrekturereinheit, die angepasst ist, ein Abnehmen des Erfassungssignals aufgrund einer Direktivität des Erfassungselements gemäß einer relativen Positionsbeziehung zwischen einer Position, die einem Pixel entspricht, und dem Erfassungselement zu korrigieren, wobei die Bestimmungseinheit angepasst ist, die erste Propagationsgeschwindigkeit unter Verwendung des Erfassungssignals zu bestimmen, das korrigiert ist.
12. Bilderzeugungsvorrichtung nach einem der Ansprüche 1 bis 10, wobei die Bestimmungseinheit angepasst ist, die erste Propagationsgeschwindigkeit, deren Index CF als die Information, die die Dispersion der Vielzahl der Erfassungssignale entsprechend der Zielposition repräsentiert, maximiert wird,

zu bestimmen, wobei der Index CF durch den folgenden Ausdruck repräsentiert wird:

[Math. 1]

$$CF = \frac{\left| \sum_{i=0}^{N-1} S(i) \right|^2}{N \sum_{i=0}^{N-1} |S(i)|^2}$$

wobei N (N ist eine ganze Zahl, die 2 oder größer ist) die Anzahl der Erfassungselemente ist, und S (i) (i ist eine ganze Zahl in einem Bereich von 0 bis N-1) ein Erfassungssignal ist, das von dem i-ten Erfassungselement ausgehen wird und der Zielposition entspricht.

13. Bilderzeugungsverfahren mit:

einem Schritt des Bestrahlers eines gepulsten Lichts auf ein Subjekt, um eine akustische Welle zu erzeugen; einem Schritt des Erfassens der akustischen Welle, die durch die Bestrahlung mit dem gepulsten Licht erzeugt wird und die aus dem Inneren des Subjekts propagiert, unter Verwendung einer Vielzahl von Erfassungselementen und eines Ausgebens einer Vielzahl von Erfassungssignalen entsprechend der Vielzahl der Erfassungselemente;

einem Bestimmungsschritt des Bestimmens einer ersten Propagationsgeschwindigkeit der akustischen Welle; und

einem Bilderzeugungsschritt des Erzeugens eines ersten Bildes, das eine Information des Inneren des Subjekts repräsentiert, unter Verwendung der ersten Propagationsgeschwindigkeit, die in dem Bestimmungsschritt bestimmt wird, und der Vielzahl der Erfassungssignale wobei in dem Bestimmungsschritt:

eine Zielposition innerhalb des Subjekts eingestellt wird, eine zweite Propagationsgeschwindigkeit eingestellt wird, ein Erfassungssignal entsprechend der Zielposition von jedem der Vielzahl der Erfassungssignale auf der Basis eines Abstands von jedem der Vielzahl der Erfassungselemente zu der Zielposition und der zweiten Propagationsgeschwindigkeit bestimmt wird, eine Information, die eine Dispersion der Vielzahl der Erfassungssignale entsprechend der Zielposition repräsentiert, erhalten wird, und die erste Propagationsgeschwindigkeit basierend auf der Information, die die Dispersion der Vielzahl der Erfassungssignale entsprechend der Zielposition repräsentiert, bestimmt wird, wobei in dem Bilderzeugungsschritt Daten eines Pixels oder eines Voxels, das in dem ersten Bild enthalten ist, unter Verwendung eines Erfassungssignals entsprechend der Zielposition basierend auf einem Abstand von jedem der Vielzahl der Erfassungselemente zu einer Position, die dem Pixel oder dem Voxel entspricht, und der ersten Propagationsgeschwindigkeit, die in dem Bestimmungsschritt bestimmt wird, erhalten werden.

14. Bilderzeugungsvorrichtung nach Anspruch 13, wobei

in dem Bestimmungsschritt

ein Verarbeiten zum Anpassen einer Phase von jedem der Erfassungssignale basierend auf einem Abstand von jedem der Vielzahl der Erfassungselemente zu der Zielposition und der zweiten Propagationsgeschwindigkeit und zum Erhalten der Information, die eine Dispersion der Vielzahl der Erfassungssignale, deren Phasen angepasst sind, für eine Vielzahl von zweiten Geschwindigkeiten durchgeführt wird, und

eine zweite Propagationsgeschwindigkeit, für die eine Dispersion der Vielzahl der Erfassungssignale, deren Phasen angepasst sind, minimiert ist, aus der Vielzahl der zweiten Geschwindigkeiten als die erste Propagationsgeschwindigkeit bestimmt wird.

15. Nichtflüchtiges computerlesbares Medium, das ein Computerprogramm zum Verursachen, dass ein Computer das Bilderzeugungsverfahren nach Anspruch 13 oder Anspruch 14 durchführt, aufzeichnet.

Revendications

1. Appareil générateur d'image, comprenant :

5 une source de lumière conçue pour soumettre un sujet à une lumière pulsée de façon à générer une onde acoustique ;
 une sonde (17) comportant plusieurs éléments de détection, conçue pour détecter l'onde acoustique (16) qui est générée par le rayonnement de la lumière pulsée et qui se propage à partir de l'intérieur du sujet (15) et pour délivrer en sortie une pluralité de signaux de détection correspondant à la pluralité d'éléments de détection ;
 10 une unité de détermination (20) conçue pour déterminer une première vitesse de propagation de l'onde acoustique ;
 une unité génératrice d'image (19) conçue pour obtenir une première image représentant des informations à l'intérieur du sujet (15) au moyen de la première vitesse de propagation déterminée par l'unité de détermination (20) et de la pluralité de signaux de détection, dans lequel
 15 l'unité de détermination (20) est conçue pour :

définir une position cible à l'intérieur du sujet (15),
 définir une deuxième vitesse de propagation,
 déterminer un signal de détection, correspondant à la position cible, parmi chaque signal de la pluralité de signaux de détection sur la base d'une distance de chacun des plusieurs éléments de détection à la position cible et de la deuxième vitesse de propagation,
 20 obtenir des informations qui représentent une dispersion de la pluralité de signaux de détection correspondant à la position cible, et
 déterminer la première vitesse de propagation sur la base des informations qui représentent la dispersion de la pluralité de signaux de détection correspondant à la position cible,
 25 dans lequel l'unité génératrice d'image (19) est conçue pour obtenir une donnée d'un pixel ou d'un voxel compris dans la première image au moyen d'un signal de détection correspondant à la position cible sur la base d'une distance de chacun des plusieurs éléments de détection à une position correspondant au pixel ou au voxel et de la première vitesse de propagation déterminée par l'unité de détermination (20).

2. Appareil générateur d'image selon la revendication 1, dans lequel :

l'unité de détermination (20) est conçue pour définir la position cible au moyen d'une seconde image générée sur la base d'une troisième vitesse de propagation et de la pluralité de signaux de détection.

3. Appareil générateur d'image selon la revendication 1, dans lequel :

l'unité de détermination (20) est conçue pour définir la position cible au moyen d'une seconde image générée par un appareil générateur d'image.

4. Appareil générateur d'image selon la revendication 1, dans lequel :

l'unité de détermination (20) est conçue pour définir la position cible au moyen d'une seconde image générée par tomographie assistée par ordinateur aux rayons X, par IRM ou par un appareil de diagnostic par ultrasons.

5. Appareil générateur d'image selon la revendication 1, dans lequel :

l'unité de détermination (20) est conçue pour définir la position cible au moyen d'une seconde image générée sur la base d'une technologie de diagnostic par ultrasons.

6. Appareil générateur d'image selon l'une quelconque des revendications 1 à 5, dans lequel :

l'unité de détermination (20) est conçue pour définir une position d'un vaisseau sanguin, en tant que position cible, au moyen de la seconde image.

7. Appareil générateur d'image selon l'une quelconque des revendications 2 à 5, dans lequel :

l'unité de détermination (20) est conçue pour définir la position cible sur la base d'informations indiquant une

EP 2 510 382 B1

sélection d'un utilisateur des données de seconde d'image.

8. Appareil générateur d'image selon l'une quelconque des revendications 1 à 7, dans lequel :

5 l'unité de détermination est conçue pour exécuter un traitement ayant pour objet d'ajuster une phase de chacun des signaux de détection sur la base d'une distance de chacun des plusieurs éléments de détection à la position cible et de la deuxième vitesse de propagation, et pour obtenir les informations qui représentent une dispersion de la pluralité de signaux de détection dont les phases ont fait l'objet d'un ajustement, par rapport à une pluralité de deuxièmes vitesses de propagation, et
10 pour déterminer une deuxième vitesse pour laquelle la dispersion de la pluralité de signaux de détection dont les phases ont fait l'objet d'un ajustement a été réduite au minimum, parmi la pluralité de deuxièmes vitesses, en tant que première vitesse de propagation.

9. Appareil générateur d'image selon l'une quelconque des revendications 2 à 7, dans lequel :

15 l'unité de détermination est conçue pour définir un pixel cible ou un voxel cible dont la valeur de luminance ou le contraste est le plus élevé, au moyen de la seconde image.

10. Appareil générateur d'image selon l'une quelconque des revendications 2 à 7, dans lequel :

20 l'unité de détermination est conçue pour définir un pixel cible ou un voxel cible dont la valeur de luminance ou le contraste est le plus élevé, au moyen de la seconde image, de façon à définir une zone entourant le pixel cible ou le voxel cible et correspondant à une étendue de pixels ou de voxels dont la largeur M est donnée par l'expression suivante en tant qu'étendue cible,

25

$$[\text{Math. 2}]$$
$$M = \frac{c_0}{d} \left(\frac{r}{c_{\min}} - \frac{r}{c_{\max}} \right)$$

30

où c_{\min} est une valeur minimale et c_{\max} est une valeur maximale parmi la pluralité de deuxièmes vitesses de propagation, d est un pas entre pixels, r est une distance de la sonde à la position correspondant au pixel cible, et c_0 est la vitesse de propagation prédéterminée.

- 35 11. Appareil générateur d'image selon l'une quelconque des revendications 1 à 10, comprenant en outre :

une unité de correction conçue pour corriger une chute de l'intensité du signal de détection due à une directivité de l'élément de détection conformément à une relation de position relative entre une position correspondant à un pixel et l'élément de détection,
40 l'unité de détermination étant conçue pour déterminer la première vitesse de propagation au moyen du signal de détection qui a été corrigé.

- 45 12. Appareil générateur d'image selon l'une quelconque des revendications 1 à 10, dans lequel :

l'unité de détermination est conçue pour déterminer la première vitesse de propagation dont l'indice CF, en tant qu'informations représentant la dispersion de la pluralité de signaux de détection correspondant à la position cible, représenté par l'expression suivante, est amené à une valeur maximale,

50

$$[\text{Math. 1}]$$
$$CF = \frac{\left| \sum_{i=0}^{N-1} S(i) \right|^2}{N \sum_{i=0}^{N-1} |S(i)|^2}$$

55

où N (N étant un nombre entier supérieur ou égal à 2) est le nombre d'éléments de détection, et S(i) (i étant un

nombre entier s'inscrivant dans une plage de 0 à N-1) est un signal de détection qui est délivré par le ^{ième} élément de détection et qui correspond à la position cible.

5
10
15
20
25
30

13. Procédé de génération d'image, comprenant :

une étape consistant à soumettre un sujet à une lumière pulsée de façon à générer une onde acoustique,
une étape consistant à détecter l'onde acoustique qui a été générée par le rayonnement de la lumière pulsée
et qui se propage à partir de l'intérieur du sujet au moyen de plusieurs éléments de détection, et à délivrer en
sortie une pluralité de signaux de détection correspondant aux plusieurs éléments de détection ;
une étape de détermination consistant à déterminer une première vitesse de propagation de l'onde acoustique ;
et
une étape de génération d'image consistant à générer une première image représentant des informations à
l'intérieur du sujet au moyen de la première vitesse de propagation déterminée lors de l'étape de détermination
et de la pluralité de signaux de détection, dans lequel :

lors de l'étape de détermination,
une position cible est définie à l'intérieur du sujet,
une deuxième vitesse de propagation est définie,
un signal de détection correspondant à la position cible est déterminé à partir de chaque signal de la pluralité
de signaux de détection sur la base d'une distance de chacun des plusieurs éléments de détection à la
position cible et de la deuxième vitesse de propagation,
des informations qui représentent une dispersion de la pluralité de signaux de détection correspondant à
la position cible sont obtenues, et
la première vitesse de propagation est déterminée sur la base des informations qui représentent la dispersion
de la pluralité de signaux de détection correspondant à la position cible,
dans lequel, lors de l'étape de génération d'image, une donnée d'un pixel ou d'un voxel compris dans la
première image est obtenue, au moyen d'un signal de détection correspondant à la position cible sur la
base d'une distance de chacun des plusieurs éléments de détection à une position correspondant au pixel
ou au voxel et de la première vitesse de propagation déterminée lors de l'étape de détermination.

35
40
45
50
55

14. Procédé de génération d'image selon la revendication 13, dans lequel :

lors de l'étape de détermination,
un traitement consistant à ajuster une phase de chacun des signaux de détection sur la base d'une distance
de chacun des plusieurs éléments de détection à la position cible et de la deuxième vitesse de propagation, et
à obtenir les informations qui représentent une dispersion de la pluralité de signaux de détection dont les phases
ont fait l'objet d'un ajustement, est exécuté par rapport à une pluralité de deuxièmes vitesses, et
une deuxième vitesse de propagation pour laquelle une dispersion de la pluralité de signaux de détection dont
les phases ont fait l'objet d'un ajustement a été réduite au minimum, parmi la pluralité de deuxièmes vitesses,
est déterminée en tant que première vitesse de propagation.

15. Support non transitoire lisible par ordinateur contenant en mémoire un programme d'ordinateur destiné à amener
un ordinateur à mettre en oeuvre le procédé de génération d'image selon la revendication 13 ou la revendication 14.

[Fig. 1]

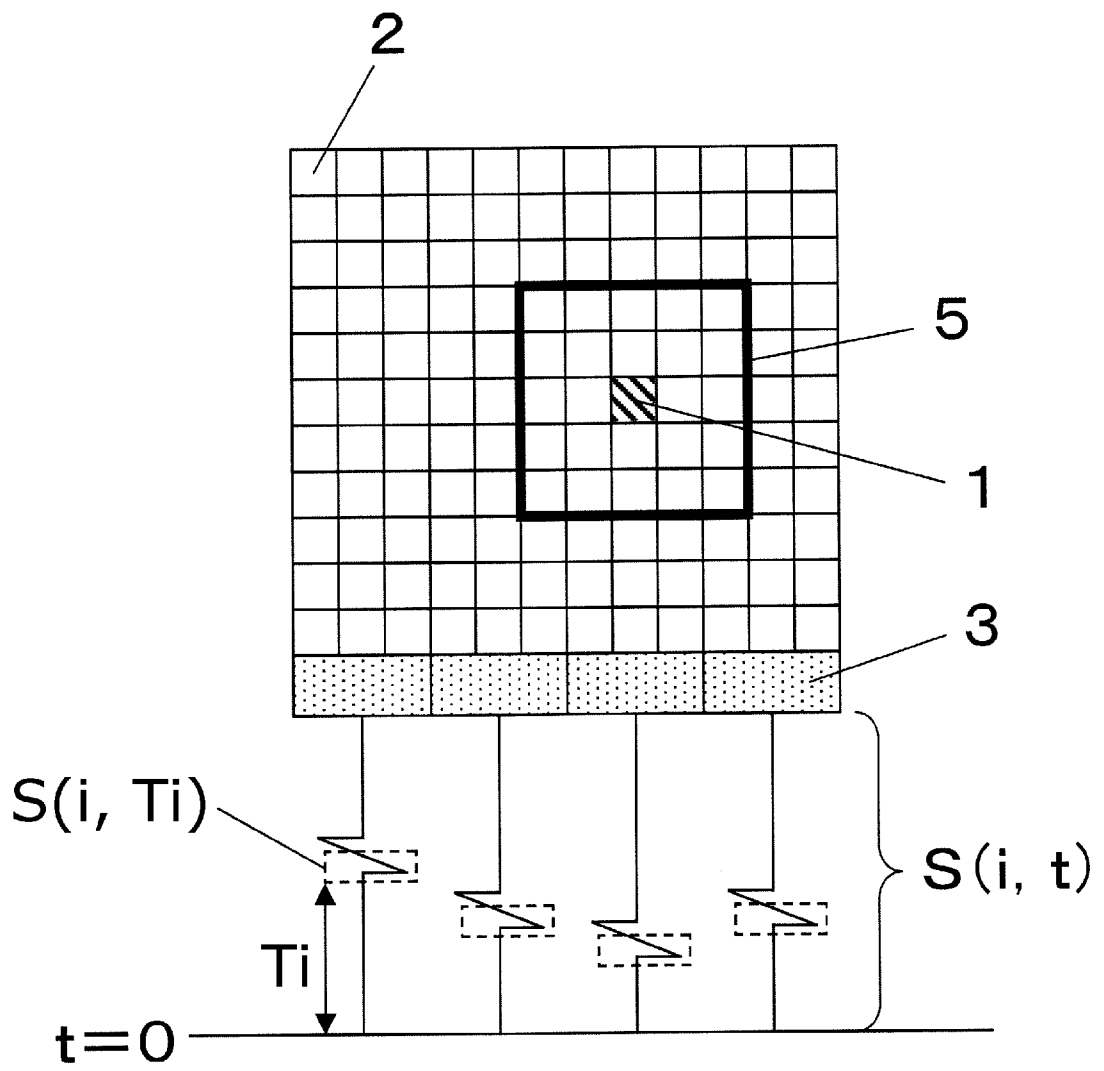

[Fig. 2]

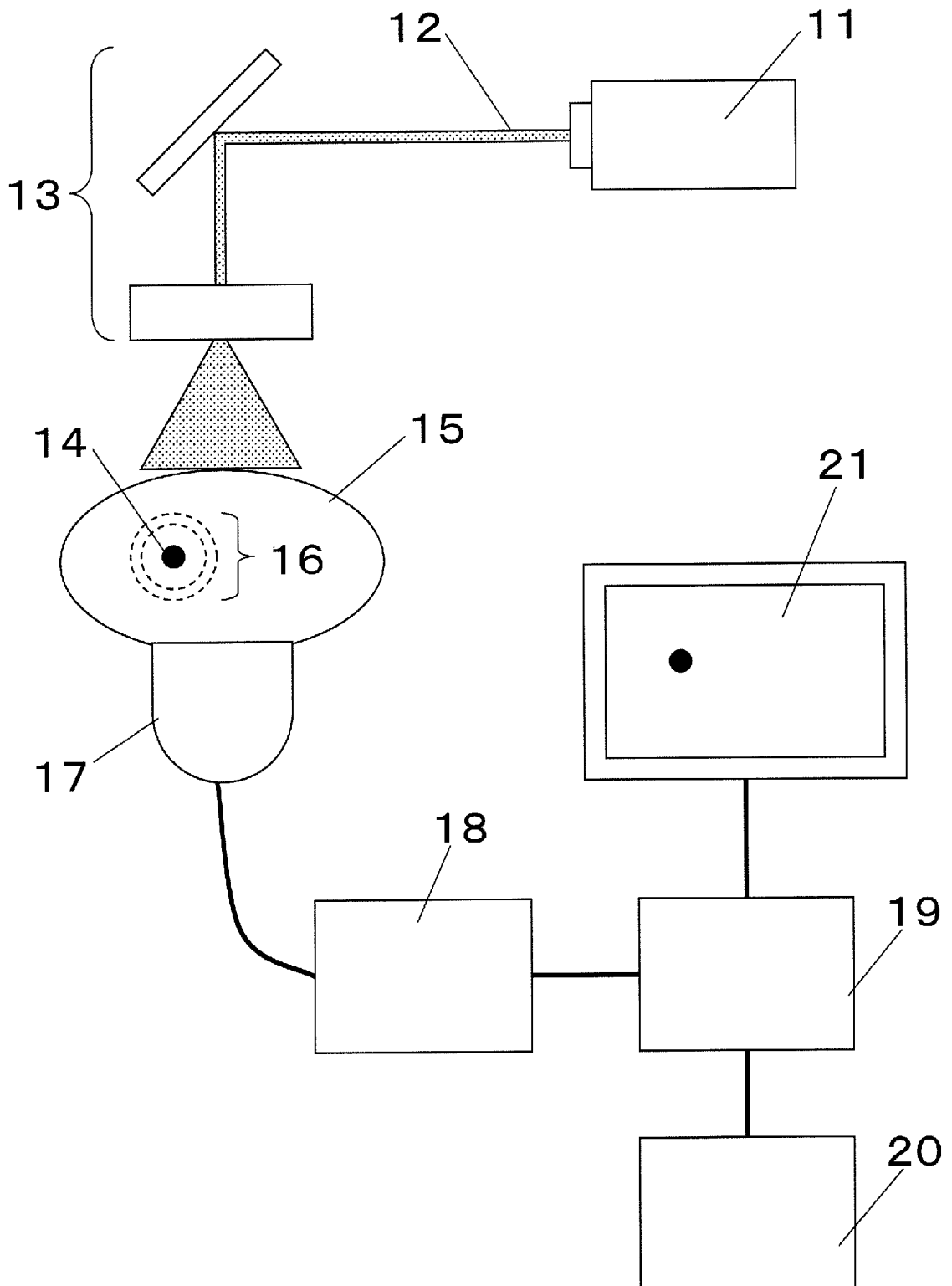

[Fig. 3]

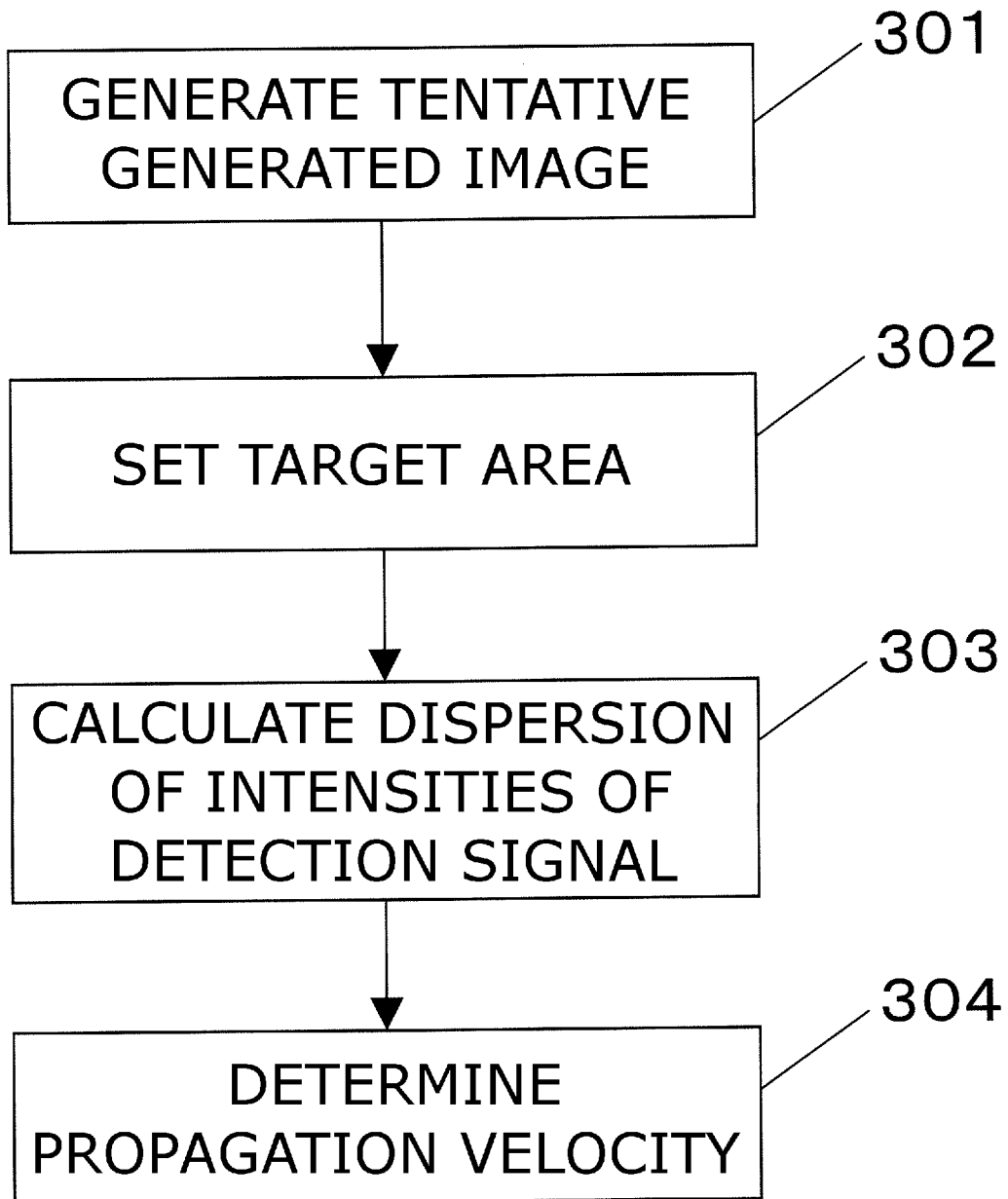

[Fig. 4A]

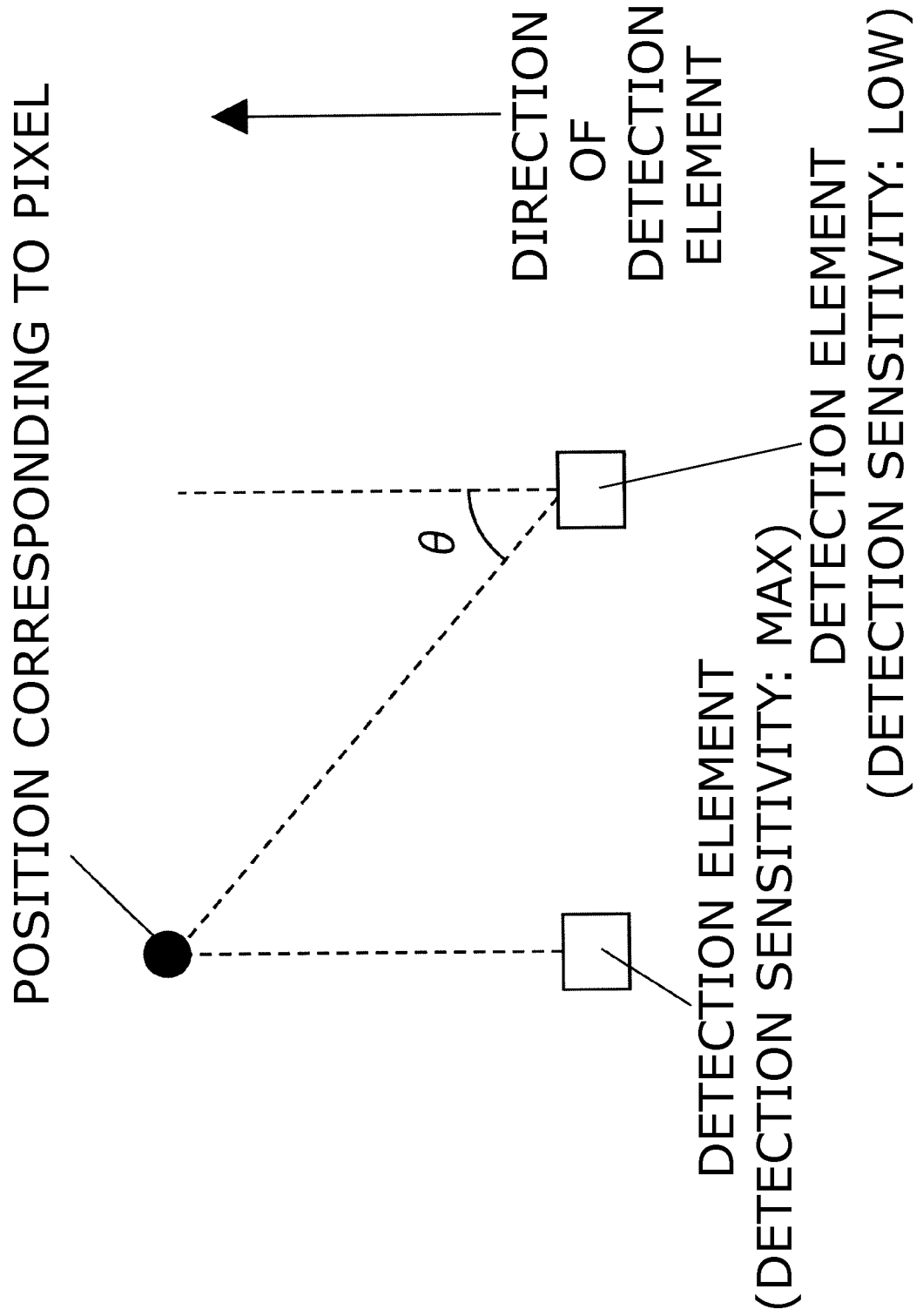

[Fig. 4B]

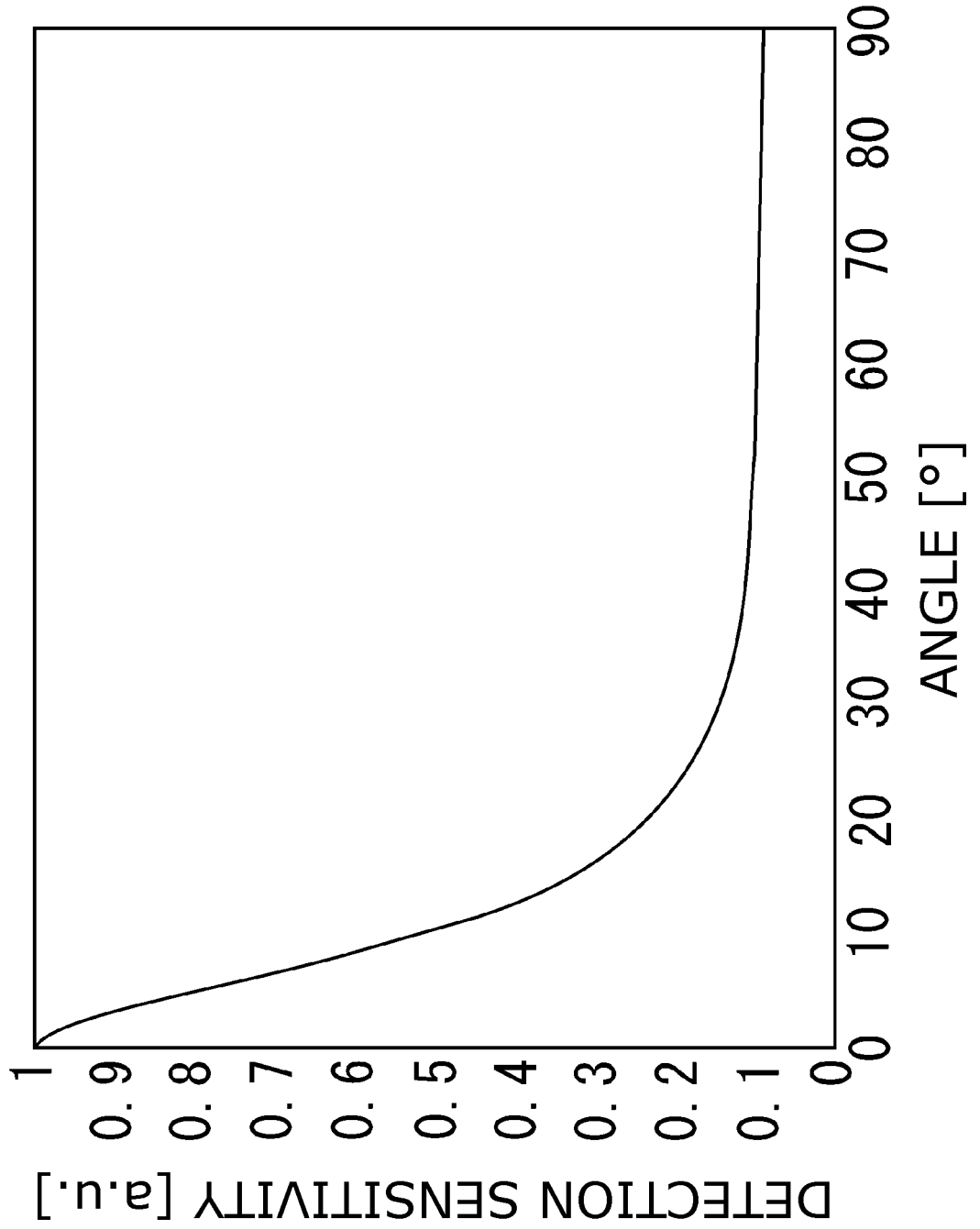

[Fig. 5A]

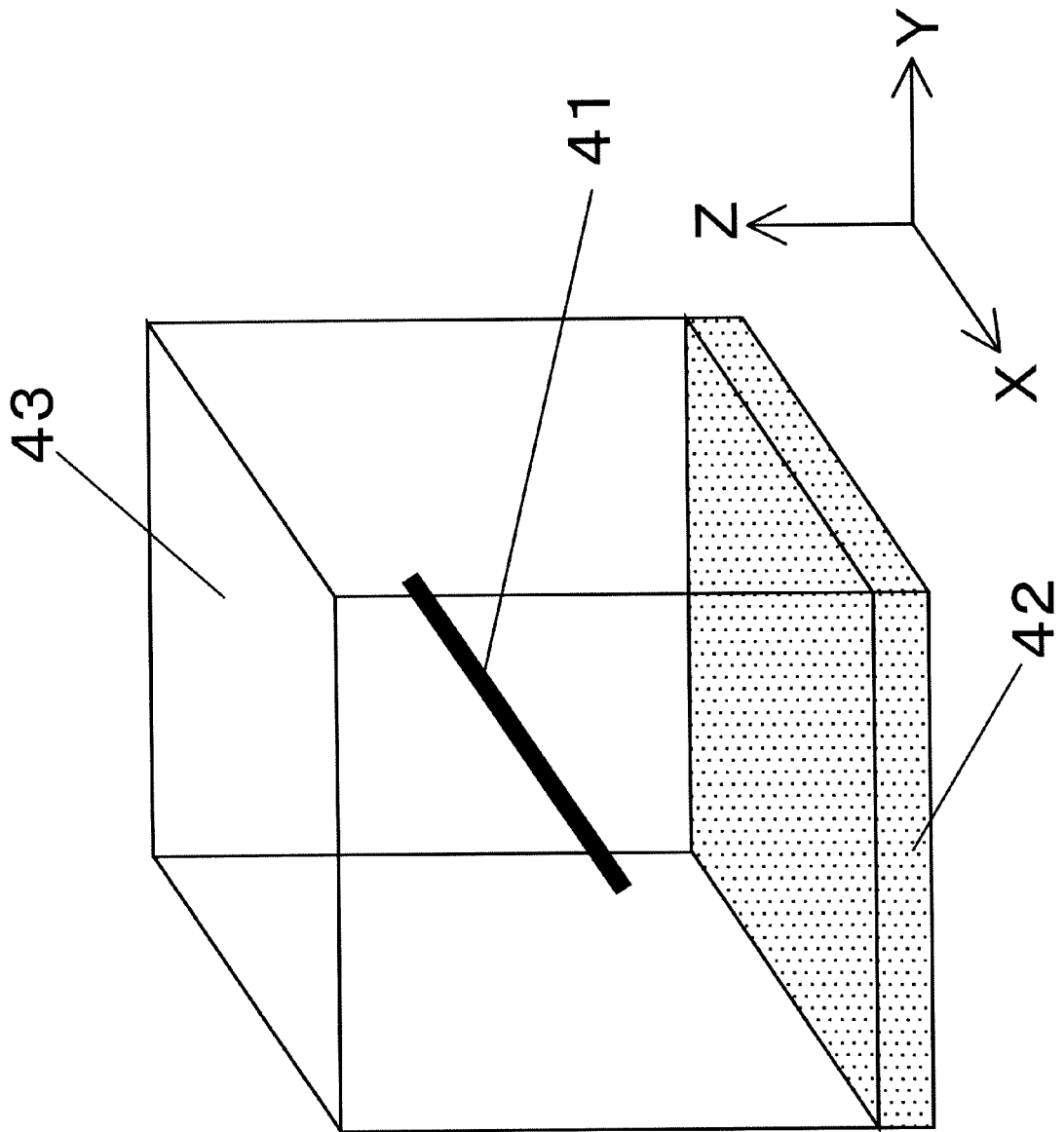

[Fig. 5B]

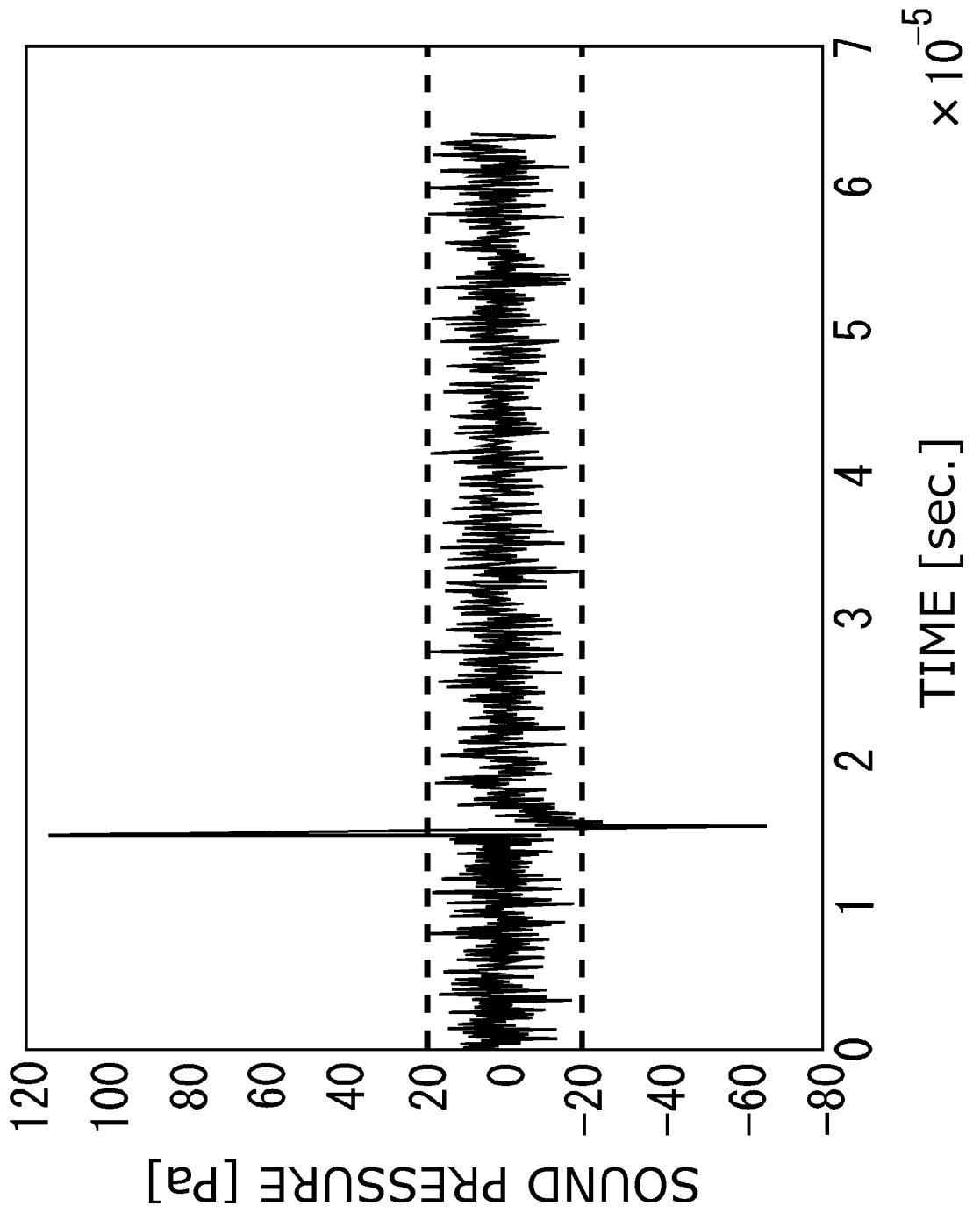

[Fig. 6]

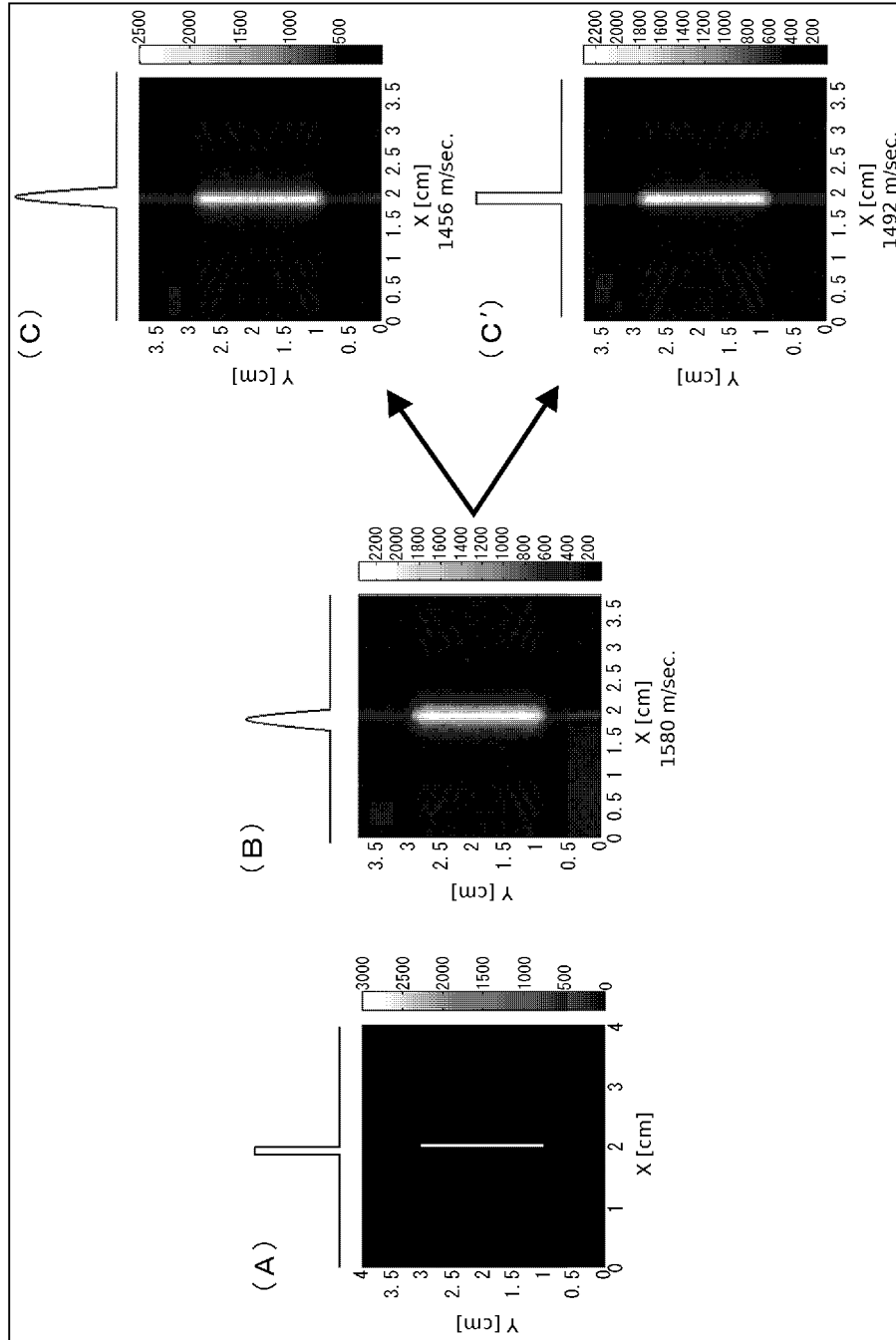

[Fig. 7A]

1540 m/sec.

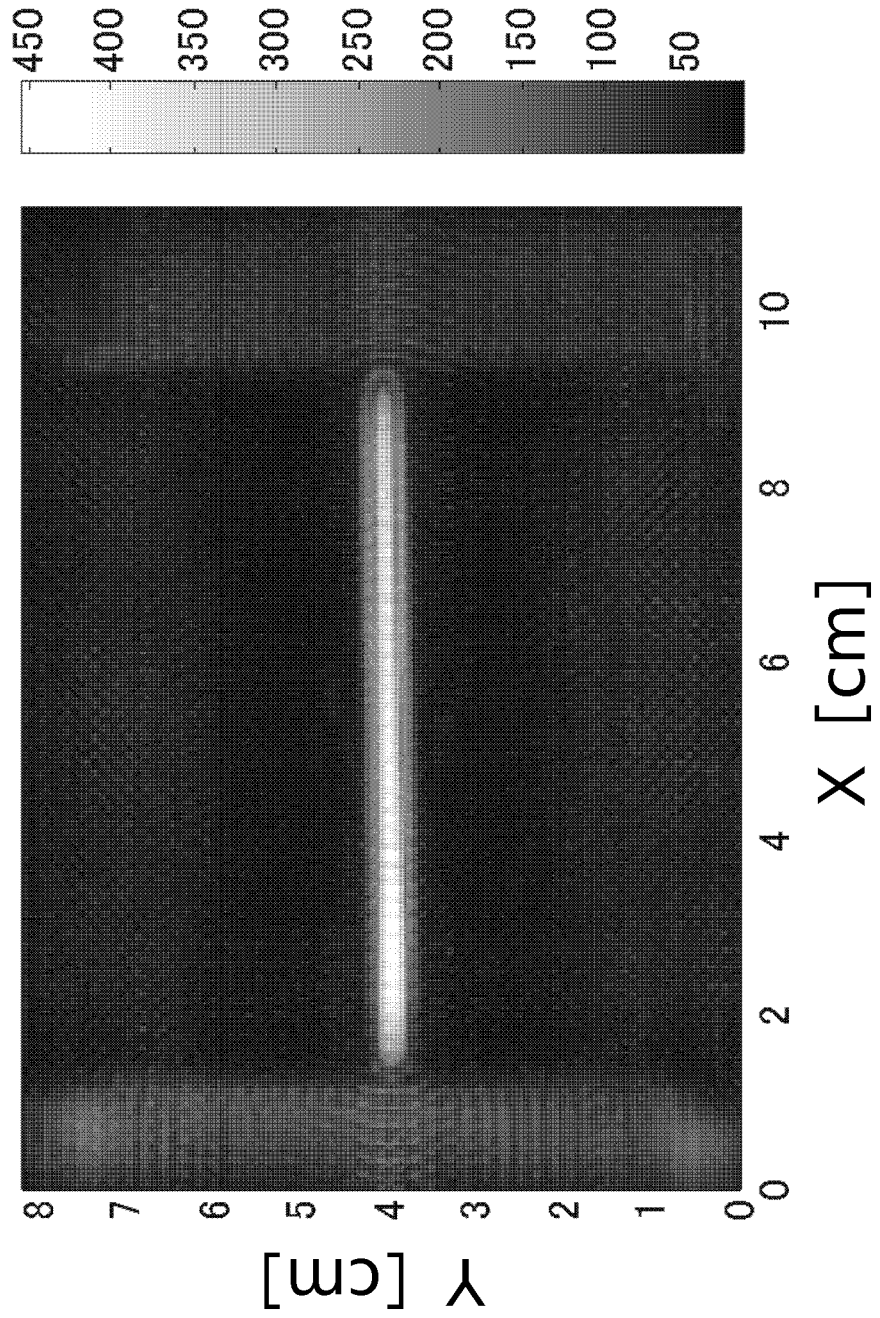

[Fig. 7B]

1454 m/sec.

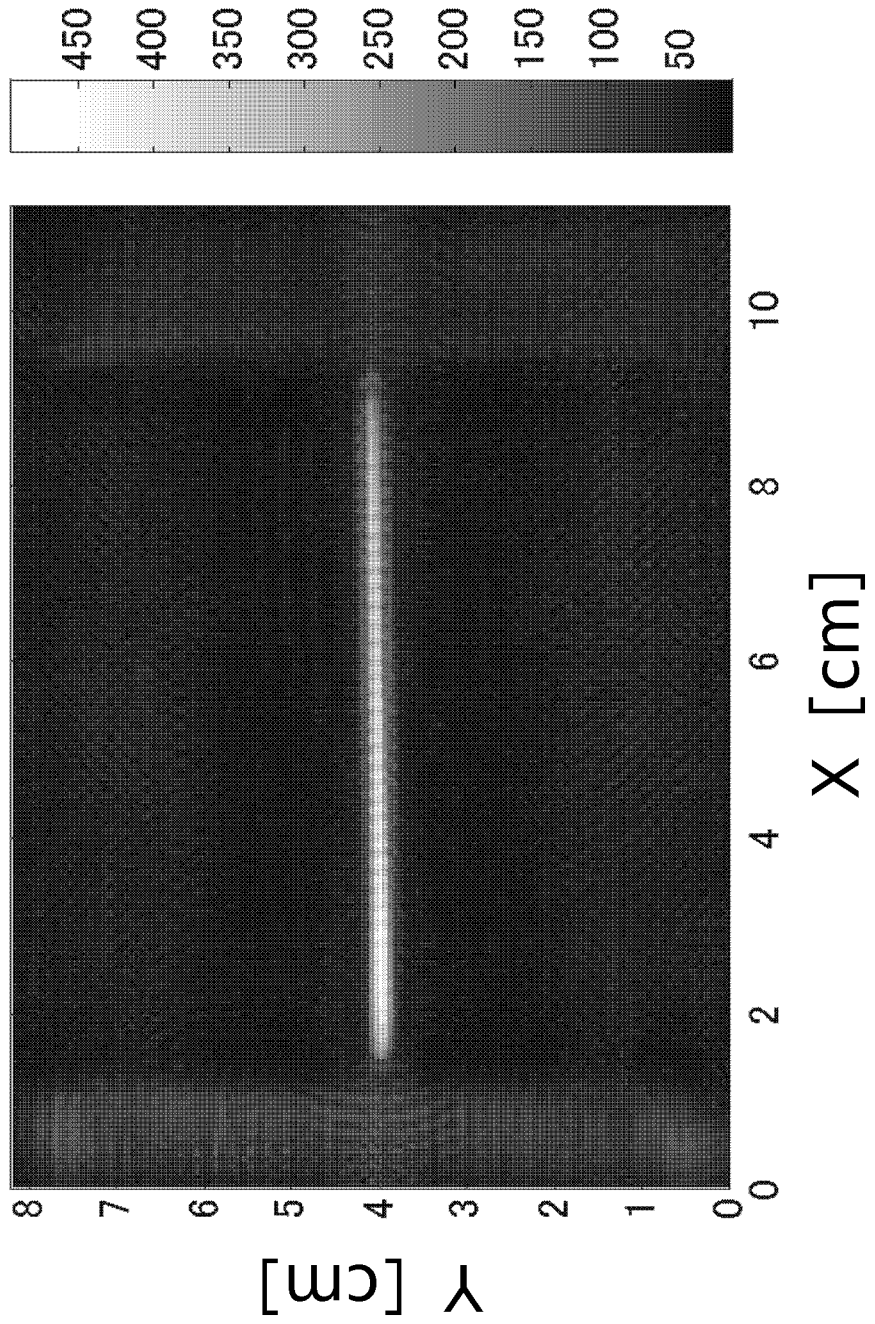

REFERENCES CITED IN THE DESCRIPTION

This list of references cited by the applicant is for the reader's convenience only. It does not form part of the European patent document. Even though great care has been taken in compiling the references, errors or omissions cannot be excluded and the EPO disclaims all liability in this regard.

Patent documents cited in the description

- JP 2000166925 A [0006]
- EP 1561424 A1 [0007]
- US 2008173093 A1 [0007]
- EP 1262148 A1 [0007]
- JP 2007301154 A [0007]

Non-patent literature cited in the description

- Review of Scientific Instruments. AIP, 17 April 2006, vol. 77, 041101-1, 041101-22 [0007]

专利名称(译)	图像生成装置，图像生成方法和程序		
公开(公告)号	EP2510382B1	公开(公告)日	2018-04-11
申请号	EP2010795071	申请日	2010-12-08
[标]申请(专利权)人(译)	佳能株式会社		
申请(专利权)人(译)	佳能株式会社		
当前申请(专利权)人(译)	佳能株式会社		
[标]发明人	FUKUTANI KAZUHIKO OISHI TAKUJI		
发明人	FUKUTANI, KAZUHIKO OISHI, TAKUJI		
IPC分类号	G01S7/52 G01S7/527 G01S15/89 A61B5/00 A61B8/14		
CPC分类号	A61B5/0095 A61B5/0073 A61B5/4312 A61B5/7225 A61B8/469 A61B8/5207 A61B8/5215 G01S7/52046 G01S7/527 G01S15/8906 G01S15/8965		
代理机构(译)	TBK		
优先权	2009281452 2009-12-11 JP		
其他公开文献	EP2510382A1		
外部链接	Espacenet		

摘要(译)

本发明的图像生成装置具有确定单元，该确定单元在对象内部的区域的一部分中设置目标区域，执行处理以基于从每个检测元件到目标区域的距离来调整每个检测信号的相位。临时速度，并且针对多个暂定速度计算调整相位的多个检测信号的强度的分散，并且将多个临时速度中的强度分散最小的速度确定为传播速度。

$$CF = \frac{\left| \sum_{i=0}^{N-1} S(i) \right|^2}{N \sum_{i=0}^{N-1} |S(i)|^2} \quad (101)$$