



(11) **EP 2 432 894 B1**

(12) **EUROPEAN PATENT SPECIFICATION**

(45) Date of publication and mention of the grant of the patent:
27.01.2016 Bulletin 2016/04

(51) Int Cl.:
C12Q 1/54 ^(2006.01) **A61B 5/00** ^(2006.01)
G01N 33/487 ^(2006.01)

(21) Application number: **10725240.5**

(86) International application number:
PCT/GB2010/000992

(22) Date of filing: **17.05.2010**

(87) International publication number:
WO 2010/133831 (25.11.2010 Gazette 2010/47)

(54) **GLUCOSE SENSOR CALIBRATION METHOD**

GLUCOSESENSORS KALIBRIERVERFAHREN

MÉTHODE DE CALIBRAGE DE CAPTEUR GLUCOSE

(84) Designated Contracting States:
AL AT BE BG CH CY CZ DE DK EE ES FI FR GB GR HR HU IE IS IT LI LT LU LV MC MK MT NL NO PL PT RO SE SI SK SM TR

(30) Priority: **18.05.2009 US 213208 P**

(43) Date of publication of application:
28.03.2012 Bulletin 2012/13

(73) Proprietor: **LIGHTSHIP MEDICAL LIMITED**
London
W1S 2LQ (GB)

(72) Inventors:
• **CRANE, Barry, Colin**
Oxfordshire OX15 6NF (GB)
• **PATERSON, William**
Oxfordshire OX11 7DH (GB)

(74) Representative: **Simons, Amanda Louise**
J A Kemp
14 South Square
Gray's Inn
London WC1R 5JJ (GB)

(56) References cited:
EP-A1- 0 560 336 WO-A1-2008/001091

EP 2 432 894 B1

Note: Within nine months of the publication of the mention of the grant of the European patent in the European Patent Bulletin, any person may give notice to the European Patent Office of opposition to that patent, in accordance with the Implementing Regulations. Notice of opposition shall not be deemed to have been filed until the opposition fee has been paid. (Art. 99(1) European Patent Convention).

Description

Field of the Invention

[0001] The present invention relates to a method of calibrating a glucose sensor as well as calibration kits for use in this method and sensor kits which can be calibrated by this method.

Background to the Invention

[0002] The use of glucose sensors in the medical field is widespread. The regular monitoring of blood glucose levels of diabetic patients at home as well as the use of glucose monitoring in intensive care units are two primary examples. The usual aim in developing a glucose sensor is to produce a digital electronic signal, which is proportional to the glucose concentration. The sensor usually comprises two main components, a chemical or biological part that reacts or complexes with the glucose (ideally specifically) to form new chemical or biological products or changes in energy that can be detected by means of the second component, a transducer. The chemical/biological component can be said to act as a receptor/indicator for glucose. A variety of transduction methods can be used including electrochemical (such as potentiometric, amperometric, conductimetric, impedimetric), optical, calorimetric and acoustic. After transduction the signal is usually converted to an electronic digital signal.

[0003] Since the signal generated by the chemical/biological reaction with the analyte is usually dependent not only on the concentration of the analyte but also on the characteristics of the sensor itself, such sensors usually require calibration before they can be utilised quantitatively. The way in which the signal varies with the analyte concentration determines the shape of the calibration curve (signal versus analyte concentration) and may define the number of calibration points. Typical calibration curves can be straight line, exponential, s-shaped etc and the principal of calibration applies to all methodologies of transduction for chemical or biological sensors.

[0004] Ideally, the sensor should be calibrated just before its use since some sensor characteristics that can affect the calibration curve vary with time (ageing effect). It is often the case that the time between sensor manufacture and use can be many months, so calibration at the point of manufacture can lead to inaccuracies in the end result. This means that the attendant clinician or nurse, or the home user, will be required to perform the calibration themselves. In order to maximise user compliance, the calibration process should be simple to perform, ideally invisible to the person performing the calibration, and be quickly completed.

[0005] Typical calibration techniques currently in use require the sensor to be inserted into three solutions having differing, but known, glucose concentrations (one of which may be zero), a reading to be taken for each solution, and a calibration curve to be generated. Since

glucose has a tendency to degrade when sterilised in an aqueous solution, commonly the glucose solutions must be made up at the time of calibration by the addition of solid glucose to water or a solution such as saline. The entire calibration process is therefore both complicated and time consuming. Calibration of many currently available glucose sensors could 25 minutes or more to complete. There is therefore a need for a more rapid calibration technique for a glucose sensor, in order to improve user compliance.

[0006] EP 0 560 336 discloses a catalyst made from phosphate and a biosensor including the same.

Summary of the Invention

[0007] The present inventors have found that the time needed for calibration of a glucose sensor can be reduced by preparing the calibration solutions in a particular manner. Specifically, the calibration solutions are prepared by the addition of both alpha and beta glucose to water or an aqueous solution.

[0008] As is well known, glucose exists in two predominant forms (isomers), termed the alpha and beta forms. In aqueous solution, the two forms will equilibrate by mutarotation of the glucose molecule. The resulting ratio of the two forms will be approximately 64:36 (beta:alpha). In the solid state, however, glucose is usually supplied in the alpha form. This means that when alpha glucose is added to water or an aqueous solution, it takes a period of time for the two forms to equilibrate (full equilibration can take a matter of hours).

[0009] Glucose sensors contain a receptor which has an affinity for glucose. Such receptors typically also have a greater affinity for either the alpha or beta form. This means that when calibration is carried out by the usual technique of addition of alpha glucose to water, the rate at which the sensor signal stabilises in the resulting solution is dependent on the rate of mutarotation.

[0010] The present inventors have shown that by the preparation of calibration solutions for a glucose sensor by adding both the alpha and beta forms to water or an aqueous solution, the rate of stabilisation of the sensor signal and hence the rate of calibration can be reduced.

[0011] The present invention accordingly provides a method of calibrating a glucose sensor, which method comprises:

- (a) preparing a first glucose-containing calibration solution by combining water or an aqueous solution with alpha and beta glucose, the alpha and beta glucose being provided in solid form;
- (b) exposing a glucose sensor to said first glucose-containing calibration solution, allowing sensor signal to stabilise, and determining the sensor output;
- (c) exposing the glucose sensor to one or more further calibration solutions having different glucose concentrations from each other and from said first glucose-containing calibration solution (said differ-

ent glucose concentration optionally being zero), allowing sensor signal to stabilise, and determining the sensor output for the or each calibration solution; and
 (d) determining a calibration curve from the sensor output data collected in steps (b) and (c);

wherein the relative amounts of the alpha and beta glucose provided in solid form are from 10 to 90 % alpha and from 90 to 10 % beta.

[0012] Step (c) may be carried out either before or after steps (a) and/or (b).

[0013] Also provided is a calibration kit comprising

- a first compartment (1) containing water or an aqueous solution;
- a second compartment (2) containing glucose in solid form; and
- an optional third compartment (3) containing glucose in solid form,

wherein at least one of the second and third compartments contains alpha glucose and at least one of the second and third compartments contains beta glucose, and wherein the first compartment is separated from the glucose-containing compartment(s) by a water impermeable dividing material;

and wherein the relative amounts of the alpha and beta glucose are from 10 to 90 % alpha and from 90 to 10 % beta.

[0014] Also provided is a glucose sensor kit comprising a glucose sensor and the calibration kit of the invention.

Brief Description of the Figures

[0015]

Figure 1 depicts a calibration kit according to the invention for carrying out a two point calibration.

Figure 2 depicts a calibration kit of the invention for carrying out a three point calibration.

Figure 3 depicts a glucose sensor for use with the invention.

Figure 4 depicts a sensor kit according to the invention.

Detailed Description of the Invention

Calibration method

[0016] Calibration may be carried out as a two point calibration, using two data points to generate the calibration curve, but is more normally carried out using three or more data points. Of these data points, one is typically generated using a zero analyte concentration. The in-

vention will largely be described with reference to a standard three point calibration using zero glucose concentration as one of the data points. However, it should be understood that the present invention can equally be used with two point calibration or four or more point calibration, and the use of a zero glucose concentration as one of the calibration points is not essential.

[0017] The method of the invention involves providing two or more, typically three, calibration solutions having differing glucose concentrations. Following any necessary preparation of each calibration solution, the sensor signal in the presence of the calibration solution is allowed to stabilize and a reading of the sensor output is taken. A suitable calibration algorithm is then used to generate a calibration curve. The skilled person would be familiar with the use of algorithms to generate a calibration curve in this manner.

[0018] Each calibration solution should have a different glucose concentration. The skilled person would be able to determine suitable concentrations of glucose for each solution. Typical concentrations should include zero and concentrations at the upper and lower end of those which are likely to be measured by the sensor. In the example of calibration of a glucose sensor for use with intensive care or diabetic patients, one calibration solution typically has a zero concentration, whilst the second and third calibration solutions typically have concentrations of, for example 5mmolL⁻¹ and 10mmolL⁻¹ respectively, or 5mmolL⁻¹ and 15mmolL⁻¹ respectively. Alternative concentrations could, however, be selected depending on the end use of the sensor. The volume of water or aqueous solution used, and the amount of glucose should be chosen according to the desired final concentrations of the calibration solutions.

[0019] At least one, and preferably at least two, more preferably all, of the glucose containing calibration solutions are prepared by mixing water or an aqueous solution with solid glucose, typically at the point of use. The water or aqueous solution may be pure water, saline or an isotonic solution. Isotonic solutions are preferred. The glucose comprises both alpha and beta glucose. Both forms of glucose are commercially available. For example, beta glucose is available from TCI Europe BV (product code G0047, CAS no. 28905-12-6) and can be produced in accordance with the methods described by Whistler and Buchanan (The Journal of Biological Chemistry 1938 "Preparation of *-glucose").

[0020] The alpha and beta glucose may be mixed prior to addition to the water or aqueous solution, or they may be added separately. If added separately, this addition may be simultaneous or at different times. Preferably, the alpha and beta glucose are mixed prior to addition to the water or aqueous solution, or are added at the same or substantially the same time. The glucose may be provided in the form of a powder or tablet or, if desired, a slow release capsule. Each tablet or capsule may contain both alpha and beta glucose, or separate tablets or capsules containing the alpha and beta glucose may be pro-

vided.

[0021] The proportion of alpha to beta glucose is preferably at or about the equilibrium level of 36% alpha to 64% beta, for example about 30 to 40% alpha and about 60 to 70% beta. However, the relative amounts of alpha and beta glucose can vary from 10 to 90%, preferably 20 to 70% and more preferably 25 to 50% alpha; and from 10 to 90%, preferably 30 to 80% and more preferably 50 to 75% beta.

[0022] In one embodiment of the invention, the solution is mixed after addition of the glucose in order to increase the rate of dissolution. Mixing not only helps to speed up the calibration process, but also ensures that the entirety of the solid glucose is dissolved in the calibration solution. This is important in providing an accurate calibration.

[0023] A number of different mixing arrangements are provided, including mechanical means, magnetic or electromagnetic and ultra-sonication. For example, a moveable magnetic paddle may be provided within the first calibration compartment and an electromagnet provided around the compartment. Movement of the electromagnetic field generates movement of the paddle and causes mixing of the contents of the chamber. Alternatively, a mechanically operated paddle can be used. Particular embodiments of mixing means are further described in WO 2008/001091.

[0024] Following preparation of the calibration solution, the sensor is exposed to the solution and an output reading taken. In one embodiment, the sensor is in contact with the water or aqueous solution prior to addition of the glucose. In an alternative embodiment, the glucose is added in a first step and the sensor is subsequently exposed to the resulting solution. The use of a mixture of alpha and beta glucose ensures more rapid stabilization of the sensor output reading and enables the reading to be made more quickly.

[0025] The present invention enables calibration of a glucose sensor to be carried out very quickly. For example, a sensor output reading can typically be taken at a period of up to 5 minutes, preferably up to 2 minutes, 90 seconds or even up to 60 seconds after addition of the solid glucose to the water or aqueous solution. The entire calibration process may therefore be complete in up to 10 minutes, for example up to 5 minutes or even up to 2 minutes. These short times are achieved because the use of a mixture of alpha and beta glucose leads to an equilibrium being formed in the solution very quickly. Where the equilibrium proportions of alpha and beta glucose are used (36:64 alpha:beta), equilibrium is achieved as soon as the glucose is dissolved in the water or aqueous solution. Achieving a stable reading from the sensor is then dependent only on the response time of the sensor. The formation of an equilibrium in the solution is no longer necessarily a rate determining step in the calibration process.

[0026] In one embodiment of the invention, the various calibration solutions may be prepared separately, by addition of the relevant amount of glucose to separate vol-

umes of water or aqueous solution. However, in a preferred embodiment, a single volume of water or aqueous solution is used to provide two or more, preferably at least three and most preferably all, of the calibration solutions.

In this embodiment, typically a zero-glucose calibration solution is provided comprising water or an aqueous solution having substantially zero glucose concentration. An amount of solid glucose, comprising both alpha and beta glucose, is then added to this solution to provide a first glucose-containing calibration solution having a first glucose concentration. A further amount of glucose is then added to provide a second glucose-containing calibration solution having a second glucose concentration. In this embodiment, the method comprises at least the following steps:

- exposing the sensor to a zero-glucose calibration solution comprising water or an aqueous solution and containing no glucose and determining the sensor output;
- preparing a first glucose-containing calibration solution by combining said zero-glucose calibration solution with alpha and beta glucose, the alpha and beta glucose being provided in solid form;
- exposing the glucose sensor to said first glucose-containing calibration solution and determining the sensor output;
- preparing a second glucose-containing calibration solution by adding a further amount of alpha and beta glucose to said first glucose-containing calibration solution, the alpha and beta glucose being provided in solid form;
- determining the sensor output for the resulting second glucose-containing solution; and
- determining a calibration curve from the sensor output data obtained.

[0027] In one aspect of this embodiment, the steps of adding glucose to the solution are carried out with the sensor already in position within the solution. In this aspect, the sensor is immediately exposed to the resulting calibration solution as soon as addition has taken place. No action is therefore required on behalf of the user to expose the sensor to the solutions. This aspect assists in reducing the overall time taken to calibrate the sensor since the sensor output can be read as soon as the signal has stabilized.

[0028] Further details of particular methods of carrying out the method of the invention are discussed with regard to the particular embodiments below.

Calibration Kit

[0029] The invention also provides a calibration kit for use in the method of the invention. The calibration kit includes at least two compartments, the first containing the water or aqueous solution and the second and optional further compartments containing solid glucose.

The kit is used by inserting the glucose sensor into the first compartment and, typically, determining the sensor output. The material dividing the first and second compartments is then broken to enable mixing of the glucose and the water or aqueous solution, thus providing a glucose-containing calibration solution having a chosen glucose concentration. Once mixing has taken place, the sensor output is again determined. This provides two calibration points, which can be used to generate a calibration curve.

[0030] In a typical embodiment, the alpha and beta glucose are provided together in the same compartment, usually the alpha and beta glucose are mixed. It is also envisaged, however, that the alpha and beta glucose are provided in separate compartments. In this case, the breakable material separating the first compartment from both the alpha glucose compartment and the beta glucose compartment are broken before the second sensor output reading is taken. Typically, both compartments are accessed at substantially the same time, to avoid any time delay in the equilibration of the resulting glucose solution. The further embodiments described herein refer to the alpha glucose and beta glucose being present in the same compartment.

[0031] The number of compartments present in the calibration kit will depend on (a) whether the alpha and beta glucose are provided in the same or different compartments, and (b) the number of calibration points to be used. In the preferred calibration kit in which the alpha and beta glucose are provided in the same compartment, a three point calibration will typically involve two separate glucose-containing compartments, each of which is separated from the first compartment by a water impermeable dividing material.

[0032] In order to provide improved storage stability, the solid glucose present in the calibration kit is typically stored in an inert gas atmosphere. This helps to avoid oxygen-induced degradation of the glucose.

[0033] The dividing material separating the glucose containing compartment(s) from the water containing compartment may be any material which can be broken, ruptured or removed causing the contents of the first and second compartments to mix. In one embodiment, the dividing material is an elastomeric material which is maintained under tension so that on piercing with a needle the material will be fully ruptured. Natural or synthetic rubbers are examples of such materials. In an alternative embodiment, the material is rigid, but is scored with fracture lines such that on piercing with a needle it readily fractures into components. Plastics and ceramics are examples of suitable rigid materials. Both of these types of dividing material provide a large opening between the first and second compartments, allowing quick mixing of the contents of the compartments. Alternative dividing materials include metal foils (e.g. aluminium foil) which may be coated with plastic.

[0034] The dividing material should be impermeable to water and glucose to avoid leakage between the two

compartments of the calibration chamber. In one embodiment, one surface of the dividing material is metallised to assist in preventing water diffusion. The metallised surface is typically in contact with the second compartment which is preferably under an inert gas atmosphere.

[0035] The calibration kit of the invention will be described below with reference to a number of different embodiments, but the invention is not intended to be limited to these particular embodiments.

Embodiment 1

[0036] A first embodiment of a calibration kit according to the invention is depicted in Figure 1. This calibration kit provides a two point calibration. The calibration kit 10 comprises two compartments 101 and 102, which are separated by a water-impermeable dividing material 11 e.g. a breakable dividing material. The first compartment 101 contains water or an aqueous solution. Typically, this compartment contains an isotonic solution and does not contain glucose. Thus, sensing of the glucose concentration in this compartment typically provides a zero reading.

[0037] The second compartment contains a source of glucose 12 in solid form. In this embodiment, the second compartment contains a mixture of alpha and beta forms of glucose. The second compartment may be under inert gas atmosphere (e.g. dry nitrogen) to avoid oxygen-induced irradiation degradation in the case that the calibration kit is sterilized by irradiation.

[0038] Calibration of a glucose sensor can be carried out by exposing the sensor to the first compartment 101 containing the water or aqueous solution. In the embodiment depicted in Figure 1, the sensor is depicted within compartment 101. However, in alternative embodiments, the sensor may be provided separately. In this case, to enable the sensor to be inserted, outer wall 13 of the first compartment is typically at least in part piercable. For example, the outer wall 13 may be a septum which can be pierced by a needle. The sensor can be inserted into the first compartment through or within the needle. Once the sensing region is in place within the first compartment, a first reading of the sensor output is taken.

[0039] In an alternative aspect of this embodiment, a seal is provided between the sensor and the first compartment. Breaking the seal, e.g. by movement of the sensor or a part of the outer wall 13 of the first compartment, causes the content of the first compartment to flow around the sensor, thus exposing the sensor to the water or aqueous solution.

[0040] The dividing material separating first and second compartments is then broken or removed allowing the contents of these compartments to mix. In order to maintain sterility, the dividing material is typically broken or removed without opening the sealed calibration kit. Thus, the material is broken for example by movement of needle 31 in the direction of the arrow through the dividing material. This can be achieved, for example, by

depression of a plunger attached to needle 31, either manually or by an automated process. The needle is here of substantially the same circumference as the second compartment, such that the analyte is pushed through the dividing material into the first compartment, aiding mixing.

[0041] In an alternative aspect of this embodiment, the sensor is inserted into the first compartment within a needle, and the needle, containing the sensor, can then be pushed forwards to rupture the dividing material.

[0042] Once the contents of the two compartments are mixed, a further calibration solution is provided having a greater concentration of glucose than the first calibration solution. The sensor output from a reading taken on this solution can be taken as soon as the sensor signal stabilises, thereby providing a second calibration point. The use of both alpha and beta glucose, rather than alpha glucose alone, provides more rapid stabilisation and therefore a reading of the sensor output can be made more quickly.

[0043] In an automated process, one or more of the steps of exposing the sensor to the first compartment and removing or breaking dividing material 11 may be machine-driven. A stepper motor or a stepper motor attached to a lead screw may be used in this regard.

[0044] Invasive sensors typically operate in a temperature range of 35-39C. However, calibration is normally carried out at room temperature. Many sensors are sensitive to temperature variation, in which case a calibration curve generated at room temperature will be shifted to a different set of values at, say, 37C. In one embodiment, therefore, a heating element (14 in Figure 1) may be provided to increase the temperature within the calibration chamber to 37C prior to calibration.

[0045] A number of alternative embodiments of the invention are described below. Each of these embodiments is the same as the first embodiment, except as particularly described.

Embodiment 2

[0046] A preferred calibration will include three calibration points in order to provide a better fit in the calibration curve. To provide three calibration points, three separate calibration solutions having different concentrations of glucose are needed.

[0047] In one embodiment, a three point calibration is provided by including in the second compartment 102 a slow release capsule (not depicted) designed to release glucose into the water or aqueous solution only after the lapse of a period of time. The slow release capsule in this embodiment is provided in addition to the glucose source 12. On rupture/breakage/removal of the dividing material 11, the glucose source 12 will dissolve in the water or aqueous solution to allow a reading of the sensor to be taken for this first glucose-containing solution. The slow release capsule is designed such that its contents are released into the solution only after this reading, cor-

responding to the first glucose-containing solution, has been taken. Thus, a monitor detecting sensor output will observe a first increase in glucose concentration as the first glucose source dissolves, followed by a second distinct increase in glucose concentration following break-up of the slow release capsule.

[0048] In order to avoid long calibration times, capsules which dissolve in the range of from about 1 to 5 minutes are preferred. Polyethylene oxide capsules are examples of suitable materials. The precise release time of the capsule can be controlled by variation of the thickness of the capsule in a manner which is well known in the art.

Embodiment 3

[0049] An alternative embodiment of the calibration chamber is depicted in Figure 2. In this embodiment, three compartments, 101, 102 and 103 are present. A dividing material 11, 11a separates each compartment. This embodiment provides a three point calibration by a different means. Following taking of the first reading of the water or aqueous solution in compartment 101, dividing material 11 of the second compartment 102 is pierced by needle 31. Mixing of the contents of compartments 101 and 102 provides a first glucose-containing calibration solution. A reading of the sensor output is taken once the sensor signal stabilises. The dividing material 11a of the third compartment 103 is then pierced by needle 31a. This causes glucose 12a to mix with the first glucose-containing calibration solution to provide a second glucose-containing calibration solution with a higher glucose concentration. The third reading of the sensor output can be taken once the sensor signal stabilises.

Sensor kit

[0050] The present invention provides a sensor kit, which incorporates a glucose sensor and the calibration kit of the invention as described above. The sensor kit enables the sensor and calibration kit to be provided to the user in sterile form and in a very easy to use format. Further, the sensor kit enables the user to easily maintain sterility of the calibration kit and sensing region of the sensor during calibration.

[0051] The sensor typically has a sensing region, which is the part of the sensor which is contacted with the sample during analysis. In one embodiment, the sensing region of the sensor is located within the first compartment of the calibration kit. This means that the sensing region is in contact with the water or aqueous solution provided within that compartment. This may have advantages in terms of storage of the sensor, since some sensors are beneficially stored in solution rather than in dried form. Furthermore, on receipt of the sensor kit, the user can immediately take a reading of the sensor output for the solution in the first compartment and no further action is needed on behalf of the user to expose the sensor to the various solutions.

[0052] The nature of the sensor for use with the present invention is not particularly limited. The sensor may be an invasive or implantable sensor, or it may be for in vitro measurement of glucose content. Sensors may be designed for measurement of the glucose content of physiological fluids such as blood or interstitial fluid, or for the measurement of glucose in other sample types.

[0053] In one embodiment, the sensor is an optical sensor comprising a glucose receptor, a fluorophore associated with the glucose receptor, a light emitter and a detector. A waveguide is typically provided, for example an optical fibre, to transmit the light to and from the emitter or detector. The fluorescence of the fluorophore is altered when glucose is bound to the receptor. Thus, the binding of glucose to the receptor generates a detectable signal that is responsive to the concentration of glucose. The signal detected may be, for example, the intensity of the emitted fluorescence, or the lifetime of the fluorescence.

[0054] An example of an optical fibre glucose sensor for use with the invention is depicted in Figure 3. The sensor 1 comprises a tip 4 which may be adapted for insertion into a patient, for example insertion into a blood vessel through a cannular. The tip includes a sensing region 3 in which the glucose receptor and optionally a temperature sensor are positioned. The glucose receptor is immobilised on or in an optical fibre, such that a signal emitted by the receptor is transmitted through the optical fibre. The optical fibre extends through cable 7 to connector 8, which is adapted to mate with an appropriate monitor (not depicted). The monitor typically includes further optical cable that mates with the connector at one end and at the other bifurcates to connect to (a) an appropriate light source for the optical sensor and (b) a detector for the emitted signal. Electrical connection to any temperature sensor is also provided through connector 8 and appropriate detection equipment is provided by the monitor.

[0055] The sensing region of the sensor is typically coated with a membrane which should allow diffusion of glucose from the surrounding fluid to the receptor and, for in vivo use, should be haemocompatible.

[0056] The glucose receptor for such a fluorescent sensor may be any group or compound having an affinity for glucose. Boronic acid species are particularly envisaged for use as the glucose receptor. The skilled person in the art would be familiar with the use of boronic acid species and fluorophores in the optical detection of glucose. Examples of appropriate glucose receptor/fluorophore conjugates, however, are found in US 6,387,672, the contents of which are incorporated herein by reference in their entirety.

[0057] The receptor and fluorophore are typically immobilised to the optical fibre in a hydrogel which allows diffusion of water and glucose to the receptor compound. Cross-linked polyacrylamide or polyhydroxyethylmethacrylate (p-HEMA) are examples of hydrogels that can be used.

[0058] Further examples of sensors which are suitable

for use in the present invention are described, for example, in US 2009/0018418.

[0059] An embodiment of the sensor kit of the invention is depicted in Figure 4. The kit includes a container 20, which accommodates the sensor 1 and calibration kit 10. The calibration kit 10 is typically fixed into a locked position within the container. The sensor is contained within sensor housing 21 and is here depicted with the sensing region 3 of the sensor within the first compartment 101 of the calibration kit.

[0060] Means for breaking the dividing materials separating compartment 101 from compartments 102 and 103 are provided, for example needles 31 and 31a as depicted in Figure 2. Such means typically extend outside housing 20 to enable user manipulation of these means without breaking the seal of the container and thus without loss of sterility.

[0061] The sensor housing containing the sensor is in one aspect movable laterally within the container, i.e. in a left / right direction as depicted in Figure 4. A guide channel may be provided to ensure that movement of the sensor housing is restricted to this lateral direction and to limit free movement of the housing. In this way, the sensor can be moved within the sensor kit, for example a sensor provided outside the calibration kit 10 can be moved laterally so that it is within the calibration kit. In order to maintain sterility of the device, it is advantageous to be able to move the sensor and sensor housing without breaking the seal of the container. In the embodiment depicted in Figure 4, this can be achieved by compressing compressible arm 26. This causes the sensor housing containing the sensor to move laterally within the container. The compressible arm may be configured in the shape of a compressible bellows.

[0062] The container 20 is typically sealed with a gas permeable lid (not depicted).

[0063] Further examples of particular features and embodiments of calibration kits and sensor kits which can be used with the method of the invention are described in WO 2008/001091 and US 2009/018426.

Claims

1. A method of calibrating a glucose sensor, which method comprises:

- (a) preparing a first glucose-containing calibration solution by combining water or an aqueous solution with alpha and beta glucose, the alpha and beta glucose being provided in solid form;
- (b) exposing a glucose sensor to said first glucose-containing calibration solution, allowing sensor signal to stabilise, and determining the sensor output;
- (c) exposing the glucose sensor to one or more further calibration solutions having different glucose concentrations from each other and from

- said first glucose-containing calibration solution, allowing sensor signal to stabilise, and determining the sensor output for the or each calibration solution; and
(d) determining a calibration curve from the sensor output data collected in steps (b) and (c); wherein the relative amounts of the alpha and beta glucose provided in solid form are from 10 to 90 % alpha and from 90 to 10 % beta.
2. A method according to claim 1, wherein step (c) involves exposing the glucose sensor to two or more calibration solutions.
 3. A method according to claim 1 or 2, further comprising preparing at least one of the one or more further calibration solutions used in step (c) by combining water or an aqueous solution with alpha and beta glucose, the alpha and beta glucose being provided in solid form.
 4. A method according to any one of the preceding claims, wherein the first glucose-containing calibration solution of step (a), and optionally the or each glucose-containing calibration solution of step (c), is prepared using 25 to 50 % alpha glucose and 50 to 75 % beta glucose.
 5. A method according to any one of the preceding claims, wherein the determination of sensor output in step (b) is carried out within 2 minutes of combining the solid glucose and water or aqueous solution.
 6. A method according to any one of claims 1 to 5, wherein the method comprises at least the following steps:
 - exposing the sensor to a zero-glucose calibration solution comprising water or an aqueous solution and containing no glucose and determining the sensor output;
 - preparing a first glucose-containing calibration solution by combining said zero-glucose calibration solution with alpha and beta glucose, the alpha and beta glucose being provided in solid form;
 - exposing the glucose sensor to said first glucose-containing calibration solution and determining the sensor output;
 - preparing a second glucose-containing calibration solution by adding a further amount of alpha and beta glucose to said first glucose-containing calibration solution, the alpha and beta glucose being provided in solid form;
 - determining the sensor output for the resulting second glucose-containing solution; and
 - determining a calibration curve from the sensor output data obtained.
 7. A calibration kit comprising
 - a first compartment (1) containing water or an aqueous solution;
 - a second compartment (2) containing glucose in solid form; and
 - an optional third compartment (3) containing glucose in solid form, wherein at least one of the second and third compartments contains alpha glucose and at least one of the second and third compartments contains beta glucose, and wherein the first compartment is separated from the glucose-containing compartment(s) by a water impermeable dividing material; and wherein the relative amounts of the alpha and beta glucose are from 10 to 90 % alpha and from 90 to 10 % beta.
 8. A calibration kit according to claim 7 having both a second and a third compartment, wherein both the second and third compartments contain a mixture of alpha and beta glucose.
 9. A calibration kit according to claim 7 or 8, wherein the ratio of alpha glucose: beta glucose in the or each glucose-containing compartment is the same or different and is in the range 25:75 to 50:50.
 10. A glucose sensor kit comprising a glucose sensor and a calibration kit according to any one of claims 7 to 9.
 11. A glucose sensor kit according to claim 10, wherein the glucose sensor comprises a sensing portion comprising a receptor for glucose, said sensing portion being located within the first compartment of the calibration kit.
 12. A glucose sensor kit according to claim 10 or claim 11, wherein the glucose sensor comprises:
 - a glucose receptor having an affinity for glucose;
 - a fluorophore associated with said glucose receptor, the fluorescence of said fluorophore being altered in the presence of glucose;
 - a light emitter; and
 - a detector.

Patentansprüche

1. Verfahren zum Kalibrieren eines Glucose-Sensors, wobei das Verfahren umfasst:
 - (a) Herstellen einer ersten Glukose enthaltenden Kalibrierungslösung, indem Wasser oder eine wässrige Lösung mit Alpha- und Beta-Glu-

- cose gemischt wird, wobei die Alpha- und Beta-Glucose in einer festen Form bereitgestellt werden;
- (b) Aussetzen eines Glucose-Sensors der ersten Glucose enthaltenden Kalibrierungslösung, Ermöglichen einem Sensorsignal, sich zu stabilisieren, und Bestimmen der Sensor-Ausgabe; 5
- (c) Aussetzen des Glucose-Sensors einer oder mehrerer weiterer Kalibrierungslösungen, welche jeweils voneinander und von der ersten Glucose enthaltenden Kalibrierungslösung unterschiedliche Glucose-Konzentrationen aufweisen, Ermöglichen des Sensorsignals, sich zu stabilisieren, und Bestimmen der Sensor-Ausgabe für die oder für jede Kalibrierungslösung; und 10
- (d) Bestimmen einer Kalibrierungskurve von den Sensor-Ausgabedaten, welche in den Schritten (b) und (c) gesammelt werden; wobei der relative Anteil der Alpha- und Beta-Glucose, welche in fester Form bereitgestellt werden, bei 10 bis 90 % für Alpha und bei 90 bis 10 % für Beta liegt. 15
2. Verfahren nach Anspruch 1, wobei der Schritt (c) ein Aussetzen des Glucose-Sensors zu zwei oder mehr Kalibrierungslösungen einbezieht. 25
3. Verfahren nach Anspruch 1 oder 2, darüber hinaus ein Herstellen von mindestens einer der einen oder der mehreren weiteren Kalibrierungslösungen, welche in Schritt (c) eingesetzt werden, umfassend, indem Wasser oder eine wässrige Lösung mit Alpha- und Beta-Glucose gemischt wird, wobei die Alpha- und Beta-Glucose in einer festen Form bereitgestellt werden. 30
4. Verfahren nach einem der vorhergehenden Ansprüche, wobei die erste Glucose enthaltende Kalibrierungslösung aus Schritt (a) und optional die oder jede Glucose enthaltende Kalibrierungslösung aus Schritt (c) unter Verwendung von 25 bis 50 % Alpha-Glucose und 50 bis 75 % Beta-Glucose hergestellt wird. 35
5. Verfahren nach einem der vorhergehenden Ansprüche, wobei die Bestimmung der Sensor-Ausgabe in Schritt (b) innerhalb von 2 Minuten durch Mischen der festen Glucose und Wasser oder einer wässrigen Lösung durchgeführt wird. 40
6. Verfahren nach einem der Ansprüche 1 bis 5, wobei das Verfahren zumindest die folgenden Schritte umfasst: 45
- Aussetzen des Sensors einer Null-Glucose-Kalibrierungslösung, welche Wasser oder eine wässrige Lösung umfasst und keine Glucose enthält, und Bestimmen der Sensor-Ausgabe;
 - Herstellen einer ersten Glucose enthaltenden Kalibrierungslösung, indem die Null-Glucose-Kalibrierungslösung mit Alpha- und Beta-Glucose gemischt wird, wobei die Alpha- und Beta-Glucose in einer festen Form bereitgestellt werden;
 - Aussetzen des Glucose-Sensors der ersten Glucose enthaltenden Kalibrierungslösung und Bestimmen der Sensor-Ausgabe;
 - Herstellen einer zweiten Glucose enthaltenden Kalibrierungslösung, indem eine weitere Menge an Alpha- und Beta-Glucose der ersten Glucose enthaltenden Kalibrierungslösung hinzugefügt wird, wobei die Alpha- und Beta-Glucose in einer festen Form bereitgestellt werden;
 - Bestimmen der Sensor-Ausgabe für die sich ergebende zweite Glucose enthaltende Lösung; und
 - Bestimmen einer Kalibrierungskurve von den erhaltenen Sensor-Ausgabedaten. 50
7. Kalibrierungs-Einrichtung umfassend
- einen ersten Teilraum (1), welcher Wasser oder eine wässrige Lösung enthält;
 - einen zweiten Teilraum (2), welcher Glucose in einer festen Form enthält; und
 - einen optionalen dritten Teilraum (3), welcher Glucose in einer festen Form enthält, wobei mindestens einer von dem zweiten und dritten Teilraum Alpha-Glucose enthält und wobei mindestens einer von dem zweiten und dritten Teilraum Beta-Glucose enthält, und wobei der erste Teilraum von dem Glucose enthaltenden Teilraum bzw. von den Glucose enthaltenden Teilräumen durch ein wasserdichtes abteilendes Material getrennt ist; und wobei der relative Anteil der Alpha- und Beta-Glucose 10 bis 90 % für Alpha und 90 bis 10 % für Beta beträgt. 55
8. Kalibrierungs-Einrichtung nach Anspruch 7, welche sowohl einen zweiten als auch einen dritten Teilraum aufweist, wobei sowohl der zweite als auch der dritte Teilraum eine Mischung aus Alpha- und Beta-Glucose enthalten. 60
9. Kalibrierungs-Einrichtung nach Anspruch 7 oder 8, wobei das Verhältnis von Alpha-Glucose:Beta-Glucose in dem oder in jedem Glucose enthaltenden Teilraum dasselbe oder unterschiedlich ist und in dem Bereich von 25:75 bis 50:50 liegt. 65
10. Glucose-Sensor-Einrichtung, welche einen Glucose-Sensor und eine Kalibrierungs-Einrichtung nach einem der Ansprüche 7 bis 9 umfasst. 70

11. Glucose-Sensor-Einrichtung nach Anspruch 10, wobei der Glucose-Sensor einen Erfassungsabschnitt umfasst, welcher einen Rezeptor für Glucose umfasst, wobei der Erfassungsabschnitt in dem ersten Teilraum der Kalibrierungs-Einrichtung angeordnet ist.

12. Glucose-Sensor-Einrichtung nach Anspruch 10 oder Anspruch 11, wobei der Glucose-Sensor umfasst:

- einen Glucose-Rezeptor, welcher eine Affinität für Glucose aufweist;
- ein Fluorophor, welches dem Glukose-Rezeptor zugeordnet ist, wobei sich die Fluoreszenz des Fluorophors bei dem Vorhandensein von Glucose ändert;
- ein Licht-Emitter; und
- ein Detektor.

Revendications

1. Procédé d'étalonnage d'un capteur de glucose, lequel procédé comprend les étapes consistant à :

(a) préparer une première solution d'étalonnage contenant du glucose, par réunion d'eau ou d'une solution aqueuse avec de l'alpha- et du bêta-glucose, l'alpha- et le bêta-glucose étant fournis sous forme solide ;

(b) exposer un capteur de glucose à ladite première solution d'étalonnage contenant du glucose, laisser se stabiliser le signal du capteur et déterminer le signal de sortie du capteur ;

(c) exposer le capteur de glucose à une ou plusieurs autres solutions d'étalonnage ayant des concentrations de glucose qui diffèrent entre elles et de ladite première solution d'étalonnage contenant du glucose, laisser se stabiliser le signal du capteur et déterminer le signal de sortie du capteur pour la ou chaque solution d'étalonnage ; et

(d) construire une courbe d'étalonnage à partir des données de sortie du capteur, collectées dans les étapes (b) et (c) ;

les quantités relatives de l'alpha- et du bêta-glucose fournis sous forme solide valant de 10 à 90 % d'alpha-glucose et de 90 à 10 % de bêta-glucose.

2. Procédé selon la revendication 1, dans lequel l'étape (c) comprend l'exposition du capteur de glucose à deux ou plus de deux solutions d'étalonnage.

3. Procédé selon la revendication 1 ou 2, comprenant en outre la préparation d'au moins une desdites une ou plusieurs autres solutions d'étalonnage utilisées

dans l'étape (c) par réunion d'eau ou d'une solution aqueuse avec de l'alpha- et du bêta-glucose, l'alpha- et le bêta-glucose étant fournis sous forme solide.

4. Procédé selon l'une quelconque des revendications précédentes, dans lequel on prépare la première solution d'étalonnage contenant du glucose de l'étape (a), et en option la ou chaque solution d'étalonnage contenant du glucose de l'étape (c) en utilisant 25 à 50 % d'alpha-glucose et 50 à 75 % de bêta-glucose.

5. Procédé selon l'une quelconque des revendications précédentes, dans lequel on effectue la détermination du signal de sortie du capteur dans l'étape (b) en l'espace de minutes après la réunion du glucose solide et d'eau ou de solution aqueuse.

6. Procédé selon l'une quelconque des revendications 1 à 5, dans lequel le procédé comprend au moins les étapes suivantes :

exposition du capteur du capteur à une solution d'étalonnage à zéro-glucose, comprenant de l'eau ou une solution aqueuse et ne contenant pas de glucose, et la détermination du signal de sortie du capteur ;

- préparation d'une première solution d'étalonnage contenant du glucose, par réunion de ladite solution d'étalonnage à zéro-glucose avec de l'alpha- et du bêta-glucose, l'alpha- et le bêta-glucose étant fournis sous forme solide ;

- exposition du capteur de glucose à ladite première solution d'étalonnage contenant du glucose et détermination du signal de sortie du capteur ;

- préparation d'une deuxième solution d'étalonnage contenant du glucose, par addition d'une nouvelle quantité d'alpha- et de bêta-glucose à ladite première solution d'étalonnage contenant du glucose, l'alpha- et le bêta-glucose étant fournis sous forme solide ;

détermination du signal de sortie du capteur pour la deuxième solution résultante contenant du glucose ; et

construction d'une courbe d'étalonnage à partir des données de sortie du capteur obtenues.

7. Nécessaire d'étalonnage comprenant :

un premier compartiment (1) contenant de l'eau ou une solution aqueuse ;

- un deuxième compartiment (2) contenant du glucose sous forme solide ; et un troisiè-

- me compartiment optionnel (3) contenant du glucose sous forme solide, dans lequel au moins un des deuxième et troisième compartiments contient de l'alpha-glucose et au moins un des deuxième et troisième compartiments contient du bêta-glucose, et dans lequel le premier compartiment est séparé du/des compartiment(s) contenant du glucose par un matériau de séparation imperméable à l'eau ; et dans lequel les quantités relatives de l'alpha- et du bêta-glucose valent de 10 à 90 % d'alpha-glucose et de 90 à 10 % de bêta-glucose.
- 5
10
15
8. Nécessaire d'étalonnage selon la revendication 7, comportant à la fois un deuxième et un troisième compartiment, l'un et l'autre des deuxième et troisième compartiments contenant un mélange d'alpha- et de bêta-glucose.
- 20
9. Nécessaire d'étalonnage selon la revendication 7 ou 8, dans lequel le rapport alpha-glucose:bêta-glucose dans le ou chaque compartiment contenant du glucose est le même ou différent et est dans la plage de 25:75 à 50:50.
- 25
10. Nécessaire de capteur de glucose comprenant un capteur de glucose et un nécessaire d'étalonnage selon l'une quelconque des revendications 7 à 9.
- 30
11. Nécessaire de capteur de glucose selon la revendication 10, dans lequel le capteur de glucose comprend une partie capteur comprenant un récepteur de glucose, ladite partie capteur se trouvant dans le premier compartiment du nécessaire d'étalonnage.
- 35
12. Nécessaire de capteur de glucose selon la revendication 10 ou la revendication 11, dans lequel le capteur de glucose comprend :
- 40
- un récepteur de glucose ayant une affinité pour le glucose ;
 - un fluorophore associé audit récepteur de glucose, la fluorescence dudit fluorophore étant modifiée en présence de glucose ;
 - un photoémetteur ; et
 - un détecteur.
- 45
50

55

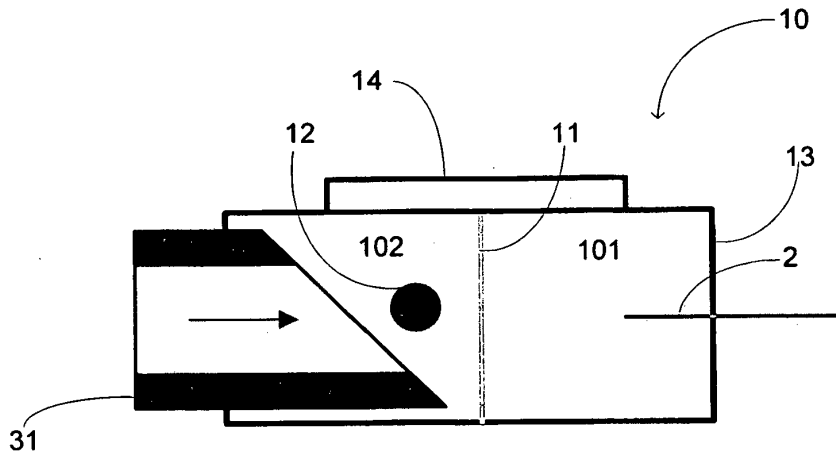

Figure 1

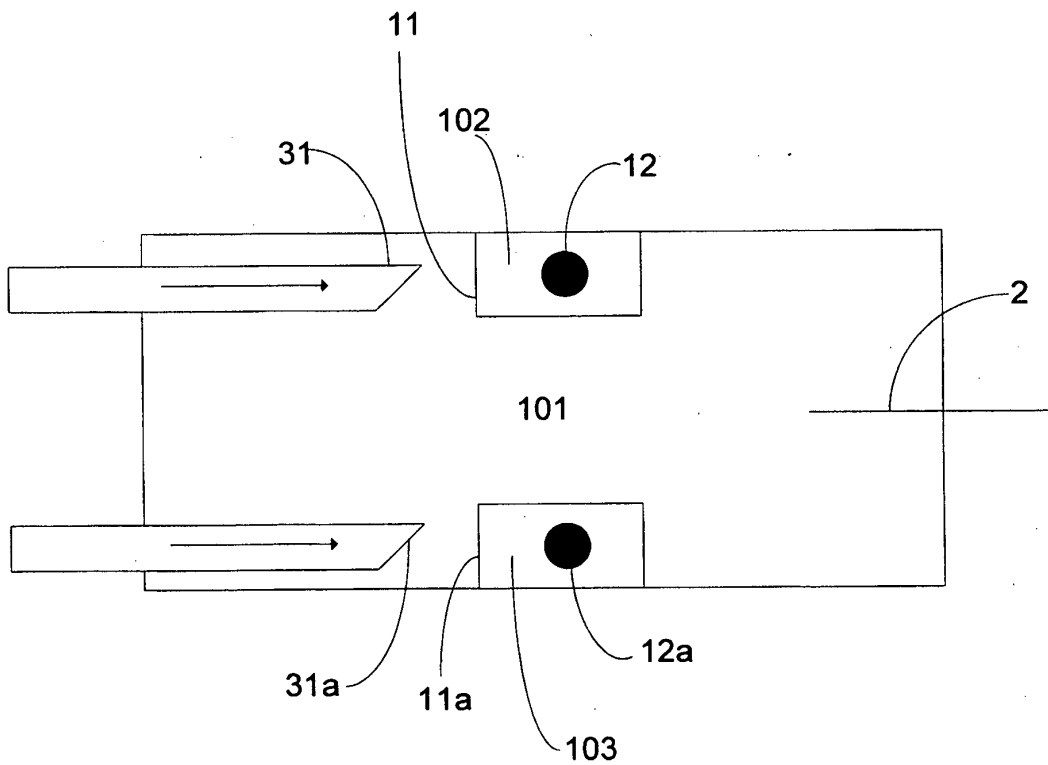

Figure 2

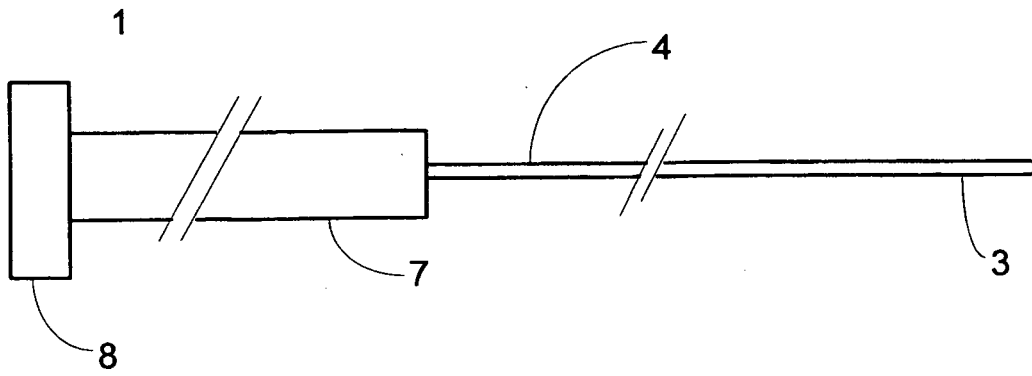

Figure 3

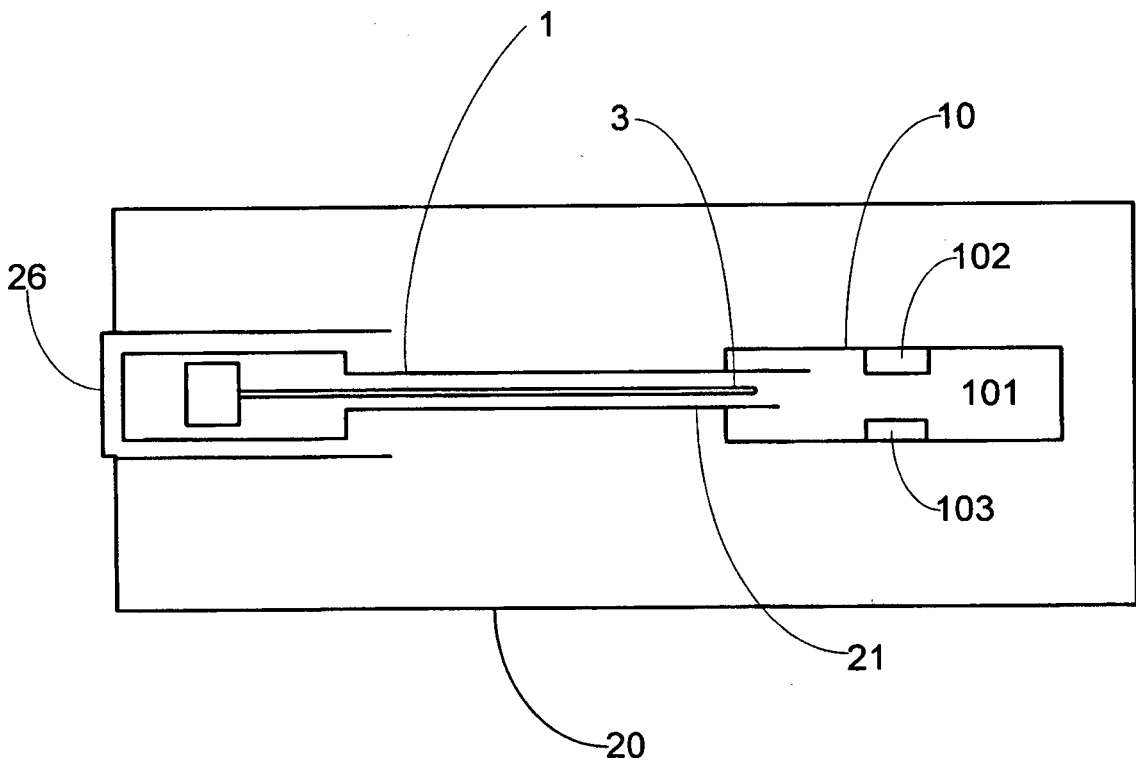

Figure 4

REFERENCES CITED IN THE DESCRIPTION

This list of references cited by the applicant is for the reader's convenience only. It does not form part of the European patent document. Even though great care has been taken in compiling the references, errors or omissions cannot be excluded and the EPO disclaims all liability in this regard.

Patent documents cited in the description

- EP 0560336 A [0006]
- WO 2008001091 A [0023] [0063]
- US 6387672 B [0056]
- US 20090018418 A [0058]
- US 2009018426 A [0063]

Non-patent literature cited in the description

- **WHISTLER ; BUCHANAN.** Preparation of α -glucose.
The Journal of Biological Chemistry, 1938 [0019]

专利名称(译)	葡萄糖传感器校准方法		
公开(公告)号	EP2432894B1	公开(公告)日	2016-01-27
申请号	EP2010725240	申请日	2010-05-17
[标]申请(专利权)人(译)	glysure		
申请(专利权)人(译)	GLYSURE LTD		
当前申请(专利权)人(译)	灯船医药有限		
[标]发明人	CRANE BARRY COLIN PATERSON WILLIAM		
发明人	CRANE, BARRY, COLIN PATERSON, WILLIAM		
IPC分类号	C12Q1/54 A61B5/00 G01N33/487		
优先权	61/213208 2009-05-18 US		
其他公开文献	EP2432894A1		
外部链接	Espacenet		

摘要(译)

一种校准葡萄糖传感器的方法，该方法包括：(a) 通过将水或水溶液与 α 和 β 葡萄糖组合制备第一含葡萄糖的校准溶液， α 和 β 葡萄糖以固体形式提供；(b) 将葡萄糖传感器暴露于所述第一含葡萄糖校准溶液并确定传感器输出；(c) 将葡萄糖传感器暴露于一种或多种另外的校准溶液，所述校准溶液具有彼此不同的葡萄糖浓度和来自所述第一含葡萄糖的校准溶液，并确定所述校准溶液或每种校准溶液的传感器输出；(d) 根据步骤(b)和(c)中收集的传感器输出数据确定校准曲线。