



(11) **EP 2 083 674 B1**

(12) **EUROPEAN PATENT SPECIFICATION**

(45) Date of publication and mention of the grant of the patent:  
**07.03.2018 Bulletin 2018/10**

(51) Int Cl.:  
**A61B 5/00 (2006.01) C12Q 1/00 (2006.01)**  
**G01N 27/49 (2006.01) G01N 33/487 (2006.01)**

(21) Application number: **07844290.2**

(86) International application number:  
**PCT/US2007/081368**

(22) Date of filing: **15.10.2007**

(87) International publication number:  
**WO 2008/051742 (02.05.2008 Gazette 2008/18)**

(54) **TRANSIENT DECAY AMPEROMETRY**  
**NACHWIRKUNGSSTROMMESSUNG**  
**AMPEROMETRIE DE DECROISSANCE TRANSITOIRE**

(84) Designated Contracting States:  
**AT BE BG CH CY CZ DE DK EE ES FI FR GB GR HU IE IS IT LI LT LU LV MC MT NL PL PT RO SE SI SK TR**

(30) Priority: **24.10.2006 US 854060 P**  
**11.12.2006 US 869557 P**  
**12.12.2006 US 869625 P**

(43) Date of publication of application:  
**05.08.2009 Bulletin 2009/32**

(60) Divisional application:  
**13184225.4 / 2 679 150**

(73) Proprietor: **Ascensia Diabetes Care Holdings AG**  
**4052 Basel (CH)**

(72) Inventors:  
• **WU, Huan-Ping**  
**Granger, IN 46530 (US)**

- **CHARLTON, Steven C.**  
**Osceola, IN 46561 (US)**
- **CHU, Amy H.**  
**Elkhart, IN 46514 (US)**
- **EDELBROCK, Andrew J.**  
**Granger, IN 46530 (US)**
- **JUNG, Sung-Kwon**  
**Granger, IN 46530 (US)**
- **HUANG, Dijia**  
**Granger, IN 46530 (US)**

(74) Representative: **Gille Hrabal**  
**Postfach 18 04 09**  
**40571 Düsseldorf (DE)**

(56) References cited:  
**EP-A- 1 593 958 US-A- 5 942 102**  
**US-A- 6 153 069 US-A1- 2003 155 237**  
**US-A1- 2003 159 944 US-A1- 2005 109 637**  
**US-A2- 2007 170 055**

**EP 2 083 674 B1**

Note: Within nine months of the publication of the mention of the grant of the European patent in the European Patent Bulletin, any person may give notice to the European Patent Office of opposition to that patent, in accordance with the Implementing Regulations. Notice of opposition shall not be deemed to have been filed until the opposition fee has been paid. (Art. 99(1) European Patent Convention).

**Description****REFERENCE TO RELATED APPLICATIONS**

5 [0001] This application claims the **priority** of U.S. Provisional Application No. 60/854,060 entitled "Transient Decay Amperometry" filed October 24, 2006, the **priority** of U.S. Provisional Application No. 60/869,557 entitled "Transient Decay Amperometry" filed December 11, 2006, and the **priority** of U.S. Provisional Application No. 60/869,625 entitled "Transient Decay Amperometry" filed December 12, 2006,

**BACKGROUND**

10 [0002] Biosensors provide an analysis of a biological fluid, such as whole blood, urine, or saliva. Typically, a biosensor analyzes a sample of the biological fluid to determine the concentration of one or more analytes, such as alcohol, glucose, uric acid, lactate, cholesterol, or bilirubin, in the biological fluid. The analysis is useful in the diagnosis and treatment of physiological abnormalities. For example, a diabetic individual may use a biosensor to determine the glucose level in whole blood for adjustments to diet and/or medication.

15 [0003] Biosensors may be implemented using bench-top, portable, and like measurement devices. The portable measurement devices may be hand-held. Biosensors may be designed to analyze one or more analytes and may use different volumes of biological fluids. Some biosensors may analyze a single drop of whole blood, such as from 0.25-15 microliters ( $\mu\text{L}$ ) in volume. Examples of portable measurement devices include the Ascensia Breeze® and Elite® meters of Bayer Corporation; the Precision® biosensors available from Abbott in Abbott Park, Illinois; Accucheck® biosensors available from Roche in Indianapolis, Indiana; and OneTouch Ultra® biosensors available from Lifescan in Milpitas, California. Examples of bench-top measurement devices include the BAS 100B Analyzer available from BAS Instruments in West Lafayette, Indiana; the Electrochemical Workstation available from CH Instruments in Austin, Texas; another Electrochemical Workstation available from Cypress Systems in Lawrence, Kansas; and the EG&G Electrochemical Instrument available from Princeton Research Instruments in Princeton, New Jersey.

20 [0004] Biosensors usually measure an electrical signal to determine the analyte concentration in a sample of the biological fluid. The analyte typically undergoes an oxidation/reduction or redox reaction when an input signal is applied to the sample. An enzyme or similar species may be added to the sample to enhance the redox reaction. The input signal usually is an electrical signal, such as a current or potential. The redox reaction generates an output signal in response to the input signal. The output signal usually is an electrical signal, such as a current or potential, which may be measured and correlated with the concentration of the analyte in the biological fluid.

25 [0005] Many biosensors include a measurement device and a sensor strip. The sensor strip may be adapted for use outside, inside, or partially inside a living organism. When used outside a living organism, a sample of the biological fluid is introduced into a sample reservoir in the sensor strip. The sensor strip may be placed in the measurement device before, after, or during the introduction of the sample for analysis. When inside or partially inside a living organism, the sensor strip may be continually immersed in the sample or the sample may be intermittently introduced to the strip. The sensor strip may include a reservoir that partially isolates a volume of the sample or be open to the sample. Similarly, the sample may continuously flow through the strip or be interrupted for analysis.

30 [0006] The measurement device usually has electrical contacts that connect with the electrical conductors of the sensor strip. The electrical conductors typically connect to working, counter, and/or other electrodes that extend into the sample reservoir. The measurement device applies the input signal through the electrical contacts to the electrical conductors of the sensor strip. The electrical conductors convey the input signal through the electrodes into the sample present in the sample reservoir. The redox reaction of the analyte generates an output signal in response to the input signal. The measurement device determines the analyte concentration in response to the output signal.

35 [0007] The sensor strip may include reagents that react with the analyte in the sample of biological fluid. The reagents may include an ionizing agent to facilitate the redox reaction of the analyte, as well as mediators or other substances that assist in transferring electrons between the analyte and the conductor. The ionizing agent may be an oxidoreductase, such as an analyte specific enzyme, which catalyzes the oxidation of glucose in a whole blood sample. The reagents may include a binder that holds the enzyme and mediator together.

40 [0008] Many biosensors use amperometric methods where an electrical signal of constant potential (voltage) is applied to the electrical conductors of the sensor strip while the measured output signal is a current. Thus, in an amperometric system current may be measured as a constant potential is applied across the working and counter electrodes of the sensor strip. The measured current then may be used to determine the presence of and/or quantify the analyte in the sample. Amperometry measures the rate at which the measurable species, and thus the analyte, is being oxidized or reduced at the working electrode. In addition to analytes, biological substrates and mediators, for example, may serve as measurable species

**[0009]** As the time during which the input signal is applied to the sensor strip increases, the rate at which the measurable species is oxidized or reduced at the working electrode decreases. Thus, after an initial period of high current output, the current recorded from the sensor strip decreases as the input signal continues to be applied. This current decrease with time may be referred to as an electrochemical decay, and the rate of this decay may be correlated with the concentration of measurable species, and thus the analyte, in the sample. An electrochemical decay may be a transient or Cottrell decay.

**[0010]** The electrochemical decay may be correlated with the analyte concentration in the sample by expressing the decay with an equation describing a line that relates current with time by the natural log function (ln), for example. Thus, the output current may be expressed as a function of time with an exponential coefficient, where negative exponential coefficients indicate a decay process. After the initial decrease in current output, the rate of decrease may remain relatively constant or continue to fluctuate.

**[0011]** U.S. Pat. No. 5,942,102 ("the '102 patent") describes the relationship between measured output current and time during a conventional analysis. An electrical signal is input to a sensor strip about 60 seconds after introduction of the whole blood sample to the strip. Initially, a rapidly decreasing current is observed, which is followed by a relatively constant or "steady-state" current output that is generated by the feedback of mediator from the counter to the working electrode. The feedback of the mediator provided by the short distance between the electrodes results in the current becoming substantially independent of time after the initial decrease. In this conventional analysis, the analyte concentration of the sample may be determined from the concentration and diffusion coefficient of the mediator as determined by: (1) measuring current as a function of time; and then (2) estimating the steady state current.

**[0012]** While the analysis method described in the '102 patent relies on the steady-state portion of the current decay, U.S. Pat. Nos. 6,153,069 ("the '069 patent") and 6,413,411 ("the '411 patent") describe methods where the concentration of a mediator, and thus the underlying analyte, is determined from the diffusion coefficient of the mediator. These systems are configured to provide a rate of current decay that is described by the Cottrell equation.

**[0013]** Current measurements demonstrate Cottrell decay when the measured current is inversely proportional to the square root of time. Current measurements with Cottrell decay may be described by the Cottrell equation given below as Equation (1):

$$i(t) = nFAC^b \left( \frac{D}{\pi t} \right)^{1/2} = nFAC^b \left( \frac{D}{\pi} \right)^{1/2} t^{-0.5} \quad (1),$$

where  $i$  is the measured current;  $C^b$  is the bulk concentration of the electrochemically active species in mol/cm<sup>3</sup>;  $A$  is the electrode area in cm<sup>2</sup>;  $F$  is the Faraday constant of 96,500 coul/equivalent;  $n$  is the number of electrons transferred in equivalents/mol.;  $D$  is the diffusion coefficient in cm<sup>2</sup>/sec; and  $t$  is the time of the electrochemical reaction in seconds. Thus, the Cottrell equation describes current as an exponential function of time, having a decay constant or exponential coefficient of -0.5. Further details of the Cottrell equation and the boundary conditions required for Cottrell behavior may be found in chapter 5, pp. 136-45, of *Electrochemical Methods: Fundamentals and Applications* by Bard and Faulkner (1980).

**[0014]** A system designed to operate with a Cottrell current decay requires a decay constant of -0.5. An electrochemical system demonstrating a -0.5 decay constant implies that the requirements of a Cottrell current are present, namely that the analyte has completely converted to a measurable species and that a substantially constant concentration distribution of this measurable species occupies the sample reservoir before current measurement. These requirements are further described in the '069 and '411 patents.

**[0015]** Column 4, Lines 39-40 of the '411 patent discloses that initial incubation periods of 15 to 90 seconds, preferably from 20 to 45 seconds, are used for glucose testing. After the initial incubation period and application of a single excitation input signal, current measurements demonstrating Cottrell decay may be recorded from 2 to 30 seconds or preferably from 10 to 20 seconds following application of the input signal to the sensor strip. The requirement of a longer initial incubation period also is depicted in FIG. 7 of the '411 patent, where the sample was allowed to react in the sensor strip (incubate) for 160 seconds before application of the input signal.

**[0016]** The longer incubation periods required to completely convert the analyte to measurable species provide: (1) time for hydration of the reagent layer containing the reagents; and (2) time for the reagents to convert the analyte. For example, column 4, lines 36-44 of the '411 patent describes an incubation period of sufficient length to allow the enzymatic reaction to reach completion. After this incubation period, where the glucose analyte is fully converted to a measurable species, the instrument imposes a known potential across the electrodes to measure the resulting diffusion limited (i.e. Cottrell) current at specific times during the resulting Cottrell current decay. Thus, the conversion of the analyte to the measurable species is completed before Cottrell decay is observed. Complete hydration of the reagent layer also is recognized in the '411 patent as a requirement for Cottrell decay. The '411 patent discloses that incomplete wetting of

the reagent results in a failure of the system to follow the Cottrell curve decay, which results in an inaccurate analyte concentration value being obtained.

[0017] In addition to an extended incubation period, Cottrell decay also requires a substantially constant concentration distribution of a measurable species in the sample as the distance from the electrode surface increases. A substantially constant concentration distribution may be achieved with: (1) relatively large sample volumes; and/or (2) a relatively large distance between facing planar electrodes or substantially planar electrodes and the bottom surface of the sensor strip lid. For example, column 8, line 40 of the '069 patent describes a working electrode occupying a sample reservoir providing a 50  $\mu\text{L}$  sample volume where the vertical distance between the working electrode and the lid is from 500-2000  $\mu\text{m}$ . In another example, unlike the closely spaced electrodes of the '102 patent, the distance between the working and counter electrodes described in column 7, lines 62-66 of the '411 patent must be at least 100 microns, and preferably greater than 100 microns.

[0018] Conventional analysis methods typically lengthen the time required to analyze samples by requiring incubation periods, electrode distances, and sample reservoir volumes sufficient to allow the system to have Cottrell decay. Accordingly, there is an ongoing need for improved biosensors; especially those that more quickly determine the analyte concentration of a sample and do not rely on the estimation of a steady state current value. The systems, devices, and methods of the present invention overcome at least one of the disadvantages associated with conventional biosensors.

[0019] Some other Electrochemical apparatus for glucose testing can be seen in patent documents US 2003/0159944 A1, US 2003/0155237 A1, and US 2005/0109637A1.

## SUMMARY

[0020] The present invention provides a biosensor system that determines an analyte concentration of a biological sample from an output signal having a transient decay. The output signal is not inversely proportional to the square root of the time, and thus has a decay constant greater or less than the decay constant of a Cottrell decay.

[0021] A method for determining an analyte concentration in a sample is provided according to the claim 1.

[0022] Some advantageous embodiments are described in claims 2 to 15.

## BRIEF DESCRIPTION OF THE DRAWINGS

[0023] The invention can be better understood with reference to the following drawings and description. The components in the figures are not necessarily to scale, emphasis instead being placed upon illustrating the principles of the invention.

FIG. 1A is a perspective representation of an assembled sensor strip.

FIG. 1B is a top-view diagram of a sensor strip, with the lid removed.

FIG. 2A is an end view diagram of the sensor strip of FIG. 1B.

FIG. 2B depicts a schematic representation of a biosensor system that determines an analyte concentration in a sample.

FIG. 3 represents a flowchart of an electrochemical method for determining the presence and/or concentration of an analyte in a sample.

FIG. 4A represents a sample reservoir bounded by a lower electrode surface and an upper lid.

FIG. 4B represents concentration profiles formed from the sensor system when incubation times  $t_1$  through  $t_5$  pass before application of an input signal.

FIG. 4C represents the relation between measurable species concentrations in the reservoir and rates of current decay.

FIG. 5 depicts decay rates obtained from working electrodes after varying incubation periods for whole blood samples containing 50, 100, 200, or 400 mg/dL of glucose.

FIGs. 6A-6C plot the current profiles obtained from three sensor strips each having a different average initial thickness of the reaction layer at multiple initial incubation periods.

## EP 2 083 674 B1

FIGs. 7A-7B plot the natural logs of current vs. time for whole blood samples including 100 or 300 mg/dL of glucose at 40% hematocrit obtained after a 6 second initial incubation period.

FIGs. 8A-8C are current decay profiles from a 0.25 second incubation period followed by a gated input signal having excitation times of 0.5 second and relaxation times of 0.25 second.

FIG. 8D is a calibration plot obtained by plotting the endpoint currents ( $p_1$ ,  $p_2$ ,  $p_3$ ) of the first three excitations obtained from thin reagent layer sensor strips as depicted in FIGs. 8A-8C.

FIG. 8E is a calibration plot obtained by plotting the endpoint currents ( $p_4$ ,  $p_5$ ,  $p_6$ ) of excitations 4, 5, and 6 obtained from sensor strips having intermediate thickness reagent layers as depicted in FIGs. 8A-8C.

### DETAILED DESCRIPTION

**[0024]** A biosensor system uses an electrochemical process lacking a Cottrell decay constant to determine an analyte concentration of a biological sample. The biosensor system generates an output signal from the biological sample having a transient decay, where the output signal is not inversely related to the square root of the time. The transient decay output from the biosensor system has a decay constant greater or less than -0.5 and the system does not rely on an estimation of a steady state current value to determine the analyte concentration. Preferably, transient decays from which analyte concentrations are determined continually decrease.

**[0025]** Cottrell decay is diffusion dependent and may not exist unless the analyte has completely converted to a measurable species and a substantially constant concentration distribution of this measurable species occupies the sample reservoir before current measurement. Relatively long incubation times and large sample volumes are required to obtain Cottrell decay. Without these conditions, the output current will not be inversely related to the square root of time and thus biosensors will not exhibit the -0.5 decay constant required for Cottrell decay. Biosensors designed to operate with Cottrell decay will provide inaccurate analyses if the output current is not inversely related to the square root of time or if a decay constant other than -0.5 is present in the output signal.

**[0026]** The present biosensor system operates using transient decays, where decay constants smaller or larger than -0.5 are observed. The transient and thus non-Cottrell decay constants may result from a relatively short incubation period. Transient decay constants also may result from relatively small sample reservoir volumes, relatively small distances between electrode surfaces and the lid of the sensor strip, and/or relatively short excitations in relation to the average initial thickness of the reagent layer.

**[0027]** To generate an output current with a transient decay or transient decay constants greater or less than -0.5, the biosensor system may use incubation periods of 12 seconds or less, reservoir volumes of 5  $\mu\text{L}$  or less, reservoir heights of 200  $\mu\text{m}$  or less, and/or an average initial thickness for the reagent layer of 20  $\mu\text{m}$  or less. Preferable incubation periods for use with reservoir volumes of 3.5  $\mu\text{L}$  or less, reservoir heights of 150  $\mu\text{m}$  or less, and/or an average initial thickness for the reagent layer of 10  $\mu\text{m}$  or less are at most 8 seconds, at most 6 seconds, or at most 4 seconds. At present, especially preferred incubation periods for use with sample strip sample volumes of 3.0  $\mu\text{L}$  or less, sample strip cap-gap heights of 100  $\mu\text{m}$  or less, and/or an average initial thickness for the reagent layer of 2  $\mu\text{m}$  or less are at most 2 seconds or at most 1 second. Other incubation periods, reservoir volumes, reservoir heights, and reagent layer thicknesses may be used.

**[0028]** FIGs. 1A and 1B depict a sensor strip **100**, which may be used with the biosensor system. FIG. 1A is a perspective view of an assembled sensor strip **100** including a sensor base **110**, at least partially covered by a lid **120** that includes a vent **130**, a sample coverage area **140**, and an input end opening **150**. A partially-enclosed sample reservoir **160** (the capillary gap or cap-gap) is formed between the base **110** and the lid **120**. Other sensor strip designs also may be used, such as those described in U.S. Patent Nos. 5,120,420 and 5,798,031. While a particular configuration is shown in FIGs. 1A-1B, the sensor strip **100** may have other configurations, including those with additional components.

**[0029]** The height of the reservoir **160** between the sensor base **110** and the lid **120** may be from 20 to 250 micrometers ( $\mu\text{m}$ ), more preferably from 50 to 150  $\mu\text{m}$ . The volume of the reservoir **160** may be from 0.25 to 10  $\mu\text{L}$ , preferably from 0.8 to 4  $\mu\text{L}$ , and more preferably from 0.5 to 1.5  $\mu\text{L}$ . Other heights and volumes may be used.

**[0030]** A liquid sample for analysis may be transferred into the reservoir **160** by introducing the liquid to the opening **150**. The liquid fills the reservoir **160** while expelling the previously contained air through the vent **130**. The reservoir **160** may contain a composition (not shown) that assists in retaining the liquid sample in the reservoir. Examples of such compositions include: water-swellable polymers, such as carboxymethyl cellulose and polyethylene glycol; and porous polymer matrices, such as dextran and polyacrylamide.

**[0031]** FIG. 1B depicts a top-view of the sensor strip **100**, with the lid **120** removed. Conductors **170** and **180** may run under a dielectric layer **190** from the opening **150** to a working electrode **175** and a counter electrode **185**, respectively. The sensor strip **100** may include more than one working electrode. The working and counter electrodes **175**, **185** may

be in substantially the same plane. The electrodes may be in another orientation. The dielectric layer **190** may partially cover the electrodes **175**, **185** and may be made from any suitable dielectric material, such as an insulating polymer. While a particular electrode configuration is shown, the electrodes may have other configurations, including those with additional components.

**[0032]** The counter electrode **185** may support the electrochemical activity at the working electrode **175** of the sensor strip **100**. The potential to support the electrochemical activity at the working electrode **175** may be provided to the sensor system by forming the counter electrode **185** from an inert material, such as carbon, and including a soluble redox species, such as ferricyanide, within the reservoir **160**. The potential at the counter electrode **185** may be a reference potential achieved by forming the counter electrode **185** from a redox pair, such as Ag/AgCl, to provide a combined reference-counter electrode. A redox pair includes two conjugate species of a chemical substance having different oxidation numbers. Reduction of the species having the higher oxidation number produces the species having the lower oxidation number. Alternatively, oxidation of the species having the lower oxidation number produces the species having the higher oxidation number. The sensor strip **100** may be provided with a third conductor and electrode to provide a reference potential to the sensor system.

**[0033]** The working and counter electrodes **175**, **185** may be separated by greater than 200  $\mu\text{m}$  or 250  $\mu\text{m}$ . The working and counter electrodes **175**, **185** may be separated by less than 200  $\mu\text{m}$ . The working and counter electrodes **175**, **185** may be separated by other distances.

**[0034]** FIG. 2A depicts an end view of the sensor strip **100** depicted in FIG. 1B, showing the layer structure of the working electrode **175** and the counter electrode **185** residing within the reservoir **160**. The conductors **170** and **180** may lie on the base **110**. Other materials may reside between the conductors **170**, **180** and the base **110**, thus the conductors may or may not be in physical contact with the base. A portion of the conductors may penetrate a portion of the base. Surface conductor layers **270** and **280** optionally may be deposited on the conductors **170** and **180**, respectively. Other materials may reside between the surface conductor layers **270**, **280** and the conductors **170**, **180**, thus the surface conductors may or may not be in physical contact with the conductors. A portion of the surface conductors may penetrate a portion of the conductors. The surface conductor layers **270**, **280** may be made from the same or from different materials.

**[0035]** The material or materials forming the conductors **170**, **180** and the surface conductor layers **270**, **280** may include any electrical conductor. The conductors **170**, **180** preferably include a thin layer of a metal paste or metal, such as gold, silver, platinum, palladium, copper, or tungsten. The surface conductor layers **270**, **280** preferably include carbon, gold, platinum, palladium, or combinations thereof. Preferable electrical conductors are non-ionizing, such that the material does not undergo a net oxidation or a net reduction during analysis of the sample. Thus, if a surface conductor layer is not on a conductor, the conductor is preferably made from a non-ionizing material, such as carbon, gold, platinum, palladium, or combinations thereof.

**[0036]** The surface conductor material may be deposited on the conductors **170**, **180** by any conventional means compatible with the operation of the sensor strip, including foil deposition, chemical vapor deposition, slurry deposition, and the like. In the case of slurry deposition, the conductor material may be applied as an ink to the conductors **170**, **180**, as described in U.S. Pat. No. 5,798,031.

**[0037]** The reagent layers **275** and **285** may be deposited on the conductors **170** and **180**, respectively. The layers are formed from at least one reagent composition that may include a binder. The binder is preferably a polymeric material that is at least partially water-soluble. The binder may form a gel or gel-like material when hydrated. The binder may form a gel or gel-like material in combination with the reagents when hydrated. The gel or gel-like material may inhibit and/or filter red blood cells from reaching the surface conductor **270** and/or the conductor **170**.

**[0038]** Suitable partially water-soluble polymeric materials for use as the binder may include poly(ethylene oxide) (PEO), carboxy methyl cellulose (CMC), polyvinyl alcohol (PVA), hydroxyethylene cellulose (HEC), hydroxypropyl cellulose (HPC), methyl cellulose, ethyl cellulose, ethyl hydroxyethyl cellulose, carboxymethyl ethyl cellulose, polyvinyl pyrrolidone (PVP), polyamino acids, such as polylysine, polystyrene sulfonate, gelatin, acrylic acid, methacrylic acid, starch, maleic anhydride salts thereof, derivatives thereof, and combinations thereof. Among the above binder materials, PEO, PVA, CMC, and HEC are preferred, with CMC being more preferred at present.

**[0039]** In addition to the binder, the reagent layers **275** and **285** may include the same or different reagents. When including the same reagents, the reagent layers **275** and **285** may be the same layer. In one aspect, the reagents present in the first layer **275** may be selected for use with the working electrode **175**, while the reagents present in the second layer **285** may be selected for use with the counter electrode **185**. For example, the reagents in the layer **285** may facilitate the flow of electrons between the sample and the conductor **180**. Similarly, the reagents in the layer **275** may facilitate the reaction of the analyte.

**[0040]** The reagent layer **275** may include an enzyme system specific to the analyte that may enhance the specificity of the sensor system to the analyte, especially in complex biological samples. The enzyme system may include one or more enzyme, cofactor, and/or other moiety that participates in the redox reaction of the analyte. For example, an alcohol oxidase can be used to provide a sensor strip that is sensitive to the presence of alcohol in a sample. Such a system may be useful in measuring blood alcohol concentrations. In another example, glucose dehydrogenase or glucose

oxidase may be used to provide a sensor strip that is sensitive to the presence of glucose in a sample. This system may be useful in measuring blood glucose concentrations, for example in patients known or suspected to have diabetes.

**[0041]** Enzymes for use in the enzyme system include alcohol dehydrogenase, lactate dehydrogenase,  $\beta$ -hydroxybutyrate dehydrogenase, glucose-6-phosphate dehydrogenase, glucose dehydrogenase, formaldehyde dehydrogenase, malate dehydrogenase, and 3-hydroxysteroid dehydrogenase. Preferable enzyme systems may be oxygen independent, thus not substantially oxidized by oxygen.

**[0042]** One such oxygen independent enzyme family for use in a glucose sensor strip is glucose dehydrogenase (GDH). Using different coenzymes or co-factors, GDH may be mediated in a different manner by different mediators. Depending on the association with GDH, a co-factor, such as flavin adenine dinucleotide (FAD), can be tightly held by the host enzyme, such as in the case of FAD-GDH; or a co-factor, such as Pyrroloquinolinequinone (PQQ), may be covalently linked to the host enzyme, such as with PQQ-GDH. The co-factor in each of these enzyme systems may be held by the host enzyme, or the co-enzyme and the apo-enzyme may be re-constituted before the enzyme system is added to the reagent composition. The co-enzyme also may be independently added to the host enzyme in the reagent composition to assist in the catalytic function of the host enzyme, such as in the cases of nicotinamide adenine dinucleotide NAD/NADH<sup>+</sup> or nicotinamide adenine dinucleotide phosphate NADP/NADPH<sup>+</sup>.

**[0043]** The reagent layer **275** also may include a mediator to more effectively communicate the results of the analyte redox reaction to the surface conductor **270** and/or the conductor **170**. Mediators may be separated into two groups based on their electrochemical activity. One electron transfer mediators are capable of taking on one additional electron during electrochemical reactions. Examples of one electron transfer mediators include compounds, such as 1,1'-dimethyl ferrocene, ferrocyanide and ferricyanide, and ruthenium(III) hexamine. Two electron transfer mediators are capable of taking on two additional electrons.

**[0044]** Two electron mediators include the organic quinones and hydroquinones, such as phenanthroline quinone; phenothiazine and phenoxazine derivatives; 3-(phenylamino)-3H-phenoxazines; phenothiazines; and 7-hydroxy-9,9-dimethyl-9H-acridin-2-one and its derivatives. Examples of additional two electron mediators include the electroactive organic molecules described in U.S. Pat. Nos. 5,393,615; 5,498,542; and 5,520,786, which are incorporated herein by reference. Other electroactive organic molecules include organic molecules lacking a metal that are capable of undergoing a redox reaction. Electroactive organic molecules can behave as redox species and/or as mediators. Examples of electroactive organic molecules include coenzyme pyrroloquinoline quinone (PQQ), benzoquinones and naphthoquinones, N-oxides, nitroso compounds, hydroxylamines, oxines, flavins, phenazines, phenothiazines, indophenols, and indamines.

**[0045]** Preferred two electron transfer mediators include 3-phenylimino-3H-phenothiazines (PIPT) and 3-phenylimino-3H-phenoxazines (PIPO). More preferred two electron mediators include the carboxylic acid or salt, such as ammonium salts, of phenothiazine derivatives. At present, especially preferred two electron mediators include (E)-2-(3H-phenothiazine-3-ylideneamino)benzene-1,4-disulfonic acid, (E)-5-(3H-phenothiazine-3-ylideneamino)isophthalic acid, ammonium (E)-3-(3H-phenothiazine-3-ylideneamino)-5-carboxybenzoate, and combinations thereof. Preferred two electron mediators may have a redox potential that is at least 100 mV lower, more preferably at least 150 mV lower, than ferricyanide.

**[0046]** The reagent layers **275**, **285** may be deposited by any convenient means, such as printing, liquid deposition, or ink-jet deposition. In one aspect, the layers are deposited by printing. With other factors being equal, the angle of the printing blade may inversely affect the initial thickness of the reagent layer. For example, when the blade is moved at an approximately 82° angle to the base **110**, the layer may have an initial thickness of approximately 10  $\mu\text{m}$ . Similarly, when a blade angle of approximately 62° to the base **110** is used, a thicker 30  $\mu\text{m}$  layer may be produced. Thus, lower blade angles may provide thicker reagent layers. In addition to blade angle, other factors, such as the viscosity of the reagent composition as well as the screen-size and emulsion combination, may affect the resulting thickness of the reagent layers **275**, **285**.

**[0047]** When thinner reagent layers are preferred, deposition methods other than printing, such as micro-pipetting, ink jetting, or pin-deposition, may be used. These deposition methods generally give the dry reagent layers at micrometer or sub-micrometer thickness, such as 1-2  $\mu\text{m}$ . For example, pin-deposition methods may provide an average initial thickness of about 1  $\mu\text{m}$  for the reagent layer. The thickness of the reagent layer resulting from pin-deposition, for example, may be controlled by the amount of polymer included in the reagent composition, with higher polymer content providing thicker reagent layers. Thinner reagent layers may require shorter excitation durations than thicker reagent layers to maintain the desired measurement performance and/or substantially measure analyte within the diffusion barrier layer (DBL).

**[0048]** The working electrode **175** may include a DBL that is integral to a reagent layer **275** or that is a distinct layer **290**, such as depicted in FIG. 2A. Thus, the DBL may be formed as a combination reagent/DBL on the conductor, as a distinct layer on the conductor, or as a distinct layer on the reagent layer. When the working electrode **175** includes the distinct DBL **290**, the reagent layer **275** may or may not reside on the DBL **290**. Instead, the reagent layer **275** may reside on any portion of the sensor strip **100** that allows the reagent to solubilize in the sample. For example, the reagent layer **175** may reside on the base **110** or on the lid **120**.

**[0049]** The DBL provides a porous space having an internal volume where a measurable species may reside and also

may filter red blood cells from the conductor surface. The pores of the DBL may be selected so that the measurable species may diffuse into the DBL, while physically larger sample constituents, such as red blood cells, are substantially excluded. Although conventional sensor strips have used various materials to filter red blood cells from the surface of the working electrode, a DBL provides an internal porous space to contain and isolate a portion of the measurable species from the sample.

**[0050]** When the reagent layer **275** includes a water-soluble binder, any portion of the binder that does not solubilize into the sample prior to the application of an excitation may function as an integral DBL. The average initial thickness of a combination DBL/reagent layer is preferably less than 20 or 10  $\mu\text{m}$  and more preferably less than 5  $\mu\text{m}$ . The desired average initial thickness of a combination DBL/reagent layer may be selected for a specific excitation length on the basis of when the diffusion rate of the measurable species from the DBL to a conductor surface, such as the surface of the conductor **170** or the surface of the surface conductor **270** from FIG. 2A, becomes relatively constant. The combination DBL/reagent layer may have an average initial thickness of 2  $\mu\text{m}$ , 1  $\mu\text{m}$ , or less when combined with an excitation duration of 0.25 seconds or less.

**[0051]** The distinct DBL **290** may include any material that provides the desired pore space, while being partially or slowly soluble in the sample. The distinct DBL **290** may include a reagent binder material lacking reagents. The distinct DBL **290** may have an average initial thickness from 1 to 15  $\mu\text{m}$ , and more preferably from 2 to 5  $\mu\text{m}$ .

**[0052]** FIG. 2B depicts a schematic representation of a biosensor system **200** that determines an analyte concentration in a sample, such as a biological fluid. The biosensor system **200** includes a measurement device **202** that performs an analysis method and a sensor strip **204**. The sensor strip **204** may be an electrochemical sensor strip as depicted in FIGs. 1A, 1B, and 2A, for example. The measurement device **202** may be implemented as a bench-top device, a portable or hand-held device, or the like.

The measurement device **202** and the sensor strip **204** may implement an electrochemical analysis, an optical analysis, a combination thereof, or the like. The biosensor system **200** may determine analyte concentrations, including those of alcohol, glucose, uric acid, lactate, cholesterol, bilirubin, and the like in biological samples. While a particular configuration is shown, the biosensor system **200** may have other configurations, including those with additional components.

**[0053]** The sensor strip **204** has a base **206** that forms a sample reservoir **208** and a channel **210** with an opening **212**. Referring to FIG. 1A, the channel **210** may be integral to the reservoir **208**. The reservoir **208** and the channel **210** may be covered by a lid with a vent. The reservoir **208** defines a partially-enclosed volume (the cap-gap). The reservoir **208** may contain a composition that assists in retaining a liquid sample, such as water-swellable polymers or porous polymer matrices. Reagents may be deposited in the reservoir **208** and/or channel **210**. The reagent composition may include one or more enzymes, binders, mediators, and the like. The reagents may include a chemical indicator for an optical system. The sensor strip **204** may have other configurations.

**[0054]** The sensor strip **204** also may have a sample interface **214**. In an electrochemical system, the sample interface **214** has conductors connected to at least two electrodes, such as a working electrode and a counter electrode. The electrodes may be disposed on a surface of the base **206** that forms the reservoir **208**. The sample interface **214** may have other electrodes and/or conductors.

**[0055]** The measurement device **202** includes electrical circuitry **216** connected to a sensor interface **218** and a display **220**. The electrical circuitry **216** may include a processor **222** connected to a signal generator **224**, an optional temperature sensor **226**, and a storage medium **228**. The electrical circuitry **216** may have other configurations including those with additional components.

**[0056]** The signal generator **224** provides an electrical input signal to the sensor interface **218** in response to the processor **222**. In optical systems, the electrical input signal may be used to operate or control the detector and light source in the sensor interface **218**. In electrochemical systems, the electrical input signal may be transmitted by the sensor interface **218** to the sample interface **214** to apply the electrical input signal to the reservoir **208** and thus, to the sample.

**[0057]** The electrical input signal may be a potential or current and may be constant, variable, or a combination thereof, such as when an AC signal is applied with a DC signal offset. The electrical input signal may be applied as a single pulse or in multiple pulses, sequences, or cycles. The signal generator **224** also may record an output signal from the sensor interface **218** as a generator-recorder.

**[0058]** The storage medium **228** may be a magnetic, optical, or semiconductor memory, another computer readable storage device, or the like. The storage medium **228** may be a fixed memory device or a removable memory device such as a memory card.

**[0059]** The processor **222** may implement analyte analysis and data treatment using computer readable software code and data stored in the storage medium **228**. The processor **222** may start the analyte analysis in response to the presence of the sensor strip **204** at the sensor interface **218**, the application of a sample to the sensor strip **204**, in response to user input, or the like. The processor **222** may direct the signal generator **224** to provide the electrical input signal to the sensor interface **218**. The processor **222** may receive the sample temperature from the temperature sensor **226**, if so equipped.

**[0060]** The processor **222** receives the output signal from the sensor interface **218**. The output signal is generated in response to the redox reaction of the analyte in the sample. The output signal may be generated using an optical system, an electrochemical system, or the like.

The processor **222** may determine the concentration of the analyte in the sample from one or more output signals using a correlation equation. The results of the analyte analysis are output to the display **220** and may be stored in the storage medium **228**.

**[0061]** The correlation equations relating analyte concentrations and output signals may be represented graphically, mathematically, a combination thereof, or the like. The correlation equations may be represented by a program number assignment (PNA) table, another look-up table, or the like that is stored in the storage medium **228**. Instructions regarding implementation of the analysis may be provided by the computer readable software code stored in the storage medium **228**. The code may be object code or any other code describing or controlling the functionality described herein. The data from the analyte analysis may be subjected to one or more data treatments, including the determination of decay rates, K constants, slopes, intercepts, and/or sample temperature in the processor **222**.

**[0062]** In electrochemical systems, the sensor interface **218** is in electrical or optical communication with the sample interface **214**. Electrical communication includes the transfer of input and/or output signals between contacts in the sensor interface **218** and conductors in the sample interface **214**. Electrical communication may be implemented wirelessly or through physical contact, for example. The sensor interface **218** transmits the electrical input signal from the signal generator **224** through the contacts to the connectors in the sample interface **214**. The sensor interface **218** also transmits the output signal from the sample through the contacts to the processor **222** and/or the signal generator **224**.

**[0063]** Optical communication includes the transfer of light between an optical portal in the sample interface **202** and a detector in the sensor interface **208**. Optical communication also includes the transfer of light between an optical portal in the sample interface **202** and a light source in the sensor interface **208**.

**[0064]** The display **220** may be analog or digital. The display **220** may be a LCD, LED, or vacuum fluorescent display adapted to displaying a numerical reading.

**[0065]** In use, a liquid sample for analysis is transferred into the reservoir **208** by introducing the liquid to the opening **212**. The liquid sample flows through the channel **210** and into the reservoir **208**, while expelling the previously contained air. The liquid sample chemically reacts with the reagents deposited in the channel **210** and/or the reservoir **208**. The processor **222** directs the signal generator **224** to provide an input signal to the sensor interface **218**. In an optical system, the sensor interface **218** operates the detector and light source in response to the input signal. In an electrochemical system, the sensor interface **218** provides the input signal to the sample through the sample interface **214**. The processor **222** receives the output signal generated in response to the redox reaction of the analyte in the sample. The processor **222** determines the analyte concentration of the sample using one or more correlation equations. The determined analyte concentration may be displayed and/or stored for future reference.

**[0066]** FIG. 3 represents a flowchart of an electrochemical analysis **300** for determining the presence and optionally the concentration of an analyte **322** in a sample **312**. In **310**, the sample **312** is introduced to a sensor strip **314**, such as the sensor strip depicted in FIGs. 1A-1B and 2A. The reagent layers, such as **275** and/or **285** depicted in FIG. 2A, begin to solubilize into the sample **312**, thus allowing reaction.

**[0067]** In **315**, an initial incubation period **317** allows the reagents to react with the sample **312** before an input signal is applied. Preferably, the incubation period **317** may be from 0.1 to 10 seconds, more preferably from 0.1 to 8 seconds or from 0.5 to 4 seconds. At present, from 0.1 to 1 second is more preferred for the incubation period **317**. Other incubation periods may be used.

**[0068]** During the incubation period **317**, a portion of the analyte **322** present in the sample **312** is chemically or biochemically oxidized or reduced in **320** by way of a redox reaction to form a measurable species **332**. The measurable species **332** may be the oxidized or reduced analyte **322** or a mediator. Upon oxidation or reduction, electrons may be transferred to or from the analyte **322** and to or from measurable species **332** in **330**. For example, a mediator may be reduced to form the measurable species **332** through oxidation of the analyte **322**. Preferably, the measurable species **332** formed during the incubation period **317** is not electrochemically excited during the incubation period **317**.

**[0069]** In **340**, the measurable species **332** is electrochemically excited (oxidized or reduced). In this manner, electrons are selectively transferred between the analyte **322** and the working electrode of the sensor strip **314**. The excitation **340** may be from 0.1 to 5 seconds or from 0.1 to 1 second in duration. The excitation **340** may be repeated.

**[0070]** In **350**, the current produced during the excitation **340** may be recorded as a function of time. If multiple excitations **340** are applied to the sensor strip **314**, one or more of the currents resulting from the excitations **340** may be recorded in **350**. The currents may be recorded by a measurement device.

**[0071]** In **360**, the sample undergoes relaxation. Preferably, current is not recorded during the relaxation **360**. The relaxation **360** may follow each of the excitations **340** when multiple excitations are applied. During the relaxation **360**, the current present during the excitation **340** is substantially reduced by at least one-half, preferably by an order of magnitude, and more preferably to zero. Preferably, a zero current state is provided by an open circuit or other method known to those of ordinary skill in the art to provide a substantially zero current flow. The measurement device may

open the circuit through the sensor strip **314** to provide the open circuit. If a zero current state is provided, the relaxation **360** may be considered an intermittent incubation period.

**[0072]** The relaxation **360** may be at least 0.1 or at least 0.5 seconds in duration. The relaxation **360** may be from 0.1 to 3 seconds, from 0.2 to 2 seconds, or from 0.5 to 1 second in duration. Other relaxation durations may be used.

**[0073]** In **370**, one or more of the recorded current and time values from **350** may be analyzed to determine the presence and/or concentration of the analyte **322** in the sample **312**. Preferably, the analyte concentration is determined from a current measurement taken within 2 seconds or 1 second of the start of the initially applied excitation. More preferably, multiple short excitations are combined with a current measurement taken within 2 seconds, 1 second, or less from the start of the initially applied input signal to determine the analyte concentration of the sample. The recorded current and time values may be correlated to the concentration of the analyte **322** in the sample **312** using one or more correlation equations.

**[0074]** The excitation **340** and the relaxation **360** constitute a single duty cycle. Preferably, the input signal applied to the sensor strip **314** includes at least 2, 4, or 6 duty cycles applied within an independently selected 3, 5, 7, or 9 second time period. Thus, from the initial application of the input signal, the total time required for the excitation **340** and the relaxation **360** portions of the electrochemical analysis **300** may be at most 3, at most 5, at most 7, or at most 9 seconds. The duty cycles may be applied during a 1 to 3 second time period. From 2 to 6 duty cycles may be applied within 8 seconds or less. From 2 to 4 duty cycles may be applied within 3 to 6 seconds. Other time periods may be used.

**[0075]** For continuous monitoring, as may be used with implanted or partially implanted sensors, the duty cycles may be continuously repeated. The energy required to operate the system may be reduced and the service life of the system may be extended in relation to methods lacking relaxations. Furthermore, the application of multiple duty cycles may be separated by longer time periods, such as 5 minutes or more.

**[0076]** Amperometric sensor systems apply a potential (voltage) to the electrodes to excite the measurable species while the current (amperage) is monitored. Conventional amperometric sensor systems may maintain the excitation potential while continuously measuring the current for from 5 to 10 seconds, for example. In contrast to conventional methods, the input signals used in the electrochemical analysis **300** may replace continuous, long-duration excitations with multiple excitations and relaxations of relatively short duration. A more detailed description of multiple excitation and relaxation or "gated" pulse sequences applied as input signals may be found in WO 2007/013915, filed July 19, 2006, entitled "Gated Amperometry."

**[0077]** When the short initial incubation times and/or gated input signals of the present invention are used, transient or non-Cottrell current decays may result. Not relying on a -0.5 Cottrell decay constant to determine the concentration of the analyte **322** in the sample **312** allows for completion of the electrochemical analysis **300** using transient decays within 8 seconds or less, within 4 seconds or less, or more preferably, within 3 seconds or less. The electrochemical analysis **300** may be completed in 2 seconds or less. The electrochemical analysis **300** may be completed in from about 0.5 to about 3 seconds. The electrochemical analysis **300** using transient decays may be complete using other time periods.

**[0078]** FIG. 4A represents a sample reservoir **400** bounded by a lower electrode surface **402** and an upper lid **403**. A virtual upper boundary **405** of the reagent layer also is represented. Thus, the area between the electrode surface **402** and the virtual upper boundary **405** represents the sample contained by the reagent layer. Similarly, the area between the virtual upper boundary **405** and the upper lid **403** represents the sample above the reagent layer. The x-axis represents distance from the electrode surface, while the y-axis represents the sample concentration of measurable species generated from the redox reaction of the analyte. The figure omits the effect of analyte partitioning between a DBL and the liquid sample within the remaining portion of the reservoir **400**.

**[0079]** Concentration profile **410** represents what would be observed immediately after introducing the sample to a strip, while concentration profile **420** represents what would be observed after a relatively long incubation period. The concentration profile **410** represents a transient condition, while the concentration profile **420** represents a Cottrell condition. Multiple transient states may exist between the transient concentration profile **410** and the Cottrell concentration profile **420**.

**[0080]** FIG. 4B represents the formation of different concentration profiles when incubation times  $t_1$  through  $t_5$  pass before the input signal is applied to the electrodes. The concentration profile at  $t_5$ , representing a 15 to 30 second incubation period, depicts a substantially constant concentration distribution of measurable species throughout the sample, which would provide a Cottrell decay having a decay constant of -0.5. Thus, the area under the  $t_5$  line and the related measurable species concentration does not substantially change until a relatively large distance away from the electrode surface **402**.

**[0081]** In contrast to the  $t_5$  line, the  $t_4$  line has an incubation period of 1 to 12 seconds and a variant concentration distribution of measurable species in the sample. The  $t_4$  line has slower transient decay constants from -0.30 (1 second) to -0.48 (12 seconds). Thus, the area under the  $t_4$  line and the underlying measurable species concentration undergoes a substantial change from the electrode surface **402** to the upper lid **403** of the reservoir **400** - thus being variant.

**[0082]** As the incubation period is further reduced to 0.4 to 1 second in  $t_3$  or to 0.1 to 0.3 second in  $t_2$ , the transient

decay constants may range from -0.25 to -0.3 for  $t_3$  and from -0.15 to -0.25 for  $t_2$ , respectively. The  $t_1$  decay, representing a 0.01 to 0.1 second incubation period may have a transient decay constant of -0.15 or less. As the incubation period is reduced from  $t_4$  to  $t_1$ , the area under the lines and the related measurable species concentration between the electrode surface **402** and the upper lid **403** of the reservoir **400** becomes increasingly variant.

**[0083]** By having a lower concentration of the measurable species at the electrode surface **402** than in the remaining portion of the reservoir **400**, such as represented by the  $t_1$  through  $t_4$  variant concentration distribution profiles of FIG. 4B, the rate of current decay may be slower than the -0.5 decay constant required for Cottrell decay. This slower decay may be attributable to the large concentration of measurable species farther from the electrode surface **402** reaching the electrode surface more rapidly than if the measurable species was distributed evenly throughout the sample reservoir **400**. Similarly, faster decay rates may be obtained when a higher concentration of the measurable species is present at the electrode surface **402** than in the remaining portion of the sample reservoir **400**.

**[0084]** FIG. 4C represents the relation between measurable species concentrations in the reservoir **400** and current decay constants. Measurable species concentration profiles **430** and **440** have slower and faster decay rates, respectively, than **420**, which corresponds to the -0.5 Cottrell decay constant. For concentration profile **430** having a decay constant less than the -0.5 Cottrell decay constant, such as -0.3, the rate of current decay will be slower than that observed for a Cottrell system. Similarly, for concentration profile **440** having a decay constant greater than the -0.5 Cottrell decay constant, such as -0.7, the rate of current decay will be faster than that observed for a Cottrell system. Thus, in comparison to the -0.5 Cottrell decay constant represented by **420**, transient decay constants **430**, **440** reflect variant concentration distributions of the measurable species in the reservoir **400**.

**[0085]** When long incubation periods are used to generate Cottrell decay, the amount of measurable species produced during the measurement excitation is small compared to the amount of measurable species produced during the prior incubation period. Thus, unlike the concentration profile **420** representing complete redox conversion of the analyte to a measurable species before application of the input signal, concentration profiles **430**, **440** represent incomplete conversion. Furthermore, any change in diffusion rate of the measurable species to the electrode from convection or other pathways also is small in relation to the amount of measurable species generated during the incubation period. Thus, long incubation periods substantially negate effects that would alter the -0.5 Cottrell decay constant.

**[0086]** In contrast, when short incubation periods, such as 12 seconds, 10 seconds, and shorter are used, the amount of measurable species produced during the measurement excitation and any change in diffusion rates from processes other than diffusion may provide an actual decay rate that is slower than the -0.5 Cottrell value. This decay process can be described by the following normalized current equation, Equation (2):

$$f(t) = t^{-a+b+c} \quad (2),$$

where **a** is the portion of the decay constant from measurable species formed during the incubation period, **b** is the portion of the decay constant from measurable species formed during the measurement excitation, and **c** is the portion of the decay constant arising from variations in the concentration distribution of the measurable species in the sample reservoir. Negative values of **b** and **c** result in an increase in measured measurable species concentration, while positive values of **b** and **c** result in a decrease in measured measurable species concentration. Thus, if either **a** or **b** are non-zero, a deviation from the **a** decay value will result. As a Cottrell decay is provided by a -0.5 value for **a**, a significant contribution from **b** or **c** provides a transient decay constant. Under Equation (2), term **a** controls the decay constant obtained from the concentration profile **420**, while term **b** would significantly contribute to the decay constant obtained from the concentration profiles **430** and **440**, where the input signal is applied before redox conversion of the analyte is complete.

**[0087]** Equation (2) establishes that the decay constant of a system can vary over time in response to which of these underlying factors affect the current decay at the time of measurement. For example, longer incubation periods increase **a** while reducing **b** because the more analyte converted to the measurable species during the incubation period, the less analyte remains in the sample for conversion to the measurable species during the excitation.

**[0088]** The redox conversion of analyte to measurable species occurs in hydrated reagent layers. Because thicker reagent layers require longer to hydrate, thicker reagent layers will provide an increase in the **b** term in relation to the **a** term if the input signal is applied before the reagent layer is hydrated. Cottrell decay is not observed before the reagent layer is hydrated due to the contribution to the decay constant of measurable species formed during the measurement excitation, the **b** term of Equation (2). This was recognized in column 4, lines 58-59 of the '069 patent, which discloses that incomplete wetting of the reagent results in a failure of the system to follow the Cottrell curve decay, resulting in an inaccurate analyte concentration value being obtained. Thus, transient decay constants may be obtained from partially hydrated reagent layers resulting from relatively short initial incubation periods.

**[0089]** Sensor strip reservoirs including a substantially constant concentration distribution of the measurable species

may reduce any affect on the decay constant attributable to **c**. The **c** term also may affect the decay constant if the excitation duration is too long for the sample volume, resulting in a rapid decrease in the measurable species concentration as the distance increases from the surface of the electrode. Using a short excitation or multiple short excitations combined with one or multiple relaxations may assist in reducing the effect of the **c** term on the decay constant.

[0090] For example, the '069 patent describes a system that provides a -0.5 Cottrell decay constant when a 160 second initial incubation period is combined with a 50  $\mu\text{L}$  sample reservoir. For this system, if the incubation period were sufficiently shortened, the **b** term of Equation (2) would increase, thus providing non-Cottrell decay. Similarly, if the reservoir volume were sufficiently reduced, non-Cottrell decay would result from an increase in the **c** term of Equation (2).

[0091] FIG. 5 depicts decay constants obtained from sensor strips having reservoir volumes of about 3.5  $\mu\text{L}$  and electrode to lid distances of about 250  $\mu\text{m}$  after varying incubation periods for whole blood samples containing 50, 100, 200, or 400 mg/dL of glucose. The rate of decay increased with increasing incubation time; however, a Cottrell decay constant of -0.5 was not obtained within the six second incubation period. Thus, the system provided transient decays under these circumstances.

[0092] Table I, below, provides the decay constants for the 1-6 second incubation periods of FIG. 5 and provides projected constants for 10 and 15 second incubation periods. A projected decay constant also is provided for an extended 20 second incubation period.

Table I

Input Signal	Incubation Period	50 mg/dL	100 mg/dL	200 mg/dL	400 mg/dL
4-1-1	1	-0.2479	-0.23823	-0.2119	-0.17947
4-2-1	2	-0.337	-0.30593	-0.282	-0.2631
4-4-1	4	-0.37417	-0.34993	-0.3442	-0.32837
4-5-1	5	-0.3877	-0.3734	-0.3549	-0.35283
4-6-1	6	-0.3979	-0.38273	-0.373	-0.36483
Projected	10	-0.44596	-0.42622	-0.42066	-0.42275
Projected	15	-0.4786	-0.45853	-0.45679	-0.46475
Projected	20	-0.50176	-0.48146	-0.48242	-0.49456

[0093] In each instance, the input signal included an initial excitation of four seconds, followed by an open circuit type intermittent incubation period of varying duration, and a measurement excitation of one second during which the current was recorded. The sensor system did not achieve Cottrell decay condition during any of the incubation periods from one to six seconds. The sensor system would not be projected to achieve a Cottrell decay condition within twelve seconds even at low 50 mg/dL glucose concentrations. Preferable transient decay constants are from -0.001 to -0.48 and from -0.52 to -1. More preferable transient decay constants are at most -0.45, at most 0.35, and at most -0.3. Other transient decay constants may be used.

[0094] FIGs. 6A-6C plot the current profiles obtained from three sensor strips each having a different average initial thickness of the reaction layer at initial incubation periods of 0.125, 0.5, 1, 2, 4, and 6 seconds. The sample reservoir of each strip was about 1  $\mu\text{L}$ . The FIG. 6A plot was obtained from multiple sensor strips having reaction layers with an average initial thickness from about 15  $\mu\text{m}$  to about 20  $\mu\text{m}$  ("thick"). The FIG. 6B and 6C plots were obtained from multiple sensor strips having reaction layers with average initial thicknesses from 10  $\mu\text{m}$  to 15  $\mu\text{m}$  ("intermediate") and from 1  $\mu\text{m}$  to 2  $\mu\text{m}$  ("thin"), respectively. Other thicknesses may be used.

[0095] The figures establish the relationship of incubation time, reagent layer thickness, and the associated rate of layer hydration. Thicker reagent layers required a longer time for the reagent layer to hydrate, and the greater the time required for the reagent layer to hydrate, the longer the time before the current decay reached a point of continual decrease. Current values obtained from decreasing transient decays are preferred for correlating with the analyte concentration of the sample.

[0096] For the thick layered strips of FIG. 6A, continually decreasing current decays were obtained after an incubation period of about 4 seconds or greater. However, for incubation periods of about 2 seconds and less, a continually decreasing current decay was not obtained for thick layered strips until about 2 or more seconds of input signal were applied.

[0097] For the intermediate thickness reagent layer of the FIG. 6B sensor strips, continually decreasing current decays were obtained after an incubation period of about 2 seconds or greater. For incubation periods of about 1 second and less, about 2 or more seconds of input signal provided a continually decreasing current decay.

[0098] For the thin reagent layer of the FIG. 6C sensor strips, continually decreasing current decays were obtained after an incubation period of about 1 second or greater. For incubation periods of about 0.5 second and less, about 1 or more seconds of input signal provided a continually decreasing current decay. Thus, thinner reagent layers may be combined with shorter incubation periods to provide a shorter total analysis time, while thicker reagent layers may require longer duration incubation periods and/or input signals.

[0099] FIGs. 7A-7B plot the natural logs of current vs. time for whole blood samples including 100 or 300 mg/dL of glucose at 40% hematocrit obtained after a 6 second initial incubation period. The sample reservoir volumes and reagent layer initial average thicknesses were as in FIGs. 6A-6C, above. The plots were generated from current values obtained during the first 5 seconds of a 10 second excitation, where the  $a$  term of Equation (2) dominates the decay constant. Each of the observed decay constants - slopes of the  $\ln(\text{current, nA})$  vs.  $\ln(\text{time, sec})$  plots - differ from the -0.5 Cottrell decay constant, having transient decay constants ranging from about -0.35 to about -0.45. Thus, even at the longest initial incubation period of 6 seconds, Cottrell decay is not observed.

[0100] FIGs. 8A-8C are current decay profiles from a 0.25 second initial incubation period followed by a gated input signal including 0.5 second excitations and 0.25 second relaxations, to provide a duty cycle duration of 0.75 second. Both intermediate and thin reagent layer sensor strips having sample reservoir volumes of about 1  $\mu\text{L}$  were used to analyze whole blood samples including 50, 100, or 400 mg/dL of glucose at 40% hematocrit. Continually decreasing current decays that may be correlated to the 50 mg/dL analyte concentration in the sample were obtained within 0.75 second for the thin reagent layer, thus during the first excitation. For the thicker intermediate reagent layer, continually decreasing current decays were obtained within 3 seconds, thus during the third excitation.

[0101] FIG. 8D is a calibration plot obtained by plotting the endpoint currents ( $p_1$ ,  $p_2$ ,  $p_3$ ) of the first three excitations obtained from thin reagent layer sensor strips as depicted in FIGs. 8A-8C. The figure establishes that current values taken after very short incubation periods of 0.25 second in accord with the present invention may be accurately correlated ( $R^2 = 0.999$ ) with the actual plasma glucose concentration of whole blood samples.

[0102] FIG. 8E is a calibration plot obtained by plotting the endpoint currents ( $p_4$ ,  $p_5$ ,  $p_6$ ) of excitations 4, 5, and 6 obtained from sensor strips having intermediate thickness reagent layers as depicted in FIGs. 8A-8C. The figure establishes that current values taken after a very short 0.25 second initial incubation period and multiple duty cycles including 0.5 second excitations and 0.25 second relaxations in accord with the present invention may be accurately correlated ( $R^2 = 0.99$ ) with the actual plasma glucose concentration of whole blood samples.

[0103] To provide a clear and consistent understanding of the specification and claims of this application, the following definitions are provided.

[0104] "Sample" is a composition that may contain an unknown amount of the analyte. A sample may be aqueous, such as whole blood, urine, saliva, or a derivative, such as an extract, a dilution, a filtrate, or a reconstituted precipitate.

[0105] "Incubation period" is the length of time that the sample reacts with the reagents before an excitation is applied, such as before the first excitation is applied and/or the time between excitations if the input signal includes multiple excitations.

[0106] "Measurable species" is any electrochemically active species that may be oxidized or reduced under an appropriate potential at an electrode surface.

[0107] An "Oxidoreductase" facilitates the oxidation or reduction of an analyte or biological substrate. See, for example the Oxford Dictionary of Biochemistry and Molecular Biology, Revised Edition, A.D. Smith, Ed., New York: Oxford University Press (1997) pp. 161, 476, 477, and 560.

[0108] While various embodiments of the invention have been described, it will be apparent to those of ordinary skill in the art that other embodiments and implementations are possible within the scope of the invention.

## Claims

1. A method for determining an analyte concentration in a sample, comprising:

introducing the sample including an enzyme to a sensor strip;  
 applying a signal to the sample after an incubation period of at least 0.1 second to at most 8 seconds, the signal including excitations, each excitation having a duration from 0.1 to 5 seconds;  
 generating a current signal having a transient decay in response to a redox reaction of a measurable species, the measurable species formed by way of a redox reaction of a portion of the analyte in the sample, where the generated current signal results from at least one of the excitations having the duration from 0.1 to 5 seconds; and  
 determining the analyte concentration from the transient decay of the generated current signal where the transient decay has a decay constant greater or less than -0.5.

2. The method of claim 1, where the measurable species comprises at least one mediator.

3. The method of claim 1, where the incubation period is at most 6 seconds.
4. The method of claim 1, where the incubation period and the application of the signal are complete in at most 6 seconds.
- 5 5. The method of claim 1, where the transient decay is decreasing and is obtained within 0.5 to 5 seconds.
6. The method of claim 5, where the analyte concentration is determined from the transient decay of a single excitation.
7. The method of claim 1, where the transient decay has a decay constant from -0.52 to -1, or at most -0.35.
- 10 8. The method of claim 1, where the generated signal from which the analyte concentration is determined comprises a current value generated within 2 seconds of applying the signal to the sample.
9. The method of claim 1, where determining the analyte concentration from the generated signal is complete within 3 seconds of applying the signal.
- 15 10. The method of claim 1, where the sample resides in a reservoir defined by a sensor strip base and the bottom surface of a lid, where  
the base is 50 to 150 micrometers from the bottom surface of the lid,  
the volume of the sample within the reservoir is at most 3.5 microliters, and  
the incubation period is at most 6 seconds.
- 20 11. The method of claim 10, where the reservoir height from the sensor strip base to the bottom of the lid is at most 100 micrometers, the volume of the sample within the reservoir is at most 3 microliters, the reservoir includes at least one reagent layer having an average initial thickness of at most 2 micrometers, and the incubation period is at most 2 seconds.
- 25 12. The method of claim 10 or claim 11, further comprising generating a variant concentration distribution of the measurable species in the sample reservoir.
- 30 13. The method of any one of claims 1-11, the signal including at least three excitations.
14. The method of claim 13, where the excitations are separated by at least two relaxations, each relaxation having a duration from 0.1 to 3 seconds.
- 35 15. The method of claim 13, where the applied signal includes at least 2 duty cycles applied within 5 seconds.

#### Patentansprüche

- 40 1. Verfahren zur Ermittlung einer Analyt-Konzentration in einer Probe, umfassend:
- Zuführen der Probe, die ein Enzym enthält, zu einem Sensorstreifen;  
Anlegen eines Signals an die Probe nach einer Inkubationszeit von mindestens 0,1 Sekunden bis höchstens 8 Sekunden, wobei das Signal Anregungen enthält, wobei jede Anregung eine Dauer von 0,1 bis 5 Sekunden hat;  
Erzeugen eines Stromsignals, das ein transientes Abklingen in Reaktion auf eine Redox-Reaktion einer messbaren Spezies aufweist, wobei die messbare Spezies durch eine Redox-Reaktion eines Teils des Analyts in der Probe gebildet wurde, wobei das erzeugte Stromsignal von mindestens einer der Anregungen mit einer Dauer von 0,1 bis 5 Sekunden resultiert; und  
Ermitteln der Analyt-Konzentration von dem transienten Abklingen des erzeugten Stromsignals, wobei das transiente Abklingen eine Abkling-Konstante größer oder geringer als -0,5 hat.
- 45 2. Verfahren nach Anspruch 1, wobei die messbare Spezies mindestens einen Mediator umfasst.
- 55 3. Verfahren nach Anspruch 1, wobei die Inkubationszeit höchstens 6 Sekunden ist.
4. Verfahren nach Anspruch 1, wobei die Inkubationszeit und das Anlegen des Signals in höchstens 6 Sekunden abgeschlossen sind.

## EP 2 083 674 B1

5. Verfahren nach Anspruch 1, wobei das transiente Abklingen fallend ist und innerhalb von 0,5 bis 5 Sekunden erhalten wird.
- 5 6. Verfahren nach Anspruch 5, wobei die Analyt-Konzentration von dem transienten Abklingen einer einzelnen Anregung ermittelt wird.
7. Verfahren nach Anspruch 1, wobei das transiente Abklingen eine Abkling-Konstante von -0,52 bis -1, oder höchstens -0,35 hat.
- 10 8. Verfahren nach Anspruch 1, wobei das erzeugte Signal, von dem die Analyt-Konzentration ermittelt wird, einen Stromwert umfasst, der innerhalb von 2 Sekunden von Anlegen des Signals an die Probe erzeugt wird.
9. Verfahren nach Anspruch 1, wobei das Ermitteln der Analyt-Konzentration ab dem Erzeugen des Signals innerhalb von 3 Sekunden von Anlegen des Signals abgeschlossen ist.
- 15 10. Verfahren nach Anspruch 1, wobei die Probe in einem Behälter bleibt, der durch ein Sensorstreifenunterteil und die Unterseite eines Deckels definiert wird, wobei das Unterteil 50 bis 150 Mikrometer von der Unterseite des Deckels ist, das Volumen der Probe innerhalb des Behälters höchstens 3,5 Mikroliter ist, und die Inkubationszeit höchstens 6 Sekunden beträgt.
- 20 11. Verfahren nach Anspruch 10, wobei die Behälterhöhe von dem Sensorstreifenunterteil bis zur Unterseite des Deckels höchstens 100 Mikrometer, das Volumen der Probe innerhalb des Behälters höchstens 3 Mikroliter, der Behälter mindestens eine Reagenzschicht mit einer durchschnittlichen initialen Dicke von höchstens 2 Mikrometer und die Inkubationszeit von höchstens 2 Sekunden ist.
- 25 12. Verfahren nach Anspruch 10 oder Anspruch 11, ferner umfassend Erzeugen einer Variantenkonzentrationsverteilung der messbaren Spezies in dem Probenbehälter.
- 30 13. Verfahren nach einem der Ansprüche 1 bis 11, wobei das Signal mindestens drei Anregungen enthält.
14. Verfahren nach Anspruch 13, wobei die Anregungen durch mindestens zwei Relaxationen separiert sind, wobei jede Relaxation eine Dauer von 0,1 bis 3 Sekunden hat.
- 35 15. Verfahren nach Anspruch 13, wobei das angelegte Signal mindestens 2 Arbeitszyklen innerhalb von 5 Sekunden anwendet.

### Revendications

- 40 1. Méthode de détermination de la concentration d'un analyte dans un échantillon, comprenant les étapes consistant à :
- agencer l'échantillon incluant un enzyme sur une bandelette réactive ;  
appliquer un signal à l'échantillon après une période d'incubation d'au moins 0,1 secondes jusqu'à 8 secondes  
45 au maximum, le signal incluant les excitations, chacune excitation ayant une durée de 0,1 à 5 secondes ;  
générer un signal de courant ayant une décroissance transitoire, en réponse à une réaction redox d'une espèce mesurable, l'espèce mesurable formée par la réaction redox d'une partie de l'analyte dans l'échantillon, dans lequel le signal de courant généré résultant d'au moins une des excitations ayant la durée de 0,1 à 5 secondes ; et  
déterminer la concentration d'analyte par la décroissance transitoire du signal de courant généré, dans lequel  
50 la décroissance transitoire a une constante de décroissance supérieure ou inférieure à -0,5.
2. Méthode selon la revendication 1, dans laquelle l'espèce mesurable comprend au moins un médiateur.
3. Méthode selon la revendication 1, dans laquelle la période d'incubation est 6 secondes au maximum.
- 55 4. Méthode selon la revendication 1, dans laquelle la période d'incubation et l'application du signal sont terminés en 6 seconds au maximum.

## EP 2 083 674 B1

- 5
- 6
- 7
- 8
- 10
- 15
- 20
- 25
- 30
- 35
- 40
- 45
- 50
- 55
5. Méthode selon la revendication 1, dans laquelle the décroissance transitoire décroît et est obtenue en 0,5 à 5 seconds.
  6. Méthode selon la revendication 5, dans laquelle la concentration d'analyte est déterminée de la décroissance transitoire d'une seule excitation.
  7. Méthode selon la revendication 1, dans laquelle la décroissance transitoire a une constante de décroissance de -0,52 à -1, ou -0,35 au maximum.
  8. Méthode selon la revendication 1, dans laquelle le signal généré, duquel la concentration d'analyte est déterminée, comprend une valeur de courant générée pendant 2 secondes de l'application du signal à l'échantillon.
  9. Méthode selon la revendication 1, dans laquelle la détermination de la concentration d'analyte du signal généré est terminée en 3 secondes de l'application du signal.
  10. Méthode selon la revendication 1, dans laquelle l'échantillon réside dans un réservoir défini par une base de bandelette réactive et le dessous d'un couvercle, dans laquelle la base est 50 à 150 micromètres du dessous du couvercle, la volume de l'échantillon au sein du réservoir est 3,5 microlitres au maximum, et la période d'incubation est 6 secondes au maximum.
  11. Méthode selon la revendication 10, dans laquelle la hauteur à partir du réservoir jusqu'à la base du couvercle est 100 micromètres au maximum, le volume de l'échantillon au sein du réservoir est 3 microlitres au maximum, le réservoir comprend au moins une couche réactive ayant une épaisseur initiale moyenne de 2 micromètres au maximum, et la période d'incubation est 2 seconds au maximum.
  12. Méthode selon la revendication 10 ou la revendication 11, comprenant en outre l'étape consistant à générer une distribution de concentration variante de l'espèce mesurable dans le réservoir d'échantillon.
  13. Méthode selon l'une des revendications 1-11, le signal incluant au moins trois excitations.
  14. Méthode selon la revendication 13, dans laquelle les excitations sont séparées par au moins deux relaxations, chaque relaxation ayant une durée de 0,1 à 3 secondes.
  15. Méthode selon la revendication 13, dans laquelle le signal appliqué comprend au moins 2 rapports cycliques appliqués dans un délai de 5 secondes.

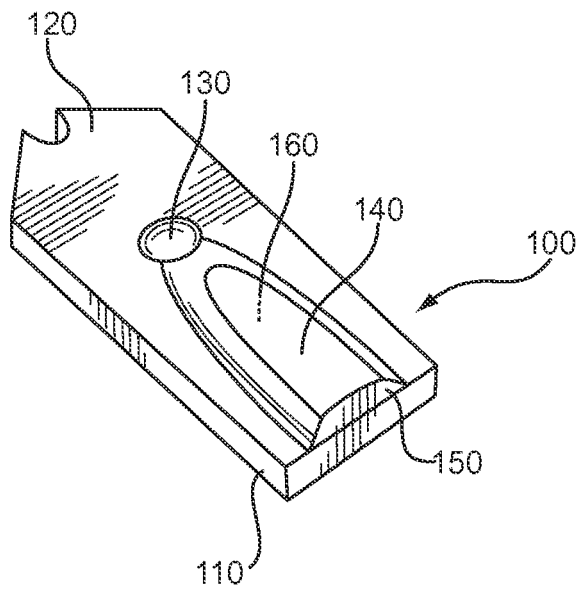

Fig. 1A

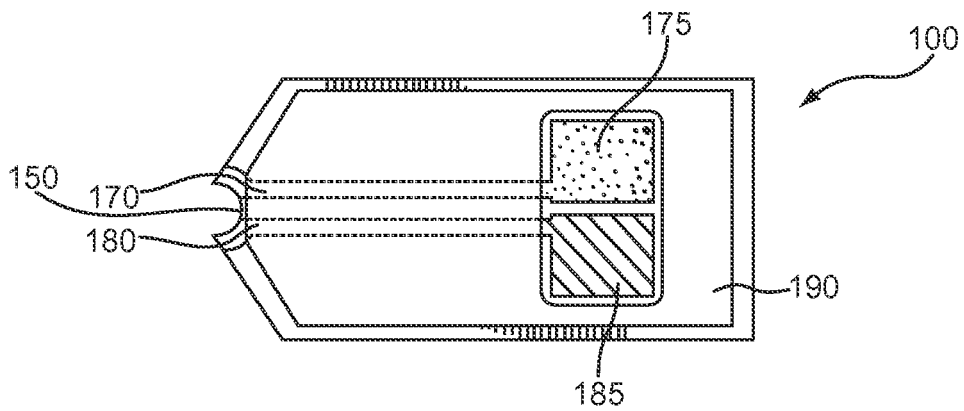

Fig. 1B

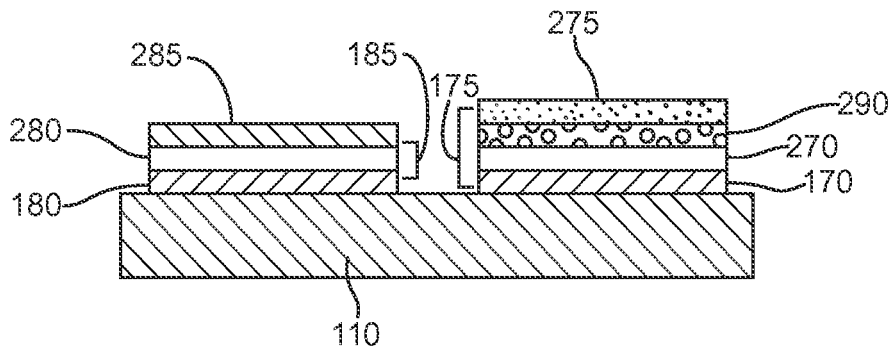

Fig. 2A

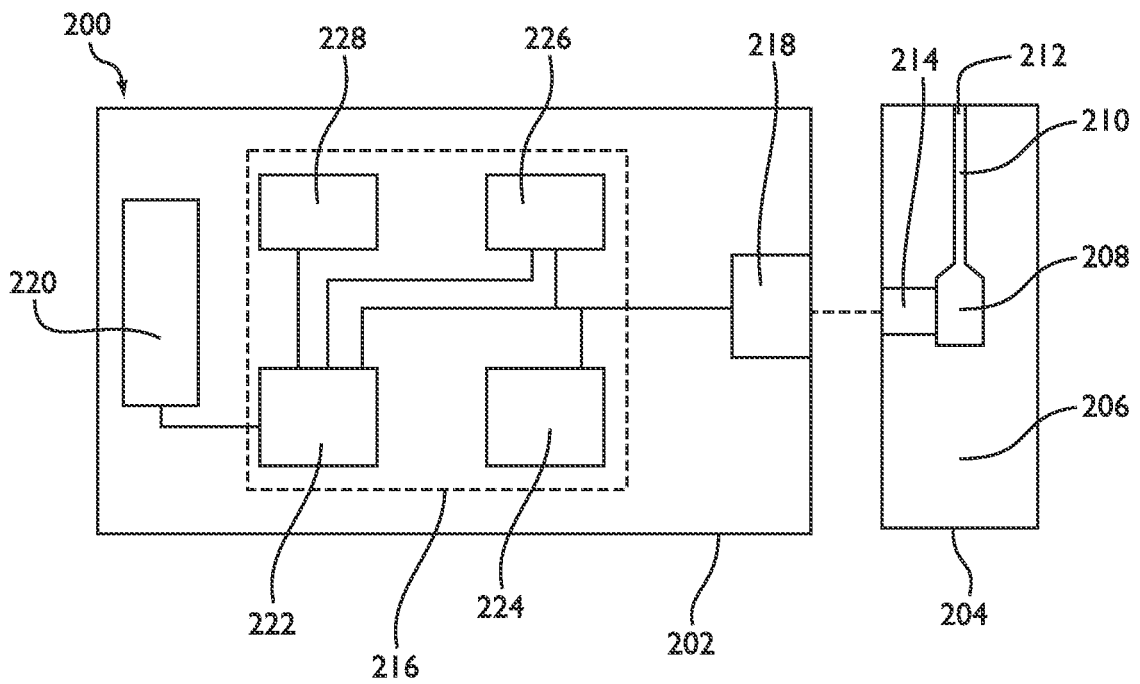

Fig. 2B

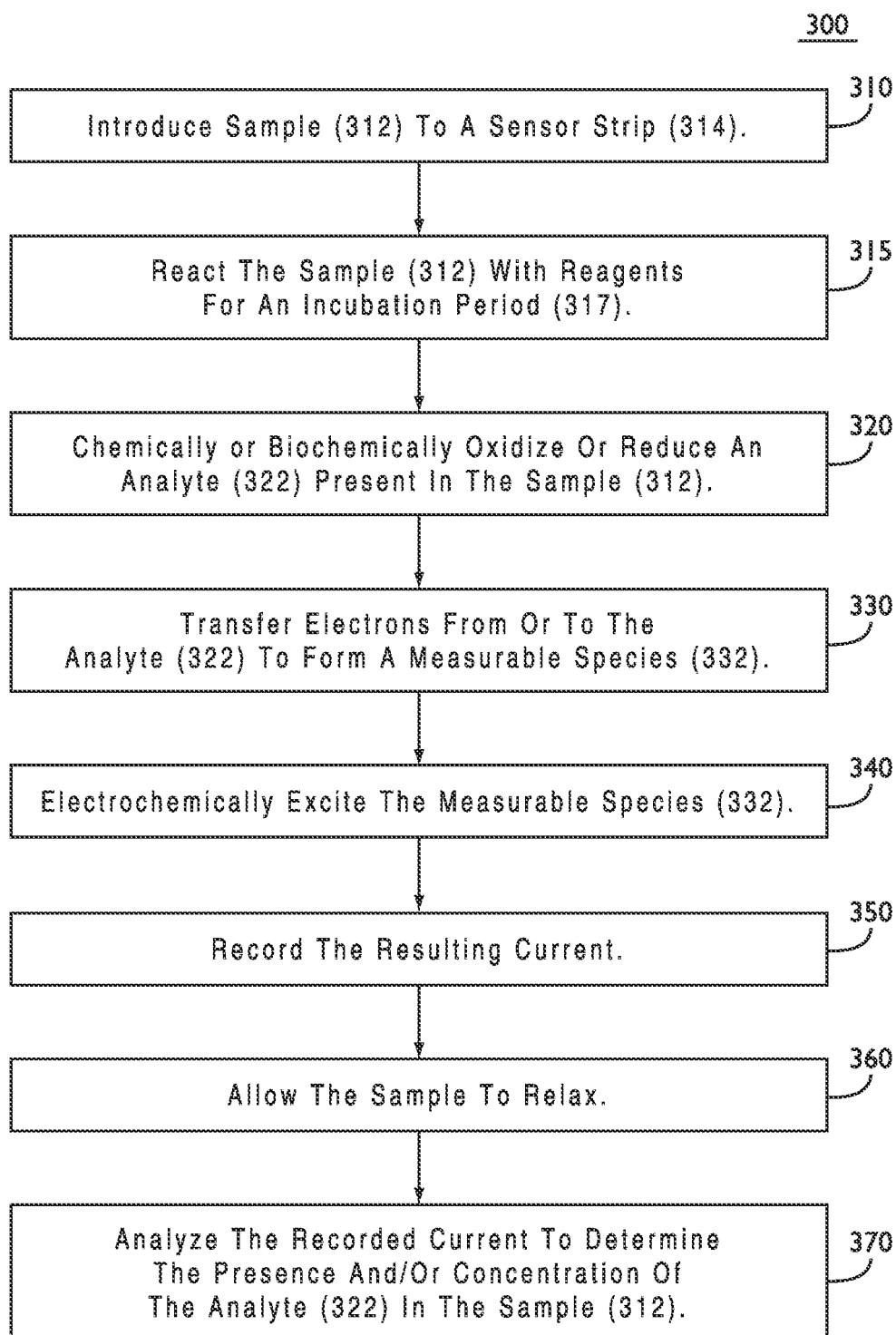

Fig. 3

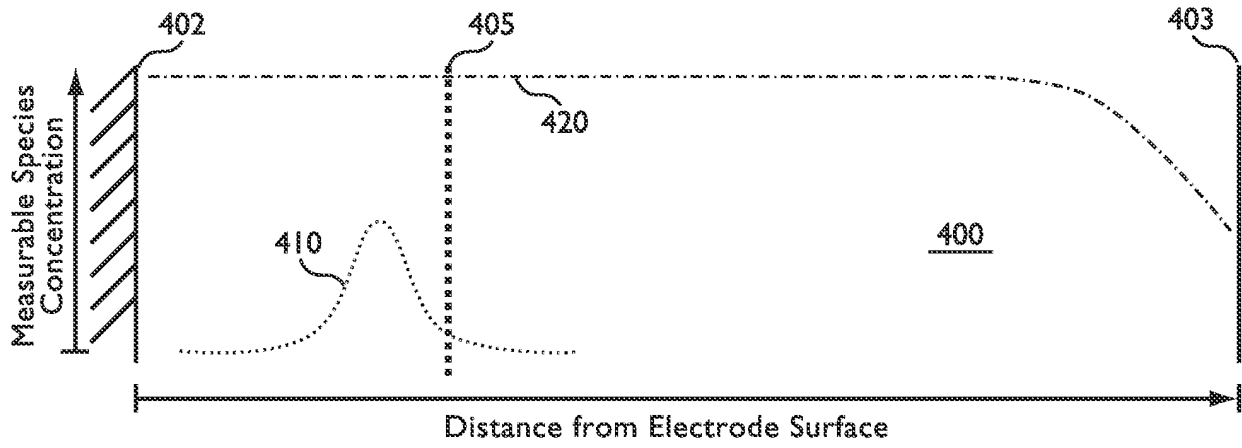

Fig. 4A

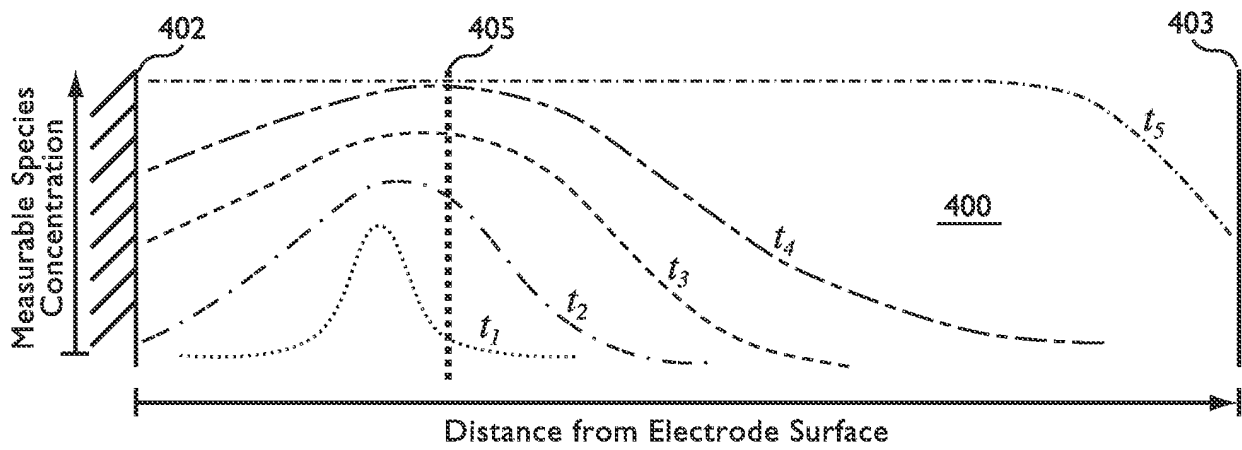

Fig. 4B

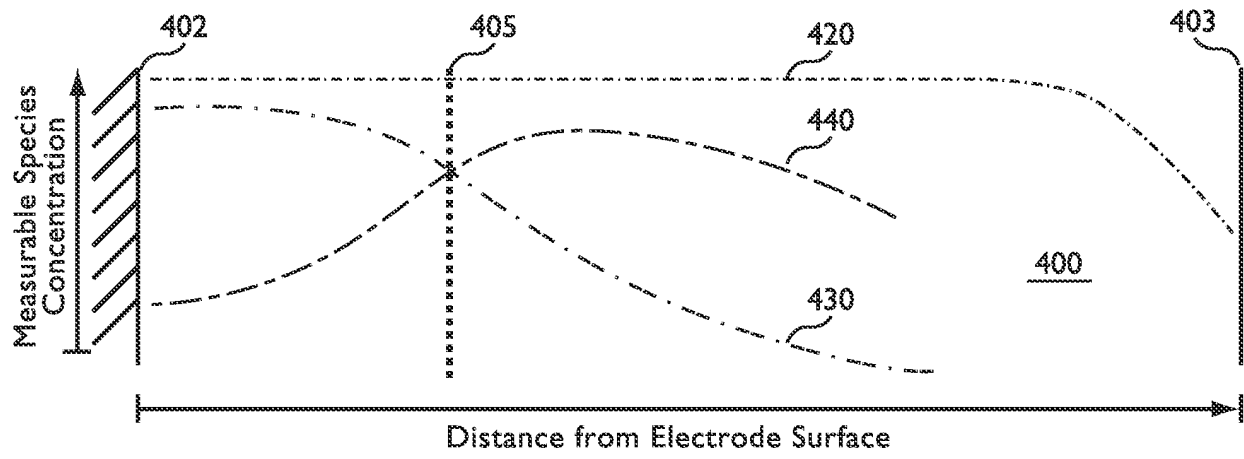

Fig.4C

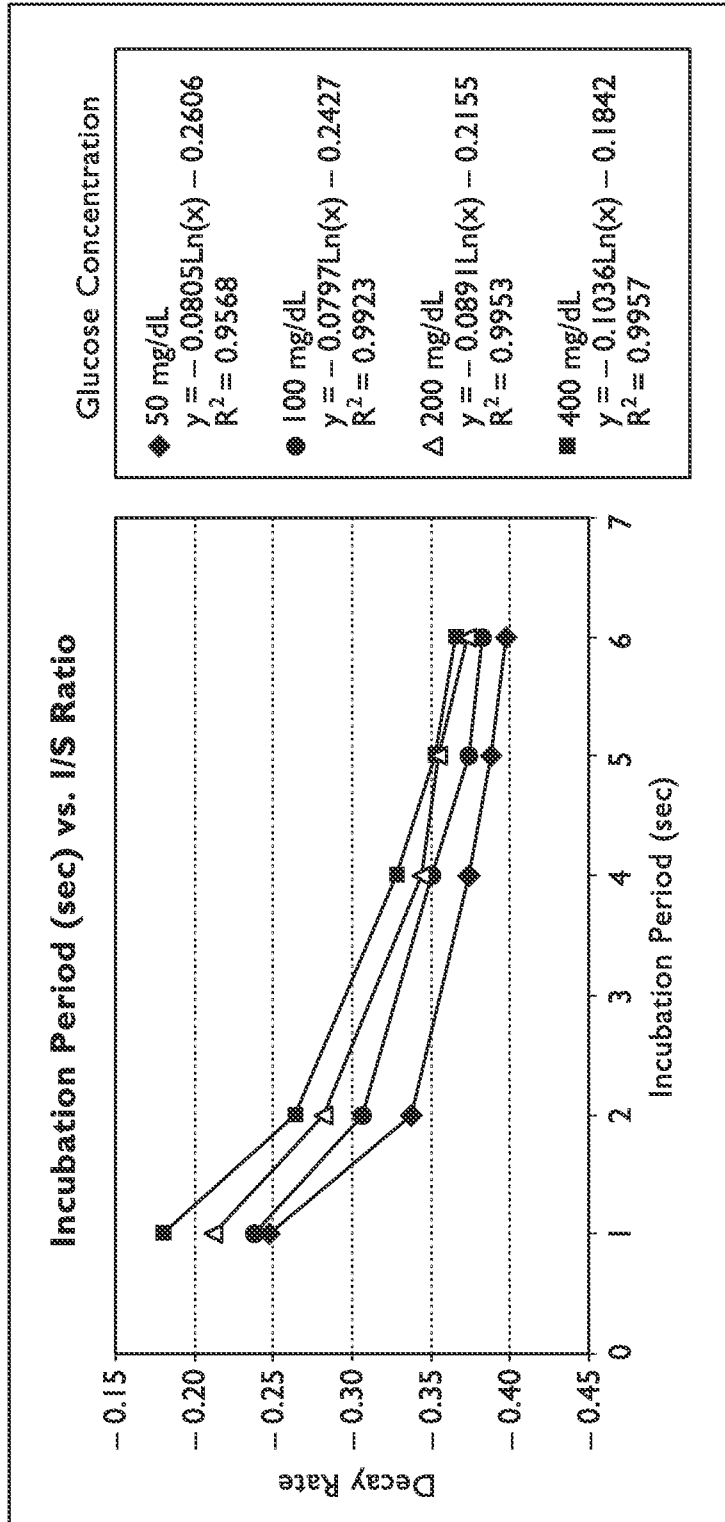

Fig.5

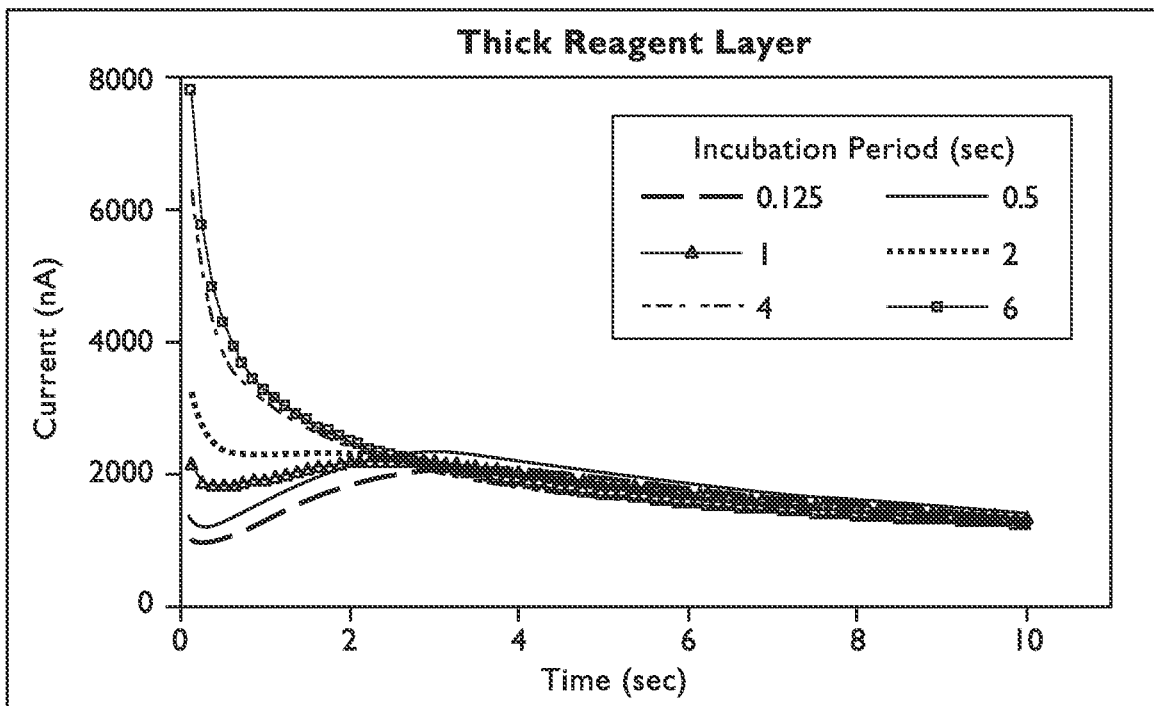

Fig.6A

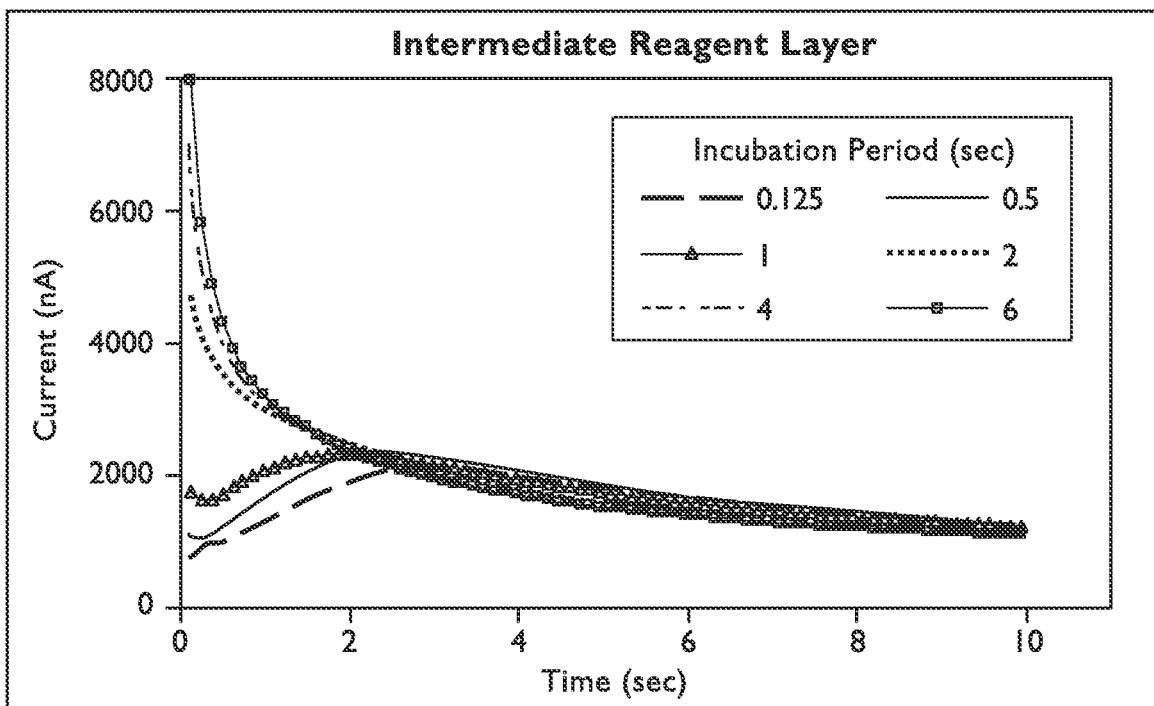

Fig.6B

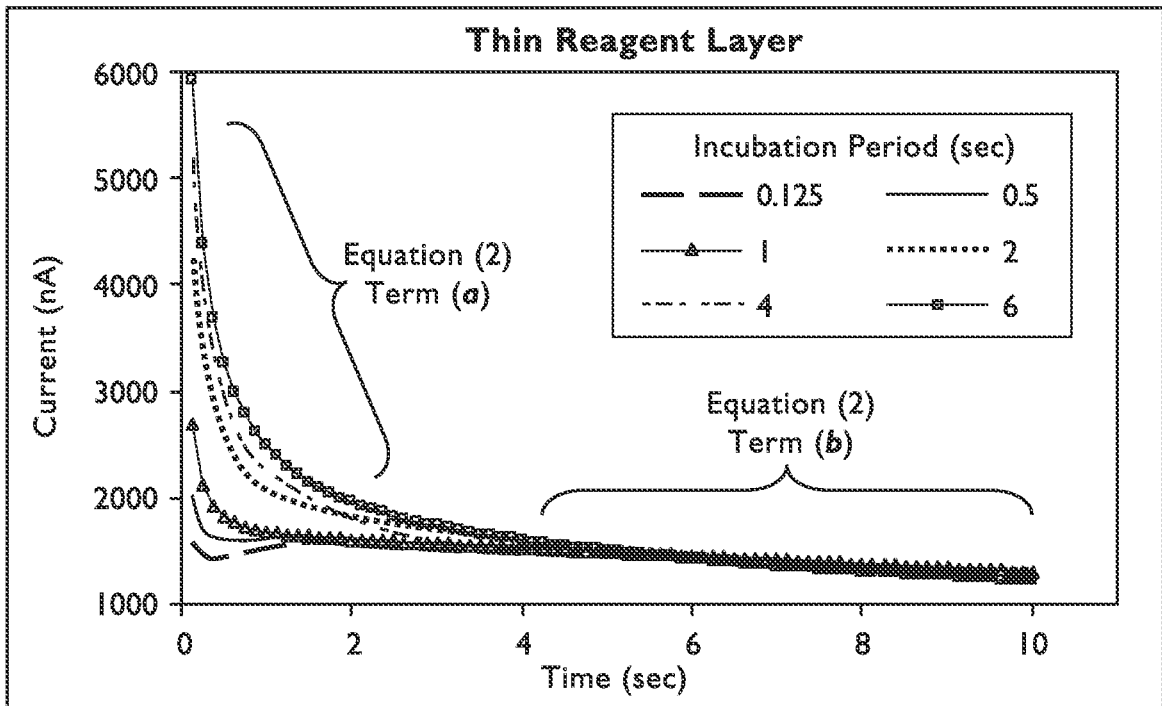

Fig.6C

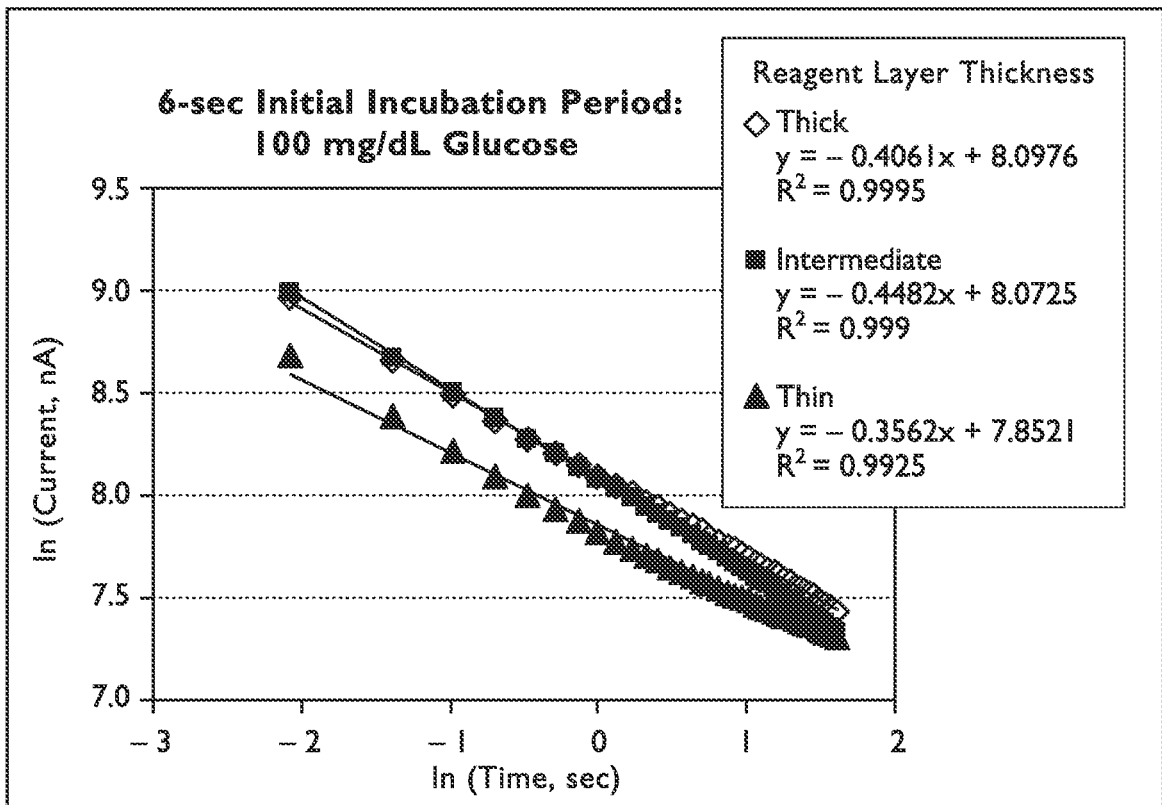

Fig.7A

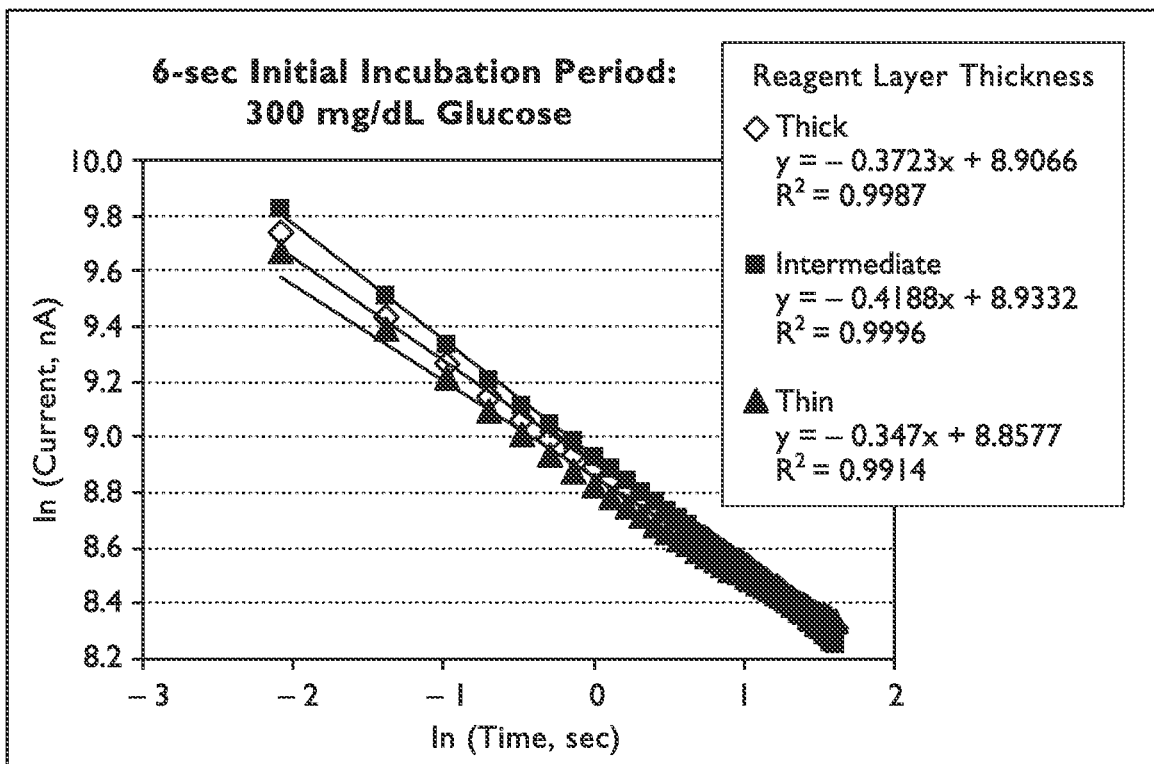

Fig.7B

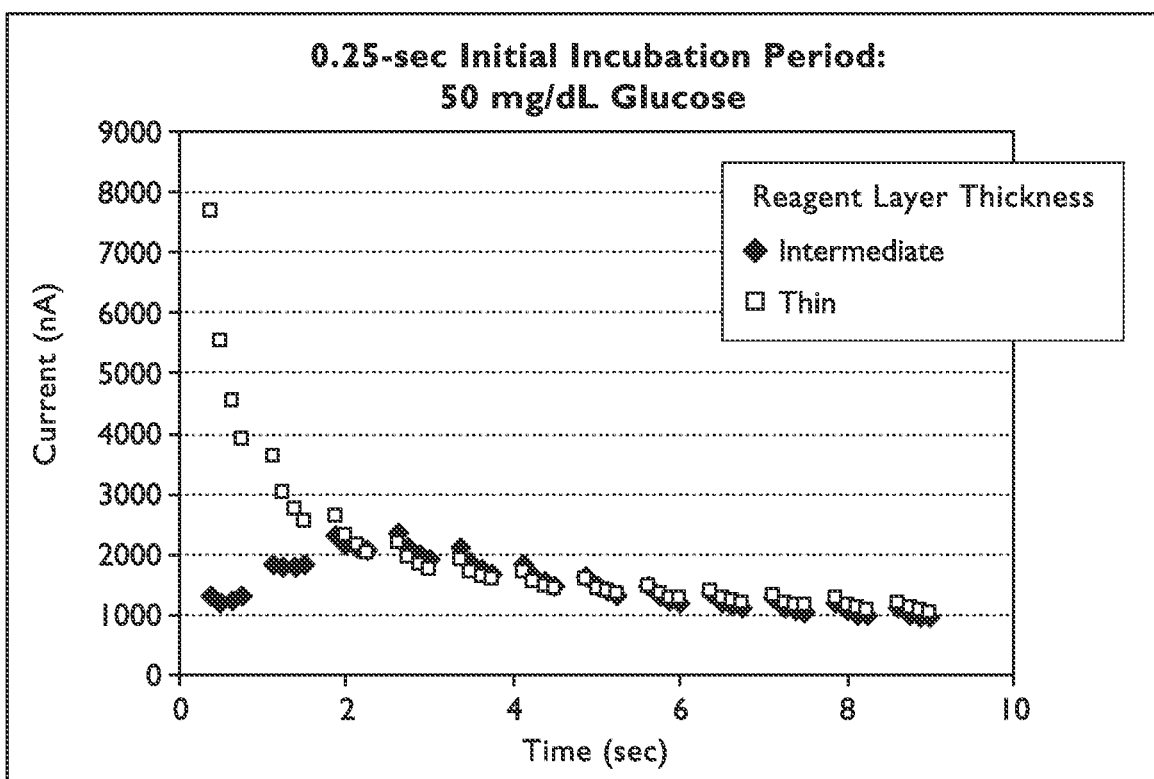

Fig.8A

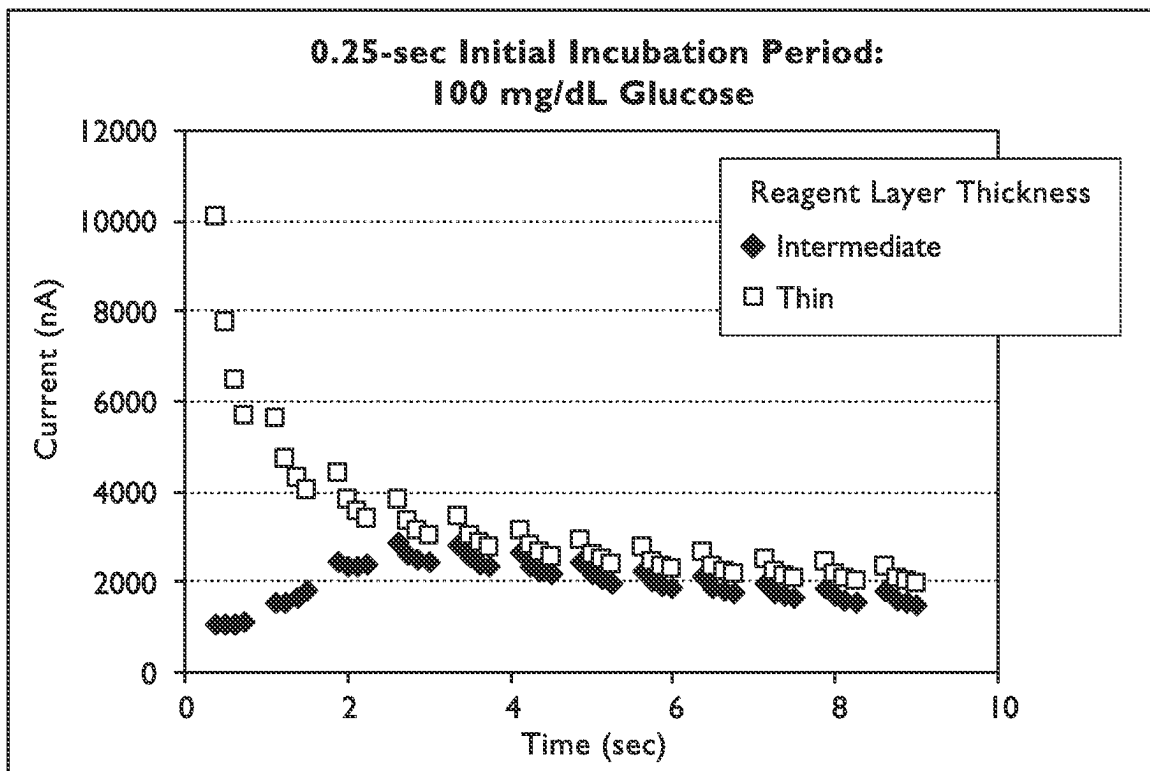

Fig. 8B

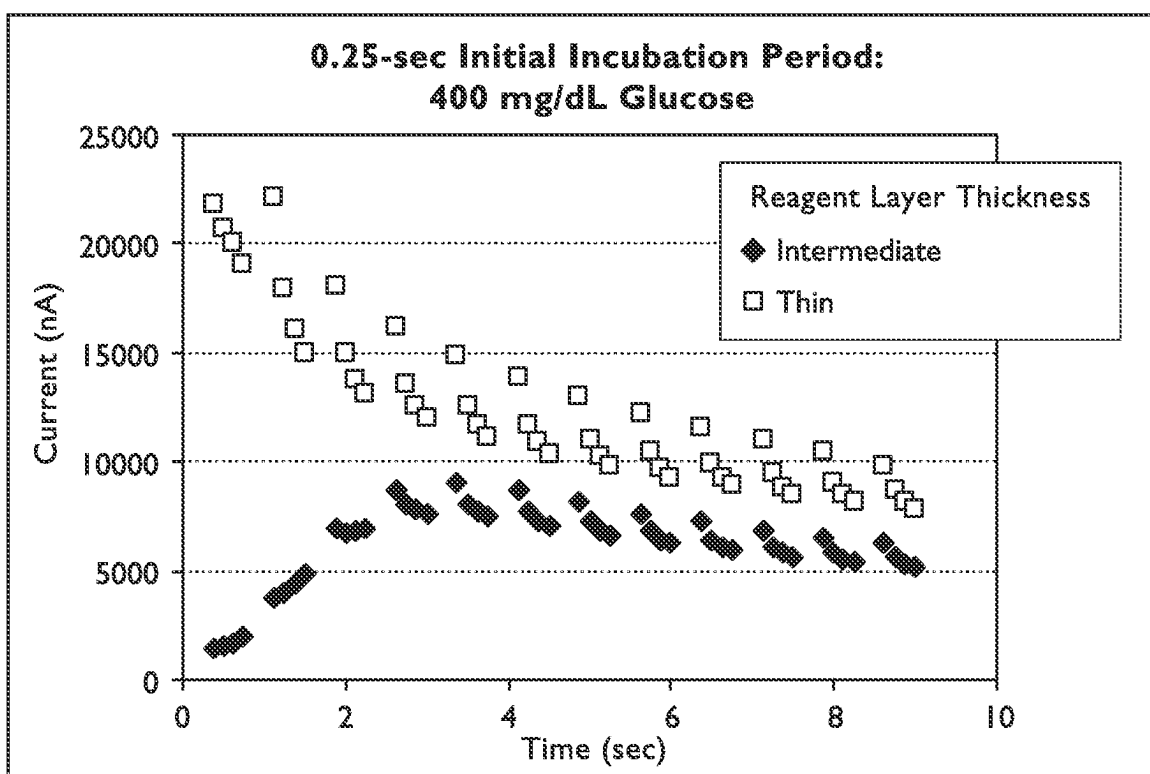

Fig. 8C

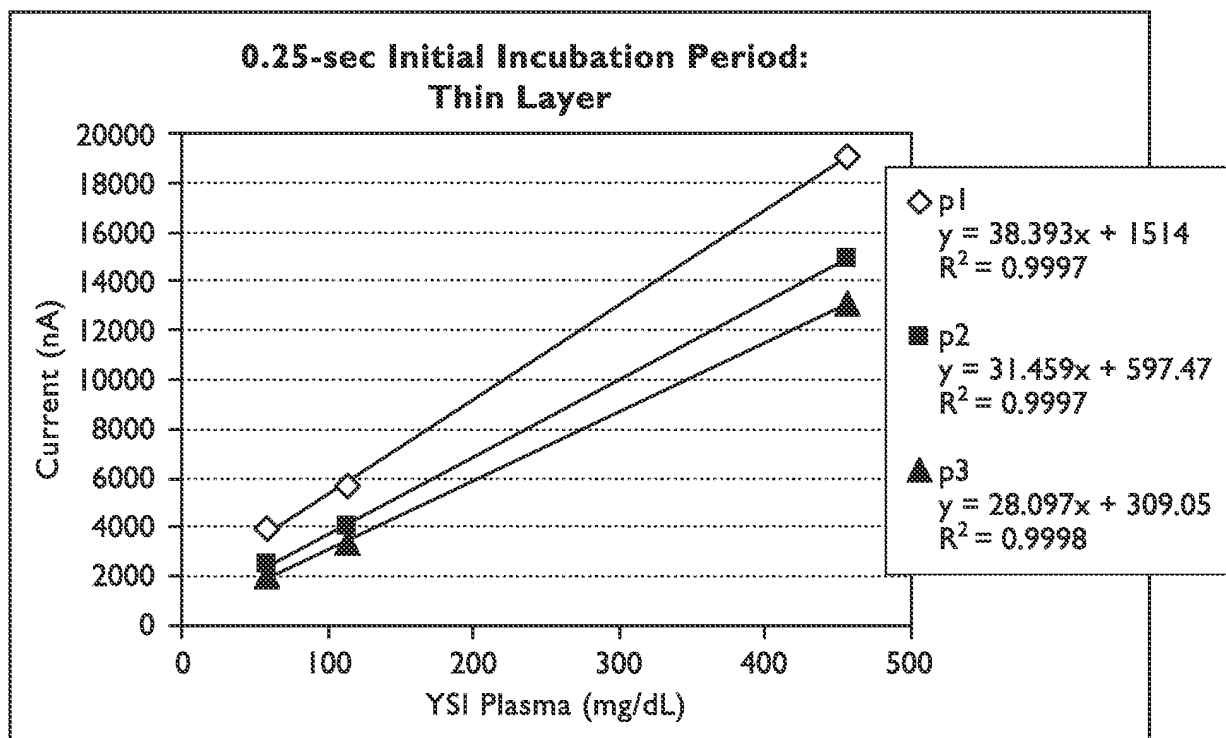

Fig. 8D

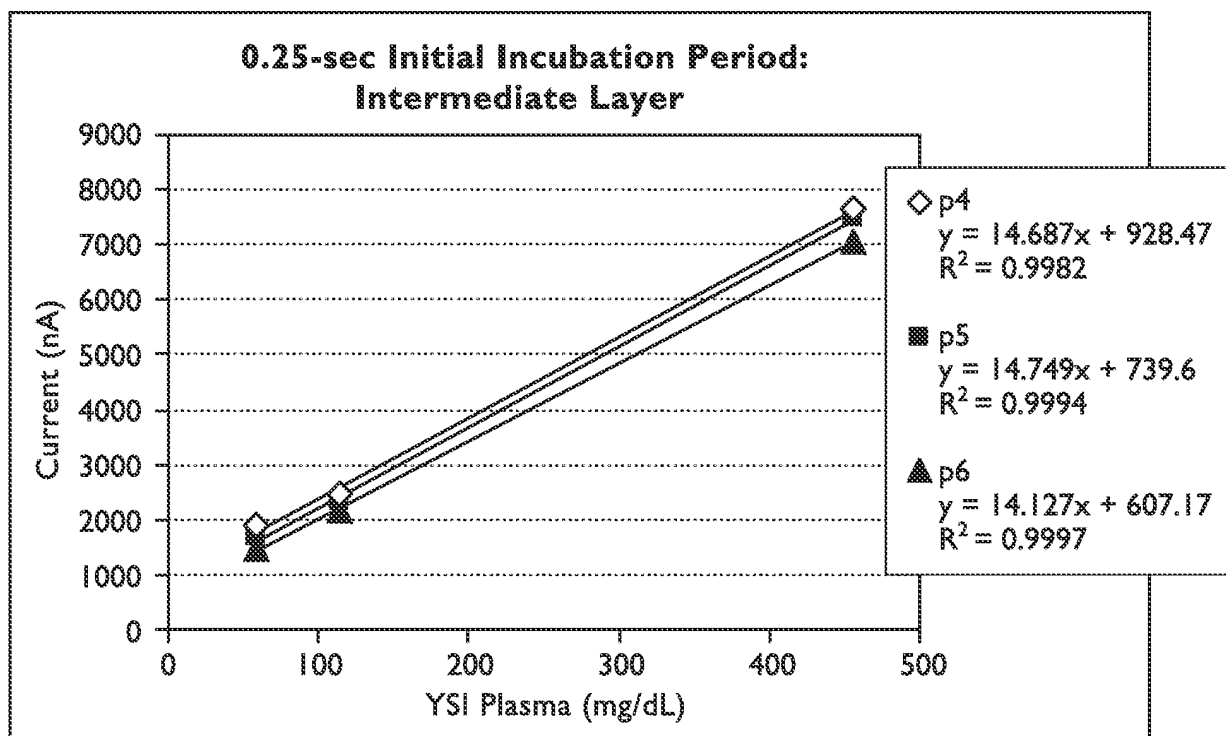

Fig. 8E

**REFERENCES CITED IN THE DESCRIPTION**

*This list of references cited by the applicant is for the reader's convenience only. It does not form part of the European patent document. Even though great care has been taken in compiling the references, errors or omissions cannot be excluded and the EPO disclaims all liability in this regard.*

**Patent documents cited in the description**

- US 85406006 P [0001]
- US 86955706 P [0001]
- US 86962506 P [0001]
- US 5942102 A [0011]
- US 6153069 A [0012]
- US 6413411 B [0012]
- US 20030159944 A1 [0019]
- US 20030155237 A1 [0019]
- US 20050109637 A1 [0019]
- US 5120420 A [0028]
- US 5798031 A [0028] [0036]
- US 5393615 A [0044]
- US 5498542 A [0044]
- US 5520786 A [0044]
- WO 2007013915 A [0076]

**Non-patent literature cited in the description**

- **BARD ; FAULKNER.** Electrochemical Methods: Fundamentals and Applications. 1980, vol. 5, 136-45 [0013]
- Oxford Dictionary of Biochemistry and Molecular Biology. Oxford University Press, 1997, 161, , 476, , 477, , 560 [0107]

专利名称(译)	瞬态衰变安培法		
公开(公告)号	<a href="#">EP2083674B1</a>	公开(公告)日	2018-03-07
申请号	EP2007844290	申请日	2007-10-15
[标]申请(专利权)人(译)	拜尔健康护理有限责任公司		
申请(专利权)人(译)	拜耳医药保健, LLC		
当前申请(专利权)人(译)	ASCENSIA糖尿病护理控股公司		
[标]发明人	WU HUAN PING CHARLTON STEVEN C CHU AMY H EDELBROCK ANDREW J JUNG SUNG KWON HUANG DIJIA		
发明人	WU, HUAN-PING CHARLTON, STEVEN C. CHU, AMY H. EDELBROCK, ANDREW J. JUNG, SUNG-KWON HUANG, DIJIA		
IPC分类号	A61B5/00 C12Q1/00 G01N27/49 G01N33/487		
CPC分类号	A61B5/14532 A61B5/1455 A61B5/1486 A61B5/1495 C12Q1/004 G01N27/3272 C12Q1/54 G01N27/3271		
优先权	60/854060 2006-10-24 US 60/869557 2006-12-11 US 60/869625 2006-12-12 US		
其他公开文献	EP2083674A2		
外部链接	<a href="#">Espacenet</a>		

摘要(译)

生物传感器系统使用没有Cottrell衰变的电化学过程来确定生物样品的分析物浓度。生物传感器系统产生具有瞬态衰减的输出信号，其中输出信号不与时间的平方根成反比。瞬态衰减大于或小于Cottrell衰变的-0.5衰减常数。瞬时衰变可能由相对较短的温育时间，相对小的样品储存容积，电极表面与传感带盖之间的相对小的距离，和/或相对于试剂层的平均初始厚度的相对短的激发而引起。生物传感器系统根据具有瞬时衰减的输出信号确定分析物浓度。

$$i(t) = nFAc_0 \left( \frac{D}{\pi t} \right)^{1/2} = nFAc_0 \left( \frac{D}{\pi} \right)^{1/2} t^{-1/2}$$

11