

(19) World Intellectual Property
Organization
International Bureau



(43) International Publication Date
21 July 2005 (21.07.2005)

PCT

(10) International Publication Number
WO 2005/065414 A2

(51) International Patent Classification: **Not classified**

(21) International Application Number:
PCT/US2004/044054

(22) International Filing Date:
31 December 2004 (31.12.2004)

(25) Filing Language: English

(26) Publication Language: English

(30) Priority Data:
60/533,981 31 December 2003 (31.12.2003) US

(71) Applicant (for all designated States except US): **PE-
LIKAN TECHNOLOGIES, INC.** [US/US]; 1072 East
Meadow Circle, Palo Alto, CA 94303 (US).

(72) Inventors; and

(75) Inventors/Applicants (for US only): **LUM, Paul**
[US/US]; 690 Templebar Way, Los Altos, CA 94022 (US).
MAUZE, Ganapati [US/US]; 1114 Knickerbocker Drive,
Sunnyvale, CA 94087 (US). **POPLONSKI, Tomasz**
[US/US]; 1072 East Meadow Circle, Palo Alto, CA 94303
(US). **SHATSKY, Rebecca** [US/US]; 1072 East Meadow
Circle, Palo Alto, CA 94303 (US).

(74) Agent: **TUNG, Hao, Y.**; Heller Ehrman White &
Mcauliffe LLP, 275 Middlefield Road, Menlo Park, CA
94025-3506 (US).

(81) Designated States (unless otherwise indicated, for every
kind of national protection available): AE, AG, AL, AM,
AT, AU, AZ, BA, BB, BG, BR, BW, BY, BZ, CA, CH, CN,
CO, CR, CU, CZ, DE, DK, DM, DZ, EC, EE, EG, ES, FI,
GB, GD, GE, GH, GM, HR, HU, ID, IL, IN, IS, JP, KE,
KG, KP, KR, KZ, LC, LK, LR, LS, LT, LU, LV, MA, MD,
MG, MK, MN, MW, MX, MZ, NA, NI, NO, NZ, OM, PG,
PH, PL, PT, RO, RU, SC, SD, SE, SG, SK, SL, SY, TJ, TM,
TN, TR, TT, TZ, UA, UG, US, UZ, VC, VN, YU, ZA, ZM,
ZW.

(84) Designated States (unless otherwise indicated, for every
kind of regional protection available): ARIPO (BW, GH,
GM, KE, LS, MW, MZ, NA, SD, SL, SZ, TZ, UG, ZM,
ZW), Eurasian (AM, AZ, BY, KG, KZ, MD, RU, TJ, TM),
European (AT, BE, BG, CH, CY, CZ, DE, DK, EE, ES, FI,
FR, GB, GR, HU, IE, IS, IT, LT, LU, MC, NL, PL, PT, RO,
SE, SI, SK, TR), OAPI (BF, BJ, CF, CG, CI, CM, GA, GN,
GQ, GW, ML, MR, NE, SN, TD, TG).

Published:

— without international search report and to be republished
upon receipt of that report

For two-letter codes and other abbreviations, refer to the "Guid-
ance Notes on Codes and Abbreviations" appearing at the begin-
ning of each regular issue of the PCT Gazette.

(54) Title: METHOD AND APPARATUS FOR IMPROVING FLUIDIC FLOW AND SAMPLE CAPTURE

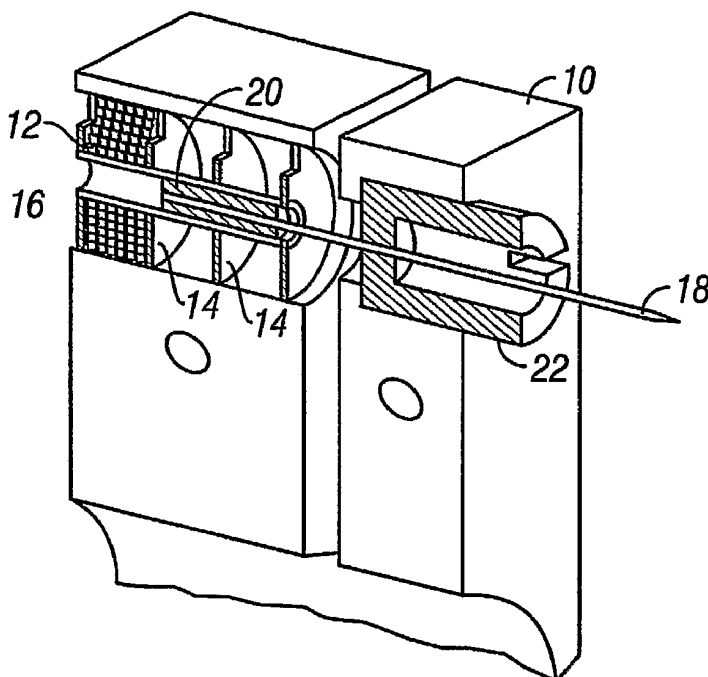

(57) Abstract: A system and method is provided for the capture of bodily fluid upon lancing of a patient. In one embodiment, the fluid sample capture aperture mesh ring is placed in the pathway of a finger penetrating member. The aperture mesh ring has a center clearance area that allows the penetrating member to pierce the skin unobstructed. The aperture mesh ring may contain a series of fluid sampling meshes as to allow the release bodily fluid to "wick" into the fluid sampling meshes for transport to the respective sensor. The invention may also relate to a method of improving the fluidic flow through a membrane mesh structure for the transportation of bodily fluids from a point of sampling to a point of measurement.

WO 2005/065414 A2

METHOD AND APPARATUS FOR IMPROVING FLUIDIC FLOW AND SAMPLE CAPTURE

5 BACKGROUND OF THE INVENTION

Field of the Invention

The invention relates to the collection of body fluid and specifically, the transfer of fluid from the tissue to a sampling device.

10 Description of Related Art

Treatment of diabetes requires frequent monitoring of levels of blood glucose. This is traditionally done in a series of steps involving the preparation of a lancing device, preparation of a glucose meter, lancing a finger, transporting the resulting blood drop to the meter, and finally obtaining a blood glucose reading.

15 Lancing devices are known in the medical health-care products industry for piercing the skin to produce blood for analysis. Biochemical analysis of blood samples is a diagnostic tool for determining clinical information. Many point-of-care tests are performed using capillary whole blood, the most common being monitoring diabetic blood glucose level. Other uses for this method include the analysis of oxygen and
20 coagulation based on Prothrombin time measurement. Typically, a drop of blood for this type of analysis is obtained by making a small incision in the fingertip, creating a small wound, which generates a small blood droplet on the surface of the skin.

Early methods of lancing included piercing or slicing the skin with a needle or razor. Current methods utilize lancing devices that contain a multitude of spring, cam and
25 mass actuators to drive the lancet. These include cantilever springs, diaphragms, coil springs, as well as gravity plumbs used to drive the lancet. Typically, the device is pre-cocked or the user cocks the device. The device is held against the skin and mechanically triggers the ballistic launch of the lancet. The forward movement and depth of skin penetration of the lancet is determined by a mechanical stop and/or dampening, as well as
30 a spring or cam to retract the lancet. Spontaneous blood droplet generation is dependent on reaching the blood capillaries and venuoles, which yield the blood sample.

As lancing devices have become more advanced, so they have become more complex, using lower and lower volumes of blood or body fluid. There may be difficulty transferring low volumes of fluid from tissue to the device.

5

SUMMARY OF THE INVENTION

The present invention provides solutions for at least some of the drawbacks discussed above. Specifically, some embodiments of the present invention provide an improved, integrated fluid sampling device. The invention relates to the problems in blood volume invariability during the post lancet wound generation and blood droplet
10 sampling. At least some of these and other objectives described herein will be met by embodiments of the present invention.

In one aspect, the present invention relates to using an electronic tissue penetration device to drive a penetrating member into tissue, sample the body fluid, and measure analyte levels in the body fluid using a sensor cartridge. The invention uses
15 various techniques to draw body fluid towards an analyte detecting device on the cartridge.

In another aspect, the present invention relates to the capture of bodily fluid immediately upon lancing. In one embodiment, the fluid sample capture aperture ring may be placed in or around the pathway of a finger penetrating member. The aperture
20 ring may have a center clearance area that allows the penetrating member to pierce the skin unobstructed. In this embodiment, the aperture ring contains a series of fluid sampling meshes as to allow the release bodily fluid to “wick” into the fluid sampling meshes for transport to the respective sensor.

One embodiment of this invention provides a solution to a problem, which
25 concerns the possible inability to guarantee a stable blood volume from a finger penetrating member wound to a sensor port located on a disposable cartridge. The problem might be due to shallowness of the penetrating member penetration depth, skin surface tension issues, or the patient’s vascular conditions resulting in the invariability in achieving an adequate blood droplet shape and size. There have been other stated
30 solutions such as the delivery of the penetrating member to the finger with a deeper penetration depth or a control method to increase the amount of blood to be produced from the wound.

In one embodiment, the present invention produces a concept of a capillary need for the blood to travel directly from the wound to the sensor port on the cartridge. Thus the volume of blood produced at the wound site irregardless of its droplet geometry can be completely transported to the analyte detecting member.

5 In another embodiment, the present invention relates to a method of improving the fluidic flow through a membrane mesh structure for the transportation of bodily fluids from a point of sampling to a point of measurement. The use of wicking structures to introduce fluids from a surface source to either a fluid transport mechanism or measurement has been used for many years. However, this invention deals with a method
10 to improve the fluid transport by decreasing the time required for transport. The method involves the proper alignment and selection of materials relative to surface energy.

In yet another embodiment, the present invention relates to the integration of an adhesive onto and within a mesh membrane for defining a fluid channel within the mesh membrane structure. In this embodiment, the adhesive is hydrophobic and upon
15 integration into the mesh, it will prohibit fluidic flow where flow is not desirable by design. The invention relates to the integration of an adhesive onto and within a mesh membrane for defining a fluid channel within the mesh membrane structure. The adhesive is hydrophobic and upon integration into the mesh, it will prohibit fluidic flow where flow is not desirable by design.

20 In another embodiment, the present invention relates to the integration of a mesh membrane sample and capture structure with a capillary transport to insure stable glucometric measurement. The structure is fundamental to an integrated sample capture, transport, and measurement device for reliable and accurate performance with very small sample volumes.

25 In a still further embodiment, the present invention relates to the integration of hydrophobic and hydrophilic adhesives onto and within a mesh membrane for the enhancement of fluidic capture and transport flow. The developed surface energy properties of specific adhesive formulations has allowed the availability of extreme hydrophobic and hydrophilic properties and various viscosities as to promote absorption
30 into the pores of the mesh membranes. Through proper mixing by design, the masking of mesh membranes has been obtainable with pressure sensitive adhesives along with fluid attractive properties to direct optimal fluid capture, transport, and flow.

In one embodiment of the present invention, a body fluid sampling device is provided for use on a patient. The device comprises a cartridge having a radial-disc shape; a plurality of penetrating members mounted on the cartridge; a sensory material on a first side of the cartridge, the sensory material sufficient for detecting at least one
5 analyte; and a wicking material positioned to substantially surround a penetrating member exit so as to acquire body fluid flowing from a wound created by the penetrating member and draw the body fluid to the sensory material.

In one embodiment, the device may include a capillary structure coupled to the wicking material, wherein the capillary structure brings the fluid to the sensory material.
10 A capillary structure may be coupled to the wicking material, the capillary structure bring the fluid to the sensory material positioned on a plurality of electrodes located in the capillary structure. A capillary structure coupled to the wicking material, wherein the capillary structure bring the fluid to the sensory material positioned on a plurality of electrodes and are in fluid communication with the capillary structure. The device may
15 include a plurality of electrodes each having the sensory material. The sensory material may be mounted on a plurality of electrode. A plurality of sets of electrodes may be associated with each penetrating member. The wicking material may optionally have a lollipop configuration. The wicking material may optionally be oriented perpendicular to a path of the penetrating member. The wicking material may be oriented to intersect a
20 path of the penetrating member. The topside connecting sections of the wicking member may comprise a PET film hydrophobic on an outer most layer and hydrophilic on an inner layer abutting against the hydrophobic double-sided adhesive layer. The bottom side sections of the wicking member may comprise a PET film hydrophilic on the inner layer abutting against the hydrophobic adhesive and hydrophobic on the outside, wherein an
25 inner fluidic channel region is a sandwich structure of top PET film / fluidic mesh structures / and bottom PET film, wherein the PET surfaces abutting the mesh structures are hydrophilic. A plurality of wicking members may be positioned in a ring configuration around the cartridge. A plurality of wicking members may be positioned in a ring configuration around the cartridge, with at least one wicking member for each
30 penetrating member in the cartridge.

In yet another embodiment of the present invention, a body fluid sampling system is provided for measuring analyte levels in the body fluid. The system comprises a

housing having a transparent window; a cartridge in said housing; a plurality of penetrating member in the cartridge; a sensory material on a first side of the cartridge, the sensory material sufficient for detecting at least one analyte; and a wicking material positioned to substantially surround a penetrating member exit so as to acquire body fluid
5 flowing from a wound created by the penetrating member. A wicking member may be coupled to each of the analyte detecting member and positioned to extend over at least a portion of a penetrating member exit chamber on the cartridge.

In yet another embodiment of the present invention, a device may be provided comprising a mesh membrane; an adhesive integrated onto and within the mesh
10 membrane for defining a fluid channel within the mesh membrane structure, wherein the adhesive is hydrophobic and upon integration into the mesh, will prohibit fluidic flow where flow is not desirable by design. The adhesive may integrate onto and within a mesh membrane for defining a fluid channel within the mesh membrane structure.

In yet another embodiment of the present invention, a device may provided
15 comprising a mesh membrane; hydrophobic and hydrophilic adhesives within the mesh membrane for the enhancement of fluidic capture and transport flow, wherein the developed surface energy properties of specific adhesive formulations has allowed the availability of extreme hydrophobic and hydrophilic properties and various viscosities as to promote absorption into the pores of the mesh membranes, creating pressure sensitive
20 adhesives along with fluid attractive properties to direct optimal fluid capture, transport, and flow.

In yet another embodiment of the present invention, an actuation device may be provided comprising a combined lancing and blood sample analysis device in a single disposable cartridge, wherein the cartridge does not have conducive leads and includes a
25 wicking material surrounding a penetrating member exit.

In yet another embodiment of the present invention, a method may be provided comprising providing a fluid sampling device comprising a cartridge, at least one penetrating member mounted on the cartridge, and a wicking material positioned to substantially surround at least one penetrating member exit on the cartridge so as to
30 acquire body fluid flowing from a wound on the patient created by actuating the penetrating member. The method may involve positioning the cartridge so that launching the penetrating member creates a wound on the patient which expresses body fluid and

using the wicking member to capture fluid expressed from the wound. The wicking member may comprise of a hydrophilic portion and a hydrophobic portion.

A further understanding of the nature and advantages of the invention will become apparent by reference to the remaining portions of the specification and drawings.

5

BRIEF DESCRIPTION OF THE DRAWINGS

Figure 1 illustrates an embodiment of a controllable force driver in the form of a cylindrical electric penetrating member driver using a coiled solenoid -type configuration.

10 Figure 2A illustrates a displacement over time profile of a penetrating member driven by a harmonic spring/mass system.

Figure 2B illustrates the velocity over time profile of a penetrating member driver by a harmonic spring/mass system.

Figure 2C illustrates a displacement over time profile of an embodiment of a controllable force driver.

15 Figure 2D illustrates a velocity over time profile of an embodiment of a controllable force driver.

Figure 3 is a diagrammatic view illustrating a controlled feed-back loop.

Figure 4 is a perspective view of a tissue penetration device having features of the invention.

20 Figure 5 is an elevation view in partial longitudinal section of the tissue penetration device of Figure 4.

Figure 6A shows one embodiment of a device which may use the present invention.

25 Figure 6B shows one embodiment of a cartridge according to the present invention.

Figure 7 is a perspective view of one embodiment with mesh on a cartridge.

Figure 8 is a view showing a penetrating member diameter.

Figure 9 shows one embodiment of the invention with a mesh with an opening for penetrating member exit.

30 Figures 10A through 10C show various embodiments of sample capture devices.

Figure 11 is a side view of a sample capture device.

Figures 12A through 12D show various embodiments of sample capture devices.

Figure 13 shows one method of manufacturing a sample capture device.

Figures 14 through 16 show other configurations of a device according to the present invention.

Figure 17 shows one method of manufacturing a sample capture device.

5 Figure 18 through 21 show configurations of sample capture devices.

DESCRIPTION OF THE SPECIFIC EMBODIMENTS

It is to be understood that both the foregoing general description and the following detailed description are exemplary and explanatory only and are not restrictive of the invention, as claimed. It may be noted that, as used in the specification and the appended
10 claims, the singular forms “a”, “an” and “the” include plural referents unless the context clearly dictates otherwise. Thus, for example, reference to “a material” may include mixtures of materials, reference to “a chamber” may include multiple chambers, and the like. References cited herein are hereby incorporated by reference in their entirety, except
15 to the extent that they conflict with teachings explicitly set forth in this specification.

In this specification and in the claims which follow, reference will be made to a number of terms which shall be defined to have the following meanings:

“Optional” or “optionally” means that the subsequently described circumstance may or may not occur, so that the description includes instances where the circumstance
20 occurs and instances where it does not. For example, if a device optionally contains a feature for analyzing a blood sample, this means that the analysis feature may or may not be present, and, thus, the description includes structures wherein a device possesses the analysis feature and structures wherein the analysis feature is not present.

The present invention may be used with a variety of different penetrating member
25 drivers. It is contemplated that these penetrating member drivers may be spring based, solenoid based, magnetic driver based, nanomuscle based, or based on any other mechanism useful in moving a penetrating member along a path into tissue. It should be noted that the present invention is not limited by the type of driver used with the penetrating member feed mechanism. One suitable penetrating member driver for use
30 with the present invention is shown in Figure 1. This is an embodiment of a solenoid type electromagnetic driver that is capable of driving an iron core or slug mounted to the penetrating member assembly using a direct current (DC) power supply. The

electromagnetic driver includes a driver coil pack that is divided into three separate coils along the path of the penetrating member, two end coils and a middle coil. Direct current is alternated to the coils to advance and retract the penetrating member. Although the driver coil pack is shown with three coils, any suitable number of coils may be used, for
5 example, 4, 5, 6, 7 or more coils may be used.

Referring to the embodiment of Figure 1, the stationary iron housing 10 may contain the driver coil pack with a first coil 12 flanked by iron spacers 14 which concentrate the magnetic flux at the inner diameter creating magnetic poles. The inner
10 insulating housing 16 isolates the penetrating member 18 and iron core 20 from the coils and provides a smooth, low friction guide surface. The penetrating member guide 22 further centers the penetrating member 18 and iron core 20. The penetrating member 18 is protracted and retracted by alternating the current between the first coil 12, the middle coil, and the third coil to attract the iron core 20. Reversing the coil sequence and
15 attracting the core and penetrating member back into the housing retracts the penetrating member. The penetrating member guide 22 also serves as a stop for the iron core 20 mounted to the penetrating member 18.

As discussed above, tissue penetration devices which employ spring or cam driving methods have a symmetrical or nearly symmetrical actuation displacement and
20 velocity profiles on the advancement and retraction of the penetrating member as shown in Figures 2 and 3. In most of the available penetrating member devices, once the launch is initiated, the stored energy determines the velocity profile until the energy is dissipated. Controlling impact, retraction velocity, and dwell time of the penetrating member within
25 the tissue can be useful in order to achieve a high success rate while accommodating variations in skin properties and minimize pain. Advantages can be achieved by taking into account of the fact that tissue dwell time is related to the amount of skin deformation as the penetrating member tries to puncture the surface of the skin and variance in skin deformation from patient to patient based on skin hydration.

In this embodiment, the ability to control velocity and depth of penetration may be achieved by use of a controllable force driver where feedback is an integral part of driver
30 control. Such drivers can control either metal or polymeric penetrating members or any other type of tissue penetration element. The dynamic control of such a driver is illustrated in Figure. 2C which illustrates an embodiment of a controlled displacement

profile and Figure 2D which illustrates an embodiment of a the controlled velocity profile. These are compared to Figures 2A and 2B, which illustrate embodiments of displacement and velocity profiles, respectively, of a harmonic spring/mass powered driver. Reduced pain can be achieved by using impact velocities of greater than about 2
5 m/s entry of a tissue penetrating element, such as a penetrating member, into tissue. Other suitable embodiments of the penetrating member driver are described in commonly assigned, copending U.S. Patent Application Ser. No. 10/127,395, (Attorney Docket No. 38187-2551) filed April 19, 2002 and previously incorporated herein.

Figure 3 illustrates the operation of a feedback loop using a processor 60. The
10 processor 60 stores profiles 62 in non-volatile memory. A user inputs information 64 about the desired circumstances or parameters for a lancing event. The processor 60 selects a driver profile 62 from a set of alternative driver profiles that have been preprogrammed in the processor 60 based on typical or desired tissue penetration device performance determined through testing at the factory or as programmed in by the
15 operator. The processor 60 may customize by either scaling or modifying the profile based on additional user input information 64. Once the processor has chosen and customized the profile, the processor 60 is ready to modulate the power from the power supply 66 to the penetrating member driver 68 through an amplifier 70. The processor 60 may measure the location of the penetrating member 72 using a position sensing
20 mechanism 74 through an analog to digital converter 76 linear encoder or other such transducer. Examples of position sensing mechanisms have been described in the embodiments above and may be found in the specification for commonly assigned, copending U.S. Patent Application Ser. No. 10/127,395, (Attorney Docket No. 38187-2551) filed April 19, 2002 and previously incorporated herein. The processor 60
25 calculates the movement of the penetrating member by comparing the actual profile of the penetrating member to the predetermined profile. The processor 60 modulates the power to the penetrating member driver 68 through a signal generator 78, which may control the amplifier 70 so that the actual velocity profile of the penetrating member does not exceed the predetermined profile by more than a preset error limit. The error limit is the
30 accuracy in the control of the penetrating member.

After the lancing event, the processor 60 can allow the user to rank the results of the lancing event. The processor 60 stores these results and constructs a database 80 for

the individual user. Using the database 79, the processor 60 calculates the profile traits such as degree of painlessness, success rate, and blood volume for various profiles 62 depending on user input information 64 to optimize the profile to the individual user for subsequent lancing cycles. These profile traits depend on the characteristic phases of penetrating member advancement and retraction. The processor 60 uses these calculations to optimize profiles 62 for each user. In addition to user input information 64, an internal clock allows storage in the database 79 of information such as the time of day to generate a time stamp for the lancing event and the time between lancing events to anticipate the user's diurnal needs. The database stores information and statistics for each user and each profile that particular user uses.

In addition to varying the profiles, the processor 60 can be used to calculate the appropriate penetrating member diameter and geometry suitable to realize the blood volume required by the user. For example, if the user requires about 1-5 microliter volume of blood, the processor 60 may select a 200 micron diameter penetrating member to achieve these results. For each class of penetrating member, both diameter and penetrating member tip geometry, is stored in the processor 60 to correspond with upper and lower limits of attainable blood volume based on the predetermined displacement and velocity profiles.

The lancing device is capable of prompting the user for information at the beginning and the end of the lancing event to more adequately suit the user. The goal is to either change to a different profile or modify an existing profile. Once the profile is set, the force driving the penetrating member is varied during advancement and retraction to follow the profile. The method of lancing using the lancing device comprises selecting a profile, lancing according to the selected profile, determining lancing profile traits for each characteristic phase of the lancing cycle, and optimizing profile traits for subsequent lancing events.

Figure 4 illustrates an embodiment of a tissue penetration device, more specifically, a lancing device 80 that includes a controllable driver 179 coupled to a tissue penetration element. The lancing device 80 has a proximal end 81 and a distal end 82. At the distal end 82 is the tissue penetration element in the form of a penetrating member 83, which is coupled to an elongate coupler shaft 84 by a drive coupler 85. The elongate coupler shaft 84 has a proximal end 86 and a distal end 87. A driver coil pack 88 is

disposed about the elongate coupler shaft 84 proximal of the penetrating member 83. A position sensor 91 is disposed about a proximal portion 92 of the elongate coupler shaft 84 and an electrical conductor 94 electrically couples a processor 93 to the position sensor 91. The elongate coupler shaft 84 driven by the driver coil pack 88 controlled by the position sensor 91 and processor 93 form the controllable driver, specifically, a controllable electromagnetic driver.

Referring to Figure 5, the lancing device 80 can be seen in more detail, in partial longitudinal section. The penetrating member 83 has a proximal end 95 and a distal end 96 with a sharpened point at the distal end 96 of the penetrating member 83 and a drive head 98 disposed at the proximal end 95 of the penetrating member 83. A penetrating member shaft 201 is disposed between the drive head 98 and the sharpened point 97. The penetrating member shaft 201 may be comprised of stainless steel, or any other suitable material or alloy and have a transverse dimension of about 0.1 to about 0.4 mm. The penetrating member shaft may have a length of about 3 mm to about 50 mm, specifically, about 15 mm to about 20 mm. The drive head 98 of the penetrating member 83 is an enlarged portion having a transverse dimension greater than a transverse dimension of the penetrating member shaft 201 distal of the drive head 98. This configuration allows the drive head 98 to be mechanically captured by the drive coupler 85. The drive head 98 may have a transverse dimension of about 0.5 to about 2 mm.

A magnetic member 102 is secured to the elongate coupler shaft 84 proximal of the drive coupler 85 on a distal portion 203 of the elongate coupler shaft 84. The magnetic member 102 is a substantially cylindrical piece of magnetic material having an axial lumen 204 extending the length of the magnetic member 102. The magnetic member 102 has an outer transverse dimension that allows the magnetic member 102 to slide easily within an axial lumen 105 of a low friction, possibly lubricious, polymer guide tube 105' disposed within the driver coil pack 88. The magnetic member 102 may have an outer transverse dimension of about 1.0 to about 5.0 mm, specifically, about 2.3 to about 2.5 mm. The magnetic member 102 may have a length of about 3.0 to about 5.0 mm, specifically, about 4.7 to about 4.9 mm. The magnetic member 102 can be made from a variety of magnetic materials including ferrous metals such as ferrous steel, iron, ferrite, or the like. The magnetic member 102 may be secured to the distal portion 203 of

the elongate coupler shaft 84 by a variety of methods including adhesive or epoxy bonding, welding, crimping or any other suitable method.

Proximal of the magnetic member 102, an optical encoder flag 206 is secured to the elongate coupler shaft 84. The optical encoder flag 206 is configured to move within a slot 107 in the position sensor 91. The slot 107 of the position sensor 91 is formed between a first body portion 108 and a second body portion 109 of the position sensor 91. The slot 107 may have separation width of about 1.5 to about 2.0 mm. The optical encoder flag 206 can have a length of about 14 to about 18 mm, a width of about 3 to about 5 mm and a thickness of about 0.04 to about 0.06 mm.

The optical encoder flag 206 interacts with various optical beams generated by LEDs disposed on or in the position sensor body portions 108 and 109 in a predetermined manner. The interaction of the optical beams generated by the LEDs of the position sensor 91 generates a signal that indicates the longitudinal position of the optical flag 206 relative to the position sensor 91 with a substantially high degree of resolution. The resolution of the position sensor 91 may be about 200 to about 400 cycles per inch, specifically, about 350 to about 370 cycles per inch. The position sensor 91 may have a speed response time (position/time resolution) of 0 to about 120,000 Hz, where one dark and light stripe of the flag constitutes one Hertz, or cycle per second. The position of the optical encoder flag 206 relative to the magnetic member 102, driver coil pack 88 and position sensor 91 is such that the optical encoder 91 can provide precise positional information about the penetrating member 83 over the entire length of the penetrating member's power stroke.

An optical encoder that is suitable for the position sensor 91 is a linear optical incremental encoder, model HEDS 9200, manufactured by Agilent Technologies. The model HEDS 9200 may have a length of about 20 to about 30 mm, a width of about 8 to about 12 mm, and a height of about 9 to about 11 mm. Although the position sensor 91 illustrated is a linear optical incremental encoder, other suitable position sensor embodiments could be used, provided they possess the requisite positional resolution and time response. The HEDS 9200 is a two channel device where the channels are 90 degrees out of phase with each other. This results in a resolution of four times the basic cycle of the flag. These quadrature outputs make it possible for the processor to determine the direction of penetrating member travel. Other suitable position sensors include

capacitive encoders, analog reflective sensors, such as the reflective position sensor discussed above, and the like.

A coupler shaft guide 111 is disposed towards the proximal end 81 of the lancing device 80. The guide 111 has a guide lumen 112 disposed in the guide 111 to slidingly
5 accept the proximal portion 92 of the elongate coupler shaft 84. The guide 111 keeps the elongate coupler shaft 84 centered horizontally and vertically in the slot 102 of the optical encoder 91.

The driver coil pack 88, position sensor 91 and coupler shaft guide 111 are all secured to a base 113. The base 113 is longitudinally coextensive with the driver coil
10 pack 88, position sensor 91 and coupler shaft guide 111. The base 113 can take the form of a rectangular piece of metal or polymer, or may be a more elaborate housing with recesses, which are configured to accept the various components of the lancing device 80.

As discussed above, the magnetic member 102 is configured to slide within an axial lumen 105 of the driver coil pack 88. The driver coil pack 88 includes a most distal
15 first coil 114, a second coil 115, which is axially disposed between the first coil 114 and a third coil 116, and a proximal-most fourth coil 117. Each of the first coil 114, second coil 115, third coil 116 and fourth coil 117 has an axial lumen. The axial lumens of the first through fourth coils are configured to be coaxial with the axial lumens of the other coils and together form the axial lumen 105 of the driver coil pack 88 as a whole. Axially
20 adjacent each of the coils 114-117 is a magnetic disc or washer 118 that augments completion of the magnetic circuit of the coils 114-117 during a lancing cycle of the device 80. The magnetic washers 118 of the embodiment of Figure 5 are made of ferrous steel but could be made of any other suitable magnetic material, such as iron or ferrite. The outer shell 89 of the driver coil pack 88 is also made of iron or steel to complete the
25 magnetic path around the coils and between the washers 118. The magnetic washers 118 have an outer diameter commensurate with an outer diameter of the driver coil pack 88 of about 4.0 to about 8.0 mm. The magnetic washers 118 have an axial thickness of about 0.05, to about 0.4 mm, specifically, about 0.15 to about 0.25 mm.

Wrapping or winding an elongate electrical conductor 121 about an axial lumen
30 until a sufficient number of windings have been achieved forms the coils 114-117. The elongate electrical conductor 121 is generally an insulated solid copper wire with a small outer transverse dimension of about 0.06 mm to about 0.88 mm, specifically, about 0.3

mm to about 0.5 mm. In one embodiment, 32 gauge copper wire is used for the coils 114-117. The number of windings for each of the coils 114-117 of the driver pack 88 may vary with the size of the coil, but for some embodiments each coil 114-117 may have about 30 to about 80 turns, specifically, about 50 to about 60 turns. Each coil 114-117
5 can have an axial length of about 1.0 to about 3.0 mm, specifically, about 1.8 to about 2.0 mm. Each coil 114-117 can have an outer transverse dimension or diameter of about 4.0, to about 2.0 mm, specifically, about 9.0 to about 12.0 mm. The axial lumen 105 can have a transverse dimension of about 1.0 to about 3.0 mm.

It may be advantageous in some driver coil 88 embodiments to replace one or
10 more of the coils with permanent magnets, which produce a magnetic field similar to that of the coils when the coils are activated. In particular, it may be desirable in some embodiments to replace the second coil 115, the third coil 116 or both with permanent magnets. In addition, it may be advantageous to position a permanent magnet at or near the proximal end of the coil driver pack in order to provide fixed magnet zeroing function
15 for the magnetic member (Adams magnetic Products 23A0002 flexible magnet material (800) 747-7543).

Referring now to Figures 6A and 6B, yet another embodiment of the present invention will now be described. It should be understood that this embodiment may be adapted for use with devices described in commonly assigned copending U.S. Patent
20 Applications Ser. No. 10/323,624 (Attorney Docket No. 38187-2608) filed December 18, 2002. Figure 6A shows a device that may optionally use a cartridge as shown in Figure 6B. Figure 6B shows a radial cartridge 220. The cartridge 220 may optionally include a sterility barrier 232 and a substrate 250 having a plurality of analyte detecting members 226. In this embodiment, the cartridge 220 is designed so that blood will enter the fluid
25 chamber 228 and be held there for analysis.

Figure 6B shows the radial cartridge 220 may optionally be used with a lancing device 230. The radial cartridge 220 may optionally be sealed with a sterility barrier 232 and be coupled to analyte detecting members mounted on a substrate 234. A suitable device is described in commonly assigned, copending U.S. Patent Application No.
30 10/429,196 (Attorney Docket No. 38187-2662) fully incorporated herein by reference for all purposes.

It should be understood that in some embodiments, the layer 234 may be removed and the bottom layer of the cartridge 220 sealed. Instead, a ring 252 with a plurality of analyte detecting members 254 (such as those shown in Figures 10A-20) may optionally be in a ring configuration around the penetrating member cartridge 220. This orients one
5 analyte detecting member 254 for each penetrating member in cartridge 220. Some embodiments may optionally have portions of the ring 254 fold underneath the cartridge 220 as shown in Figures 14 and 15.

Referring now to Figure 7, as described above, when a penetrating member 340 is actuated and extends outward from the cartridge 220, the mesh 320 may optionally be
10 pushed aside or pierced by the exiting member 340. The resulting ring of capillary fibers 342 around the wound channel would be available after the penetrating member was retracted to wick the blood sample into the sample channel.

The physical characteristics of the mesh 320 is one aspect for successfully transport of blood to the analyte detecting member 250. In one embodiment, the mesh
15 320 may be pliable enough to allow relaxation, but maintain contact or near-contact with the skin surface. An active region could be striped on the mesh to allow the blood to only travel in the direction towards the analyte detecting member. A different gauge capillary fiber may optionally be used on the mains versus the cross. In another embodiment, the mains may optionally have a smaller gauge and higher pitch to promote vertical
20 movement. As an additional benefit, if the mesh assisted in distributing the force of penetrating member impact with the skin, the cutting efficiency of the penetrating member could be increased.

In another embodiment, the mesh 320 would reduce the amount of micropositioning used to assure that the droplet of body fluid gets to the analyte detecting
25 member. The potential volume required by the analyte detecting member could be reduced by reducing the amount of blood or body fluid that spontaneously rises to the surface of the skin that is either not removed from the skin once the surface tension is released in a traditional, microfluidics methods. Traditional microfluidics could also have a higher volume required to get the blood to the sample chamber.

30 Referring now to Figure 8, this embodiment of the present invention pertains to the 100 percent capture of a bodily fluid generated from a wound upon lancing. There are problems when the blood droplet formed immediately after lancing. The droplet can be

positioned in any position 360 degrees along the circumference of the lancing location. Due to the observed low jitter or lateral movement of the penetrating member during the lancing protocol, the fluidic sample capture aperture with mesh will not obstruct the path of the penetrating member. The model of the penetrating member and subsequent droplet formation has provided a geometric dimension that will allow the fluidic sample capture and transport structure to be constructed circumnavigating the entire penetrating member. This penetrating member circumnavigating sample and capture mesh structure will allow the capture of a produced droplet and transport it directly to the sensor measurement devices.

10 As seen in Figure 8, the drawing shows a calculation of the aperture opening based upon the penetrating member 340 diameter and both the observed and specified penetrating member lateral motion resolution. In addition, the aperture ring contains a collection of fluid channels, with respect to this particular disclosure, the mesh is to transport the captured bodily fluid to the measurement sensors which also circumnavigate the aperture opening.

15 This embodiment of the invention provides a sample, capture, and transport solution to that of an integrated physiological measurement device, which allows the capture of the fluidic sample by mesh immediately upon the penetrating member operation. As seen in Figure 9, the structure contains an aperture ring structure 360, which surrounds or circumnavigates the penetrating member wound. Upon the release of the bodily fluid from the penetrating member wound, the bodily fluid droplet grows until comes in contact with a portion of the fluid transporting mesh 360. Upon contact with the fluid mesh, the bodily fluid through capillary action is wicked into the capillary mesh and brought forth to the sensors also contained in the aperture ring structure. In one embodiment, the mesh 360 takes the blood and distributes it over a uniform surface. There is insignificant amount of sucking, pumping, or capillary force. In one embodiment, the mesh 360 spread the blood until the fluid contacts a capillary channel and at that point, the pulling and sucking begins. This is step one spreading. Step two is a partial capillary or some pumping or sucking action (this is the pumping action since there are side walls that are now pulling). Step 3 is taking through a 90 degree bend to bring the fluid to the analyte detecting member.

20

25

30

Figure 10A shows a close up of a portion of the mesh. Figure 10B shows that grooves or gratings 362 may also be used to serve the spreading function described. Such grooves may optionally be pressed and create striations on a plastic surface. It is creating a fine textured surface to distribute fluid. Figure 10C shows the scoring or grooves used to spread the materials.

The mesh 360 or the gratings serves as the initial capture up front, which direct blood to a capillary channel. It is also desirable in some embodiments to transport the blood quickly, hence it is desirable to engage the blood in whatever orientation it may be coming off of the penetrating member. Mesh also displaces volume and thus it will use a lower volume of blood during transport. Single and double meshes can be used. In the present invention, since this is an integrated device, the user is blind as to where the blood droplet is on the penetrating member. It can be in a variety of orientations and the present mesh 360 that surrounds the exit port will capture the blood and lead it to transport. Irregardless of where the blood droplet is, it will be transported. In one embodiment, it takes less than 10 seconds to transport blood to the analyte detecting member. In one embodiment, it takes less than 5 seconds to transport blood to the analyte detecting member.

Figure 11 shows that the blood coming out will contact a mesh 360, regardless of the orientation of the blood on the penetrating member. This surrounding mesh helps to ensure capture.

Referring now to Figures 12A-12C, the drawings shown describe several configurations, of which there are three, built and tested. The structure in Figure 12A is one embodiment with a cross section of a fluidic structure 380 with a channel totally free of adhesives. The topside connecting sections comprise of a PET film hydrophobic on the outer most layer 382 and hydrophilic on the inner layer 384 abutting against the hydrophobic double-sided adhesive layer 386. The bottom side would comprise of a PET film hydrophilic on the inner layer abutting against the hydrophobic adhesive and hydrophobic on the outside. The inner fluidic channel region would be a sandwich structure of top PET film / fluidic mesh structures / and bottom PET film. The PET surfaces abutting the mesh structures would be hydrophilic.

The structure in Figure 12B is a cross section of a fluidic structure with a channel free of adhesives. The structure 390 is very similar to the structure previously described.

However, the difference is in the surface energy of the top and bottom PET films. The hydrophobic surface 392 and hydrophilic surfaces 394 are reversed such that the outer surface is hydrophilic and the inner surface abutting either the adhesive layer or mesh is hydrophobic. The fluidic channel regions remain free of adhesive.

5 The structure in Figure 12C is a cross section of a fluidic structure with a channel totally free of adhesives. The structure is very similar to the first structure previously described. However, this structure also incorporates a fluid entry port 396 of which the surface directly facing the droplet of fluid has been slightly oversized in order to expose additional mesh material. There exist a smaller hole on one PET film surface which
10 matches the hole size of the mesh and a larger dissimilar hole on the opposite sandwiching PET film surface.

Figure 12D shows a front view of the embodiment of Figure 12C. The blood will be spread and then pulled in the direction indicating by arrows 400. Some embodiments may optionally have a tapered configuration (shown by phantom line 402) and facilitates
15 flow around a 90 degree bend. The taper accounts for bulging or bunch of materials when the neck is bent, which narrows the effective channel available for fluid flow.

These embodiments of this invention entail a method of improving fluidic flow through fluidic mesh transport structures by moderating the selection of hydrophobicity or hydrophilicity through surface energy. This method of moderating or modifying
20 surface energies can be done through a number of different means known to those practicing the arts.

There are a number of options that can be used to treat surfaces to obtain a particular surface preference for degree of hydrophilic or hydrophobic. The concerns relating to the selection of the preferred method of treating a surface depends upon the
25 window of need for this respective treatment. If the window of preference were for a reliable long-term state, then the method may dictate that the bulk properties of the structured material or a physical coating that has good longevity be selected. If the window of preference were to be a short-term state, such as that used in the application of an adhesive, then the method of only treating the surface will be preferred.

30 The metrology for determining the state of the surface is usually the measurement of the contact angle of a small liquid standard and the material relative to ambient air. The

measurement and monitoring of this contact angle and surface energy of time is critical in determining the relative effectiveness of the surface state treatment or bulk fabrication.

The methods of treatment are but are not limited to:

- 5 a). The fabrication with a natural bulk material used to determine the material's bulk surface properties and the entire process used to fabricate the material. An example of this would be the treatment of PET (Poly(ethylene terephthalate)) or raw polyester.
- b). The design of the material's surface texture pattern by fabrication processes in conjunction with the material's natural bulk properties. Physical molding or mechanical machining processes may accomplish this. An example of this would be the modification
10 of Young's equation presented later in this discussion.
- c). The use of high energy sources such plasmas, ion guns, and sputtering techniques to either texture or modify the surface molecular structure. This would include vacuum ion milling, vacuum or argon plasmas, or atmospheric plasmas or corona processes. An example of this would be Argon plasma, Oxygen plasma, ion milling, or
15 Tantec corona treatments.
- d). The use of wet chemicals to etch and texture the surface molecular structure. An example of this would be Tetra-Etch.
- e). The use of thin polymer films deposited by physical vacuum methodologies, spin on coatings, vapor deposited methods, or wet deposited then activated via photonic
20 treatments to actively link molecules of choice for the surface. An example of this would be films by Surmodics.
- f). The use by design and selection of membrane structures that require the insert or adhesion of films on to surfaces as to create the actual fluid conduction path. An example of this would be membrane films offered by Millipore or paper films offered by
25 Scheicher & Schuell or Sefar America.

A Brief Discussion On Surface Energy of Polymers

Wettability and repellency of polymers against water are basic surface properties of the polymers. Hydrophilic and hydrophobic surfaces are results of interactions at an interface between polymer and water layers and closely related to the surface energy of
30 the polymers. Hydrophilic surface means strong interactions with water, and polar groups have to exist at the surface of the polymer. As a result, the contact angle of the polymer against water is small. If the surface energy of the polymer is more than that of water

(72.8 mJ/N), the surface of the polymer will contact immediately with water, and the contact angle will be zero. A hydrophobic surface means weak interactions with water at an interface, and the surface consists mainly of nonpolar groups. The contact angle of the polymer against water is as large as 90 degrees, in some cases more than 100 degrees.

5 The surface energy of a material is the excess energy per unit area due to the existence of the free surface. In liquids, the surface energy is conventionally called surface tension. When two different surfaces contact each other and the two surfaces are not mixed, the contact produces an interface and the excess energy is generated at the interface by the formation of the interface. The excess energy per unit area is called
10 interfacial energy or interfacial tension. The contact angle of the polymer against water is a balance among the surface energy of the polymer (γ_s) and of water (γ_l) and the interfacial energy (γ_{sl}).

The balance of the equation is written $\gamma_l \cos \theta = \gamma_s - \gamma_{sl}$

15 Therefore, the higher the surface energy of the polymer is and the lower the interfacial energy is, the lower the contact angle is. In the extreme case that γ_s is equal to γ_l and γ_{sl} is zero, the contact angle becomes zero, and complete wetting is accomplished.

The surface energy of the polymer defined by the excess energy per unit area due to the existence of the free surface is closely related to cohesive energy density of the
20 polymer chains. Three methods are proposed for estimation of the surface energy of polymers:

1). The method from the contact angles of polymer against different liquids using
$$\gamma_s = \gamma_l (1 + \cos \theta)^2 / (4 \phi^2)$$

$$\phi = (4(V_s V_l)^{1/3}) / ((V_s^{1/3}) + (V_l^{1/3}))^2$$

25 where V_s and V_l are molar volumes of the polymer and the liquid, respectively.

2). The method from the Zisman plot - theoretically, the estimated value is not the real surface energy value

3). The method from the surface tension of melted polymers.

30 The above discussions provide the basis and foundation of how surface energy on films and meshes can be both moderated and measured. The structures in this invention disclosure concern the creation of circular or rectangular tubular structures and how the fluidic flow might be moderated or enhanced by the use of surfaces modified or

moderated by the fore mentioned techniques. The three structures were fabricated and tested. However, the last structure or bottom structure provided the best wicking and attraction of fluid to the structure surface and transport into the fluid channel. The combination of the hydrophilic surfaces abutting the hydrophilic mesh for both sides of the fluidic channel and the dissimilar hole sizes exposing the hydrophilic mesh against a hydrophilic surface demonstrated excellent fluidic action. Wicking action upon the exposed hydrophilic mesh and combined hydrophilic surface and support structure promoted immediate surface action. The combined hydrophilic channel top and bottom walls along with the capillary action of the hydrophilic mesh supported immediate fluid transport from source to destination.

Referring now to Figure 13, the drawings show a step by step description of the fabrication of one embodiment of an integrated mesh and adhesive structure. The layer by layer assembly is described in the drawings. Another figure at the bottom shows the final assembly of the structure. This invention pertains to the design and fabrication of mesh structures as a method of sample, capture, and transport of bodily fluids. The traditional methods of pattern definition in mesh membrane structures has been to either but and fit the mesh within a predefined physical capillary structure or the impregnating the mesh membrane pores by the process of screen printing.

The process of screen printing involves the use of many different chemicals, light energies, or vapors that might alter the chemistry of the mesh membrane surface chemistry or physics. Thus the use of a prefabricated, preformed, and preprocessed pressure sensitive adhesive to be pressed into the mesh might be the most optimal application for mesh membrane surfaces that are used in medical diagnostics.

Figure 13 shows one embodiment with a liners 420, an adhesive 422, and another liner 424. Mesh 426 is compressed into adhesive 428. A combination of mesh and adhesive is shown on top of liner. This embodiment of the invention adheres to the principal of using hydrophilic/hydrophobic surface tension. In some embodiment, the adhesives are used to define the channels. Both adhesives are hydrophobic to minimize delamination of the films. The adhesives may optionally be die cut to shape. This facilitates integration of manufacturing. The devices may optionally be hybrid structures using wicking material for capture and then a capillary structure for transport. The mesh leads a little into the capillary and then the fluid just flows. Figure 14 shows such a mesh

360 leading partially into a capillary structure 408. Figure 15 shows a side view with the electrodes 226 located over capillary structure 408. This an L-shaped configuration. Some embodiments may not have a L-bend and may be linear configuration that is vertical as indicated by phantom lines 440. Figure 15 also shows that the wicking member is oriented to be perpendicular to the path of the penetrating member indicated by arrow 361. The wicking member is oriented to intersect the path of the penetrating member indicated by arrow 361.

Referring now to Figure 16, the drawing shows a schematic top and side view depicting the integrated mesh membrane and capillary structure. This embodiment of the invention relates to the integration of a mesh membrane sample and capture structure with a capillary transport to insure stable glucometric measurement. The structure is useful to an integrated sample capture, transport, and measurement device for reliable and accurate performance with very small sample volumes.

This embodiment of the invention pertains to the design and development of a blood droplet sample capture, blood fluid transport, and delivery onto a glucose measurement device. The sample and capture mesh membrane mechanism guarantees consistent capture of a droplet after a penetrating member procedure. The resulting blood droplet from the digit tip is captured by the mesh membrane structure 360 and transported via the mesh membrane mechanism into a small capillary structure 408 consisting of the prior membrane structure less the mesh membrane onto the surface of the glucose measurement device. The height of this cavity for the measurement structure is established by the electrochemistry limitations of the glucose measurement chemistry. The height specified is known to those practicing the arts. This structure will allow certain sample capture, rapid transport, and reliable measurement. In an electrochemical setup, the electrodes (either a 2 electrode setup or a 3 electrode setup) will be positioned to sample body fluid in the capillary structure area 408.

Referring now to Figure 17, the drawing shows a step by step description of one embodiment for the fabrication of an integrated mesh and adhesive structure. It should be noted that the additional layer of a hydrophilic adhesive layer at the bottom of the mesh membrane provides an excellent sample capture surface within the fluid channel and at the same time augmenting the channel sealing and definition at non fluidic flow regions by design. Figure 17 shows a hydrophobic adhesive layer 450 between two liners. The

device may also have a mesh layer 454. There may optionally be a hydrophilic adhesive layer 456. After assembly, the device will have fluid channels 460 and non-channel regions 462.

This embodiment of the present invention relates to the integration of hydrophobic and hydrophilic adhesives onto and within a mesh membrane for the enhancement of fluidic capture and transport flow. The developed surface energy properties of specific adhesive formulations has allowed the availability of extreme hydrophobic and hydrophilic properties and various viscosities as to promote absorption into the pores of the mesh membranes. Through proper mixing by design, the masking of mesh membranes has been obtainable with pressure sensitive adhesives along with fluid attractive properties to direct optimal fluid capture, transport, and flow.

This embodiment of the present invention may also pertain to the design and fabrication of mesh structures as a method of sample, capture, and transport of bodily fluids. The traditional methods of pattern definition in mesh membrane structures has been to either but and fit the mesh within a predefined physical capillary structure or the impregnating the mesh membrane pores by the process of screen printing.

The process of screen printing involves the use of many different chemicals, light energies, or vapors that might alter the chemistry of the mesh membrane surface chemistry or physics. Thus the use of a prefabricated, preformed, and preprocessed pressure sensitive adhesive to be pressed into the mesh might be the most optimal application for mesh membrane surfaces that are used in medical diagnostics.

The uniqueness of this embodiment of the invention is the further integration of a selective layer of hydrophilic adhesive onto the mesh membrane fluid channel structure to serve a dual purpose of sealing the fluid channel structure from lateral flow leaks and at the same time serve as an enhancement surface for the fluid and transport channel structure.

Referring now to Figure 18 a still further embodiment of the present invention shows that the wicking material may optionally be designed to have flaps which only substantially surround the penetrating member exit but will still engage blood or other body fluid flowing from the wound. Other geometries are shown in Figures 19-21. Figure 19 shows one embodiment with four rectangular tabs 502. Figure 20 shows an embodiment with four triangular tabs 504. Figure 21 shows an embodiment with three

rectangular tabs 506. These tabs are positioned to contact body fluid that may be expressed from a wound on the patient. It should be understood that a variety of other shapes, combinations of shapes, combination of shapes described above, and/or other configurations may be used so long as the substantially ensure the blood coming from any orientation from the penetrating member wound will be captured. Some embodiments may simply have a round opening without the tabs. Other shaped openings such as square, rectangular, oval, triangular, octagonal, polygonal, or combinations of any of the above are possible.

While the invention has been described and illustrated with reference to certain particular embodiments thereof, those skilled in the art will appreciate that various adaptations, changes, modifications, substitutions, deletions, or additions of procedures and protocols may be made without departing from the spirit and scope of the invention. For example, with any of the above embodiments, the location of the penetrating member drive device may be varied, relative to the penetrating members or the cartridge. With any of the above embodiments, the penetrating member tips may be uncovered during actuation (i.e. penetrating members do not pierce the penetrating member enclosure or protective foil during launch). With any of the above embodiments, the penetrating members may be a bare penetrating member during launch. With any of the above embodiments, the penetrating members may be bare penetrating members prior to launch as this may allow for significantly tighter densities of penetrating members. In some embodiments, the penetrating members may be bent, curved, textured, shaped, or otherwise treated at a proximal end or area to facilitate handling by an actuator. The penetrating member may be configured to have a notch or groove to facilitate coupling to a gripper. The notch or groove may be formed along an elongate portion of the penetrating member. With any of the above embodiments, the cavity may be on the bottom or the top of the cartridge, with the gripper on the other side. In some embodiments, analyte detecting members may be printed on the top, bottom, or side of the cavities. The front end of the cartridge maybe in contact with a user during lancing. The same driver may be used for advancing and retraction of the penetrating member. The penetrating member may have a diameters and length suitable for obtaining the blood volumes described herein. The penetrating member driver may also be in substantially the same plane as the cartridge. In some embodiments, one pin may be configured to

contact more than one electrode (such as a U-shaped pin that contacts both the counter and reference electrodes). The driver may use a through hole or other opening to engage a proximal end of a penetrating member to actuate the penetrating member along a path into and out of the tissue. With any of the above embodiments, the strips may have
5 rectangular configurations instead of the lollipop configuration such as that shown in Figure 12D. It should be understood that any of the inventions herein may be used in conjunction or adapted for use with devices disclosed in U.S. Patent Applications Attorney Docket No. 38187-2551, 38187-2608, and 38187-2662. This includes but is not
10 limited to integration of various wicking materials, capillary structures, combinations of the above, or the like with a radial cartridge as described in 38187-2662. The present application is related to US Provisional Application Ser. No. 60/533,981 (Attorney Docket no. 38187-2723).

The publications discussed or cited herein are provided solely for their disclosure prior to the filing date of the present application. Nothing herein is to be construed as an
15 admission that the present invention is not entitled to antedate such publication by virtue of prior invention. Further, the dates of publication provided may be different from the actual publication dates which may need to be independently confirmed. All publications, patents, and patent applications mentioned herein are incorporated herein by reference to disclose and describe the structures and/or methods in connection with which
20 the publications are cited.

Where a range of values is provided, it is understood that each intervening value, to the tenth of the unit of the lower limit unless the context clearly dictates otherwise, between the upper and lower limit of that range and any other stated or intervening value in that stated range is encompassed within the invention. The upper and lower limits of
25 these smaller ranges may independently be included in the smaller ranges is also encompassed within the invention, subject to any specifically excluded limit in the stated range. Where the stated range includes one or both of the limits, ranges excluding either both of those included limits are also included in the invention.

Expected variations or differences in the results are contemplated in accordance
30 with the objects and practices of the present invention. It is intended, therefore, that the invention be defined by the scope of the claims which follow and that such claims be interpreted as broadly as is reasonable.

WHAT IS CLAIMED IS:

- 1 1. A body fluid sampling device for use on a patient, the device
2 comprising:
3 a cartridge;
4 at least one penetrating member mounted on the cartridge; and
5 a wicking material positioned to substantially surround at least one
6 penetrating member exit on the cartridge so as to acquire body fluid flowing from a
7 wound on the patient created by actuating the penetrating member.
- 1 2. A body fluid sampling device for use on a patient, the device
2 comprising:
3 a cartridge having a radial-disc shape;
4 a plurality of penetrating members mounted on said cartridge;
5 a sensory material on a first side of said cartridge, said sensory material
6 sufficient for detecting at least one analyte; and
7 a wicking material positioned to substantially surround a penetrating
8 member exit so as to acquire body fluid flowing from a wound created by the penetrating
9 member and draw the body fluid to the sensory material.
- 1 3. The device of claim 1 further comprising a capillary structure
2 coupled to the wicking material, said capillary structure bring said fluid to the sensory
3 material.
- 1 4. The device of claim 1 further comprising a capillary structure
2 coupled to the wicking material, said capillary structure bring said fluid to the sensory
3 material positioned on a plurality of electrodes located in the capillary structure.
- 1 5. The device of claim 1 further comprising a capillary structure
2 coupled to the wicking material, said capillary structure bring said fluid to the sensory
3 material positioned on a plurality of electrodes and are in fluid communication with the
4 capillary structure.
- 1 6. The device of claim 1 further comprising a plurality of electrodes
2 each having said sensory material.

1 7. The device of claim 1 wherein the sensory material is mounted on a
2 plurality of electrode.

1 8. The device of claim 1 a plurality of sets of electrodes are associated
2 with each penetrating member.

1 9. The device of claim 1 wherein the wicking material has a lollipop
2 configuration.

1 10. The device of claim 1 wherein the wicking material is oriented
2 perpendicular to a path of the penetrating member.

1 11. The device of claim 1 wherein the wicking material is oriented to
2 intersect a path of the penetrating member.

1 12. The device of claim 1 wherein topside connecting sections of the
2 wicking member comprises a PET film hydrophobic on an outer most layer and
3 hydrophilic on an inner layer abutting against the hydrophobic double-sided adhesive
4 layer.

1 13. The device of claim 1 wherein bottom side sections of the wicking
2 member comprises a PET film hydrophilic on the inner layer abutting against the
3 hydrophobic adhesive and hydrophobic on the outside, wherein an inner fluidic channel
4 region is a sandwich structure of top PET film / fluidic mesh structures / and bottom PET
5 film, wherein the PET surfaces abutting the mesh structures are hydrophilic.

1 14. The device of claim 1 wherein a plurality of wicking members are
2 positioned in a ring configuration around the cartridge.

1 15. The device of claim 1 wherein a plurality of wicking members are
2 positioned in a ring configuration around the cartridge, with at least one wicking member
3 for each penetrating member in the cartridge.

1 16. A body fluid sampling system for measuring analyte levels in the
2 body fluid, said system comprising:

3 a housing having a transparent window;

4 a cartridge in said housing;

5 a plurality of penetrating member in said cartridge;
6 a sensory material on a first side of said cartridge, said sensory material
7 sufficient for detecting at least one analyte;
8 a wicking material positioned to substantially surround a penetrating
9 member exit so as to acquire body fluid flowing from a wound created by the penetrating
10 member.

1 17. The system of claim 16 wherein a wicking member is coupled to
2 each of said analyte detecting member and positioned to extend over at least a portion of a
3 penetrating member exit chamber on said cartridge.

1 18. A device comprising:
2 a mesh membrane;
3 an adhesive integrated onto and within the mesh membrane for defining a
4 fluid channel within the mesh membrane structure, wherein the adhesive is hydrophobic
5 and upon integration into the mesh, will prohibit fluidic flow where flow is not desirable
6 by design;
7 wherein the adhesive integrate onto and within a mesh membrane for
8 defining a fluid channel within the mesh membrane structure.

1 19. A device comprising:
2 a mesh membrane;
3 hydrophobic and hydrophilic adhesives within the mesh membrane for the
4 enhancement of fluidic capture and transport flow, wherein the developed surface energy
5 properties of specific adhesive formulations has allowed the availability of extreme
6 hydrophobic and hydrophilic properties and various viscosities as to promote absorption
7 into the pores of the mesh membranes, creating pressure sensitive adhesives along with
8 fluid attractive properties to direct optimal fluid capture, transport, and flow.

1 20. An actuation device comprising:
2 a combined lancing and blood sample analysis device in a single
3 disposable cartridge, said cartridge does not have conducive leads and includes a wicking
4 material surrounding a penetrating member exit.

1 21. A method comprising:

2 providing a fluid sampling device comprising a cartridge, at least one
3 penetrating member mounted on the cartridge, and a wicking material positioned to
4 substantially surround at least one penetrating member exit on said cartridge so as to
5 acquire body fluid flowing from a wound on the patient created by actuating the
6 penetrating member;

7 positioning the cartridge so that launching the penetrating member creates
8 a wound on the patient which expresses body fluid;

9 using the wicking member to capture fluid expressed from the wound.

1 22. The method of claim 21 wherein the wicking member comprises of
2 a hydrophilic portion and a hydrophobic portion.

1 23. The method of claim 21 wherein a plurality of wicking members
2 are used, each associated with at least one penetrating member and each of the wicking
3 members having a lollipop configuration.

1 24. The method of claim 21 wherein the wicking member is coupled to
2 each of said analyte detecting member and positioned to extend over at least a portion of a
3 penetrating member exit chamber on said cartridge.

1 25. The method of claim 21 further comprising a capillary structure
2 coupled to the wicking material, said capillary structure bring said fluid to the sensory
3 material.

1 26. The method of claim 21 further comprising a capillary structure
2 coupled to the wicking material, said capillary structure bring said fluid to the sensory
3 material positioned on a plurality of electrodes located in the capillary structure.

1 27. The method of claim 21 further comprising a capillary structure
2 coupled to the wicking material, said capillary structure bring said fluid to the sensory
3 material positioned on a plurality of electrodes and are in fluid communication with the
4 capillary structure.

1 28. The method of claim 21 further comprising a plurality of electrodes
2 each having a sensory material.

1 29. The method of claim 21 a plurality of sets of electrodes are
2 associated with each penetrating member.

1 30. The method of claim 21 wherein the wicking material has a
2 lollipop configuration.

1 31. The method of claim 21 wherein the wicking material is oriented
2 perpendicular to a path of the penetrating member.

1 32. The method of claim 21 wherein the wicking material is oriented
2 to intersect a path of the penetrating member.

1 33. The method of claim 21 wherein topside connecting sections of
2 the wicking member comprises a PET film hydrophobic on an outer most layer and
3 hydrophilic on an inner layer abutting against the hydrophobic double-sided adhesive
4 layer.

1 34. The method of claim 21 wherein bottom side g sections of the
2 wicking member comprises a PET film hydrophilic on the inner layer abutting against the
3 hydrophobic adhesive and hydrophobic on the outside, wherein an inner fluidic channel
4 region is a sandwich structure of top PET film / fluidic mesh structures / and bottom PET
5 film, wherein the PET surfaces abutting the mesh structures are hydrophilic.

1 35. The method of claim 21 wherein a plurality of wicking members
2 are positioned in a ring configuration around the cartridge.

1 36. The method of claim 21 wherein a plurality of wicking members
2 are positioned in a ring configuration around the cartridge, with at least one wicking
3 member for each penetrating member in the cartridge.

1

1/19

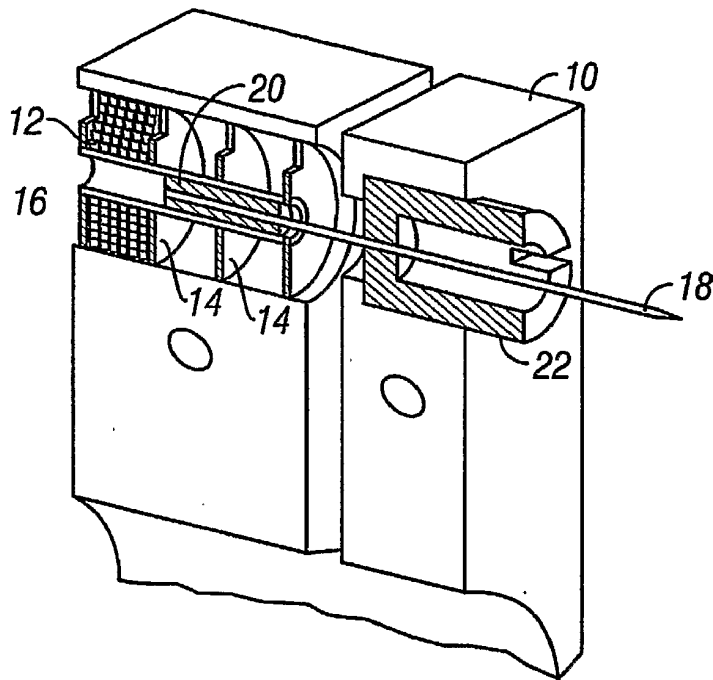

FIG. 1

2/19

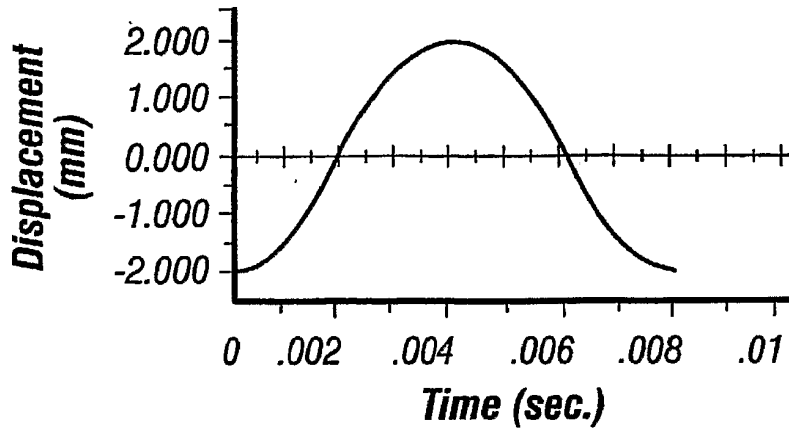

FIG. 2A

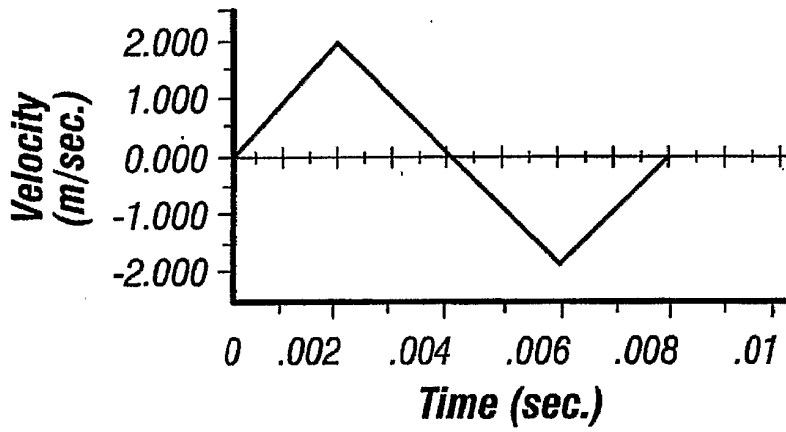

FIG. 2B

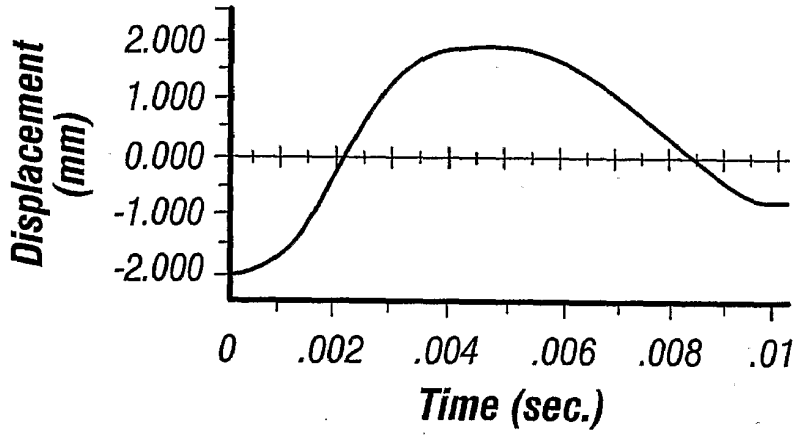

FIG. 2C

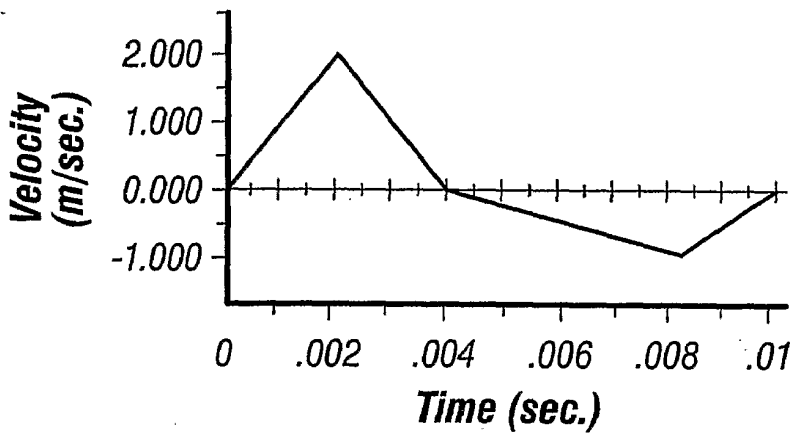

FIG. 2D

4/19

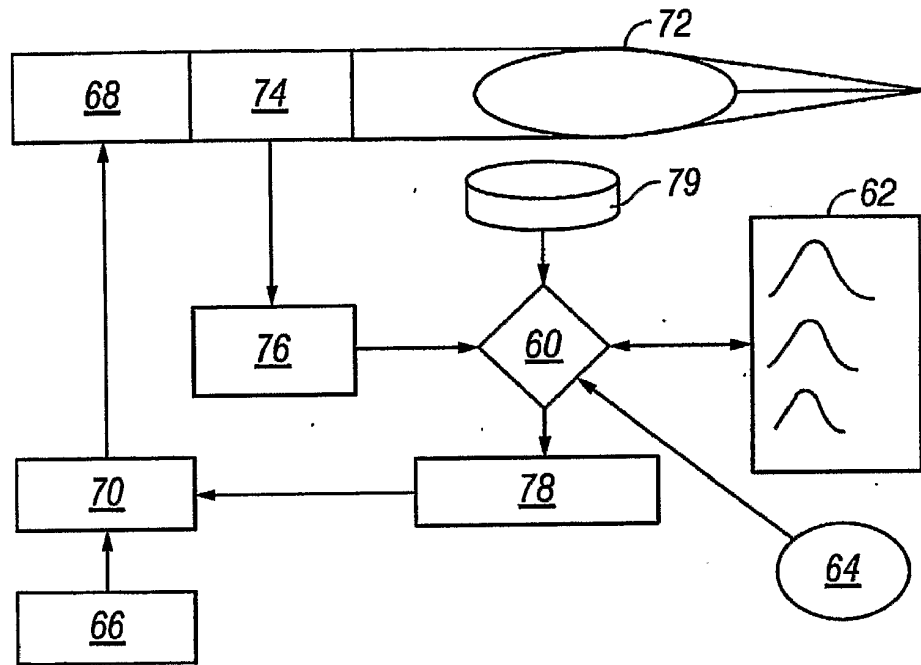

FIG. 3

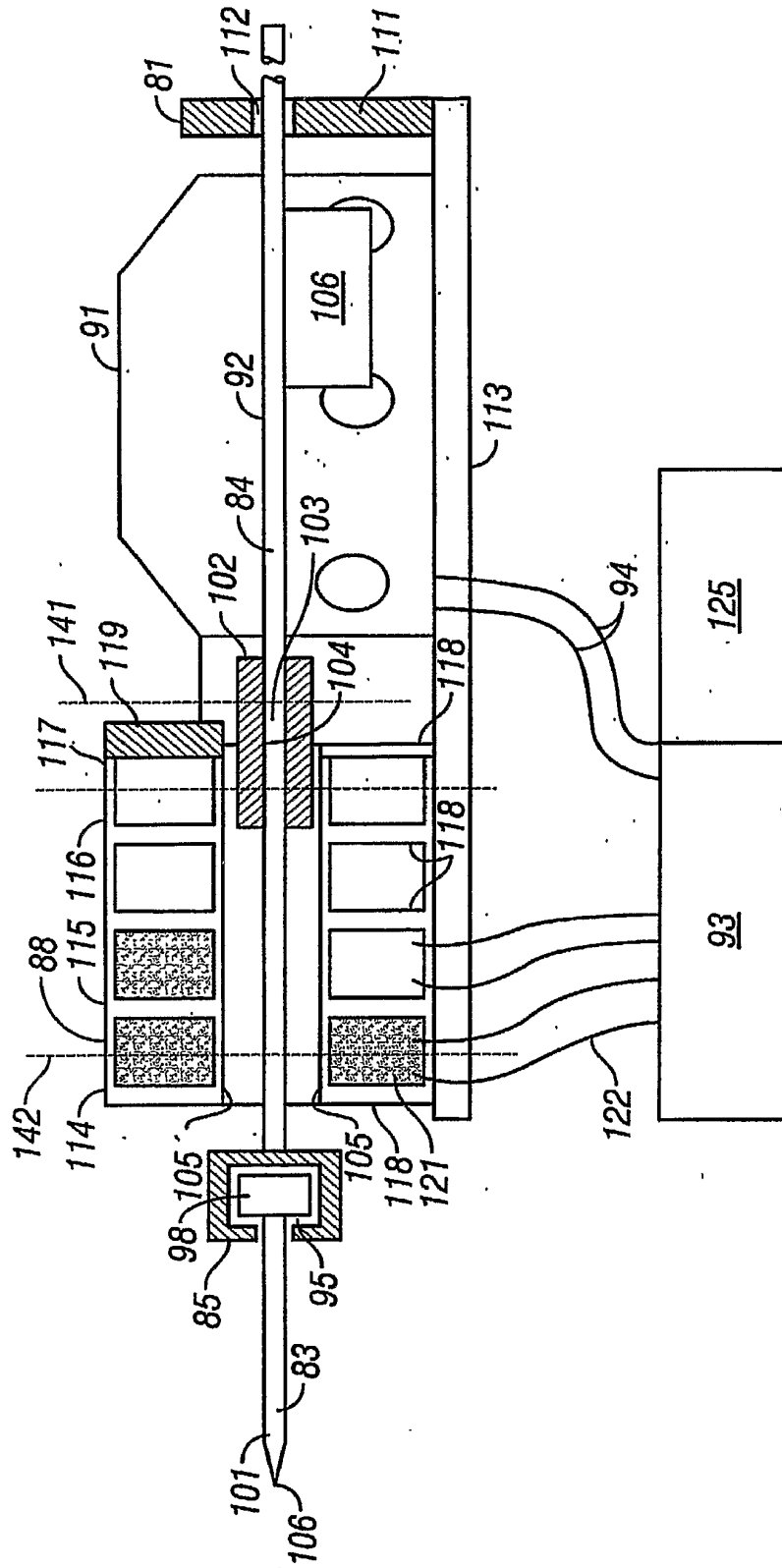

FIG. 5

7/19

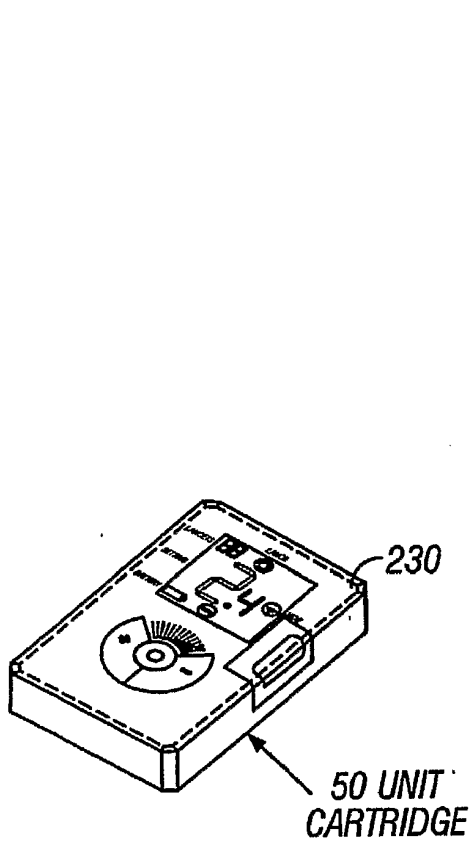

FIG. 6A

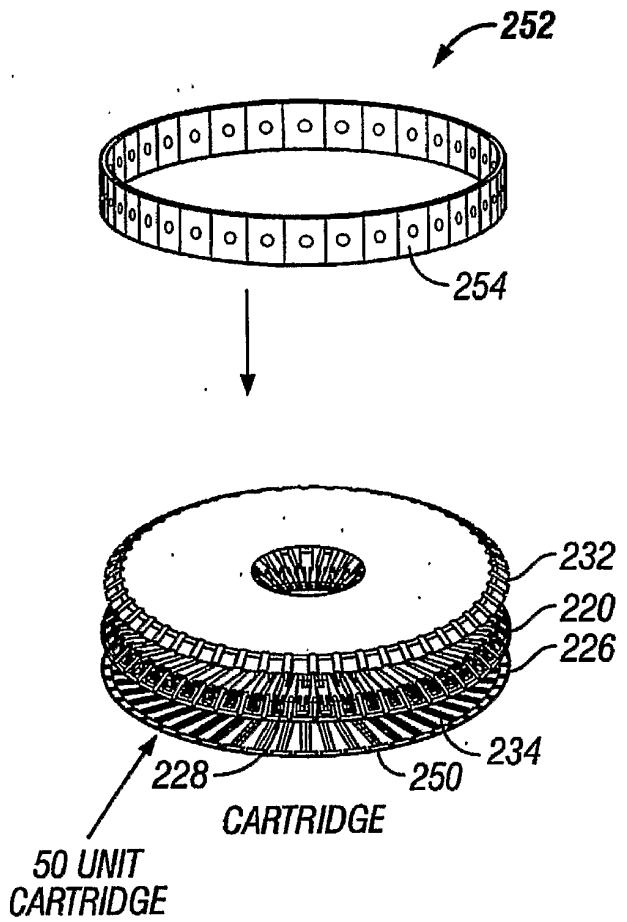

FIG. 6B

8/19

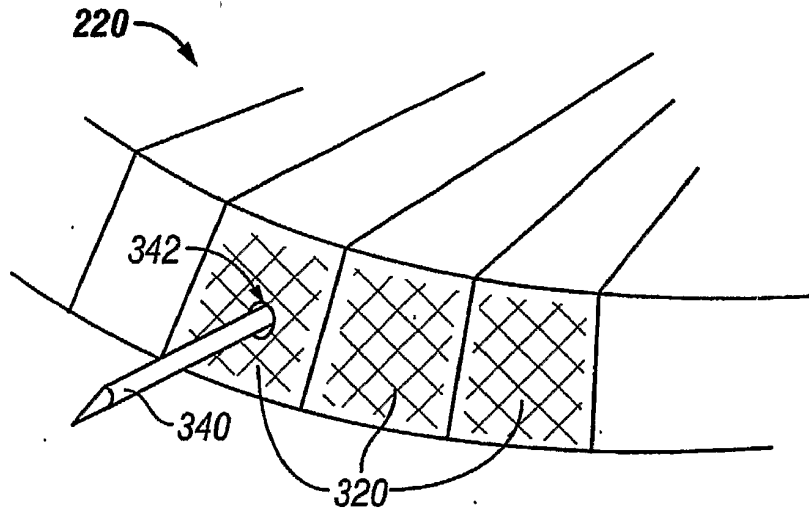

FIG. 7

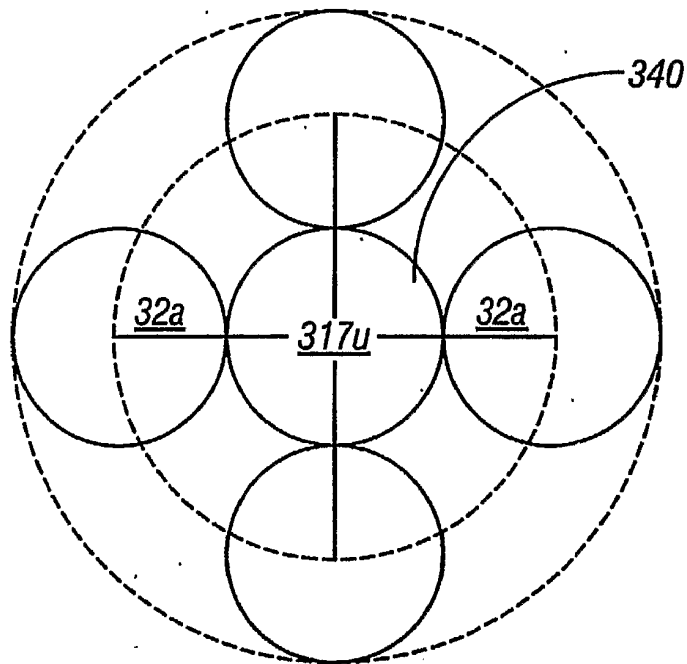

FIG. 8

9/19

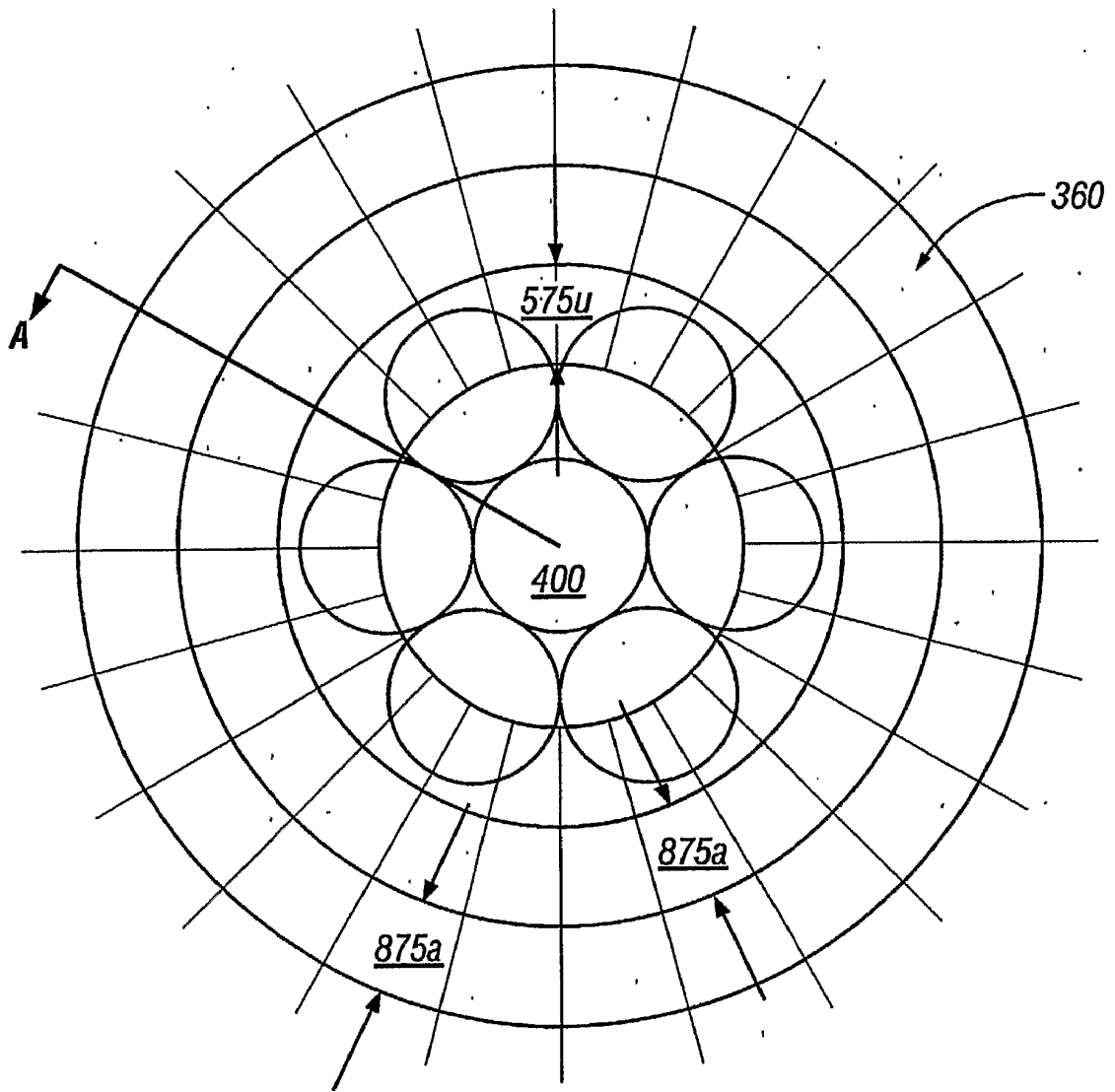

FIG. 9

10/19

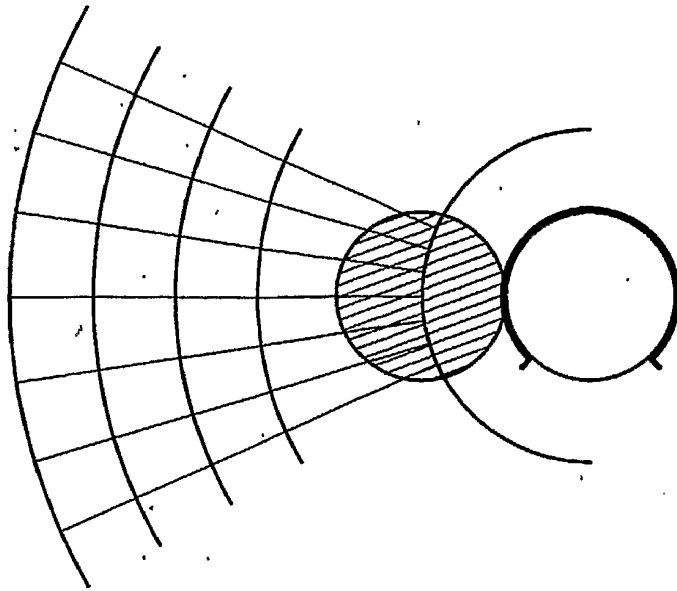

FIG. 10A

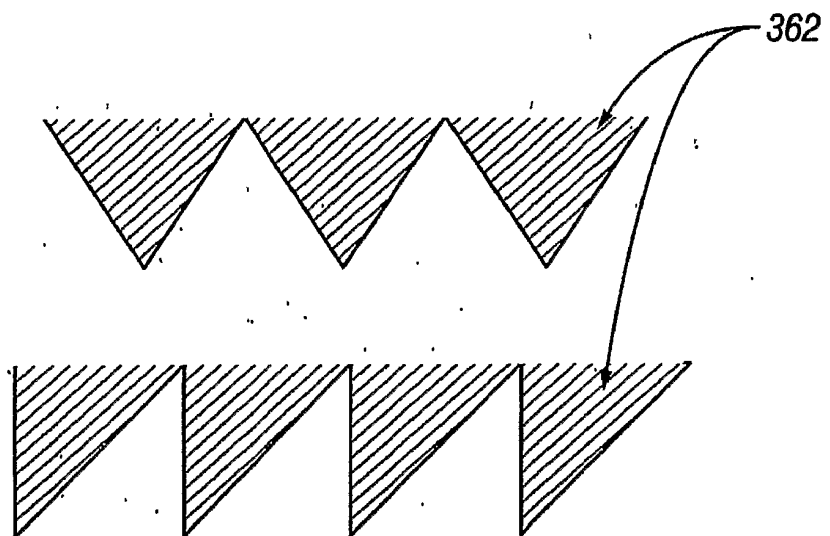

FIG. 10B

11/19

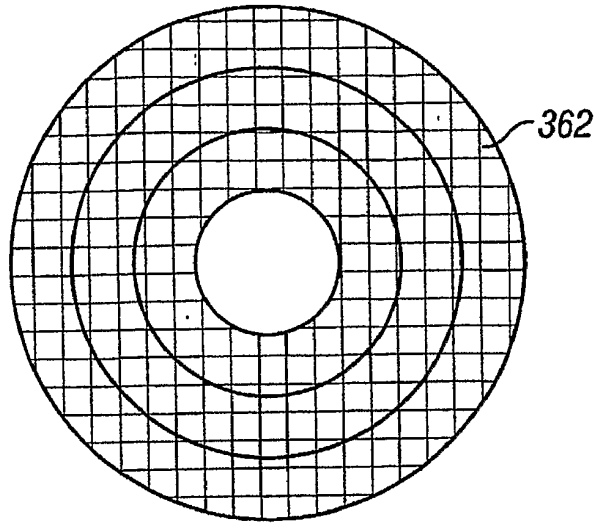

FIG. 10C

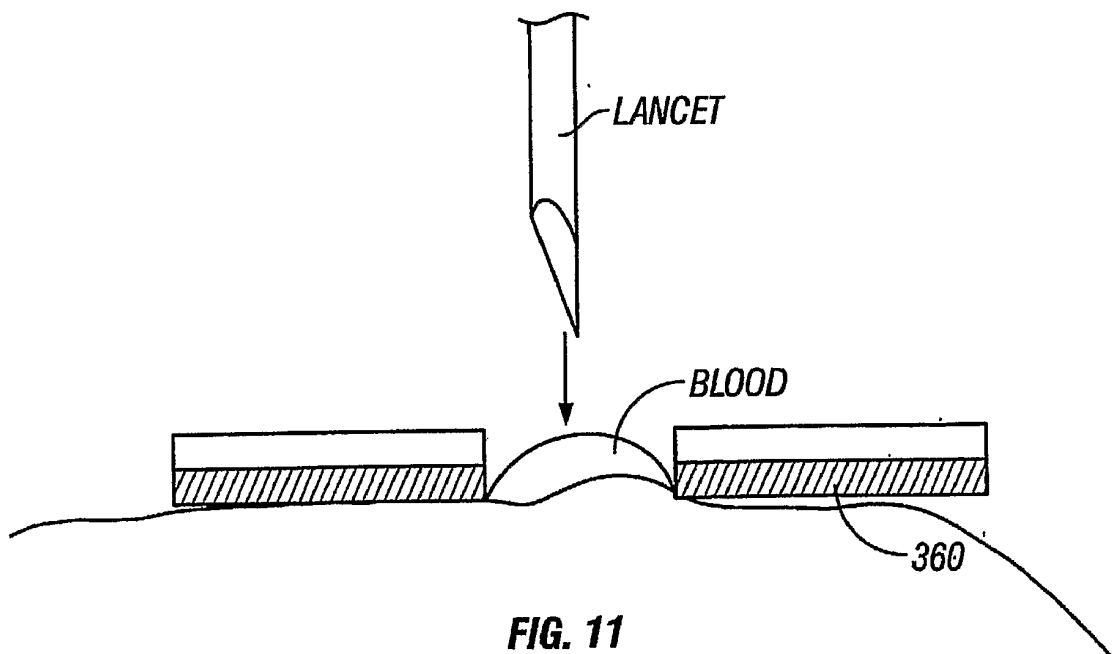

FIG. 11

12/19

380

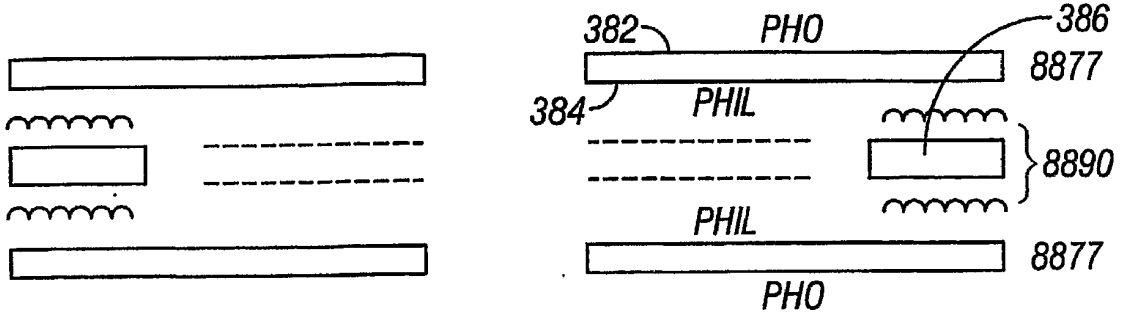

FIG. 12A

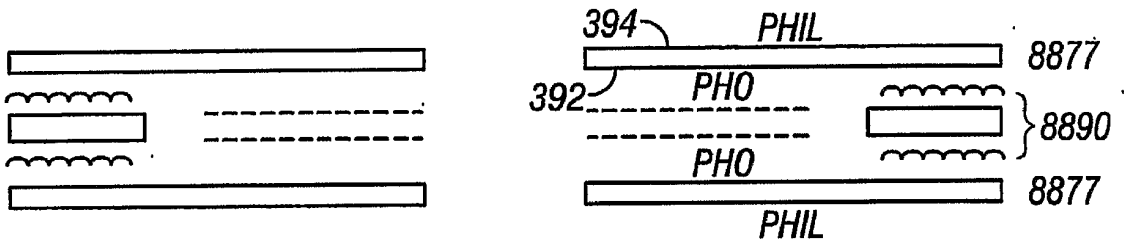

FIG. 12B

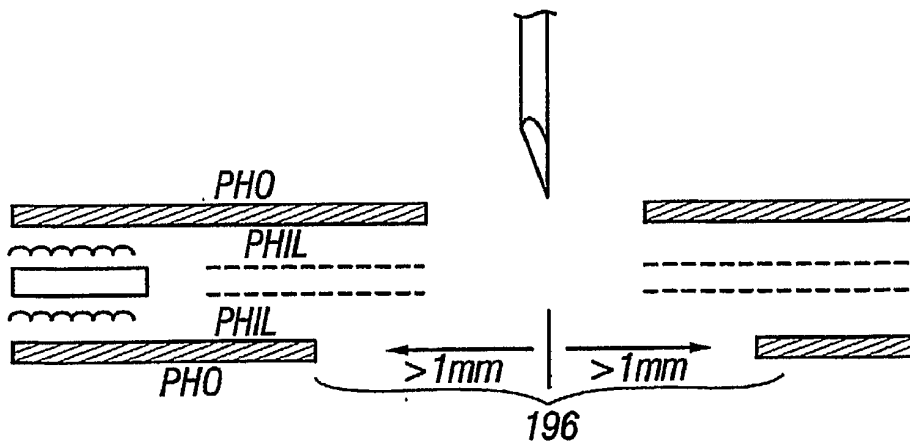

FIG. 12C

13/19

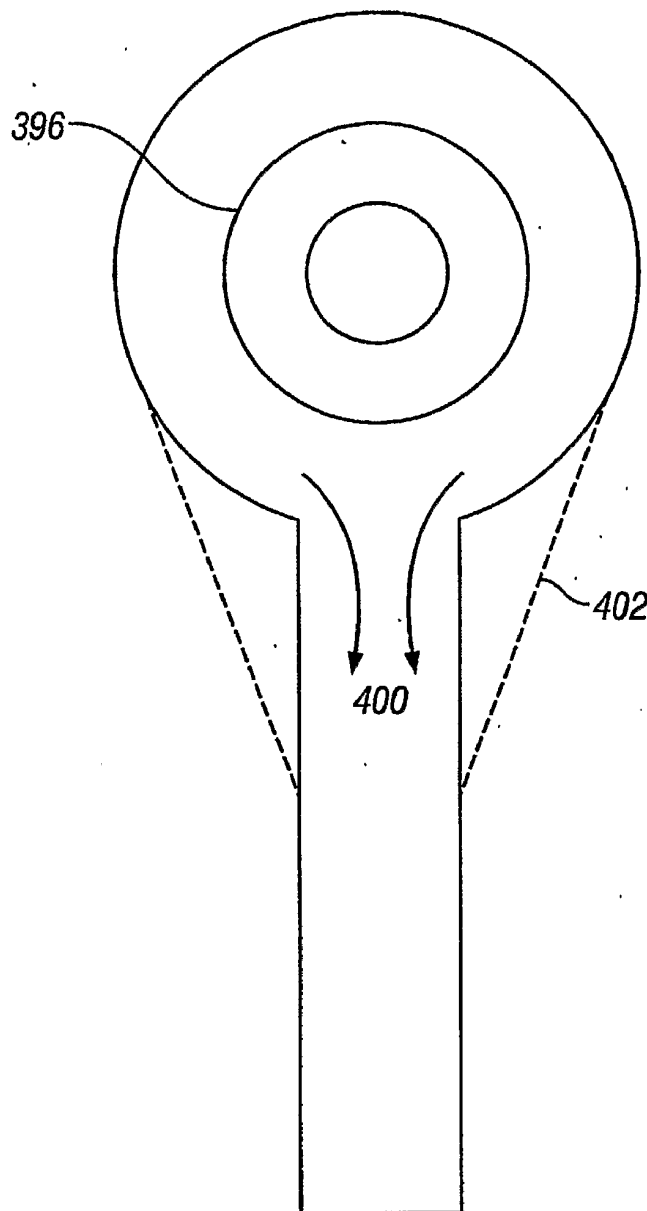

FIG. 12D

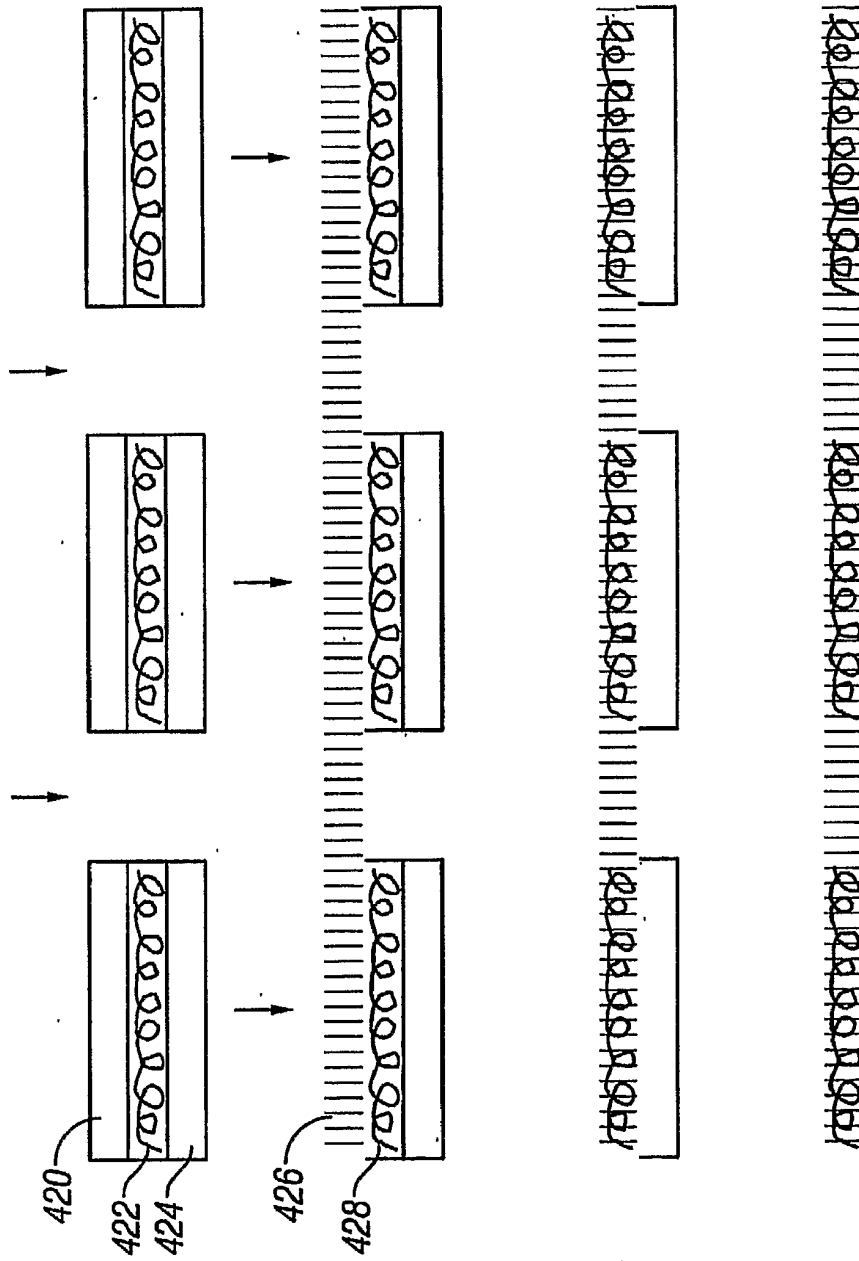

FIG. 13

15/19

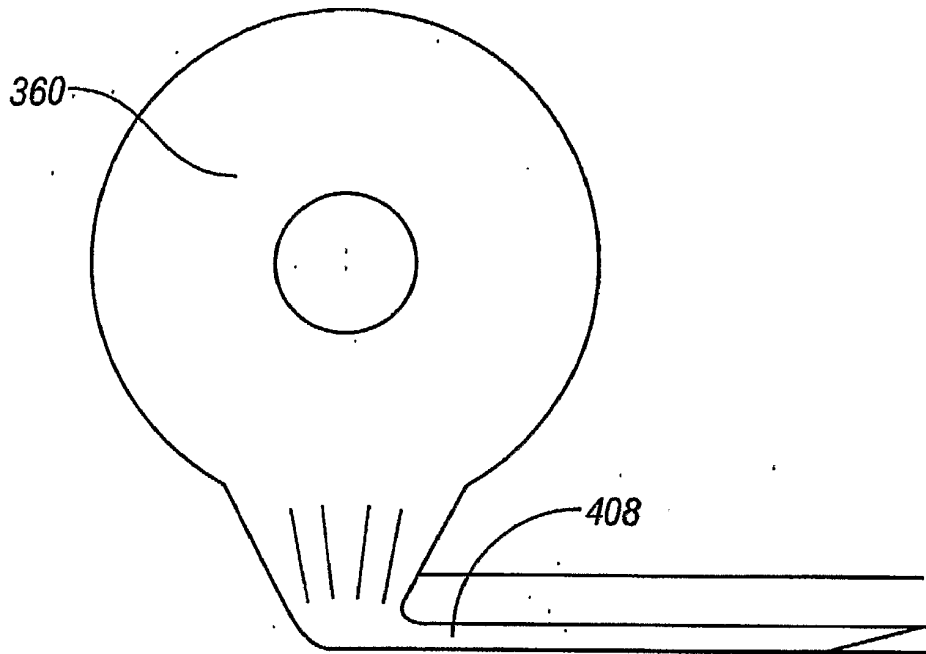

FIG. 14

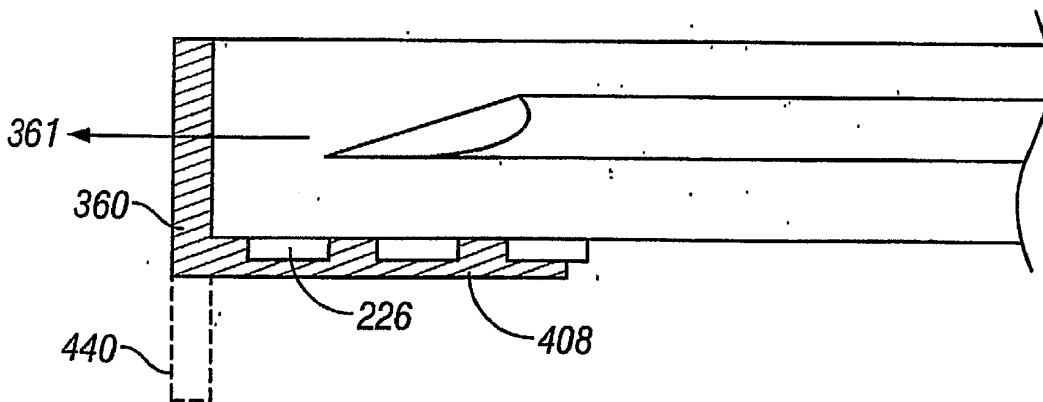

FIG. 15

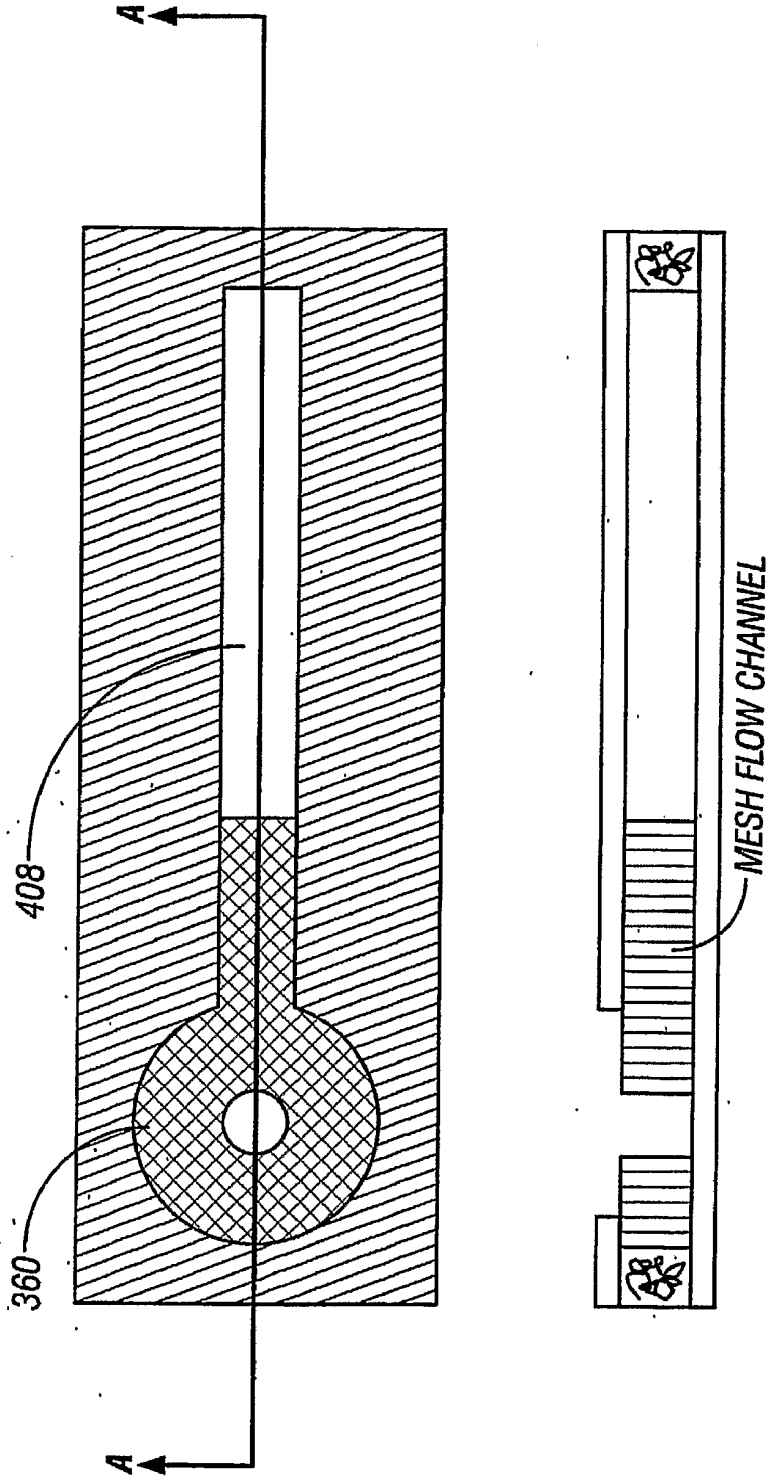

FIG. 16

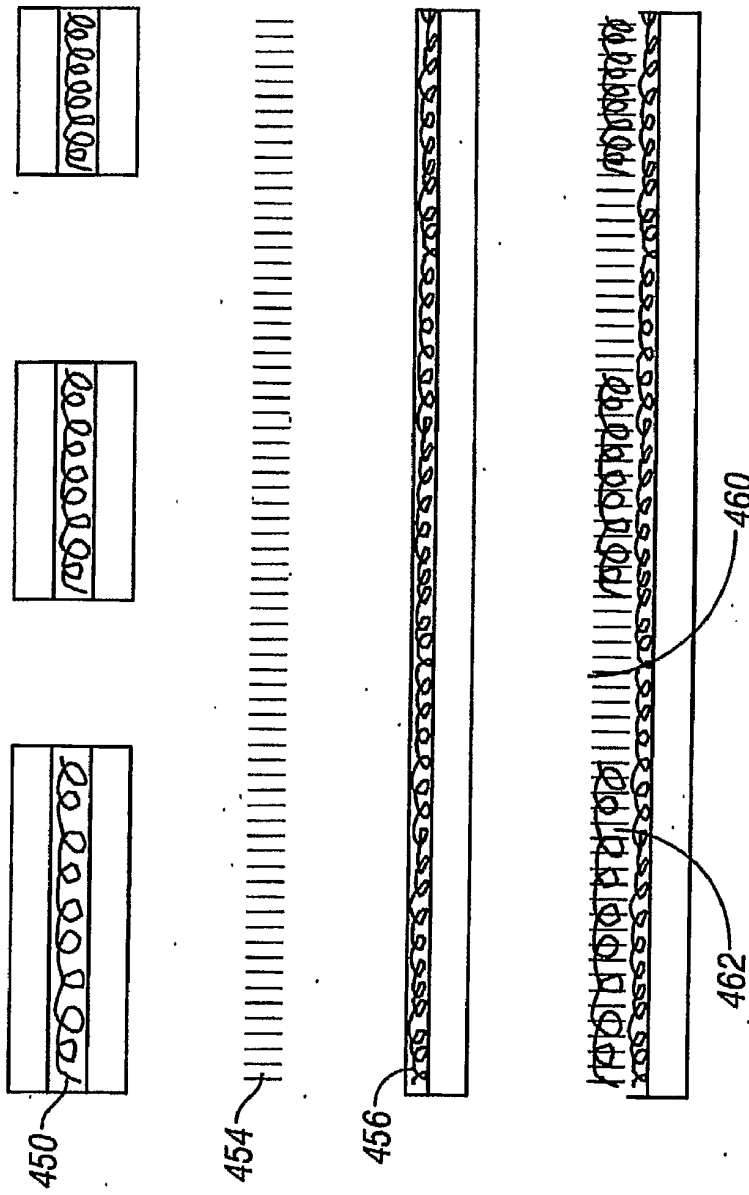

FIG. 17

18/19

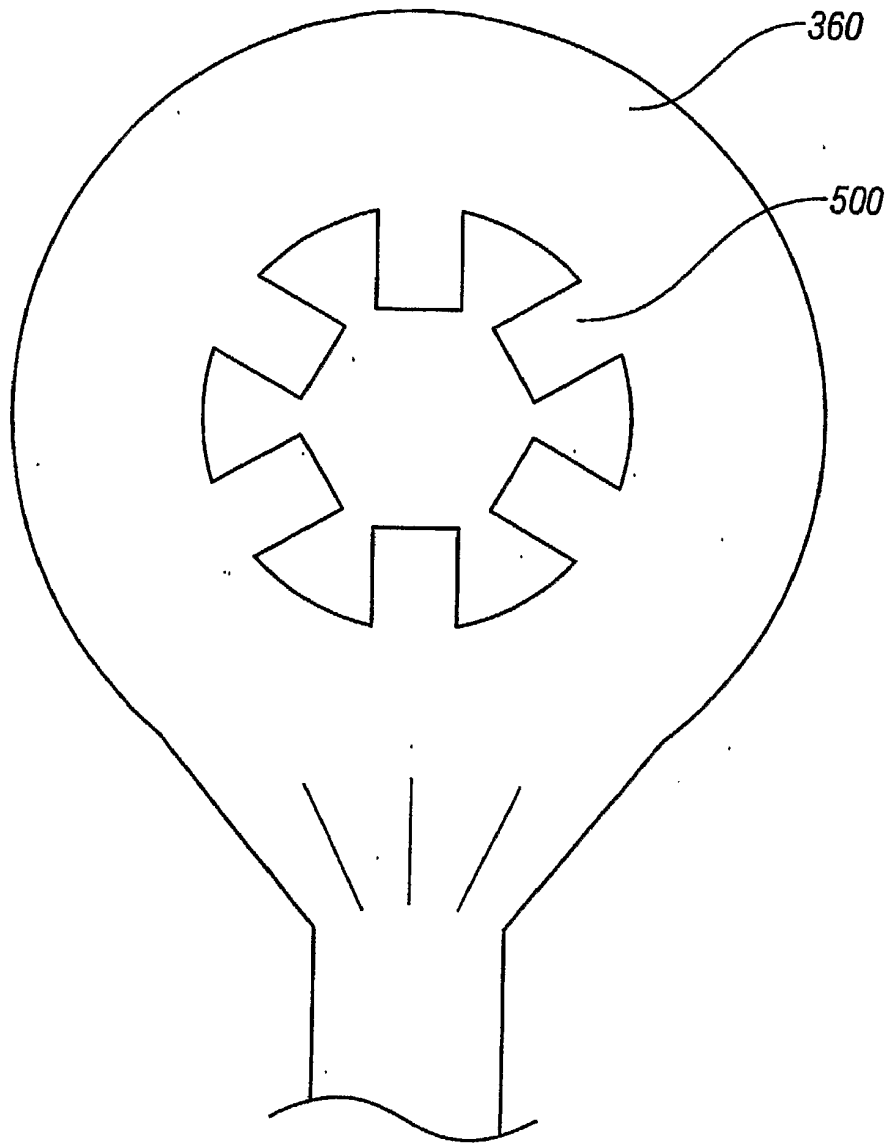

FIG. 18

19/19

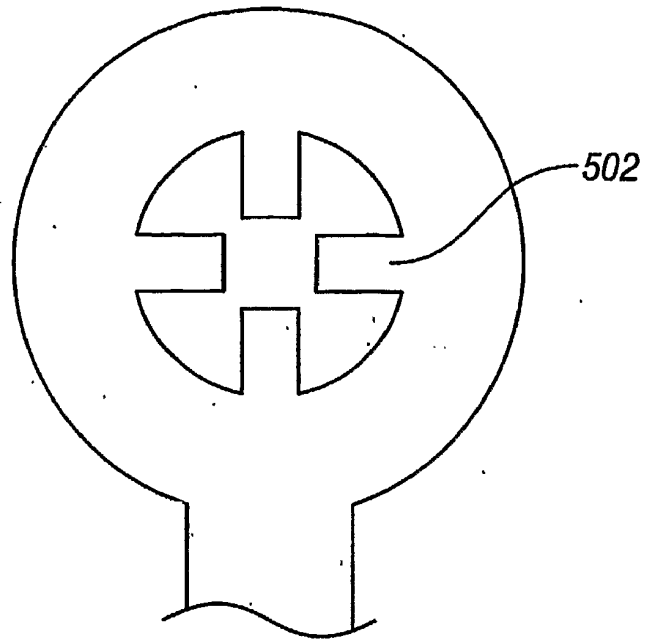

FIG. 19

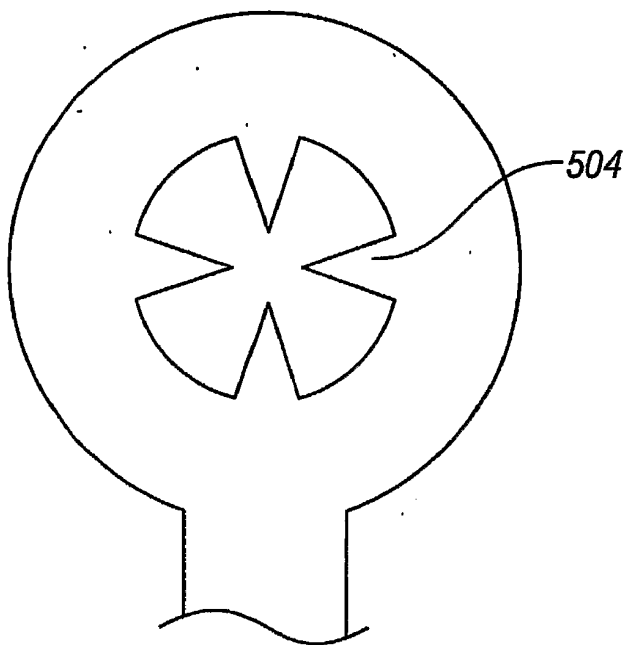

FIG. 20

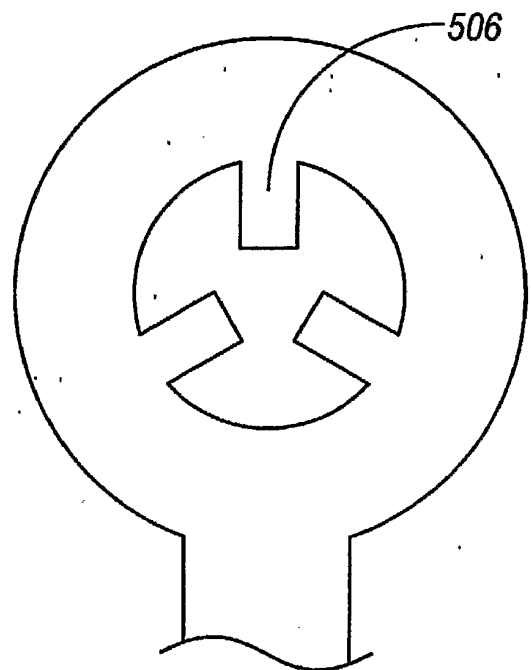

FIG. 21

专利名称(译)	用于改善流体流动和样本捕获的方法和设备		
公开(公告)号	EP1706026A4	公开(公告)日	2009-12-23
申请号	EP2004816035	申请日	2004-12-31
[标]申请(专利权)人(译)	佩利坎技术公司		
申请(专利权)人(译)	PELIKAN科技股份有限公司.		
当前申请(专利权)人(译)	PELIKAN科技股份有限公司.		
[标]发明人	LUM PAUL MAUZE GANAPATI POPLONSKI TOMASZ SHATSKY REBECCA		
发明人	LUM, PAUL MAUZE, GANAPATI POPLONSKI, TOMASZ SHATSKY, REBECCA		
IPC分类号	A61B5/00 A61B5/15 A61B5/151 A61B5/157		
CPC分类号	A61B5/15101 A61B5/1411 A61B5/150022 A61B5/150152 A61B5/150167 A61B5/150175 A61B5/150358 A61B5/150419 A61B5/150427 A61B5/15045 A61B5/150503 A61B5/150572 A61B5/15113 A61B5/15123 A61B5/15151 A61B5/15161 A61B5/15176 A61B5/157 A61B2017/3437		
代理机构(译)	HARRIS , RICHARD IAN		
优先权	60/533981 2003-12-31 US		
其他公开文献	EP1706026A2 EP1706026B1		
外部链接	Espacenet		

摘要(译)

提供了一种用于在刺破患者时捕获体液的系统和方法。在一个实施例中，将流体样本捕获孔网（320）环放置在手指穿透构件（340）的路径中。开口网眼环具有中心间隙区域，该中心间隙区域允许穿透构件无障碍地刺穿皮肤。孔眼网环可以包含一系列流体采样网孔，以允许释放的体液“芯吸”到流体采样网孔中以传输到相应的传感器。本发明还可以涉及一种改善通过膜网孔结构的流体流动以将体液从采样点传输到测量点的方法。

