



(12) **EUROPEAN PATENT SPECIFICATION**

(45) Date of publication and mention  
of the grant of the patent:  
**31.08.2005 Bulletin 2005/35**

(21) Application number: **00939701.9**

(22) Date of filing: **09.06.2000**

(51) Int Cl.<sup>7</sup>: **A61N 1/36**

(86) International application number:  
**PCT/US2000/015798**

(87) International publication number:  
**WO 2000/076580 (21.12.2000 Gazette 2000/51)**

(54) **FEEDBACK MECHANISM FOR DEEP BRAIN STIMULATION**

RÜCKKOPPLUNGSMECHANISMUS ZUR STIMULATION TIEFLIEGENDER GEHIRNBEREICHE

MECANISME DE RETROACTION POUR STIMULATION CEREBRALE PROFONDE

(84) Designated Contracting States:  
**AT BE CH CY DE DK ES FI FR GB GR IE IT LI LU  
MC NL PT SE**

(30) Priority: **11.06.1999 US 330935**

(43) Date of publication of application:  
**03.04.2002 Bulletin 2002/14**

(60) Divisional application:  
**05075990.1 / 1 559 369**

(73) Proprietor: **CORNELL RESEARCH FOUNDATION,  
INC.  
Ithaca, NY 14850 (US)**

(72) Inventors:  
• **SCHIFF, Nicholas D.**  
**New York, NY 10021 (US)**  
• **PURPURA, Keith**  
**New York, NY 10021 (US)**  
• **KALIK, Steven**  
**New York, NY 10021 (US)**

(74) Representative: **Miles, John Stephen**  
**Eric Potter Clarkson,**  
**Park View House,**  
**58 The Ropewalk**  
**Nottingham NG1 5DD (GB)**

(56) References cited:  
**EP-A- 0 799 597** **WO-A-97/45160**

**Description**

[0001] The present invention was made with funding under National Institutes of Health Grant Nos. NS36699 and KO8 NS02014-02. The U.S. Government may have certain rights.

**FIELD OF THE INVENTION**

[0002] The present invention relates generally to apparatus for deep brain electrical stimulation methods and, more particularly, apparatus for treating conscious patients having impaired cognitive function.

**BACKGROUND OF THE INVENTION**

[0003] Brain injuries which lead to impaired cognitive function remain the least explored area for active neurological intervention. Several clinical observations suggest that mechanisms of plasticity are available to the brain that might be harnessed for therapeutic advantage for treating cognitive disorders. A significant percentage, roughly 20%, of patients who suffer severe brain damage remain conscious with preserved capacity for memory, attention, intention, and awareness. In many cases, these patients fluctuate dramatically (e.g., the well-known case of Gary Dockery, the brain-injured police officer who "woke up" and interacted with his family for nearly twenty-four hours after seven years of minimal responsiveness - Chicago Tribune 1/29/97 "After Miracle Coma Patient Has Way to Go").

[0004] There has been a striking lack of therapeutic options for these patients, despite evidence of their capacity to further optimize their brain function; this capacity is evident in the spontaneous fluctuations of functional level in many patients and the induced functional changes in some patients following sensory stimulation or patient initiated behaviors. The significance of developing a therapeutic intervention for patients having impaired cognitive function, especially those who remain conscious with preserved capacity for memory, attention, intention, and awareness lies in both the devastating reduction in quality of life they suffer and the economic burden these patients place on the health care system. These costs include full-time care in nursing and chronic rehabilitation facilities. Moreover, head trauma accounts for the largest percentage of these patients and most patients having impaired function caused by head trauma are under 40 years of age. Such patients represent a disproportionate economic cost in terms of both the loss of their expected productivity and the attendant costs of very long-term full-time care based on their young age.

[0005] Vestibular stimulation has been shown to reverse cognitive impairments. Schiff, et al., "Does Vestibular Stimulation Activate Thalamocortical Mechanisms That Reintegrate Impaired Cortical Regions?," Proc. R. Soc. Land. B. 266:421-23 (1999). However, improved procedures for controlling such stimulation is needed.

[0006] The present invention is directed to overcoming this deficiency.

[0007] WO 97/45160 (D1) describes methods and apparatus for treatment of memory disorders by stimulation of a patient's vagus nerve.

**SUMMARY OF THE INVENTION**

[0008] The present invention relates to a cognitive function improving apparatus comprising:

means for applying electrical stimulation to at least a portion of a patient's subcortical structures involved in the generation and the control of generalised efference copy signals under conditions effective to improve the patient's cognitive function,

means for detecting internally generated saccadic eye movement of the patient; and

means for controlling the applied electrical stimulation in response to detected internally generated saccadic eye movement of the patient.

[0009] Preferred embodiments of the invention are as described in Claims 2-31.

[0010] The present invention relates to apparatus for treating a conscious patient to improve cognitive function. The conscious patient may or may not have impaired cognitive function. Electrical stimulation is applied to at least a portion of the patient's subcortical structures involved in the generation and control of generalized efference copy signals under conditions effective to improve the patient's cognitive function. Internally generated saccadic eye movement of the patient is then detected and, in response to such internally generated movement, application of electrical stimulation is controlled.

[0011] The present invention also relates to a apparatus for improving coordination of function across cortical regions in a patient. The apparatus is suitable for applying electrical stimulation to two or more subdivisions of the subcortical structures integrated in the generation and control of generalized efference copy signals. The two or more subdivisions modulate separate cortical regions. Electrical stimulation is again followed by detection of internally generated saccadic

eye movement of the patient and, in response, control of the electric stimulation.

[0012] Using the apparatus of the present invention, patients suffering from impaired cognitive function can have at least a portion of the function restored, thus improving their quality of life and reducing societal costs. As apparatus for providing deep brain stimulation the present invention has several specific advantages over empirical adjustment of frequency and intensity of the electrical stimulation alone by identifying a natural pulse sequence for patterning of the stimulation. The added utility of these feedback pulses is that they offer increased flexibility in terms of both identifying additional targets of stimulation by using a synchronizing pulse that these areas are prepared to receive and improving the probability that complex brain injuries may be successfully treated because of a greater selectivity of using a natural pulse sequence. An important additional therapeutic advantage is that feedback as used here allows for patient biofeedback and self-regulation to play a role in the use of the application of the simulation technology for therapeutic purposes.

### BRIEF DESCRIPTION OF THE DRAWINGS

[0013]

Figure 1 is a schematic diagram of the anatomical connections of the intralaminar nuclei with distributed circuits underlying arousal, attention, and gaze control.

Figures 2A-2E are photographs of brain sections illustrating intralaminar nuclei subdivisions suitable for stimulation in accordance with the practice of the present invention.

Figure 3 shows a protocol for implementation of the process of the present invention.

Figure 4 is a schematic diagram of equipment useful in controlling stimulation of intralaminar nuclei as a function of saccadic eye movement.

Figure 5 shows a schematic diagram of pulse sequence time dependence on saccade parameters.

Figure 6A is a schematic of feedback stimulation from saccadic eye movement.

Figure 6B shows the identification of saccadic eye-movements and feedback pulse control.

### DETAILED DESCRIPTION OF THE INVENTION

[0014] The present invention relates to apparatus for treating a conscious patient to improve cognitive function. The conscious patient may or may not have impaired cognitive function. Electrical stimulation is applied to at least a portion of the patient's subcortical structures involved in the generation and control of generalized efference copy signals under conditions effective to improve the patient's cognitive function. Internally generated saccadic eye movement of the patient is then detected and, in response to such internally generated movement, application of electrical stimulation is controlled.

[0015] As used herein, cognitive function means the information processing capacities of the brain, including all semantic information processing, including interpretation of external and internal sensory signals and integration of those signals to support behavior. Perceptual awareness, as used herein, is a subset of cognitive function and is meant to include the mechanisms of selecting, organizing, and classifying internally or externally generated brain signals. A variety of methods can be used to assess a patient's cognitive function and to detect deficits in perceptual awareness. These include clinical neurological and neuropsychological evaluation and administration of detailed neuropsychological test batteries.

[0016] The patient with impaired cognitive function may have that condition alone, or, alternatively, the patient may suffer from a variety of other ailments in addition to impaired cognitive function. Such other ailments may include chronic pain or generalized seizures, each of which conditions may be present without the other. Alternatively, patients with impaired cognitive function may additionally suffer from both chronic pain and generalized seizures. Patients with impaired cognitive function alone, patients with impaired cognitive function accompanied by either chronic pain or generalized seizures, and patients with impaired cognitive function accompanied by both chronic pain and generalized seizures can all benefit from the practice of the present invention. As used herein, chronic pain means a syndrome of protracted pain, typically resulting from a persistent activation of central pain mechanisms (i.e., in the brain (commonly referred to as "neuropathic pain") as opposed to pain which results primarily from activation of pain mechanisms in the peripheral nervous system. As used herein, generalized seizures is meant to include epileptic seizures, such as those experienced by severe medication resistant refractory epileptics (i.e., patients who have been treated with multiple anti-epileptic medications at near toxic doses and failed this therapy as evidenced by their continuing to have multiple seizures daily despite such medication).

[0017] The apparatus of the present invention is suitable for use on patients whose cognitive dysfunction (e.g., impaired perceptual awareness) is, for example, produced, at least in part, by brain injuries, including those produced, at least in part, by stroke, head trauma (e.g., blunt head trauma or missile penetration), toxicological agents (e.g.,

carbon monoxide, arsenic, or thallium), anoxia (e.g., reduced oxygen levels in the blood), ischemia (e.g., reduced blood flow), nutritional deficiencies, developmental diseases, infectious diseases, neoplastic diseases, degenerative diseases, complications thereof, or other structural lesions.

**[0018]** These brain injuries frequently manifest themselves in combined deficits of attention, intention, working memory, and/or awareness. As used herein, attention refers to the cognitive function that provides the capacities for selection of internal or external stimuli and thoughts, supports the preparation of intended behaviors (e.g., speeds perceptual judgments and reaction times), and supports the maintenance of sustained cognition or motor behaviors (e.g., the focusing of attention). Intention, as used herein, refers to the mechanism of response failures (i.e., lack of behavioral interaction) which is not due to a perceptual loss (i.e., intention is the cognitive drive linking sensory-motor integration to behavior). Intention deficits include failure to move a body part despite intact motor pathways, awareness, and sensory processing as demonstrated by neurophysiological and neuropsychological evaluation. Another example of a patient's intention deficit is a failure to initiate action of any kind despite evidence of awareness or action produced by stimulation. Loss of intention is a disorder of cognitive function, as defined herein, and is a major division of the neuropsychological disorder of neglect, which may be present in many patients with cognitive loss following brain injury. Working memory, as used herein, refers to the fast memory process required for on-line storage and retrieval of information, including processes of holding incoming information in short-term memory before it can be converted into long-term memory and processes which support the retrieval of established long-term (episodic) memories. Deficits in awareness relate to impaired perceptual awareness, as described above. Clinical signs of these brain injuries also include profound hemi-spatial neglect, disorders of motor intention, disorders of impaired awareness of behavioral control, or apathy and cognitive slowing.

**[0019]** A patient's attention, intention, working memory, and/or awareness function can be evaluated using standard tests. Most of these test batteries encompass the different types of basic cognitive functions and are used to initially screen a patient for a pattern of deficits. More specific tests can be employed and individualized to a patient's neuropsychological profile. In practice, the choice of particular neuropsychological test batteries depends on the experience of the tester and the normative data available for the test. This changes as new studies are done and as new testing materials are tried out and compared. For example, suitable comprehensive tests include the Mental Status Exam ("MSE") (set forth, for example, in Strub et al., The Mental Status Exam in Neurology, 3rd ed., Philadelphia: Davis (1993)), as well as broad neuropsychological test batteries, like the Halstead-Reitan Neuropsychological Test Battery (which encompasses memory, attention, intention, and perception/awareness). In order to delineate more narrowly specific deficits of working memory, attention, perception, etc., more individualized tests can be chosen. For example, a 'Shibley-Hartford scale' test may be employed to assess cognitive slowing (intelligence); a 'Bender-Gestalt' test can be used to assess spatial relations and constructions; Aphasia screening tests, such as the Boston Diagnostic Aphasia Examination or the Western Aphasia Battery, can detect language dysfunction; and Trials A/B or Memory Assessment Scales ("MAS") test can be used to assess working memory. Further details with regard to these and other tests for assessing a patient's attention, intention, working memory, and/or awareness function can be found in, for example, Berg, "Screening Tests in Clinical Neuropsychology," Chapter 10, pp. 331-363, in Horton et al., eds., The Neuropsychology Handbook. Vol. 1. Foundations and Assessment, 2nd ed., New York: Springer Publishing Company (1997).

**[0020]** Clinical guidelines for patient selection are based on the patient's functional disturbance. For example, the patient's cognitive impairment may be slowing (or, in a severe case, dementia), as manifested in the patient's decreased attention, impaired intention, and decreased working memory. Alternatively, the patient may exhibit primary failure to initiate action despite interaction when stimulated. Patient selection in the clinical setting would also depend, in part, on prognostic signs, such as the presence of spontaneous fluctuations in functional level, modulation of functional level by external stimulation, or reliably produced modulation by internally generated stimulation.

**[0021]** As indicated above, the present invention relates to apparatus for treating a conscious patient having impaired cognitive function. Conscious, as used herein, has the conventional meaning, as set forth in Plum, et al., The Diagnosis of Stupor and Coma, CNS Series, Philadelphia: Davis (1982).

**[0022]** Conscious patients include those who have a capacity for reliable, reproducible, interactive behavior evidencing awareness of self or the environment. Conscious patients include patients who recover consciousness with less severe brain injury but who, because of their impaired cognitive function, do not reach independent living and remain in nursing facilities. Conscious patients do not include those who exhibit wakefulness but lack interaction (e.g., those deemed to be in a persistent vegetative state). A significant percentage, roughly 20% of patients who suffer severe brain damage remain conscious with preserved capacity for memory, attention, intention, and awareness. This is in contrast to patients who suffer from states of global unconsciousness, as indicated by conditions such as coma, persistent vegetative states, apallic state, coma vigil, and severe dementia.

**[0023]** Since adult patients in their twenties to forties have the most to gain from treatment and represent the greatest cost to society if left untreated, they would be preferred candidates for the intervention of the present invention. However, patients younger or older than those in the above age range would also benefit from the practice of the present invention. Although, in the early stages of clinical application, the present invention is likely to be targeted at more seriously

compromised patients, it is believed that, ultimately, the apparatus will have wider application to patients with mild to moderate cognitive impairment following brain injury as well. Patients suffering from post encephalitic parkinsonism or other disease processes which include oculogyric crises as a symptom are envisioned as being one class of patients who can be treated using the method of the present invention.

5 [0024] Once the conscious patient having impaired cognitive function is selected, electrical stimulation is applied to at least a portion of the patient's intralaminar nuclei under conditions effective to relieve the patient's impaired cognitive function.

10 [0025] Generally, stimulation of the patient's intralaminar nuclei involves contacting the intralaminar nuclei with an electrode capable of delivering an electrical signal to the patient's intralaminar nuclei. A variety of electrodes can be employed for delivering the stimulation. For example, suitable electrodes include the deep brain stimulation electrodes used in Katayama, "Characterization and Modification of Brain Activity with Deep Brain Stimulation in Patients in a Persistent Vegetative State: Pain-Related Late Positive Component of Cerebral Evoked Potential," Pace, 14:116-121 (1991), and the Medtronic DBS 3280 (available from Medtronic, Minneapolis, Minnesota), which has a flexible TE-FLON-SILASTIC™ coated, platinum indium electrodes with 4 contacts, 4 mm tips, 2mm, mean tip separation, and an impedance of 5-7 kΩ within the brain, described in Velasco et al., "Electrocortical and Behavioral Responses Produced By Acute Electrical Stimulation of the Human Centromedian Thalamic Nucleus," Electroencephalography and Clinical Neurophysiology, 102:461-471 (1997) ("Velasco"). Preferably the electrode is an implantable multipolar electrode with either an implantable pulse generator that can be a radiofrequency controlled device operated by an external transmitter. Preferably, the multipolar electrode contacts should allow for adjustment of frequency (or "rate"), amplitude, and pulse width within at least the following respective ranges: about 2-200 Hz, about 0.1-10 Volts, and about 50-500 microseconds. More preferably, the multipolar electrode contacts allow for adjustment in a broader range than those recited above, particularly toward higher intensities. Such preferred electrodes include a Medtronic 3387 electrode (available from Medtronic, Minneapolis, Minnesota) and are described, for example, in Benabid et al., "Chronic Electrical Stimulation of the Ventralis Intermedius Nucleus of the Thalamus As a Treatment of Movement Disorders," J Neurosurgery, 84:203-214 (1996). In some situations, it may be desirable to use an electrode capable of delivering pharmacological agents to the patient's subcortical structures. Such electrodes include electrodes with microcannulae and are described in, for example, Hikosaka et al., "Modification of Saccadic Eye Movements by GABA-related Substances. I. Effect of Muscimol and Bicuculline in Monkey Superior Colliculus." J. Neurophysiology, 53:266-291 (1985). Examples of suitable pharmaceutical agents which can be used in conjunction with the electrical stimulation methods of the present invention include known excitatory and inhibitory transmitters that influence intralaminar nuclei function. Excitatory transmitters would preferably include acetylcholine ("Ach"), noradrenaline ("NE"), and/or serotonin ("5-HT") or analogues thereof. Inhibitory transmitters would include primary gamma-aminobutyric acid ("GABA") or analogs thereof. Other amino acid transmitters known to affect the intralaminar nuclei, such as adenosine or glutamate, can also be used.

35 [0026] The electrode can be contacted with the patient's intralaminar nuclei by the methods conventionally employed for embedding or emplacing electrodes for deep brain electrical stimulation in other thalamic nuclei. Such methods are described in Tasker et al., "The Role of the Thalamus in Functional Neurosurgery," Neurosurgery Clinics of North America, 6(1):73-104 (1995) ("Tasker"). Briefly, the multi-polar electrode or electrodes are introduced via burr holes in the skull. The burr holes are placed based on the particular region of the intralaminar nuclei to be contacted. Preferably, prior to the introduction of the implantable multi-polar electrode(s), a detailed mapping with microelectrode and microstimulation following standard methods is carried out as described in Tasker, which is hereby incorporated by reference. Briefly, for each subdivision of the intralaminar nuclei, a preferred trajectory of approach optimizing the safety of entry point and maximal number of identifiable physiological landmarks in the responses of cell groups encountered along the trajectory into the desired region or regions of the intralaminar nuclei can be identified by one skilled in the art. This can be done, for example, by following the methods and catalogued physiological responses of different human thalamic cell groups described in Tasker. Initial mapping of the path for the stimulating electrode(s) can, therefore, be carried out via a combination of detailed single-unit recording of receptive field ("RF") properties of the cells encountered along the trajectory, projective fields ("PF") mapped by microstimulation of the same cell groups, and comparison with known RF and PF responses in the human thalamus. Similarly, evoked potentials can be recorded and, for the intralaminar nuclei, have several characteristic signatures identifiable from scalp surface recording as discussed in Velasco and Tasker, which are hereby incorporated by reference. For this mapping, microstimulation, using tungsten microelectrodes with impedances of roughly 1.5 megaohms, every 1 mm at threshold of up to 100 microamperes with short trains of 300Hz pulses of 0.2 millisecond pulse width are employed as described in Tasker, which is hereby incorporated by reference. Typically, an on-line data base of RF and PF information along the trajectory and stereotactic coordinates derived, for example, from Schaltenbrand et al., Introduction to Stereotaxis with an Atlas of the Human Brain, Stuttgart: Thieme (1977), or by computed mapping techniques, such as those described in Tasker et al., "Computer Mapping of Brainstem Sensory Centres in Man," J. Neurosurg., 44:458-464 (1976), can be used, either with or without a magnetic resonance imaging ("MRI")-based stereotactic apparatus. To carry out the above procedures, a patient would typically

remain conscious with application of local anesthesia or mild sedation. However, in cases where a patient is not sufficiently cooperative to remain conscious during the procedure, the above-described approach can be modified to allow the operation to be completed under general anesthesia.

**[0027]** The electrical stimulation can be continuous, intermittent, or periodic. The range of stimulation frequencies and intensity of stimulation will depend on several factors: impedance of the electrode once in the brain, excitation properties of cells which may differ within subdivisions of the intralaminar nuclei, the type of induced physiologic responses sought for a particular patient, and interindividual variation. While higher frequency ranges are thought to be preferred, lower frequencies will also be employed. Suitable stimulation frequencies range from about 1 Hz to 1 kHz; preferably, from about 10 Hz to about 500 Hz; and, more preferably, from about 50 Hz to about 250 Hz. However, higher frequencies can be utilized where amplitude or frequency modulated signals are used.

**[0028]** Typically, the electrode is connected to an insulated conductor which leads to an external connector plug which is removably connected to a mating plug which is, in turn, connected to a voltage control and pulse generator. The pulse generator produces a selected pulse train, and the voltage control provides a selected current amplitude or voltage to the waves of the pulse train. The signal pulse generator should preferably be capable of generating voltage wave trains of any desired form (sine, square wave, spike, rectangular, triangular, ramp, etc.) in a selectable voltage amplitude in the range from about 0.1 volts to about 10 volts and at selectable frequencies as set forth above. In practice, the pulse train and voltage amplitudes employed will be selected on a trial and error basis by evaluating a patient's response to various types and amplitudes of electrical stimulation over a time course of from about 1 to about 12 months. For example, after implanting the electrode in the patient's intralaminar nuclei, stimulation with a voltage within the range of from about 0.1 to about 10 volts or higher, a rate within the range of from about 50 to about 250 Hz, and a pulse width within the range of from about 50 to about 500 microseconds is applied for from about 8 to about 12 hours a day. During and after the implantation of the electrode, the parameters of the stimulation (voltage, pulse width, and frequency) are adjusted to optimize the patient's interactive behavior.

**[0029]** Intralaminar nuclei are a small set of nuclei located in the paramedian thalamus. The intralaminar nuclei can be divided into an anterior group and a posterior group. Figure 1 illustrates the anatomical connections of the intralaminar nuclei with distributed circuits underlying arousal, attention, intention, working memory, and gaze and motor control. The anterior group projects widely throughout the neocortex to primary sensory and motor areas and association cortices, while the posterior group projects mainly to sensory-motor and premotor areas and striatal targets. The anterior IL group includes the central lateral nucleus ("CL"), which projects to the frontal eye field ("FEF"), motor cortex, and, more heavily, to the posterior parietal cortex ("PPC"). The paracentral ("Pc") nucleus projects to the prefrontal cortex (with heavier projection than CL) and very strongly to the inferior parietal lobe and visual association cortices. The central medial ("CeM") nucleus, which also projects to the prefrontal and visual association cortices, also projects to the cingulate cortex and pregenual areas and to the medial cortical surface and orbitofrontal cortex. Included within the meaning of intralaminar nuclei, as used herein, is the Paraventricular nucleus ("Pv"), which is strongly associated with the limbic system, and midline thalamic nuclei. Projections to prefrontal cortex ("PFC") and anterior cingulate cortex arise, as well, from the anterior intralaminar group. The CL is also known to project to the primary visual cortex in the cat and monkey. The posterior group is dominated by the centromedian-parafascicularis complex ("Cm-Pf"), which strongly projects to areas 6 and 4. In primates, the Cm-Pf undergoes a notable expansion, and the CL also expands and develops further subdivisions. This system projects strongly to the caudate (from Pf), putamen (from Cm nuclei of the basal ganglia), and prefrontal and parietal association cortices. A small projection (Pf) also goes to the FEF. The intralaminar nuclei projections to the striatum per se are considered the principle efferent connections of the intralaminar nuclei and include anterior group projections to the caudate, as well. Thus, the intralaminar nuclei (including the midline nuclei) are believed to be in a preferred position to modulate the large thalamo-cortical-basal ganglia loops, especially to synchronize their function (Groenewegen et al., "The Specificity of the 'Nonspecific' Midline and Intralaminar Thalamic Nuclei," *Trends in Neuroscience* 17:52-66 (1994) ("Groenewegen").

**[0030]** The intralaminar nuclei receive ascending inputs from several components of the ascending reticular arousal system, including the pedunculo-pontine cholinergic group (lateral dorsal tegmentum), mesencephalic reticular formation, locus ceruleus, and dorsal raphe. Thus, the intralaminar nuclei are targets of modulation by a wide variety of neurotransmitter agents, including acetylcholine (pedunculo-pontine, lateral dorsal tegmentum, and mesencephalic reticular formation neurons), noradrenaline (locus ceruleus) serotonin (raphe nuclei), and histamine (hypothalamus). Also received by the intralaminar nuclei are nociceptive, cerebellar, tectal, pretectal, and rhinencephalic inputs. Descending inputs reciprocally relate components of the intralaminar nuclei with their cortical projections.

**[0031]** Although each cell group within the intralaminar nuclei projects to many separate cortical targets, each neuron of the intralaminar nuclei has a narrowly elaborated projection and receives its cortical feedback from the same restricted area. The reciprocal projections between the intralaminar nuclei and cortex have a distinctive laminar pattern that differs from the more well-known pattern of the reciprocal projections of the relay nuclei. The intralaminar nuclei neurons synapse in Layer I on the terminal dendritic tufts of layers III and V pyramidal cells and in layers V and VI, whereas neurons of the relay nuclei terminate primarily in cortical layers III and IV. Feedback to intralaminar nuclei

EP 1 191 972 B1

neurons originates in Layer V, but feedback to the relay nuclei originates in Layer VI. In the cat, the dominant cortico-thalamic input to the CL originates in the PFC, whereas the visual areas, including area 17, also project directly to the CL.

[0032] As used herein, intralaminar nuclei also include paralamellar regions, such as parts of the medial dorsal ("MD") nucleus and the midline nuclei (which are sometimes distinguished from the intralaminar nuclei but, for purposes of the present application, are not).

[0033] Figures 2A-2E illustrate intralaminar nuclei subdivisions suitable for stimulation in accordance with the practice of the present invention. Table 1 sets forth the meanings of the abbreviations used in Figures 2A-2E (See Buren et al., Variations and Connections of the Human Thalamus, New York: Springer-Verlag (1972)).

Table 1

Term		Sagittal	Horizontal	Transverse
A	— N. amygdalac	S — L 12.0-22.0		T — A 20.3 (PC)-10.9 (PC)
Ad	— N. anterodorsalis	S — L 3.0	H — S 13.2	T — A 20.3 (PC)-14.1 (PC)
A pr	— N. anteroprincipalis	S — L 3.0-9.0	H — S 13.2-6.3	T — A 23.4 (PC)-10.9 (PC). 4.7 (PC)
B	— N. basalis	S — L 6.0-22.0	H — I 4.5-8.1	T — A 23.4 (PC)-10.9 (PC)
B cj	— Brachium conjunctivum		H — I 8.1	
B co i	— Brachium colliculi inferioris	S — L 9.0	H — I 4.5	T — P 1.6 (PC), 4.7 (PC)
B co s	— Brachium colliculi superioris	S — L 9.0	H — I 4.5	
C cl s	— Corporis callosi splenium	S — L 2.0-3.0		
Cd	— N. caudatus	S — L 6.0, 12.0-25.0	H — S 17.0-13.2	T A 23.4 (PC)-P 4.7 (PC)
Ce me	— N. centralis magnocellularis	S — L 9.0	H — S 2.7	T — A 7.8 (PC)-1.6 (PC)
Cc pc	— N. centralis parvocellularis	S — L 9.0-12.0	H — S 6.3-1 0.9	T — A 7.8 (PC)-1.6 (PC)
Cl	— Claustrum		H — S 17.0, 9.7	T — A 23.4 (PC)
C m	— Corpus mammillare	S — I. 2.0, 2.5		T 14.1 (PC)
Cm a	— Commissura anterior	S — L 2.0, 6.0, 12.0-25.0	H — S 2.7-18.1	T — A 23.4 (PC) 17.2 (PC)
Cm p	— Commissura posterior	S — L 2.0, 3.0	H - S 2.7, 10.9	T — P 1.6 (PC)
Cn A	— Cornu Ammonis	S — L 19.0-25.0	H -- I 0.9, I 8.1	T — A 7.8 (PC)-1.6 (PC)
Co	— N. commissuralis	S — L 2.0-2.5	H — S 2.7	T — A 20.3 (PC)-10.9 (PC)
Co s	— Colliculus superior	S — L 2.0-6.0	H — I 0.9, 4.5	T — P 4.7 (PC)
D c	— N. dorsocaudalis	S — L 12.0-19.0	H — S 13.2, 9.7	T — A 7.8 (PC)-1.6 (PC)
D o	— N. dorsooralis	S — L 9.0-19.0	H — S 17.0-9.7	T — A 17.2 (PC)-7.8 (PC)
D sf	— N. dorsalis superficialis	S — L 6.0-12.0	H — S 17.0, 13.2	T — A 10.9 (PC)-4.7 (PC)
Edy	— N. endymalis	S — L 2.0, 2.5	H — 10.9	T — A 17.2 (PC)-10.9 (PC). 4.7 (PC)
F	— Fornix	S — L 2.0-3.0	H — S 17.0-1 8.1	T — A 23.4 (PC)-14.1 (PC). P 1.6 (PC), 4.7 (PC)
Fa	— N. fasciculosus	S — L 3.0, 6.0	H — S 2.7-1 0.9	T — A 23.4 (PC)-17.2 (PC)

EP 1 191 972 B1

Table 1 (continued)

Term		Sagittal	Horizontal	Transverse	
5	G l mc	— Corpus geniculatum laterale, magnocellularis	S — L 19.0-25.0	H — I 4.5, 8.1	T — A 1.6 (PC), P 1.6 (PC)
	G l pc	— Corpus geniculatum laterale, parvocellularis	S — L 19.0-25.0	H — I 4.5, 8.1	T — A 1.6 (PC), P 1.6 (PC)
10	G m mc	— Corpus geniculatum mediale, magnocellularis	S — L 12.0	H — I 4.5	T — P 1.6 (PC)
	G m pc	— Corpus geniculatum mediale, parvocellularis	S — L 12.0, 16.0	H — I 0.9, 4.5	T — A 1.6 (PC), P 1.6 (PC)
15	Gr ce	me — Grisea centralis mesencephali	S — L 2.0-3.0	H — I 4.5, 8.1	T — P 1.6 (PC), 4.7 (PC)
	cf H <sub>1</sub>	— Campus Forelii H <sub>1</sub>	S — L 6.0, 9.0	H — I 4.5	T — A 10.9 (PC)
	cf H <sub>2</sub>	— Campus Forelii H <sub>2</sub>	S — L 6.0, 9.0	H — I 4.5	T — A 10.9 (PC)
20	H l	— N. habcnularis lateralis	S — L 3.0	H — S 6.3, 2.7	T — A 1.6 (PC)
	H m	— N. habenularis medialis	S — L 2.0-3.0	H — S 6.3, 2.7	T — A 1.6 (PC)
	Hpth	— Hypothalamus	S — L 2.0-6.0	H — 10.9-8.1	T — A 23.4 (PC)-10.9 (PC)
25	ilLa	— N. intralamellaris	S — L 2.0-12.0	H — S 13.2-2.7	T — A 17.2 (PC)-1.6 (PC)
	I s	— N. interstitialis (Cajal)			T — A 1.6 (PC), P 4.7 (PC)
30	Li	— N. limitans	S — L 6.0-12.0	H — 10.9	T — P 1.6 (PC)
	L l	— Lemniscus lateralis			T — P 1.6 (PC), 4.7 (PC)
	L m	— Lemniscus medialis		H — I 4.5, 8.1	
	L po	— N. lateropolaris	S — L 6.0-16.0	H — S 13.2-10.9	T — A 23.4 (PC)-14.1 (PC)
35	M	— N. medialis	S — L 2.0-9.0	H — S 13.2-2.7	T — A 17.2 (PC)-1.6 (PC)
	N III	— N. oculomotorius	S — L 2.0		T — A 1.6 (PC)-P 4.7 (PC)
40	N V me	— N. nervi trigemini mesencephalicus			T — P 4.7 (PC)
	N EW	— N. Edinger Westphal	S — L 2.0		T — A 4.7 (PC)-P 4.7 (PC)
	Pf	— N. parafascicularis	S — L 6.0	H — I 0.9	T — A 7.8 (PC)-1.6 (PC)
45	Pi	— Pincal	S — L 2.0-3.0		T — P 4.7 (PC)
	P l	— Pallidum laterale	S — L 9.0-22.0	H — S 6.3-I 4.5	T — A 23.4 (PC)-7.8 (PC)
	P m	— Pallidum mediale	S — L 9.0-19.0	H — S 2.7-I 4.5	T — A 23.4 (PC)-10.9 (PC)
50	Pm a	— N. paramedianus anterior	S — L 2.0-2.5	H — S 2.7	T — A 20.3 (PC)-10.0 (PC)
	Pm p	— N. paramedianus posterior	S — L 2.0-2.5	H — S 2.7	T — A 7.8 (PC)-1.6(PC)
	P pd	— N. peripeduncularis	S — L 12.0	H — 14.5, 8.1	T — A 1.6 (PC)
55	Pret	— Area pretectalis	S — L 6.0	H — I 0.9, 4.5	T — P 1.6 (PC)
	Pr G	— N. praegeniculatus	S — L 19.0-22.0	H — I 4.5, 8.1	T — A 1.6 (PC)

EP 1 191 972 B1

Table 1 (continued)

Term		Sagittal	Horizontal	Transverse
5 Pt	— N. parataenialis	S — L 2.0-3.0	H — S 9.7-2.7	T — A 20.3 (PC)-7.8 (PC)
Pu i	— N. pulvinaris intergeniculatus	S — L 12.0	H — I 4.5	T — P 1.6 (PC)
Pu l	— N. pulvinaris lateralis	S — L 16.0-22.0	H — S 13.2-I 0.9	T — A 1.6 (PC)-P 4.7 (PC)
10 Pu m	— N. pulvinaris medialis	S — L 6.0-16.0	H — S 13.2-I 0.9	T — A 1.6 (PC)-P 4.7 (PC)
Pu o	— N. pulvinaris oralis	S — L 12.0	H — S 6.3, 2.7	T — A 1.6 (PC)
Put	— Putamen	S — L 19.0-25.0	H — S 13.2-I 8.1	T — A 23.4 (PC)-7.8 (PC)
15 Pv	— N. paraventricularis hypothalami	S — L 2.5, 3.0	H — I 0.9-8.1	T — A 23.4 (PC), 20.3 (PC)
R	— N. reticularis	S — L 6.0-25.0	H — S 17.0-I 0.9	T — A 23.4 (PC)-4.7 (PC), P 1.6 (PC), 4.7 (PC)
20 Ru	— N. ruber	S — L 2.0-6.0	H - I 4.5-8.1	T — A 7.8 (PC)-1.6 (PC)
S m th	— Stria medullaris thalami	S — L 2.0-3.0	H - S 9.7, 6.3	T — A 23.4 (PC)-1.6 (PC)
S n	— Substantia nigra	S — L 6.0-12.0	H — I 8.1	T — A 14.1 (PC)-1.6 (PC)
25 So	— N. supraopticus hypothalami	S — L 3.0-6.0, 12.0		T — A 23.4 (PC), 20.3 (PC)
Sth	— N. subthalamicus	S — L 6.0-12.0	H — I 4.5, 8.1	T — A 14.1 (PC)-7.8 (PC)
30 T l	— Nucleus tuberis lateralis	S — L 6.0		
T M	— Tractus Menerti	S — L 2.0-6.0	H - S 2.7-I 8.1	T — A 7.8 (PC)-1.6 (PC)
T m th	— Tractus mammillothalamicus	S — L 2.5-6.0	H — S 6.3-I 8.1	T — A 17.2 (PC), 14.1 (PC)
35 T O	— Tractus opticus	S — L 2.5-22.0		T — A 20.3 (PC)-4.7 (PC)
Vcc	— N. ventrocaudalis externus	S — L 16.0-19.0	H - S 9.7-I 0.9	T — A 7.8 (PC)-1.6 (PC)
40 Vci	— N. ventrocaudalis internus	S — L 12.0-16.0	H — S 6.3-I 0.9	T — A 7.8 (PC)-1.6 (PC)
V c pc	— N. ventrocaudalis parvocellularis	S — L 9.0-12.0	H — I 0.9	T — A 7.8 (PC), 4.7 (PC)
Vcv	— N. ventrocaudalis ventralis	S — L 16.0	H — I 4.5	T — A 7.8 (PC)-1.6 (PC))
45 V im	— N. ventrointermedius	S — L 9.0-19.0	H — S 6.3-I 0.9	T — A 10.9 (PC)-4.7 (PC)
Voe	— N. ventrooralis externus	S — L 9.0-16.0	H - S 13.2-I 0.9	T — A 17.2 (PC)-7.8 (PC)
50 Voi	— N. ventrooralis internus	S — L 6.0	H — S 9.7-I 0.9	T — A 14.1 (PC), 10.9 (PC)
Z i	— Zona incerta	S — L 6.0-16.0	H — I 4.5	T — A 17.2 (PC)-4.7 (PC)

For example, the stimulated intralaminar nuclei subdivisions can include the centromedian-parafascicularis or the central lateral or both. Alternatively, the stimulated portion of the patient's intralaminar nuclei can be selected so that it does not include the centromedian-parafascicularis, the central lateral, or either the centromedian-parafascicularis or the cen-

tral lateral nuclei.

[0034] The electrical stimulation can be applied to the patient's entire intralaminar nuclei or to one or more portions of the patient's intralaminar nuclei. In addition to being applied to the patient's intralaminar nuclei or portion thereof, the electrical stimulation can also extend to other regions of the brain. Preferably, the electrical stimulation is applied only to the patient's intralaminar nuclei or portion thereof without stimulating other regions of the patient's brain. For example, the electrical stimulation can be applied to all portions of the patient's intralaminar nuclei except the centromedian-parafascicularis, except the central lateral, or except both the central lateral and centromedian-parafascicularis.

[0035] The apparatus of the present invention may be capable of stimulating one or more subdivisions of the patient's subcortical structures integrated in the generation and control of generalized efference copy signals. Electrical stimulation is again followed by detection of internally generated movement of the patient and, in response, control of the electric stimulation. In particular, the subdivision to be stimulated can be one which modulates the specific cognitive function which is impaired in the patient. For example, Table 2 sets forth various subdivisions of the intralaminar nuclei and the specific cognitive function with which each is associated.

Table 2

Specific ILN Subdivision	Cognitive Function Impairment
centromedian-parafascicularis	attention deficits, anosognosia, working memory deficits, intentional deficits, nonsensory neglect, akinesia, frontal lobe damage
central lateral	perceptual impairment, sensory neglect, visuomotor impairment, working memory deficits, attentional deficits, anosognosia
paracentralis	working memory deficits, apathy, emotional dyscontrol
paraventricularis	loss of awareness of emotional/limbic signals
central medial	apathy, emotional dyscontrol, intentional deficits

[0036] Further details regarding the identification of intralaminar nuclei subdivisions which modulate specific cognitive function can be found in, for example, Macchi et al., "The Thalamic Intralaminar Nuclei and the Cerebral Cortex," pp. 355-389, in Jones et al., eds., Cerebral Cortex, Vol. 5, New York:Plenum Press (1986), Castaigne et al., "Paramedian Thalamic and Midbrain Infarcts: Clinical and Neuropathological Study," Ann. Neurol., 10:127-148 (1980), and Purpura et al., "The Thalamic Intralaminar Nuclei: A Role in Visual Awareness," The Neuroscientist, 3:8-15 (1997) ("Purpura"). Thus, by knowing the specific cognitive function or functions impaired in a particular patient, the preferred subdivision of the particular patient's intralaminar nuclei to receive electrical stimulation can be determined.

[0037] In cases where the patient suffers from post-encephalitic parkinsonism or other disease processes which include oculogyric crises as a symptom, it is believed that the preferred intralaminar nuclei subdivision is the central medial.

[0038] Once the particular subdivision to be stimulated is selected, that subdivision and, optionally, others are stimulated as described above. That is, electrical stimulation can be applied to the selected subdivision only, or, alternatively, electrical stimulation can be applied to the selected subdivision as well as other subdivisions of the patient's intralaminar nuclei. Stimulation can be applied to the selected subdivision and optional other subdivisions of the intralaminar nuclei in either or both brain hemispheres.

[0039] Preferably, the intralaminar nuclei subdivision which is to receive electrical stimulation is one which projects to an area of the brain which has reduced baseline function but which also exhibits increased function during periods of external stimulation or internally generated stimulation, such as patient's self-generated activity (e.g., head turning).

[0040] In many cases, patients with cognitive impairments following brain injury can have their cognitive function modulated by various forms of external stimulation. For example, in some patients, stimulation of the brainstem vestibular system with cold water caloric stimulation of the external ear canal, such as described in Gainotti, "The Role of Spontaneous Eye Movements in Orienting Attention and in Unilateral Neglect," pp. 107-113, in Robertson et al., eds., Unilateral Neglect: Clinical and Experimental Studies, Hove, United Kingdom:Lawrence Erlbaum Associates, Publishers (1993) and Vallar et al., "Modulation of the Neglect Syndrome by Sensory Stimulation," pp. 555-578, in Thier et al., eds., Parietal Lobe Contributions to Orientation in 3D Space, Heidelberg, Germany:Springer-Verlag (1997) ("Vallar"), generates transient but profound recovery of multiple cognitive functions including self-awareness, intention, and perceptual awareness. Other external stimulation that may modulate cognitive function, would include alteration of trunk, head, or limb position signals, such as a vibrational stimulation of the sternocleidomastoid muscle.

[0041] Similarly, some patients with less severe global impairments of consciousness discover strategies to self-generate behaviors that assist in supporting their cognitive or perceptual function. For example, some patients with visual agnosias who have visual perceptual problems discover that self-generated rhythmic head movements or hand

tracing movements improve their visual awareness and cognitive skills in identifying figures. These self-generated rhythmic head and hand movements are described in Farah, Visual Agnosia, Cambridge, Massachusetts:MIT Press (1990).

[0042] It is believed that the capacity to modulate cognitive function by external or internal stimulation in these patients demonstrates that certain brain activations can optimize their function. In the case of vestibular stimulation, it is believed that the intralaminar nuclei are directly implicated by their strong inputs from the vestibular nuclei. Although the present invention is not intended to be limited by the mechanism by which it operates, it is believed that the intralaminar nuclei's role in supporting these function relates to the generation of event-holding functions that may promote interaction across the cortex, possibly by enhancing synchronization, as described in Purpura. One theory of the present invention is that similar event-holding functions tied to head, hand, trunk, or other bodily coordinates are generated by intralaminar nuclei stimulation and account for the improved cognitive function seen in patients who are externally or internally stimulated. Whether or not such other modulations are directly tied to intralaminar nuclei stimulation, functional studies in an individual patient, such as those carried out in Bottini et al, "Modulation of Conscious Experience by Peripheral Sensory Stimuli," Nature, 376:778-781 (1995), can be used to identify specific cortical regions that are modulated as an initial step in applying the method of the present invention.

[0043] Although the above described method for selecting a subdivision of the patient's intralaminar nuclei to which to apply electrical stimulation is acceptable, in many cases, it is preferred to determine, on a individual basis, which areas of the brain have reduced baseline function, and then to correlate the area of the brain having reduced baseline function with an intralaminar nuclei subdivision which projects thereto. As one skilled in the art would recognize, determining areas of the brain which have reduced baseline function can be carried out advantageously using quantitative metabolic information obtained from a FDG-PET study of resting brain metabolism; using electromagnetic indicators of regional functional activity; anatomically, physiologically, or metabolically; or using combinations of these methods. As used herein, baseline brain function is defined within the patient and across a database of normal values for resting cerebral metabolism and is typically measured in terms of glucose uptake and utilization. One particularly useful gauge of baseline brain function is the regional cerebral metabolic rate as measured using fluorodeoxyglucose ("rCMRgluc"). This is quantitated by fluorodeoxyglucose-PET measurements and compared across brain structures within the patient's brain and against normative values for particular brain regions. Further details regarding assessing baseline brain function are described in, for example, Mazziota, ed., Clinical Brain Imaging, CNS Series, Philadelphia:Davis (1992).

[0044] Once the portion of the brain having reduced baseline function is identified, the portion can be correlated with the intralaminar nuclei ("ILN") subdivision which projects to this region, for example, by using Table 3.

Table 3

Specific ILN Subdivision	Primary Cortical Targets
centromedian-parafascicularis	prefrontal cortex, premotor cortex, parietal cortex
central lateral	prefrontal cortex, parietal cortex, visual association cortex, motor cortex
paracentralis	prefrontal cortex, orbitofrontal cortex
paraventricularis	amydala, limbic system
central medial	orbitofrontal cortex
paralam MD	prefrontal cortex
midline nuclei	hippocampus, limbic system

[0045] Further details regarding the correlation of areas of the brain to the intralaminar nuclei subdivisions which project thereto can be found in, for example, Jones et al., eds., The Thalamus, Amsterdam:Elsevier (1995). When a subdivision is selected in this manner, electrical stimulation can be applied to the selected subdivision only, or, alternatively, it can be applied to the selected subdivision and, in addition, to other subdivisions of the patient's intralaminar nuclei.

[0046] As indicated above, electrical stimulation can be applied to the entire group of intralaminar nuclei or to one, two, or more specific subdivisions thereof. Stimulation can be applied to the one, two, or more specific subdivisions in either or both brain hemispheres. In some cases, it can be advantageous to apply electrical stimulation to two or more subdivisions of the intralaminar nuclei which modulate separate cortical regions. As used herein, cortical regions are considered to be separate when they are not contiguous on the cortical mantle or they are considered separate in function based on known anatomical or physiological characteristics of cells within their borders. For example, the patient's central medial and centromedian-parafascicularis intralaminar nuclei subdivisions, which respectively project

strongly to the orbitofrontal and premotor regions of the cortex, can be stimulated. Where two or more subdivisions of the intralaminar nuclei are stimulated, both can lie in the same thalamus. Alternatively, at least one of the two or more subdivisions of the intralaminar nuclei can lie in the left thalamus while at least one of the two or more subdivisions of the intralaminar nuclei lies in the right thalamus. Preferably, at least one of the two or more subdivisions and, more preferably, at least two of the two or more subdivisions of the intralaminar nuclei to which electrical stimulation is applied modulates the specific cognitive function which is impaired in the patient.

**[0047]** Where two or more subdivisions of the patient's intralaminar nuclei are electrically stimulated periodically and at the same frequency, such stimulation can be completely in phase, partially in phase and partially out of phase, or completely out of phase. When such stimulation is substantially entirely in phase, it is said to be synchronized. In a preferred embodiment of the present invention, the electrical stimulation applied to two or more subdivisions of the patient's intralaminar nuclei is synchronized. It is believed that activation of separate cortical regions by common intralaminar nuclei inputs promotes coordinated processing in these separated cortical regions because of the strong capacity of these intralaminar inputs to generate depolarization of neurons in the supragranular layers (upper) of the cerebral cortex. It is believed that such strong depolarization generates improved synchronization of neuronal activity across cortical regions. This improved synchronization may result from high frequency oscillations excited by these inputs or sustained enhancement of neural activity seen in the form of broadband activity or increased average power across a cortical region. More particularly, the apparatus of the present invention can be optimized by monitoring regional and intrahemispheric changes in brain waves (e.g., changes in absolute power, relative power, and/or intra- and/or inter-regional coherence) as measured by using conventional techniques (e.g., electroencephalogram (EEG) or magnetoencephalogram (MEG techniques)) or by monitoring regional and intrahemispheric changes in metabolic activity. As indicated above, metabolic activity can be assessed using conventional methods (e.g., positron emission tomography ("PET") or FDG-PET).

**[0048]** The result of intralaminar nuclei stimulation under one aspect of the present invention is that correction of functional disconnections of brain regions by release of inhibition of remaining cortical or subcortical regions may be achieved by stimulation of the appropriately connected intralaminar nuclei; such release of inhibition may increase metabolic activity in suppressed areas. Alternatively, such stimulation may result in an alteration of population activity of many neurons in a local cortical area that improves information transfer or processing capacities of the neurons in that region (for example, by sharpening their receptive fields). Under another aspect of the present invention, synchronization of stimulated areas may facilitate a broader integration of cortical processing via synchronization of activity within the intralaminar nuclei of each thalamus and promote a global integrative process at the level of the cortex. Similarly, intralaminar nuclei connected to cortical areas known to be important for specific cognitive functions independent of a patient's particular injury, but selected by the patient's behaviorally evidenced impairment, may be selected for stimulation.

**[0049]** Selection of a particular strategy of intralaminar nuclei stimulation for a given patient will depend on several features including the specific cortical regions a given subdivision of the intralaminar nuclei projects to, particular stimulation parameters, evidence of modulation of cognitive function by external stimulation, internally generated stimulation (e.g., head turning), or spontaneously, and the patient's underlying brain damage and/or behavioral dysfunction. Optimization of the apparatus of the present invention involves promoting coordinated information processing or enhanced participation in integrated brain function of cortical regions innervated by intralaminar nuclei. If possible, this optimization can be based on evidence of improved function with reliable external (or internal) stimulation procedures or indexed by strong clinical inferences and functional anatomic information based on areas of identified hypometabolism or anatomical disconnection.

**[0050]** As one skilled in the art will recognize, optimization of the apparatus of the present invention can be achieved by varying specific stimulation parameters (such as intensity, frequency, pulse width, on time and off time, and duty cycle) while monitoring cognitive function as assessed by standard neuropsychologic instruments of working memory, attention, and/or intention. Optimization can also be effected by monitoring specific regional and intrahemispheric changes in distribution of signal power and coherence within the frequency spectrum.

**[0051]** It is believed that the mechanism which permits treatment of patients having impaired cognitive function with electrical stimulation of his or her intralaminar nuclei is based, in part, on applicants' newly theorized role for the intralaminar nuclei in cognitive operations, which is set forth in Purpura. Although the present invention is not meant in any way to be limited by the mechanism in which it operates, for example, as set forth in Purpura, it is believed that the proposed mechanism may assist in optimizing the apparatus of the present invention.

**[0052]** In another aspect of the present invention, coordination of function across cortical regions in a patient is improved by applying electrical stimulation to two or more subdivisions of the patient's intralaminar nuclei. Improved coordination of function across cortical regions, as used herein, is meant to include improved functional interactions of specific cortical regions within and across left and right hemispheres, such as those discussed above in regard to the effects of vestibular stimulation. In this aspect, the two or more subdivisions of the patient's intralaminar nuclei modulate separate cortical regions. Preferably, the electrical stimulation applied to the two or more subdivisions of the

intralaminar nuclei is synchronized or periodic, more preferably, synchronized and periodic. Suitable frequencies for use in the method of this aspect of the present invention range from about 1 Hz to 1 kHz; preferably, from about 10 Hz to about 500 Hz; and, more preferably, from about 50 Hz to about 250 Hz.

**[0053]** Several possible mechanisms may explain the improved coordination of function across cortical regions which is believed to result from application of electrical stimulation to two or more subdivisions of the patient's intralaminar nuclei. These include changes in global dynamics of a distributed neural network, changes in inhibition or excitation at one or more points in large loops of circuits activated by ILN inputs, and increases in metabolic rates that change the firing rates or other cellular processes. Also, increases in synchrony may promote increased firing rate and increased metabolism or vice versa.

**[0054]** In carrying out the present invention, electrical stimulation to at least a portion of the patient's subcortical structures is carried out in response to internally generated saccadic eye movement of the patient.

**[0055]** An advantage of the present invention is that the feedback used to control electrical stimulation of the patient's subcortical structures can also be augmented with non-electrical forms of stimulation. For example, auditory stimulation can be controlled as a function of such feedback with the auditory stimulation being used to activate other portions of the brain.

**[0056]** The present invention involves controlling electrical stimulation in response to saccadic eye movement. Feedback stimulation of specific parameters of oculomotor activity (e.g., saccade onset, intersaccadic interval onset) can be used to optimize intralaminar stimulation by providing a physiologically natural synchronizing pulse for intralaminar targets. Saccadic eye movements are also preferred, because of the widespread nature of the signal in the human brain.

**[0057]** In Figure 3, the general approach to implementation is shown with initial selection of intralaminar nuclei targets being performed based on clinical considerations. Feedback for intralaminar nuclei stimulation is based on saccadic eye-movement with or without additional pairing of other internally generated repetitive motoric activation (e.g., head turning, pointing, truncal rotation) or external stimulation (e.g., tone or vibratory stimulation). External stimulation pairing is intended to be augmentative. The advantage of pairing the stimulation with sensory stimuli is that coactivation of ascending pathways to primary and secondary sensory cortices that process these signals should allow a wider distribution of common phase marks (or synchronizing signals) to recruit partially impaired cortical regions when combined with activation of the intralaminar targets.

**[0058]** The feedback mechanism of the present invention can be used to control the intensity, frequency, pulse width, and time on/time off of stimulation. Further, the feedback efference copy signal can be used to provide either continuous feedback of endogeneous eye movements requiring indwelling hardware for the continuous monitoring and feedback of the eye movement signal or in a control training setting for rehabilitation where external eye movement monitoring and other monitors or internally generated movement of externally provided phase marks (e.g., tones, vibration etc.) could be paired. Therefore, under one aspect of this invention, the feedback stimulation to the intralaminar nuclei or related targets is akin to a neuronal pacemaker taking advantage of natural brain "beats" or envelopes of activations set by important transients such as the eye movement. In this mode, the feedback is continuous and is used as a brain pacemaker through the intralaminar nuclei and subcortical structures related to saccadic eye movement signals. The other mode is more general, allowing other internal or external phase marks to be coupled to intralaminar nuclei activation for the use of cognitive retraining.

**[0059]** Figure 4 provides a schematic of the hardware required for the implementation of the present invention. As shown in Figure 4, the stimulating electrode is directed at the thalamus of the patient with activation of the electrode being controlled by a feedback circuit - pulse generator. The feedback pulse generator operates in response to a saccade detection system. A saccade detection system is required to identify saccadic eye-movements and trigger the neurostimulation unit. Several external monitoring systems for saccadic eye movements are presently available and can be adapted for this purpose. Suitable systems include hardware for discrimination of electrooculogram activity or detection using infrared reflection from the pupil or Purkinje fibers (e.g., the ASL E5000 system (Applied Science Laboratories, Bedford, Massachusetts)). Other methods to detect saccadic eye movements include implanted electrodes to detect electrooculograms, electromyograms, or presaccadic potentials in the electroencephalogram or combinations thereof.

**[0060]** Figure 5 details the time sequence of saccadic eye movements and indicates two possible times for pulsed activation. In one alternative, stimulating pulses are initiated at the time of the saccadic eye movement. In the alternative embodiments, the stimulating pulse occurs during the intersaccadic interval.

**[0061]** Figure 6A shows a more detailed schematic of efference copy synchronization of stimulation based on saccadic eye movements. In Part I, eye position is calculated with an infrared camera (e.g., ASL E5000). Parts II and III calculate the magnitude of the change in eye-position over time. This allows the speed of the eye movement to be identified. In part IV, this speed is compared to a threshold to determine when stimulation should be initiated.

**[0062]** Figure 6B illustrates an example of an eye position signal as it is processed to identify the onset of a saccade and stimulation in response to the saccade. The signals corresponding to each of parts I-IV of Figure 6A are shown in Figure 6B. In the first panel (I), horizontal eye positions over time are displayed. In the second panel (II), horizontal

velocity has been calculated by the change in horizontal position divided by a 5 millisecond time interval between sampling of positions. In panel III, the absolute value of the velocity (shown in panel II) is plotted along with a threshold for identifying saccadic eye movements (solid line at -20 degrees/sec). Finally, in panel IV, the starting points of ILN stimulation as triggered at the switch are displayed. Alternative circuit designs would include acceleration triggered circuits or other trigger signals, such as waveforms, if EOG, (electrooculogram-electrical potential change associated with eye movement), EMG (electromyogram-electrical potential changes of the muscles), or EEG saccade related activity is monitored in part IV of Figure 6A which controls the stimulator.

**[0063]** Eye-movement feedback is further proposed in conjunction with paired activation of other sensory channels (e.g., auditory) or motor gating signals (e.g., head or truncal rotations). Several studies show evidence that intrinsic sequences of brain activation are linked tightly to saccadic eye-movements. In addition, several examples of cognitive improvement are noted in patients who engage in rhythmic head or hand movements, truncal rotation or neck vibration (Vallar). Recent evidence demonstrates that even phasic alerting with pure tones can improve sensory inattention. The intralaminar nuclei-midline system may gate long-range cortico-cortical interactions by computing a generalized efference copy that includes dynamic coordinates for the integration of head, eye, body, and limb positions. The activation of the intralaminar nuclei is proposed to result in the formation of several areas of enhanced neuronal firing rate in both cerebral cortical and striatal structures ("event-holding functions") with an envelope of activation set by the timing of intralaminar nuclei pulses.

**[0064]** The intralaminar nuclei is the preferred target for deep brain stimulation for remediation of cognitive disabilities for several reasons outlined in U.S. Patent No. 5,938,688, filed December 4, 1997, including, importantly, the economy of one stimulation site activating several regionally selective cortical and subcortical targets to modulate their neuronal firing rates, metabolism, or behavioral expression of the networks they comprise. In patients who may otherwise be good candidates for this therapy, direct injury to the intralaminar nuclei or surrounding thalamic or white matter tissue may prevent the application of the described invention. The present invention has two purposes. One is to improve treatment by introducing feedback stimulation of the natural physiological signals computed in the intralaminar nuclei and passed to the cortical and subcortical targets. The other is to take advantage of secondary targets for deep brain stimulation using the feedback mechanism to provide a synchronizing pulse, particularly, or preferably in situations where the optimal intralaminar nuclei targets are not available.

**[0065]** An example of a practical situation where intralaminar nuclei stimulation, as described in U.S. Patent No. 5,938,688, filed December 4, 1997, would be prevented from having an optimal therapeutic effect is the patient described by De La Sayette et al., "Infarction in the Territory of the Right Choroidal Artery and Minor Hemisphere Syndrome: Case Report and Brain Glucose Utilization Study," *Rev. Neurol.* 151(1):24-35 (1995), with an infarction of the right anterior choroidal artery resulting in a "thalamic exclusion" syndrome with a severe metabolic deficit that persisted months after the injury. In this patient, vestibular stimulation demonstrated that residual functional activity could be recovered from the severely damaged right hemisphere. Using the invention disclosed here, it is proposed that paired feedback stimulation of the left intralaminar nuclei (central lateral or parafascicularis) and the right caudate nucleus (which demonstrated residual metabolism) would support a tonic reactivation of the functionally impaired right hemisphere. Excepting the right mesencephalic reticular formation, other right hemisphere targets in this patient were either severely damaged (globus pallidus) or anatomically disconnected (all thalamic targets-intralaminar nuclei and others).

**[0066]** Thus, combined use of feedback of the oculomotor signal to a deep brain stimulator can optimize the stimulation of the intralaminar nuclei-midline thalamic structures in cases where the preferred targets may not be available due to direct structural injuries or to indirect obstruction to the preferred implementation (e.g., direct thalamic injury, loss of white matter connection, neoplastic change in path of electrode, etc). Feedback stimulation of part of the intralaminar nuclei and additional related subcortical structures receiving direct intralaminar nuclei innervation such as the caudate, putamen, or responding to saccadic eye movements such as globus pallidus interna, dorsal median or pulvinar thalamic nuclei or pretectum, mesencephalic reticular formation or superior colliculus could in this way be combined with intralaminar nuclei targets. See Leigh et al., *The Neurology of Eye Movement* (Oxford Univ. Press 1999).

**[0067]** The activation of specific intralaminar targets (i.e. central lateral, paracentralis, and the centromedian-parafascicularis complex) driven by continuous parameters of the patient's endogenous eye movements (i.e. saccades, microsaccades) can also be used to optimize intralaminar nuclei stimulation for the purpose of remediating cognitive disability. Such activation may be based on voluntary eye movements in training sequences as well as continuous feedback of endogenous eye movements. Neuronal populations mediating voluntary versus learning automatic saccadic sequences (e.g., main sequence of saccades (Hayhoe et al. "Task Constraints in Visual Working Memory," *Vision Res.* 38(1):125-37 (1998) ("Hayhoe")), or reading (see Reichle et al., "Toward a Model of Eye Movement Control in Reading," *Psychol. Rev.* 105(1):125-57 (1998)), and efficacy of feedback would likely vary on basis of underlying brain injury. Using the feedback circuit to the neurostimulation unit in conjunction with voluntary saccades, training paradigms may be used for intervals to selectively pair eye-movement feedback with visuomotor activity (Hayhoe), perceptual retraining (Robertson et al., "Prospects for the Rehabilitation of Unilateral Neglect," in Robertson et al., *Unilateral Neglect: Clinical and Experimental Studies* (1993)), or memory formation retrieval (Kinsbourne, "Eye and Head Turning

Indicates Cerebral Lateralization," *Science* 176:539-41 (1972) and Purpura et al., "The Thalamic Intralaminar Nuclei: A Role in Visual Awareness, *Neurosci* pp. 8-15 (1997) ("Purpura").

[0068] One theory of the present invention is that intralaminar nuclei activation of multiple cortical and subcortical regions is generated as the result of computing a generalized efference copy signal. By definition, an efference copy is an internal copy of a motor innervation (von Holst et al., "Das Reafferenzprinzip. Wechselwirkungen zwischen Zentral Nerven System und Peripheries," *Naturwissenschaften* 37:464-76 (1950) and Bridgeman, "A Review of the Role of Efference Copy in Sensory and Oculomotor Control System," *Ann. Biomed. Eng.* 23:409-22 (1995)), and, as such, is the control signal used by a system to organize its behavior. One example of such signalling is the unique reporting of central lateral nucleus intralaminar neurons of oculomotor function (Schlag-Rey et al., "Visumotor Functions of Central Thalamus in Monkey. I. Unit Activity Related to Spontaneous Eye Movements," *J. Neurophysiol.* 40:1149-74 (1984) and Purpura). Other types of efference copy are also associated with the intralaminar nuclei such as rhythmic motor behavior and verbal fluency (Mennemeier et al., "Tapping, Talking, and the Thalamus: Possible Influence of the Intralaminar Nuclei on Basal Ganglia Function," *Neuropsych.* 35(2):183-93 (1997)). Intralaminar nuclei activations are thought to activate and synchronize several parallel thalamocortical basal ganglia loops (Gronewegen). In the present invention, known vestibular, oculomotor, auditory, somatosensory, and other afferents to the intralaminar nuclei are combined and translated as generalized efference copy to selectively activate functional collections of cortical and striatal targets. Feedback of internally generated saccadic eye movements is proposed to enhance the functional recovery of impaired cerebral regions by deep brain stimulation of the intralaminar nuclei by providing a physiological natural synchronizing pulse to these regions and their target structures. By enhancing the internal efference copy signal and rechanneling these signals to other brain structures prepared to accept the activation, reintegration of impaired (but potentially functional) networks will be promoted.

## Claims

1. A cognitive function improving apparatus comprising:

(i) means for applying electrical stimulation to at least a portion of a patient's subcortical structures involved in the generation and the control of generalised efference copy signals under conditions effective to improve the patient's cognitive function;

(ii) means for detecting internally generated saccadic eye movement of the patient; and

(iii) means for controlling the applied electrical stimulation in response to detected internally generated saccadic eye movement of the patient.

2. A cognitive function improving apparatus according to Claim 1 wherein the means for controlling the applied electrical stimulation is capable of providing continuous, intermittent or periodic stimulation.

3. A cognitive function improving apparatus according to Claim 1 which is capable of patient biofeedback.

4. A cognitive function improving apparatus according to Claim 1 wherein the means for controlling the applied electrical stimulation in response to detected internally generated saccadic eye movement of the patient is capable of controlling at least one of the parameters of intensity, frequency, pulse width and the time on and time off of the applied electrical stimulation.

5. A cognitive function improving apparatus according to any preceding claim wherein the means for controlling the applied electrical stimulation comprises a pulse generator.

6. A cognitive function improving apparatus according to Claim 5 wherein the pulse generator is capable of generating voltage wave trains selected from sine, square, spike, rectangular, triangular or ramp.

7. A cognitive function improving apparatus according to any preceding claim wherein the means for applying electrical stimulation to at least a portion of an individual's subcortical structures involved in the control of generalised efference copy signals comprises an electrode capable of delivering an electrical signal to a patient's intralaminar nuclei.

8. A cognitive function improving apparatus according to Claim 7 wherein the electrode is capable of applying electrical stimulation at a frequency of from 1 Hz to 1 kHz.

## EP 1 191 972 B1

9. A cognitive function improving apparatus according to Claim 8 wherein the electrode is capable of applying electrical stimulation at a frequency of from 10 Hz to 500 Hz.
- 5 10. A cognitive function improving apparatus according to Claim 9 wherein the electrode is capable of applying electrical stimulation at a frequency of from 50 Hz to 250 Hz.
- 10 11. A cognitive function improving apparatus according to any one of Claims 7 to 9 wherein the electrode is capable of delivering an electrical signal to at least a selected subdivision of the patient's intralaminar nuclei, which subdivision modulates a specific cognitive function.
12. A cognitive function improving apparatus according to Claim 11 wherein the electrode is capable of delivering an electrical signal only to the selected subdivision.
- 15 13. A cognitive function improving apparatus according to any preceding claims wherein the means for applying electrical stimulation to at least a portion of a patient's subcortical structures involved in the control of generalised efference copy signals is capable of applying electrical stimulation to two or more subdivisions of a patient's intralaminar nuclei which modulate separate cortical regions.
- 20 14. A cognitive function improving apparatus according to Claim 13 which is capable of applying electrical stimulation to two or more subdivisions of a patient's intralaminar nuclei which modulate separate cortical regions in a synchronized manner.
- 25 15. A cognitive function improving apparatus according to Claim 14 further comprising means capable of identifying regional or intrahemispheric changes in brain waves in response to the applied electrical stimulation to two or more subdivisions of a patient's intralaminar nuclei.
- 30 16. A cognitive function improving apparatus according to Claim 7 wherein the electrode is an implantable multipolar electrode comprising an implantable pulse generator that is a radiofrequency controlled device operatable by an external transmitter.
- 35 17. A cognitive function improving apparatus according to Claim 7 wherein the implantable multipolar electrode contacts allow for adjustment of frequency, amplitude and pulse width.
18. A cognitive function improving apparatus according to Claim 17 wherein the implantable multipolar electrode contacts allow for adjustment of frequency within the range of about 2-200Hz, the adjustment of amplitude within the range of about 0.1-10 Volts and the adjustment of pulse width within the range of about 50-500 microseconds.
- 40 19. A cognitive function improving apparatus according to Claim 7 wherein the implantable multipolar electrode is a Medtronic 3387 electrode.
- 45 20. A cognitive function improving apparatus according to any one of Claims 4 to 19 wherein the electrode is capable of delivering pharmacological agents to a patient's subcortical structures.
21. A cognitive function improving apparatus according to Claim 20 wherein the electrode has microcannulae suitable for delivering pharmacological agents to a patient's subcortical structures.
- 50 22. A cognitive function improving apparatus according to Claim 20 or 21 further comprising a pharmacological agent.
23. A cognitive function improving apparatus according to Claim 22 wherein the pharmacological agent is an excitatory or inhibitory transmitter that is capable of influencing intralaminar nuclei function.
- 55 24. A cognitive function improving apparatus according to Claim 22 wherein the pharmacological agent is selected from acetylcholine, noradrenaline, serotonin, gamma-aminobutyric acid or analogues thereof.
25. A cognitive function improving apparatus according to Claim 22 wherein the pharmacological agent is an amino acid transmitter that is capable of influencing intralaminar nuclei function.
26. A cognitive function improving apparatus according to Claim 25 wherein the pharmacological agent is selected

from adenosine or glutamate.

27. A cognitive function improving apparatus according to any preceding claim further comprising means for non-electrical stimulation of a patient.

28. A cognitive function improving apparatus according to Claim 27 wherein the means for non-electrical stimulation of a patient is a means capable of auditory stimulation of a patient.

29. A cognitive function improving apparatus according to any of the preceding Claims wherein the means for detecting internally generated saccadic eye movement of the patient is a camera.

30. A cognitive function improving apparatus according to any of the preceding Claims wherein the means for detecting saccadic eye movement is selected from:

(i) hardware capable of discrimination of electrooculogram activity or detection using infrared reflection from the pupil or Purkinje fibres; or

(ii) electrodes suitable for implantation and, when so implanted, capable of detection of electrooculograms, electromyograms, presaccadic potentials in the electrocephalogram or combinations thereof.

31. A cognitive function improving apparatus according to any of Claims 13-15 for improving coordination of function across cortical regions in a patient.

#### Patentansprüche

1. Vorrichtung zur Verbesserung der kognitiven Funktion, mit:

(i) einem Mittel zum Anlegen einer elektrischen Stimulierung an mindestens einen Teil der subkortikalen Strukturen eines Patienten, die bei der Erzeugung und der Steuerung von allgemeinen Efferenz-Kopiesignalen unter bei der Verbesserung der kognitiven Funktion des Patienten wirksamen Bedingungen beteiligt sind,

(ii) einem Mittel zum Erfassen einer intern hervorgerufenen, ruckartigen Augenbewegung des Patienten, und

(iii) einem Mittel zum Steuern der angelegten elektrischen Stimulierung in Reaktion auf eine erfasste, intern hervorgerufene, ruckartige Augenbewegung des Patienten.

2. Vorrichtung zur Verbesserung der kognitiven Funktion nach Anspruch 1, wobei das Mittel zum Steuern der angelegten elektrischen Stimulierung eine kontinuierliche, intermittierende oder periodische Stimulierung liefern kann.

3. Vorrichtung zur Verbesserung der kognitiven Funktion nach Anspruch 1, die zu einem Patienten-Biofeedback fähig ist.

4. Vorrichtung zur Verbesserung der kognitiven Funktion nach Anspruch 1, wobei das Mittel zum Steuern der angelegten elektrischen Stimulierung in Reaktion auf erfasste, intern hervorgerufene, ruckartige Augenbewegung des Patienten mindestens einen der Parameter Intensität, Frequenz, Impulsbreite und Einschalt- und Ausschaltzeit der angelegten elektrischen Stimulierung steuern kann.

5. Vorrichtung zur Verbesserung der kognitiven Funktion nach einem der vorangehenden Ansprüche, wobei das Mittel zum Steuern der angelegten elektrischen Stimulierung einen Impulsgenerator umfasst.

6. Vorrichtung zur Verbesserung der kognitiven Funktion nach Anspruch 5, wobei der Impulsgenerator Spannungs- wellen-Abfolgen erzeugen kann, die aus Sinus-Quadrat-, Zacken-, Rechteck-, Dreieck- oder Rampenwellen ausgewählt sind.

7. Vorrichtung zur Verbesserung der kognitiven Funktion nach einem der vorangehenden Ansprüche, wobei das Mittel zum Anlegen einer elektrischen Stimulierung an mindestens einen Teil der subkortikalen Strukturen einer Person, die bei der Steuerung von allgemeinen Efferenz-Kopiesignalen beteiligt sind, eine Elektrode umfasst, welche ein elektrisches Signal an die intralaminaren Nuklei eines Patienten liefern kann.

8. Vorrichtung zur Verbesserung der kognitiven Funktion nach Anspruch 7, wobei die Elektrode eine elektrische Sti-

## EP 1 191 972 B1

mulierung mit einer Frequenz von 1 Hz bis 1 kHz anlegen kann.

5 9. Vorrichtung zur Verbesserung der kognitiven Funktion nach Anspruch 8, wobei die Elektrode eine elektrische Stimulierung mit einer Frequenz von 10 Hz bis 500 Hz anlegen kann.

10 10. Vorrichtung zur Verbesserung der kognitiven Funktion nach Anspruch 9, wobei die Elektrode eine elektrische Stimulierung mit einer Frequenz von 50 Hz bis 250 Hz anlegen kann.

11. Vorrichtung zur Verbesserung der kognitiven Funktion nach einem der Ansprüche 7 bis 9, wobei die Elektrode ein elektrisches Signal an mindestens eine ausgewählte Untereinheit der intralaminaren Nuklei des Patienten liefern kann, wobei die Untereinheit eine spezifische kognitive Funktion moduliert.

12. Vorrichtung zur Verbesserung der kognitiven Funktion nach Anspruch 11, wobei die Elektrode in der Lage ist, nur der ausgewählten Untereinheit ein elektrisches Signal zu liefern.

13. Vorrichtung zur Verbesserung der kognitiven Funktion nach einem der vorangehenden Ansprüche, wobei das Mittel zum Anlegen einer elektrischen Stimulierung an mindestens einem Teil der subkortikalen Strukturen eines Patienten, die bei der Steuerung von allgemeinen Efferenz-Kopiesignalen beteiligt sind, eine elektrische Stimulierung an zwei oder mehr Untereinheiten der intralaminaren Nuklei eines Patienten, welche separate Kortikalbereiche modulieren, anlegen kann.

14. Vorrichtung zur Verbesserung der kognitiven Funktion nach Anspruch 13, die eine elektrische Stimulierung an zwei oder mehr Untereinheiten intralaminarer Nuklei eines Patienten in synchronisierter Weise anlegen kann, welche separate Kortikalbereiche modulieren.

15 16. Vorrichtung zur Verbesserung der kognitiven Funktion nach Anspruch 14, ferner mit einem Mittel, das fähig ist, regionale Änderungen oder Änderungen unter den Gehirnhälften bei Gehirnwellen in Reaktion auf die angelegte elektrische Stimulierung an zwei oder mehr Untereinheiten der intralaminaren Nuklei eines Patienten zu identifizieren.

17. Vorrichtung zur Verbesserung der kognitiven Funktion nach Anspruch 7, wobei die Elektrode eine implantierbare, multipolare Elektrode ist, die einen implantierbaren Impulsgenerator aufweist, der ein mittels Radiofrequenz gesteuertes Gerät ist; welches durch einen externen Transmitter betätigbar ist.

18. Vorrichtung zur Verbesserung der kognitiven Funktion nach Anspruch 7, wobei die Kontakte der implantierbaren, multipolaren Elektrode eine Einstellung bzw. Anpassung der Frequenz, der Amplitude und der Pulsbreite ermöglichen.

19. Vorrichtung zur Verbesserung der kognitiven Funktion nach Anspruch 17, wobei die Kontakte der implantierbaren, multipolaren Elektrode eine Einstellung der Frequenz in dem Bereich von etwa 2 - 200 Hz, die Einstellung der Amplitude in dem Bereich von etwa 0,1 - 10 V sowie die Einstellung der Impulsbreite in dem Bereich von etwa 50 - 500 ms ermöglichen.

20. Vorrichtung zur Verbesserung der kognitiven Funktion nach Anspruch 7, wobei die implantierbare, multipolare Elektrode eine Medtronic-3387-Elektrode ist.

21. Vorrichtung zur Verbesserung der kognitiven Funktion nach einem der Ansprüche 4 bis 19, wobei die Elektrode pharmazeutische Wirkstoffe an die subkortikalen Strukturen eines Patienten liefern kann.

22. Vorrichtung zur Verbesserung der kognitiven Funktion nach Anspruch 20, wobei die Elektrode Mikrokanülen aufweist, die zum Liefern pharmazeutischer Wirkstoffe an die subkortikalen Strukturen eines Patienten geeignet sind.

23. Vorrichtung zur Verbesserung der kognitiven Funktion nach Anspruch 20 oder 21, ferner einen pharmazeutischen Wirkstoff umfassend.

24. Vorrichtung zur Verbesserung der kognitiven Funktion nach Anspruch 22, wobei der pharmazeutische Wirkstoff ein erregender oder hemmender Transmitter ist, der die Funktion intralaminarer Nuklei beeinflussen kann.

## EP 1 191 972 B1

24. Vorrichtung zur Verbesserung der kognitiven Funktion nach Anspruch 22, wobei der pharmazeutische Wirkstoff Acetylcholin, Noradrenalin, Serotonin, Gamma-Aminobuttersäure oder ein hierzu analoger Stoff ist.
- 5 25. Vorrichtung zur Verbesserung der kognitiven Funktion nach Anspruch 22, wobei der pharmazeutische Wirkstoff ein Aminosäuren-Transmitter ist, der die Funktion intralaminarer Nuklei beeinflussen kann.
26. Vorrichtung zur Verbesserung der kognitiven Funktion nach Anspruch 25, wobei der pharmazeutische Wirkstoff aus Adenosin oder Glutamat ausgewählt ist.
- 10 27. Vorrichtung zur Verbesserung der kognitiven Funktion nach einem der vorangehenden Ansprüche, ferner ein Mittel zur nicht-elektrischen Stimulierung eines Patienten umfassend.
28. Vorrichtung zur Verbesserung der kognitiven Funktion nach Anspruch 27, wobei das Mittel zur nicht-elektrischen Stimulierung eines Patienten ein Mittel ist, das das Gehör eines Patienten stimulieren kann.
- 15 29. Vorrichtung zur Verbesserung der kognitiven Funktion nach einem der vorangehenden Ansprüche, wobei das Mittel zum Erfassen einer intern hervorgerufenen, ruckartigen Augenbewegung des Patienten eine Kamera ist.
- 20 30. Vorrichtung zur Verbesserung der kognitiven Funktion nach einem der vorangehenden Ansprüche, wobei das Mittel zum Erfassen einer ruckartigen Augenbewegung ausgewählt ist aus:
- (i) Hardware, die zur Unterscheidung einer Elektro-Okulogramm-Aktivität oder zur Erfassung mittels Infrarot-Reflexion von der Pupille oder von Purkinje-Fasern fähig ist, oder
- 25 (ii) Elektroden, die zur Implantation geeignet sind, und wenn sie implantiert sind, zur Erfassung von Elektro-Okulogrammen, Elektro-Myogrammen, von vor-sarkkadischen Potentialen im Elektro-Enzephalogramm oder von Kombinationen derselben in der Lage sind.
31. Vorrichtung zur Verbesserung der kognitiven Funktion nach einem der Ansprüche 13 bis 15 zur Verbesserung der Koordination von Funktionen über Kortikalbereiche bei einem Patienten.
- 30

### Revendications

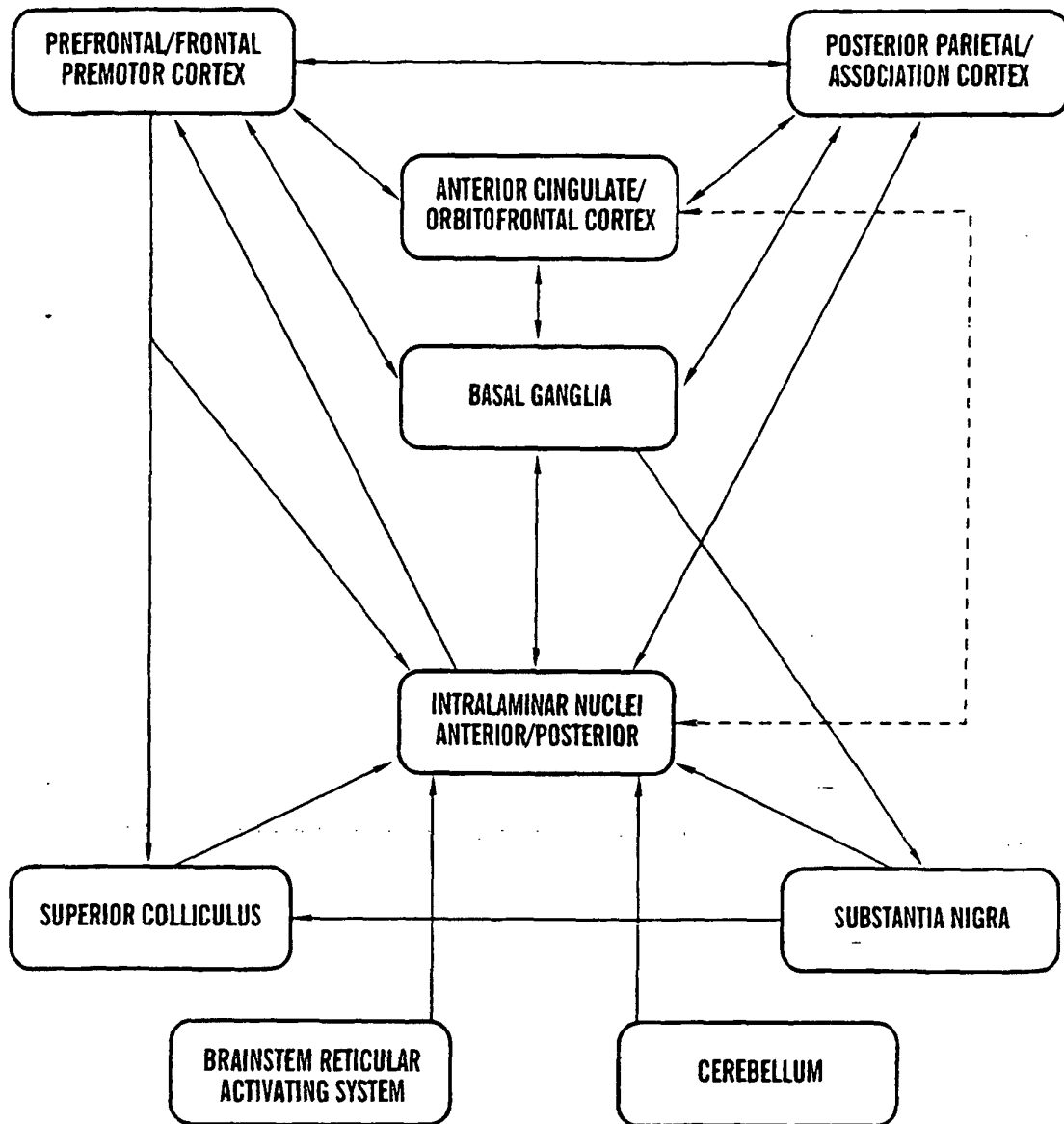
- 35 1. Appareil améliorant les fonctions cognitives comprenant :
- (i) des moyens pour appliquer une stimulation électrique à au moins une partie des structures sous-corticales d'un patient impliquées dans la génération et le contrôle de signaux de copie d'efférence généralisée, dans des conditions efficaces pour améliorer les fonctions cognitives du patient ;
- 40 (ii) des moyens pour détecter les saccades oculaires du patient générées de façon interne ; et
- (iii) des moyens pour contrôler l'application de la stimulation électrique en réponse à la détection des saccades oculaires du patient générées de façon interne.
2. Appareil améliorant les fonctions cognitives selon la revendication 1 dans lequel les moyens pour contrôler l'application de la stimulation électrique sont capables de fournir une stimulation continue, intermittente ou périodique.
- 45 3. Appareil améliorant les fonctions cognitives selon la revendication 1 qui est capable de rétroaction biologique du patient.
4. Appareil améliorant les fonctions cognitives selon la revendication 1 dans lequel les moyens pour contrôler l'application de la stimulation électrique en réponse à la détection de saccades oculaires du patient générées de façon interne sont capables de contrôler au moins un des paramètres d'intensité, de fréquence, de largeur d'impulsion et le début et la fin de l'application de la stimulation électrique.
- 50 5. Appareil améliorant les fonctions cognitives selon l'une quelconque des revendications précédentes dans lequel les moyens pour contrôler l'application de la stimulation électrique comprennent un générateur d'impulsion.
- 55 6. Appareil améliorant les fonctions cognitives selon la revendication 5 dans lequel le générateur d'impulsion est capable de générer des trains d'ondes de potentiel choisis à partir des formes sinusoïdales, carrées, en pointes,

rectangulaires, triangulaires ou rampées.

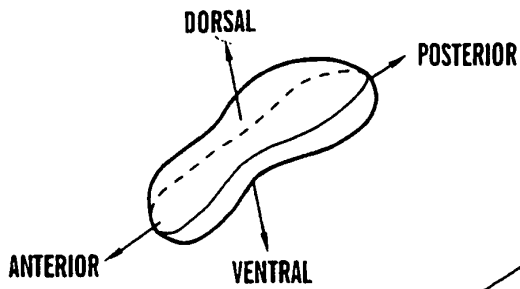
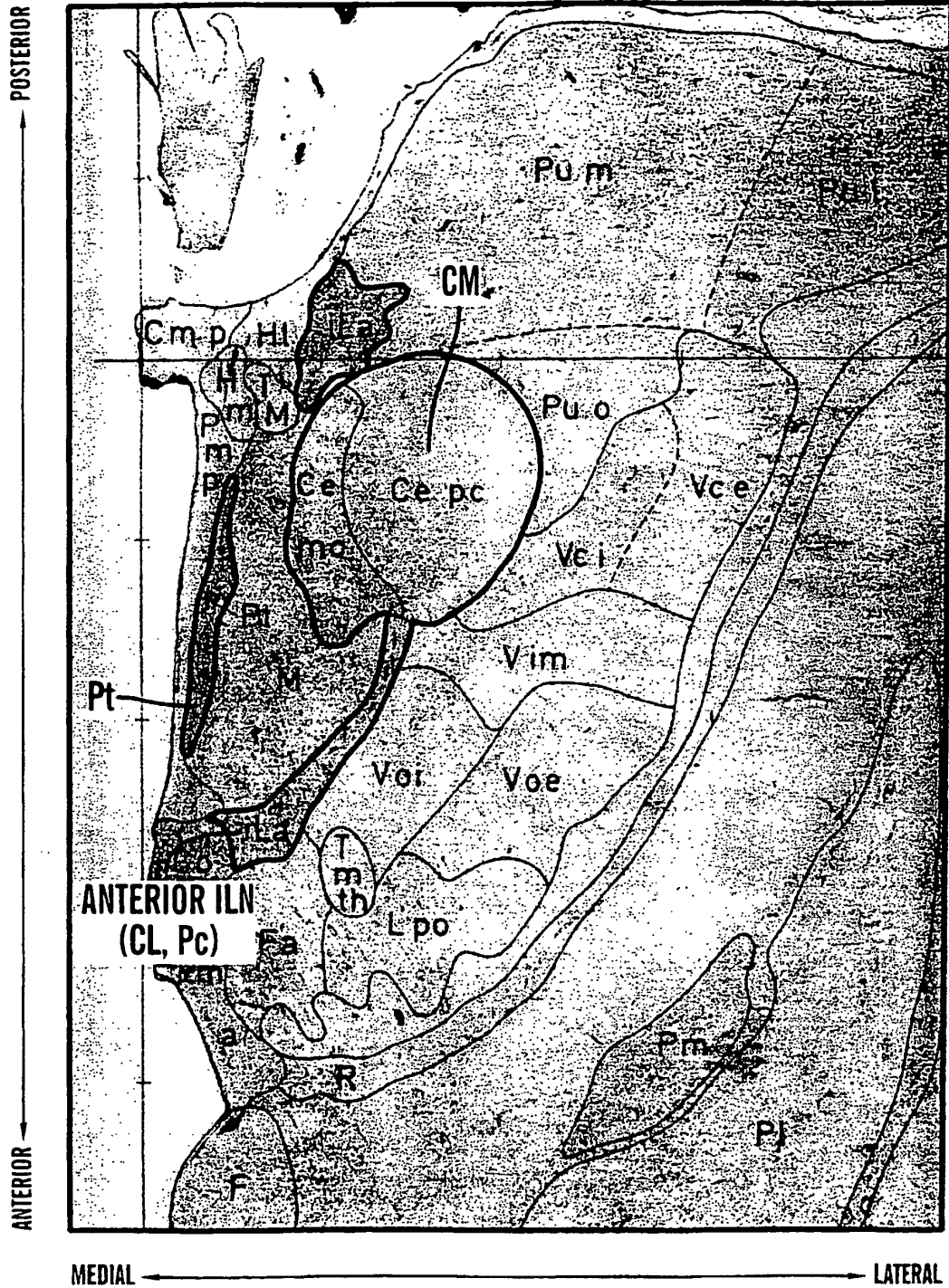
- 5
7. Appareil améliorant les fonctions cognitives selon l'une quelconque des revendications précédentes dans lequel les moyens pour appliquer une stimulation électrique sur au moins une partie des structures sous-corticales du sujet impliquées dans le contrôle de signaux de copie d'efférence généralisée comprennent une électrode capable de délivrer un signal électrique aux noyaux intralaminaires du patient.
- 10
8. Appareil améliorant les fonctions cognitives selon la revendication 7 dans lequel l'électrode est capable d'appliquer une stimulation électrique à une fréquence comprise entre 1 Hz et 1 kHz.
- 15
9. Appareil améliorant les fonctions cognitives selon la revendication 8 dans lequel l'électrode est capable d'appliquer une stimulation électrique à une fréquence comprise entre 10 Hz et 500 Hz.
- 20
10. Appareil améliorant les fonctions cognitives selon la revendication 9 dans lequel l'électrode est capable d'appliquer une stimulation électrique à une fréquence comprise entre 50 Hz et 250 Hz.
- 25
11. Appareil améliorant les fonctions cognitives selon l'une des revendications 7 à 9 dans lequel l'électrode est capable de délivrer un signal électrique à au moins une subdivision choisie des noyaux intralaminaires du patient, laquelle subdivision module une fonction cognitive spécifique.
- 30
12. Appareil améliorant les fonctions cognitives selon la revendication 11 dans lequel l'électrode n'est capable de délivrer un signal électrique qu'à la subdivision choisie.
- 35
13. Appareil améliorant les fonctions cognitives selon l'une quelconque des revendications précédentes dans lequel les moyens pour appliquer une stimulation électrique sur au moins une partie des structures sous-corticales du patient impliquées dans le contrôle de signaux de copie d'efférence généralisée sont capables d'appliquer une stimulation électrique sur deux subdivisions ou plus des noyaux intralaminaires du patient qui modulent des zones corticales distinctes.
- 40
14. Appareil améliorant les fonctions cognitives selon la revendication 13 qui est capable d'appliquer une stimulation électrique sur deux subdivisions ou plus des noyaux intralaminaires du patient qui modulent des zones corticales distinctes de façon synchrone.
- 45
15. Appareil améliorant les fonctions cognitives selon la revendication 14 comprenant en outre des moyens capables d'identifier des variations régionales ou intrahémisphériques dans les ondes cérébrales en réponse à l'application d'une stimulation électrique sur deux subdivisions ou plus des noyaux intralaminaires du patient.
- 50
16. Appareil améliorant les fonctions cognitives selon la revendication 7 dans lequel l'électrode est une électrode multipolaire implantable comprenant un générateur d'impulsion implantable qui est un dispositif commandé par radiofréquence pouvant être actionné par un transmetteur externe.
- 55
17. Appareil améliorant les fonctions cognitives selon la revendication 7 dans lequel les contacts de l'électrode multipolaire implantable permettent un ajustement de la fréquence, de l'amplitude et de la largeur d'impulsion.
18. Appareil améliorant les fonctions cognitives selon la revendication 17 dans lequel les contacts de l'électrode multipolaire implantable permettent un ajustement de la fréquence dans la gamme comprise entre 2 et 200 Hz, un ajustement de l'amplitude dans la gamme comprise entre 0,1 et 10 Volts et un ajustement de la largeur d'impulsion dans la gamme comprise entre 50 et 500 microsecondes.
19. Appareil améliorant les fonctions cognitives selon la revendication 7 dans lequel l'électrode multipolaire implantable est une électrode Medtronic 3387.
20. Appareil améliorant les fonctions cognitives selon l'une quelconque des revendications 4 à 19 dans lequel l'électrode est capable d'administrer des agents pharmacologiques aux structures sous-corticales du patient.
21. Appareil améliorant les fonctions cognitives selon la revendication 20 dans lequel l'électrode comporte des micro-cannules adaptées pour administrer des agents pharmacologiques aux structures sous-corticales du patient.

## EP 1 191 972 B1

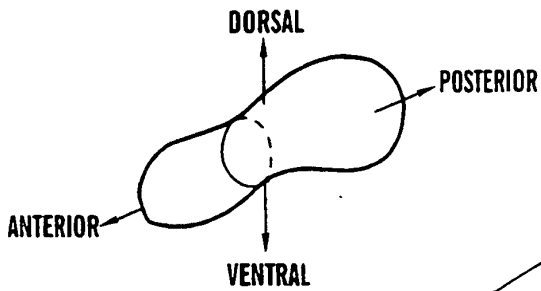
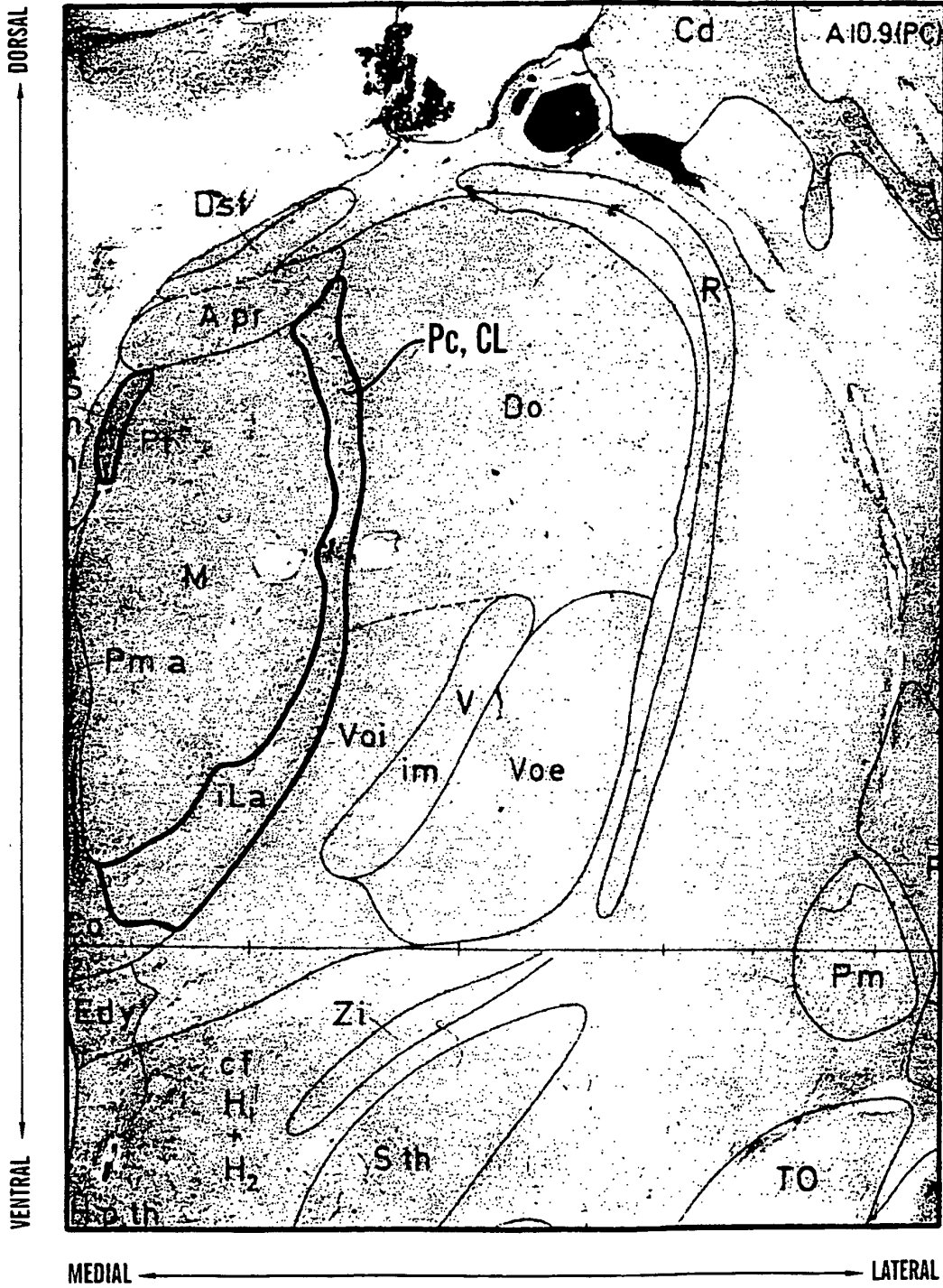
22. Appareil améliorant les fonctions cognitives selon la revendication 20 ou 21 comprenant en outre un agent pharmacologique.
- 5 23. Appareil améliorant les fonctions cognitives selon la revendication 22 dans lequel l'agent pharmacologique est un transmetteur excitateur ou un transmetteur inhibiteur qui est capable d'influencer les fonctions des noyaux intralaminaires.
- 10 24. Appareil améliorant les fonctions cognitives selon la revendication 22 dans lequel l'agent pharmacologique est choisi parmi l'acétylcholine, la noradrénaline, la sérotonine, l'acide gamma-aminobutyrique ou leurs analogues.
- 15 25. Appareil améliorant les fonctions cognitives selon la revendication 22 dans lequel l'agent pharmacologique est un transmetteur d'acide aminé qui est capable d'influencer les fonctions des noyaux intralaminaires.
- 20 26. Appareil améliorant les fonctions cognitives selon la revendication 25 dans lequel l'agent pharmacologique est l'adénosine ou le glutamate.
- 25 27. Appareil améliorant les fonctions cognitives selon l'une quelconque des revendications précédentes comprenant en outre des moyens de stimulation non électrique du patient.
- 30 28. Appareil améliorant les fonctions cognitives selon la revendication 27 dans lequel les moyens de stimulation non électrique du patient sont des moyens capables de stimulation auditive du patient.
- 35 29. Appareil améliorant les fonctions cognitives selon l'une quelconque des revendications précédentes dans lequel les moyens pour détecter les saccades oculaires du patient générées de façon interne sont une caméra.
- 40 30. Appareil améliorant les fonctions cognitives selon l'une quelconque des revendications précédentes dans lequel les moyens pour détecter les saccades oculaires sont choisis parmi :
- 45 (i) un disque dur capable de distinguer l'activité d'électro-oculogrammes ou de la détecter par réflexion infrarouge depuis la pupille ou les cellules de Purkinje ; ou
- 50 (ii) des électrodes adaptées pour être implantées et qui, une fois implantées, sont capable de détecter des électro-oculogrammes, des électromyogrammes, des potentiels de pré-saccades dans l'électroencéphalogramme ou des combinaisons de ceux-ci.
- 55 31. Appareil améliorant les fonctions cognitives selon l'une quelconque des revendications 13 à 15 visant à améliorer la coordination des fonctions entre les zones corticales chez le patient.



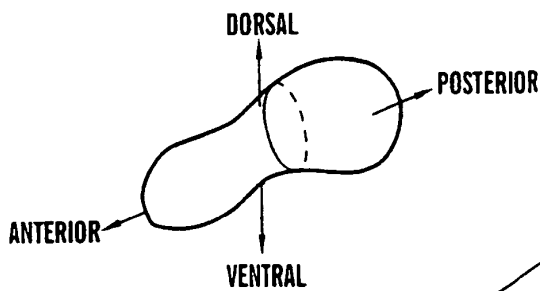
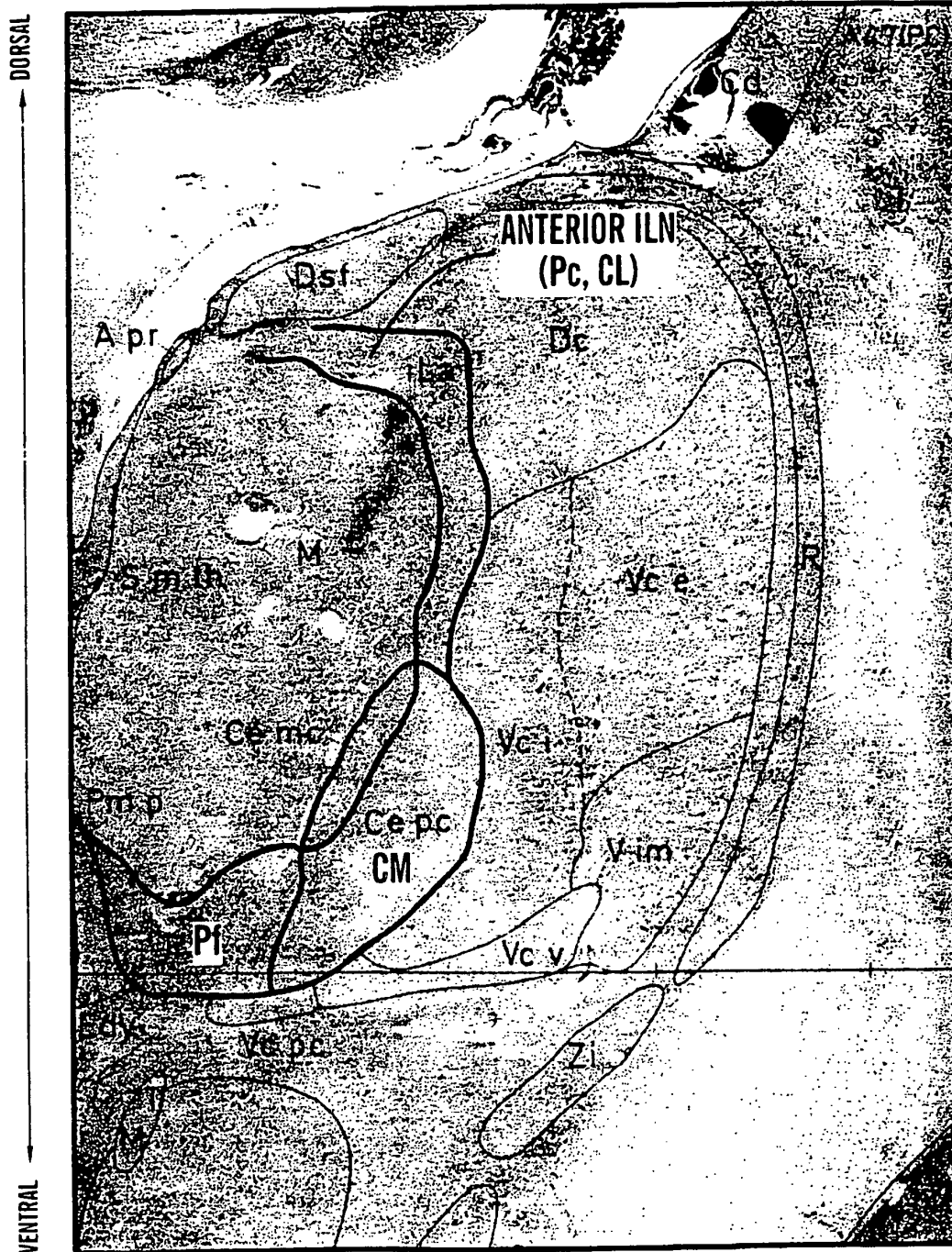
**FIG. 1**



**FIG. 2A**

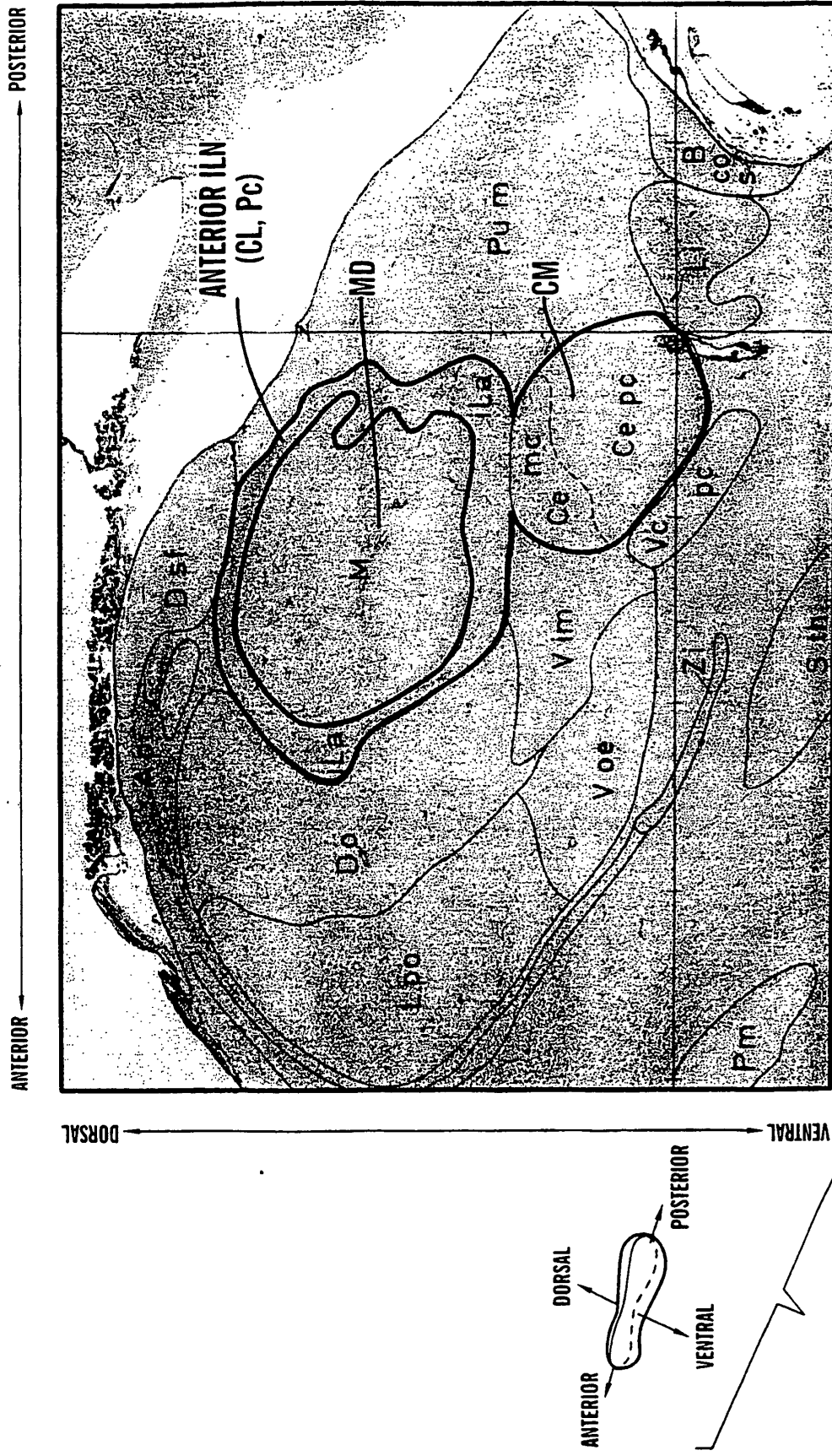


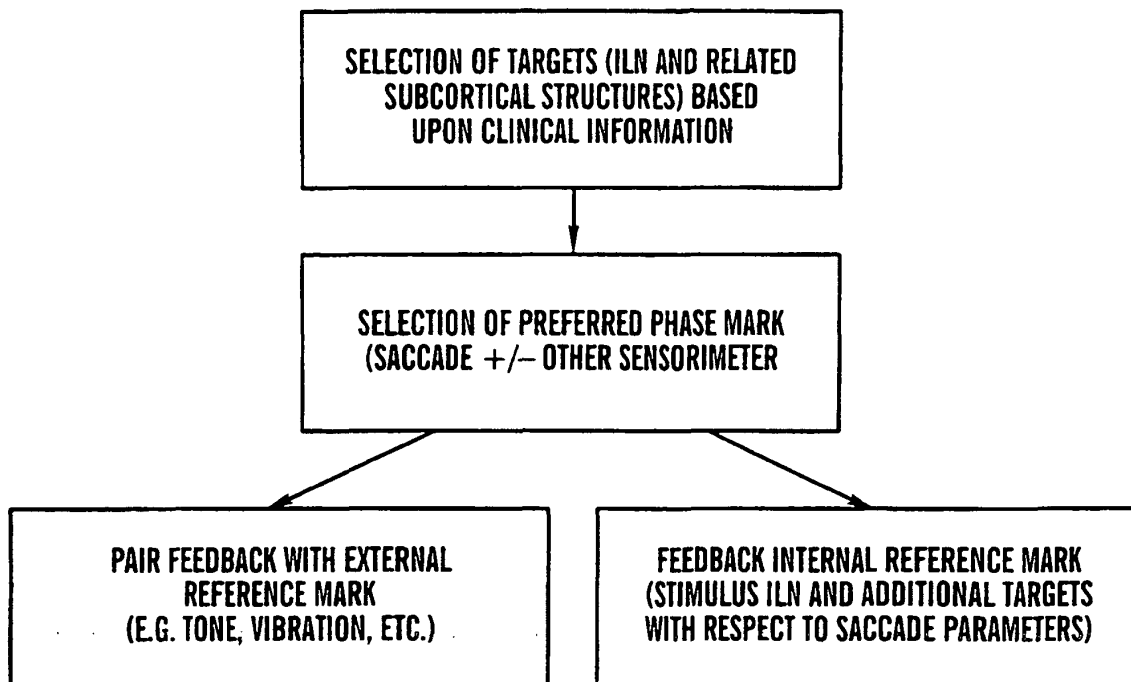
**FIG. 2B**



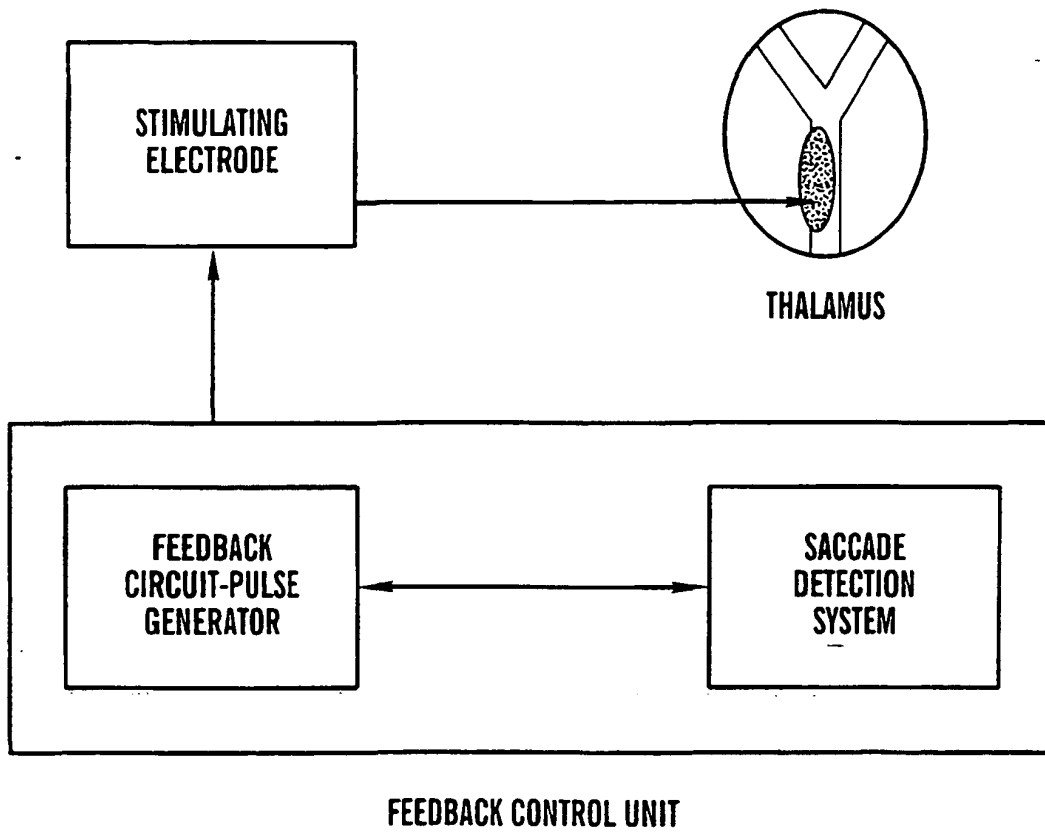
**FIG. 2C**



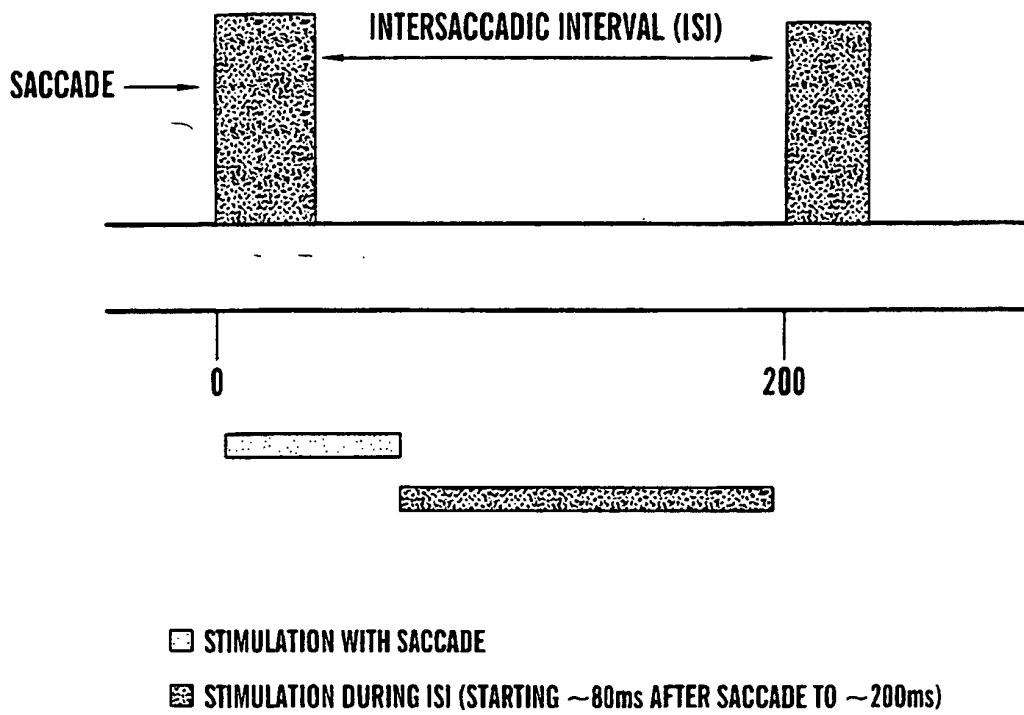




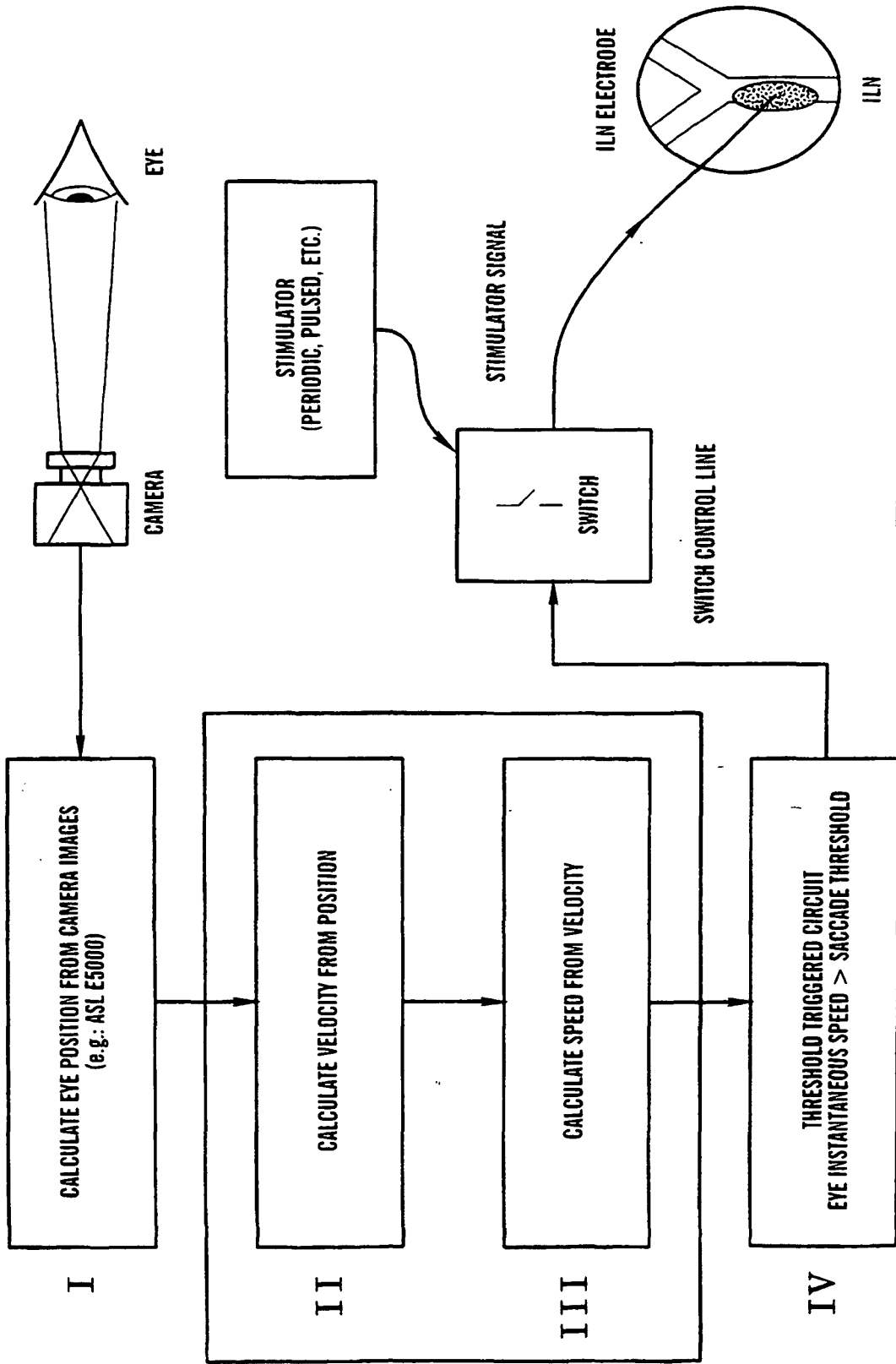
**FIG. 3**



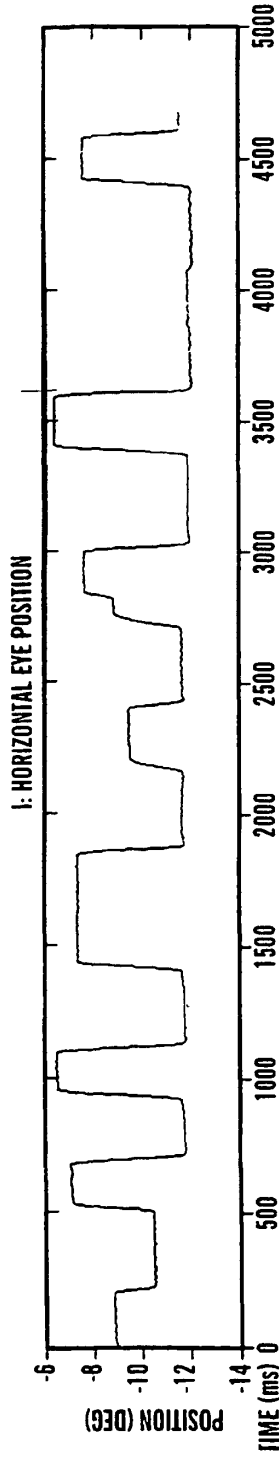
**FIG. 4**



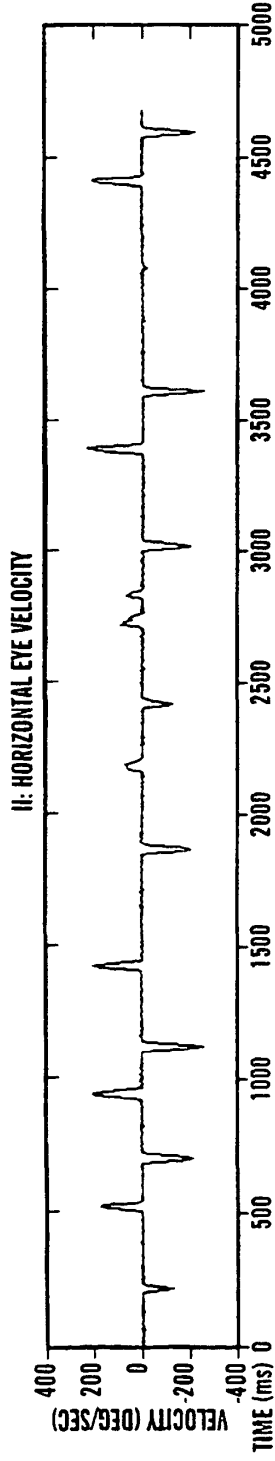
**FIG. 5**



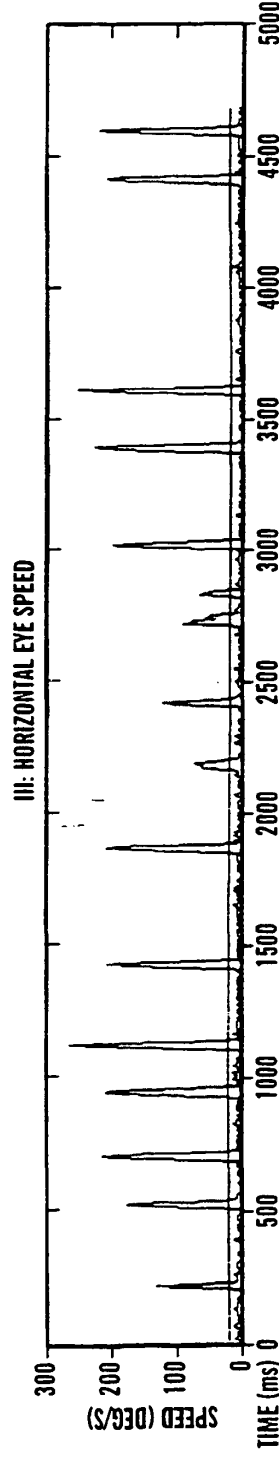
**FIG. 6A**



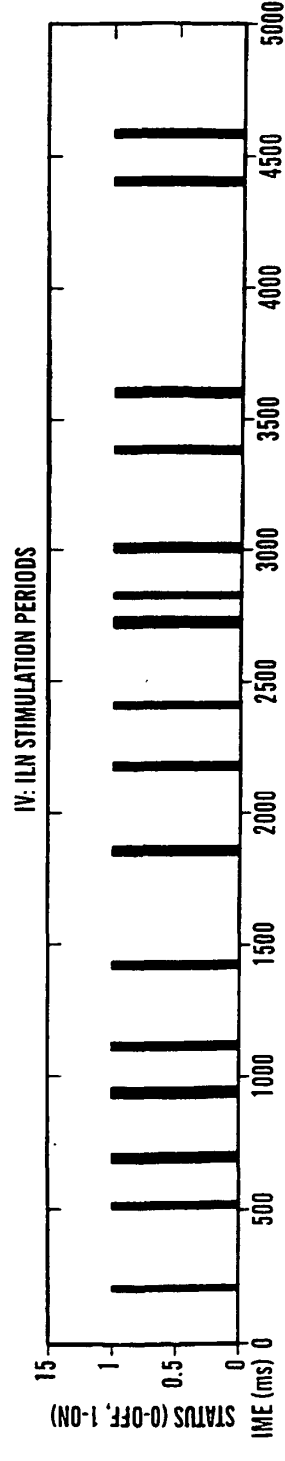
**FIG. 6B**



**FIG. 6C**



**FIG. 6D**



**FIG. 6E**

专利名称(译)	深部脑刺激的反馈机制		
公开(公告)号	<a href="#">EP1191972B1</a>	公开(公告)日	2005-08-31
申请号	EP2000939701	申请日	2000-06-09
[标]申请(专利权)人(译)	康乃尔研究基金会有限公司		
申请(专利权)人(译)	康奈尔研究基金会, INC.		
当前申请(专利权)人(译)	康奈尔研究基金会, INC.		
[标]发明人	SCHIFF NICHOLAS D PURPURA KEITH KALIK STEVEN		
发明人	SCHIFF, NICHOLAS D. PURPURA, KEITH KALIK, STEVEN		
IPC分类号	A61B5/00 A61B5/11 A61B5/113 A61N1/34 A61N1/36		
CPC分类号	A61B5/11 A61B5/113 A61B5/4052 A61B5/486 A61N1/36071 A61N1/36082		
代理机构(译)	MILES, JOHN STEPHEN		
优先权	09/330935 1999-06-11 US		
其他公开文献	EP1191972A1		
外部链接	<a href="#">Espacenet</a>		

摘要(译)

公开了一种用于改善认知功能或改善患者皮质区域的功能协调的方法。该方法包括将电刺激应用于患者皮质下结构的至少一部分,包括产生和控制广义的efference复制信号。然后检测患者的内部产生的运动,并且响应于这种内部产生的运动,控制电刺激的施加。

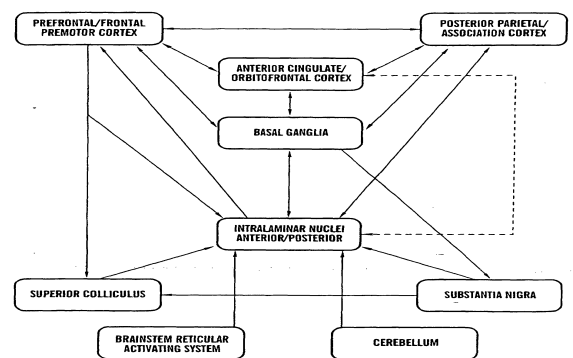


FIG. 1