

(19)



(11)

EP 3 150 116 B1

(12)

EUROPEAN PATENT SPECIFICATION

(45) Date of publication and mention of the grant of the patent:
05.06.2019 Bulletin 2019/23

(51) Int Cl.:
A61B 18/00 ^(2006.01) **A61B 5/00** ^(2006.01)
A61M 25/09 ^(2006.01) **A61B 5/0245** ^(2006.01)
A61B 5/06 ^(2006.01) **A61M 25/00** ^(2006.01)
A61B 34/20 ^(2016.01)

(21) Application number: **16190819.9**

(22) Date of filing: **17.04.2013**

(54) MEDICAL DEVICE GUIDEWIRE WITH HELICAL CUTOUT AND COATING

FÜHRUNGSDRAHT FÜR EINE MEDIZINISCHE VORRICHTUNG MIT SPIRALFÖRMIGER AUSSPARUNG UND BESCHICHTUNG

FIL GUIDE DE DISPOSITIF MÉDICAL COMPRENANT UNE DÉCOUPE HÉLICOÏDALE ET UN REVÊTEMENT

(84) Designated Contracting States:
AL AT BE BG CH CY CZ DE DK EE ES FI FR GB GR HR HU IE IS IT LI LT LU LV MC MK MT NL NO PL PT RO RS SE SI SK SM TR

(72) Inventors:
 • **VANNEY, Guy, P.**
 Blaine, MN 55434 (US)
 • **GUSTAFSSON, Par**
 75308 Uppsala (SE)

(30) Priority: **07.05.2012 US 201213465866**

(74) Representative: **Kramer Barske Schmidtchen**
Patentanwälte PartG mbB
European Patent Attorneys
Landsberger Strasse 300
80687 München (DE)

(43) Date of publication of application:
05.04.2017 Bulletin 2017/14

(62) Document number(s) of the earlier application(s) in accordance with Art. 76 EPC:
13720187.7 / 2 809 223

(56) References cited:
EP-A1- 0 419 277 **EP-A2- 0 367 472**
EP-A2- 0 925 803 **WO-A1-99/13532**
US-A1- 2003 088 193 **US-A1- 2008 132 806**

(73) Proprietor: **St. Jude Medical Atrial Fibrillation**
Division Inc.
St. Paul, Minnesota 55117-9913 (US)

EP 3 150 116 B1

Note: Within nine months of the publication of the mention of the grant of the European patent in the European Patent Bulletin, any person may give notice to the European Patent Office of opposition to that patent, in accordance with the Implementing Regulations. Notice of opposition shall not be deemed to have been filed until the opposition fee has been paid. (Art. 99(1) European Patent Convention).

Description

BACKGROUND OF THE INVENTION

a. Field of the Invention

[0001] The instant disclosure relates generally to a medical device guidewire, and more specifically to a medical device guidewire with a position sensor.

b. Background Art

[0002] Various diagnostic and therapeutic procedures in or on the body of a patient, such as in the circulatory system, the gastrointestinal tract, the brain vessels, the bronchial tree or the like may be performed or facilitated by inserting a catheter into a body lumen and thereafter navigating the diagnostic or therapeutic catheter to the target anatomical site. To facilitate navigation of the catheter, a guidewire is often used. The guidewire typically has a reduced diameter relative to the catheter; the reduced diameter aids a physician in inserting and navigating the guidewire to the anatomical site. The catheter is then passed over the guidewire and guided to the target site. Guidewires are known from US2008/132806 A1, EP 0 367 472 A1, WO 99/13532 A1, EP 0 925 803 A2 and EP 0 419 277 A1.

[0003] One method for maneuvering a guidewire involves the use of fluoroscopy to track the position of a guidewire, particularly its distal tip, during navigation. Another method of maneuvering a guidewire to an operational site is to place one or more position sensors on the guidewire, track the sensors with a navigation system, and display a real-time or rendered image of the guidewire for the clinician manipulating the guidewire to view. One such system for maneuvering a guidewire is detailed in United States application no. 12/357,971 filed 22 January 2009 (published as United States patent application publication no. 2009/0192412 A1 on 30 July 2009).

[0004] Repeated contact between the tip of the guidewire and anatomical features of the patient during navigation is inevitable. Such contact can place unwanted stress on the structure of the guidewire and potentially damage the guidewire. To reduce instances of contact while maneuvering a guidewire to a target anatomical region, it is desirable for a clinician to be able to "see" the extreme distal tip of the guidewire. Accordingly, in embodiments where the guidewire is tracked by a navigation and positioning system, it is desirable to place a position sensor as close to the distal tip of the guidewire as possible. Moreover, regardless of the location of the position sensors on the guidewire, it is also desirable to protect the position sensor(s) and associated wiring from bending-induced stress as well as from exposure to body fluids to ensure reliable electrical function of the sensors. In addition, in the situation where the guidewire is used in delivering a cardiac pacing lead, it would be desirable

that the guidewire be configured to be mechanically and electrically compatible with the lead.

[0005] The foregoing discussion is intended only to illustrate the present field and should not be taken as a disavowal of claim scope.

BRIEF SUMMARY OF THE INVENTION

[0006] The invention is defined by the appended claims. Subject matter referred as embodiments and/or inventions which are not claimed are not part of the invention. In an embodiment, a guidewire comprises an elongate body, a proximal connector assembly, a corewire, a sensor assembly, an electrically insulating structure and a D-shaped pin. The elongate body comprises a proximal and distal end portions. The body further has an annular wall that defines an interior lumen. The proximal connector assembly may be coupled to the proximal end portion of the body. The proximal connector assembly may be configured for connection to a medical positioning system. The corewire may have proximal and distal end portions. The corewire may extend through the lumen of the elongate body. The sensor assembly may be located on the distal end portion of the corewire and distal of the elongate body. The sensor assembly may be electrically connected by a pair of electrical conductors to the proximal connector assembly. The electrically insulating structure surrounds the corewire and insulates the corewire from the pair of electrical conductors. The D-shaped pin includes proximal and distal end portions, wherein the distal end portion of the D-shaped pin is connected to the proximal end portion of the corewire and the proximal end portion of the D-shaped pin is connected to a proximal end of the proximal connector assembly. The D-shaped pin is configured to provide a clearance for the electrical conductors to pass through the elongate connector assembly.

[0007] The foregoing and other aspects, features, details, utilities, and advantages of the present invention will be apparent from reading the following description and claims, and from reviewing the accompanying drawings.

BRIEF DESCRIPTION OF THE DRAWINGS

[0008]

Figure 1 is a schematic and block diagram view of a system incorporating an embodiment of a guidewire. Figure 2 is a diagrammatic view of an exemplary catheter-lab environment in which the system of Figure 1, particularly including a medical positioning system (MPS) enabled guidewire, may be used. Figure 3 is a diagrammatic view of an embodiment of a guidewire. Figure 4 is a cross-sectional side view of a portion of the guidewire of Figure 3. Figure 5 is a cross-sectional side view of a portion

of the guidewire of Figure 3.

Figure 6 is a cross-sectional side view of a portion of the guidewire of Figure 3.

Figure 7 is a diagrammatic side view of a portion of a body of the guidewire of Figure 3, illustrating a helical cutout on the body.

Figure 8 is a cross-sectional side view of a portion of the guidewire of Figure 3.

Figure 9 is a circumferential cross-sectional view of the guidewire of Figure 8, taking substantially along line 9-9.

Figure 10 is a cross-sectional side view of a portion of the guidewire of Figure 3.

Figure 11 is a circumferential cross-sectional view of the guidewire of Figure 4, taking substantially along line 11-11.

Figure 12 is a circumferential cross-sectional view of the guidewire of Figure 4, taking substantially along line 12-12.

Figure 13 is a schematic and block diagram view of one exemplary embodiment of a medical positioning system (MPS) as shown in block form in Figure 1.

DETAILED DESCRIPTION OF THE INVENTION

[0009] Various embodiments are described herein to various guidewires. Numerous specific details are set forth to provide a thorough understanding of the overall structure, function, manufacture, and use of the embodiments as described in the specification and illustrated in the accompanying drawings. It will be understood by those skilled in the art, however, that the embodiments may be practiced without such specific details. In other instances, well-known operations, components, and elements have not been described in detail so as not to obscure the embodiments described in the specification. Those of ordinary skill in the art will understand that the embodiments described and illustrated herein are non-limiting examples, and thus it can be appreciated that the specific structural and functional details disclosed herein may be representative and do not necessarily limit the scope of the embodiments, the scope of which is defined solely by the appended claims.

[0010] Reference throughout the specification to "various embodiments," "some embodiments," "one embodiment," or "an embodiment," or the like, means that a particular feature, structure, or characteristic described in connection with the embodiment is included in at least one embodiment. Thus, appearances of the phrases "in various embodiments," "in some embodiments," "in one embodiment," or "in an embodiment," or the like, in places throughout the specification are not necessarily all referring to the same embodiment. Furthermore, the particular features, structures, or characteristics may be combined in any suitable manner in one or more embodiments. Thus, the particular features, structures, or characteristics illustrated or described in connection with one embodiment may be combined, in whole or in part, with the

features, structures, or characteristics of one or more other embodiments without limitation given that such combination is not illogical or non-functional.

[0011] It will be appreciated that the terms "proximal" and "distal" may be used throughout the specification with reference to a clinician manipulating one end of a medical device or instrument used to treat a patient. The term "proximal" refers to the portion of the device closest to the clinician and the term "distal" refers to the portion located furthest from the clinician. It will be further appreciated that for conciseness and clarity, spatial terms such as "vertical," "horizontal," "up," and "down" may be used herein with respect to the illustrated embodiments. However, medical devices may be used in many orientations and positions, and these terms are not intended to be limiting or absolute.

[0012] Referring now to the drawings wherein like reference numerals are used to identify identical or similar components in the various views, Figure 1 is a block diagram view of a system 10 in which a position sensing guidewire may be used. System 10 as depicted includes a main electronic control unit 12 (e.g., including one or more electronic processors) having various input/output mechanisms 14, a display 16, an optional image database 18, a localization system such as a medical positioning system (MPS) 20, an electrocardiogram (ECG) monitor 22, one or more MPS location sensors respectively designated 24₁ and 24₂, and an MPS-enabled guidewire 26 which itself includes one and optionally more MPS location sensors, shown in exemplary fashion as having one such sensor 24₁.

[0013] Input/output mechanisms 14 may comprise conventional apparatus for interfacing with a computer-based control unit, for example, a keyboard, a mouse, a tablet, a foot pedal, a switch or the like. Display 16 may also comprise conventional apparatus.

[0014] Embodiments consistent with the instant disclosure may find use in navigation applications that use imaging of a region of interest. Therefore system 10 may optionally include image database 18. Image database 18 may be configured to store image information relating to the patient's body, for example, a region of interest surrounding a destination site for medical device 26 and/or multiple regions of interest along a navigation path contemplated to be traversed by device 26 to reach the destination site. The image data in database 18 may comprise known image types including (1) one or more two-dimensional still images acquired at respective, individual times in the past; (2) a plurality of related two-dimensional images obtained in real-time from an image acquisition device (e.g., fluoroscopic images from an x-ray imaging apparatus, such as that shown in exemplary fashion in Figure 2) wherein the image database acts as a buffer (live fluoroscopy); and/or (3) a sequence of related two-dimensional images defining a cine-loop (CL) wherein each image in the sequence has at least an ECG timing parameter associated therewith adequate to allow playback of the sequence in accordance with acquired

real-time ECG signals obtained from ECG monitor 22. It should be understood that the foregoing are examples only and not limiting in nature. For example, the image database 18 may also include three-dimensional image data as well. It should be further understood that the images may be acquired through any imaging modality, now known or hereafter developed, for example X-ray fluoroscopy, ultra-sound, computerized tomography, nuclear magnetic resonance or the like.

[0015] MPS 20 is configured to serve as the localization system and therefore to determine positioning (localization) data with respect to one or more of MPS location sensors 24_i (where $i = 1$ to n) and output a respective location reading. The location readings may each include at least one or both of a position and an orientation (P&O) relative to a reference coordinate system, which may be the coordinate system of MPS 20. For example, the P&O may be expressed as a position (*i.e.*, a coordinate in three axes X, Y and Z) and orientation (*i.e.*, an azimuth and elevation) of a magnetic field sensor in a magnetic field relative to a magnetic field generator(s) or transmitter(s).

[0016] MPS 20 determines respective locations (*i.e.*, P&O) in the reference coordinate system based on capturing and processing signals received from the magnetic field sensors 24_i while such sensors are disposed in a controlled low-strength AC magnetic field (see Figure 2). From an electromagnetic perspective, these sensors develop a voltage that is induced on the sensing coil residing in a changing magnetic field, as contemplated here. Sensors 24_i are thus configured to detect one or more characteristics of the magnetic field(s) in which they are disposed and generate an indicative signal, which is further processed by MPS 20 to obtain a respective P&O thereof. Exemplary design features and manufacturing processes and methods for sensors 24_i and medical devices incorporating such sensors are known in the art.

[0017] MPS sensor 24_1 , and optionally additional MPS sensors in further embodiments, may be associated with MPS-enabled medical device 26. Another MPS sensor, namely, patient reference sensor (PRS) 24_2 (if provided in system 10) is configured to provide a positional reference of the patient's body so as to allow motion compensation for gross patient body movements and/or respiration-induced movements. PRS 24_2 may be attached to the patient's manubrium sternum, a stable place on the chest, or another location that is relatively positionally stable. Like MPS location sensor 24_1 , PRS 24_2 is configured to detect one or more characteristics of the magnetic field in which it is disposed wherein MPS 20 provides a location reading (*e.g.*, a P&O reading) indicative of the PRS's position and orientation in the reference coordinate system.

[0018] The electro-cardiogram (ECG) monitor 22 is configured to continuously detect an electrical timing signal of the heart organ ("organ timing signal") through the use of a plurality of ECG electrodes (not shown), which may be externally-affixed to the outside of a patient's

body. The timing signal generally corresponds to the particular phase of the cardiac cycle, among other things. Generally, the ECG signal(s) may be used by the control unit 12 for ECG synchronized play-back of a previously captured sequence of images (cine loop) stored in database 18. ECG monitor 22 and ECG-electrodes may both comprise conventional components.

[0019] Figure 2 is a diagrammatic view of system 10 as incorporated into a larger system, namely, a catheter lab. More specifically, the system 10 is shown as being incorporated into an fluoroscopic imaging system 28, which may include commercially available fluoroscopic imaging components. It should be understood that while embodiments may be used in the catheter-lab environment to be described below, this is exemplary only and not limiting in nature. MPS 20 includes a magnetic transmitter assembly (MTA) 30 and a magnetic processing core 32 for determining location (P&O) readings. MTA 30 is configured to generate the magnetic field(s) in and around the patient's chest cavity, in a predefined three-dimensional space identified as a motion box 34. MPS sensors 24_i as described above are configured to sense one or more characteristics of the magnetic field(s) and when the sensors are in motion box 34, each generate a respective signal that is provided to magnetic processing core 32. Processing core 32 is responsive to these detected signals and is configured to calculate respective P&O readings for each MPS sensor 24_i in motion box 34. Thus, MPS 20 enables real-time tracking of each sensor 24_i in three-dimensional space.

[0020] The positional relationship between the image coordinate system and the MPS reference coordinate system may be calculated based on a known optical-magnetic calibration of the system (*e.g.*, established during setup), since the positioning system and imaging system may be considered fixed relative to each other in such an embodiment. However, for other embodiments using other imaging modalities, including embodiments where the image data is acquired at an earlier time and then imported from an external source (*e.g.*, imaging data stored in database 18), a registration step registering the MPS coordinate system and the image coordinate system may need to be performed so that MPS location readings can be properly coordinated with any particular image being used. One exemplary embodiment of an MPS 20 will be described in greater detail below in connection with Figure 13.

[0021] Figure 3 is a diagrammatic view, with portions broken away, of a guidewire 36 that may be used as the medical device 26 in system 10 (Fig. 1). Figure 3 shows guidewire 36 in a completed state of assembly and several components thereof will be identified before proceeding to the remainder of the detailed description. Guidewire 36 is generally elongate and extends along a central longitudinal axis designated "A" between a guidewire distal end 38 and a guidewire proximal end 40.

[0022] The guidewire 36 includes a sensor assembly 54 (*i.e.*, best shown in Fig. 4) having an output signal

useful for position detection. As shown, the sensor assembly 54 is very close the extreme distal end 38, and hence provides very accurate indication of the location of the distal tip, for example, for intra-body navigation.

[0023] The guidewire 36 further includes an elastomeric coating 60 (*i.e.*, best shown in Figure 4) whose uniform outside diameter (OD), smooth outer surface is particularly useful for delivering cardiac pacing leads, which fit over coating 60 without entanglement.

[0024] The guidewire 36 further includes a body 90 (*e.g.*, tube, best shown in Fig. 7) having a helical cut out 92 (*i.e.*, best shown in Fig. 7) whose pitch decreases towards distal end 38, thus increasing the flexibility of body 90 towards distal end 38. The increase in flexibility improves navigability.

[0025] The proximal end of tube 90 is ground (*i.e.*, reduced outside diameter) so as to permit mechanical coupling to a proximal connector assembly 98. The proximal connector assembly 90 also provides electrical connectivity between the guidewire (*i.e.*, in particular the sensor assembly 54) and external equipment, such as MPS 20.

[0026] The guidewire 36 further includes a central corewire 52 (*i.e.*, best shown in Figs. 4-6 and 8) extending generally from proximal connector assembly 98 to the extreme distal plug of guidewire 36. The corewire 52 provides improved mechanical properties of the guidewire 36. For descriptive purposes only, guidewire 36 may have a first portion 42, a second portion 44, a third portion 46, a fourth portion 48, and a fifth portion 50. Each portion will be described in further detail below.

[0027] Figure 4 is a diagrammatic, cross-sectional side view showing the distal end of guidewire 36 in greater detail (*i.e.*, first portion 42), with portions broken away. Figures 11 and 12 are cross-sectional views taken along lines 11-11 and 12-12, respectively, in Figure 4. Guidewire 36 includes central corewire 52, sensor assembly 54, a shroud 56, a plug 58, and a coating 60.

[0028] Corewire 52 is configured to distribute bending stresses, tensile loads, and compressive loads over its length, reducing stress on the other components of guidewire 36, such as the wiring that electrically connects sensor assembly 54 to the proximal connector assembly 98. In other words, loads (*e.g.*, due to contact with tissue) imposed on shroud 56 are transferred via coating 60 to plug 58 to corewire 52, and similarly loads directly imposed on coating 60 to plug 58 are likewise resolved through corewire 52. Corewire 52 contributes to the overall mechanical properties of the guidewire 36.

[0029] Corewire 52 is located substantially at the radial center of guidewire 36. In other words, a central longitudinal axis 66 of corewire 52 is substantially the same as or coincident with central axis "A" of guidewire 36. Corewire 52 has a distal end portion which, in the illustrated embodiment, generally coincides with guidewire distal end 38, and is at least as co-extensive as the axial extent of shroud 56. An extreme distal end 62 of corewire 52 may be flush with or may extend distally a distance d_1 past the distal end of the sensor assembly 54, being

situated substantially in the central region of plug 58. In distal end portion, corewire 52 has a circular cross-section of constant diameter (best seen in Figures 11-12). Corewire 52 further includes a proximal end portion 64, as seen in Figure 8.

[0030] In an embodiment, corewire 52 may be made of metal, such as stainless steel, titanium, or nickel titanium alloys (*i.e.*, NITINOL), or other biocompatible material. In an embodiment, corewire 52 may be a single continuous wire extending substantially the entire axial length of guidewire 36 (*i.e.*, from proximal connector 98 to plug 58), which may provide the benefit of distributing bending stresses over the entire length of guidewire 36. In another embodiment (not shown), corewire 52 may be a multi-piece construction, such as the construction described in United States application no. 12/359,010 filed 23 January 2009 (published as United States patent application publication no. 2009/0192413 A1 on 30 July 2009).

[0031] The illustrated embodiment of corewire 52 is intended to be exemplary only and not limiting. Many variations could be made to corewire 52 and still fall within the scope of the present disclosure. For example, corewire 52 may comprise a material other than metal and may have a non-circular cross-section. Additionally, corewire 52 may be solid, hollow, or have some other interior construction.

[0032] Sensor assembly 54 is configured to detect one or more characteristics of a magnetic field in which it is disposed and produce an output electrical indicative thereof. The output signal, as described above (see description relating to sensor 24) can be processed by MPS 20 to produce a location of the sensor assembly 54. The location can include at least one or both of the position and orientation of the sensor assembly 54 in a reference coordinate system. In an embodiment, sensor assembly 54 may be substantially similar or the same as the sensor assembly described in U.S. Application No. 12/980,848 filed 29 December 2010.

[0033] Sensor assembly 54 is located radially-outwardly from corewire 52 and may comprise multiple elements, or may be unitary. In the illustrated embodiment, sensor assembly 54 comprises a hollow cylindrical sensor core 68 with a wire 70 wound on sensor core 68 to form a sensor coil with two free ends thereof forming a pair of sensor leads 72_1 , 72_2 which are available at a proximal end of sensor assembly 54. Sensor core 68 may be a tube comprising magnetically permeable material, with the tube having a central lumen, where corewire 52 passes through the central lumen.

[0034] A clearance 73 may exist between an inner diameter of sensor core 68 and outer diameter of corewire 52, as seen in Figure 11. Clearance 73 may be filled with an insulating material, such as epoxy, which secures sensor core 68 to corewire 52 and insulates sensor core 68 from corewire 52. Sensor core 68 may comprise magnetically-permeable material which increases the overall sensitivity of the sensor core/sensor coil combination 68,

70 that forms positioning sensor assembly 54 (as compared to the same coil configuration without a magnetically-permeable core). In an embodiment, sensor core 68 may be made of a metal alloy of magnetically-permeable material, such as an alloy of nickel and iron.

[0035] In an embodiment, when sensor core 68 is secured (e.g., via epoxy) to the distal end portion of corewire 52, corewire 52 may additionally act as a safety wire. In the event that any portion of guidewire 36 is structurally compromised (e.g., body 90 is fractured), the bond between corewire 52 and sensor assembly 54 maintains the structural integrity with the extreme distal end portion 62 of guidewire 36. The bond between corewire 52 and sensor assembly 54 acts as a safety feature allowing for extraction of the extreme distal end of guidewire 36 from the patient. In an embodiment, corewire 52 may additionally be secured to the proximal end of guidewire 36, such as bonding proximal end portion 64 of corewire 52 to proximal connector assembly 98 using an adhesive 108 (e.g. epoxy), and the safety feature of corewire 52 may be maintained from distal end to proximal end of guidewire 36.

[0036] As described above, a function of sensor assembly 54, in the context of a magnetic field based positioning system, is to detect one or more characteristics of the magnetic field(s) in which sensor assembly 54 is placed. In this regard, one of ordinary skill in the art will appreciate there are many variations and configurations of sensor assembly 54. For example and without limitation, while sensor assembly 54 is shown in the distal end portion of guidewire 36, the position of sensor assembly 54 and/or position of a plurality of sensor assemblies 54 may be located throughout guidewire 36 and such variations and configurations remain within the scope of the present disclosure.

[0037] With continued reference to Figure 4, guidewire 36 may further comprise a wire cable 74, an insulator tube 76, and an alignment tube 78. Wire cable 74 may comprise a first wire 74₁ and a second wire 74₂. First wire 74₁ and second wire 74₂ may be twisted together, forming a twisted pair along a substantial length of wire cable 74. For example, for the substantial portion of the axial length of guidewire 36, starting from proximal connector assembly 98 and extending distally towards sensor assembly 54, the wires 74₁, 74₂, remain twisted, as shown in Figure 5. The twisting of the wires improves noise reduction, as known. However, as the wire cable 74 approaches sensor assembly 54, the two wires 74₁, 74₂ are separated (i.e., untwisted) in order to allow respective electrical connection to the two free ends of sensor coil 70.

[0038] In this regard, sensor leads 72₁, 72₂ are conductively connected to wire cable 74 at connection nodes 80₁, 80₂. As shown, sensor lead 72₁ may be conductively connected (i.e., electrically connected) to first wire 74₁ at connection node 80₁, and sensor lead 72₂ may be conductively connected to second wire 74₂ at connection node 80₂.

[0039] Insulator tube 76 is configured to electrically isolate corewire 52 from the other electrically active components at the distal end of guidewire 36. In this regard, sensor leads 72₁, 72₂, connection nodes 80₁, 80₂, and a portion of wire cable 74 are electrically insulated from corewire 52 by insulator tube 76. In an embodiment, insulator tube 76 may be a polymer tube, such as, but not limited to, polyimide, that is slipped onto corewire 52. Alternatively, insulator tube 76 may comprise a heat-activated "shrink" tube comprising electrically insulating material. In a further embodiment, insulator tube 76 may be a layer of polymer that is sprayed onto or otherwise applied to corewire 52, or some other electrically insulating structure on corewire 52.

[0040] Alignment tube 78 is configured to provide mechanical protection for the sensor assembly/twisted pair connections (i.e., connections 80₁, 80₂), particularly from externally-imposed forces encountered during use (e.g., contacting body/tissue structures). One failure mode for a guidewire of the type including such electrical connections is the disconnection or failure of the electrical connection at one or both of 80₁, 80₂. The alignment tube 78 helps mitigate this problem. In addition, alignment tube 78 is configured to provide a uniform outside diameter structure onto which shroud 56 can conform. Alignment tube 78 thus also provides a manufacturing function.

[0041] The alignment tube 78 is located proximal of the sensor assembly 54 and distal of a body coil 88. Alignment tube 78 may have an outside diameter that is approximately the same as the outside diameter of the sensor assembly 54, and have an inside diameter that is large enough to enclose at least the connections 80₁, 80₂ that the tube 78 is configured to protect. Alignment tube 78 may comprise a polymer tube comprising, for example only, polyimide material or the like.

[0042] Referring to Figure 12, alignment tube 78 includes an interior space, designated space 82 that is large enough to accommodate sensor leads 72₁, 72₂, connection nodes 80₁, 80₂, and a portion of wire cable 74, which are routed therethrough. In an embodiment, space 82 may ultimately be filled with a nonconductive epoxy material 84. Epoxy material 84, when cured, provides mechanical protection for sensor leads 72₁, 72₂, connection nodes 80₁, 80₂, and a portion of wire cable 74. Epoxy material 84 also bonds insulator tube 76, sensor leads 72₁, 72₂, connection nodes 80₁, 80₂, a portion of wire cable 74, sensor core 68, sensor coil 70, a portion of shroud 56, a portion of corewire 52, and body coil 88 together.

[0043] Referring to Figures 4-5 and Figures 11-12, shroud 56 is configured to provide a smooth, substantially continuous cylindrical sub-assembly to which the corewire 52 can be bonded (i.e., provides a potting volume). In addition, shroud 56 may provide some measure of protection to the interior components of the distal assembly from compressive and tensile loads resulting from insertion, removal, and bending of guidewire 36.

The shroud 56 comprises a tube that directly covers the outer circumferential surfaces of sensor assembly 54, alignment tube 78, and a portion of epoxy material 84. A distal end of shroud 56 may be aligned with the distal end of sensor assembly 54 and the distal end of shroud 56 may be adjacent to a proximal end of plug 58. Shroud 56 may be a polymer shrink tube or another electrically insulating structure or material. For example only, shroud 56 may comprise polyethylene terephthalate (PET) material, although shroud 56 may comprise materials other than PET. The illustrated embodiment of shroud 56 is exemplary only, and should not be construed as limiting. Although shroud 56 is shown as a thin-walled tube of substantially constant diameter, shroud 56 may have another shape or cross-section, which may be constant or may vary along its axial length.

[0044] Plug 58 is provided at the extreme distal end of guidewire 36 for structural support and to provide for non-traumatic contact of the extreme distal end of guidewire 36 when introducing and navigating the guidewire through a lumen of a patient. Plug 58 is preferably rounded and may be made of polymer, glue, bonding material, metal, or any other relatively smooth material suitable for this purpose. Plug 58 is shown in a hemispherical shape, but may be in any other non-traumatic form. Plug 58 may be coupled to one or more of corewire 52, sensor assembly 54, and shroud 56 by gluing, bonding, welding, soldering, or another patient-safe coupling method.

[0045] Figures 5-6 and 8 are cross-sectional side views, with portions broken-away, of second portion 42, third portion 44, fourth portion 46 of guidewire 36. Figure 7 is a diagrammatic side view of a body 90 having a helical cutout 92. As seen in Figures 5-8, guidewire 36 may further comprise body coil 88, body 90, and helical cutout 92.

[0046] Body coil 88 is configured to provide bending flexibility as well as, in an embodiment, radiopacity by virtue of material selection. In this regard, body coil 88 may comprise radiopaque material (e.g., metal), such as platinum, to increase fluoroscopic visibility. Body coil 88 may also be made of stainless steel, iridium, or nickel titanium alloys (i.e., NITINOL). In addition to providing flexibility and fluoroscopic visibility, body coil 88 also protects cable wiring 74 that is proximally located with respect to shroud 56. The proximal end of body coil 88 may be soldered to tube 90 while the distal end of body coil 88 may be bonded to sensor assembly 54 by conventional methods (e.g., with an adhesive such as medical grade epoxy, or with another patient-safe (biocompatible) coupling method).

[0047] Body 90, which may comprise a flexible elongate hollow tube that allows the passage of electrical wiring therethrough. Body 90 thus includes an annular wall 94 defining a central lumen 96 configured to provide sufficient space for the electrical wiring as well as the corewire 52, while at the same time having a minimum impact on the torque transfer and structural characteristics of the guidewire 36. As described above, corewire 52 and cable wiring 74 run throughout lumen 96.

[0048] As best shown in Figure 8, the proximal end of body 90 is attached to proximal connector assembly 98. The proximal end of body 90 may be ground down (i.e., reduced outside diameter), for example as a taper or as a step or shoulder, to facilitate attachment to connector assembly 98. As shown in Figure 8, the reduced outside diameter of body 90 corresponds to the inside diameter of the distal end portion of proximal connector body 98, thereby allowing a low-clearance fit or interference fit.

[0049] As best shown in Figure 3, body 90 may have variable outside diameter along various portions of body 90. For example, in an embodiment, the outside diameter of the distal portion of body 90 may be smaller than the outside diameter of the proximal portion of body 90. This difference in outside diameter may be seen by comparison of the two distal-most tube portions in Figure 3 (i.e., the proximal portion of tube 90 has a greater outside diameter than the adjacent distal portion). The reduced outside diameter along the distal portion of body 90 provides radial space for coating 60 without the resultant outside diameter exceeding a preferred maximum outside diameter of guidewire 36.

[0050] In an embodiment, the progressively decreasing outside diameter of body 90 (as taken in the distal direction) may be achieved by reducing the thickness of annular wall 94 by known methods. For example, one known method may involve grinding down or drawing down the outer surface of annular wall 94. Through the foregoing, the inside diameter of body 90 remains the same, but the thickness of annular wall 94 along the distal portion of body 90 is reduced, thereby also reducing the outside diameter thereof. In an embodiment, the reduced thickness of annular wall 94 may extend approximately ten inches from the distal end of body 90 toward the proximal end of body 90. The reduction in thickness of annular wall 94 may be performed in steps, or may be a gradual transition. The reduced thickness of the body may be used to design a preferred amount of flexibility of body 90. In an embodiment, body 90 may be made of metal. When body 90 is metal, it may be connected to an electrical ground and act as electrical interference shielding for wire cable 74 passing through lumen 96 of body 90.

[0051] Body 90 is provided with a helical cutout 92 to configure body 90 with greater or lesser levels of flexible in predefined areas. Helical cutout 92, in an embodiment, involves completely removing wall material from annular wall 94. In an embodiment, helical cutout 92 may extend substantially from the distal end of body 90 for a predetermined axial length, spiraling proximally towards the proximal end of body 90. In one embodiment, the pitch, which may be defined as the axial distance corresponding to one revolution of the helix, is substantially constant. In another embodiment, however, the pitch varies as a function of axial position from the distal end of body 90.

[0052] Referring to Figure 7, body 90 is provided with helical cutout 92 that has a progressively increasing pitch as the helical cutout 92 extends away from the distal end of body 90 toward the proximal end of body 90. For ex-

ample, in a first interval 100₁ (distal-most portion of body 90) no helical cutout 92 is provided on body 90. In second, third, fourth, fifth, sixth and seventh intervals 100₂-100₇, respectively, the pitch along body 90 (axially) either increases or is maintained. An eighth interval 100₈ of body 90 does not incorporate a helical cutout 92. The lower the pitch, the more flexible body 90 will be in that interval. In the illustrated embodiment, body 90 will be most flexible along distal end and gradually become less flexible (e.g., more stiff) as helical cutout 92 moves proximally. In an embodiment, the pitch of helical cutout 92 may transition gradually. In an embodiment, helical cutout 92 may have a width "W" as seen in Figure 6. In an embodiment, width "W" of helical cutout 92 may be substantially constant. In an embodiment, the tube 90 may be hypo tube stock, and where the helical cutout 92 may be formed using laser cutting or other methods known in the art. Although one embodiment of width "W" of helical cutout 92 has been provided, it is appreciated that other widths may be used to control the amount of flexibility as desired, and other widths not provided in detail remain within the scope of the present disclosure.

[0053] Coating 60 creates a smooth, continuous, substantially uniform outside diameter surface which is advantageous in some medical applications, such as delivering pace-maker leads and other implantable device leads. For example, the nature of the outer surface of coating 60 acts as a lubricant of sorts with an inside diameter of such leads, preventing lock up of the inside diameter surface of the leads with the outside diameter surface of sensor assembly 54 and body coil 88. Coating 60 is a radially outermost hyperelastic polymeric layer disposed on distal portion of guidewire 36. Coating 60 may be a relatively soft and flexible material, such as a polyurethane elastomer commercially available under the trade designation PELLETHANE, from The Lubrizol Corporation, Wickliffe, Ohio, USA. In a PELLETHANE material embodiment, the material used for coating 60 may have a hardness of about 55D (durometer). In another embodiment, the material used for coating 60 may have a hardness range of about 35D to 65D. It should be understood, however, that other materials may be used for coating 60, such as a thermoplastic elastomer available under the trade designation SANTOPRENE available from ExxonMobil Chemical Company, Houston, Texas, USA.

[0054] Coating 60 completely circumferentially surrounds plug 58 and extends proximally over body 90 to approximately the point where the taper of body 90 begins. Thus, coating surrounds shroud 56, body coil 88, helical cutout 92 and a portion of body 90. Coating 60 completely covers helical cutout 92, and therefore seals what would otherwise be an opening into body 90 caused by helical cutout 92. Coating 60 advantageously seals the distal end portion of guidewire 36, rendering the distal end portion of guidewire 36 watertight. Coating 60 may be hydrophilic or hydrophobic, and may have an overcoat of hydrophilic coating material. In an embodiment, the

maximum outermost diameter of coating 60 does not exceed a maximum outermost diameter at any point along the entire guidewire 36. In an embodiment, coating 60 may have a thickness such that a maximum outer diameter of the guidewire 36 may be 0,3556 mm to 0,368 mm (0,0140 inches to 0,0145 inches). This may be advantageous in allowing a pacing lead to pass over the entire length of guidewire 36.

[0055] Figures 9-10 are cross-sectional views of an embodiment of fifth portion 50 of guidewire 36. Figure 9 is a circumferential cross-sectional view of proximal connector assembly 98. Figure 10 is a diagrammatic cross-sectional side view of proximal connector assembly 98.

[0056] In an embodiment, proximal connector assembly 98 may be substantially similar to a connector assembly described in U.S. Patent No. 8,109,889.

Connector assembly 98 is a bending resistant male-type connector disposed on the proximal end of guidewire 36 configured to conductively engage a female-type connector that is operatively connected to medical positioning system 20. Electric signals from sensor assembly 54 are communicated to the MPS 20 for determining a location reading of the sensor assembly 54, as described above.

[0057] In an embodiment, connector assembly 98 may comprise a plurality of insulator sleeves 102, a plurality of conductor rings 104, and a D-shaped pin 106. D-shaped pin 106 is positioned in a lumen of connector assembly 98, as shown in Figure 9. A distal end of D-shaped pin 106 is attached to proximal end of corewire 52 using adhesive 108 (e.g., epoxy). A proximal end of D-shaped pin 106 is attached to a proximal tip 107. D-shaped pin 106 may provide additional structure to connector assembly 98 as well as clearance for wire cable pass through the lumen of connector assembly 98. A first wire 74₁ of wire cable 74 is conductively connected to a first conductor ring 104₁. A second wire 74₂ of wire cable 74 is conductively connected to a second conductor ring 104₂. The distal end of connector assembly 98 is attached to a reduced diameter of the proximal end portion of body 90. Insulator sleeves 102 are positioned adjacent to conductor rings 104. The lumen of connector assembly 98 may be filled with an insulating material, such as epoxy, which may secure D-shaped pin 106, wire cable 74, insulator sleeves 102, and conductor rings 104 to connector assembly 98. The insulating material may also provide additional rigidity for connector assembly 98.

[0058] A method of manufacturing an embodiment of guidewire 36 will now be set forth. Body coil 88 is soldered to the distal end of body 90. Next, insulator tube 76 is placed onto corewire 52 (distal end) and then trimmed to length. Corewire 52 is bonded to sensor assembly 54 (e.g., using epoxy). The larger alignment tube 78 is then slid on over corewire 52 and cable 74. Once the leads 72 from sensor assembly 54 have been soldered to the distal end leads from wiring 74, then alignment tube 78 is slid into place over solder joints 80. Shroud 56 (e.g., shrink tube) is then placed over sensor assembly 54 and

alignment tube 78. Epoxy is introduced into cavity 73 (*i.e.*, interior of the shrink tube), using known means (*e.g.*, a needle). Heat is applied, which shrinks shrink tube 56 to the outside diameter of sensor assembly 54 and alignment tube 78, but also cures the epoxy. An additional dab of epoxy is applied to the distal end of guidewire 36, including corewire 52, thereby forming hemispherical plug 84. From the proximal end of body 90 of guidewire 36, wiring 74 (twisted pair) is pulled through for alignment at the proximal end. Body 90 is slid distally and body 90 (*i.e.*, the distal portion of body coil 88) is adhered (*e.g.*, epoxy) to sensor assembly 54 (see detail Fig. 5). The electrical connections between wiring 74 and proximal connector assembly 98 are made. Corewire 52 is also bonded to proximal connector assembly 98. The coating 60 is applied.

[0059] Figure 13 is a schematic and block diagram of one exemplary embodiment of MPS 20, designated as a MPS 110, as also seen by reference to U.S. Patent No. 7,386,339, referred to above, and portions of which are reproduced below, which generally describes, at least in part, the MediGuide™ Technology system commercially offered by MediGuide Ltd. of Haifa, Israel and now owned by St. Jude Medical, Inc. It should be understood that variations are possible, for example, as also seen by reference to U.S. Patent No. 6,233,476.

Another exemplary magnetic field-based MPS is the Car-to™ system commercially available from Biosense Webster, and as generally shown and described in, for example, U.S. Patent No. 6,498,944, and U.S. Patent No. 6,788,967.

Accordingly, the following description is exemplary only and not limiting in nature.

[0060] MPS 110 includes a location and orientation processor 150, a transmitter interface 152, a plurality of look-up table units 154₁, 154₂ and 154₃, a plurality of digital to analog converters (DAC) 156₁, 156₂ and 156₃, an amplifier 158, a transmitter 160, a plurality of MPS sensors 162₁, 162₂, 162₃ and 162_N, a plurality of analog to digital converters (ADC) 164₁, 164₂, 164₃ and 164_N and a sensor interface 166.

[0061] Transmitter interface 152 is connected to location and orientation processor 150 and to look-up table units 154₁, 154₂ and 154₃. DAC units 156₁, 156₂ and 156₃ are connected to a respective one of look-up table units 154₁, 154₂ and 154₃ and to amplifier 158. Amplifier 158 is further connected to transmitter 160. Transmitter 160 is also marked TX. MPS sensors 162₁, 162₂, 162₃ and 162_N are further marked RX₁, RX₂, RX₃ and RX_N, respectively. Analog to digital converters (ADC) 164₁, 164₂, 164₃ and 164_N are respectively connected to sensors 162₁, 162₂, 162₃ and 162_N and to sensor interface 166. Sensor interface 166 is further connected to location and orientation processor 150.

[0062] Each of look-up table units 154₁, 154₂ and 154₃ produces a cyclic sequence of numbers and provides it to the respective DAC unit 156₁, 156₂ and 156₃, which in turn translates it to a respective analog signal. Each

of the analog signals is respective of a different spatial axis. In the present example, look-up table 154₁ and DAC unit 156₁ produce a signal for the X axis, look-up table 154₂ and DAC unit 156₂ produce a signal for the Y axis and look-up table 154₃ and DAC unit 156₃ produce a signal for the Z axis.

[0063] DAC units 156₁, 156₂ and 156₃ provide their respective analog signals to amplifier 158, which amplifies and provides the amplified signals to transmitter 160. Transmitter 160 provides a multiple axis electromagnetic field, which can be detected by MPS sensors 162₁, 162₂, 162₃ and 162_N. Each of MPS sensors 162₁, 162₂, 162₃ and 162_N detects an electromagnetic field, produces a respective electrical analog signal and provides it to the respective ADC unit 164₁, 164₂, 164₃ and 164_N connected thereto. Each of the ADC units 164₁, 164₂, 164₃ and 164_N digitizes the analog signal fed thereto, converts it to a sequence of numbers and provides it to sensor interface 166, which in turn provides it to location and orientation processor 150. Location and orientation processor 150 analyzes the received sequences of numbers, thereby determining the location and orientation of each of the MPS sensors 162₁, 162₂, 162₃ and 162_N. Location and orientation processor 150 further determines distortion events and updates look-up tables 154₁, 154₂ and 154₃, accordingly.

[0064] It should be understood that system 10, particularly the main electronic control unit 12, as described above may include conventional processing apparatus known in the art, capable of executing pre-programmed instructions stored in an associated memory, all performing in accordance with the functionality described herein. Such an electronic control unit may further be of the type having both ROM, RAM, a combination of non-volatile and volatile (modifiable) memory so that any software may be stored and yet allow storage and processing of dynamically produced data and/or signals.

[0065] Although only certain embodiments have been described above with a certain degree of particularity, those skilled in the art could make numerous alterations to the disclosed embodiments without departing from the scope of this disclosure. Joinder references (*e.g.*, attached, coupled, connected, and the like) are to be construed broadly and may include intermediate members between a connection of elements and relative movement between elements. As such, joinder references do not necessarily infer that two elements are directly connected/coupled and in fixed relation to each other. Additionally, the terms "electrically connected" and "in communication" are meant to be construed broadly to encompass both wired and wireless connections and communications. It is intended that all matter contained in the above description or shown in the accompanying drawings shall be interpreted as illustrative only and not limiting. Changes in detail or structure may be made without departing from the invention as defined in the appended claims.

Claims**1.** A guidewire (36) comprising:

an elongate body (90) formed from a tube including proximal and distal end portions, the elongate body (90) further including an annular wall (94) that defines an interior lumen (96);

a proximal connector assembly (98) connected to the proximal end portion of the elongate body (90), the proximal connector assembly (98) being configured for connection to a medical positioning system (MPS);

a corewire (52) including proximal and distal end portions, the corewire (52) extending through the interior lumen (96);

a sensor assembly (54) located on the distal end portion of the corewire (52) and distal of the elongate body (90), the sensor assembly (54) being electrically connected by a pair of electrical conductors (74₁, 74₂) to the proximal connector assembly (98);

an electrically insulating structure (76) that surrounds the corewire (52) and insulates the corewire (52) from the pair of electrical conductors (74₁, 74₂), and

a D-shaped pin (106) including proximal and distal end portions,

wherein the distal end portion of the D-shaped pin (106) is connected to the proximal end portion of the corewire (52) and the proximal end portion of the D-shaped pin (106) is connected to a proximal end of the proximal connector assembly (98),

wherein the D-shaped pin (106) is configured to provide clearance for the electrical conductors (74₁, 74₂) to pass through the elongate connector assembly (98).

2. The guidewire (36) of claim 1, wherein the insulating structure (76) that surrounds the corewire (52) is a tube, or comprises a heat shrink material, or comprises a coating.

3. The guidewire (36) of claim 1 or 2, wherein the electrically insulating structure (76) electrically isolates the corewire (52) from the pair of electrical conductors (74₁, 74₂).

4. The guidewire (36) of anyone of claims 1 to 3, further comprising:

a plug (58) coupled with the distal end portion of the corewire (52), wherein the plug (58) has a distal, non-traumatic tip portion.

5. The guidewire (36) of anyone of claims 1 to 4, wherein the sensor assembly (54) and the pair of electrical conductors (74₁, 74₂) are electrically connected at

a pair of connection nodes (80₁, 80₂), further including:

an alignment tube (78) proximal of the sensor assembly (54) configured in size to enclose the connection nodes (80₁, 80₂), to thereby protect the connection nodes (80₁, 80₂) from external forces, preferably

wherein the electrically insulating structure (76) electrically isolates the corewire (52) from the pair of connection nodes (80₁, 80₂).

6. The guidewire (36) of anyone of claims 1 to 5, wherein the proximal connector assembly (98) defines an elongate connector assembly lumen.

7. The guidewire (36) of anyone of claims 1 to 6, wherein the configured-shaped pin (106) extends through a portion of the elongate connector assembly lumen and along a length of the proximal connector assembly (98).

8. The guidewire (36) of anyone of claims 1 to 7, wherein the proximal connector assembly (98) includes a pair of conductor rings (104) disposed along the length of the proximal connector assembly which the D-shaped pin (106) extends.

9. The guidewire (36) of anyone of claims 6 to 8, wherein the pair of conductor rings (104) are electrically coupled with the corewire (52) via the pair of electrical conductors (74₁, 74₂).

10. The guidewire (36) of anyone of claims 1 to 9, wherein the proximal end portion of the core wire (52) is disposed proximally with respect to a distal end of the proximal connector assembly (98).

11. The guidewire (36) of anyone of claims 6 to 10, wherein the distal end portion of the pin (106) is disposed proximally with respect to the distal end of the proximal connector assembly (98), or wherein the proximal end portion of the elongate body (90) has a reduced diameter with respect to the distal end portion, and the distal end of the proximal connector assembly (98) is connected to the proximal end portion of the elongate body (90).

12. The guidewire (36) of anyone of claims 5 to 11, further comprising:

a coil (88) positioned proximally with respect to the sensor assembly (54), the coil (88) being coaxial with the axis of the elongate body (90); wherein

the alignment tube (78) is disposed between the sensor assembly (54) and the coil (88), the alignment tube (78) being coaxial with the axis of the

elongate body (90).

Patentansprüche

1. Führungsdraht (36), enthaltend:

einen langgestreckten Körper (90), der aus einem Schlauch gebildet ist, der einen nahen und einen entfernten Endbereich aufweist, wobei der langgestreckte Körper (90) ferner eine ringförmige Wand (94) aufweist, die ein Innenlumen (96) definiert;

eine nahe Verbinderbaugruppe (98), die mit dem nahen Endbereich des langgestreckten Körpers (90) verbunden ist, wobei die nahe Verbinderbaugruppe (98) zum Verbinden mit einem medizinischen Positionierungssystem (MPS) ausgebildet ist;

einen Kerndraht (52), der einen nahen und einen entfernten Endbereich aufweist, wobei der Kerndraht (52) sich durch das Innenlumen (96) erstreckt;

eine Sensorbaugruppe (54), die sich auf dem entfernten Endbereich des Kerndrahts (52) und entfernt des langgestreckten Körpers (90) befindet, wobei die Sensorbaugruppe (54) elektrisch durch ein Paar elektrische Leiter (74₁, 74₂) mit der nahen Verbindergruppe (98) verbunden ist;

eine elektrisch isolierende Struktur (76), die den Kerndraht (52) umgibt und den Kerndraht (52) von dem Paar elektrischer Leiter (74₁, 74₂) isoliert, und

einen D-förmigen Stift (106), der einen nahen und einen entfernten Endbereich aufweist, wobei der entfernte Endbereich des D-förmigen Stifts (106) mit dem nahen Endbereich des Kerndrahts (52) verbunden ist und der nahe Endbereich des D-förmigen Stifts (106) mit einem nahen Ende der nahen Verbinderbaugruppe (98) verbunden ist;

wobei der D-förmige Stift (106) zum Vorsehen eines Freiraums für die elektrischen Leiter (74₁, 74₂) zum Durchlaufen der langgestreckten Verbinderbaugruppe (98) ausgebildet ist.

2. Führungsdraht (36) nach Anspruch 1, wobei die isolierende Struktur (76), die den Kerndraht (52) umgibt, ein Schlauch ist oder ein Wärmeschrumpfmateriale aufweist oder eine Beschichtung aufweist.

3. Führungsdraht (36) nach Anspruch 1 oder 2, wobei die elektrisch isolierende Struktur (76) den Kerndraht (52) elektrisch von dem Paar elektrischer Leiter (74₁, 74₂) isoliert.

4. Führungsdraht (36) nach einem der Ansprüche 1 bis

3, ferner enthaltend:

einen Stopfen (58), der mit dem entfernten Endbereich des Kerndrahts (52) gekoppelt ist, wobei der Stopfen (58) einen entfernten, nicht-traumatisierenden Spitzenbereich aufweist.

5. Führungsdraht (36) nach einem der Ansprüche 1 bis 4, wobei die Sensorbaugruppe (54) und das Paar elektrischer Leiter (74₁, 74₂) elektrisch mit einem Paar von Verbindungsknoten (80₁, 80₂) verbunden sind, ferner enthaltend:

ein Ausrichtungsrohr (78) nahe der Sensorbaugruppe (54), das in seiner Größe derart ausgebildet ist, dass es die Verbindungsknoten (80₁, 80₂) umschließt, so dass es dadurch die Verbindungsknoten (80₁, 80₂) vor äußeren Kräften schützt, bevorzugt wobei die elektrisch isolierende Struktur (76) den Kerndraht (52) von dem Paar von Verbindungsknoten (80₁, 80₂) elektrisch isoliert.

6. Führungsdraht (36) nach einem der Ansprüche 1 bis 5, wobei die nahe Verbinderbaugruppe (98) ein langgestrecktes Verbinderbaugruppenlumen definiert.

7. Führungsdraht (36) nach einem der Ansprüche 1 bis 6, wobei der geformt ausgebildete Stift (106) sich durch einen Bereich des langgestreckten Verbinderbaugruppenlumens und entlang einer Länge der nahen Verbinderbaugruppe (98) erstreckt.

8. Führungsdraht (36) nach einem der Ansprüche 1 bis 7, wobei die nahe Verbinderbaugruppe (98) ein Paar Leiterringe (104) aufweist, die entlang der Länge der nahen Verbinderbaugruppe angeordnet sind, in der sich der D-förmige Stift (106) erstreckt.

9. Führungsdraht (36) nach einem der Ansprüche 6 bis 8, wobei das Paar von Leiterringen (104) elektrisch mit dem Kerndraht (52) über das Paar elektrischer Leiter (74₁, 74₂) gekoppelt ist.

10. Führungsdraht (36) nach einem der Ansprüche 1 bis 9, wobei der nahe Endbereich des Kerndrahts (52) mit Bezug auf ein entferntes Ende der nahen Verbinderbaugruppe (98) nahe angeordnet ist.

11. Führungsdraht (36) nach einem der Ansprüche 6 bis 10, wobei der entfernte Endbereich des Stifts (106) mit Bezug auf das entfernte Ende der nahen Verbinderbaugruppe (98) nahe angeordnet ist, oder wobei der nahe Endbereich des langgestreckten Körpers (90) einen reduzierten Durchmesser mit Bezug auf den entfernten Endbereich aufweist und das entfernte Ende der nahen Verbinderbaugruppe (98) mit dem nahen Endbereich des langgestreckten Körpers (90) verbunden ist.

12. Führungsdraht (36) nach einem der Ansprüche 5 bis 11, ferner enthaltend:

eine Spule (88), die mit Bezug auf die Sensorbaugruppe (54) nahe angeordnet ist, wobei die Spule (88) koaxial zu der Achse des langgestreckten Körpers (90) ist; wobei das Ausrichtungsrohr (78) zwischen der Sensorbaugruppe (54) und der Spule (88) angeordnet ist, wobei das Ausrichtungsrohr (78) koaxial zu der Achse des langgestreckten Körpers (90) ist.

Revendications

1. Fil-guide (36) comprenant :

un corps allongé (90) formé d'un tube comprenant une extrémité proximale et distale, le corps allongé (90) comprenant en outre une paroi annulaire (94) qui définit une lumière intérieure (96) ;

un ensemble de connecteur proximal (98) relié à la partie d'extrémité proximale du corps allongé (90), l'ensemble de connecteur proximal (98) étant configuré pour la connexion à un système de positionnement médical (MPS);

un fil central (52) comprenant des parties d'extrémité proximale et distale, le fil central (52) s'étendant à travers la lumière intérieure (96) ;

un ensemble de capteur (54) situé sur la partie d'extrémité distale du fil central (52) et distal du corps allongé (90), l'ensemble de capteur (54) étant relié électriquement par une paire de conducteurs électriques (74₁, 74₂) à l'ensemble de connecteur proximal (98) ;

une structure électriquement isolante (76) qui entoure le fil central (52) et isole le fil central (52) de la paire de conducteurs électriques (74₁, 74₂), et

une broche en forme de D (106) comprenant des parties d'extrémité proximale et distale, où la partie d'extrémité distale de la broche en forme de D (106) est reliée à la partie d'extrémité proximale du fil central (52) et la partie d'extrémité proximale de la broche en forme de D (106) est reliée à une extrémité proximale de l'ensemble de connecteur proximal (98),

où la broche en forme de D (106) est configurée pour fournir un jeu pour les conducteurs électriques (74₁, 74₂) pour passer à travers l'ensemble de connecteur proximal (98).

2. Fil-guide (36) selon la revendication 1, où la structure isolante (76) qui entoure le fil central (76) est un tube, ou comprend un matériau thermo rétractable, ou comprend un revêtement.

3. Fil-guide (36) selon la revendication 1 ou 2, dans lequel la structure électriquement isolante (76) isole électriquement le fil central (52) de la paire de conducteurs électriques (74₁, 74₂).

4. Fil-guide (36) selon l'une quelconque des revendications 1 à 3, comprenant en outre : une fiche (58) couplée à la partie d'extrémité distale du fil central (52), où la fiche (58) a une partie d'extrémité distale, non traumatique.

5. Fil-guide (36) selon l'une quelconque des revendications 1 à 4, dans lequel l'ensemble de capteur (54) et la paire de conducteurs électriques (74₁, 74₂) sont reliés électriquement à une paire de noeuds de connexion (80₁, 80₂), comprenant en outre :

un tube d'alignement (78) proximal de l'ensemble capteur (54) configuré en taille pour enfermer les noeuds de connexion (80₁, 80₂), afin de protéger ainsi les noeuds de connexion (80₁, 80₂) de forces extérieures, de préférence où la structure électriquement isolante (76) isole électriquement le fil central (52) de la paire de noeuds de connexion (80₁, 80₂).

6. Fil-guide (36) selon l'une quelconque des revendications 1 à 5, où l'ensemble de connecteur proximal (98) définit une lumière d'ensemble connecteur allongée.

7. Fil-guide (36) selon l'une quelconque des revendications 1 à 6, où la broche de formée configurée (106) s'étend à travers une partie de la lumière d'ensemble de connecteur allongé et le long d'une longueur de l'ensemble de connecteur proximal (98).

8. Fil-guide (36) selon l'une quelconque des revendications 1 à 7, dans lequel l'ensemble de connecteur proximal (98) comprend une paire d'anneaux conducteurs (104) disposés le long de la longueur de l'ensemble de connecteur proximal que la broche en forme de D (106) prolonge.

9. Fil-guide (36) selon l'une quelconque des revendications 6 à 8, dans lequel la paire d'anneaux conducteurs (104) est couplée électriquement au fil central (52) via la paire de conducteurs électriques (74₁, 74₂).

10. Fil-guide (36) selon l'une quelconque des revendications 1 à 9, dans lequel la partie d'extrémité proximale du fil central (52) est disposée de manière proximale par rapport à une extrémité distale de l'ensemble de connecteur proximal (98).

11. Fil-guide (36) selon l'une quelconque des revendications 6 à 10, où la partie d'extrémité distale de la

broche (106) est disposée de manière proximale par rapport à l'extrémité distale de l'ensemble de connecteur proximal (98), ou où la partie d'extrémité proximale du corps allongé (90) a un diamètre réduit par rapport à la partie d'extrémité distale et à l'extrémité distale de l'ensemble de connecteur proximal (98) est reliée à la partie d'extrémité proximale du corps allongé (90).

5

12. Fil-guide (36) selon l'une quelconque des revendications 5 à 11, comprenant en outre :

10

une bobine (88) positionnée de manière proximale par rapport à l'ensemble de capteur (54), la bobine (88) étant coaxiale avec l'axe du corps allongé (90) ; où

15

le tube d'alignement (78) est disposé entre l'ensemble de capteur (54) et la bobine (88), le tube d'alignement (78) étant coaxial avec l'axe du corps allongé (90).

20

25

30

35

40

45

50

55

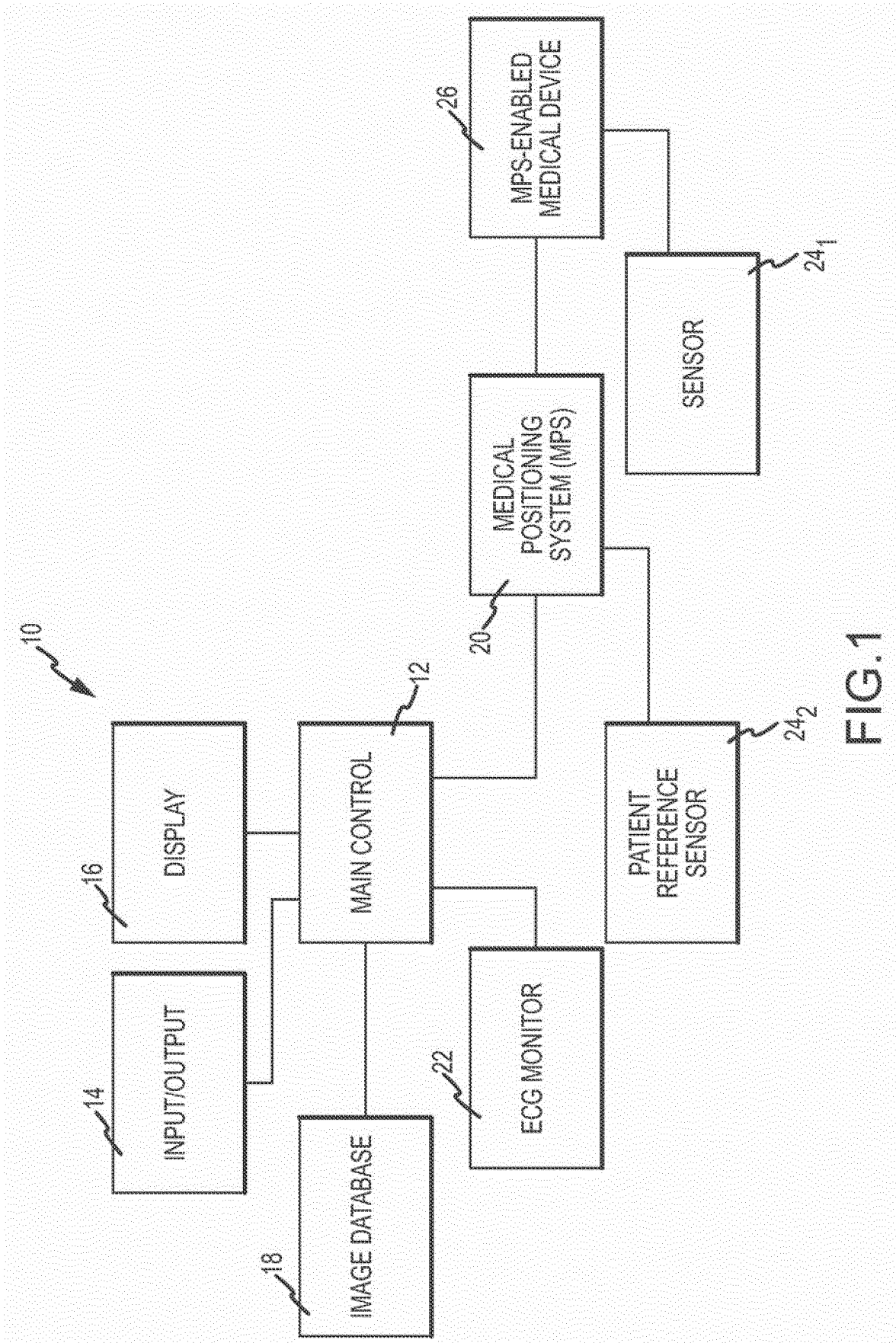

FIG. 1

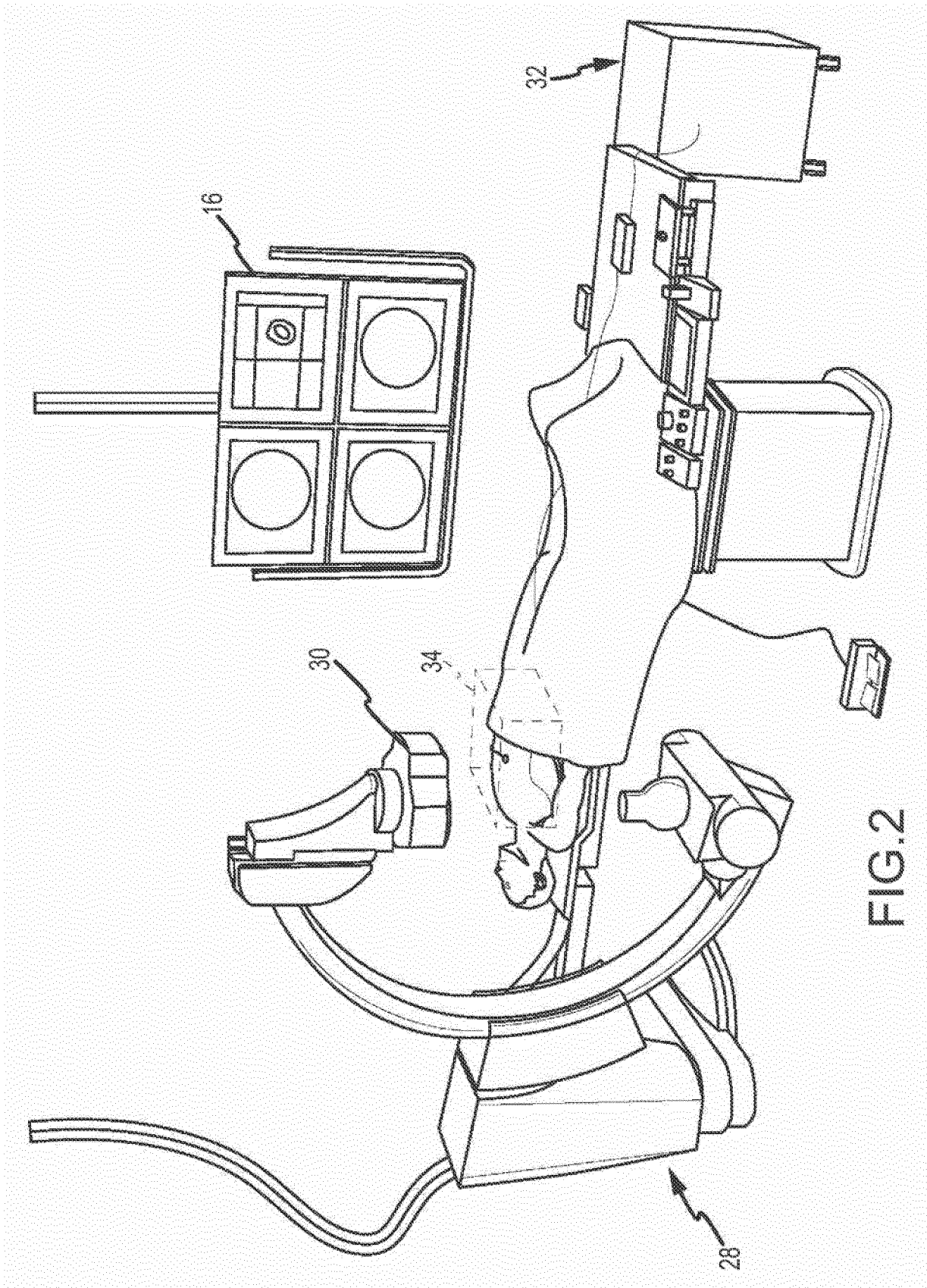

FIG. 2

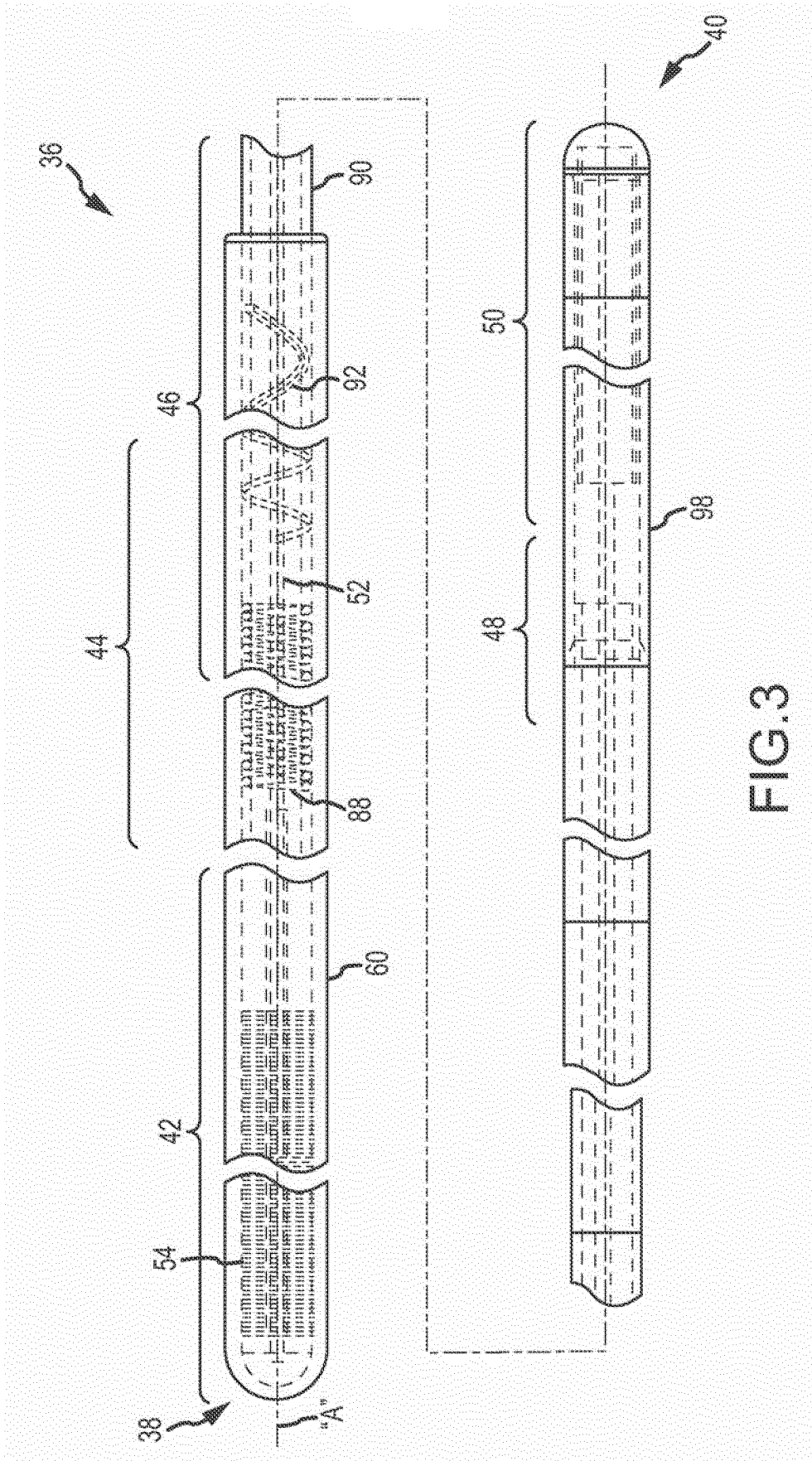
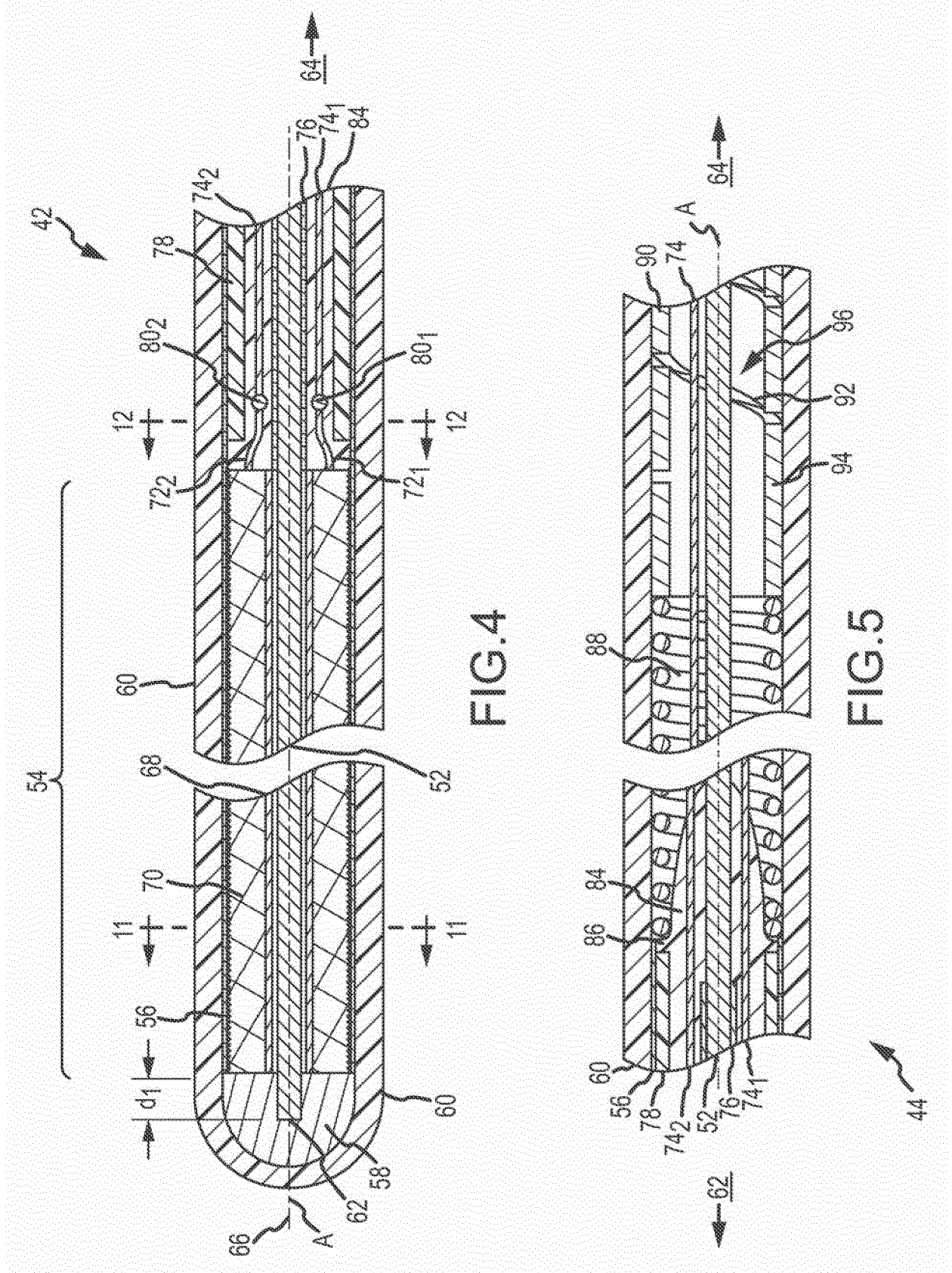

FIG.3



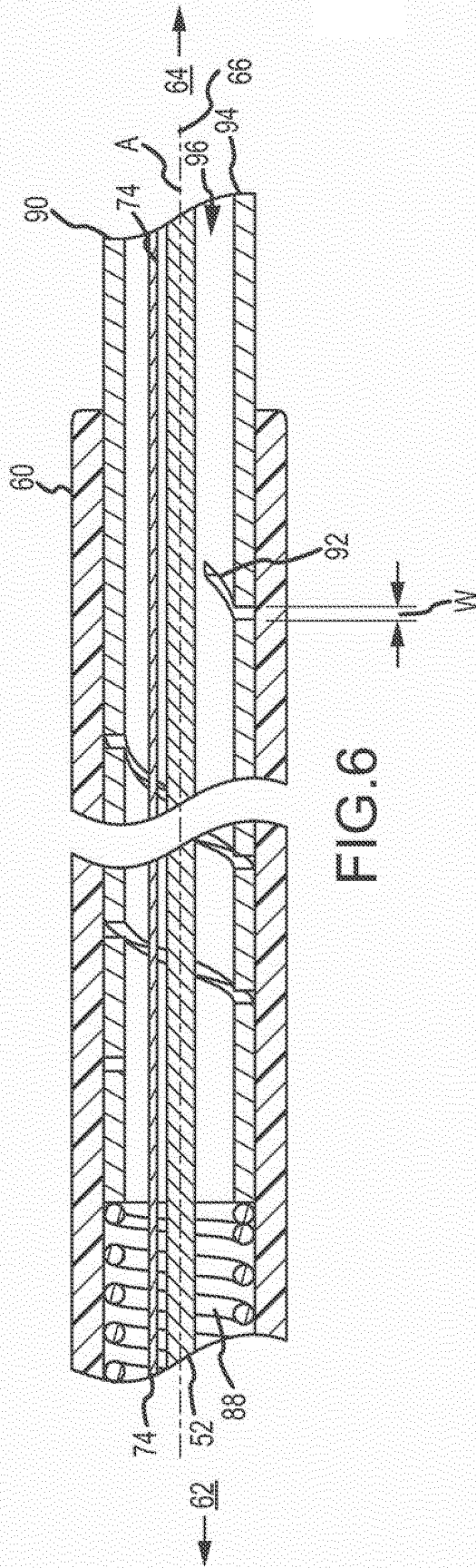

FIG. 6

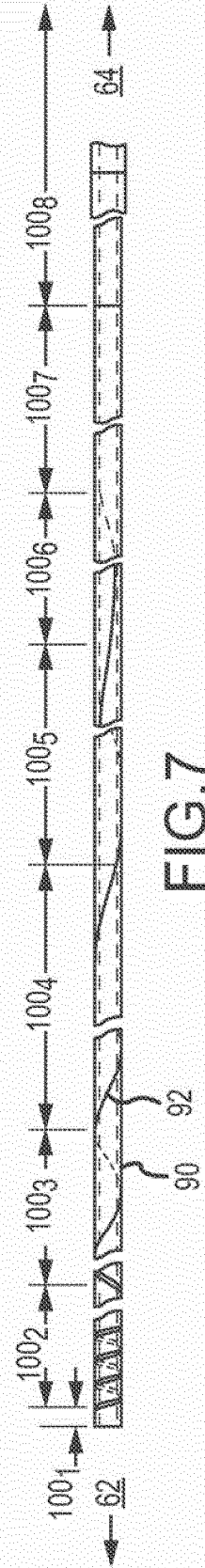

FIG. 7

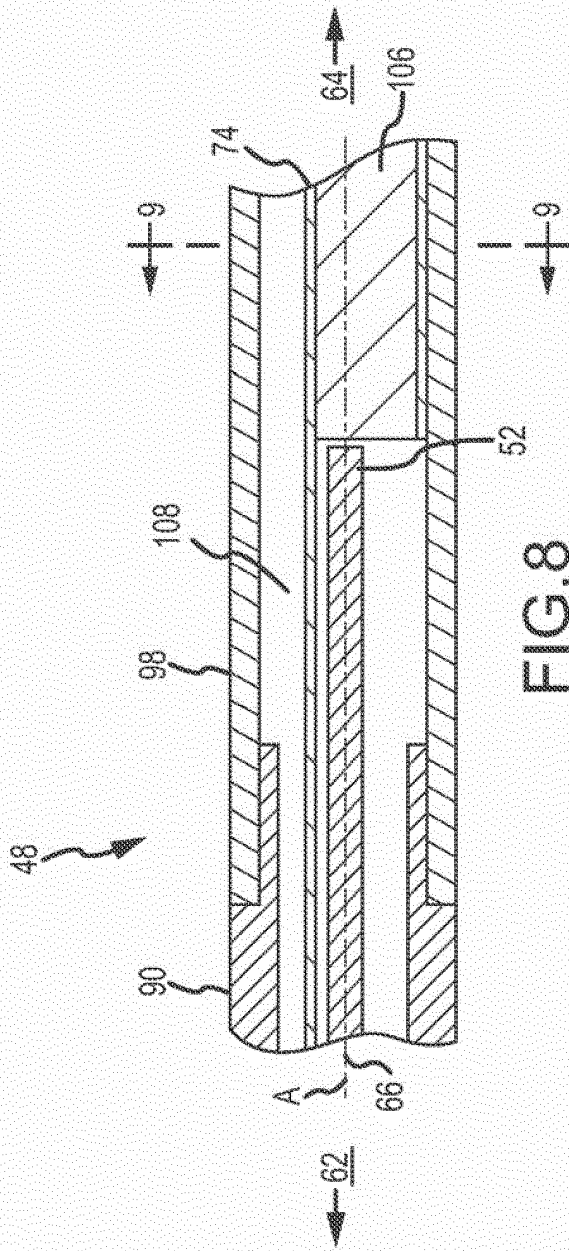

FIG. 8

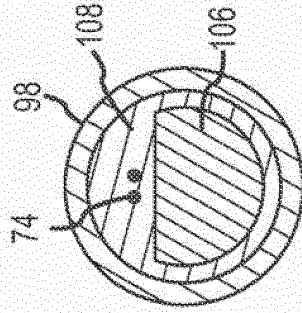

FIG. 9

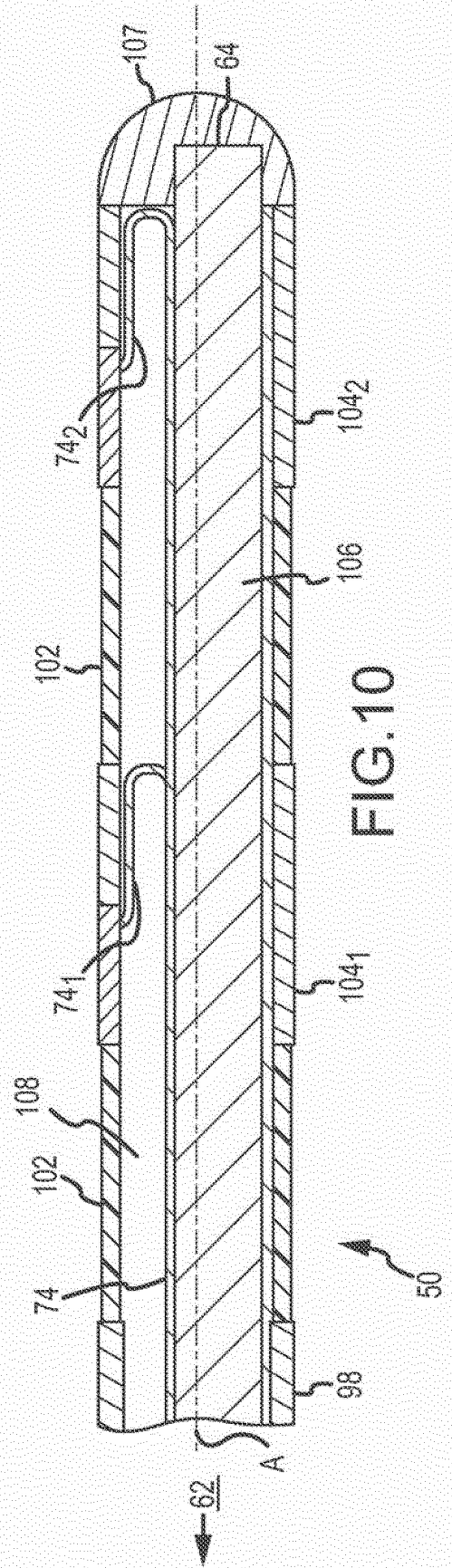
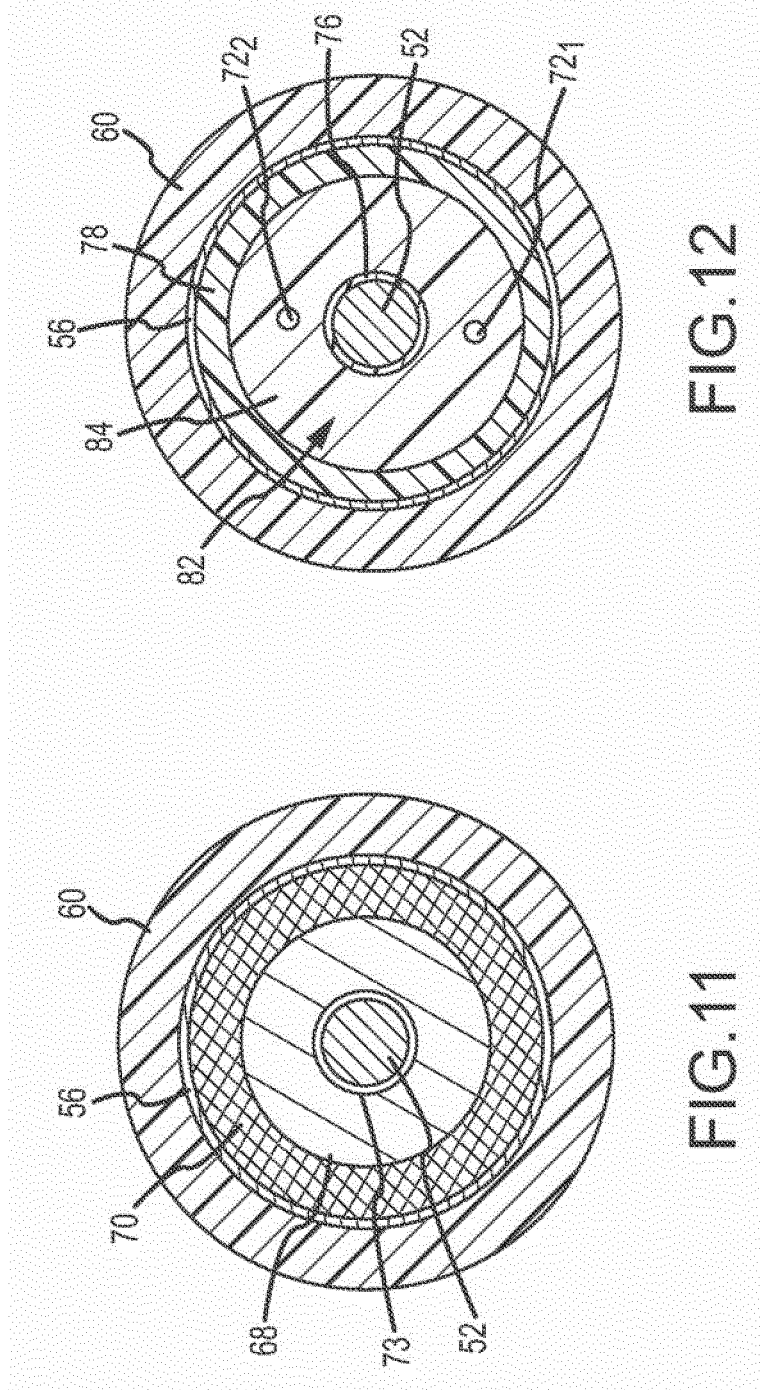
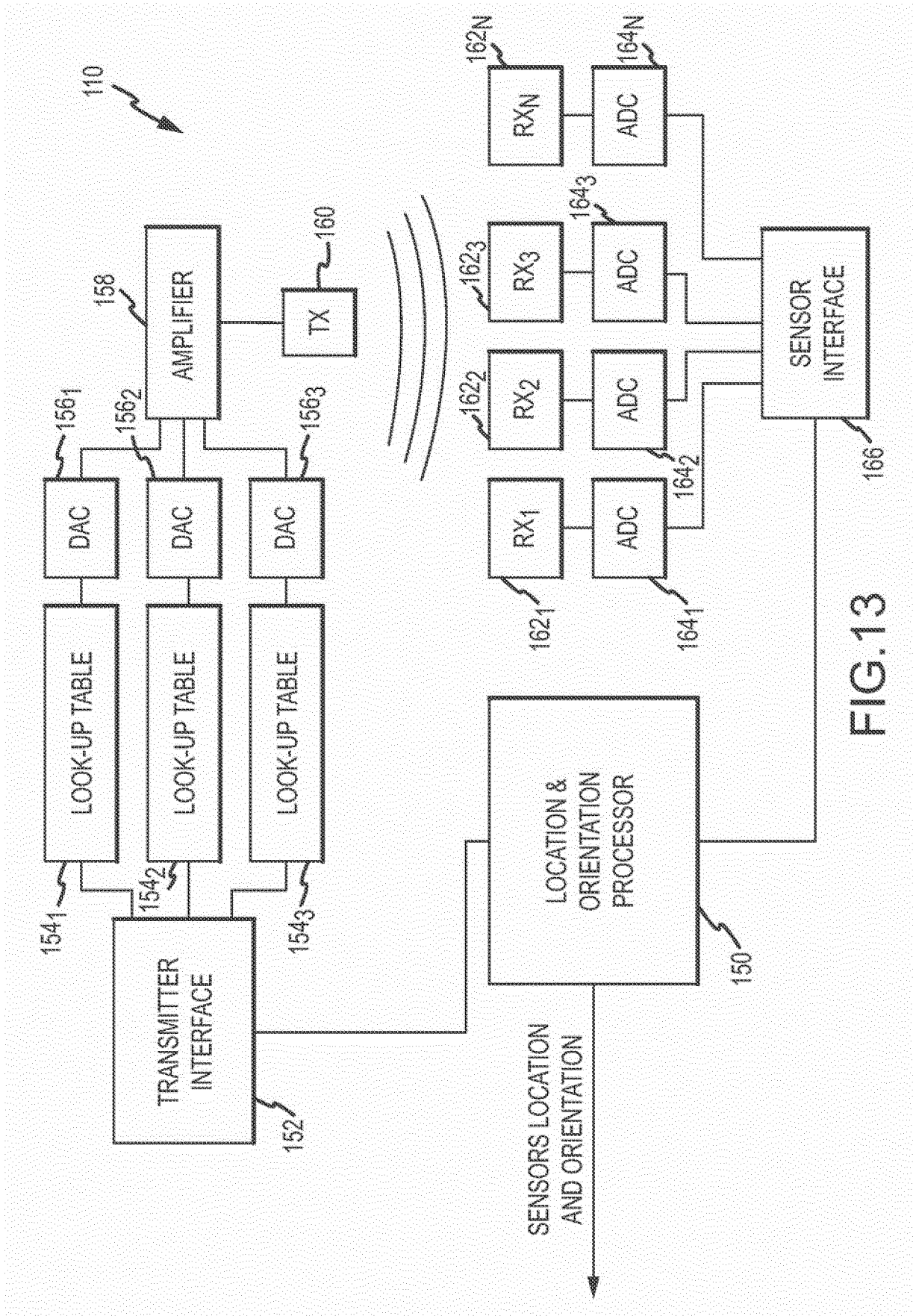

FIG. 10





REFERENCES CITED IN THE DESCRIPTION

This list of references cited by the applicant is for the reader's convenience only. It does not form part of the European patent document. Even though great care has been taken in compiling the references, errors or omissions cannot be excluded and the EPO disclaims all liability in this regard.

Patent documents cited in the description

- US 2008132806 A1 [0002]
- EP 0367472 A1 [0002]
- WO 9913532 A1 [0002]
- EP 0925803 A2 [0002]
- EP 0419277 A1 [0002]
- US 12357971 B [0003]
- US 20090192412 A1 [0003]
- US 12359010 B [0030]
- US 20090192413 A1 [0030]
- US 98084810 A [0032]
- US 8109889 B [0056]
- US 7386339 B [0059]
- US 6233476 B [0059]
- US 6498944 B [0059]
- US 6788967 B [0059]

| | | | |
|----------------|--|---------|------------|
| 专利名称(译) | 具有螺旋切口和涂层的医疗设备导丝 | | |
| 公开(公告)号 | EP3150116B1 | 公开(公告)日 | 2019-06-05 |
| 申请号 | EP2016190819 | 申请日 | 2013-04-17 |
| [标]申请(专利权)人(译) | 圣犹达医疗用品电生理部门有限公司 | | |
| 申请(专利权)人(译) | ST.犹达医疗心房颤动DIVISION INC. | | |
| 当前申请(专利权)人(译) | ST.犹达医疗心房颤动DIVISION INC. | | |
| [标]发明人 | VANNEY GUY P GUSTAFSSON PAR | | |
| 发明人 | VANNEY, GUY, P. GUSTAFSSON, PAR | | |
| IPC分类号 | A61B18/00 A61B5/00 A61M25/09 A61B5/0245 A61B5/06 A61M25/00 A61B34/20 | | |
| 优先权 | 13/465866 2012-05-07 US PCT/US2013/036994 2013-04-17 WO | | |
| 其他公开文献 | EP3150116A3 EP3150116A2 | | |
| 外部链接 | Espacenet | | |

摘要(译)

公开了一种用于医疗装置的导丝 (36)。导丝包括细长主体 (90)，近端连接器组件 (98)，芯线 (52) 和传感器组件 (54)。主体具有环形壁 (94)，其限定内腔 (96)。近端连接器组件连接到主体并且配置成连接到医疗定位系统 (20)。芯线延伸通过内腔。位于芯线的远端上的传感器组件电连接到近端连接器组件。传感器组件被配置为产生电信号，该电信号指示传感器组件在由医疗定位系统限定的参考坐标系中的位置，该参考坐标系由一对导体 (74) 和电绝缘结构 (76) 电连接。环绕铁芯线并使铁芯线与两对电导线绝缘。

