

(19)



(11)

EP 2 981 326 B1

(12)

EUROPEAN PATENT SPECIFICATION

(45) Date of publication and mention of the grant of the patent:
23.05.2018 Bulletin 2018/21

(51) Int Cl.:
A61N 1/04 (2006.01) **A61N 1/18** (2006.01)
A61N 1/36 (2006.01) **A61F 5/34** (2006.01)
A61B 5/00 (2006.01) **A61B 5/0478** (2006.01)

(21) Application number: **14764750.7**

(86) International application number:
PCT/IB2014/059858

(22) Date of filing: **15.03.2014**

(87) International publication number:
WO 2014/141213 (18.09.2014 Gazette 2014/38)

(54) HEADSET FOR TREATMENT AND ASSESSMENT OF MEDICAL CONDITIONS

KOPFHÖRER ZUR BEHANDLUNG UND ÜBERPRÜFUNG MEDIZINISCHER LEIDEN

CASQUE POUR LE TRAITEMENT ET L'ÉVALUATION DE PATHOLOGIES MÉDICALES

(84) Designated Contracting States:
AL AT BE BG CH CY CZ DE DK EE ES FI FR GB GR HR HU IE IS IT LI LT LU LV MC MK MT NL NO PL PT RO RS SE SI SK SM TR

- **COHEN, Amir**
4358818 Ra'anana (IL)
- **BELSON, Ron**
6291412 Tel-Aviv (IL)

(30) Priority: **15.03.2013 US 201361786701 P**

(74) Representative: **Harrison IP Limited**
3 Ebor House
Millfield Lane
Nether Poppleton, York YO26 6QY (GB)

(43) Date of publication of application:
10.02.2016 Bulletin 2016/06

(73) Proprietor: **Neurolif Ltd.**
4672514 Hertzelia (IL)

(56) References cited:
WO-A1-97/43954 **WO-A1-2012/079778**
WO-A1-2012/079778 **WO-A1-2012/155117**
WO-A2-2013/001526 **US-A- 3 659 614**
US-A- 5 495 853 **US-A- 6 077 237**
US-A1- 2001 039 444

(72) Inventors:
 • **DAR, Amit**
4069200 Kfar-Hess (IL)
 • **BAR-OR, Jonathan**
3712583 Pardes-Hana Karkur (IL)

EP 2 981 326 B1

Note: Within nine months of the publication of the mention of the grant of the European patent in the European Patent Bulletin, any person may give notice to the European Patent Office of opposition to that patent, in accordance with the Implementing Regulations. Notice of opposition shall not be deemed to have been filed until the opposition fee has been paid. (Art. 99(1) European Patent Convention).

DescriptionFIELD OF THE INVENTION

[0001] The present invention relates to apparatus and methods for applying electrical stimulation to the head region, to headsets having electrodes for treatment of medical conditions using non-invasive electrical stimulation, to headsets adapted to assess medical conditions, and to electrode arrangements for use with such headsets.

SUMMARY OF THE INVENTION

[0002] According to some teachings of the present invention there is provided a headset for use in delivering electrical stimulation to a skin surface of a head of a user, the headset including: (a) a circumferential headset body, the body having a monolithic frame adapted to circumferentially fit around the head of the user, the body housing an electric circuit adapted to be connected to a power source; the headset body including an elastic arrangement, disposed on at least a portion of a circumference of the headset body; the elastic arrangement adapted to be tensioned along the circumference; (b) at least one electrode base, mechanically and at least semi-rigidly connected to the headset body, and electrically associated with the electric circuit, the electrode base adapted to receive at least one electrode pad; the headset body and the base adapted to orient a electrical stimulation surface of the pad towards the skin surface, during donning by the user; the elastic arrangement adapted such that, during the donning, the elastic arrangement radially urges the electrode base towards the skin surface such that the electrode pad makes physical and electrical contact with the skin surface; the elastic arrangement and the electrode base adapted such that for various degrees of tensioning of the elastic arrangement, a circumferential position of the electrode base, with respect to the frame, is fixed in a unique position.

[0003] According to another aspect of the present invention there is provided a electrode pad including: (a) a water-absorbent layer having a biocompatible, conductive contact surface, the contact surface adapted to be juxtaposed against the skin surface; (b) an electrically conductive layer having a broad first face attached to the water-absorbent layer, the conductive layer containing a carbon foil or carbon film, the conductive layer adapted to transfer an electrical current from a broad second face, distal to the first face, to the water-absorbent layer, via the first face, the water-absorbent layer and the electrically conductive layer forming an integral structure.

[0004] According to yet another aspect of the present invention there is provided an electrode base having: (a) a housing including a floor, and a flexible circumferential member surrounding the floor, and having a flexible circumferential wall extending generally above a perimeter of the floor, the wall ending in a circumferential rim; the

floor and the flexible circumferential member forming a cavity adapted to receive an electrically conductive electrode pad; and (b) an electrically conductive material, disposed at least partially above, or within, the floor; the conductive layer adapted to be electrically associated to an electrical circuit, by means of an electrical conductor, and, when the pad is inserted, to electrically communicate, in an operational mode, with the electrode pad; the rim and the flexible circumferential wall adapted such that a pressure exerted against the electrode base, generally perpendicular to the rim, and towards a skin surface of a user, urges the rim against the skin surface, to substantially fluidly seal between the cavity and an ambient or external environment.

[0005] According to yet another aspect of the present invention there is provided a biocompatible electrode for juxtaposing against a skin surface of a user, the electrode including: (a) a water-absorbent layer having a biocompatible contact surface, the contact surface adapted to be juxtaposed against the skin surface; (b) an electrode backing, attached to the water-absorbent layer, the backing containing at least one electrically conductive material or element, the conductive material or element being electrically connected, in an operational mode, with the water-absorbent layer, when the water-absorbent layer is filled with water; the biocompatible contact surface having: (i) a long dimension (D_L) having a maximum length of 20mm to 55mm; (ii) a narrow dimension (D_N) having a maximum length of 10mm to 25mm; a first side of a perimeter of the biocompatible contact surface having a generally concave contour having a concavity defined by first and second boundary points disposed at opposite ends of the concavity, wherein:

$$A/L \geq 0.5\text{mm}$$

A being an area bounded by the line and the concavity; **L** being a length of a line between the boundary points; the length (**L**) being at least 10mm; a line disposed between a first point on the concave contour and a second point on the perimeter, on a side opposite the concave contour, and aligned in perpendicular fashion with respect to the contour at the first point, having a length **H**, and wherein, over an entirety of the concave contour,

$$H_{\max}/H_{\min} \leq 2.5,$$

H_{max} being a maximum value of H over the entirety; and

H_{min} being a minimum value of H over the entirety.

[0006] According to yet another aspect of the present invention, there are provided methods of donning and positioning the headset on the head of the user, substantially as described herein.

[0007] According to further features in the described

preferred embodiments, the circumferential headset body has a front section adapted to fit around a front portion of the head, and the at least one electrode base is a front electrode base disposed on the front portion.

[0008] According to still further features in the described preferred embodiments, the front section is a front mechanical element that is physically distinct from the circumferential headset body.

[0009] According to still further features in the described preferred embodiments, the front mechanical element spans at most 40%, at most 35%, at most 30%, or at most 20%, of a circumference of the circumferential headset body.

[0010] According to still further features in the described preferred embodiments, the front mechanical element spans within a range of 10% to 40%, 15% to 40%, 20% to 40%, 25% to 40%, or 25% to 35%, of a circumference of the circumferential headset body.

[0011] According to still further features in the described preferred embodiments, the circumferential headset body has a rear section adapted to fit around a rear portion of the head, and the at least one electrode base includes a rear electrode base disposed on the rear portion.

[0012] According to still further features in the described preferred embodiments, the rear section is a rear mechanical element that is physically distinct from the circumferential headset body.

[0013] According to still further features in the described preferred embodiments, the rear mechanical element spans at most 40%, at most 35%, at most 30%, or at most 20%, of a circumference of the circumferential headset body.

[0014] According to still further features in the described preferred embodiments, the rear mechanical element spans within a range of 10% to 40%, 15% to 40%, 20% to 40%, 25% to 40%, or 25% to 35%, of a circumference of the circumferential headset body.

[0015] According to still further features in the described preferred embodiments, the front and rear mechanical elements span, in total, 45% to 75%, 50% to 75%, 55% to 75%, or 55% to 70%, of the circumference.

[0016] According to still further features in the described preferred embodiments, the frame includes at least semi-rigid side components, bi-laterally disposed on the frame, and forming side portions of the circumference of the headset body.

[0017] According to still further features in the described preferred embodiments, the side components span, in total, 15% to 50%, 20% to 50%, 25% to 50%, 30% to 50%, 35% to 50%, or 30% to 45%, of the circumference.

[0018] According to still further features in the described preferred embodiments, each of the side components has an element disposed generally perpendicular to the circumference, and adapted, in a donned mode, to fit behind an ear of the user.

[0019] According to still further features in the de-

scribed preferred embodiments, the circumferential rigidity of the side components exceeds a circumferential rigidity of the front section and the rear section.

[0020] According to still further features in the described preferred embodiments, the circumferential elasticity of the front section and the rear section exceed a circumferential elasticity of the side components.

[0021] According to still further features in the described preferred embodiments, the frame includes a positioning system for angular and longitudinal positioning of the headset body, the positioning system including at least one at least semi-rigid side component, the side component having: a first, elongated element, forming a portion of the circumference, and adapted to fit above an ear of the user, to determine the longitudinal positioning, and a second element disposed generally perpendicular to the elongated element, and adapted to fit behind the ear, to determine the angular positioning of the headset body.

[0022] According to still further features in the described preferred embodiments, the frame includes at least a first bi-lateral size adjustment mechanism adapted to fixedly adjust the circumference of the headset body.

[0023] According to still further features in the described preferred embodiments, the adjustment mechanism is rigid or at least semi-rigid.

[0024] According to still further features in the described preferred embodiments, the frame includes first and second bi-lateral size adjustment mechanisms adapted to adjust the circumference of the headset body, the first adjustment mechanism connecting the side components to the front section, and the second adjustment mechanism connecting the side components to the rear section.

[0025] According to still further features in the described preferred embodiments, the first and second adjustment mechanisms are adapted to enable adjustment of the circumference of the headset body while a circumferential position of the side components remains fixed.

[0026] According to still further features in the described preferred embodiments, the frame is adapted such that along at least 30%, at least 40%, at least 50%, or at least 60% of a length of the circumference, the frame is substantially non-elastic.

[0027] According to still further features in the described preferred embodiments, the headset body is adapted to juxtapose a contact surface of an electrical device opposite or against the skin surface, the elastic arrangement adapted to radially urge the electrical device towards the skin surface such that a contact surface of the electrical device makes physical contact with the skin surface; the elastic arrangement adapted such that for various degrees of tensioning of the elastic arrangement, a circumferential position of the electrical device is fixed in a unique position.

[0028] According to still further features in the described preferred embodiments, the electrical device in-

cludes a sensor adapted to sense a body parameter associated with the head of the user.

[0029] According to still further features in the described preferred embodiments, the water-absorbent layer of the electrode pad includes at least one material selected from the group consisting of a non-woven fabric, felt or sponge.

[0030] According to still further features in the described preferred embodiments, the electrically conductive layer has, on a second face, distal to the water-absorbent layer, an electrically conductive layer having a higher electrical conductivity than the bulk of the electrically conductive layer, this highly conductive layer typically being an electrically conductive paint, preferably disposed in a mesh pattern.

[0031] According to still further features in the described preferred embodiments, the water-absorbent layer and the electrically conductive layer having the layer of electrically conductive paint form an integral structure.

[0032] According to still further features in the described preferred embodiments, the conductive carbon film or carbon foil has a resistivity of 1-180 ohm/square or 30-100 ohm/square.

[0033] According to still further features in the described preferred embodiments, the conductive carbon film or carbon foil has a thickness within a range of 30-1500 microns or 50-200 microns.

[0034] According to still further features in the described preferred embodiments, on the rim of the electrode base are circumferentially disposed a plurality of sealing fingers containing a volume, the sealing fingers adapted such that, when the rim is urged against the skin surface, the plurality of sealing fingers substantially seal between the volume and a volume external to the sealing fingers.

[0035] According to still further features in the described preferred embodiments, the rim includes, or consists essentially of, a circumferentially disposed plurality of sealing fingers, the sealing fingers adapted such that, when pressure is exerted, in generally perpendicular fashion with respect to the electrode base floor, or to the skin surface, the plurality of sealing fingers substantially seal between the cavity and a volume external to the rim.

[0036] According to still further features in the described preferred embodiments, the ratio A/L of the electrode arrangement is at least 0.2mm, at least 0.5mm, at least 0.7mm, at least 1mm, at least 1.5mm, or at least 1.7mm.

[0037] According to still further features in the described preferred embodiments, the length (L) is at least 12mm, at least 15mm, at least 18mm, or at least 20mm.

[0038] According to still further features in the described preferred embodiments, the electrode arrangement further includes an electrode pad.

[0039] According to still further features in the described preferred embodiments, an inner surface of the flexible circumferential wall has a radial curvature, and a

radial distance between an inner surface of the rim, and a most radially inward point of the inner surface of the wall, is at least 1mm, at least 3mm, at least 5mm, or at least 10mm.

[0040] According to still further features in the described preferred embodiments, this radial distance is within a range of 1 to 15mm, 2mm to 12mm, 2mm to 10mm or 2mm to 7mm.

[0041] According to still further features in the described preferred embodiments, an outer surface of the flexible circumferential wall has a radial curvature, and wherein a length of the curvature of the outer surface is at least 1mm, at least 2mm, at least 3mm or at least 5mm.

[0042] According to still further features in the described preferred embodiments, a length of the curvature of this outer surface is within a range of 1mm to 15mm, 2mm to 10mm or 3mm to 8mm.

[0043] According to still further features in the described preferred embodiments, the electrode arrangement further includes a pressuring arrangement, mechanically associated with the electrode base, and adapted to deliver the pressure against the electrode base, generally perpendicular to the rim.

[0044] According to still further features in the described preferred embodiments, the electrical device includes a transmitting arrangement adapted to transmit a signal from the sensor.

[0045] According to still further features in the described preferred embodiments, the electrode base housing includes a flexible bellows-type member.

[0046] According to still further features in the described preferred embodiments, the electrode base housing includes a liquid trapping and storing arrangement. WO2012079778 discloses a headband for use in neurostimulation made at least partly of elastic or stretch material.

BRIEF DESCRIPTION OF THE FIGURES

[0047] The invention is herein described, by way of example only, with reference to the accompanying drawings. With specific reference now to the drawings in detail, it is stressed that the particulars shown are by way of example and for purposes of illustrative discussion of the preferred embodiments of the present invention only, and are presented in the cause of providing what is believed to be the most useful and readily understood description of the principles and conceptual aspects of the invention. In this regard, no attempt is made to show structural details of the invention in more detail than is necessary for a fundamental understanding of the invention, the description taken with the drawings making apparent to those skilled in the art how the several forms of the invention may be embodied in practice. Throughout the drawings, like-referenced characters are used to designate like functionalities, but not necessarily identical elements.

[0048] In the drawings:

Figures 1 and 1A provide perspective views of one embodiment of the inventive headset, positioned on a head of a user;

Figure 2 is a perspective view of one embodiment of the inventive headset;

Figures 3 and 4 respectively provide a side view of inventive headsets, positioned on a head of a user;

Figure 5 is a side view of a portion of an inventive headset having a bifurcated posterior elastic member for improved headset stability;

Figure 6 is a perspective view of an inventive headset having a posterior elastic member devoid of electrodes;

Figures 7 and 7A provide perspective views of an inventive electrode base arrangement, and an elastic member for housing this arrangement, according to one embodiment of the present invention;

Figure 8 provides a perspective view of an inventive electrode base arrangement, according to a particular embodiment of the present invention;

Figure 8A provides a perspective view of the elastic member shown in Figure 7A with a cross section at a middle portion thereof;

Figure 9 is a cross-sectional view of the electrode base of Figure 7, coupled inside the elastic member of Figure 7A;

Figure 10 provides a perspective view of the inventive structure shown in Figure 9;

Figures 11A-11C illustrate an inventive, adjustable electrode base arrangement for adjusting the distance between adjacent electrode base housings, and three different positionings of those electrode base housings;

Figure 11D provides a perspective view of an elastic member for housing the adjustable electrode base arrangement shown in Figures 11A-11C;

Figures 12 and 13 illustrate an adjustable electrode base housing arrangement, and an elastic member for housing this arrangement, according to one embodiment of the present invention;

Figure 14 is a cross-sectional view of an electrode pad disposed on an electrode base;

Figures 15A and 15B provide perspective views of an electrode base with (Figure 15A) and without (Figure 15B) a multi-layered electrode pad, according to the present invention;

Figures 15C and Figure 15D provide cross-sectional and bottom views of this multi-layered electrode pad;

Figures 16A, 17A, 18A, 19A, and 20A provide cross-sectional views of an electrode base assembly, in which a particular electrode pad structure is coupled to an electrode base housing, according to various embodiments of the present invention;

Figures 16B, 17B, 18B, 19B, and 20B provide cross-sectional views of each respective electrode pad shown in Figures 16A, 17A, 18A, 19A, and 20A;

Figure 21 provides a perspective view of a spring-mounted electrode base housing containing an elec-

trode pad;

Figures 21A and 21B provide perspective and cross-sectional views, respectively of an electrode pad and bellows-type electrode base housing, according to an embodiment of the present invention;

Figures 21C and 21D provide perspective and cross-sectional views, respectively of an electrode pad and collapsing electrode base housing, according to an embodiment of the present invention;

Figure 22 is a perspective view of an inventive electrode base housing having a circumferential sealing rim;

Figure 23 provides a cross-sectional view of the electrode base housing shown in Figure 22, the housing having an electrode pad disposed therein;

Figure 24 provides a cross-sectional view of the electrode base housing and electrode pad shown in Figure 22, the electrode pad being urged against a skin surface;

Figure 25 is a cross-sectional view of an electrode base in which the wall geometry is defined;

Figure 25A provides a cross-sectional view of an inventive electrode base housing containing an electrode pad, the electrode pad being urged against a skin surface;

Figure 25B provides a cross-sectional view of the housing and pad arrangement of Figure 25A in a relaxed mode, and in which the wall geometry is defined;

Figure 25C provides a perspective view of an inventive electrode base housing containing an electrode pad, the housing containing a plurality of closely spaced sealing fingers circumferentially enveloping the electrode pad;

Figure 25D provides a cross-sectional view of the housing and pad arrangement of Figure 25C;

Figure 25E provides a top view of the housing and pad arrangement of Figure 25C;

Figure 25F provides a cross-sectional view of an inventive housing and pad arrangement in which the housing wall curvature is adapted to trap excess fluid;

Figure 25G provides a schematic perspective cross-sectional view of one embodiment of the inventive headset, positioned on a head of a user, and Figure 25H provides magnified views of the electrode base housings urged against the head;

Figure 26 is a perspective view of a flexible, comb-like member disposed above an electrode base housing, according to embodiments of the invention;

Figure 27 is a perspective rear view of a donned headset in which the flexible, comb-like member of Figure 26 protrudes above the circumferential band of the headset;

Figure 28 is a perspective anterior view of a donned headset, the headset configured, and the front electrodes adapted and positioned to stimulate specific nerve branches in the forehead region, according to

embodiments of the invention;

Figure 29 provides the dimensions of an inventive electrode configured to selectively stimulate nerve branches in the supraorbital region;

Figure 30 is a perspective rear view of a donned headset, the headset configured, and the rear electrodes adapted and positioned to stimulate specific nerve branches in the occipital nerve region, according to embodiments of the invention;

Figure 31 provides a side perspective view of a bilateral member of an inventive headset, according to one embodiment of the invention;

Figure 32 is a perspective view of a donned, inventive headset;

Figure 33 is a perspective anterior view of a donned, inventive headset having a nose bridge support member;

Figure 34 is a perspective view of a donned, inventive headset having associated eyeglasses;

Figure 35 is a perspective view of an inventive headset having associated earphones; and

Figure 36 provides a perspective view of a donned, inventive headset adapted to communicate with a remote control unit, mobile phone, and computer

DETAILED DESCRIPTION

[0049] Device and methods are described herein that include a headset with one or more integrated electrodes for applying electrical stimulation to peripheral nerves, cranial nerves and brain regions. The inventive headset is a head mounted construction that can be served as a platform for applying electrical stimulation to treat various conditions such as migraine and tension headaches, fibromyalgia, depression, post-traumatic stress syndrome, anxiety, obsessive compulsive disorder (OCD), insomnia, epilepsy, attention deficit hyperactivity disorder (ADHD), Parkinson's disease, Alzheimer's disease, multiple sclerosis, and stroke. The inventive headset may facilitate motor and cognitive learning and may induce relaxation. The inventive headset may also serve as a platform for various sensors, in order to detect and/or assess various conditions.

[0050] The stimulation electrodes and the quality of its contact with the scalp are a fundamental aspect in the functionality of the invented apparatus. Ensuring optimal conductivity between the electrodes and the scalp is essential for proper transfer of the electrical current to the target tissues, which is the basis for an effective treatment. Improper conductivity may result in failure of the therapy, unpleasant sensation and even skin irritation due to "hot spots" of high current density. The inventors have also found that non-invasive application of electrical current to the head region, no matter which indication it is applied for, may pose numerous challenges including stimulation in the presence of hair, high level of sensory sensitivity of the scalp and forehead, the criticality of robust contact and electrical conductivity between the elec-

trodes and the scalp, despite variations in head size and contours, and accurate placement of the stimulating electrodes above the target nerve and brain regions.

[0051] Several aspects of the present invention relate to features that are aimed at ensuring that the electrical current is properly delivered from the electrode to the target tissues and for treating and assessing the head region in an effective and comfortable manner.

[0052] With reference now to the drawings, **Figure 1** and **Figure 1A** provide perspective views of one embodiment of the invented headset system **10**, donned on head **5**. In one embodiment, headset **10** may be configured to include a circumferential frame ("headset body") that may include a posterior elastic member **30**, an anterior elastic member **40** and bilateral semi rigid and preferably rigid members **50a**. Posterior elastic member **30** may be configured to be coupled to bilateral members **50a** at connection point **8** and **16**. Anterior member **40** may be configured to be coupled to bilateral members **50a** at connection points **14** and **18**. Anterior member **40** may be configured to encompass the forehead region **12**. Posterior elastic member **30** may be configured to encompass the occiput region **11**. Middle bilateral semi-rigid members **50a** may be configured to be positioned behind and above ears **16**.

[0053] **Figure 2** illustrates a perspective view of one embodiment of the invented headset system **10**. Headset **10** may be configured to include an elastic posterior member **30**, elastic anterior member **40** and rigid and preferably semi-rigid bilateral members **50a**. Posterior member **30** may be configured to connect to middle bilateral members **50a** by size adjustment mechanisms **32a** and **32b**, configured to be located behind the ears. Anterior member **40** may be configured to connect to bilateral middle members **50a** by size adjustment mechanisms **42a** and **42b**, configured to be located at both sides of the head, anterior to the ears.

[0054] The adjustment of headset **10** to various head sizes may be performed by bilateral anterior adjustment mechanisms **32a** and **32b** and posterior bilateral adjustment mechanisms **42a** and **42b**. Pulling or pushing elastic members **30** and **40** away from or toward middle bilateral members **50a**, allows increasing or decreasing the size/circumference of headset **10**. According to certain embodiment, middle bilateral members **50a** may be configured to be flexible in order to self-align to a wide variety of head contours.

[0055] The mechanism for adjustment of headset **10** to various head sizes may include solely bilateral anterior adjustment mechanisms **32a** and **32b**, or bilateral posterior adjustment mechanisms **42a** and **42b**.

[0056] In some embodiments, having both anterior adjustment mechanisms **32a** and **32b** and posterior adjustment mechanisms **42a** and **42b** may enable better adjustment of the headset while maintaining its symmetrical placement on the head. Furthermore, it may enable adjustment of the headset size while maintaining the proper placement of bilateral members **50a** behind the corre-

sponding ears.

[0057] Posterior member **30** and anterior member **40** may be configured to contain electrode bases (also called electrode system) **60** and **70** respectively and when stretched, are configured to apply radial force on electrode base housing **150** toward the scalp in order to ensure electrical coupling between electrodes pads **56a** and the skin surface, while minimizing undesired pressure of the headset against the scalp at areas that does not hold the electrodes.

[0058] Middle bilateral member **50a** may be configured to contain electronic circuit **52b**, which may be configured to be electrically coupled by conductive wires **54** to battery **52a** and to electrodes units **60** and **70**.

[0059] Electronic circuit **56b** may be configured to include a stimulation circuit, a microprocessor, a charging circuit and a user interface.

[0060] The stimulation circuit may be configured to produce biphasic, charged balanced electrical pulses, mono-phasic electrical pulses, and/or direct current stimulation.

[0061] According to still further features of the described preferred embodiments, the stimulation circuit may be configured to produce electrical stimulation within an intensity range of 0-80mA, 0-40mA, 0-20m, or 0-15mA.

[0062] According to still further features of the described preferred embodiments, the stimulation circuit may be configured to produce stimulation pulses with a duration of 10-600 μ sec, 50-500 μ sec, 100-500 μ sec, 100-450 μ sec, 150-400 μ sec or 150-450 μ sec.

[0063] According to still further features of the described preferred embodiments, the stimulation circuit may be configured to produce stimulation pulses at a frequency of 1-500Hz, 10-300Hz, 10-250Hz, 20-180Hz or 30-180Hz.

[0064] According to still further features of the described preferred embodiments, headset **10** may be configured to connect to an external electronic and stimulation circuit and thereby to transfer electrical current from the external stimulator to the headset electrodes. Headset **10** may be configured to connect to at least one external electrode that may be located at various areas of the body. Headset **10** may be configured to connect to an external electronic circuit and processor in order to transfer signals from its on board sensors to the external processor.

[0065] Battery **52a** may be recharged by plugging a charger to charging port **770** located on member **50a**. Bilateral member **50a** may also be configured to include user controls and interface **750**. In some embodiments, both bilateral members may be configured to include a user interface **750**. In some embodiments, other parts of inventive headset **10**, such as anterior member **40** or posterior member **30**, may be configured to include user interface **750**.

[0066] In some embodiments of the present invention, elastic members **30** and **40** of headset **10** may be con-

figured, in a stretched mode, to transfer radial force to electrode base housing **150** in order to ensure contact between electrode pads **56a** and the skin surface, while minimizing undesired pressure of the headset against the scalp at areas that does not hold the electrodes.

[0067] **Figure 3** is an illustration of a side view of headset **10**. In some embodiments, headset **10** may be configured to be positioned at a higher location on the head while maintaining its various properties including accurate placement, adjustment to various head sizes and electrode attachment. Positioning headset **10** at a higher location on the head may enable stimulation of other nerves and brain regions, and may also enable positioning of various sensors, such as for example EEG sensors, at higher locations over the head.

[0068] According to another aspect of the present invention, headset **10** may be configured to include wider elastic members **40** and **30**, with bilateral member **56a** that may be adapted to connect to wider members **40** and **30**. Wider members **40** and **30** may enable integration of larger electrodes within headset **10** in order to stimulate larger areas, such as for stimulation of various brain regions.

[0069] **Figure 4** provides a side view of headset **10**, having additional semi-rigid and preferably elastic member **590**, configured to be coupled perpendicularly to bilateral member **56a** and adapted to be disposed between bilateral members **56a** and to encompass the top of the head. Elastic member **590** may enable stimulation and positioning of electrodes and sensors at higher locations on the head.

[0070] **Figure 5** provides a side view of headset **10**, configured to include a bifurcated posterior elastic member **30** in order to increase the stability of headset **10** over the occiput region.

[0071] **Figure 6** is a perspective view of headset **10**, where posterior elastic member **30** does not hold electrodes and its main or sole function is to stabilize headset **10** on the head.

[0072] When required, anterior elastic member **40** may be configured to not include electrodes while posterior member **30** includes the electrodes.

[0073] **Figure 7** provides a perspective view of an inventive electrode base or base arrangement **60**; **Figure 7A** provides a perspective view of an elastic member **30** for housing arrangement **60**, according to one embodiment of the present invention.

[0074] With reference to **Figures 7** and **7A**, elastic member **30** is configured to be at least partially hollow in order to contain electrode base **60** and electrical conducting wires **54**, as well as to assist in preserving a stable three-dimensional configuration of the headset while maintaining a low modulus of elasticity. Elastic member **30** may be configured to include at least one opening **82** on an interior side (facing the skin surface). Electrode base **60** may be configured to include at least one housing **150**. In one embodiment, housing **150** is configured to be coupled to elongated flexible member **64**. Electrode

base **60** may be configured to be physically coupled inside elastic member **30**, such that a flexible connecting band **84** is coupled to elastic member **30** at coupling portion **64**.

[0075] Elastic member **30** may have a lower modulus of elasticity above electrode base housing **150**, compared to a higher modulus of elasticity in its other areas. A lower modulus may be achieved in areas of member **30** that are parallel to the bottom surface of housing **150**, due to opening **82** and, for example, due to configuring the external surface of member **30**, in the area parallel to openings **82**, to be thinner than its other areas. Thus, when headset **10** is donned, a focal radial force is applied by member **30** on electrode base housing **150** toward the scalp. In contrast, other areas of elastic member **30** may be configured to have a higher modulus of elasticity and therefore the radial force toward the scalp at these areas is minimized in order to prevent excess pressure where not needed. The areas which are configured to have a higher modulus of elasticity may also assist in maintaining a stable three-dimensional structure of member **30** and of headset **10**, thereby facilitating easier donning and accurate placement of the electrodes.

[0076] **Figure 8** and **Figure 8A** provide a perspective view of electrode base **60** and a cross-sectional view of elastic member **30** (shown in **Figure 7A**), respectively. In order to enable coupling to electrode base **60**, elastic member **30** may be configured to include protrusions **96a** and **96b**. Electrode base **60** may be configured to include holes **98a** and **98b** in flexible connecting band **84**. In order to physically couple electrode base **60** and elastic member **30**, electrode base **60** may be inserted into elastic member **30**, such that protrusions **96a** and **96b** may be snapped into holes **98a** and **98b**. The physical coupling may include other mechanisms. For example, flexible member **68** may be glued at its coupling portion **64** to flexible member **30**.

[0077] **Figure 9** provides a cross-sectional view of electrode base **60**, coupled inside elastic member **30**. Electrode base **60** may be integrated inside headset member **30** where flexible connecting band **84** may be physically coupled to elastic member **30** at coupling portion **64** only, and therefore, when the headset is donned, member **30** may be stretched to elicit radial force on electrode base housing **150** and electrode pads **56a** toward the scalp, without being constrained by electrode system **60**. This arrangement also ensures that when headset member **30** is stretched, the pre-determined distance between electrode base housing **150** is maintained.

[0078] **Figure 10** illustrates a portion of headset member **30** according to one embodiment. Electrode system **60** (partially hidden) is integrated inside member **30** while only electrode base housing **150** and electrode pads **56a** protrude through openings **82a** and **82b** of elastic member **30**. Flexible connecting band **84** and coupling portion **64** are illustrated by dotted lines. Openings **82a** and **82b** may extend beyond the medial edge of electrode base housings **150** in order to allow openings **82a** and **82b** to

extend laterally when member **30** is stretched and therefore the extension of member **30** may not be constrained.

[0079] **Figures 11A-11C** are perspective views of an inventive electrode base arrangement in which the distance between adjacent electrode base housings **150**, may be pre-set. **Figures 11A-11C** provide three different pre-set positionings **60A-60C** of those electrode base housings. **Figure 11D** provides a perspective view of an elastic member for housing the adjustable electrode base arrangement shown in **Figures 11A-11C**.

[0080] According to certain features of the described preferred embodiments, the position of electrode base housing **150** may be adjusted to fit various morphological and anthropometric variables of certain users. According to one embodiment, electrode base units **60a**, **60b** and **60c** may be configured to have a variable distance between its electrode base housing **150**. It may be configured to be reversibly coupled to elastic member **30** by holes **64** of the electrode system and protrusions **96a** and **96b** (both hidden) on elastic member **30**. According to certain features of the described preferred embodiments, coupling of electrode base units **60a**, **60b** and **60c** may also be performed by other coupling mechanisms.

[0081] **Figure 12** and **Figure 13** illustrate a mechanism for adjustment of the placement of electrode base housing **150** according to further features of the described preferred embodiment.

[0082] **Figure 12** illustrates an interior view of elastic member **30** according to one embodiment, where flexible connecting band **84** is coupled to member **30** by protrusions **96a** and **96b** (both hidden) elongating from member **30** and snapped into holes in flexible connecting band **84**. The mechanical coupling of flexible connecting band **84** and elastic member **30** may be performed by other mechanisms such as other snap connectors or by gluing. According to one embodiment, flexible connecting band **84** is configured to include holes **98** at a distance within a range of 0.5-5cm between each hole, and more typically, within 0.5-3cm, 0.5-2cm, or 0.5-1cm.

[0083] **Figure 13** illustrates a bottom view of a portion of electrode base **60**. According to one embodiment, electrode base housing **150** may be configured to include protrusions **92a** and **92b** arising from its bottom surface. Protrusions **92a** and **92b** are configured to be snapped into any of the holes **98** in flexible connecting band **84**. The placement of electrode base housing **60** may be adjusted by snapping protrusions **92a** and **92b** into other holes **98** in flexible connecting band **84**.

[0084] **Figure 14** is a cross section of an electrode pad **56a** disposed in an electrode base **60**. Electrode base **60** may be configured to be physically coupled to the headset by elongated flexible connecting band **84** and may be electrically coupled to the headset electrical circuit by conductive wire **158**. It may be configured to include at least one electrode base housing **150** which include elevated circumferential walls that are surrounding a "floor", thereby creating a cavity adapted to receive at

least one conductive electrode pad **56a**. According to certain embodiment, electrode base housing **150** is preferably made of a flexible material such as silicon or thermoplastic polyurethane (TPU).

[0085] Electrode base housing **150** may be configured to include an electrically conductive material **154** disposed at least partially above, or within electrode base housing **150** floor. The conductive layer is adapted to be electrically coupled to an electric circuit by electrical conductor **158**.

[0086] Conductive layer **154** may be configured to include material such as stainless steel, copper, brass, silicone carbon, conductive silver paint print, stainless mesh or other conducting elements. When conductive layer **154** is made of carbon, an additional layer of conductive paint may be printed on its bottom surface. Such a conductive paint layer may improve the homogeneity of current distribution across the surface of conductive layer **154** and thereby improve the homogeneity of current distribution on the surface of electrode pad **56a**. Conductive layer **154** may preferably be flexible in order to not compromise the overall flexibility of electrode base **60** and thereby to ensure its alignment with various head contours. In certain embodiments, conductive layer **154** may be limited in its area and may be configured to cover only a portion of the floor surface of electrode base housing **150**. In such a case, conductive layer **154** may not be flexible and may be made of various electrically conductive materials known to those of skill in the art. Conductive layer **154** may be configured to be electrically coupled to an electrical conductor (cable or wire) **158** and thereby be electrically connected to the headset electrical circuit.

[0087] Electrode pad **56a** may be configured to be releasably coupled (physically and electrically) to electrode base housing **150**. Electrode pad **56a** may include at least a portion of water or other liquid absorbing material such as non-woven fabric, felt or sponge. The user may soak electrode pad **56a** with water or other liquid before use. When coupled to housing **150**, electrode pad **56a** is configured to be in electrical contact with conductive layer **154**. When the headset is donned, pad **56a** is urged toward the skin surface and may create electrical contact with the skin surface (skin surface including the scalp) in order to transfer electrical current to the skin surface.

[0088] Electrode pad **56a** and other electrodes associated with the headset may be configured to receive (sense) electrical current or other bio-signals from the skin surface, such as for example electroencephalogram (EEG) and either transfer it via the headset circuit to an electronic circuit that includes a microprocessor or transmit it wirelessly to a remote unit.

[0089] Electrode pad **56a** may be disposable and may be conveniently replaced by the user.

[0090] Electrode pad **56a** may be configured to include a peripheral edge **156** that is thinner than the central area of pad **56a**. Peripheral edge **156** can be made by various manufacturing process such as ultrasonic welding, RF

welding or heat compression. By inserting the thin edge **156** into a corresponding groove **152** in housing **150**, electrode pad **56a** can be reversibly physically coupled to housing **150** and electrically coupled to conductive layer **154**.

[0091] Electrode pad **56a** may be configured to have larger area compared to housing **150**. It can therefore be squeezed into housing **150** in order to be reversibly (physically and electrically) coupled to housing **150**.

[0092] Electrode base housing **150** may be configured to include a conducting mechanical snap connector configured to be both physically and electrically reversibly coupled to a corresponding connector attached to electrode pad **56a**.

[0093] Perspective views of an electrode base **60** with and without an inventive, multi-layered electrode pad **56a** are provided in **Figure 15A** and **Figure 15B**. **Figures 15C** and **Figure 15D** provide cross-sectional and bottom views of multi-layered electrode pad **56a**. Multi-layered electrode pad **56a** may include water absorbent layer **254** and a flexible electrically conductive layer **258**, preferably made of a carbon foil. The two layers may be attached or directly attached. Various manufacturing processes may be used, including heat welding, RF welding, ultrasonic welding, gluing or sewing. In order to reduce current density at the edges of liquid absorbing layer **254**, conductive layer **258** may be configured to have a smaller area or "footprint" than layer **254**. Consequently, the current density at the edges of layer **254** (which has a lower electrical conductivity with respect to layer **258**) will be reduced. Conductive layer **258** may further include a thin electrically conductive layer **255** of conductive paint, which may be printed in a "mesh" pattern and may be configured to cover only the central portion of layer **258**. Conductive layer **255** may preferably be printed on the bottom surface of layer **258** and may be configured to face conductive layer **154** of electrode base housing **150** so as to be electrically coupled when multi-layered electrode pad **56a** is attached to electrode base housing **150**. Conductive print layer **255** may be configured to have a higher electrical conductivity compared to layer **258**, such that current dispersion over layer **258** is improved while reducing current density at the edges of layer **258** (which does not include layer **255**).

[0094] **Figures 16A, 17A, 18A, 19A, and 20A** provide cross-sectional views of an electrode base assembly, in which a particular electrode pad structure is coupled to an electrode base housing, according to various embodiments of the present invention. **Figures 16B, 17B, 18B, 19B, and 20B** provide cross-sectional views of each respective electrode pad shown in **Figures 16A, 17A, 18A, 19A, and 20A**.

[0095] With reference now to **Figures 16A and 16B**, electrode pad **56a** may include a liquid absorbing layer **254** and a "hook" (e.g., Velcro®) fastening layer **252**. Both layers may be attached by various manufacturing process such as heat welding, RF welding, ultrasonic welding, gluing or sewing. According to one embodiment,

electrode base housing **150** may be configured to be coupled to a "loop" (e.g., Velcro®) fastening layer **256**, disposed in a groove in the internal perimeter of elastic housing **150**. According to one embodiment, in order to releasably couple electrode pad **56a** to electrode base housing **150**, the user may position electrode pad **56a** inside housing **150** and thereby the hook layer **252** of electrode pad **56a** and the loop layer **256** may be reversibly attached, ensuring contact between conducting layer **154** and liquid absorbing layer **254**.

[0096] With reference now to **Figures 17A and 17B**, electrode pad **56a** may include three layers: a liquid absorbing layer **254**, a flexible conductive layer **258**, preferably made of a flexible carbon layer and a "hook" (e.g., Velcro®) fastening layer **252**, coupled to at least portion of the bottom perimeter of electrode pad **56a**. The three layers may be attached by various manufacturing process such as heat welding, RF welding, ultrasonic welding, gluing or sewing. According to one embodiment, electrode base housing **150** may be configured to be coupled to a "loop" (e.g., Velcro®) fastening layer **256**, disposed in a groove in the internal perimeter of housing **150**. According to one embodiment, in order to releasably couple electrode pad **56a** to electrode base housing **150**, the user may position electrode pad **56a** inside housing **150** and thereby hook layer **252** of electrode pad **56a** and loop layer **256** may be reversibly coupled, ensuring contact between conducting layer **154** of electrode base housing **150** and conducting layer **258** of electrode pad **56a**.

[0097] Conductive layer **258** may be configured to include a layer of conductive paint that may preferably be printed on its bottom surface configured to face conductive layer **154** of electrode base housing **150**. The conductive paint layer may improve the current distribution across conducting layer **258** and liquid absorbing layer **254** and thereby may improve current distribution at the contacting skin surface.

[0098] Electrode pad **56a** may be configured to include a conducting "male" connector, such as a "male" snap connector, that may be physically and electrically coupled to electrode pad **56a** and can be reversibly connected physically and mechanically to a corresponding "female" snap connector in electrode base housing **150**, which may be electrically coupled to the headset electrical circuit.

[0099] With reference now to **Figures 18A and 18B**, electrode pad **56a** may include three layers: a liquid absorbing layer **254**, a flexible conductive layer **258**, preferably made of a flexible carbon layer and an adhesive hydrogel layer **302**. Liquid absorbing layer **254** and flexible conductive layer **258** can be attached by various manufacturing process such as heat welding, RF welding, ultrasonic welding, gluing or sewing. Adhesive hydrogel layer **302** may be adhered to flexible conductive layer **258** by the adhesive properties of the hydrogel layer. According to one embodiment, in order to releasably couple electrode pad **56a** to electrode base housing **150**,

the user may position electrode pad **56a** inside housing **150** and thereby the adhesive hydrogel layer **302** of electrode pad **56a** and conductive layer **154** may be reversibly coupled, ensuring stable physical and electrical coupling of electrode base housing **150** and electrode pad **56a**.

[0100] With reference now to **Figures 19A and 19B**, electrode pad **56a** may be configured to include a liquid absorbing layer **254**, a flexible conductive layer **258**, (e.g., made of a flexible carbon layer), and a double adhesive layer **308**, coupled to at least portion of the bottom perimeter of electrode pad **56a** which is configured to face conductive layer **154** of housing **150**. Liquid absorbing layer **254** and flexible conductive layer **258** can be attached by various manufacturing process such as heat welding, RF welding, ultrasonic welding, gluing or sewing. Double side adhesive layer **308** may be adhered to flexible conductive layer **258** by its adhesive properties. According to one embodiment, in order to releasably couple electrode pad **56a** to electrode base housing **150**, the user may position electrode pad **56a** inside housing **150** and thereby the double side adhesive layer **308** of electrode pad **56a** and housing **150** may be reversibly coupled, ensuring stable physical and electrical coupling of electrode base housing **150** and electrode pad **56a**.

[0101] With reference now to **Figures 20A and 20B**, electrode pad **56a** may be configured to include a liquid absorbing layer **254** and a flexible conductive layer **258**, preferably made of flexible carbon. Liquid absorbing layer **254** and flexible conductive layer **258** can be attached by various manufacturing process such as heat welding, RF welding, ultrasonic welding, gluing or sewing. Electrode pad **56a** may include a peripheral edge **312** that is thinner than the central area of liquid absorbing layer **254**. The thinner edge **312** can be made by certain manufacturing process such as ultrasonic welding, RF welding or heat compression. The user can reversibly couple electrode pad **56a** to electrode base housing **150** by pressing electrode pad **56a** into housing **150**, until the thinner edge **312** is "snapped" into the corresponding groove **310** in housing **150**. In this position, conductive layer **258** of electrode pad **56a** and conductive layer **154** of electrode base housing **150** are attached and therefore when the headset is donned, electrical current can be transferred from conductive layer **154** to conductive layer **258** and to liquid absorbing layer **254** and then to the skin surface.

[0102] **Figure 21** illustrates a perspective view of an electrode base **60**. According to certain features of the described preferred embodiments electrode base **60** may be configured to include at least one spring mechanism **320** which may be configured to be physically coupled at one side to flexible member **80** and at its other side to electrode base housing **150**. Spring mechanism **320** may be configured to provide "self-adjustment" capabilities for electrode base housing **150**, so that when the headset is donned, spring mechanism **320** is compressed or expanded according to the force applied on electrode base housing **150** by the headset and the coun-

ter force applied by the head. In certain embodiments spring mechanism **320** may include an elastic mechanism or a sponge instead or in addition to a metal or plastic spring.

[0103] **Figures 21A and 21B** provide perspective and cross-sectional views, respectively of an electrode pad **56a** and a bellows-type electrode base housing **150**, according to an embodiment of the present invention. Electrode base housing **150** may be configured to include a flexible bellows carrier **321** that may be configured to be physically coupled to, or be extended from, the bottom of electrode base housing **150**. Flexible bellows carrier **321** may be configured to provide "self-adjustment" capabilities for electrode base housing **150**, such that when the headset is donned, bellows carrier **321** is compressed or expanded according to the force applied on electrode base housing **150** by the headset and the counter force applied by the head.

[0104] With reference to **Figure 21B**, flexible bellows carrier **321** may be configured to have the following dimensions:

A - The height of each crease of the bellows. **A** may be within a range of 1mm-8mm, 2mm-6mm, or 2mm-4mm;

B - The angle of each crease of the bellows. **B** may be within a range of 40°- 90°, 50°- 80°, or 60°- 80°;

C - The thickness of the wall of the bellows. **C** may be within a range of 0.3mm-3mm, 0.4mm-2mm, or 0.5mm-1.5mm.

[0105] **Figures 21C and 21D** provide perspective and cross-sectional views, respectively of an electrode pad **56a** and electrode base housing **150** having a conical shaped bellows carrier **321**, according to embodiments of the present invention. Conical shaped flexible bellows carrier **321** may be configured to be physically coupled to, or extended from, the bottom of electrode base housing **150**. Bellows carrier **321** may be configured to provide "self-adjustment" capabilities for electrode base housing **150**, such that when the headset is donned, bellows carrier **321** may be compressed or expanded according to the force applied on electrode base housing **150** by the headset and the counter force applied by the head. Bellows carrier **321** may be configured to reversibly and repeatedly collapse to less than 50%, less than 40%, less than 30%, or less than 20% of its initial, relaxed height. This may enable appreciably improved alignment of the headset and electrode pad **56a** against the head.

[0106] **Figure 22** is a perspective view of electrode base housing **150**. According to one embodiment, electrode base housing **150** is configured to include a circumferential sealing rim **360**. Stimulation in the presence of hair, such as when attempting to non-invasively stimulate various areas of the head, presents a challenge, since the hair creates a high impedance layer between the superficial electrodes and the skin. Solid adhesive hydrogel is the most common conductive medium used in electri-

cal stimulation electrodes. However, hydrogel may not be particularly suitable for use in the presence of hair, due to poor penetration of the hair layer. Other conductive media, such as semi-liquid conductive gel, may not be user-friendly, since it requires washing/cleaning the hair and the device after each session of use.

[0107] By contrast, tap water may be more suitable from a penetration standpoint, since it can pass through the hair layers and does not leave residue. Furthermore, unlike a conductive gel, tap water is commonly available. The inventors have found that in order to ensure the required conductivity and substantially even current distribution, a substantial layer of water should be maintained against the scalp during the treatment and dehydration should be prevented, especially during prolonged treatment sessions. Prevention of electrode dehydration may be required in areas that do not include hair, such as the forehead. Thus, the electrode pads and arrangements of the present invention are typically devoid of, or substantially devoid of, hydrogel.

[0108] **Figure 23** provides a cross-sectional view of electrode base housing **150** with electrode pad **56a** inserted.

[0109] **Figure 24** is a cross-sectional view of electrode base housing **150** with electrode pad **56a** inserted, while urged against a skin surface **362**. The housing **150** may be adapted such that a pressure exerted against electrode base **60** (not shown) perpendicularly to the sealing rim **360** and towards a skin surface **362** of a user, urges sealing rim **360** against the skin surface to substantially seal the cavity created between sealing rim **360** and the skin surface **362** of the user and an ambient or external environment.

[0110] Sealing rim **360** may be made of flexible material such as TPU or silicon, and may be configured to have a modulus of elasticity that is sufficient to maintain a level of pressure against the scalp that provides the required sealing effect. However, an overly large modulus of elasticity may result in excessive pressure against the scalp. Sealing rim **360** may be sufficiently pliant to be self-aligning to various head contours. Sealing rim **360** may be configured to have a high drag coefficient, in order to assist in stabilizing the electrode in place against the scalp. Also, sealing rim **360** may be configured to prevent dehydration of the wetted pad and the water contained within the sealed space and thereby to enable effective and prolonged sessions of stimulation. Sealing rim **360** may be configured to be detachable from the electrode base when the stimulation electrode is placed in areas where sealing is not needed.

[0111] The headset may be configured to include sealing rims having various contours, to ensure proper sealing functionality at specific skin surfaces and locations. In order to reach the required sealing effect, sealing rim **360** may be configured to include material that inflates in the presence of water,.

[0112] Electrode base housing **150** with sealing rim **360** may be configured to be used in areas that do not

include hair such as the forehead or other areas of the body, for example, in order to prevent electrode pad dehydration.

[0113] Electrode base housing 150 with sealing rim 360 may be configured to include the following dimensions (see Figure 25):

[0114] The inner surface of the flexible circumferential wall of housing 150 has a radial curvature, wherein a radial distance (A) between an inner surface of rim 360 and a most radially inward point of the inner surface of the wall of housing 150, is in the range of 1 to 15mm, 2mm to 10mm, or 2mm to 7mm.

[0115] The outer surface of the flexible circumferential wall of housing 150 has a radial curvature, wherein the length (B) of the curvature is within a range of 1mm to 15mm, 2mm to 10mm, or 2mm to 8mm.

[0116] Figure 25A provides a cross-sectional view of an inventive electrode base housing 150 having a sealing rim 360 and containing an electrode pad 56a, the electrode pad being urged against a skin surface 362. The housing 150 may be adapted such that a pressure exerted against electrode base 60 (not shown) perpendicularly to the sealing rim 360 and towards a skin surface 362 of a user, urges sealing rim 360 against the skin surface to substantially seal the cavity created between sealing rim 360 and the skin surface 362 of the user and an ambient or external environment.

[0117] Sealing rim 360 may be made of flexible material such as TPU or silicon, and may be configured to have a modulus of elasticity that is sufficient to maintain a level of pressure against the scalp that provides the required sealing effect. However, an overly large modulus of elasticity may result in excessive pressure against the scalp.

[0118] According to certain embodiment the level of hardness of sealing rim 360 may be 20-50 Shore A, more preferably 20-40 Shore A, most preferably 30-40 Shore A.

[0119] According to certain embodiment the modulus of elasticity (E) of sealing rim 360 (at 100% strain) is 0.4MPa-3MPa, 0.5MPa-2MPa, or 0.5MPa-1.2MPa.

[0120] Sealing rim 360 may be configured to prevent dehydration of the wetted pad and the water contained within the sealed space and thereby to enable effective and prolonged sessions of stimulation.

[0121] Figure 25B provides a cross-sectional view of the housing 150, sealing rim 360 and pad 56a arrangement of Figure 25A in a relaxed mode, and in which the wall geometry is defined. Electrode base housing 150 with sealing rim 360 may be configured to have the following dimensions (see Figure 25B):

[0122] Sealing rim wall thickness (A) may be 0.3mm-3.0mm, 0.4mm-1.5mm, or 0.5mm-1mm.

[0123] Sealing rim curvature length (B) may be 1mm-10mm, 2mm-8mm, or 3mm-6mm.

[0124] Sealing rim curvature height (C) may be 1mm-10mm, 2mm-8mm, or 2mm-4mm.

[0125] Figure 25C provides a perspective view of an

inventive electrode base housing 150 containing an electrode pad 56a, the housing containing a plurality of closely spaced sealing fingers 361 circumferentially enveloping the electrode pad 56a. Housing 150 may be adapted such that a pressure exerted against electrode base 60 (not shown) perpendicularly to the sealing fingers 361 and towards a skin surface of a user, urges sealing fingers 361 against the skin surface to at least partially seal, or at least substantially seal, the cavity created between sealing fingers 361 and the skin surface of the user and an ambient or external environment.

[0126] Sealing fingers 361 may be made of flexible material such as TPU or silicon, and may be configured to have a modulus of elasticity that is sufficient to maintain a level of pressure against the scalp that provides the required sealing effect.

[0127] According to certain embodiment, sealing "fingers" 361 are configured to self-align to various surface/skin contours. The fluid surface tension prevents it from flowing between fingers 361 and thereby the fluid is kept around pad 56a.

[0128] Figure 25D provides a cross-sectional view of the arrangement of Figure 25C.

[0129] Figure 25E provides a top view of the arrangement of Figure 25C. Electrode base housing 150 with sealing fingers 361 may be configured to include the following dimensions (see Figures 25D and 25E):

[0130] The thickness (A) of a sealing finger 361 is preferably 0.3mm-1.5mm, more preferably 0.4mm-1.2mm, most preferably 0.5mm-1mm.

[0131] The angle (B) of a sealing finger 361 is preferably 20°-90°, more preferably 40°-80°, most preferably 60°-80°.

[0132] The width (C) of a sealing finger 361 is preferably 0.3mm-3mm, more preferably 0.4mm-2.5mm, most preferably 0.5mm-1.5mm.

[0133] The gap (D) between sealing fingers 361 is preferably 0.1mm-1.5mm, more preferably 0.2mm-0.1mm, most preferably 0.2mm-0.8mm.

[0134] Figure 25F provides a cross-sectional view of an inventive housing 150 and pad 56a arrangement in which a wall curvature 363 of housing 150 is adapted to trap and store excess fluid in the cavity 366 created between the inner wall curvature and pad 56a. When the headset is donned, pad 56a is urged against the head and may release some of its excess fluid into cavity 366. The fluid contained in cavity 366 may later be reabsorbed by pad 56a and released toward the skin surface.

[0135] Figure 25G provides a schematic perspective cross-sectional view of one embodiment of the inventive electrode base housings 150 positioned on a head 5 of a user and urged against the head, and Figure 25H provides magnified views of the electrode base housings 150 and sealing rims 360 urged against head 5.

[0136] Figure 26 is a perspective view of a flexible, comb-like ("hair clearing") member 376 disposed above an electrode base housing, according to embodiments of the invention. Member 376 may be configured to be

physically coupled to the headset above electrode base housing 150, and may be configured to include several elongated rigid and preferably semi-rigid members or teeth 378.

[0137] Figure 27 is a perspective rear view of a donned headset in which the flexible, comb-like member 376 protrudes above the circumferential band of headset 10. While the user dons headset 10 on his head 372, elongated members 378 may be configured to jut above the electrodes at areas that include hair, such as the back or sides of the head. Comb-like member 376 may be configured to enable simple donning of headset 10 while ensuring temporarily pushing away and clearing of hair layers under the electrodes so that only minimal amount of hair will remain between the electrodes and the skin. Flexible, comb-like member 376 may be configured to function like a comb, separating layers of hair 374 from the scalp while headset 10 with its electrodes is pushed upward by the user into an operating position on head 372, thereby ensuring the required electrical conductivity between the electrodes and the skin.

[0138] According to another features of the described preferred embodiments, member 376 may be configured to be detachable from headset 10 in order to enable its removal by the user, for example, in the case that the user has short hair.

[0139] The invented headset is configured to stimulate various areas of the head by electrodes in various shapes and sizes. The headset may include electrodes configured to stimulate the forehead region.

[0140] Figure 28 is a perspective anterior view of a donned headset 10, the headset configured, and the front electrodes 110a and 110b adapted and positioned, to stimulate specific nerve branches in the forehead region. These specific nerve branches include the supratrochlear 120a, 120b and supraorbital 122a, 122b nerves, both of which are superficial branches of the trigeminal nerve. Electrodes 122a and 122b may be configured to have a narrow elongated contour and to be at least partially aligned with the contour of the eyebrows 112a and 112b in order to achieve the desired nerve depolarization with minimal stimulation intensity and sufficient level of sensory comfort. Electrodes 110a and 110b may be configured to have a minimal size and a particular shape, in order to minimize unpleasant sensation that may be elicited when pain nerve fibers disposed on the periosteum of the skull bone are activated. Electrodes 110a and 110b may be also configured to ensure proper stimulation of the target nerves despite the wide range of morphological variables in the target population. An additional consideration that may influence the dimensions of the electrode and specifically its length, is an expected deviation that may occur in the rotational placement of headset 10, when donned by the user. Therefore, the electrodes may preferably be configured to have sufficient length to ensure placement of at least part of the electrode above the target nerves, even when such rotational deviation occurs.

[0141] Figure 29 is an illustration of an embodiment of electrode 110a which electrode may be configured for stimulation of the supraorbital region. Electrode 110a may include a biocompatible conducting material configured to face the skin surface, and may be configured to include an electrode backing attached to a conductive contact surface. The backing may contain at least one conductive material or element that may be electrically coupled with the conductive contact surface.

[0142] Electrode 110a may be configured to have a conductive contact surface with the following dimensions:

(i) a long dimension (D_L) having a length of 20mm to 55mm, 25 to 50mm, or 30 to 45mm.

(ii) a narrow dimension (D_N) having a length of 10mm to 30mm, 10 to 25, or 12 to 20mm.

Concave contour E has a concavity defined by boundary points G and F, which points are disposed at opposite ends of the concavity.

[0143] Typically, A/L is at least 0.5mm, A being an area bounded by dotted line K and the concavity;

L being a length of line K (between boundary points G and F), (L) being at least 10mm, wherein a line disposed between a first point on the concave contour and a second point on the perimeter of electrode 110a, on a side opposite to concave contour E, and aligned in perpendicular fashion with respect to contour E at the first point, has a length H, and wherein, over an entirety of the concave contour,

$$H_{\max}/H_{\min} \leq 2.5$$

H_{\max} being a maximum value of H over this entirety; and H_{\min} being a minimum value of H over this entirety.

[0144] The distance between two electrodes configured to stimulate the supraorbital region may be in a range of 5-45mm, 8-35mm, or 8-25mm. Additional electrodes may be located on the headset in order to stimulate other nerves, for example, the zygomaticotemporal nerve or the auriculotemporal nerve. The headset may also include electrodes that are configured to stimulate the occiput region.

[0145] Figure 30 provides an embodiment in which electrodes 146a and 146b are configured to be located at the rear aspect (facing the occiput) of headset 10 in order to stimulate nerves at the occiput region 140, such as the left side greater occipital nerve 142a and the right side greater occipital nerve 142b. Additional electrodes may be located in the headset and configured to stimulate other nerves in the head region, such as left and right lesser occipital nerves 143a and 143b.

[0146] In order to stimulate the branches 142a and 142b of the greater occipital nerve, the electrodes may

be configured to be positioned above the nerve branches at approximately the level of the occipital protuberance, where the branches of the greater occipital nerve become superficial after piercing the trapezius fascia. Stimulation below this anatomical area may cause disadvantageous contraction of the upper neck muscles while stimulation at a higher area may cause disadvantageous contraction of the scapularis muscle and may cause painful sensation due to proximity to the nociceptive nerve fibers of the skull periosteum. It is therefore important to ensure that stimulation performed with accurate placement of the electrodes and with electrodes that have appropriate dimensions that ensure effective stimulation with high level of sensory comfort and without overflow of the stimulation to nearby muscles. In some embodiments, the dimensions of electrodes **146a** and **146b** are preferably in the range of 20-50mm in length and 8-40mm in height; electrodes **146a** and **146b** may be disposed at a distance of 5-35mm from the occiput midline. More typically, electrodes **146a** and **146b** have a length within a range of 25-45mm and a height within a range of 10-25mm; electrodes **146a** and **146b** may be disposed at a distance of 8-25mm from the occiput midline.

[0147] Figure 31 illustrates a side perspective view of bilateral member **50a** which, according to one embodiment, is part of the inventive headset. According to certain features of the described preferred embodiments, member **50a** is configured to be rigid and preferably semi-rigid, having a curved portion **408** adapted to align behind and above the ear.

[0148] Figure 32 illustrates a perspective view of headset **10** on head **500**. Headset **10** may be configured to enable accurate placement on the head in a way that may be both repeatable and intuitive for a user without clinical expertise. Precise electrode placement over the target peripheral nerves and brain areas is essential in order to achieve the desired therapeutic benefits. When stimulating the head region, accurate electrode placement is especially important, since even slight deviation in the electrode position may elicit unpleasant sensation and even pain, due to stimulation over the periosteum of the skull bone, or may cause unwanted motor contraction of muscles such as the frontalis, temporalis, scapularis or the upper neck muscles.

[0149] Bilateral rigid and preferably semi-rigid member **50a** may be configured to enable the user to position headset **10** on his head **500** in a substantially accurate and repeatable manner. When curved bilateral member **50a** is positioned behind and above both ears, both the circumferential (rotational) and longitudinal placement of headset **10** are determined with respect to head **500**.

[0150] Headset **10** may be configured to include a recess **410** at its anterior portion, configured to be aligned with the glabella midline and above a nose bridge **506**. In order to ensure proper circumferential (rotational) and longitudinal placement of headset **10** with respect to head **500** without the need to use a mirror, the user may position his thumb on nose bridge **506** and one of his fingers

(of the same hand) on recess **410**, to ensure that headset **10** is accurately positioned.

[0151] The contour of frontal elastic member **40** of headset **10** may be configured to align with the anatomical lines of eyebrows **502** and an upper area of nose bridge **506**, such that when it is aligned by the user above the eyebrows, the headset rotational and longitudinal orientation is determined.

[0152] In order to suit each particular user, the rotational position of the bilateral semi-rigid members **50a**, relative to headset **10**, may be individually adjusted; semi-rigid members **50a** of different size and shape may be selected in order to optimally adjust the orientation of headset **10**; frontal elastic member **40** of various contours may be selected in order to adjust the anterior longitudinal orientation of the headset; and the position of recess **410** may be adjusted or headset **10** and its integrated electrodes may be configured for a non-symmetrical alignment, as necessary.

[0153] Posterior elastic member **30** of headset **10** may be configured to have a concave shape that may be aligned above the occipital protrusion and the nuchal line, thereby the longitudinal placement of headset **10**, and more specifically, the longitudinal placement of posterior elastic member, may be determined.

[0154] Figure 33 is a perspective anterior view of headset **10** with a "nose bridge" member **510**. "Nose bridge" member **510** may be configured to be located in the central area of elastic member **40**. "Nose bridge" member **510** may be rigid or semi-rigid, and may have two elongated portions adapted to be aligned at both sides of the upper part of the nose and the nose bridge. Positioning the "nose bridge" member over the nose may allow the user to determine headset **10** rotational and longitudinal placement.

[0155] The "nose bridge" member **510** may also be configured to further support member **40** against gravity. "Nose bridge" member **510** may be configured to be detachable from headset **10**. A "nose bridge" member **510** of various sizes and shapes may be selected for individual users. "Nose bridge" member **510** may be configured to be manually adjusted by the user for optimal adjustment to the nose of the user.

[0156] Figure 34 is a perspective view of headset **10** having eyeglasses **520**. Eyeglasses **520** may be adapted to be coupled to frontal elastic member **40**. In some embodiments, eyeglasses **520** may be configured to:

- be reversibly and repeatedly detachable from headset **10**;
- include various lenses such as optical lenses for improved eyesight, sunglasses, or non-optical transparent lenses;
- include highly dark lenses that may be used to block external light, for example, in order to assist during migraine attack or for relaxation.

[0157] Figure 35 is a perspective view illustration of

headset 10 having earphones such as bilateral earphones 522. In some embodiments, bilateral earphones 522 may be configured to be electrically connected to an at least semi-rigid bilateral member 50a.

[0158] In some embodiments, earphones 522 and bilateral member 50a may be configured such that earphones 522 are reversibly and repeatedly detachable from bilateral member 50a.

[0159] In some embodiments, bilateral member 50 may be adapted to include an internal space and an opening that may be served for storage of earphones 522 when earphones 522 are not in use. Bilateral member 50 may include a mechanism that pulls earphones 522 into a storage space within bilateral member 50a, when earphones 522 are not in use.

[0160] Figure 36 illustrates a perspective view of headset 10 along with a remote control or remote control handset 560, a mobile phone 570 and a laptop/PC 580.

[0161] In some embodiments, headset 10 may be configured to communicate wirelessly with remote control 560. Remote control 560 may be used by the user to send commands to headset 10, such as stimulation initiation or cessation commands, or commands to increase or decrease the stimulation intensity. Remote control 560 may also present various visual and audio indications for the user regarding the status of headset 10.

[0162] Headset 10 may be configured to wirelessly communicate with a mobile phone 570. The mobile phone interface may be used to present various data sent wirelessly by headset 10, for example, visual and audio indications regarding the status of headset 10 and usage logs.

[0163] Headset 10 may be configured to wirelessly communicate with laptop/PC 580. The mobile phone interface may be used to present various data sent wirelessly by headset 10, such as visual and audio indications regarding the status of headset 10 and usage logs.

[0164] Communication between headset 10 and remote control 560, mobile phone 570 and laptop 580 may be performed in various ways, known to those of ordinary skill in the art, for example by Bluetooth communication.

[0165] As used herein in the specification and in the claims section that follows, the term "monolithic" means structurally behaving as a single, at least semi-rigid whole.

[0166] As used herein in the specification and in the claims section that follows, the term "monolithically donnable", with respect to a headset, headset frame, or the like, refers to a structure enabling the donning of the headset, headset frame, or the like as a single, at least semi-rigid whole.

[0167] As used herein in the specification and in the claims section that follows, the term "operational mode", or the like, with respect to a headset or headset component, refers to a headset or headset component that is fitted onto the head of the user, in a suitable rotational and longitudinal disposition, with electrical stimulation being applied.

[0168] As used herein in the specification and in the claims section that follows, the term "donned mode", "donned", or the like, with respect to a headset or headset component, refers to a headset or headset component that is fitted onto the head of the user, in a suitable rotational and longitudinal disposition, with electrical stimulation being applied.

[0169] As used herein in the specification and in the claims section that follows, the term "integral" refers to a structure behaving as a single, whole structure. The term may be applied in particular to flexible structures such as an electrode pad.

[0170] It will be appreciated that certain features of the invention, which are, for clarity, described in the context of separate embodiments, may also be provided in combination in a single embodiment. Conversely, various features of the invention, which are, for brevity, described in the context of a single embodiment, may also be provided separately or in any suitable sub-combination. Similarly, the content of a claim depending from one or more particular claims may generally depend from the other, unspecified claims, or be combined with the content thereof, absent any specific, manifest incompatibility therebetween.

[0171] Although the invention has been described in conjunction with specific embodiments thereof, it is evident that many alternatives, modifications and variations will be apparent to those skilled in the art. The invention is defined in the appended claims.

Claims

1. A headset for use in delivering electrical stimulation to a skin surface of a head of a user, the headset comprising:

(a) a circumferential headset body, said body having a monolithic frame adapted to circumferentially fit around the head of the user, said body housing an electric circuit adapted to be connected to a power source; said headset body including an elastic arrangement, disposed on at least a portion of a circumference of said headset body; said elastic arrangement adapted to be tensioned along said circumference;

(b) at least one electrode base, mechanically and at least semi-rigidly connected to said headset body, and electrically associated with said electric circuit, said electrode base adapted to receive at least one electrode pad;

said headset body and said base adapted to orient a electrical stimulation surface of said pad towards the skin surface, during donning by the user; said elastic arrangement adapted such that, during said donning, said elastic arrangement radially urges said electrode base towards the skin surface such

that said electrode pad makes physical and electrical contact with the skin surface;
 said elastic arrangement and said electrode base adapted such that for various degrees of tensioning of said elastic arrangement, a circumferential position of said electrode base, with respect to said frame, is fixed in a unique position.

- 2. The headset of claim 1, said circumferential headset body having a front section adapted to fit around a front portion of the head, said at least one of said at least one electrode base being a front electrode base disposed on said front portion.
- 3. The headset of claim 2, said front section being a front mechanical element that is physically distinct from said circumferential headset body; said front mechanical element optionally spanning at most 40%, at most 35%, at most 30%, or at most 20%, of a circumference of said circumferential headset body; said front mechanical element optionally spanning within a range of 10% to 40%, 15% to 40%, 20% to 40%, 25% to 40%, or 25% to 35%, of a circumference of said circumferential headset body.
- 4. The headset of any one of claims 1 to 3, said circumferential headset body having a rear section adapted to fit around a rear portion of the head, at least one of said at least one electrode base being a rear electrode base disposed on said rear portion; said rear section optionally being a rear mechanical element that is physically distinct from said circumferential headset body; said rear mechanical element optionally spanning at most 40%, at most 35%, at most 30%, or at most 20%, of a circumference of said circumferential headset body; said rear mechanical element optionally spanning within a range of 10% to 40%, 15% to 40%, 20% to 40%, 25% to 40%, or 25% to 35%, of a circumference of said circumferential headset body. said front and rear mechanical elements optionally spanning, in total, 45% to 75%, 50% to 75%, 55% to 75%, or 55% to 70%, of said circumference.
- 5. The headset of any one of claims 1 to 4, said frame including at least semi-rigid side components, bi-laterally disposed on said frame, and forming side portions of said circumference of said headset body; said side components optionally spanning, in total, 15% to 50%, 20% to 50%, 25% to 50%, 30% to 50%, 35% to 50%, or 30% to 45%, of said circumference; each of said side components optionally having an element disposed generally perpendicular to said circumference, and adapted, in a donned mode, to fit behind an ear of the user; a circumferential rigidity of said side components op-

5
10
15
20
25
30
35
40
45
50
55

tionally exceeding a circumferential rigidity of said front section and said rear section;
 a circumferential elasticity of said front section and said rear section optionally exceeding a circumferential elasticity of said side components.

- 6. The headset of any one of claims 1 to 5, said frame including a positioning system for angular and longitudinal positioning of said headset body, said positioning system including at least one at least semi-rigid side component, said side component having:
 - (i) a first, elongated element, forming a portion of said circumference, and adapted to fit above an ear of the user, to determine said longitudinal positioning, and
 - (ii) a second element disposed generally perpendicular to said elongated element, and adapted to fit behind said ear, to determine said angular positioning of said headset body.
- 7. The headset of any one of claims 1 to 6, said frame including at least a first bi-lateral size adjustment mechanism adapted to fixedly adjust said circumference of said headset body; said adjustment mechanism optionally being rigid or at least semi-rigid; said frame including said first bi-lateral size adjustment mechanism, and optionally, a second bi-lateral size adjustment mechanism, said adjustment mechanisms optionally adapted to adjust said circumference of said headset body, said first adjustment mechanism connecting said side components to said front section, and said second adjustment mechanism connecting said side components to said rear section; said first and second adjustment mechanisms optionally adapted to enable adjustment of said circumference of said headset body while a circumferential position of said side components remains fixed.
- 8. The headset of any one of claims 1 to 7, said frame adapted such that along at least 30%, at least 40%, at least 50%, or at least 60% of a length of said circumference, said frame is substantially non-elastic.
- 9. The headset of any one of claims 1 to 8, said headset body adapted to juxtapose a contact surface of an electrical device opposite or against the skin surface, said elastic arrangement adapted to radially urge said electrical device towards said skin surface such that a contact surface of said electrical device makes physical contact with said skin surface; said elastic arrangement adapted such that for various degrees of tensioning of said elastic arrangement, a circumferential position of said electrical device is fixed in a unique position; said electrical device optionally including a sensor adapted to sense a body parameter associated with

the head of the user.

10. The headset of any one of claims 1 to 9, further comprising said at least one electrode pad, said pad including:

(a) a water-absorbent layer having a biocompatible contact surface, said contact surface adapted to be juxtaposed against the skin surface;
 (b) an electrode backing, attached to said water-absorbent layer, said backing containing at least one electrically conductive material or element, said conductive material or element being electrically connected with said water-absorbent layer, when said water-absorbent layer is filled with water;

said biocompatible contact surface having:

- (i) a long dimension (D_L) having a maximum length of 20mm to 55mm;
 (ii) a narrow dimension (D_N) having a maximum length of 10mm to 25mm;

wherein a first side of a perimeter of said biocompatible contact surface has a generally concave contour having a concavity defined by first and second boundary points disposed at opposite ends of said concavity,

wherein:

$$A/L \geq 0.5\text{mm}$$

A being an area bounded by said line and said concavity;

L being a length of a line between said boundary points;

said length (**L**) being at least 10mm;

wherein a line disposed between a first point on said concave contour and a second point on said perimeter, on a side opposite said concave contour, and aligned in perpendicular fashion with respect to said contour at said first point, has a length **H**, and wherein, over an entirety of said concave contour,

$$H_{\max}/H_{\min} \leq 2.5,$$

H_{\max} being a maximum value of **H** over said entirety; and

H_{\min} being a minimum value of **H** over said entirety.

11. The headset of any one of claims 1 to 10, said at least one electrode pad including:

(a) a water-absorbent layer having a biocompatible, conductive contact surface, said contact surface adapted to be juxtaposed against the skin surface;

(b) an electrically conductive layer having a broad first face juxtaposed against, or attached to, said water-absorbent layer, said conductive layer containing at least one electrically conductive material or element, said conductive layer adapted to transfer an electrical current from a broad second face, distal to said first face, to said water-absorbent layer, via said first face;

said water-absorbent layer optionally including at least one material selected from the group consisting of a non-woven fabric, felt or sponge.

12. The headset of claim 11, said electrically conductive layer having, on said second face, a layer of electrically conductive paint, preferably disposed in a mesh pattern;

13. The headset of claim 11 or claim 12, said electrically conductive layer containing a carbon foil; said carbon foil optionally having a resistivity within a range of 1-180 ohm/square or 30-100 ohm/square; said carbon foil optionally having a thickness within a range of 30-1500 microns or 50-200 microns.

14. The headset of claim 12, said water-absorbent layer and said electrically conductive layer having said layer of electrically conductive paint forming an integral structure.

15. The headset of any one of claims 1 to 14, said electrode base having:

(a) a housing including a floor, and a flexible circumferential member surrounding said floor, and having a flexible circumferential wall extending generally above a perimeter of said floor, said wall ending in a circumferential rim; said floor and said flexible circumferential member forming a cavity adapted to receive an electrically conductive electrode pad; and

(b) an electrically conductive material, disposed at least partially above, or within, said floor; said conductive layer adapted to be electrically associated to an electrical circuit, by means of an electrical conductor, and, when said pad is inserted, to electrically communicate with said electrode pad;

said rim and said flexible circumferential wall adapted such that a pressure exerted against said electrode base, generally perpendicular to said rim, and towards a skin surface of a user, urges said rim against said skin surface, to substantially fluidly seal

between said cavity and an ambient or external environment;

and optionally, wherein, within said rim are circumferentially disposed a plurality of sealing fingers containing a volume, said sealing fingers adapted such that, when said rim is urged against the skin surface, said plurality of sealing fingers substantially seal between said volume and a volume external to said sealing fingers;

or optionally, said rim including, or consisting essentially of, a circumferentially disposed plurality of sealing fingers, said sealing fingers adapted such that, when said pressure is exerted, said plurality of sealing fingers substantially seal between said cavity and a volume external to said rim.

Patentansprüche

1. Headset zur Verwendung beim Liefern von elektrischer Stimulation an eine Hautoberfläche eines Kopfes eines Benutzers, wobei das Headset Folgendes umfasst:

(a) einen umfänglichen Headset-Körper, wobei der Körper einen monolithischen Rahmen aufweist, der dazu eingerichtet ist, umfänglich um den Kopf des Benutzers herum zu passen, wobei der Körper einen elektrischen Schaltkreis aufnimmt, der dazu eingerichtet ist, an eine Energiequelle angeschlossen zu werden; wobei der Headset-Körper eine elastische Anordnung umfasst, die an zumindest einem Teil eines Umfangs des Headset-Körpers angeordnet ist; wobei die elastische Anordnung dazu eingerichtet ist, entlang des Umfangs gespannt zu werden;

(b) zumindest eine Elektrodenbasis, die mechanisch und zumindest halbstar mit dem Headset-Körper verbunden ist und elektrisch dem elektrischen Schaltkreis zugeordnet ist, wobei die Elektrodenbasis dazu eingerichtet ist, zumindest ein Elektrodenkissen aufzunehmen;

wobei der Headset-Körper und die Basis dazu eingerichtet sind, eine elektrische Stimulationsoberfläche des Kissens in Richtung der Hautoberfläche während des Anlegens durch den Benutzer zu orientieren;

wobei die elastische Anordnung so eingerichtet ist, dass, während des Anlegens, die elastische Anordnung die Elektrodenbasis radial in Richtung der Hautoberfläche so treibt, dass das Elektrodenkissen in physischen und elektrischen Kontakt mit der Hautoberfläche kommt;

wobei die elastische Anordnung und die Elektrodenbasis so eingerichtet sind, dass für verschiedene Spannungsgrade der elastischen Anordnung eine Umfangsposition der Elektrodenbasis, in Bezug auf

den Rahmen, in einer einzigen Position fest ist.

2. Headset nach Anspruch 1, wobei der umfängliche Headset-Körper einen vorderen Abschnitt aufweist, der dazu eingerichtet ist, um einen vorderen Teil des Kopfes herum zu passen, wobei die zumindest eine der zumindest einen Elektrodenbasis eine vordere Elektrodenbasis ist, die an dem vorderen Teil angeordnet ist.
3. Headset nach Anspruch 2, wobei der vordere Abschnitt ein vorderes mechanisches Element ist, das physikalisch unterschiedlich vom umfänglichen Headset-Körper ist;
- wobei das vordere mechanische Element optional höchstens 40%, höchstens 35%, höchstens 30%, oder höchstens 20%, eines Umfangs des umfänglichen Headset-Körpers umspannt; wobei das vordere mechanische Element optional innerhalb eines Bereiches von 10% bis 40%, 15% bis 40%, 20% bis 40%, 25% bis 40%, oder 25% bis 35%, eines Umfangs des umfänglichen Headset-Körpers umspannt.
4. Headset nach einem der Ansprüche 1 bis 3, wobei der umfängliche Headset-Körper einen hinteren Abschnitt aufweist, der dazu eingerichtet ist, um einen hinteren Teil des Kopfes herum zu passen, wobei die zumindest eine der zumindest einen Elektrodenbasis eine hintere Elektrodenbasis ist, die an dem hinteren Teil angeordnet ist.
- wobei der hintere Abschnitt optional ein hinteres mechanisches Element ist, das physikalisch unterschiedlich vom umfänglichen Headset-Körper ist;
- wobei das hintere mechanische Element optional höchstens 40%, höchstens 35%, höchstens 30%, oder höchstens 20%, eines Umfangs des umfänglichen Headset-Körpers umspannt;
- wobei das hintere mechanische Element optional innerhalb eines Bereiches von 10% bis 40%, 15% bis 40%, 20% bis 40%, 25% bis 40%, oder 25% bis 35%, eines Umfangs des umfänglichen Headset-Körpers umspannt;
- wobei das vordere und hintere mechanische Element optional insgesamt 45% bis 75%, 50% bis 75%, 55% bis 75%, oder 55% bis 70%, des Umfangs umspannen.
5. Headset nach einem der Ansprüche 1 bis 4, wobei der Rahmen zumindest halbstarre Seitenbauteile umfasst, die bilateral an dem Rahmen angeordnet sind und Seitenteile des Umfangs des Headset-Körpers bilden;
- wobei die Seitenbauteile optional insgesamt 15% bis 50%, 20% bis 50%, 25% bis 50%, 30% bis 50%, 35% bis 50%, oder 30% bis 45%, des Umfangs umspannen;
- wobei jedes der Seitenbauteile optional ein Element

- aufweist, das im Allgemeinen senkrecht zum Umfang angeordnet ist und, in einem angelegten Modus, dazu eingerichtet ist, hinter einem Ohr des Benutzers zu passen;
 wobei eine umfängliche Starrheit der Seitenbauteile optional eine umfängliche Starrheit des vorderen Abschnittes und des hinteren Abschnittes überschreitet;
 wobei eine umfängliche Elastizität des vorderen Abschnittes und des hinteren Abschnittes optional eine umfängliche Elastizität der Seitenkomponenten überschreitet.
6. Headset nach einem der Ansprüche 1 bis 5, wobei der Rahmen ein Positionierungssystem zur Winkel- und Längspositionierung des Headset-Körpers umfasst, wobei das Positionierungssystem zumindest ein zumindest halbstarres Seitenbauteil umfasst, wobei das Seitenbauteil Folgendes aufweist:
- (i) ein erstes langgestrecktes Element, das einen Teil des Umfangs bildet und dazu eingerichtet ist, oberhalb eines Ohrs des Benutzers zu passen, um die Längspositionierung zu bestimmen, und
- (ii) ein zweites Element, das im Allgemeinen senkrecht zum langgestreckten Element angeordnet ist und dazu eingerichtet ist, hinter dem Ohr zu passen, um die Winkelpositionierung des Headset-Körpers zu bestimmen.
7. Headset nach einem der Ansprüche 1 bis 6, wobei der Rahmen einen ersten bilateralen Größen-Justiermechanismus umfasst, der dazu eingerichtet ist, den Umfang des Headset-Körpers fest zu justieren, wobei der Justiermechanismus optional starr oder zumindest halbstarr ist;
 wobei der Rahmen den ersten bilateralen Größen-Justiermechanismus und optional einen zweiten bilateralen Justiermechanismus umfasst, wobei die Justiermechanismen optional dazu eingerichtet sind, den Umfang des Headset-Körpers zu justieren, wobei der erste Justiermechanismus die Seitenbauteile mit dem vorderen Abschnitt verbindet, und wobei der zweite Justiermechanismus die Seitenbauteile mit dem hinteren Abschnitt verbindet;
 wobei der erste und zweite Justiermechanismus optional dazu eingerichtet sind, die Justierung des Umfangs des Headset-Körpers zu ermöglichen, während eine Umfangsposition der Seitenbauteile fest bleibt.
8. Headset nach einem der Ansprüche 1 bis 7, wobei der Rahmen so eingerichtet ist, dass entlang zumindest 30%, zumindest 40%, zumindest 50%, oder zumindest 60%, einer Länge des Umfangs der Rahmen im Wesentlichen nicht-elastisch ist.
9. Headset nach einem der Ansprüche 1 bis 8, wobei der Headset-Körper dazu eingerichtet ist, eine Kontaktfläche einer elektrischen Vorrichtung gegenüberliegend oder an der Hautoberfläche anzulegen, wobei die elastische Anordnung dazu eingerichtet ist, die elektrische Vorrichtung radial in Richtung der Hautoberfläche so zu treiben, dass eine Kontaktfläche der elektrischen Vorrichtung in physischen Kontakt mit der Hautoberfläche kommt; wobei die elastische Anordnung so eingerichtet ist, dass für verschiedene Spannungsgrade der elastischen Anordnung eine Umfangsposition der elektrischen Vorrichtung in einer einzigen Position fest ist;
 wobei die elektrische Vorrichtung optional einen Sensor umfasst, der dazu eingerichtet ist, einen Körperparameter in Verbindung mit dem Kopf des Benutzers abzutasten.
10. Headset nach einem der Ansprüche 1 bis 9, ferner umfassend zumindest einen Elektrodenkissen, wobei das Elektrodenkissen Folgendes aufweist:
- (a) eine wasserabsorbierende Schicht, die eine biokompatible Berührungsfläche aufweist, wobei die Berührungsfläche dazu eingerichtet ist, an der Hautoberfläche angelegt zu werden;
- (b) einen Elektrodenträger, der an der wasserabsorbierenden Schicht angebracht ist, wobei der Träger zumindest ein elektrisch leitendes Material oder Element enthält, wobei das leitende Material oder Element elektrisch mit der wasserabsorbierenden Schicht verbunden ist, wenn die wasserabsorbierende Schicht mit Wasser gefüllt ist;
- wobei die biokompatible Berührungsfläche Folgendes aufweist:
- (i) eine lange Abmessung (D_L), die eine maximale Länge von 20mm bis 55mm aufweist;
- (ii) eine schmale Abmessung (D_N), die eine maximale Länge von 10mm bis 25mm aufweist;
- wobei eine erste Seite eines Perimeters der biokompatiblen Berührungsfläche eine im Allgemeinen konkave Kontur aufweist, die eine Konkavität aufweist, die durch erste und zweite an entgegengesetzten Enden der Konkavität angeordnete Begrenzungspunkte definiert ist,
 wobei:
- $$A/L \geq 0,5\text{mm}$$
- A eine Fläche ist, die durch die Linie und die Konkavität begrenzt ist;
 L eine Länge einer Linie zwischen den Begrenzungspunkten ist;

wobei die Länge (L) zumindest 10mm ist;
wobei eine Linie, die zwischen einem ersten Punkt an der konkaven Kontur und einem zweiten Punkt am Perimeter, an einer der konkaven Kontur gegenüberliegenden Seite, angeordnet ist und die in senkrechter Art in Bezug auf die Kontur am ersten Punkt ausgerichtet ist, eine Länge H aufweist, und wobei über eine Gesamtheit der konkaven Kontur,

$$H_{\max}/H_{\min} \leq 2,5,$$

wobei H_{\max} ein Maximalwert von H über die Gesamtheit ist; und
wobei H_{\min} ein Minimalwert von H über die Gesamtheit ist.

11. Headset nach einem der Ansprüche 1 bis 10, wobei zumindest eine Elektrodenkissen Folgendes aufweist:

(a) eine wasserabsorbierende Schicht, die eine biokompatible, leitende Berührungsfläche aufweist, wobei die Berührungsfläche dazu eingerichtet ist, an der Hautoberfläche angelegt zu werden;

(b) eine elektrisch leitende Schicht, die eine breite erste Seite aufweist, die an der wasserabsorbierenden Schicht angelegt oder befestigt ist, wobei die leitende Schicht zumindest ein elektrisch leitendes Material oder Element enthält, wobei die leitende Schicht dazu eingerichtet ist, einen elektrischen Strom von einer zur ersten Seite distalen, breiten zweiten Seite zur wasserabsorbierenden Schicht über die erste Seite zu übertragen;

wobei die wasserabsorbierende Schicht optional zumindest ein Material umfasst, das aus der Gruppe bestehend aus Vliesstoff, Filz oder Schaumstoff ausgewählt ist.

12. Headset nach Anspruch 11, wobei die elektrisch leitende Schicht an der zweiten Seite eine Schicht aus elektrisch leitendem Anstrich, vorzugsweise in einem Maschenmuster angeordnet, aufweist.
13. Headset nach Anspruch 11 oder Anspruch 12, wobei die elektrisch leitende Schicht eine Kohlenstoffolie enthält;
wobei die Kohlenstoffolie optional eine Widerstandsfähigkeit in einem Bereich von 1-180 Ohm/Quadrat oder 30-100 Ohm/Quadrat aufweist; wobei die Kohlenstoffolie optional eine Dicke in einem Bereich von 30-1500 Mikron oder 50-200 Mikron aufweist.

14. Headset nach Anspruch 12, wobei die wasserabsorbierende Schicht und die elektrisch leitende Schicht die Schicht aus elektrisch leitendem Anstrich, die eine einstückige Struktur bildet, aufweisen.

15. Headset nach einem der Ansprüche 1 bis 14, wobei die Elektrodenbasis Folgendes aufweist:

(a) ein Gehäuse umfassend einen Boden, und wobei ein flexibles umfängliches Element den Boden umgibt, und aufweisend eine flexible umfängliche Wand, die sich im Allgemeinen über einem Perimeter des Bodens erstreckt, wobei die Wand in einem umfänglichen Rand endet; wobei der Boden und das flexible umfängliche Element einen Hohlraum bilden, der dazu geeignet ist, ein elektrisch leitendes Elektrodenkissen aufzunehmen; und

(b) ein elektrisch leitendes Material, das zumindest teilweise oberhalb, oder innerhalb, des Bodens angeordnet ist; wobei die leitende Schicht dazu eingerichtet ist, elektrisch einem elektrischen Schaltkreis mittels eines elektrischen Leiters zugeordnet zu werden und, wenn das Kissen eingesetzt ist, elektrisch mit dem Elektrodenkissen zu kommunizieren;

wobei der Rand und die flexible umfängliche Wand so eingerichtet sind, dass ein gegen die Elektrodenbasis ausgeübter Druck, im Allgemeinen senkrecht zum Rand, und in Richtung einer Hautoberfläche eines Benutzers, den Rand gegen die Hautoberfläche treibt, um im Wesentlichen zwischen dem Hohlraum und einer umgebenden oder äußeren Umgebung fluidmäßig abzudichten;

und optional, wobei, innerhalb des Randes eine Vielzahl von ein Volumen enthaltenden Abdichtungsfingern umfangsmäßig angeordnet sind, wobei die Abdichtungsfinger so eingerichtet sind, dass, wenn der Rand gegen die Hautoberfläche getrieben wird, die Vielzahl von Abdichtungsfingern im Wesentlichen zwischen dem Volumen und einem Volumen außerhalb der Abdichtungsfinger abdichten;

oder optional, wobei der Rand eine umfangsmäßig angeordnete Vielzahl von Abdichtungsfingern umfasst, oder im Wesentlichen aus diesen besteht, wobei die Abdichtungsfinger so eingerichtet sind, dass, wenn Druck ausgeübt wird, die Vielzahl von Abdichtungsfingern im Wesentlichen zwischen dem Hohlraum und einem Volumen außerhalb des Randes abdichten.

Revendications

1. Casque destiné à être utilisé pour délivrer une stimulation électrique à la surface de la peau de la tête d'un utilisateur, le casque comprenant :

(a) un corps de casque circonférentiel, ledit corps possédant un cadre monolithique conçu pour s'adapter circonférentiellement autour de la tête de l'utilisateur, ledit corps abritant un circuit électrique conçu pour se brancher à une source d'alimentation ; ledit corps de casque comportant un agencement élastique disposé sur au moins une partie de la circonférence dudit corps de casque ; ledit agencement élastique étant conçu pour être mis en tension le long de ladite circonférence ;

(b) au moins une base d'électrode reliée mécaniquement et au moins de manière semi-rigide audit corps de casque, et associée électriquement audit circuit électrique, ladite base d'électrode étant conçue pour recevoir au moins une pastille d'électrode ;

ledit corps de casque et ladite base étant conçus pour orienter une surface de stimulation électrique de ladite pastille en direction de la surface de la peau, pendant la mise en place par l'utilisateur ; ledit agencement élastique étant conçu de sorte que, pendant ladite mise en place, ledit agencement élastique pousse radialement ladite base d'électrode en direction de la surface de la peau de sorte que ladite pastille d'électrode entre en contact physique et électrique avec la surface de la peau ;

ledit agencement élastique et ladite base d'électrode étant conçus de sorte que pour divers degrés de mise en tension dudit agencement élastique, la position circonférentielle de ladite base d'électrode, par rapport audit cadre, soit fixée dans une position unique.

2. Casque selon la revendication 1, ledit corps de casque circonférentiel possédant une section avant conçue pour s'adapter autour d'une portion avant de la tête, ladite au moins une de ladite au moins une base d'électrode étant une base d'électrode avant disposée sur ladite portion avant.
3. Casque selon la revendication 2, ladite section avant étant un élément mécanique avant qui est physiquement différent dudit corps de casque circonférentiel ; ledit élément mécanique avant recouvrant éventuellement au plus 40 %, au plus 35 %, au plus 30 % ou au plus 20 %, de la circonférence dudit corps de casque circonférentiel ; ledit élément mécanique avant recouvrant éventuellement une plage de 10 % à 40 %, 15 % à 40 %, 20 % à 40 %, 25 % à 40 %, ou 25 % à 35 %, de la circonférence dudit corps de casque circonférentiel.
4. Casque selon l'une quelconque des revendications 1 à 3, ledit corps de casque circonférentiel possédant une section arrière conçue pour s'adapter autour d'une portion arrière de la tête, au moins l'une de

ladite au moins une base d'électrode étant une base d'électrode arrière disposée sur ladite portion arrière ;

ladite section arrière étant éventuellement un élément mécanique arrière qui est physiquement différent dudit corps de casque circonférentiel ;

ledit élément mécanique arrière recouvrant éventuellement au plus 40 %, au plus 35 %, au plus 30 % ou au plus 20 %, de la circonférence dudit corps de casque circonférentiel ;

ledit élément mécanique arrière recouvrant éventuellement une plage de 10 % à 40 %, 15 % à 40 %, 20 % à 40 %, 25 % à 40 %, ou 25 % à 35 %, de la circonférence dudit corps de casque circonférentiel ;

lesdits éléments mécaniques avant et arrière recouvrant éventuellement, au total, 45 % à 75 %, 50 % à 75 %, 55 % à 75 % ou 55 % à 70 % de ladite circonférence.

5. Casque selon l'une quelconque des revendications 1 à 4, ledit cadre comportant des composants latéraux au moins semi-rigides disposés de part et d'autre dudit cadre, et formant des portions latérales de ladite circonférence dudit corps de casque ; lesdits composants latéraux recouvrant éventuellement, au total, 15 % à 50 %, 20 % à 50 %, 25 % à 50 %, 30 % à 50 %, 35 % à 50 %, ou 30 % à 45 %, de ladite circonférence ; chacun desdits composants latéraux possédant éventuellement un élément placé généralement perpendiculairement à ladite circonférence, et conçu, en mode mis en place, pour s'adapter derrière une oreille de l'utilisateur ; la rigidité circonférentielle desdits composants latéraux dépassant éventuellement la rigidité circonférentielle de ladite section avant et ladite section arrière ; l'élasticité circonférentielle de ladite section avant et ladite section arrière dépassant éventuellement l'élasticité circonférentielle desdits composants latéraux.

6. Casque selon l'une quelconque des revendications 1 à 5, ledit cadre comportant un système de positionnement pour le positionnement angulaire et longitudinal dudit corps de casque, ledit système de positionnement comportant au moins l'un dudit composant latéral au moins semi-rigide, ledit composant latéral possédant :
 - (i) un premier élément allongé formant une portion de ladite circonférence et conçu pour s'adapter au-dessus d'une oreille de l'utilisateur, pour déterminer ledit positionnement longitudinal, et
 - (ii) un second élément disposé généralement perpendiculairement audit élément allongé et conçu pour s'adapter en-dessous de ladite

- oreille, pour déterminer ledit positionnement angulaire dudit corps de casque.
7. Casque selon l'une quelconque des revendications 1 à 6, ledit cadre comportant au moins un premier mécanisme d'ajustement de taille bilatéral conçu pour ajuster de manière fixe ladite circonférence dudit corps de casque ; ledit mécanisme d'ajustement étant éventuellement rigide ou au moins semi-rigide ; ledit cadre comportant ledit premier mécanisme d'ajustement de taille bilatéral, et, éventuellement, un second mécanisme d'ajustement de taille bilatéral, lesdits mécanismes d'ajustement étant éventuellement conçus pour ajuster ladite circonférence dudit corps de casque, ledit premier mécanisme d'ajustement reliant lesdits composants latéraux à ladite section avant, et ledit second mécanisme d'ajustement reliant lesdits composants latéraux à ladite section arrière ; lesdits premier et second mécanismes d'ajustement étant éventuellement conçus pour permettre l'ajustement de ladite circonférence dudit corps de casque alors que la position circonferentielle desdits composants latéraux reste fixe.
8. Casque selon l'une quelconque des revendications 1 à 7, ledit cadre étant conçu de sorte que le long d'au moins 30 %, au moins 40 %, au moins 50 %, au moins 60 % de la longueur de ladite circonférence, ledit cadre est pratiquement non élastique.
9. Casque selon l'une quelconque des revendications 1 à 8, ledit corps de casque étant conçu pour juxtaposer une surface de contact d'un dispositif électrique à l'opposé de ou contre la surface de la peau, ledit agencement élastique étant conçu pour pousser radialement ledit dispositif électrique en direction de ladite surface de la peau de sorte qu'une surface de contact dudit dispositif électrique entre en contact physique avec ladite surface de la peau ; ledit agencement élastique étant conçu de sorte que pour divers degrés de mise en tension dudit agencement élastique, la position circonferentielle dudit dispositif électrique soit fixée dans une position unique ; ledit dispositif électrique comportant éventuellement un capteur conçu pour détecter un paramètre corporel associé à la tête de l'utilisateur.
10. Casque selon l'une quelconque des revendications 1 à 9, comprenant en outre ladite au moins une pastille d'électrode, ladite pastille comportant :
- (a) une couche hydroabsorbante possédant une surface de contact biocompatible, ladite surface de contact étant conçue pour être juxtaposée contre la surface de la peau ;
- (b) un support d'électrode fixé sur ladite couche hydroabsorbante, ledit support contenant au moins un matériau ou élément électroconducteur, ledit matériau ou élément conducteur étant connecté électriquement à ladite couche hydroabsorbante lorsque ladite couche hydroabsorbante est remplie d'eau ;
- ladite surface de contact biocompatible possédant :
- (i) une grande dimension (D_L) présentant une longueur maximale de 20 mm à 55 mm ;
- (ii) une dimension étroite (D_N) présentant une longueur maximale de 10 mm à 25 mm ;
- un premier côté du périmètre de ladite surface de contact biocompatible présentant un contour généralement concave possédant une concavité définie par des premier et second points limites placés à des extrémités opposées de ladite concavité, dans lequel :
- $$A/L \geq 0,5 \text{ mm}$$
- A** représentant la surface limitée par ladite ligne et ladite concavité ;
- L** représentant la longueur de la ligne entre lesdits points limites ;
- ladite longueur (**L**) étant supérieure ou égale à 10 mm ;
- dans lequel la ligne située entre un premier point dudit contour concave et un second point dudit périmètre, sur un côté opposé audit contour concave, et alignée de façon perpendiculaire par rapport audit contour au niveau dudit premier point, possède une longueur **H**, et, dans lequel, sur la totalité dudit contour concave,
- $$H_{\max}/H_{\min} \leq 2,5,$$
- H_{max}** représentant une valeur maximale de **H** sur ladite totalité ; et
- H_{min}** représentant une valeur minimale de **H** sur ladite totalité.
11. Casque selon l'une quelconque des revendications 1 à 10, ladite au moins une pastille d'électrode comportant :
- (a) une couche hydroabsorbante possédant une surface de contact conductrice biocompatible, ladite surface de contact étant conçue pour être juxtaposée contre la surface de la peau ;
- (b) une couche électroconductrice possédant une première face large juxtaposée contre, ou fixée à, ladite couche hydroabsorbante, ladite couche conductrice contenant au moins un ma-

- tériau ou élément électroconducteur, ladite couche conductrice étant conçue pour transférer un courant électrique d'une seconde face large, distale par rapport à la première face, à ladite couche hydroabsorbante, via ladite première face ; 5
- ladite couche hydroabsorbante comportant éventuellement au moins un matériau choisi dans le groupe constitué par un tissu non tissé, un feutre ou une éponge. 10
- 12.** Casque selon la revendication 11, ladite couche électroconductrice possédant, sur ladite seconde face, une couche de peinture électroconductrice, de préférence disposée en motif maillé. 15
- 13.** Casque selon la revendication 11 ou 12, ladite couche électroconductrice contenant une feuille de carbone ; 20
 ladite feuille de carbone présentant éventuellement une résistivité se trouvant dans la plage de 1 à 180 ohm/carré ou 30 à 100 ohm/carré ;
 ladite feuille de carbone présentant éventuellement une épaisseur se trouvant dans la plage de 30 à 1500 microns ou de 50 à 200 microns. 25
- 14.** Casque selon la revendication 12, ladite couche hydroabsorbante et ladite couche électroconductrice comportant ladite couche de peinture électroconductrice formant une structure d'un seul tenant. 30
- 15.** Casque selon l'une quelconque des revendications 1 à 14, ladite base d'électrode possédant : 35
- (a) un boîtier comportant un sol, et un élément circunférentiel flexible entourant ledit sol, et possédant une paroi circunférentielle flexible s'étendant généralement au-dessus du périmètre dudit sol, ladite paroi se terminant en rebord circunférentiel ; ledit sol et ledit élément circunférentiel flexible formant une cavité conçue pour recevoir une pastille d'électrode électroconductrice ; et 40
- (b) un matériau électroconducteur, disposé au moins en partie au-dessus, ou au sein, dudit sol ; ladite couche conductrice étant conçue pour être électriquement associée à un circuit électrique, au moyen d'un conducteur électrique, et, lorsque ladite pastille est insérée, pour communiquer électriquement avec ladite pastille d'électrode ; 50
- ledit rebord et ladite paroi circunférentielle flexible étant conçus de sorte qu'une pression exercée contre ladite base d'électrode, généralement perpendiculairement audit rebord, et en direction de la surface de la peau d'un utilisateur, pousse ledit rebord contre 55

ladite surface de la peau, pour former un joint pratiquement étanche entre ladite cavité et un environnement ambiant ou externe ; et, éventuellement, au sein dudit rebord, étant disposés une pluralité de doigts d'étanchéité contenant un volume, lesdits doigts d'étanchéité étant conçus de sorte que, lorsque le rebord est poussé contre la surface de la peau, ladite pluralité de doigts d'étanchéité forment pratiquement un joint entre ledit volume et un volume externe auxdits doigts d'étanchéité ; ou, éventuellement, ledit rebord comportant, ou se composant essentiellement de, une pluralité de doigts d'étanchéité disposée de manière circunférentielle, lesdits doigts d'étanchéité étant conçus de sorte que, lorsque ladite pression est exercée, ladite pluralité de doigts d'étanchéité forme pratiquement un joint entre ladite cavité et un volume externe audit rebord.

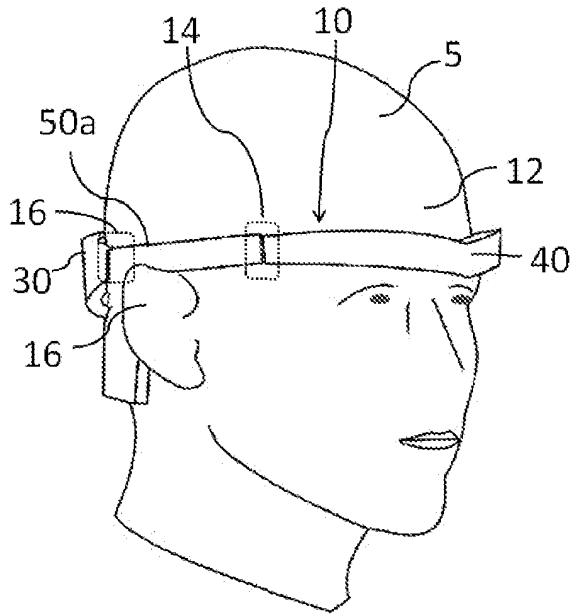

Fig. 1

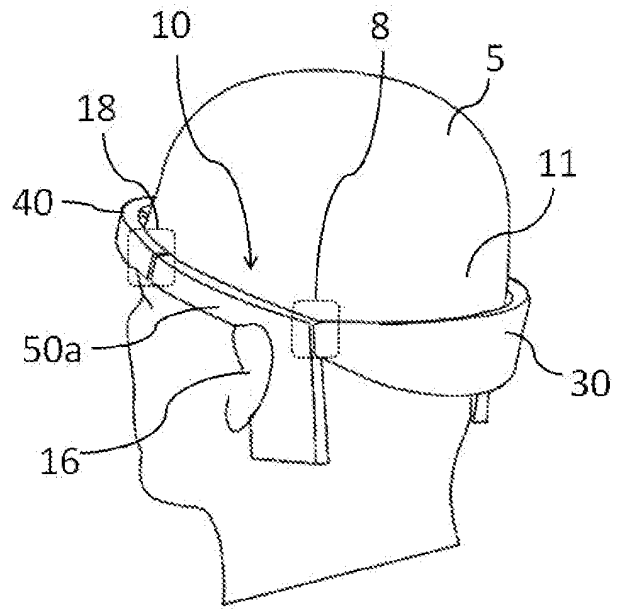

Fig. 1A

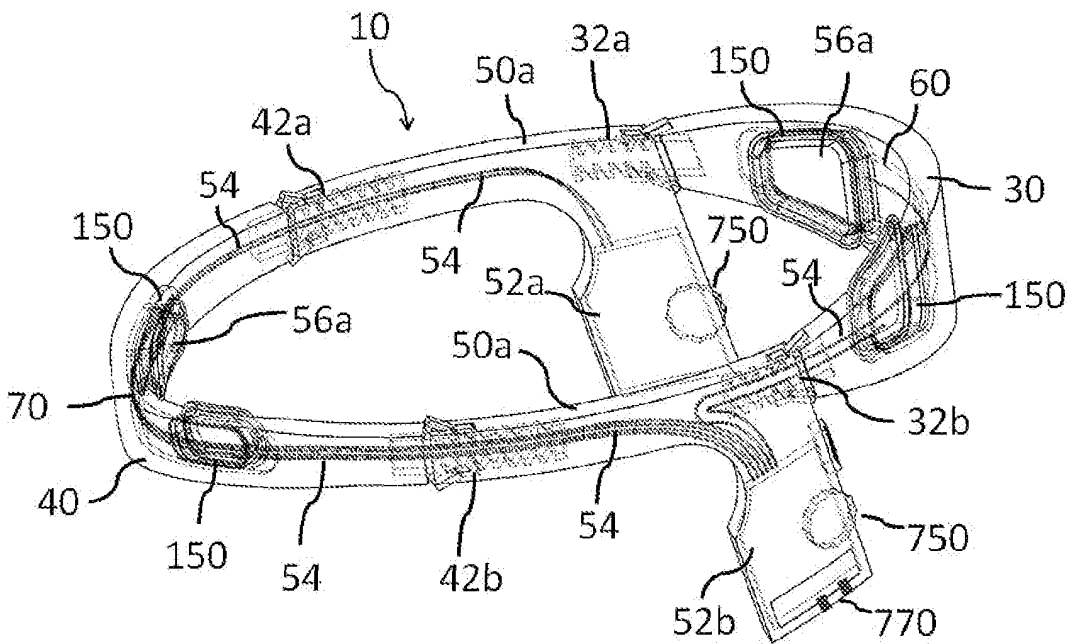

Fig. 2

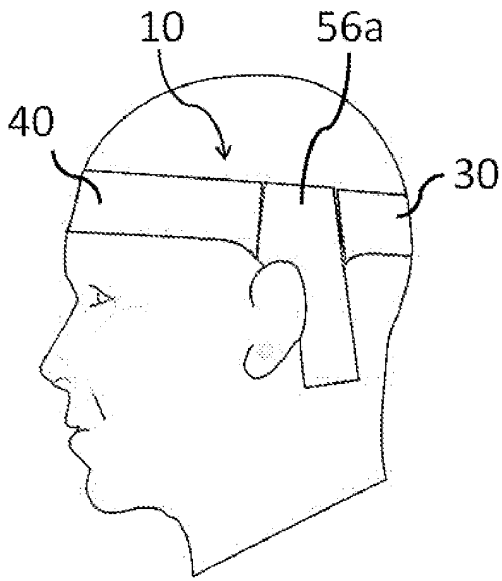

Fig. 3

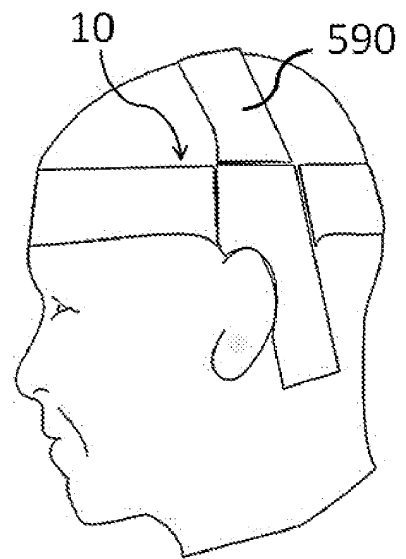

Fig. 4

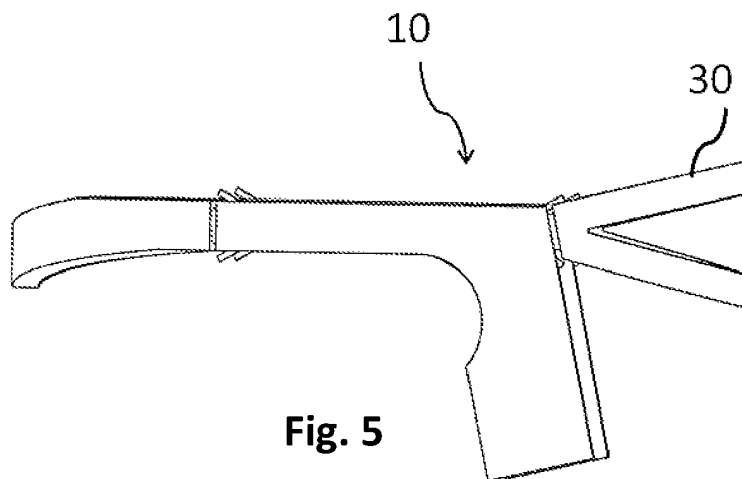

Fig. 5

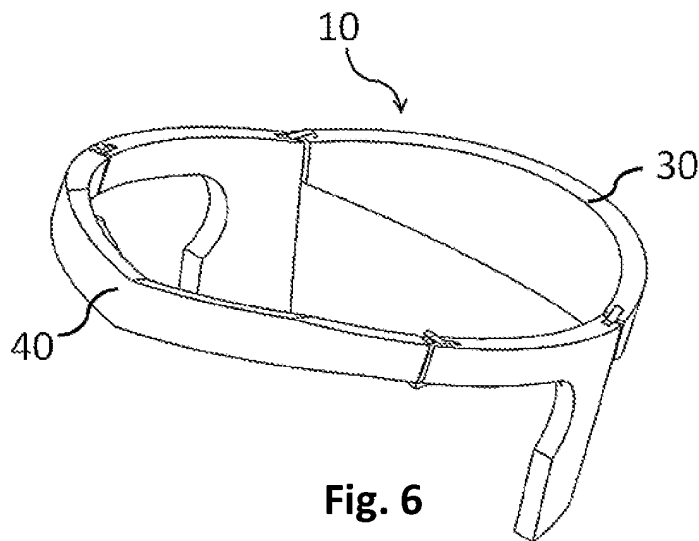

Fig. 6

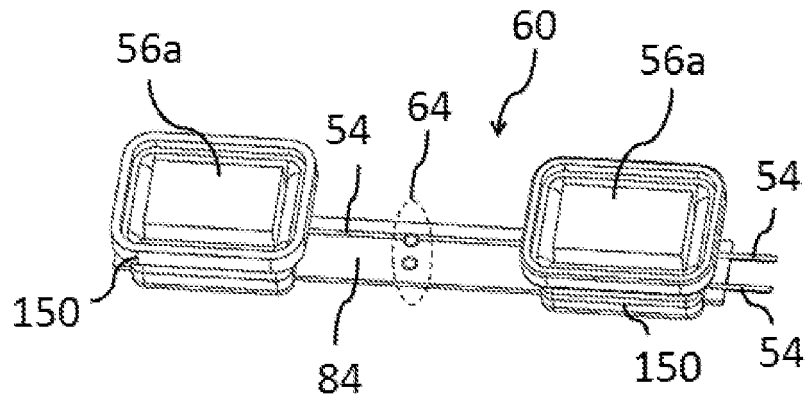

Fig. 7

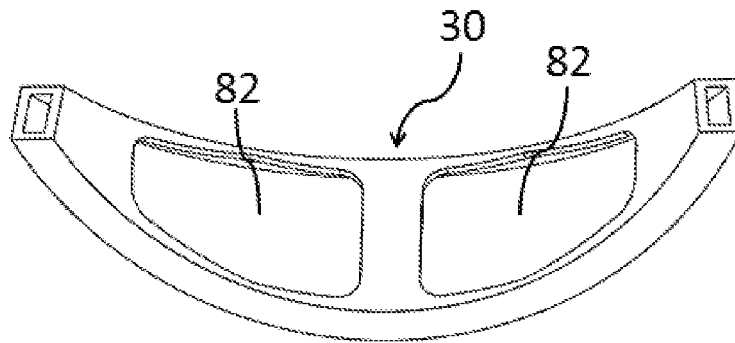

Fig. 7A

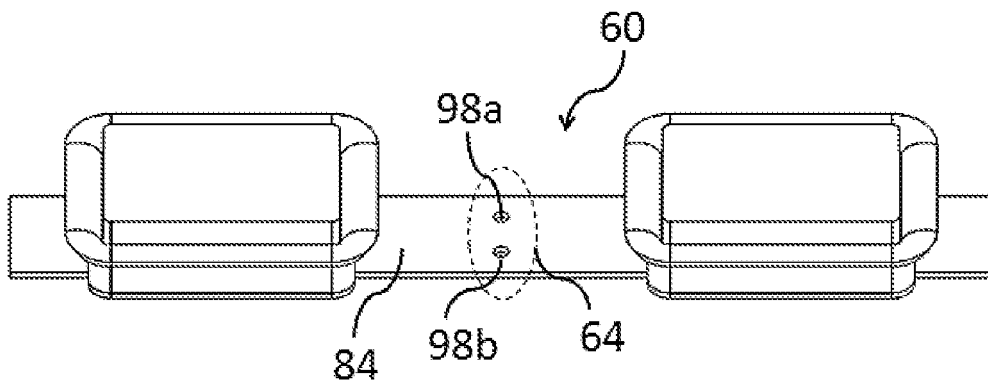

Fig. 8

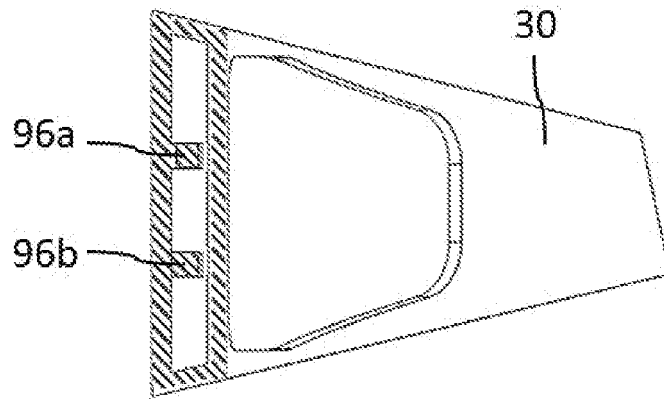

Fig. 8A

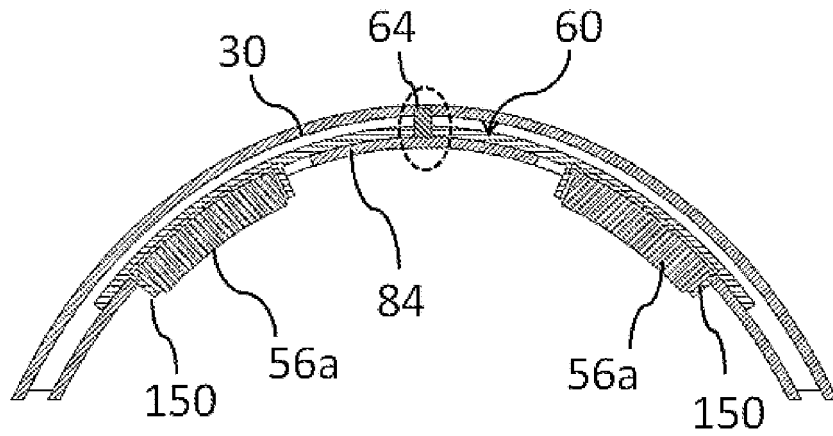

Fig. 9

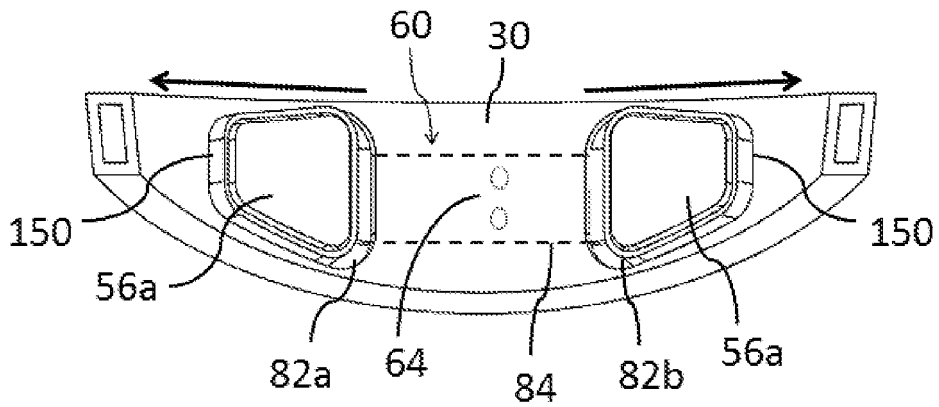

Fig. 10

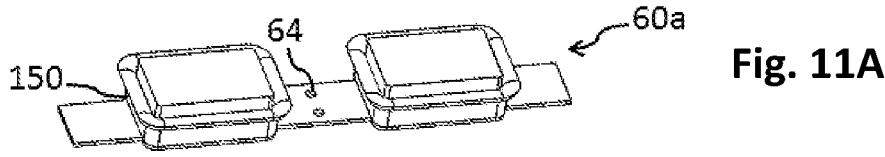

Fig. 11A

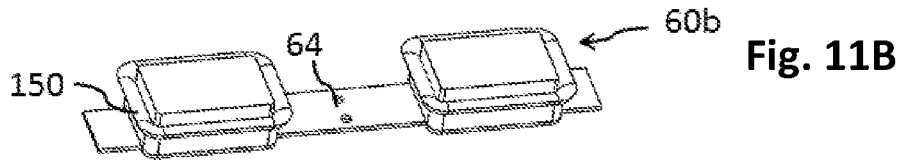

Fig. 11B

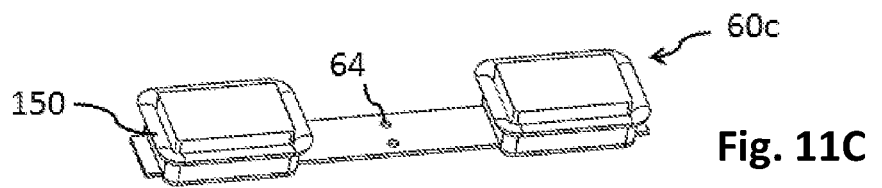

Fig. 11C

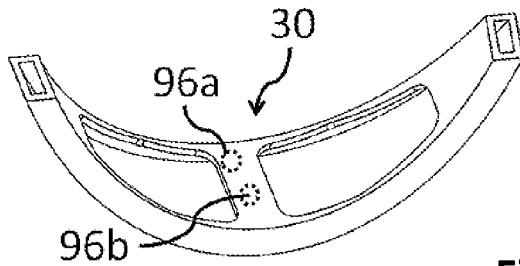

Fig. 11D

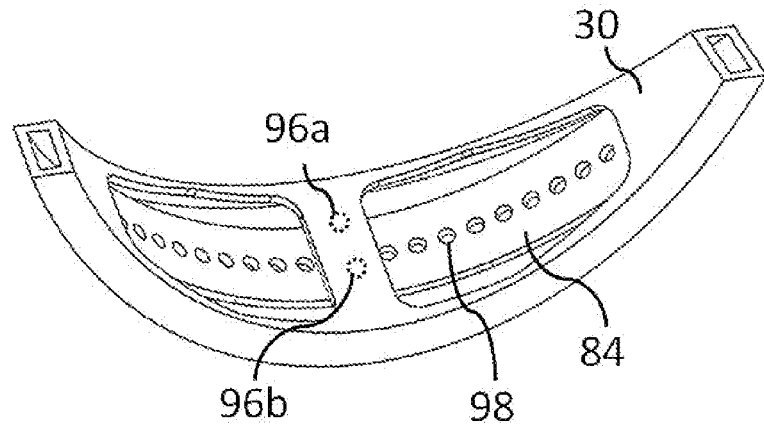

Fig. 12

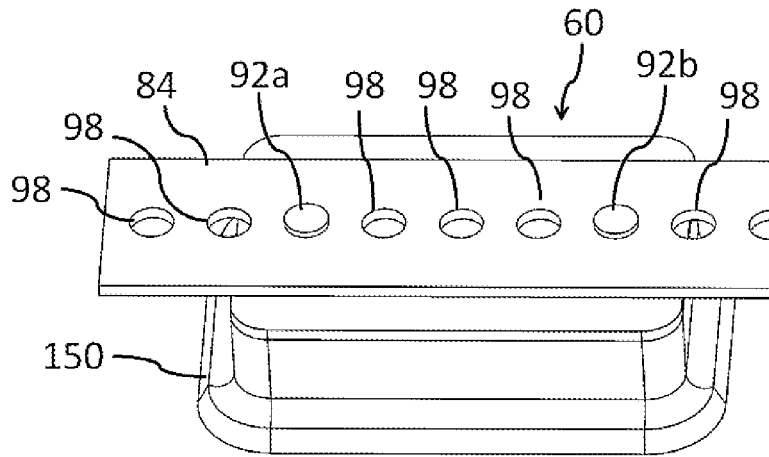

Fig. 13

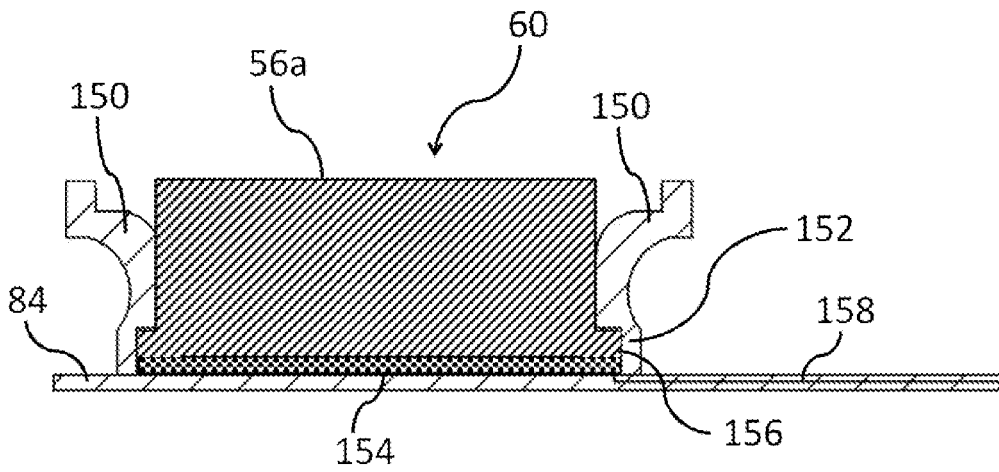

Fig. 14

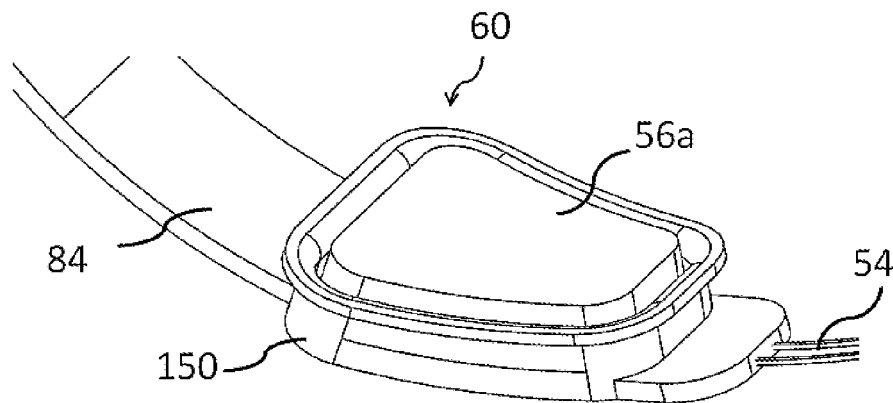

Fig. 15A

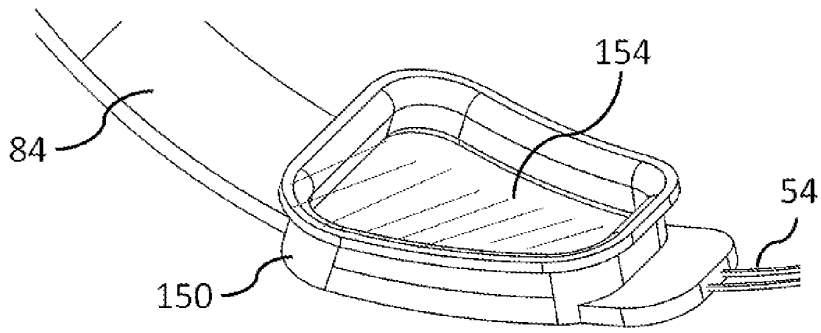

Fig. 15B

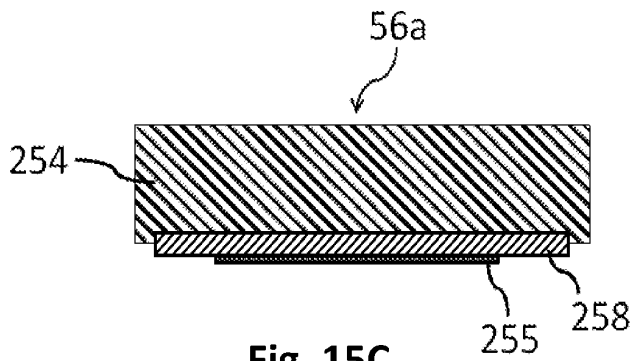

Fig. 15C

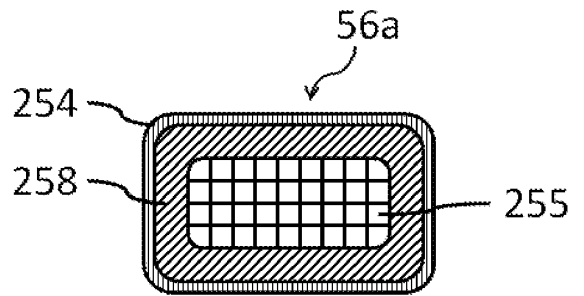

Fig. 15D

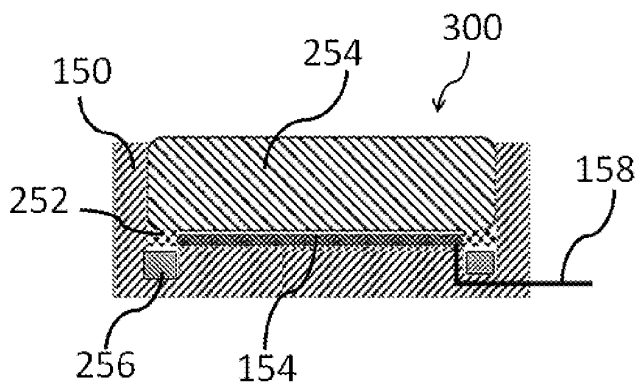

Fig. 16A

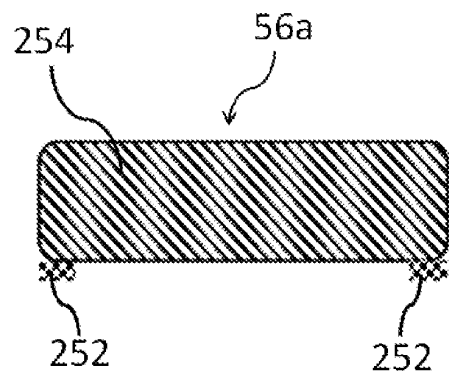

Fig. 16B

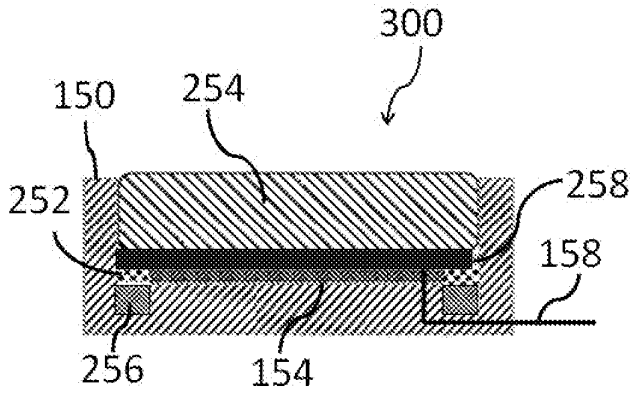

Fig. 17A

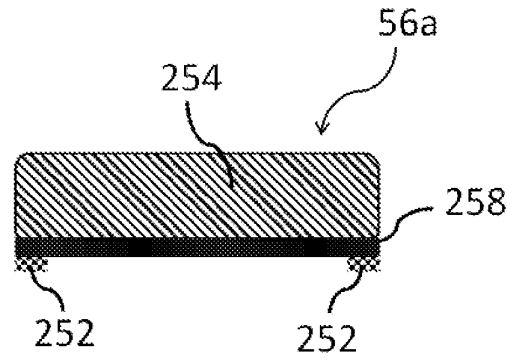

Fig. 17B

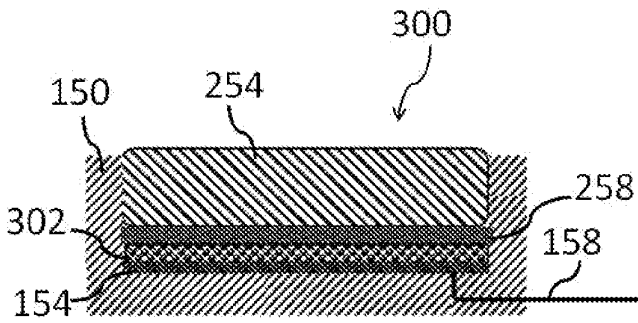

Fig. 18A

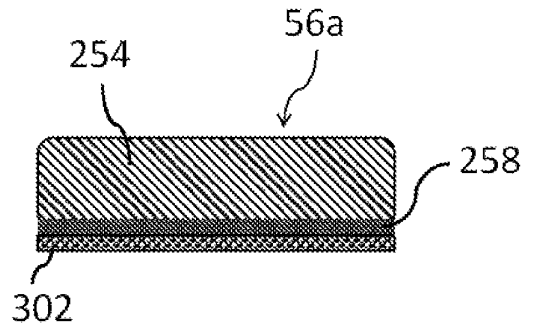

Fig. 18B

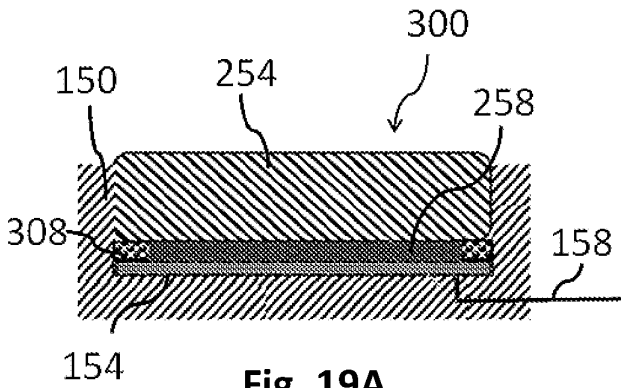

Fig. 19A

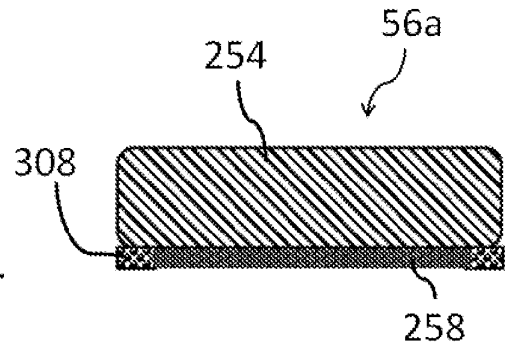

Fig. 19B

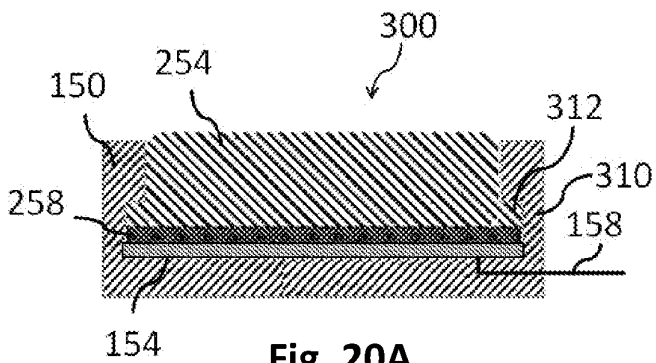

Fig. 20A

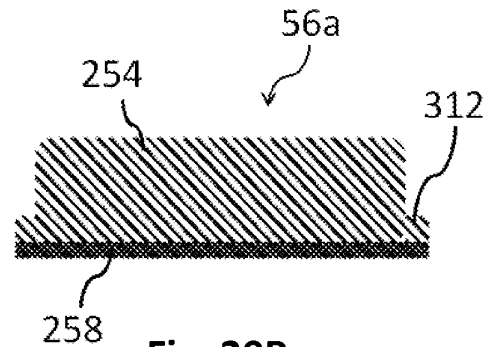

Fig. 20B

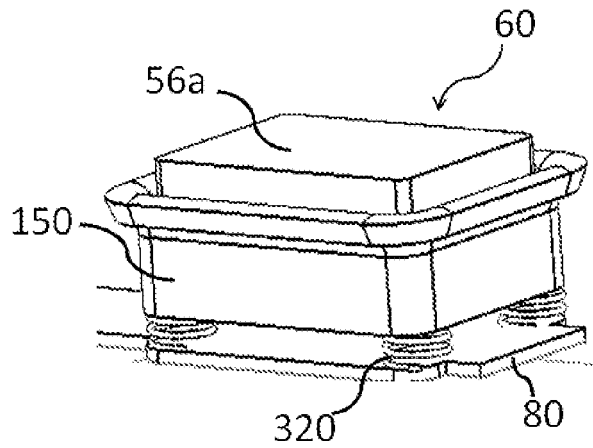

Fig. 21

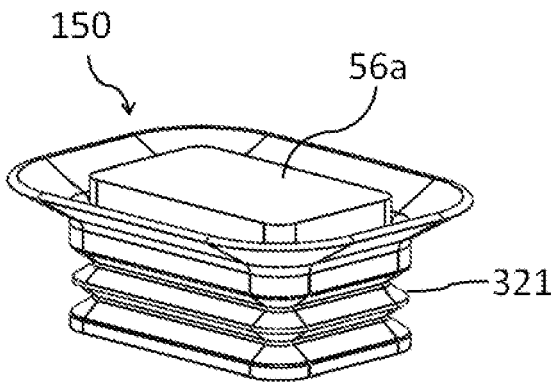

Fig. 21A

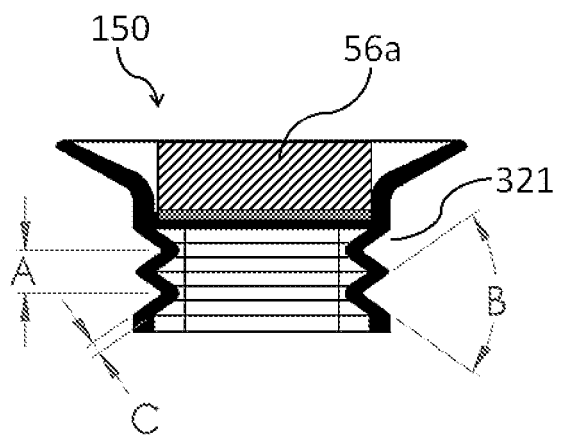

Fig. 21B

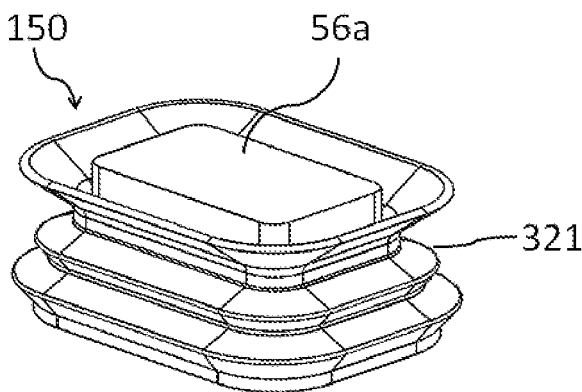

Fig. 21C

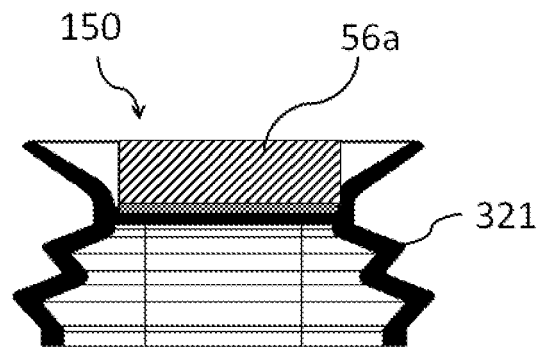

Fig. 21D

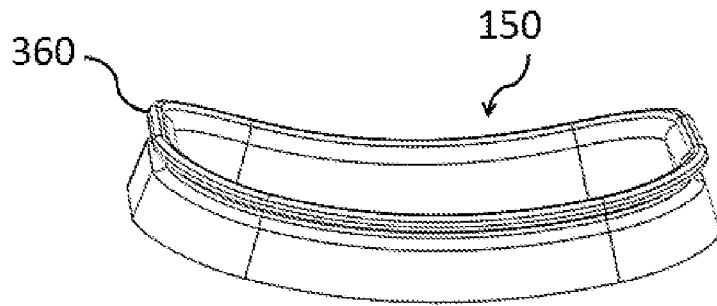

Fig. 22

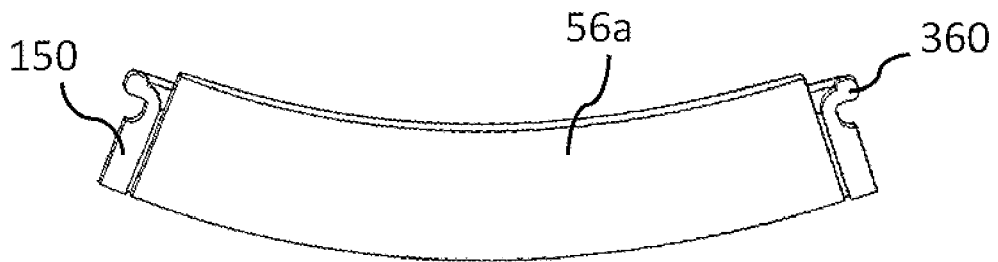

Fig. 23



Fig. 24

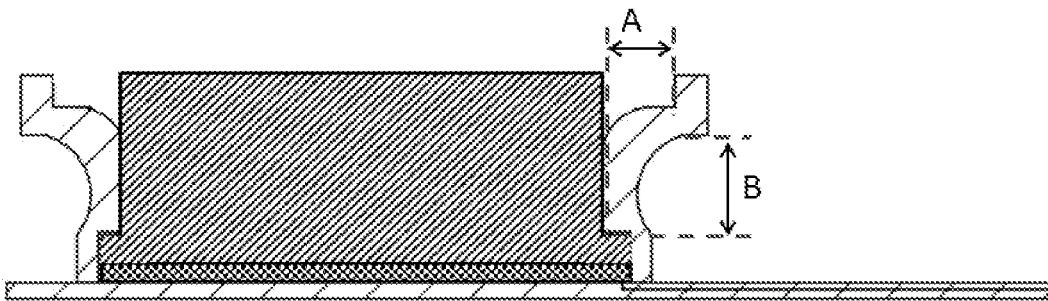

Fig. 25

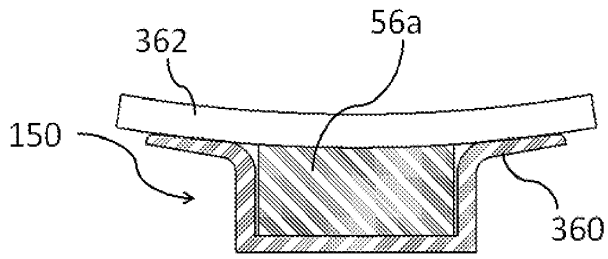

Fig. 25A

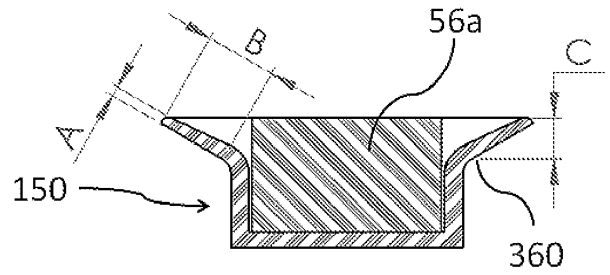

Fig. 25B

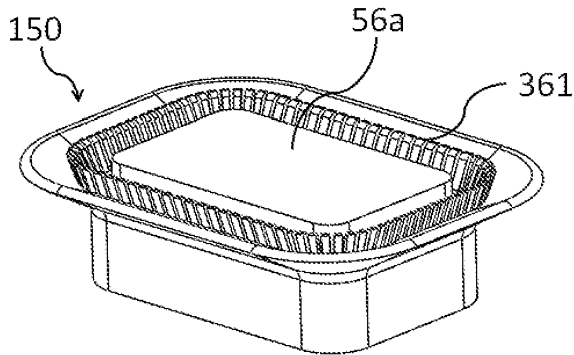

Fig. 25C

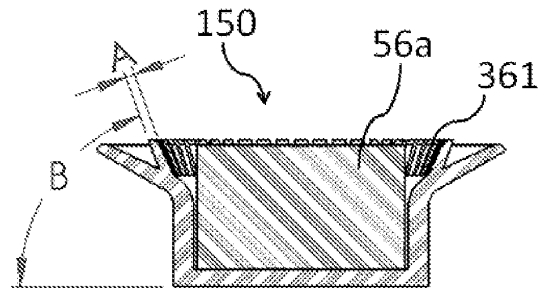

Fig. 25D

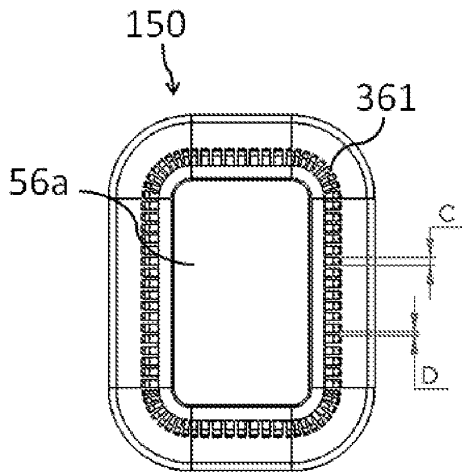

Fig. 25E

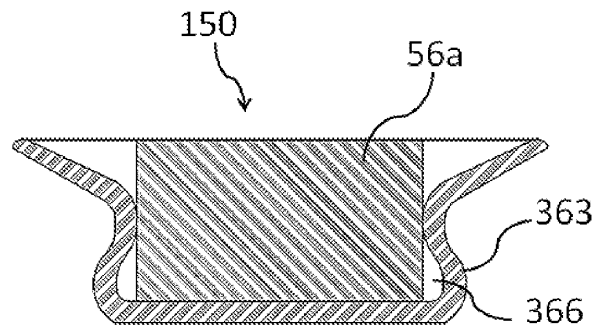

Fig. 25F

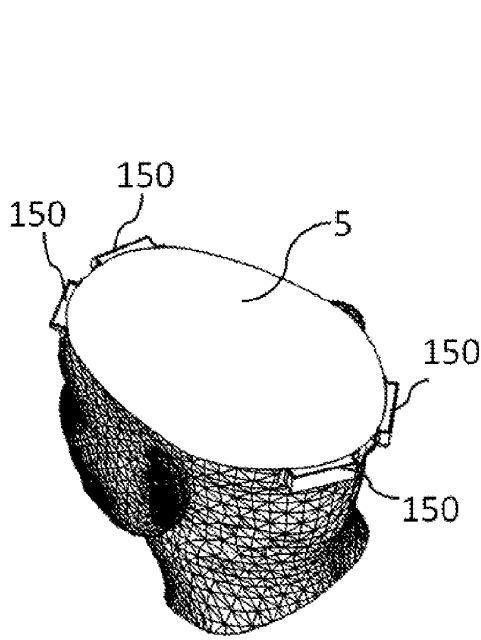

Fig. 25H

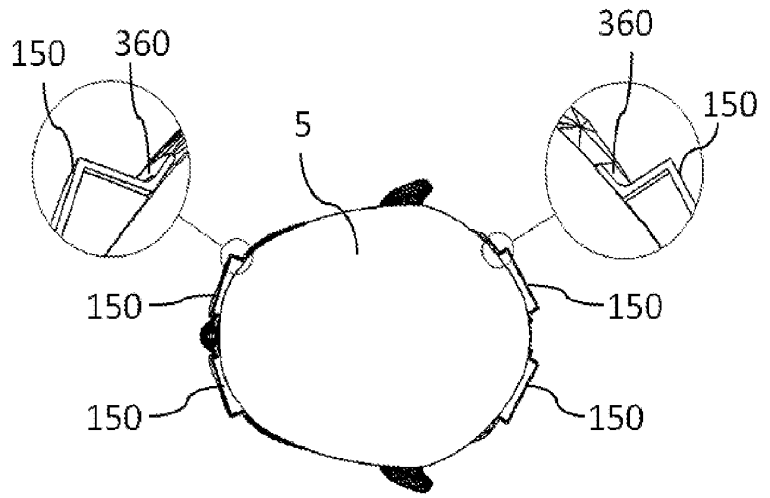

Fig. 25G

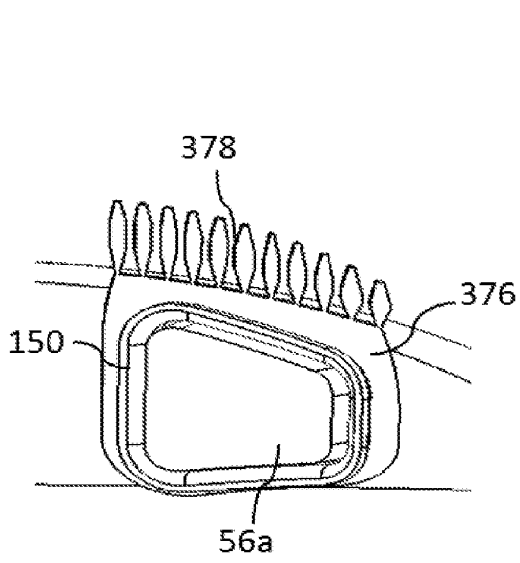

Fig. 26

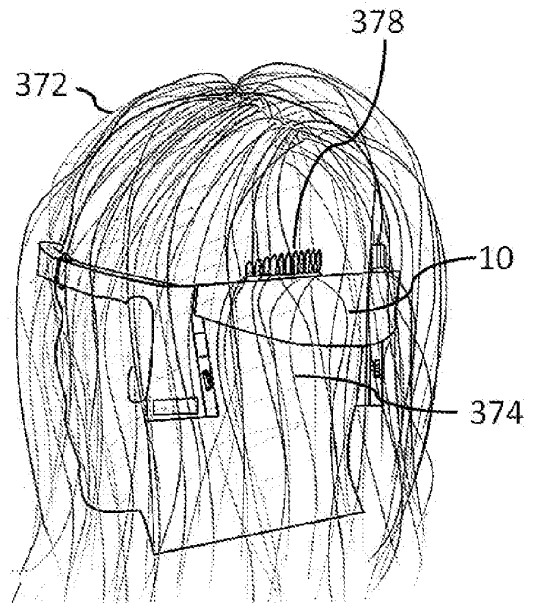

Fig. 27

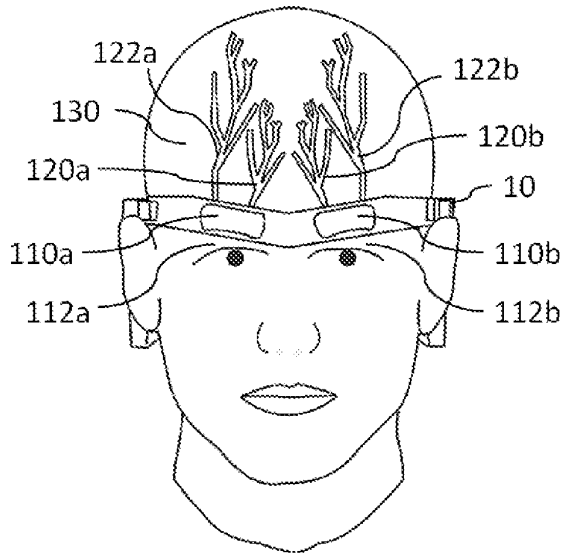

Fig. 28

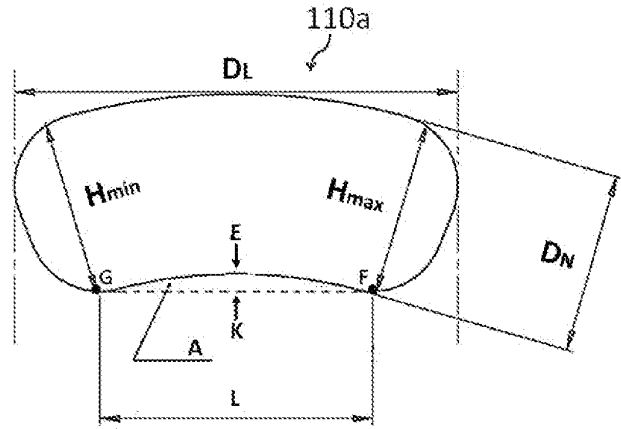

Fig. 29

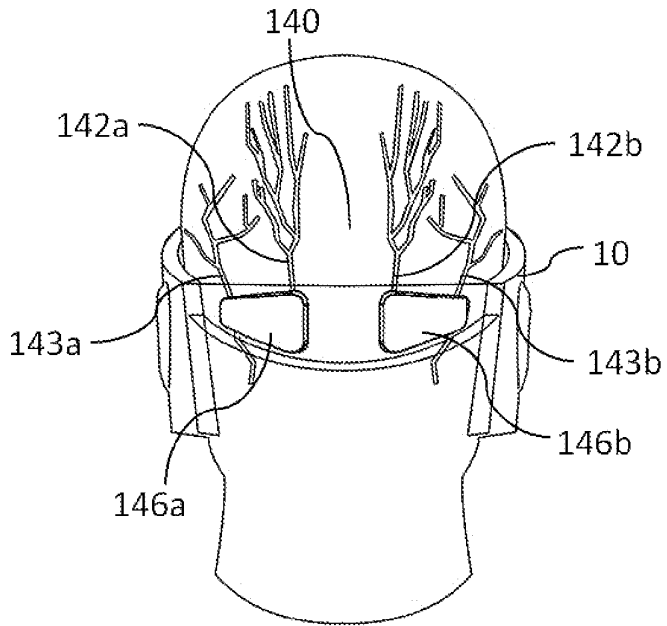

Fig. 30

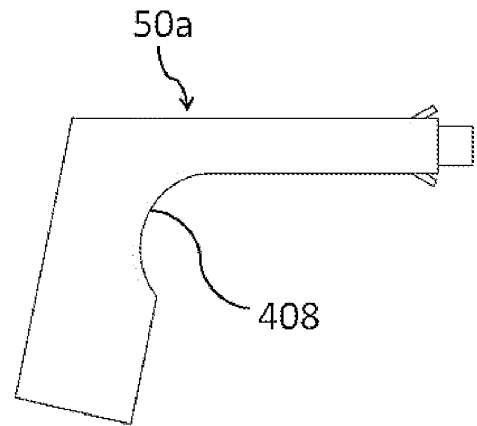

Fig. 31

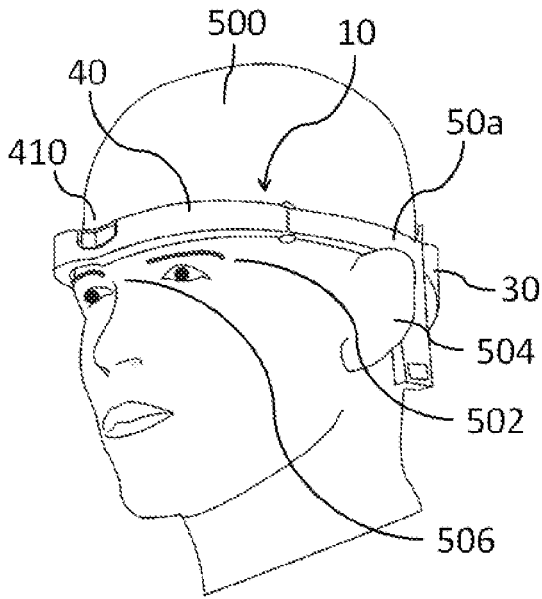

Fig. 32

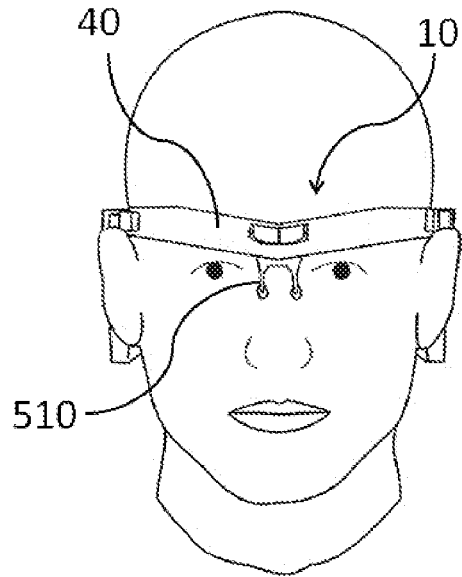

Fig. 33

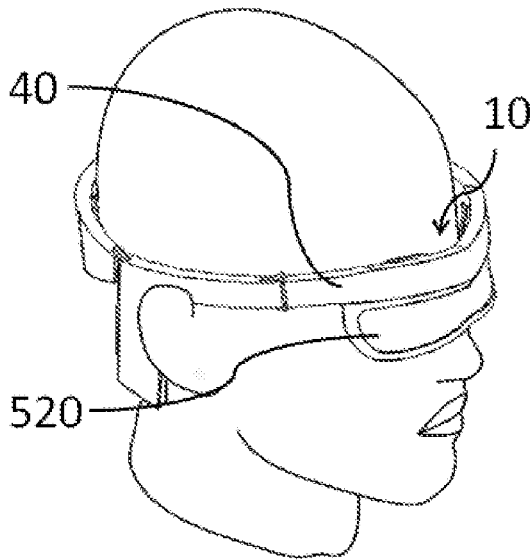

Fig. 34

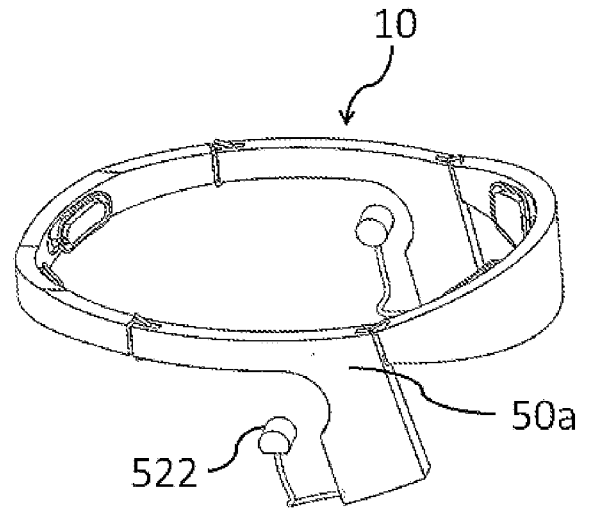

Fig. 35

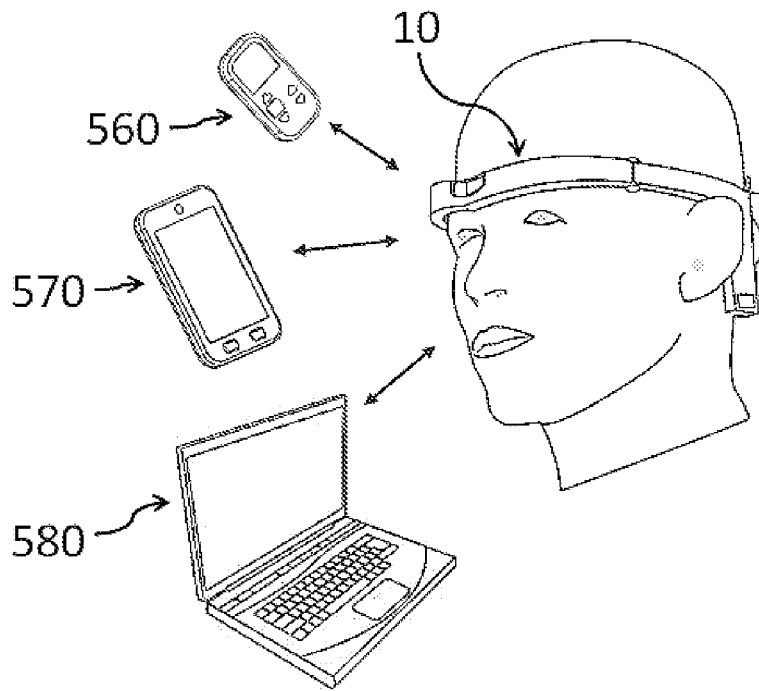

Fig. 36

REFERENCES CITED IN THE DESCRIPTION

This list of references cited by the applicant is for the reader's convenience only. It does not form part of the European patent document. Even though great care has been taken in compiling the references, errors or omissions cannot be excluded and the EPO disclaims all liability in this regard.

Patent documents cited in the description

- WO 2012079778 A [0046]

专利名称(译)	用于治疗 and 评估医疗状况的耳机		
公开(公告)号	EP2981326A4	公开(公告)日	2017-03-01
申请号	EP2014764750	申请日	2014-03-15
[标]申请(专利权)人(译)	纽洛利夫有限公司		
申请(专利权)人(译)	NEUROLIEF LTD.		
当前申请(专利权)人(译)	NEUROLIEF LTD.		
[标]发明人	DAR AMIT BAR OR JONATHAN COHEN AMIR BELSON RON		
发明人	DAR, AMIT BAR-OR, JONATHAN COHEN, AMIR BELSON, RON		
IPC分类号	A61N1/04 A61N1/18 A61N1/36 A61F5/34 A61B5/00 A61B5/0478		
CPC分类号	A61B5/0478 A61B5/6803 A61N1/0484 A61N1/0492 A61N1/36014 A61N1/3603 A61N1/0476 A61N1/0488		
优先权	61/786701 2013-03-15 US		
其他公开文献	EP2981326B1 EP2981326A1		
外部链接	Espacenet		

摘要(译)

一种圆周耳机，用于将电刺激传递到头部的皮肤表面。