



(11) **EP 2 211 767 B1**

(12) **EUROPEAN PATENT SPECIFICATION**

(45) Date of publication and mention of the grant of the patent:
12.12.2018 Bulletin 2018/50

(21) Application number: **08838487.0**

(22) Date of filing: **10.10.2008**

(51) Int Cl.:
A61F 2/00 ^(2006.01) **A61B 5/02** ^(2006.01)
A61B 17/12 ^(2006.01) **A61B 5/00** ^(2006.01)
A61B 5/07 ^(2006.01) **A61B 17/135** ^(2006.01)
A61B 17/00 ^(2006.01) **A61F 2/04** ^(2013.01)

(86) International application number:
PCT/SE2008/000560

(87) International publication number:
WO 2009/048373 (16.04.2009 Gazette 2009/16)

(54) **IMPLANTABLE DEVICE FOR EXTERNAL URINARY CONTROL**

IMPLANTIERBARE VORRICHTUNG ZUR EXTERNEN HARNWEGSKONTROLLE

DISPOSITIF IMPLANTABLE PERMETTANT DE MAÎTRISER LA MICTION DE FAÇON EXTERNE

(84) Designated Contracting States:
AT BE BG CH CY CZ DE DK EE ES FI FR GB GR HR HU IE IS IT LI LT LU LV MC MT NL NO PL PT RO SE SI SK TR

(30) Priority: **11.10.2007 US 960715 P**
11.10.2007 US 960716 P

(43) Date of publication of application:
04.08.2010 Bulletin 2010/31

(73) Proprietor: **Kirk Promotion LTD.**
114 79 Stockholm (SE)

(72) Inventor: **FORSELL, Peter**
6300 Zug (CH)

(56) References cited:
WO-A2-01/45486 **JP-A- 2006 136 416**
US-A- 5 123 428 **US-A- 5 876 425**
US-A1- 2003 060 893 **US-A1- 2003 125 768**
US-A1- 2004 242 956 **US-A1- 2005 266 042**
US-A1- 2006 041 309

EP 2 211 767 B1

Note: Within nine months of the publication of the mention of the grant of the European patent in the European Patent Bulletin, any person may give notice to the European Patent Office of opposition to that patent, in accordance with the Implementing Regulations. Notice of opposition shall not be deemed to have been filed until the opposition fee has been paid. (Art. 99(1) European Patent Convention).

Description

Field of invention

[0001] The present invention relates to an implantable apparatus for obtaining urinary control and emptying of the urinary bladder, thereby preventing from or treating involuntary urinary retention. More particularly, the invention relates to an implantable apparatus for discharging urine from the urinary bladder with a powered member operating from the outside of the urinary bladder assisted by a support structure.

Background of invention

[0002] Urinary dysfunction commonly caused by spinal cord injuries involves involuntary urinary retention, a condition which associated with urinary infections, renal damages or damages to the urinary tract. A common treatment of urinary retention is continuous or intermittent catheterization. Besides the inconvenience for the patient, catheters always represent a risk of acquiring infections. Alternatively suggested therapies include electric stimulation of the urinary bladder for providing muscle contraction and bladder emptying (see e.g. US Patent 6,393,323). Electric stimulation of the bladder needs consideration to that the urinary sphincter is stimulated to contraction by electricity and pulsed stimulation will become necessary which, however, may lead to uncontrolled squirts of urine through the urethra. It is obvious that there is a need for devices assisting with urinary bladder voiding which are efficient, reliable and that provide a high level of patient compliance. US 2004/242956 discloses a device that can increase the pressure in the urinary bladder with a constrictive jacket of mesh material comprising filaments of an electroactive polymer which by means of transducers can reduce or expand the jacket volume in order to expel or collect urine. However, the device is captured to have difficulties to fully and controllably empty the urinary bladder, as is required to prevent from urinary retention. For this reason, the present invention introduces improvements in the treatment of urinary retention.

Description of invention

[0003] In general terms, the present invention relates to an apparatus for treating urinary retention of a mammal patient, comprising an implantable powered member adapted exert a force from the outside on a selected part of the urinary bladder in order to discharge urine from the urinary bladder. The apparatus further comprises a control device for controlling the operation of the powered member. The force of the powered member is exerted at least partly against a support structure which is adapted to support against at least one of, a bone, such as the pelvic bone, pubic bone or sacrum or spinal cord, other human tissue such as peritoneum, the abdominal or pel-

vic wall or the urine bladder itself.

The control device preferably comprises a source of energy for operating the powered member and other energy consuming parts of the apparatus. Arrangements for energizing and controlling the apparatus in the context of a system comprising the apparatus will be disclosed below. The control device preferably is adapted to be implanted at least partly subcutaneously or in the abdomen or in the pelvic region. The control device comprises a control assembly adapted to be implanted both subcutaneously and/or in the abdominal cavity, said control assembly comprising at least two parts adapted to be connected, when implanted.

[0004] In order to actuate the urinary bladder from the outside, the powered member comprises a contacting part adapted to contact a surface part of the urinary bladder. The powered member comprises at least one operable pressurizer connected to the contacting part in an arrangement, wherein operating the pressurizer provides compression or release of the urinary bladder. For this purpose, the powered member can be hydraulically or mechanically operated to provide compression or release of the urinary bladder.

[0005] In one embodiment, the pressurizer comprises at least one movable arm extending from an operation device to the contacting part of the powered member. The operation device is adapted to displace the movable arm towards the urinary bladder in order to discharge urine from the urinary bladder. The operation device is fixated to human tissue, preferably in this embodiment, to the pubic bone. Further in this embodiment, the operation device comprises a motor, preferably an electric motor adapted to displace the movable arm. The contacting part is adapted be fixated to the upper part of urinary bladder and the contacting part preferably is designed to extend radially from a point essentially in line with the urinary bladder apex.

[0006] In another embodiment, the pressurizer comprises a reservoir for hydraulic fluid, and the contacting part comprises an expandable cavity hydraulically connected to the reservoir. The pressurizer comprises a pump for transporting the hydraulic fluid from the reservoir to expand the expandable cavity thereby compressing the urinary bladder. Further, the pressurizer is adapted to have the hydraulic fluid transported from the expandable cavity to the reservoir by the urinary pressure in the urinary bladder, when the pump is not active. In order to accomplish transportation back from the cavity to the reservoir, an arrangement can be provided wherein a second connection between the expandable cavity and the reservoir adapted to admit transportation hydraulic fluid from the expandable cavity to the reservoir by the urinary pressure in the urinary bladder, when the pump is not active. Preferably, the flow capacity of the second connection is smaller than the pump flow, allowing said second connection to stand open. Alternatively to this arrangement, the pump can transport hydraulic fluid from the expandable cavity to the reservoir in order to release

the urinary bladder.

[0007] In still another embodiment, the operable pressurizer comprises an operation device attached to a support device adapted to be fixated to the urinary bladder wall. The operable pressurizer comprises an actuator operably connected to the operation device comprising a motor to perform an actuating movement to actuate the contacting part to compress the urinary bladder. Preferably, the operation device comprises a pivot for accomplishing a pivotal movement of actuator. The support device is generally ring-shaped or having an intermittent ring-shape and extends along the periphery of the urinary bladder.

[0008] The apparatus as embodied in previous sections further can comprise a device for electrically stimulating the muscles of the urinary bladder to contract. Such a stimulating device can comprise a plurality of electrode strips attached to the muscles of the urinary bladder.

[0009] The apparatus as embodied in previous sections can also comprise an implantable pair of restriction devices, wherein the control device controls the restriction devices adapted to close the ureters when discharging urine from the urinary bladder.

[0010] The apparatus as embodied in previous sections can also comprise an artificial urinary sphincter, wherein a restriction device, controlled by the control device performs as a urinary sphincter.

[0011] The apparatus as embodied in previous sections can also comprise a sensor for measuring any parameter related to the urinary pressure or volume of the urinary bladder. The sensor is capable of sending a signal to the control device, which thereby activates and deactivates the powered member.

[0012] Also described is a method of implanting the disclosed apparatus that comprises the steps of inserting a needle-like tube into the abdomen of the patient; filling the abdomen with gas through said tube, thereby expanding the abdominal cavity; placing at least two laparoscopic trocars in the patient's body and inserting a camera through one of said trocars into the abdomen; inserting at least one dissecting tool through a trocar and dissecting an area of at least one portion of the urinary bladder of patient; fixating a first part of the powered member to the urinary bladder; fixating another, different part of the powered member to human tissue and implanting the control device connected to the powered member.

In the method the first part of the powered member is a contacting part contacting a surface part of the urinary bladder and the different part of the powered member is fixed to the pubic bone, or the abdominal wall, or the urinary bladder wall. When fixating the different part to the urinary wall it is preferred to tunnelling by suturing the urinary bladder wall to itself in order to immobilize the different part, while the urinary wall includes or not includes the peritoneum. Preferably, the different part comprises generally ring shaped support device which preferably extends along periphery of the urinary bladder.

[0013] Also describes is an alternative method for implanting the apparatus, comprises the steps of cutting the skin; dissecting an area of at least one portion of the urinary bladder of patient; fixating a first part of the powered member to the urinary bladder; fixating another, different part of the powered member to human tissue and implanting the control device connected to the powered member. In the method the first part of the powered member is a contacting part contacting a surface part of the urinary bladder and the different part of the powered member is fixed to the pubic bone, or the abdominal wall, or the urinary bladder wall; placing a control device outside the urinary bladder. The method further may include at least one of the following steps of placing a power source within the body, for powering the control device; placing a hydraulic reservoir and; placing a pump within the body, for pumping fluid between the reservoir and the expandable member to discharge urine from the urine bladder.

[0014] The present invention further relates to system comprising any of the previously disclosed embodiments of the apparatus including an implantable energy and In a preferred embodiment, the system comprises at least one switch implantable in the patient for manually and non-invasively controlling the apparatus

[0015] In another preferred embodiment, the system comprises a wireless remote control for non-invasively controlling the apparatus.

[0016] In a preferred embodiment, the system comprises a hydraulic operation device for operating the apparatus.

[0017] In one embodiment, the system comprises comprising a motor or a pump for operating the apparatus.

[0018] The apparatus or the system according to the invention can further comprise an energy-transforming device for transforming the wireless energy transmitted by the energy-transmission device from a first form into a second form of energy, wherein the energy-transforming device is adapted to perform at least one of the following; a) directly power implantable energy consuming components of the device with the second form of energy or b) when the system further comprising, an implantable internal energy source for powering implantable energy consuming components of the device, chargeable by the wireless energy, power the internal energy source with the second form of energy, as the energy-transforming device transforms the first form of energy transmitted by the energy-transmission device into the second form of energy.

[0019] The apparatus device or the system according to the invention, can further comprise a feedback device for sending feedback information from inside the patient's body to the outside thereof, the feedback information being related to at least one of a physical parameter of the patient and a functional parameter related to the device, wherein at least one functional parameter is correlated to the transfer of wireless energy.

[0020] The apparatus or the system according to the invention can further comprise a sensor and/or a measuring device and an implantable internal control unit for controlling the device in response to information being related to at least one of; a) a physical parameter of the patient sensed by the sensor or measured by the measuring device and b) a functional parameter related to the device sensed by the sensor or measured by the measuring device.

[0021] The apparatus or the system according to the invention can further comprise a control device for controlling the transmission of wireless energy from the energy-transmission device, and an implantable internal energy receiver for receiving the transmitted wireless energy, the internal energy receiver being connected to implantable energy consuming components of the device for directly or indirectly supplying received energy thereto, the system further comprising a determination device adapted to determine an energy balance between the energy received by the internal energy receiver and the energy used for the implantable energy consuming components of the device, wherein the control device controls the transmission of wireless energy from the external energy-transmission device, based on the energy balance determined by the determination device, wherein the determination device is adapted to detect at least one of; a) a change in the energy balance, and the control device controls the transmission of wireless energy based on the detected energy balance change, and b) a difference between energy received by the internal energy receiver and energy used for the implantable energy consuming components of the device, and the control device controls the transmission of wireless energy based on the detected energy difference.

[0022] The apparatus or the system according claim can further comprise implantable electrical components including at least one voltage level guard and/or at least one constant current guard.

[0023] The apparatus device or the system according to the invention can further comprise an external data communicator and an implantable internal data communicator communicating with the external data communicator, wherein the internal communicator feeds data related to the device or the patient to the external data communicator and/or the external data communicator feeds data to the internal data communicator.

[0024] Further details of the systems applicable with the apparatus as generally described herein are outlined below in the detailed description.

Detailed description of invention

[0025] The present invention will now be described in more detail by way of non-limiting examples and with reference to the accompanying drawings, in which:

Fig. 1 shows a schematic crosssectional view of an embodiment of the apparatus of invention when im-

planted in a patient.

Figs. 2 and 3 schematically show an embodiment of the apparatus with a first variant of the powered member.

Figs 4 and 5A to C schematically show respectively different embodiments of the pressurizer of the powered member.

Fig. 6 illustrates a system including an apparatus for treating urinary incontinence according to invention as generally described or illustrated in Figs. 1 to 5 here in a general form.

Figs. 7-21 schematically show various embodiments of the system for wirelessly powering the apparatus shown in Fig. 1.

Fig. 22 is a schematic block diagram illustrating an arrangement for supplying an accurate amount of energy used for the operation of the apparatus shown in Fig. 1.

Fig. 23 schematically shows an embodiment of the system, in which the apparatus is operated with wire bound energy.

Fig. 24 is a more detailed block diagram of an arrangement for controlling the transmission of wireless energy used for the operation of the apparatus shown in Fig. 1.

Fig. 25 is a circuit for the arrangement shown in Fig. 19, according to a possible implementation example.

Figs. 26-32 show various ways of arranging hydraulic or pneumatic powering of an apparatus implanted in a patient.

DETAILED DESCRIPTION OF THE DRAWINGS

[0026] Fig. 1 is a general crosssectional view of the apparatus when implanted in a human patient. Referring to Fig. 2 an embodiment of the apparatus is shown as implanted when operating on a urinary bladder 300. The apparatus includes a powered member 100 and a control device 200. The controls device 200 controls the operation of the powered member and is capable of receiving a signal from a sensor 150 related to the volume in the urine bladder such as a pressure sensor or any sensor related to the wall of the urine bladder (not shown and to communicate out from the body an alarm signal. The sensor is connected to sensor control unit 205 of the control device 200. Several different types of input sensors may be used determining for example stretching or bending or pressure in the urine bladder wall or for example sensing volume or pressure inside the urine bladder.

Most likely these sensors is only indirect causing the bladder to be emptied by presenting an alarm for the patient informing that it is time to empty the bladder. Such an alarm may be generated audible or visually. A remote control 300 controlled from outside body of the patient in order to operate the powered member, such as a wireless remote control communicating with an internal control unit 203 or at least one implanted switch 204. The control device 200 also includes an energy source 201 for supplying energy consuming parts of the powered member with energy. The energy source can be wirelessly supplied from the outside from an energizer unit 400. For this purpose the control device is provided with an energy transforming device 202. The control device comprises an external part 200A which is provided a manually operated switch 201 A and with an injection port 201B for hydraulic fluids communicating with an internal reservoir 206. The control device further includes a motor/pump function. It is contemplated that the features related to hydraulic fluid is relevant for a hydraulic embodiment of Fig. 4 and the powered member 100 includes a pressurizer 140 and a urinary bladder contact part 120 which may be fixated to the urinary bladder. The pressurizer includes an operation device 144 fixated to human tissue in this case the pubic bone and is operative connected to movable arm 142 connected to the contacting part. In operation to exert a pressure on the urinary bladder and thereby discharging urine through the urethra, the operation device 144 is activated by control device to move the arm towards the urinary bladder which thereby is contracted. Further Fig.2 shows a restriction device 59B for temporarily restriction of a ureter (this embodiment closes both ureters with restriction devices). The apparatus may eventually be provided with such restriction devices for the ureters which are controlled by the control device 200 to close the ureters when operating the powered member to discharge urine in order to prevent from a urinary flow from the bladder to the kidneys. In operation the control device 200 is activated and supplies the powered member with energy. The pressurizer will then actuate the urinary bladder to compress so the urinary pressure in the bladder is raise so urine is discharges through the urethra. When the urinary discharge is finalized the pressurizer alleviates the urinary and returns to its initial position, while the restriction devices for the ureters are released and the urinary bladder can receive urine from the kidneys. Fig. 3 shows the same apparatus as Fig. 2 when discharging urine through urethra. For this purpose the urinary sphincter 59C is deactivated an open and the restriction device 59B. The apparatus needs to exert a considerable pressure (about 60-80 cm water pressure) to force urine out from the bladder and urine may thereby backflow through ureters 32A, 32B with potential risks for damaging the kidneys. To prevent from any such complications, the control device is provided with restriction devices 59A, 59B arranged to temporarily contract the ureters and close them during the operation of discharging urine. The urine pressure in the ureter is normally

around 50 cm water, however short term pressure increase is most likely not damaging the kidneys and therefore the restriction devices 59A and 59B may be omitted.

[0027] Fig. 4 shows schematically a variant of the pressurizer which now includes reservoir 440 that is hydraulically connected to a cavity 420 of the contacting part. A control device 200 controls the operation of the pressurizer in a similar way as explained with Fig. 2. When operating the apparatus to discharge urine the control device activates transportation of fluid from the reservoir 440 to the cavity 420 of the contacting part which thereby expands in volume so the urinary bladder compresses and urine is discharge through the urethra as a consequence of a raised urinary pressure in the bladder. In order to release the bladder, fluid is transported back to the reservoir from the cavity. The back transportation can either be performed by a powered operation (i.e. a pump operatively connected to the reservoir) or as result of the raising urinary pressure in the bladder. A second connection 444 between the cavity and the reservoir is used for the later transport. If the pump pumping capacity is larger than the flow capacity of said second connection the second connection may be opened all the time. Fig. 4 further sows a sensor 445 communicating with control device sensor control unit. Fig. 5 shows schematically another variant of the pressurizer 540 including an operation device 544 attached to a support device 510 fixated to the urinary bladder wall. The pressurizer may be both hydraulically or mechanically operated. In this case a mechanical construction has an actuator 542 operably connected to the operation device to perform an actuating movement to actuate the contacting part 520 to compress the urinary bladder. In operation to discharge urine, the operation device performs a pivotal movement of the actuator so it contacts the contact part 520 to compress the urinary bladder in order to discharge urine through the urethra. When releasing the bladder the operation device removes the actuator 542 from the contacting part 520 to its initial position and the urinary bladder is ready to receive urine through the ureters.

[0028] Fig 5a shows an embodiment of the apparatus of Fig 2 with the operation device 544A placed on the abdominal wall as an alternative support function. Fig 5b shows another alternative of the apparatus of Fig. 2 with the operation device supported another bone structure. Fig 5c shows an alternative of the apparatus of Fig. 2 without restriction devices for the ureters and without a urinary sphincter function.

Some patients having urinary retention also have urinary incontinence. In such a case a separate urinary sphincter 59C is included in the system, a restriction device closing the urethra until the patient wants to urinate. In such a case lower pressure is needed to empty the bladder because the no force would be needed to open the sphincter by intra bladder pressure. In this case the ureter restriction devices may be omitted.

The reservoir may be placed anywhere inside the body, however preferable in the abdominal cavity, maybe

placed onto the urine bladder or in the pelvic region. The amount of liquid in the reservoir may be calibrated with fluid by using an injection port placed inside the body within reach from a special injection port needle. The reservoir may also be omitted and only the injection port may be used to fill and empty the expandable member.

[0029] Fig. 6 illustrates a system for treating urinary retention with an apparatus 10 of the present invention schematically shown placed in the abdomen of a patient. The apparatus 10 can be any of those discussed in the context of Figs. 1-5 or as generally described in previous section of the description. An implanted energy-transforming device 1002 is adapted to supply energy consuming components of the apparatus with energy via a power supply line 1003. An external energy-transmission device 1004 for non-invasively energizing the apparatus 10 transmits energy by at least one wireless energy signal. The implanted energy-transforming device 1002 transforms energy from the wireless energy signal into electric energy which is supplied via the power supply line 1003.

[0030] The wireless energy signal may include a wave signal selected from the following: a sound wave signal, an ultrasound wave signal, an electromagnetic wave signal, an infrared light signal, a visible light signal, an ultra violet light signal, a laser light signal, a micro wave signal, a radio wave signal, an x-ray radiation signal and a gamma radiation signal. Alternatively, the wireless energy signal may include an electric or magnetic field, or a combined electric and magnetic field.

[0031] The wireless energy-transmission device 1004 may transmit a carrier signal for carrying the wireless energy signal. Such a carrier signal may include digital, analogue or a combination of digital and analogue signals. In this case, the wireless energy signal includes an analogue or a digital signal, or a combination of an analogue and digital signal.

[0032] Generally speaking, the energy-transforming device 1002 is provided for transforming wireless energy of a first form transmitted by the energy-transmission device 1004 into energy of a second form, which typically is different from the energy of the first form. The implanted apparatus 10 is operable in response to the energy of the second form. The energy-transforming device 1002 may directly power the apparatus with the second form energy, as the energy-transforming device 1002 transforms the first form energy transmitted by the energy-transmission device 1004 into the second form energy. The system may further include an implantable accumulator, wherein the second form energy is used at least partly to charge the accumulator.

[0033] Alternatively, the wireless energy transmitted by the energy-transmission device 1004 may be used to directly power the apparatus, as the wireless energy is being transmitted by the energy-transmission device 1004. Where the system comprises an operation device for operating the apparatus, as will be described below, the wireless energy transmitted by the energy-transmis-

sion device 1004 may be used to directly power the operation device to create kinetic energy for the operation of the apparatus.

[0034] The wireless energy of the first form may comprise sound waves and the energy-transforming device 1002 may include a piezo-electric element for transforming the sound waves into electric energy. The energy of the second form may comprise electric energy in the form of a direct current or pulsating direct current, or a combination of a direct current and pulsating direct current, or an alternating current or a combination of a direct and alternating current. Normally, the apparatus comprises electric components that are energized with electrical energy. Other implantable electric components of the system may be at least one voltage level guard or at least one constant current guard connected with the electric components of the apparatus.

[0035] Optionally, one of the energy of the first form and the energy of the second form may comprise magnetic energy, kinetic energy, sound energy, chemical energy, radiant energy, electromagnetic energy, photo energy, nuclear energy or thermal energy. Preferably, one of the energy of the first form and the energy of the second form is non-magnetic, non-kinetic, non-chemical, non-sonic, non-nuclear or non-thermal.

[0036] The energy-transmission device may be controlled from outside the patient's body to release electromagnetic wireless energy, and the released electromagnetic wireless energy is used for operating the apparatus. Alternatively, the energy-transmission device is controlled from outside the patient's body to release non-magnetic wireless energy, and the released non-magnetic wireless energy is used for operating the apparatus.

[0037] The external energy-transmission device 1004 also includes a wireless remote control having an external signal transmitter for transmitting a wireless control signal for non-invasively controlling the apparatus. The control signal is received by an implanted signal receiver which may be incorporated in the implanted energy-transforming device 1002 or be separate there from.

[0038] The wireless control signal may include a frequency, amplitude, or phase modulated signal or a combination thereof. Alternatively, the wireless control signal includes an analogue or a digital signal, or a combination of an analogue and digital signal. Alternatively, the wireless control signal comprises an electric or magnetic field, or a combined electric and magnetic field.

[0039] The wireless remote control may transmit a carrier signal for carrying the wireless control signal. Such a carrier signal may include digital, analogue or a combination of digital and analogue signals. Where the control signal includes an analogue or a digital signal, or a combination of an analogue and digital signal, the wireless remote control preferably transmits an electromagnetic carrier wave signal for carrying the digital or analogue control signals.

[0040] Fig. 7 illustrates the system of Fig. 6 in the form of a more generalized block diagram showing the appa-

ratus 10, the energy-transforming device 1002 powering the apparatus 10 via power supply line 1003, and the external energy-transmission device 1004. The patient's skin 1005, generally shown by a vertical line, separates the interior of the patient to the right of the line from the exterior to the left of the line.

[0041] Fig. 8 shows an embodiment of the invention identical to that of Fig. 7, except that a reversing device in the form of an electric switch 1006 operable for example by polarized energy also is implanted in the patient for reversing the apparatus 10. When the switch is operated by polarized energy the wireless remote control of the external energy-transmission device 1004 transmits a wireless signal that carries polarized energy and the implanted energy-transforming device 1002 transforms the wireless polarized energy into a polarized current for operating the electric switch 1006. When the polarity of the current is shifted by the implanted energy-transforming device 1002 the electric switch 1006 reverses the function performed by the apparatus 10.

[0042] Fig. 9 shows an embodiment of the invention identical to that of Fig. 7, except that an operation device 1007 implanted in the patient for operating the apparatus 10 is provided between the implanted energy-transforming device 1002 and the apparatus 10. This operation device can be in the form of a motor 1007, such as an electric servomotor. The motor 1007 is powered with energy from the implanted energy-transforming device 1002, as the remote control of the external energy-transmission device 1004 transmits a wireless signal to the receiver of the implanted energy-transforming device 1002.

[0043] Fig. 10 shows an embodiment of the invention identical to that of Fig. 7, except that it also comprises an operation device in the form of an assembly 1008 including a motor/pump unit 1009 and a fluid reservoir 1010 is implanted in the patient. In this case the apparatus 10 is hydraulically operated, i.e. hydraulic fluid is pumped by the motor/pump unit 1009 from the fluid reservoir 1010 through a conduit 1011 to the apparatus 10 to operate the apparatus, and hydraulic fluid is pumped by the motor/pump unit 1009 back from the apparatus 10 to the fluid reservoir 1010 to return the apparatus to a starting position. The implanted energy-transforming device 1002 transforms wireless energy into a current, for example a polarized current, for powering the motor/pump unit 1009 via an electric power supply line 1012.

[0044] Instead of a hydraulically operated apparatus 10, it is also envisaged that the operation device comprises a pneumatic operation device. In this case, the hydraulic fluid can be pressurized air to be used for regulation and the fluid reservoir is replaced by an air chamber.

[0045] In all of these embodiments the energy-transforming device 1002 may include a rechargeable accumulator like a battery or a capacitor to be charged by the wireless energy and supplies energy for any energy consuming part of the system.

[0046] As an alternative, the wireless remote control described above may be replaced by manual control of any implanted part to make contact with by the patient's hand most likely indirect, for example a press button placed under the skin.

[0047] Fig. 11 shows an embodiment of the invention comprising the external energy-transmission device 1004 with its wireless remote control, the apparatus 10, in this case hydraulically operated, and the implanted energy-transforming device 1002, and further comprising a hydraulic fluid reservoir 1013, a motor/pump unit 1009 and an reversing device in the form of a hydraulic valve shifting device 1014, all implanted in the patient. Of course the hydraulic operation could easily be performed by just changing the pumping direction and the hydraulic valve may therefore be omitted. The remote control may be a device separated from the external energy-transmission device or included in the same. The motor of the motor/pump unit 1009 is an electric motor. In response to a control signal from the wireless remote control of the external energy-transmission device 1004, the implanted energy-transforming device 1002 powers the motor/pump unit 1009 with energy from the energy carried by the control signal, whereby the motor/pump unit 1009 distributes hydraulic fluid between the hydraulic fluid reservoir 1013 and the apparatus 10. The remote control of the external energy-transmission device 1004 controls the hydraulic valve shifting device 1014 to shift the hydraulic fluid flow direction between one direction in which the fluid is pumped by the motor/pump unit 1009 from the hydraulic fluid reservoir 1013 to the apparatus 10 to operate the apparatus, and another opposite direction in which the fluid is pumped by the motor/pump unit 1009 back from the apparatus 10 to the hydraulic fluid reservoir 1013 to return the apparatus to a starting position.

[0048] Fig. 12 shows an embodiment of the invention comprising the external energy-transmission device 1004 with its wireless remote control, the apparatus 10, the implanted energy-transforming device 1002, an implanted internal control unit 1015 controlled by the wireless remote control of the external energy-transmission device 1004, an implanted accumulator 1016 and an implanted capacitor 1017. The internal control unit 1015 arranges storage of electric energy received from the implanted energy-transforming device 1002 in the accumulator 1016, which supplies energy to the apparatus 10. In response to a control signal from the wireless remote control of the external energy-transmission device 1004, the internal control unit 1015 either releases electric energy from the accumulator 1016 and transfers the released energy via power lines 1018 and 1019, or directly transfers electric energy from the implanted energy-transforming device 1002 via a power line 1020, the capacitor 1017, which stabilizes the electric current, a power line 1021 and the power line 1019, for the operation of the apparatus 10.

[0049] The internal control unit is preferably programmable from outside the patient's body. In a preferred em-

bodiment, the internal control unit is programmed to regulate the apparatus 10 according to a pre-programmed time-schedule or to input from any sensor sensing any possible physical parameter of the patient or any functional parameter of the system.

[0050] In accordance with an alternative, the capacitor 1017 in the embodiment of Fig. 12 may be omitted. In accordance with another alternative, the accumulator 1016 in this embodiment may be omitted.

[0051] Fig. 13 shows an example identical to that of Fig. 7, except that a battery 1022 for supplying energy for the operation of the apparatus 10 and an electric switch 1023 for switching the operation of the apparatus 10 also are implanted in the patient. The electric switch 1023 may be controlled by the remote control and may also be operated by the energy supplied by the implanted energy-transforming device 1002 to switch from an off mode, in which the battery 1022 is not in use, to an on mode, in which the battery 1022 supplies energy for the operation of the apparatus 10.

[0052] Fig. 14 shows an example identical to that of Fig. 13, except that an internal control unit 1015 controllable by the wireless remote control of the external energy-transmission device 1004 also is implanted in the patient. In this case, the electric switch 1023 is operated by the energy supplied by the implanted energy-transforming device 1002 to switch from an off mode, in which the wireless remote control is prevented from controlling the internal control unit 1015 and the battery is not in use, to a standby mode, in which the remote control is permitted to control the internal control unit 1015 to release electric energy from the battery 1022 for the operation of the apparatus 10.

[0053] Fig. 15 shows an example identical to that of Fig. 14, except that an accumulator 1016 is substituted for the battery 1022 and the implanted components are interconnected differently. In this case, the accumulator 1016 stores energy from the implanted energy-transforming device 1002. In response to a control signal from the wireless remote control of the external energy-transmission device 1004, the internal control unit 1015 controls the electric switch 1023 to switch from an off mode, in which the accumulator 1016 is not in use, to an on mode, in which the accumulator 1016 supplies energy for the operation of the apparatus 10. The accumulator may be combined with or replaced by a capacitor.

[0054] Fig. 16 shows an example identical to that of Fig. 15, except that a battery 1022 also is implanted in the patient and the implanted components are interconnected differently. In response to a control signal from the wireless remote control of the external energy-transmission device 1004, the internal control unit 1015 controls the accumulator 1016 to deliver energy for operating the electric switch 1023 to switch from an off mode, in which the battery 1022 is not in use, to an on mode, in which the battery 1022 supplies electric energy for the operation of the apparatus 10.

[0055] Alternatively, the electric switch 1023 may be

operated by energy supplied by the accumulator 1016 to switch from an off mode, in which the wireless remote control is prevented from controlling the battery 1022 to supply electric energy and is not in use, to a standby mode, in which the wireless remote control is permitted to control the battery 1022 to supply electric energy for the operation of the apparatus 10.

[0056] It should be understood that the switch 1023 and all other switches in this application should be interpreted in its broadest embodiment. This means a transistor, MCU, MCP, ASIC, FPGA or a DA converter or any other electronic component or circuit that may switch the power on and off. Preferably the switch is controlled from outside the body, or alternatively by an implanted internal control unit.

[0057] Fig. 17 shows an embodiment of the invention identical to the example of Fig. 13, except that a motor 1007, a mechanical reversing device in the form of a gear box 1024, and an internal control unit 1015 for controlling the gear box 1024 also are implanted in the patient. The internal control unit 1015 controls the gear box 1024 to reverse the function performed by the apparatus 10 (mechanically operated). Even simpler is to switch the direction of the motor electronically. The gear box interpreted in its broadest embodiment may stand for a servo arrangement saving force for the operation device in favour of longer stroke to act.

[0058] Fig. 18 shows an example identical to that of Fig. 24 except that the implanted components are interconnected differently. Thus, in this case the internal control unit 1015 is powered by the battery 1022 when the accumulator 1016, suitably a capacitor, activates the electric switch 1023 to switch to an on mode. When the electric switch 1023 is in its on mode the internal control unit 1015 is permitted to control the battery 1022 to supply, or not supply, energy for the operation of the apparatus 10.

[0059] Fig. 19 schematically shows conceivable combinations of implanted components of the apparatus for achieving various communication options. Basically, there are the apparatus 10, the internal control unit 1015, motor or pump unit 1009, and the external energy-transmission device 1004 including the external wireless remote control. As already described above the wireless remote control transmits a control signal which is received by the internal control unit 1015, which in turn controls the various implanted components of the apparatus.

[0060] A feedback device, preferably comprising a sensor or measuring device 1025, may be implanted in the patient for sensing a physical parameter of the patient. The physical parameter may be at least one selected from the group consisting of pressure, volume, diameter, stretching, elongation, extension, movement, bending, elasticity, muscle contraction, nerve impulse, body temperature, blood pressure, blood flow, heartbeats and breathing. The sensor may sense any of the above physical parameters. For example, the sensor may be a pres-

sure or motility sensor. Alternatively, the sensor 1025 may be arranged to sense a functional parameter. The functional parameter may be correlated to the transfer of energy for charging an implanted energy source and may further include at least one selected from the group of parameters consisting of; electricity, any electrical parameter, pressure, volume, diameter, stretch, elongation, extension, movement, bending, elasticity, temperature and flow.

[0061] The feedback may be sent to the internal control unit or out to an external control unit preferably via the internal control unit. Feedback may be sent out from the body via the energy transfer system or a separate communication system with receiver and transmitters.

[0062] The internal control unit 1015, or alternatively the external wireless remote control of the external energy-transmission device 1004, may control the apparatus 10 in response to signals from the sensor 1025. A transceiver may be combined with the sensor 1025 for sending information on the sensed physical parameter to the external wireless remote control. The wireless remote control may comprise a signal transmitter or transceiver and the internal control unit 1015 may comprise a signal receiver or transceiver. Alternatively, the wireless remote control may comprise a signal receiver or transceiver and the internal control unit 1015 may comprise a signal transmitter or transceiver. The above transceivers, transmitters and receivers may be used for sending information or data related to the apparatus 10 from inside the patient's body to the outside thereof.

[0063] Where the motor/pump unit 1009 and battery 1022 for powering the motor/pump unit 1009 are implanted, information related to the charging of the battery 1022 may be fed back. To be more precise, when charging a battery or accumulator with energy feed back information related to said charging process is sent and the energy supply is changed accordingly.

[0064] Fig. 20 shows an alternative embodiment wherein the apparatus 10 is regulated from outside the patient's body. The system 1000 comprises a battery 1022 connected to the apparatus 10 via a subcutaneous electric switch 1026. Thus, the regulation of the apparatus 10 is performed non-invasively by manually pressing the subcutaneous switch, whereby the operation of the apparatus 10 is switched on and off. It will be appreciated that the shown embodiment is a simplification and that additional components, such as an internal control unit or any other part disclosed in the present application can be added to the system. Two subcutaneous switches may also be used. In the preferred embodiment one implanted switch sends information to the internal control unit to perform a certain predetermined performance and when the patient press the switch again the performance is reversed.

[0065] Fig. 21 shows an alternative embodiment, wherein the system 1000 comprises a hydraulic fluid reservoir 1013 hydraulically connected to the apparatus. Non-invasive regulation is performed by manually press-

ing the hydraulic reservoir connected to the apparatus.

[0066] The system may include an external data communicator and an implantable internal data communicator communicating with the external data communicator.

5 The internal communicator feeds data related to the apparatus or the patient to the external data communicator and/or the external data communicator feeds data to the internal data communicator.

[0067] Fig. 22 schematically illustrates an arrangement of the system that is capable of sending information from inside the patient's body to the outside thereof to give feedback information related to at least one functional parameter of the apparatus or system, or related to a physical parameter of the patient, in order to supply an accurate amount of energy to an implanted internal energy receiver 1002 connected to implanted energy consuming components of the apparatus 10. Such an energy receiver 1002 may include an energy source and/or an energy-transforming device. Briefly described, wireless energy is transmitted from an external energy source 1004a located outside the patient and is received by the internal energy receiver 1002 located inside the patient. The internal energy receiver is adapted to directly or indirectly supply received energy to the energy consuming components of the apparatus 10 via a switch 1026. An energy balance is determined between the energy received by the internal energy receiver 1002 and the energy used for the apparatus 10, and the transmission of wireless energy is then controlled based on the determined energy balance. The energy balance thus provides an accurate indication of the correct amount of energy needed, which is sufficient to operate the apparatus 10 properly, but without causing undue temperature rise.

35 **[0068]** In Fig. 22 the patient's skin is indicated by a vertical line 1005. Here, the energy receiver comprises an energy-transforming device 1002 located inside the patient, preferably just beneath the patient's skin 1005. Generally speaking, the implanted energy-transforming device 1002 may be placed in the abdomen, thorax, muscle fascia (e.g. in the abdominal wall), subcutaneously, or at any other suitable location. The implanted energy-transforming device 1002 is adapted to receive wireless energy E transmitted from the external energy-source 1004a provided in an external energy-transmission device 1004 located outside the patient's skin 1005 in the vicinity of the implanted energy-transforming device 1002.

[0069] As is well known in the art, the wireless energy E may generally be transferred by means of any suitable Transcutaneous Energy Transfer (TET) device, such as a device including a primary coil arranged in the external energy source 1004a and an adjacent secondary coil arranged in the implanted energy-transforming device 1002. When an electric current is fed through the primary coil, energy in the form of a voltage is induced in the secondary coil which can be used to power the implanted energy consuming components of the apparatus, e.g.

after storing the incoming energy in an implanted energy source, such as a rechargeable battery or a capacitor. However, the present invention is generally not limited to any particular energy transfer technique, TET devices or energy sources, and any kind of wireless energy may be used.

[0070] The amount of energy received by the implanted energy receiver may be compared with the energy used by the implanted components of the apparatus. The term "energy used" is then understood to include also energy stored by implanted components of the apparatus. A control device includes an external control unit 1004b that controls the external energy source 1004a based on the determined energy balance to regulate the amount of transferred energy. In order to transfer the correct amount of energy, the energy balance and the required amount of energy is determined by means of a determination device including an implanted internal control unit 1015 connected between the switch 1026 and the apparatus 10. The internal control unit 1015 may thus be arranged to receive various measurements obtained by suitable sensors or the like, not shown, measuring certain characteristics of the apparatus 10, somehow reflecting the required amount of energy needed for proper operation of the apparatus 10. Moreover, the current condition of the patient may also be detected by means of suitable measuring devices or sensors, in order to provide parameters reflecting the patient's condition. Hence, such characteristics and/or parameters may be related to the current state of the apparatus 10, such as power consumption, operational mode and temperature, as well as the patient's condition reflected by parameters such as; body temperature, blood pressure, heartbeats and breathing. Other kinds of physical parameters of the patient and functional parameters of the device are described elsewhere.

[0071] Furthermore, an energy source in the form of an accumulator 1016 may optionally be connected to the implanted energy-transforming device 1002 via the control unit 1015 for accumulating received energy for later use by the apparatus 10. Alternatively or additionally, characteristics of such an accumulator, also reflecting the required amount of energy, may be measured as well. The accumulator may be replaced by a rechargeable battery, and the measured characteristics may be related to the current state of the battery, any electrical parameter such as energy consumption voltage, temperature, etc. In order to provide sufficient voltage and current to the apparatus 10, and also to avoid excessive heating, it is clearly understood that the battery should be charged optimally by receiving a correct amount of energy from the implanted energy-transforming device 1002, i.e. not too little or too much. The accumulator may also be a capacitor with corresponding characteristics.

[0072] For example, battery characteristics may be measured on a regular basis to determine the current state of the battery, which then may be stored as state information in a suitable storage means in the internal

control unit 1015. Thus, whenever new measurements are made, the stored battery state information can be updated accordingly. In this way, the state of the battery can be "calibrated" by transferring a correct amount of energy, so as to maintain the battery in an optimal condition.

[0073] Thus, the internal control unit 1015 of the determination device is adapted to determine the energy balance and/or the currently required amount of energy, (either energy per time unit or accumulated energy) based on measurements made by the above-mentioned sensors or measuring devices of the apparatus 10, or the patient, or an implanted energy source if used, or any combination thereof. The internal control unit 1015 is further connected to an internal signal transmitter 1027, arranged to transmit a control signal reflecting the determined required amount of energy, to an external signal receiver 1004c connected to the external control unit 1004b. The amount of energy transmitted from the external energy source 1004a may then be regulated in response to the received control signal.

[0074] Alternatively, the determination device may include the external control unit 1004b. In this alternative, sensor measurements can be transmitted directly to the external control unit 1004b wherein the energy balance and/or the currently required amount of energy can be determined by the external control unit 1004b, thus integrating the above-described function of the internal control unit 1015 in the external control unit 1004b. In that case, the internal control unit 1015 can be omitted and the sensor measurements are supplied directly to the internal signal transmitter 1027 which sends the measurements over to the external signal receiver 1004c and the external control unit 1004b. The energy balance and the currently required amount of energy can then be determined by the external control unit 1004b based on those sensor measurements.

[0075] Hence, the present solution according to the arrangement of Fig. 22 employs the feed back of information indicating the required energy, which is more efficient than previous solutions because it is based on the actual use of energy that is compared to the received energy, e.g. with respect to the amount of energy, the energy difference, or the energy receiving rate as compared to the energy rate used by implanted energy consuming components of the apparatus. The apparatus may use the received energy either for consuming or for storing the energy in an implanted energy source or the like. The different parameters discussed above would thus be used if relevant and needed and then as a tool for determining the actual energy balance. However, such parameters may also be needed per se for any actions taken internally to specifically operate the apparatus.

[0076] The internal signal transmitter 1027 and the external signal receiver 1004c may be implemented as separate units using suitable signal transfer means, such as radio, IR (Infrared) or ultrasonic signals. Alternatively, the internal signal transmitter 1027 and the external signal

receiver 1004c may be integrated in the implanted energy-transforming device 1002 and the external energy source 1004a, respectively, so as to convey control signals in a reverse direction relative to the energy transfer, basically using the same transmission technique. The control signals may be modulated with respect to frequency, phase or amplitude.

[0077] Thus, the feedback information may be transferred either by a separate communication system including receivers and transmitters or may be integrated in the energy system. In accordance with the present invention, such an integrated information feedback and energy system comprises an implantable internal energy receiver for receiving wireless energy, the energy receiver having an internal first coil and a first electronic circuit connected to the first coil, and an external energy transmitter for transmitting wireless energy, the energy transmitter having an external second coil and a second electronic circuit connected to the second coil. The external second coil of the energy transmitter transmits wireless energy which is received by the first coil of the energy receiver. This system further comprises a power switch for switching the connection of the internal first coil to the first electronic circuit on and off, such that feedback information related to the charging of the first coil is received by the external energy transmitter in the form of an impedance variation in the load of the external second coil, when the power switch switches the connection of the internal first coil to the first electronic circuit on and off. In implementing this system in the arrangement of Fig. 17, the switch 1026 is either separate and controlled by the internal control unit 1015, or integrated in the internal control unit 1015. It should be understood that the switch 1026 should be interpreted in its broadest embodiment. This means a transistor, MCU, MCPU, ASIC FPGA or a DA converter or any other electronic component or circuit that may switch the power on and off.

[0078] To conclude, the energy supply arrangement illustrated in Fig. 22 may operate basically in the following manner. The energy balance is first determined by the internal control unit 1015 of the determination device. A control signal reflecting the required amount of energy is also created by the internal control unit 1015, and the control signal is transmitted from the internal signal transmitter 1027 to the external signal receiver 1004c. Alternatively, the energy balance can be determined by the external control unit 1004b instead depending on the implementation, as mentioned above. In that case, the control signal may carry measurement results from various sensors. The amount of energy emitted from the external energy source 1004a can then be regulated by the external control unit 1004b, based on the determined energy balance, e.g. in response to the received control signal. This process may be repeated intermittently at certain intervals during ongoing energy transfer, or may be executed on a more or less continuous basis during the energy transfer.

[0079] The amount of transferred energy can generally

be regulated by adjusting various transmission parameters in the external energy source 1004a, such as voltage, current, amplitude, wave frequency and pulse characteristics.

[0080] This system may also be used to obtain information about the coupling factors between the coils in a TET system even to calibrate the system both to find an optimal place for the external coil in relation to the internal coil and to optimize energy transfer. Simply comparing in this case the amount of energy transferred with the amount of energy received. For example if the external coil is moved the coupling factor may vary and correctly displayed movements could cause the external coil to find the optimal place for energy transfer. Preferably, the external coil is adapted to calibrate the amount of transferred energy to achieve the feedback information in the determination device, before the coupling factor is maximized.

[0081] This coupling factor information may also be used as a feedback during energy transfer. In such a case, the energy system of the present invention comprises an implantable internal energy receiver for receiving wireless energy, the energy receiver having an internal first coil and a first electronic circuit connected to the first coil, and an external energy transmitter for transmitting wireless energy, the energy transmitter having an external second coil and a second electronic circuit connected to the second coil. The external second coil of the energy transmitter transmits wireless energy which is received by the first coil of the energy receiver. This system further comprises a feedback device for communicating out the amount of energy received in the first coil as a feedback information, and wherein the second electronic circuit includes a determination device for receiving the feedback information and for comparing the amount of transferred energy by the second coil with the feedback information related to the amount of energy received in the first coil to obtain the coupling factor between the first and second coils. The energy transmitter may regulate the transmitted energy in response to the obtained coupling factor.

[0082] With reference to Fig. 23, although wireless transfer of energy for operating the apparatus has been described above to enable non-invasive operation, it will be appreciated that the apparatus can be operated with wire bound energy as well. Such an example is shown in Fig. 18, wherein an external switch 1026 is interconnected between the external energy source 1004a and an operation device, such as an electric motor 1007 operating the apparatus 10. An external control unit 1004b controls the operation of the external switch 1026 to effect proper operation of the apparatus 10.

[0083] Fig. 24 illustrates different embodiments for how received energy can be supplied to and used by the apparatus 10. Similar to the example of Fig. 17, an internal energy receiver 1002 receives wireless energy E from an external energy source 1004a which is controlled by a transmission control unit 1004b. The internal energy

receiver 1002 may comprise a constant voltage circuit, indicated as a dashed box "constant V" in the figure, for supplying energy at constant voltage to the apparatus 10. The internal energy receiver 1002 may further comprise a constant current circuit, indicated as a dashed box "constant C" in the figure, for supplying energy at constant current to the apparatus 10.

[0084] The apparatus 10 comprises an energy consuming part 10a, which may be a motor, pump, restriction device, or any other medical appliance that requires energy for its electrical operation. The apparatus 10 may further comprise an energy storage device 10b for storing energy supplied from the internal energy receiver 1002. Thus, the supplied energy may be directly consumed by the energy consuming part 10a, or stored by the energy storage device 10b, or the supplied energy may be partly consumed and partly stored. The apparatus 10 may further comprise an energy stabilizing unit 10c for stabilizing the energy supplied from the internal energy receiver 1002. Thus, the energy may be supplied in a fluctuating manner such that it may be necessary to stabilize the energy before consumed or stored.

[0085] The energy supplied from the internal energy receiver 1002 may further be accumulated and/or stabilized by a separate energy stabilizing unit 1028 located outside the apparatus 10, before being consumed and/or stored by the apparatus 10. Alternatively, the energy stabilizing unit 1028 may be integrated in the internal energy receiver 1002. In either case, the energy stabilizing unit 1028 may comprise a constant voltage circuit and/or a constant current circuit.

[0086] It should be noted that Fig. 22 and Fig. 24 illustrate some possible but non-limiting implementation options regarding how the various shown functional components and elements can be arranged and connected to each other. However, the skilled person will readily appreciate that many variations and modifications can be made within the scope of the present invention.

[0087] Fig. 25 schematically shows an energy balance measuring circuit of one of the proposed designs of the system for controlling transmission of wireless energy, or energy balance control system. The circuit has an output signal centered on 2.5V and proportionally related to the energy imbalance. The derivative of this signal shows if the value goes up and down and how fast such a change takes place. If the amount of received energy is lower than the energy used by implanted components of the apparatus, more energy is transferred and thus charged into the energy source. The output signal from the circuit is typically feed to an A/D converter and converted into a digital format. The digital information can then be sent to the external energy-transmission device allowing it to adjust the level of the transmitted energy. Another possibility is to have a completely analog system that uses comparators comparing the energy balance level with certain maximum and minimum thresholds sending information to external energy-transmission device if the balance drifts out of the max/min window.

[0088] The schematic Fig. 25 shows a circuit implementation for a system that transfers energy to the implanted energy components of the apparatus of the present invention from outside of the patient's body using inductive energy transfer. An inductive energy transfer system typically uses an external transmitting coil and an internal receiving coil. The receiving coil, L1, is included in the schematic Fig. 3; the transmitting parts of the system are excluded.

[0089] The implementation of the general concept of energy balance and the way the information is transmitted to the external energy transmitter can of course be implemented in numerous different ways. The schematic Fig. 25 and the above described method of evaluating and transmitting the information should only be regarded as examples of how to implement the control system.

CIRCUIT DETAILS

[0090] In Fig. 25 the symbols Y1, Y2, Y3 and so on symbolize test points within the circuit. The components in the diagram and their respective values are values that work in this particular implementation which of course is only one of an infinite number of possible design solutions.

[0091] Energy to power the circuit is received by the energy receiving coil L1. Energy to implanted components is transmitted in this particular case at a frequency of 25 kHz. The energy balance output signal is present at test point Y1.

[0092] Those skilled in the art will realize that the above various embodiments of the system could be combined in many different ways. For example, the electric switch 1006 of Fig. 8 could be incorporated in any of the embodiments of Figs. 11-17 the hydraulic valve shifting device 1014 of Fig. 11 could be incorporated in the embodiment of Fig. 10, and the gear box 1024 could be incorporated in the embodiment of Fig. 9. Please observe that the switch simply could mean any electronic circuit or component.

[0093] The embodiments described in connection with Figs. 22, 24 and 25 identify a method and a system for controlling transmission of wireless energy to implanted energy consuming components of an electrically operable apparatus. Such a method and system will be defined in general terms in the following.

[0094] A method is thus provided for controlling transmission of wireless energy supplied to implanted energy consuming components of an apparatus as described above. The wireless energy E is transmitted from an external energy source located outside the patient and is received by an internal energy receiver located inside the patient, the internal energy receiver being connected to the implanted energy consuming components of the apparatus for directly or indirectly supplying received energy thereto. An energy balance is determined between the energy received by the internal energy receiver and the energy used for the apparatus. The transmission of

wireless energy E from the external energy source is then controlled based on the determined energy balance.

[0095] The wireless energy may be transmitted inductively from a primary coil in the external energy source to a secondary coil in the internal energy receiver. A change in the energy balance may be detected to control the transmission of wireless energy based on the detected energy balance change. A difference may also be detected between energy received by the internal energy receiver and energy used for the medical device, to control the transmission of wireless energy based on the detected energy difference.

[0096] When controlling the energy transmission, the amount of transmitted wireless energy may be decreased if the detected energy balance change implies that the energy balance is increasing, or vice versa. The decrease/increase of energy transmission may further correspond to a detected change rate.

[0097] The amount of transmitted wireless energy may further be decreased if the detected energy difference implies that the received energy is greater than the used energy, or vice versa. The decrease/increase of energy transmission may then correspond to the magnitude of the detected energy difference.

[0098] As mentioned above, the energy used for the medical device may be consumed to operate the medical device, and/or stored in at least one energy storage device of the medical device.

[0099] When electrical and/or physical parameters of the medical device and/or physical parameters of the patient are determined, the energy may be transmitted for consumption and storage according to a transmission rate per time unit which is determined based on said parameters. The total amount of transmitted energy may also be determined based on said parameters.

[0100] When a difference is detected between the total amount of energy received by the internal energy receiver and the total amount of consumed and/or stored energy, and the detected difference is related to the integral over time of at least one measured electrical parameter related to said energy balance, the integral may be determined for a monitored voltage and/or current related to the energy balance.

[0101] When the derivative is determined over time of a measured electrical parameter related to the amount of consumed and/or stored energy, the derivative may be determined for a monitored voltage and/or current related to the energy balance.

[0102] The transmission of wireless energy from the external energy source may be controlled by applying to the external energy source electrical pulses from a first electric circuit to transmit the wireless energy, the electrical pulses having leading and trailing edges, varying the lengths of first time intervals between successive leading and trailing edges of the electrical pulses and/or the lengths of second time intervals between successive trailing and leading edges of the electrical pulses, and transmitting wireless energy, the transmitted energy gen-

erated from the electrical pulses having a varied power, the varying of the power depending on the lengths of the first and/or second time intervals.

[0103] In that case, the frequency of the electrical pulses may be substantially constant when varying the first and/or second time intervals. When applying electrical pulses, the electrical pulses may remain unchanged, except for varying the first and/or second time intervals. The amplitude of the electrical pulses may be substantially constant when varying the first and/or second time intervals. Further, the electrical pulses may be varied by only varying the lengths of first time intervals between successive leading and trailing edges of the electrical pulses.

[0104] A train of two or more electrical pulses may be supplied in a row, wherein when applying the train of pulses, the train having a first electrical pulse at the start of the pulse train and having a second electrical pulse at the end of the pulse train, two or more pulse trains may be supplied in a row, wherein the lengths of the second time intervals between successive trailing edge of the second electrical pulse in a first pulse train and leading edge of the first electrical pulse of a second pulse train are varied.

[0105] When applying the electrical pulses, the electrical pulses may have a substantially constant current and a substantially constant voltage. The electrical pulses may also have a substantially constant current and a substantially constant voltage. Further, the electrical pulses may also have a substantially constant frequency. The electrical pulses within a pulse train may likewise have a substantially constant frequency.

[0106] The circuit formed by the first electric circuit and the external energy source may have a first characteristic time period or first time constant, and when effectively varying the transmitted energy, such frequency time period may be in the range of the first characteristic time period or time constant or shorter.

[0107] A system comprising an apparatus as described above is thus also provided for controlling transmission of wireless energy supplied to implanted energy consuming components of the apparatus. In its broadest sense, the system comprises a control device for controlling the transmission of wireless energy from an energy-transmission device, and an implantable internal energy receiver for receiving the transmitted wireless energy, the internal energy receiver being connected to implantable energy consuming components of the apparatus for directly or indirectly supplying received energy thereto. The system further comprises a determination device adapted to determine an energy balance between the energy received by the internal energy receiver and the energy used for the implantable energy consuming components of the apparatus, wherein the control device controls the transmission of wireless energy from the external energy-transmission device, based on the energy balance determined by the determination device.

[0108] Further, the system may comprise any of the

following:

- A primary coil in the external energy source adapted to transmit the wireless energy inductively to a secondary coil in the internal energy receiver. 5
- The determination device is adapted to detect a change in the energy balance, and the control device controls the transmission of wireless energy based on the detected energy balance change 10
- The determination device is adapted to detect a difference between energy received by the internal energy receiver and energy used for the implantable energy consuming components of the apparatus, and the control device controls the transmission of wireless energy based on the detected energy difference. 15
- The control device controls the external energy-transmission device to decrease the amount of transmitted wireless energy if the detected energy balance change implies that the energy balance is increasing, or vice versa, wherein the decrease/increase of energy transmission corresponds to a detected change rate. 20
- The control device controls the external energy-transmission device to decrease the amount of transmitted wireless energy if the detected energy difference implies that the received energy is greater than the used energy, or vice versa, wherein the decrease/increase of energy transmission corresponds to the magnitude of said detected energy difference. 25
- The energy used for the apparatus is consumed to operate the apparatus, and/or stored in at least one energy storage device of the apparatus. 30
- Where electrical and/or physical parameters of the apparatus and/or physical parameters of the patient are determined, the energy-transmission device transmits the energy for consumption and storage according to a transmission rate per time unit which is determined by the determination device based on said parameters. The determination device also determines the total amount of transmitted energy based on said parameters. 35
- When a difference is detected between the total amount of energy received by the internal energy receiver and the total amount of consumed and/or stored energy, and the detected difference is related to the integral over time of at least one measured electrical parameter related to the energy balance, the determination device determines the integral for a monitored voltage and/or current related to the en- 40

ergy balance.

- When the derivative is determined over time of a measured electrical parameter related to the amount of consumed and/or stored energy, the determination device determines the derivative for a monitored voltage and/or current related to the energy balance. 5
- The energy-transmission device comprises a coil placed externally to the human body, and an electric circuit is provided to power the external coil with electrical pulses to transmit the wireless energy. The electrical pulses have leading and trailing edges, and the electric circuit is adapted to vary first time intervals between successive leading and trailing edges and/or second time intervals between successive trailing and leading edges of the electrical pulses to vary the power of the transmitted wireless energy. As a result, the energy receiver receiving the transmitted wireless energy has a varied power. 10
- The electric circuit is adapted to deliver the electrical pulses to remain unchanged except varying the first and/or second time intervals. 15
- The electric circuit has a time constant and is adapted to vary the first and second time intervals only in the range of the first time constant, so that when the lengths of the first and/or second time intervals are varied, the transmitted power over the coil is varied. 20
- The electric circuit is adapted to deliver the electrical pulses to be varied by only varying the lengths of first time intervals between successive leading and trailing edges of the electrical pulses. 25
- The electric circuit is adapted to supplying a train of two or more electrical pulses in a row, said train having a first electrical pulse at the start of the pulse train and having a second electrical pulse at the end of the pulse train, and 30
- the lengths of the second time intervals between successive trailing edge of the second electrical pulse in a first pulse train and leading edge of the first electrical pulse of a second pulse train are varied by the first electronic circuit. 35
- The electric circuit is adapted to provide the electrical pulses as pulses having a substantially constant height and/or amplitude and/or intensity and/or voltage and/or current and/or frequency. 40
- The electric circuit has a time constant, and is adapted to vary the first and second time intervals only in the range of the first time constant, so that when the lengths of the first and/or second time intervals are varied, the transmitted power over the first coil are 45

varied.

- The electric circuit is adapted to provide the electrical pulses varying the lengths of the first and/or the second time intervals only within a range that includes the first time constant or that is located relatively close to the first time constant, compared to the magnitude of the first time constant.

[0109] Figs. 26-29 show in more detail block diagrams of four different ways of hydraulically or pneumatically powering an implanted apparatus according to the invention.

[0110] Fig. 26 shows a system as described above with. The system comprises an implanted apparatus 10 and further a separate regulation reservoir 1013, a one way pump 1009 and an alternate valve 1014.

[0111] Fig. 27 shows the apparatus 10 and a fluid reservoir 1013. By moving the wall of the regulation reservoir or changing the size of the same in any other different way, the adjustment of the apparatus may be performed without any valve, just free passage of fluid any time by moving the reservoir wall.

[0112] Fig. 28 shows the apparatus 10, a two way pump 1009 and the regulation reservoir 1013.

[0113] Fig. 29 shows a block diagram of a reversed servo system with a first closed system controlling a second closed system. The servo system comprises a regulation reservoir 1013 and a servo reservoir 1050. The servo reservoir 1050 mechanically controls an implanted apparatus 10 via a mechanical interconnection 1054. The apparatus has an expandable/contactable cavity. This cavity is preferably expanded or contracted by supplying hydraulic fluid from the larger adjustable reservoir 1052 in fluid connection with the apparatus 10. Alternatively, the cavity contains compressible gas, which can be compressed and expanded under the control of the servo reservoir 1050.

[0114] The servo reservoir 1050 can also be part of the apparatus itself.

[0115] In one embodiment, the regulation reservoir is placed subcutaneous under the patient's skin and is operated by pushing the outer surface thereof by means of a finger. This system is illustrated in Figs 30a-c. In Fig. 30a, a flexible subcutaneous regulation reservoir 1013 is shown connected to a bulge shaped servo reservoir 1050 by means of a conduit 1011. This bellow shaped servo reservoir 1050 is comprised in a flexible apparatus 10. In the state shown in Fig. 30a, the servo reservoir 1050 contains a minimum of fluid and most fluid is found in the regulation reservoir 1013. Due to the mechanical interconnection between the servo reservoir 1050 and the apparatus 10, the outer shape of the apparatus 10 is contracted, i.e., it occupies less than its maximum volume. This maximum volume is shown with dashed lines in the figure.

[0116] Fig. 30b shows a state wherein a user, such as the patient in with the apparatus is implanted, presses

the regulation reservoir 1013 so that fluid contained therein is brought to flow through the conduit 1011 and into the servo reservoir 1050, which, thanks to its bellow shape, expands longitudinally. This expansion in turn expands the apparatus 10 so that it occupies its maximum volume, thereby stretching the stomach wall (not shown), which it contacts.

[0117] The regulation reservoir 1013 is preferably provided with means 1013a for keeping its shape after compression. This means, which is schematically shown in the figure, will thus keep the apparatus 10 in a stretched position also when the user releases the regulation reservoir. In this way, the regulation reservoir essentially operates as an on/off switch for the system.

[0118] An alternative embodiment of hydraulic or pneumatic operation will now be described with reference to Figs. 31 and 32a-c. The block diagram shown in Fig. 31 comprises with a first closed system controlling a second closed system. The first system comprises a regulation reservoir 1013 and a servo reservoir 1050. The servo reservoir 1050 mechanically controls a larger adjustable reservoir 1052 via a mechanical interconnection 1054. An implanted apparatus 10 having an expandable/contactable cavity is in turn controlled by the larger adjustable reservoir 1052 by supply of hydraulic fluid from the larger adjustable reservoir 1052 in fluid connection with the apparatus 10.

[0119] An example of this embodiment will now be described with reference to Fig. 32a-c. Like in the previous embodiment, the regulation reservoir is placed subcutaneous under the patient's skin and is operated by pushing the outer surface thereof by means of a finger. The regulation reservoir 1013 is in fluid connection with a bellow shaped servo reservoir 1050 by means of a conduit 1011. In the first closed system 1013, 1011, 1050 shown in Fig. 31a, the servo reservoir 1050 contains a minimum of fluid and most fluid is found in the regulation reservoir 1013.

[0120] The servo reservoir 1050 is mechanically connected to a larger adjustable reservoir 1052, in this example also having a bellow shape but with a larger diameter than the servo reservoir 1050. The larger adjustable reservoir 1052 is in fluid connection with the apparatus 10. This means that when a user pushes the regulation reservoir 1013, thereby displacing fluid from the regulation reservoir 1013 to the servo reservoir 1050, the expansion of the servo reservoir 1050 will displace a larger volume of fluid from the larger adjustable reservoir 1052 to the apparatus 10. In other words, in this reversed servo, a small volume in the regulation reservoir is compressed with a higher force and this creates a movement of a larger total area with less force per area unit.

[0121] Like in the previous embodiment described above with reference to Figs. 30a-c, the regulation reservoir 1013 is preferably provided with means 1013a for keeping its shape after compression. This means, which is schematically shown in the figure, will thus keep the apparatus 10 in a stretched position also when the user releases the regulation reservoir. In this way, the regu-

lation reservoir essentially operates as an on/off switch for the system.

Claims

1. An apparatus adapted to treatment of urinary retention of a mammal patient by discharging urine from the urinary bladder, comprising:

an implantable powered member (100) with a urinary bladder surface contact part, said powered member is adapted to exert a force from the outside on a selected part of the urinary bladder in order to discharge urine from the urinary bladder;

a support structure adapted to support against at least one of, a bone or other human tissue, such as the pelvic bone, pubic bone or sacrum, other human tissue such as peritoneum, the abdominal or pelvic wall or the urine bladder itself; and

a control device (200) for controlling the operation of the powered member,

wherein the apparatus is **characterized in that** the force of the powered member exerted on the urinary bladder is at least partly exerted against the support structure when discharging urine from the urinary bladder.

2. An apparatus according to anyone of claims 1, wherein the control device, comprises a source of energy for operating the powered member and other energy consuming parts of the apparatus.

3. An apparatus according to anyone of claims 1-2, wherein said control device is adapted to be implanted at least partly subcutaneously or in the abdomen or in the pelvic region.

4. An apparatus according to anyone of claims 1-3, wherein the control device, comprises a control assembly adapted to be implanted both subcutaneously and in the abdominal cavity, said control assembly comprising at least two parts adapted to be connected, when implanted.

5. An apparatus according to anyone of claims 1-4, wherein the powered member comprises at least one operable pressurizer (140) connected to a contacting part in an arrangement, wherein operating the pressurizer provides compression or release of the urinary bladder.

6. An apparatus according to anyone of claims 1-5, wherein the powered member is hydraulically operated to provide compression or release of the urinary bladder.

7. An apparatus according to anyone of claims 1-5, wherein the powered member is mechanically operated to provide compression or release of the urinary bladder.

8. An apparatus according to claim 7, comprising at least one movable arm (142) extending from an operation device (144) to a contacting part (120) of the powered member adapted to contact a surface part of the urinary bladder, wherein the operation device (144) is adapted to displace the movable arm towards the urinary bladder in order to discharge urine from the urinary bladder, wherein the operation device (144) comprises a motor adapted to displace the movable arm.

9. An apparatus according to claim 5, wherein the pressurizer comprises a reservoir for hydraulic fluid, wherein the contacting part (120) is adapted to contact a surface part of the urinary bladder preferable the upper part of urinary bladder, and wherein the contacting part comprises an expandable cavity hydraulically connected to the reservoir.

10. An apparatus according to claim 8, wherein the operation device is (144) fixated to human tissue, wherein the operation device is adapted for fixation to the pubic bone.

11. An apparatus according to claim 9, wherein the pressurizer comprises a pump for transporting the hydraulic fluid from the reservoir to expand the expandable cavity, thereby compressing the urinary bladder.

12. An apparatus according to claim 11, wherein the pressurizer is adapted to have the hydraulic fluid transported from the expandable cavity to the reservoir by the urinary pressure in the urinary bladder, when the pump is not active.

13. An apparatus according to claim 5, wherein operable pressurizer comprises an operation device attached to a support device adapted to be fixated to the urinary bladder wall.

14. An apparatus according to claim 13, wherein the support device is generally ring-shaped or having an intermittent ring-shape, said support device extending along the periphery of the urinary bladder.

15. An apparatus according to anyone of claims 1-12, comprising an operation device to operate the powered member, wherein the operation device comprises at least one of; a) at least one motor, preferable comprising a servo designed to decrease the force needed for the motor to operate the device, instead the motor acting a longer way increasing the

- time for a determined action and b) at least one pump for operating the device, wherein the pump is adapted to operate a hydraulic operation device for operating the device
16. An apparatus according to anyone of claims 1-15, wherein the control device further comprises a device for electrically stimulating the muscles of the urinary bladder to contract the muscles.
17. An apparatus according to claim 16, wherein the electrically stimulating device comprises a plurality of electrodes attached to the muscles of the urinary bladder.
18. An apparatus according to anyone of claims 1-17, comprising an implantable pair of restriction devices, wherein the control device controls the restriction devices adapted to close the ureters when discharging urine from the urinary bladder.
19. An apparatus according to anyone of claims 1-18, comprising an artificial urinary sphincter, wherein a restriction device, controlled by the control device performs as a urinary sphincter.
20. An apparatus according anyone of claims 1-19, comprising a sensor for measuring any parameter related to the urinary pressure or volume of the urinary bladder, said sensor being capable of sending a signal to the control device, which thereby is adapted to send an alarm information out from the body as a request for activating the powered member.
21. An apparatus according to anyone of claims 1-20, further comprises at least one of the following; a) at least one switch implantable in the patient for manually and non-invasively controlling the device, b) a hydraulic device having an implantable hydraulic reservoir, which is hydraulically connected to the device, wherein the device is adapted to be non-invasively regulated by manually pressing the hydraulic reservoir, and c) a wireless remote control for non-invasively controlling the device.
22. A system comprising an apparatus according to any of claims 1-21, comprising an implantable internal energy source for powering implantable energy consuming components of the apparatus.
23. An apparatus according to any of claims 1-21, or a system according to claim 22, further comprising a wireless energy-transmission device for non-invasively energizing implantable energy consuming components of the device with wireless energy.
24. An apparatus according to any of claims 1-21, or a system according to claim 22 or 23, further comprising an energy-transforming device for transforming the wireless energy transmitted by the energy-transmission device from a first form into a second form of energy, wherein the energy-transforming device is adapted to perform at least one of the following; a) directly power implantable energy consuming components of the device with the second form of energy or b) when the system further comprising, an implantable internal energy source for powering implantable energy consuming components of the device, chargeable by the wireless energy, power the internal energy source with the second form of energy, as the energy-transforming device transforms the first form of energy transmitted by the energy-transmission device into the second form of energy.
25. An apparatus device according to any of claims 1-21, or a system according to claim 22, further comprising a feedback device for sending feedback information from inside the patient's body to the outside thereof, the feedback information being related to at least one of a physical parameter of the patient and a functional parameter related to the device, wherein at least one functional parameter is correlated to the transfer of wireless energy.
26. An apparatus according to any of claims 1-21, or a system according to claims 22, further comprising a sensor and/or a measuring device and an implantable internal control unit for controlling the device in response to information being related to at least one of; a) a physical parameter of the patient sensed by the sensor or measured by the measuring device and b) a functional parameter related to the device sensed by the sensor or measured by the measuring device.
27. An apparatus according to any of claims 1-21, or a system according to claim 22, further comprising a control device for controlling the transmission of wireless energy from the energy-transmission device, and an implantable internal energy receiver for receiving the transmitted wireless energy, the internal energy receiver being connected to implantable energy consuming components of the device for directly or indirectly supplying received energy thereto, the system further comprising a determination device adapted to determine an energy balance between the energy received by the internal energy receiver and the energy used for the implantable energy consuming components of the device, wherein the control device controls the transmission of wireless energy from the external energy-transmission device, based on the energy balance determined by the determination device, wherein the determination device is adapted to detect at least one of; a) a change in the energy balance, and the control device controls the transmission of wireless energy based

on the detected energy balance change, and b) a difference between energy received by the internal energy receiver and energy used for the implantable energy consuming components of the device, and the control device controls the transmission of wireless energy based on the detected energy difference.

28. An apparatus according to any of claims 1-21, or a system according claim 22, further comprising implantable electrical components including at least one voltage level guard and/or at least one constant current guard.

29. An apparatus device according to any of claims 1-21, or a system according to claim 22, further comprising an external data communicator and an implantable internal data communicator communicating with the external data communicator, wherein the internal communicator feeds data related to the device or the patient to the external data communicator and/or the external data communicator feeds data to the internal data communicator.

Patentansprüche

1. Vorrichtung, die zur Behandlung der Harnretention eines Säugetierpatienten durch die Ausscheidung von Urin aus der Harnblase eingerichtet ist, umfassend:

ein implantierbares angetriebenes Element (100) mit einem Harnblasenoberflächenkontaktteil, wobei das angetriebene Element eingerichtet ist, um eine Kraft von außen auf einen ausgewählten Teil der Harnblase auszuüben, um Urin aus der Harnblase auszuscheiden; eine Stützstruktur, die eingerichtet ist, um sich gegen mindestens eines von einem Knochen oder anderem menschlichen Gewebe, wie etwa dem Beckenknochen, dem Schambein oder dem Kreuzbein, einem anderen menschlichen Gewebe, wie etwa dem Bauchfell, der Bauch- oder Beckenwand oder der Urinblase selbst abzustützen; und eine Steuervorrichtung (200) zum Steuern des Betriebs des angetriebenen Elements, wobei die Vorrichtung **dadurch gekennzeichnet ist, dass** die Kraft des angetriebenen Elements, die auf die Harnblase ausgeübt wird, mindestens teilweise gegen die Stützstruktur ausgeübt wird, wenn Urin aus der Harnblase ausgeschieden wird.

2. Vorrichtung nach einem der Ansprüche 1, wobei die Steuervorrichtung eine Energiequelle zum Betreiben des angetriebenen Elements und anderer ener-

gieverbrauchender Teile der Vorrichtung aufweist.

3. Vorrichtung nach einem der Ansprüche 1 bis 2, wobei die Steuervorrichtung eingerichtet ist, mindestens teilweise subkutan oder in den Bauch- oder in den Beckenbereich implantiert zu werden.

4. Vorrichtung nach einem der Ansprüche 1 bis 3, wobei die Steuervorrichtung eine Steueranordnung umfasst, die eingerichtet ist, sowohl subkutan als auch in der Bauchhöhle implantiert zu werden, wobei die Steueranordnung mindestens zwei Teile umfasst, die eingerichtet sind, nach dem Implantieren verbunden zu werden.

5. Vorrichtung nach einem der Ansprüche 1 bis 4, wobei das angetriebene Element mindestens einen betreibbaren Druckhalter (140) umfasst, der mit einem Kontaktteil in einer Anordnung verbunden ist, wobei das Betreiben des Druckhalters eine Kompression oder Freisetzung der Harnblase bereitstellt.

6. Vorrichtung nach einem der Ansprüche 1 bis 5, wobei das angetriebene Element hydraulisch betätigt wird, um das Zusammendrücken oder Freigeben der Harnblase bereitzustellen.

7. Vorrichtung nach einem der Ansprüche 1 bis 5, wobei das angetriebene Element mechanisch betätigt wird, um das Zusammendrücken oder Freigeben der Harnblase bereitzustellen.

8. Vorrichtung nach Anspruch 7, umfassend mindestens einen beweglichen Arm (142), der sich von einer Betätigungsverrichtung (144) zu einem Kontaktteil (120) des angetriebenen Elements erstreckt, der eingerichtet ist, einen Oberflächenteil der Harnblase zu kontaktieren, wobei die Betätigungsverrichtung (144) eingerichtet ist, den beweglichen Arm in Richtung der Harnblase zu verschieben, um Urin aus der Harnblase auszuscheiden, wobei die Betätigungsverrichtung (144) einen Motor umfasst, der eingerichtet ist, den beweglichen Arm zu verschieben.

9. Vorrichtung nach Anspruch 5, wobei der Druckhalter einen Vorratsbehälter für Hydraulikfluid umfasst, wobei der Kontaktteil (120) eingerichtet ist, um einen Oberflächenteil der Harnblase zu kontaktieren, vorzugsweise den oberen Teil der Harnblase, und wobei der Kontaktteil einen expandierbaren Hohlraum umfasst, der hydraulisch mit dem Vorratsbehälter verbunden ist.

10. Vorrichtung nach Anspruch 8, wobei die Betätigungsverrichtung (144) an menschlichem Gewebe befestigt ist, wobei die Betätigungsverrichtung zur Befestigung am Schambein eingerichtet ist.

11. Vorrichtung nach Anspruch 9, wobei der Druckhalter eine Pumpe zum Transportieren des Hydraulikfluids aus dem Vorratsbehälter umfasst, um den ausdehnbaren Hohlraum auszudehnen, um dadurch die Harnblase zusammenzudrücken.
12. Vorrichtung nach Anspruch 11, wobei der Druckhalter eingerichtet ist, um das Hydraulikfluid durch den Harndruck in der Harnblase von dem ausdehnbaren Hohlraum zu dem Behälter transportieren zu lassen, wenn die Pumpe nicht aktiv ist.
13. Vorrichtung nach Anspruch 5, wobei der betätigbare Druckhalter eine Betätigungsvorrichtung umfasst, die an einer Stützvorrichtung befestigt ist, die eingerichtet ist, dass sie an der Harnblasenwand befestigt werden kann.
14. Vorrichtung nach Anspruch 13, wobei die Stützvorrichtung im Allgemeinen ringförmig ist oder eine intermittierende Ringform aufweist, wobei sich die Stützvorrichtung entlang des Umfangs der Harnblase erstreckt.
15. Vorrichtung nach einem der Ansprüche 1 bis 12, umfassend eine Betätigungsvorrichtung zum Betreiben des angetriebenen Elements, wobei die Betätigungsvorrichtung mindestens eines von a) mindestens einem Motor, vorzugsweise eine Servoeinrichtung aufweisend, die dazu konstruiert ist, die für den Motor zum Betreiben der Vorrichtung erforderliche Kraft zu verringern, anstatt den Motor länger arbeiten zu lassen, was die Zeit für eine bestimmte Aktion erhöht, und b) mindestens eine Pumpe zum Betreiben der Vorrichtung umfasst, wobei die Pumpe dazu eingerichtet ist, eine hydraulische Betätigungsvorrichtung zum Betätigen der Vorrichtung zu betreiben.
16. Vorrichtung nach einem der Ansprüche 1 bis 15, wobei die Steuervorrichtung ferner eine Vorrichtung zum elektrischen Stimulieren der Muskeln der Harnblase zum Zusammenziehen der Muskeln umfasst.
17. Vorrichtung nach Anspruch 16, wobei die elektrisch stimulierende Vorrichtung eine Vielzahl von Elektroden umfasst, die an den Muskeln der Harnblase angebracht sind.
18. Vorrichtung nach einem der Ansprüche 1 bis 17, umfassend ein implantierbares Paar von Restriktionseinrichtungen, wobei die Steuervorrichtung die Restriktionseinrichtungen steuert, die eingerichtet sind, um die Harnleiter zu schließen, wenn Urin aus der Harnblase ausgeschieden wird.
19. Vorrichtung nach einem der Ansprüche 1 bis 18, umfassend einen künstlichen Blasenschließmuskel, wobei eine durch die Steuervorrichtung gesteuerte Restriktionseinrichtung als Blasenschließmuskel wirkt.
20. Vorrichtung nach einem der Ansprüche 1 bis 19, umfassend einen Sensor zum Messen eines beliebigen Parameters, der mit dem Harndruck oder dem Volumen der Harnblase in Verbindung steht, wobei der Sensor in der Lage ist, ein Signal an die Steuervorrichtung zu senden, die dadurch eingerichtet ist, eine Alarminformation aus dem Körper als Anforderung zur Aktivierung des angetriebenen Elements zu senden.
21. Vorrichtung nach einem der Ansprüche 1 bis 20, die ferner mindestens eines der Folgenden umfasst: a) mindestens einen in den Patienten implantierbaren Schalter zum manuellen und nicht-invasiven Steuern der Vorrichtung, b) eine hydraulische Vorrichtung, die einen implantierbaren Hydraulik-Vorratsbehälter aufweist, der hydraulisch mit der Vorrichtung verbunden ist, wobei die Vorrichtung eingerichtet ist, durch manuelles Drücken des Hydraulik-Vorratsbehälters nicht-invasiv geregelt zu werden, und c) eine drahtlose Fernbedienung zum nicht-invasiven Steuern der Vorrichtung.
22. System, umfassend eine Vorrichtung nach einem der Ansprüche 1 bis 21, umfassend eine implantierbare interne Energiequelle zur Energieversorgung von implantierbaren energieverbrauchenden Komponenten der Vorrichtung.
23. Vorrichtung nach einem der Ansprüche 1 bis 21 oder einem System nach Anspruch 22, ferner umfassend eine drahtlose Energieübertragungsvorrichtung zur nicht-invasiven Speisung von implantierbaren energieverbrauchenden Komponenten der Vorrichtung mit drahtloser Energie.
24. Vorrichtung nach einem der Ansprüche 1 bis 21 oder einem System nach Anspruch 22 oder 23, ferner umfassend eine Energieumwandlungsvorrichtung zum Umwandeln der von der Energieumwandlungsvorrichtung übertragenen drahtlosen Energie von einer ersten Form in eine zweite Form von Energie, wobei die Energieumwandlungsvorrichtung eingerichtet ist, um mindestens eines der Folgenden durchzuführen; a) direktes Versorgen von implantierbaren energieverbrauchenden Komponenten der Vorrichtung mit der zweiten Energieform oder b) wenn das System ferner eine implantierbare interne Energiequelle zur Energieversorgung von implantierbaren energieverbrauchenden Komponenten der Vorrichtung, die durch die drahtlose Energie aufladbar ist, umfasst, die interne Energiequelle mit der zweiten Energieform zu versorgen, da die energieumwandelnde Vorrichtung die erste Form der von der En-

ergieübertragungsvorrichtung übertragenen Energie in die zweite Energieform umwandelt.

25. Geräteeinrichtung nach einem der Ansprüche 1 bis 21 oder einem System nach Anspruch 22, ferner umfassend eine Rückmeldeeinrichtung zum Senden von Rückmeldeinformationen aus dem Inneren des Körpers des Patienten nach der Außenseite davon, wobei sich die Rückmeldeinformationen auf mindestens einen der physikalischen Parameter des Patienten und einen mit der Vorrichtung zusammenhängenden funktionellen Parameter beziehen, wobei mindestens ein funktioneller Parameter mit der Übertragung von drahtloser Energie korreliert ist.
26. Vorrichtung nach einem der Ansprüche 1 bis 21 oder ein System nach Anspruch 22, ferner umfassend einen Sensor und/oder eine Messvorrichtung und eine implantierbare interne Steuereinheit zum Steuern der Vorrichtung in Reaktion auf Informationen, die mit mindestens einem von a) einem durch den Sensor erfassten oder durch die Messvorrichtung gemessenen physikalischen Parameter des Patienten und b) einem mit der Vorrichtung zusammenhängenden, durch den Sensor erfassten oder durch die Messvorrichtung gemessenen funktionellen Parameter in Zusammenhang stehen.
27. Vorrichtung nach einem der Ansprüche 1 bis 21 oder ein System nach Anspruch 22, ferner umfassend eine Steuervorrichtung zum Steuern der Übertragung von drahtloser Energie von der Energieübertragungsvorrichtung und einen implantierbaren internen Energieempfänger zum Empfangen der übertragenen drahtlosen Energie, wobei der interne Energieempfänger mit implantierbaren energieverbrauchenden Komponenten der Vorrichtung verbunden ist, um ihr direkt oder indirekt empfangene Energie zuzuführen, wobei das System ferner eine Bestimmungsvorrichtung umfasst, die eingerichtet ist, um eine Energiebilanz zwischen der von dem internen Energieempfänger empfangenen Energie und der Energie zu bestimmen, die für die implantierbaren energieverbrauchenden Komponenten der Vorrichtung verwendet wird, wobei die Steuervorrichtung die Übertragung von drahtloser Energie von der externen Energieübertragungsvorrichtung basierend auf der von der Bestimmungsvorrichtung bestimmten Energiebilanz steuert, wobei die Bestimmungsvorrichtung eingerichtet ist, um mindestens eines von; a) einer Änderung in der Energiebilanz, und die Steuervorrichtung steuert die Übertragung von drahtloser Energie basierend auf der erfassten Energiebilanzveränderung und b) eine Differenz zwischen der vom internen Energieempfänger empfangenen Energie und der Energie zu erfassen, die für die implantierbaren energieverbrauchenden Komponenten der Vorrichtung verwendet wird,

und die Steuervorrichtung steuert die Übertragung von drahtloser Energie basierend auf der erfassten Energiedifferenz.

- 5 28. Vorrichtung nach einem der Ansprüche 1 bis 21 oder ein System nach Anspruch 22, ferner umfassend implantierbare elektrische Komponenten, die mindestens einen Spannungspegelbegrenzer und/oder mindestens einen Konstantstrombegrenzer umfassen.
- 10 29. Geräteeinrichtung nach einem der Ansprüche 1 bis 21 oder ein System nach Anspruch 22, ferner umfassend einen externen Datenkommunikator und einen implantierbaren internen Datenkommunikator, der mit dem externen Datenkommunikator kommuniziert, wobei der interne Kommunikator dem externen Datenkommunikator die mit der Vorrichtung oder dem Patienten zusammenhängenden Daten zuführt, und/oder der externe Datenkommunikator dem internen Datenkommunikator Daten zuführt.
- 15 20 25

Revendications

1. Appareil adapté au traitement de la rétention urinaire d'un patient mammifère en déchargeant de l'urine de la vessie, comprenant :
- 30 un élément motorisé implantable (100) avec une partie de contact avec la surface de la vessie, ledit élément motorisé étant conçu pour exercer une force de l'extérieur sur une partie sélectionnée de la vessie afin de décharger l'urine de la vessie ;
- 35 une structure de support conçue pour supporter au moins un tissu osseux ou autre tissu humain, tel que l'os pelvien, l'os pubien ou le sacrum, d'autres tissus humains tels que le péritoine, la paroi abdominale ou pelvienne ou la vessie elle-même ; et
- 40 un dispositif de commande (200) pour commander le fonctionnement de l'élément motorisé, l'appareil étant **caractérisé en ce que** la force de l'élément motorisé exercée sur la vessie est exercée au moins partiellement contre la structure de support lors de la décharge de l'urine de la vessie.
- 45 50 2. Appareil selon l'une quelconque des revendications 1, dans lequel le dispositif de commande comprend une source d'énergie pour faire fonctionner l'élément motorisé et d'autres parties consommatrices d'énergie de l'appareil.
- 55 3. Appareil selon l'une quelconque des revendications 1 ou 2, dans lequel ledit dispositif de commande est conçu pour être implanté au moins partiellement par

- voie sous-cutanée ou dans l'abdomen ou dans la région pelvienne.
4. Appareil selon l'une quelconque des revendications 1 à 3, dans lequel le dispositif de commande comprend un ensemble de commande conçu pour être implanté à la fois par voie sous-cutanée et dans la cavité abdominale, ledit ensemble de commande comprenant au moins deux parties adaptées pour être reliées, lorsqu'elles sont implantées. 5
 5. Appareil selon l'une quelconque des revendications 1 à 4, dans lequel l'élément motorisé comprend au moins un pressuriseur pouvant être actionné (140), relié à une partie de contact dans un agencement, dans lequel le fonctionnement du pressuriseur assure la compression ou le relâchement de la vessie. 10
 6. Appareil selon l'une quelconque des revendications 1 à 5, dans lequel l'élément motorisé est actionné hydrauliquement pour assurer la compression ou le relâchement de la vessie. 15
 7. Appareil selon l'une quelconque des revendications 1 à 5, dans lequel l'élément motorisé est actionné mécaniquement pour assurer la compression ou le relâchement de la vessie. 20
 8. Appareil selon la revendication 7, comprenant au moins un bras mobile (142) s'étendant d'un dispositif d'actionnement (144) à une partie de contact (120) de l'élément motorisé conçu pour entrer en contact avec une partie de surface de la vessie, dans lequel le dispositif d'actionnement (144) est conçu pour déplacer le bras mobile vers la vessie afin de décharger l'urine de la vessie, dans lequel le dispositif d'actionnement (144) comprend un moteur en mesure de déplacer le bras mobile. 25
 9. Appareil selon la revendication 7, comprenant au moins un bras mobile (142) s'étendant d'un dispositif d'actionnement (144) à une partie de contact (120) de l'élément motorisé conçu pour entrer en contact avec une partie de surface de la vessie, dans lequel le dispositif d'actionnement (144) est conçu pour déplacer le bras mobile. 30
 10. Appareil selon la revendication 7, comprenant au moins un bras mobile (142) s'étendant d'un dispositif d'actionnement (144) à une partie de contact (120) de l'élément motorisé conçu pour entrer en contact avec une partie de surface de la vessie, dans lequel le dispositif d'actionnement (144) est conçu pour déplacer le bras mobile. 35
 11. Appareil selon la revendication 7, comprenant au moins un bras mobile (142) s'étendant d'un dispositif d'actionnement (144) à une partie de contact (120) de l'élément motorisé conçu pour entrer en contact avec une partie de surface de la vessie, dans lequel le dispositif d'actionnement (144) est conçu pour déplacer le bras mobile. 40
 12. Appareil selon la revendication 11, dans lequel le pressuriseur est conçu de sorte que le fluide hydraulique soit transporté de la cavité extensible vers le réservoir par la pression urinaire dans la vessie, lorsque la pompe n'est pas active. 45
 13. Appareil selon la revendication 5, dans lequel le pressuriseur opérationnel comprend un dispositif d'actionnement fixé à un dispositif de support conçu pour être fixé à la paroi de la vessie. 50
 14. Appareil selon la revendication 13, dans lequel le dispositif de support a généralement la forme d'un anneau ou la forme d'un anneau intermittent, ledit dispositif de support s'étendant le long de la périphérie de la vessie. 55
 15. Appareil selon l'une quelconque des revendications 1 à 12, comprenant un dispositif d'actionnement commande pour actionner l'élément motorisé, dans lequel le dispositif d'actionnement comprend au moins l'un des éléments suivants : a) au moins un moteur, comprenant de préférence un servomécanisme conçu pour diminuer la force nécessaire au moteur pour faire fonctionner le dispositif, sans lequel le moteur agit de manière plus lente, ce qui augmente le temps nécessaire à une action déterminée et b) au moins une pompe pour faire fonctionner le dispositif, dans lequel la pompe est conçue pour faire fonctionner un dispositif d'actionnement hydraulique afin d'actionner le dispositif. 60
 16. Appareil selon l'une quelconque des revendications 1 à 15, dans lequel le dispositif de commande comprend en outre un dispositif de stimulation électrique des muscles de la vessie pour contracter les muscles. 65
 17. Appareil selon la revendication 16, dans lequel le dispositif de stimulation électrique comprend une pluralité d'électrodes fixées aux muscles de la vessie. 70
 18. Appareil selon l'une quelconque des revendications 1 à 17, comprenant une paire implantable de dispositifs de restriction, le dispositif de commande commandant les dispositifs de restriction conçus pour fermer les uretères lors de la décharge de urine de la vessie. 75
 19. Appareil selon l'une quelconque des revendications 1 à 18, comprenant un sphincter urinaire artificiel, dans lequel un dispositif de restriction contrôlé par le dispositif de commande agit comme sphincter urinaire. 80
 20. Appareil selon l'une quelconque des revendications 1 à 19, comprenant un capteur pour mesurer tout

- paramètre lié à la pression ou au volume de l'urine dans la vessie, ledit capteur étant capable d'envoyer un signal au dispositif de commande, lequel est de ce fait conçu pour envoyer une information d'alarme hors du corps comme demande d'activation de l'élément motorisé.
- 5
21. Appareil selon l'une quelconque des revendications 1 à 20, comprenant en outre au moins l'un des éléments suivants : a) au moins un interrupteur implantable dans le patient pour contrôler manuellement et de manière non invasive le dispositif, b) un dispositif hydraulique comportant un réservoir hydraulique implantable, relié hydrauliquement au dispositif, dans lequel le dispositif est conçu pour être régulé de manière non invasive en appuyant manuellement sur le réservoir hydraulique, et c) une télécommande sans fil pour contrôler de manière non invasive l'appareil.
- 10
22. Système comprenant un appareil selon l'une quelconque des revendications 1 à 21, comprenant une source d'énergie interne implantable pour alimenter des composants de l'appareil implantables et consommant de l'énergie.
- 15
23. Appareil selon l'une quelconque des revendications 1 à 21, ou système selon la revendication 22, comprenant en outre un dispositif de transmission d'énergie sans fil pour exciter de manière non invasive des composants consommateurs d'énergie implantables du dispositif par une énergie sans fil.
- 20
24. Appareil selon l'une quelconque des revendications 1 à 21, ou système selon la revendication 22 ou 23, comprenant en outre un dispositif de transformation d'énergie pour transformer l'énergie sans fil transmise par le dispositif de transmission d'énergie d'une première forme en une seconde forme d'énergie, dans lequel le dispositif de transformation d'énergie est conçu pour effectuer au moins l'une des opérations suivantes : a) alimenter directement les composants implantables consommateurs d'énergie du dispositif par la seconde forme d'énergie ou b) lorsque le système comprend en outre une source d'énergie interne implantable pour alimenter des composants consommateurs d'énergie implantables du dispositif, pouvant être chargée par l'énergie sans fil, alimenter la source d'énergie interne avec la seconde forme d'énergie, le dispositif de transformation d'énergie transformant la première forme d'énergie transmise par le dispositif de transmission d'énergie en seconde forme d'énergie.
- 25
25. Dispositif d'appareil selon l'une quelconque des revendications 1 à 21, ou système selon la revendication 22, comprenant en outre un dispositif de contre-réaction pour envoyer des informations de retour de-
- 30
- puis l'intérieur du corps du patient vers l'extérieur de celui-ci, les informations de contre-réaction étant liées à au moins un paramètre physique du patient et à un paramètre fonctionnel lié au dispositif, dans lequel au moins un paramètre fonctionnel est corrélé au transfert de l'énergie sans fil.
- 35
26. Appareil selon l'une quelconque des revendications 1 à 21, ou système selon la revendication 22, comprenant en outre un capteur et/ou un dispositif de mesure et une unité de commande interne implantable pour contrôler le dispositif en réponse à des informations liées à au moins l'un des éléments suivants : a) un paramètre physique du patient détecté par le capteur ou mesuré par l'appareil de mesure et b) un paramètre fonctionnel lié au dispositif et détecté par le capteur ou mesuré par l'appareil de mesure.
- 40
27. Appareil selon l'une quelconque des revendications 1 à 21, ou système selon la revendication 22, comprenant en outre un dispositif de commande pour contrôler la transmission d'énergie sans fil à partir du dispositif de transmission d'énergie, et un récepteur d'énergie interne implantable pour recevoir l'énergie sans fil transmise, le récepteur d'énergie interne étant connecté à des composants implantables consommant de l'énergie du dispositif pour fournir directement ou indirectement l'énergie reçue à celui-ci, le système comprenant en outre un dispositif de détermination conçu pour déterminer un équilibre énergétique entre l'énergie reçue par le récepteur d'énergie interne et l'énergie utilisée pour les composants consommateurs d'énergie implantables du dispositif, dans lequel le dispositif de commande contrôle la transmission d'énergie sans fil à partir du dispositif de transmission d'énergie externe, sur la base du bilan énergétique déterminé par le dispositif de détermination, dans lequel le dispositif de détermination est conçu pour détecter au moins l'un des éléments suivants : a) une modification du bilan énergétique et le dispositif de commande contrôle la transmission de l'énergie sans fil en fonction du changement de bilan énergétique détecté, et b) une différence entre l'énergie reçue par le récepteur d'énergie interne et l'énergie utilisée pour les composants consommateurs d'énergie implantables du dispositif, et le dispositif de commande contrôle la transmission d'énergie sans fil en fonction de la différence d'énergie détectée.
- 45
28. Appareil selon l'une quelconque des revendications 1 à 21, ou système selon la revendication 22, comprenant en outre des composants électriques implantables comportant au moins une protection de niveau de tension et/ou au moins une protection de courant constant.
- 50
- 55

29. Dispositif d'appareil selon l'une quelconque des revendications 1 à 21, ou système selon la revendication 22, comprenant en outre un communicateur de données externe et un communicateur de données interne implantable communiquant avec le communicateur de données externe, dans lequel le communicateur interne transmet des données liées au dispositif ou au patient au communicateur de données externe et/ou le communicateur de données externe transmet des données au communicateur de données interne.

5

10

15

20

25

30

35

40

45

50

55

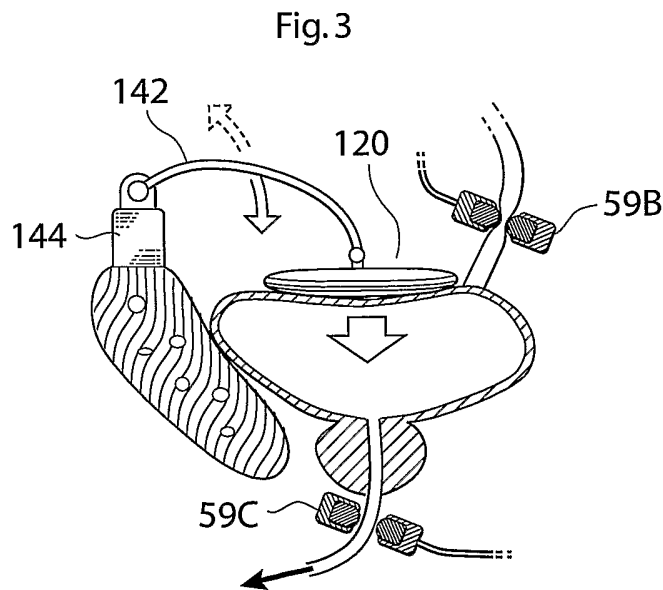
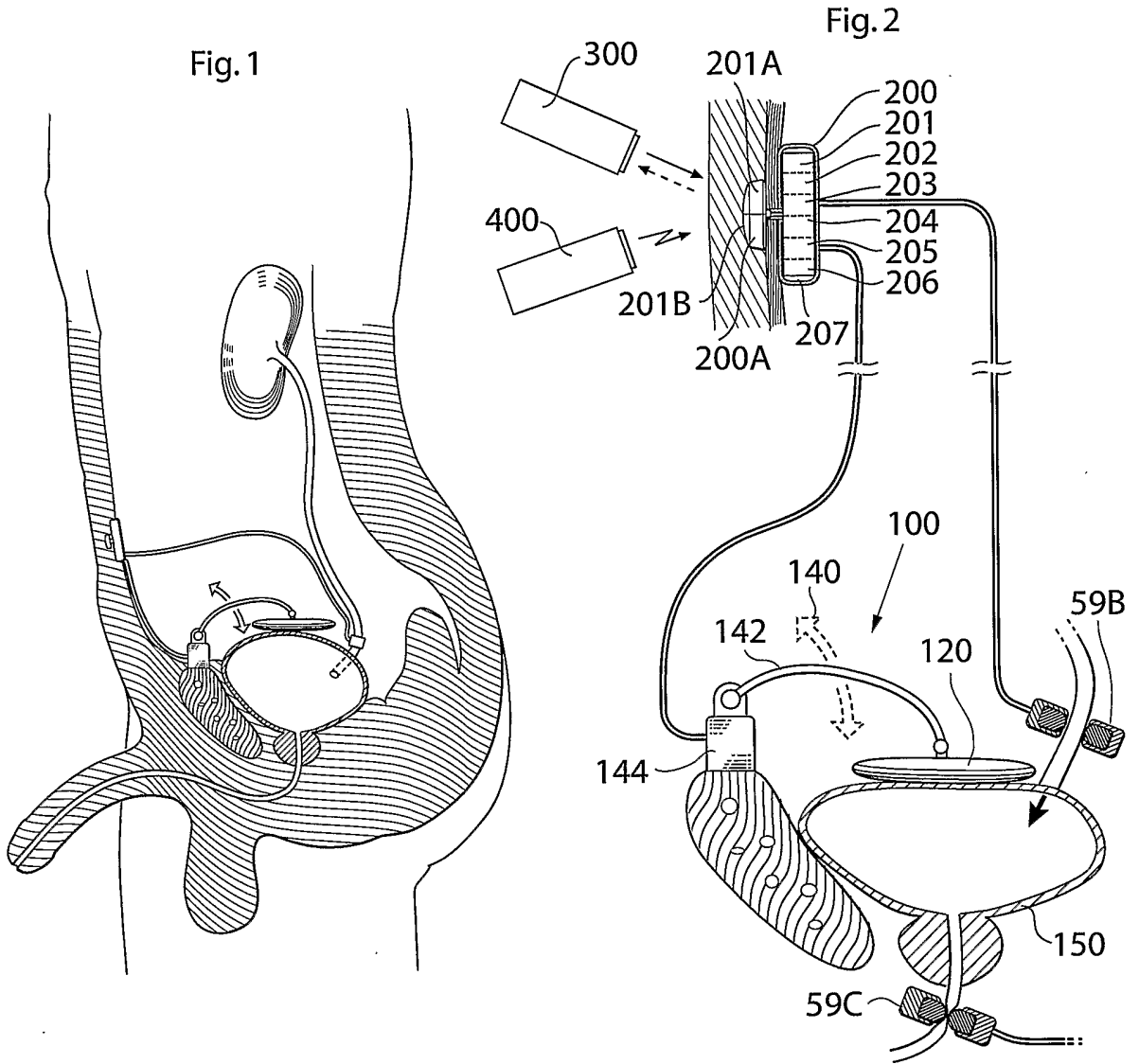

Fig. 4

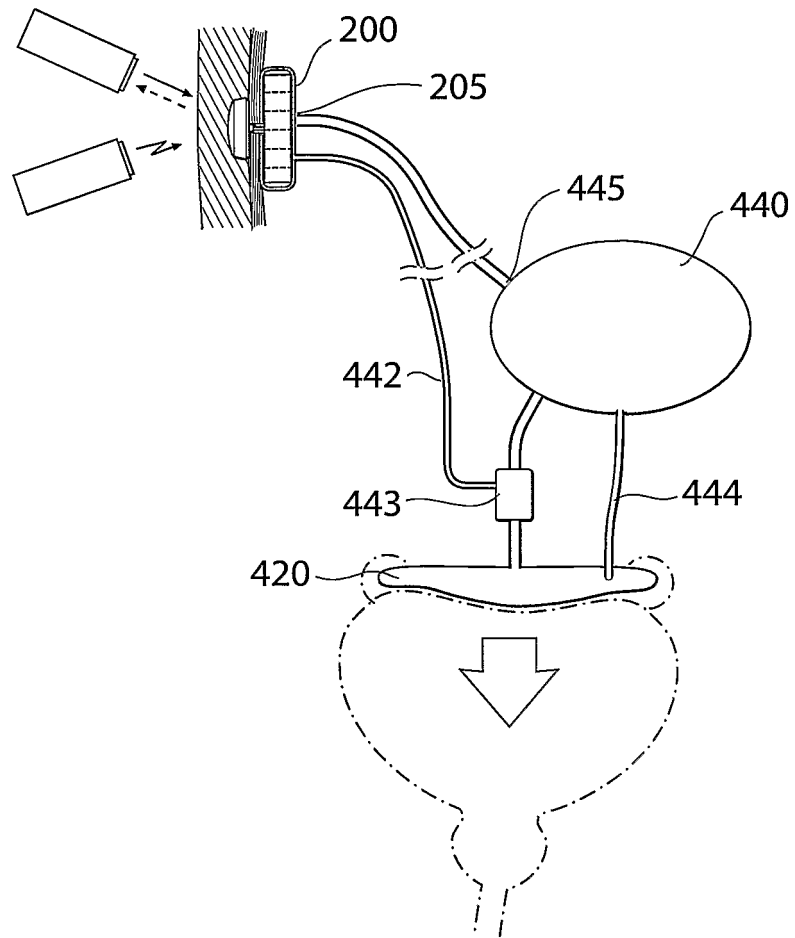

Fig. 5

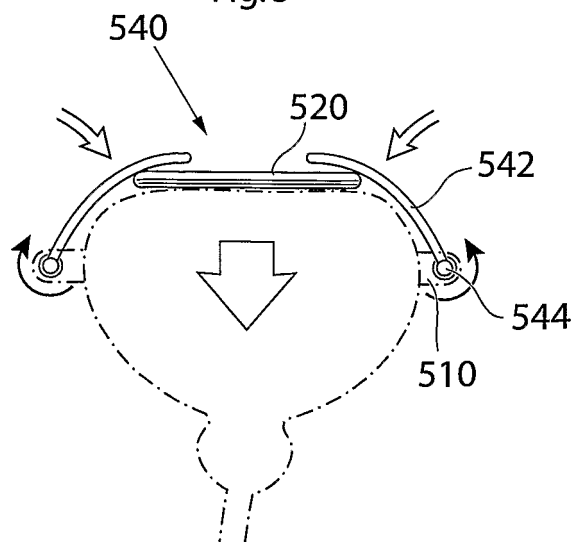

Fig. 5 A

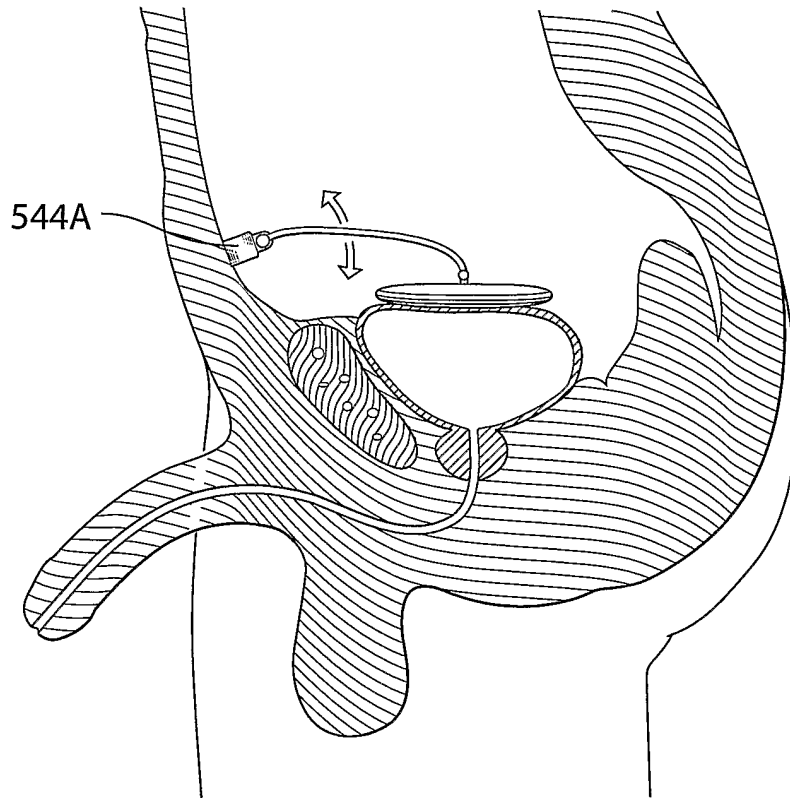

Fig. 5 B

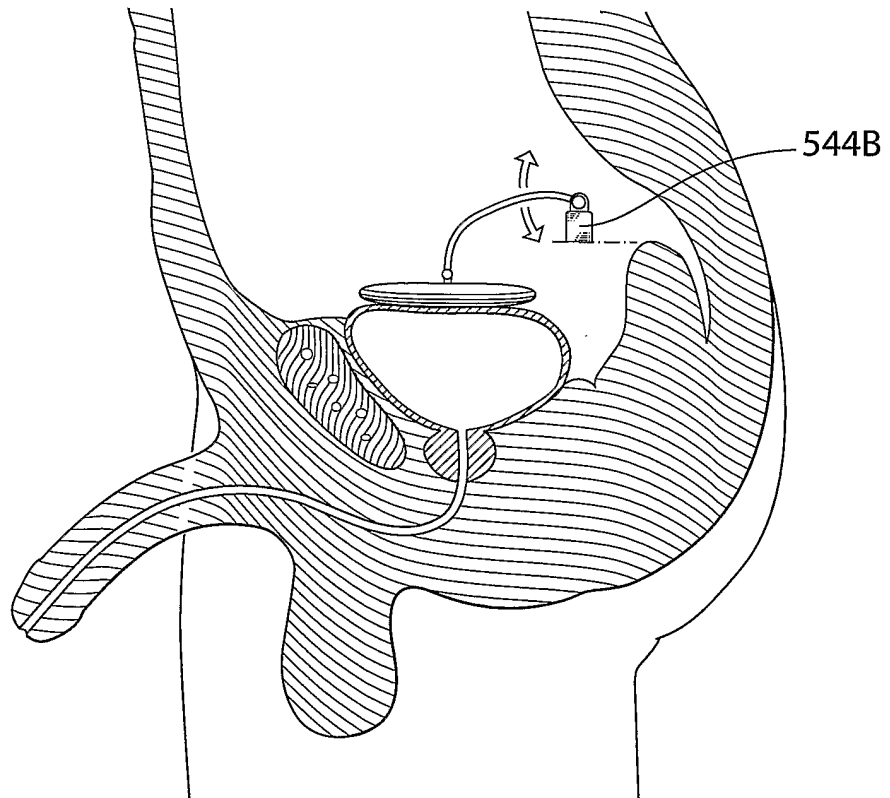

Fig. 5 C

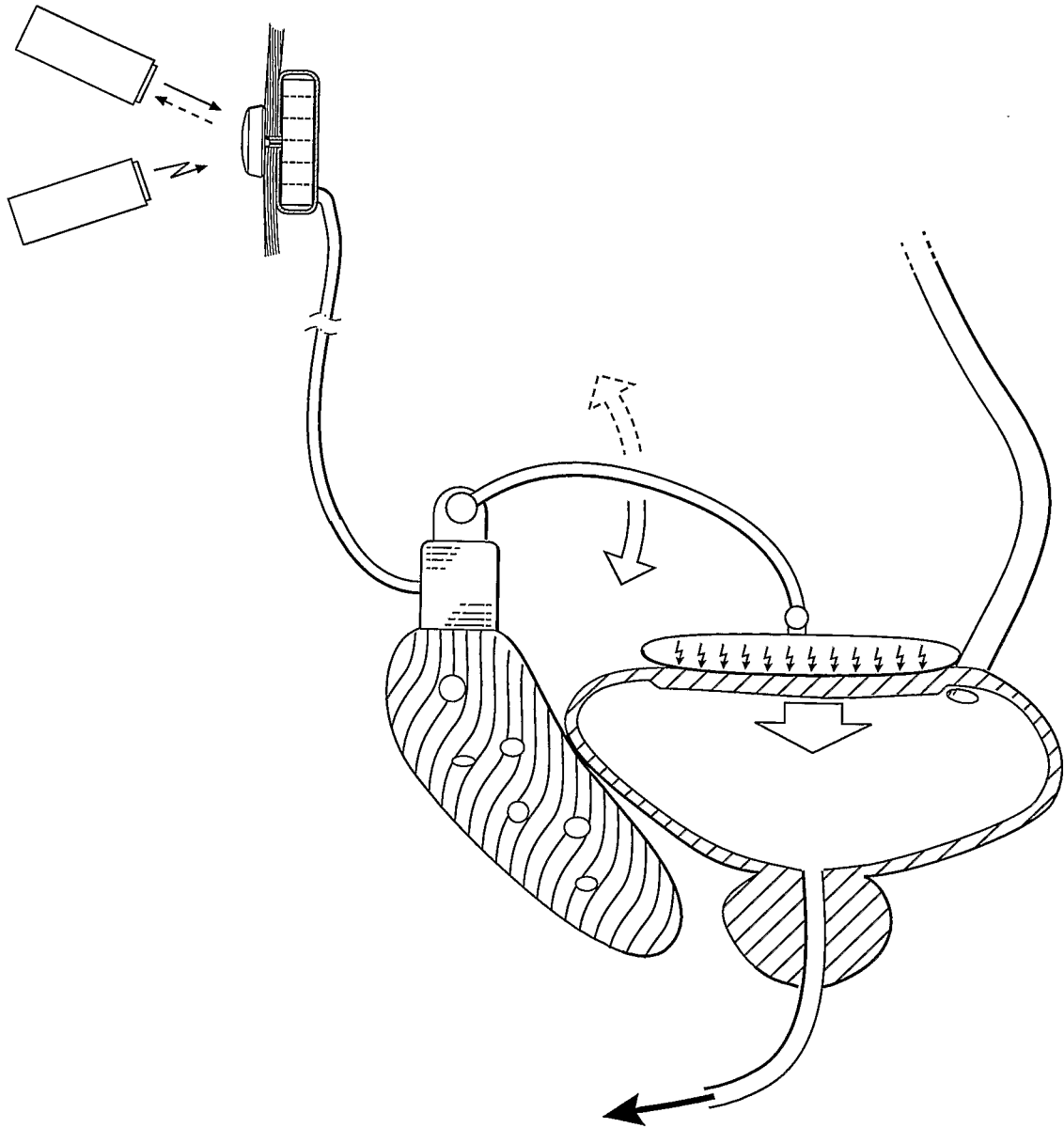
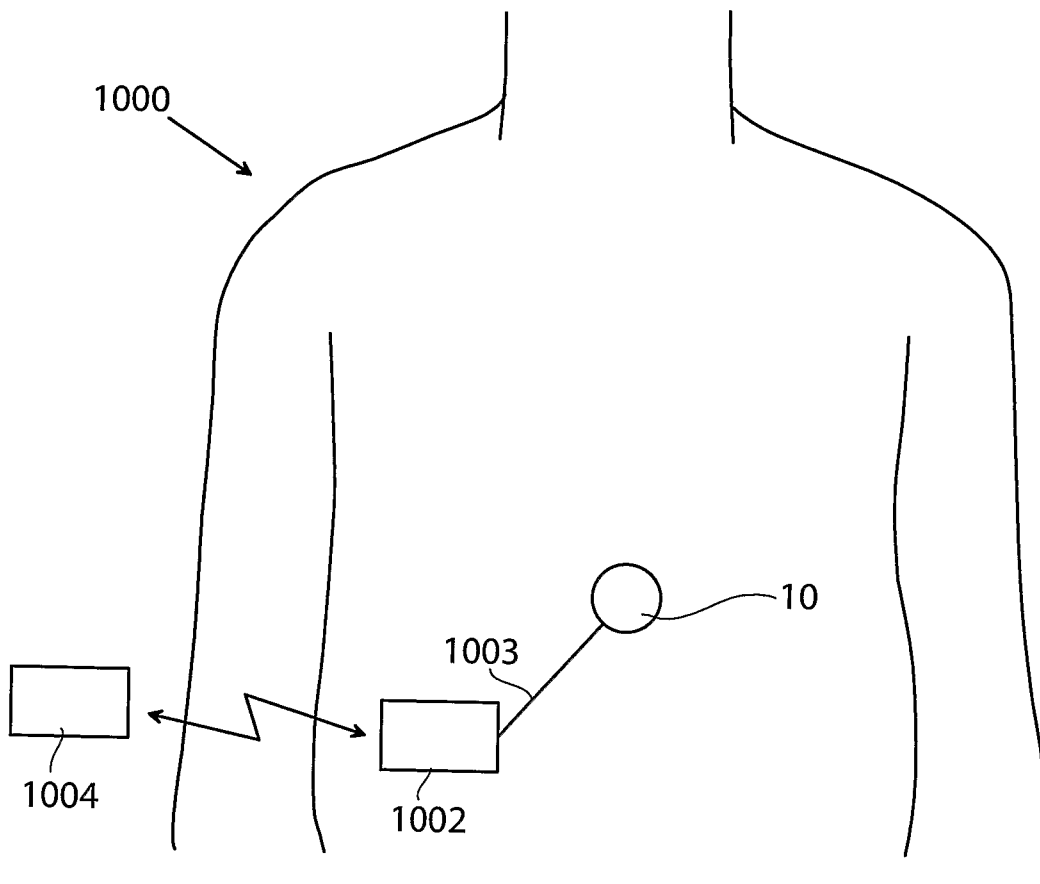

Fig.6



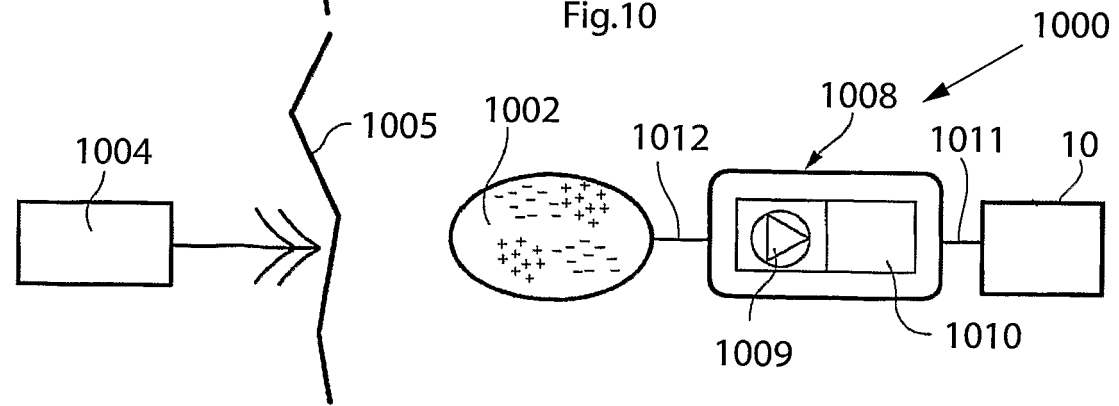
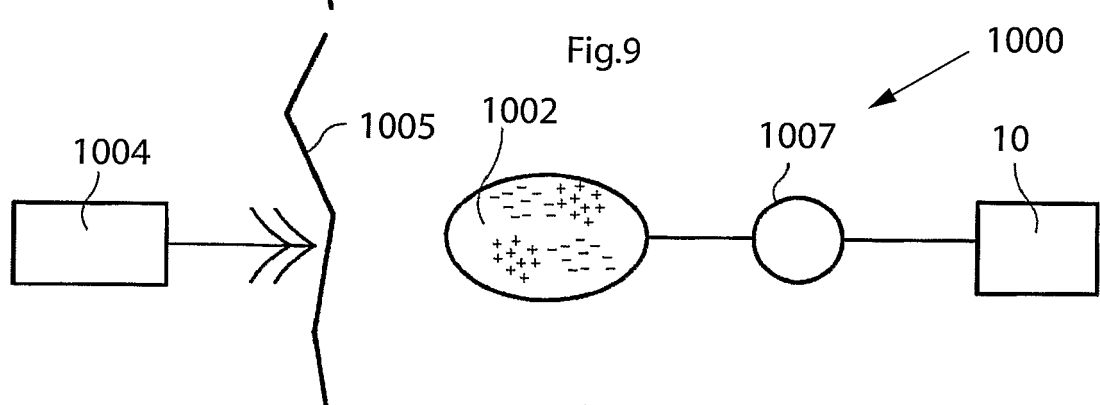
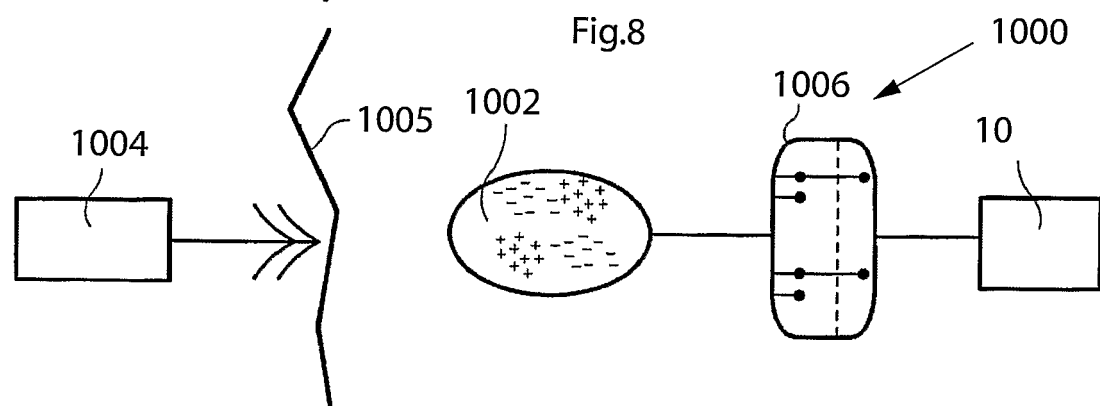
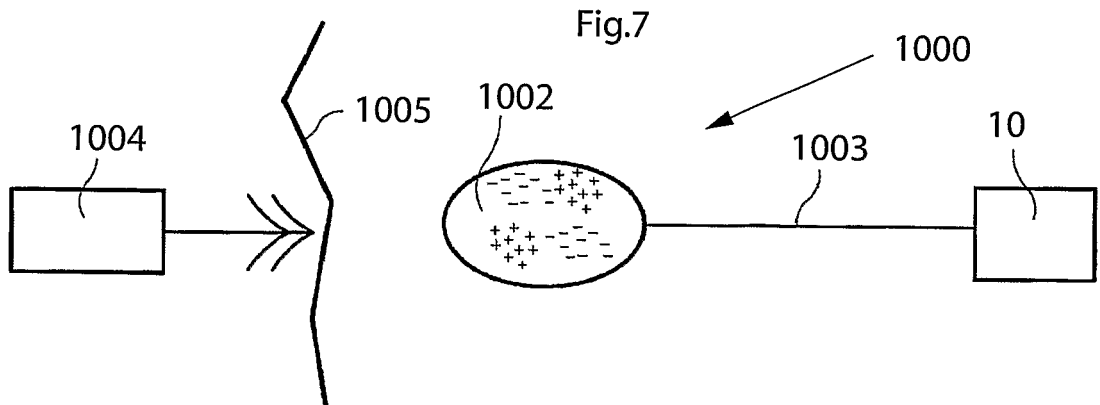

Fig.11

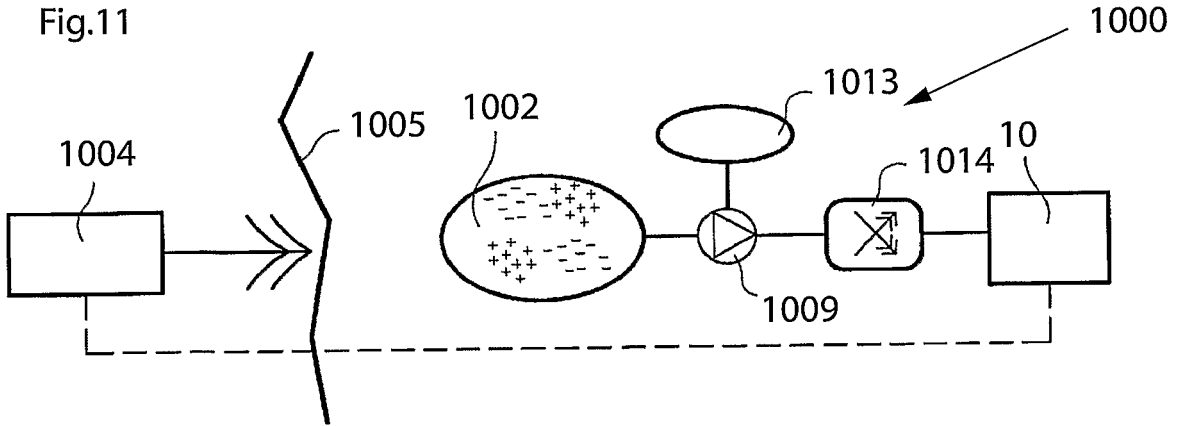

Fig.12

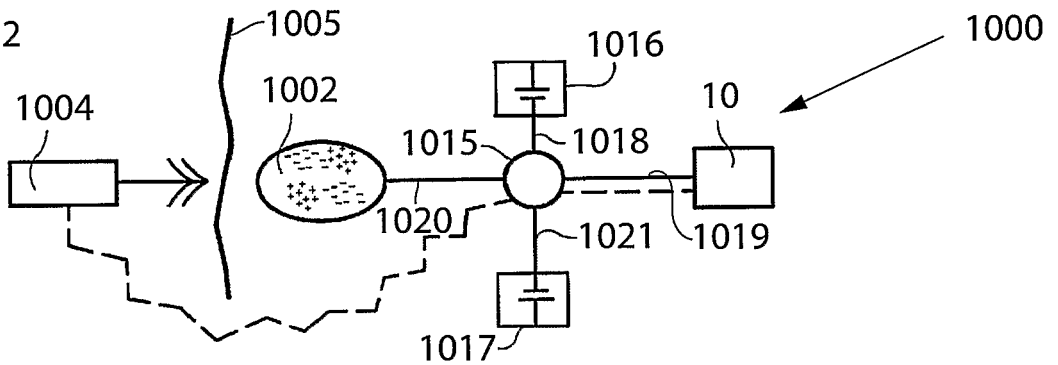

Fig.13

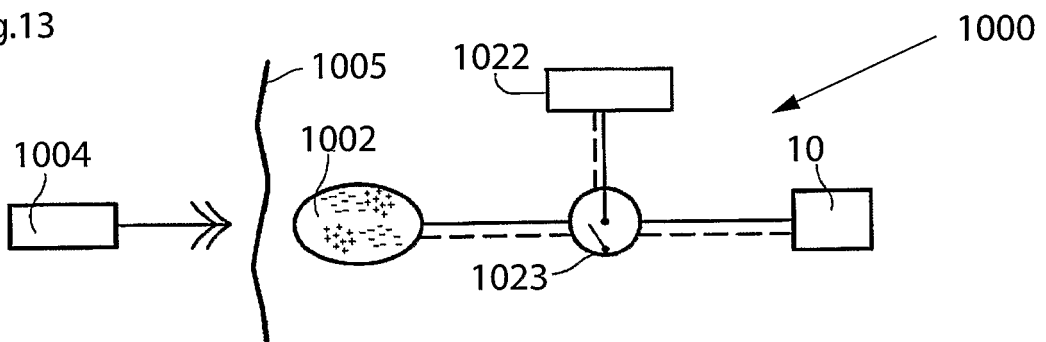

Fig.14

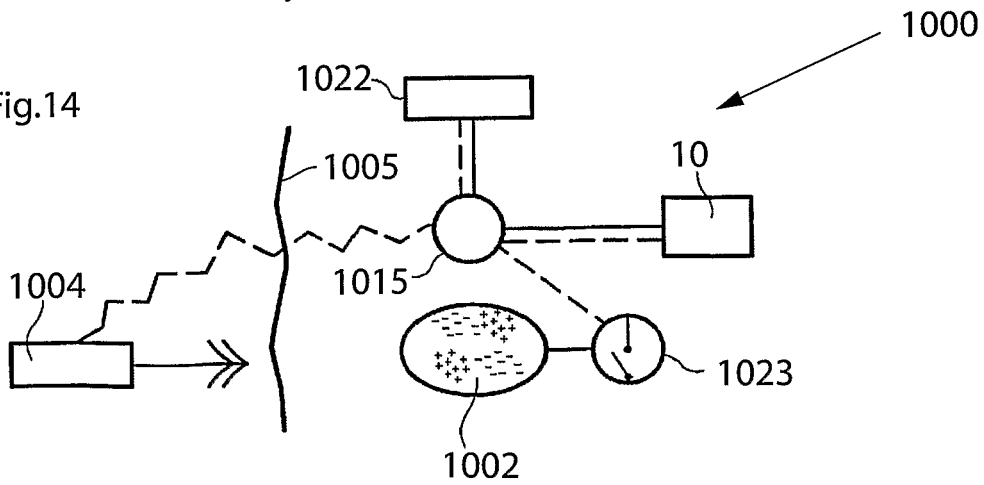

Fig.15

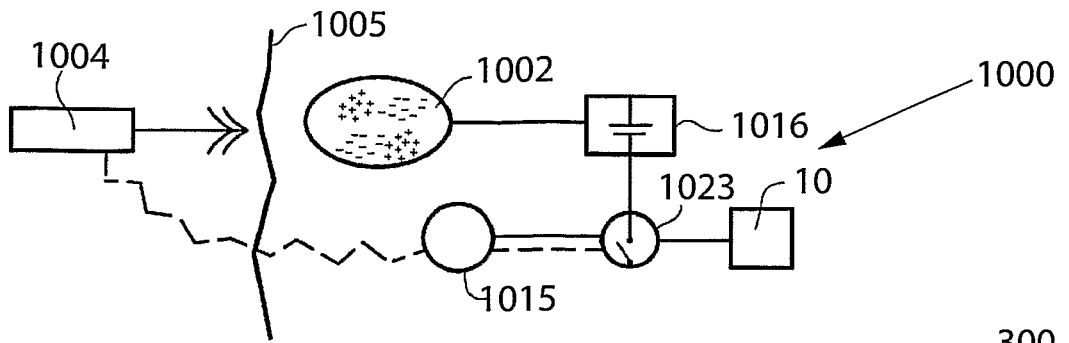

Fig.16

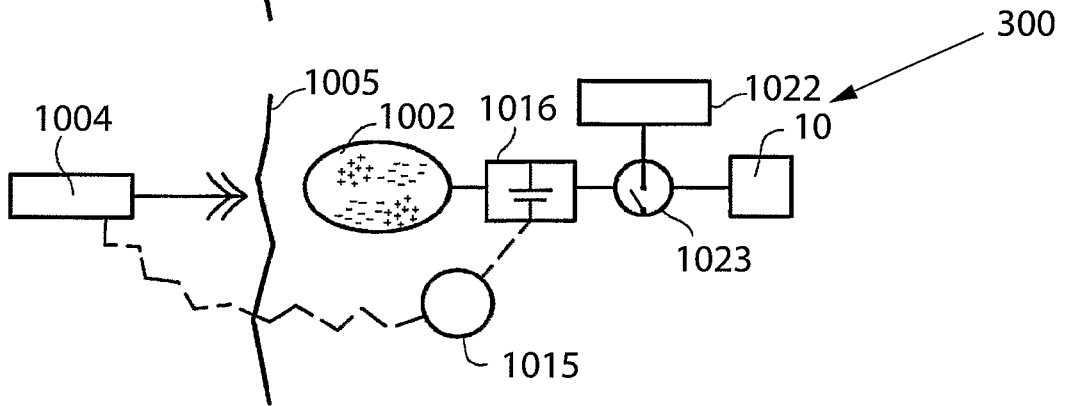

Fig.17

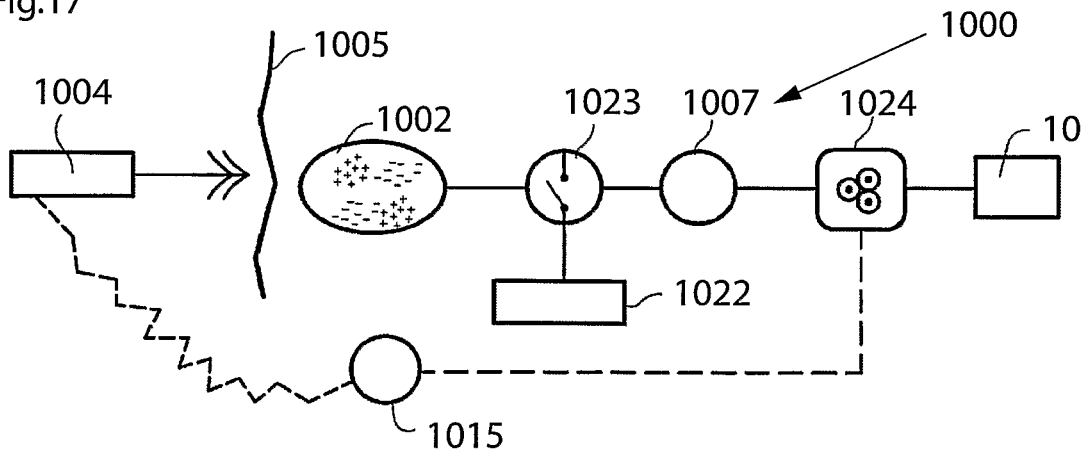

Fig.18

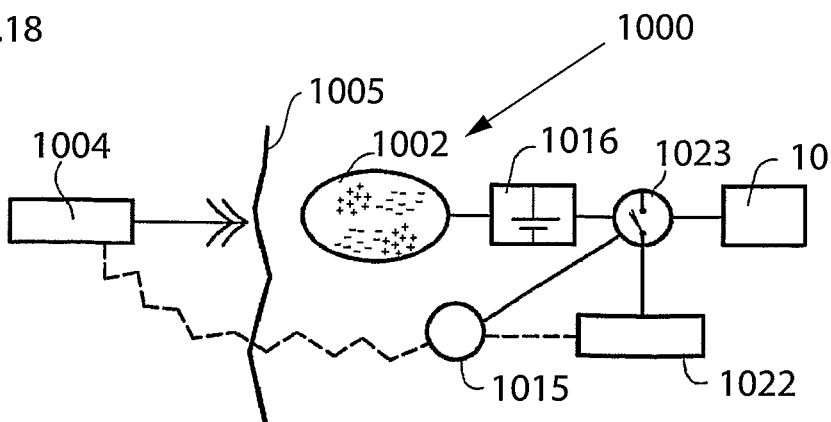

Fig.19

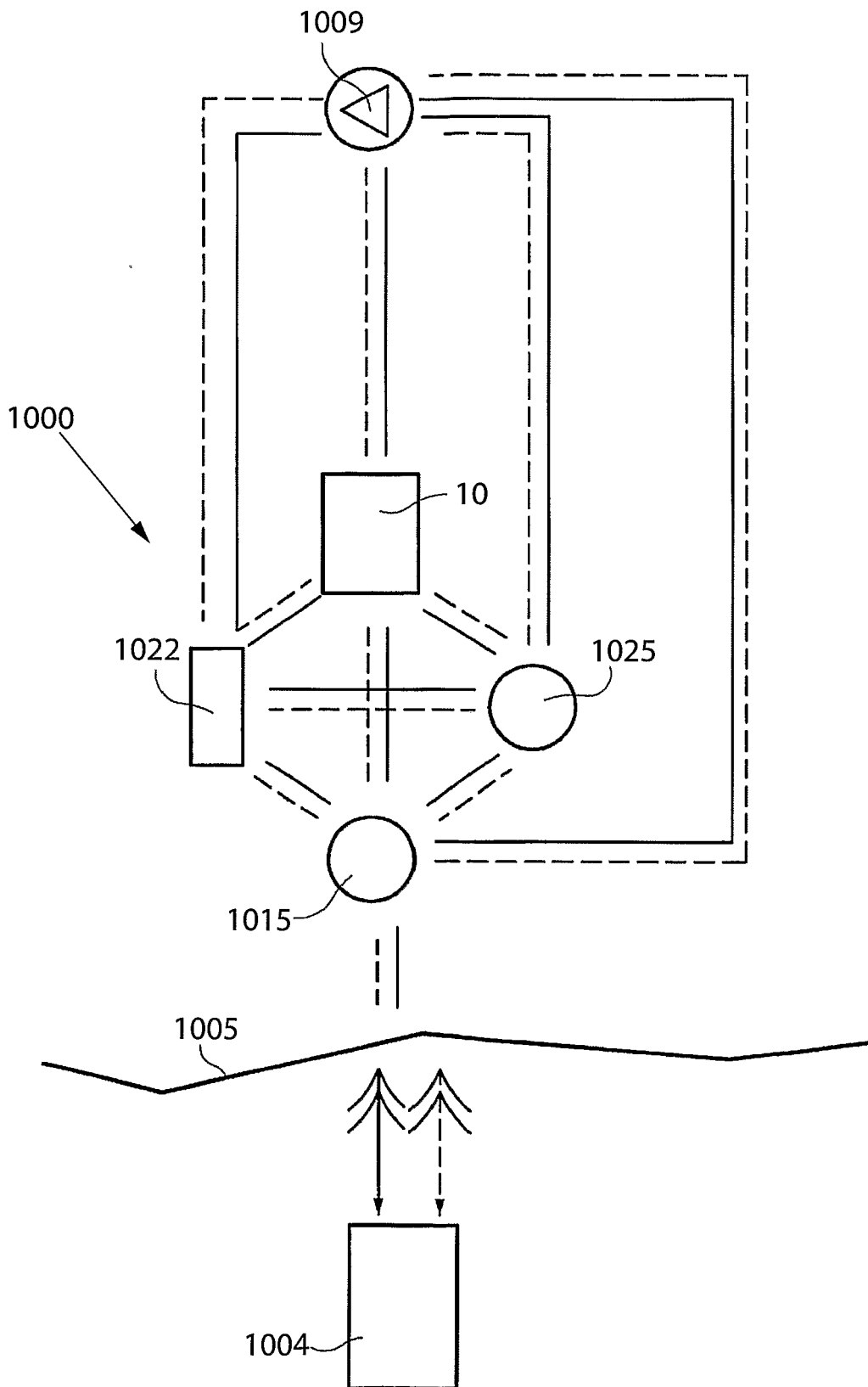

Fig.20

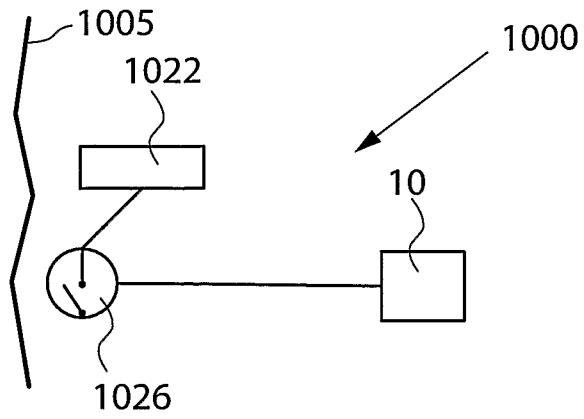

Fig.21

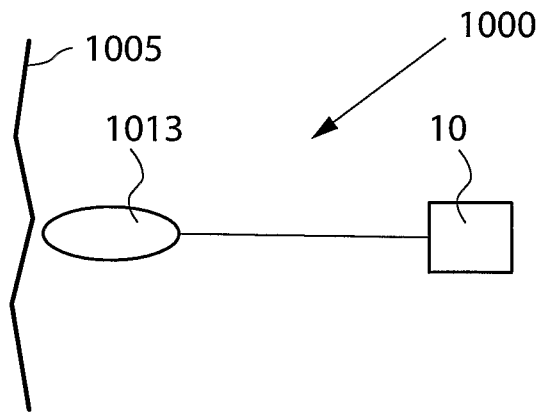

Fig.22

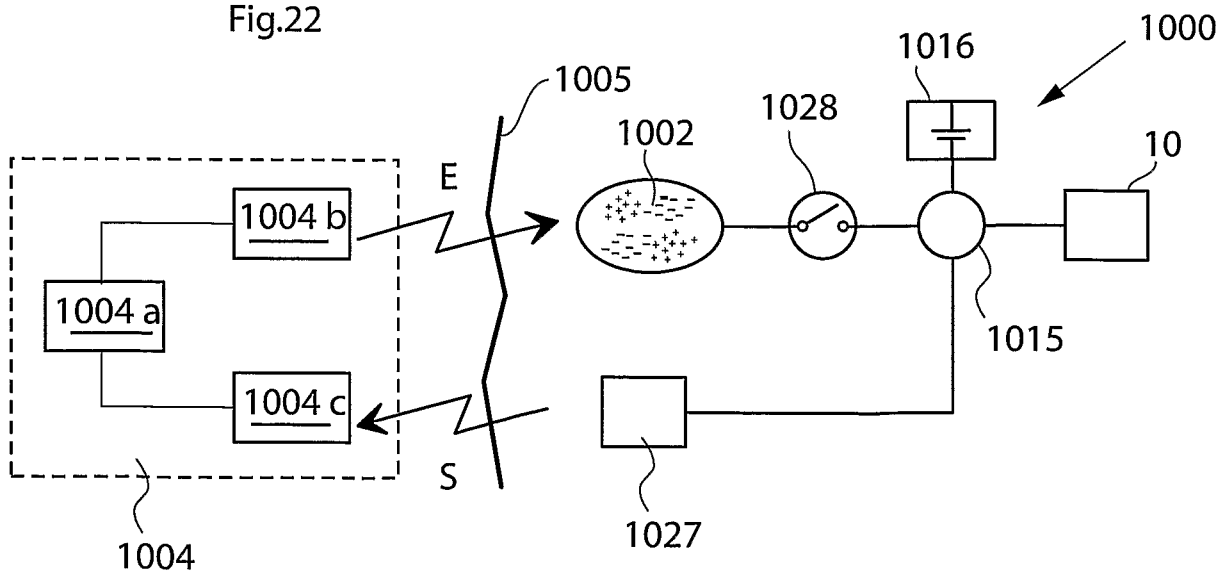

Fig.23

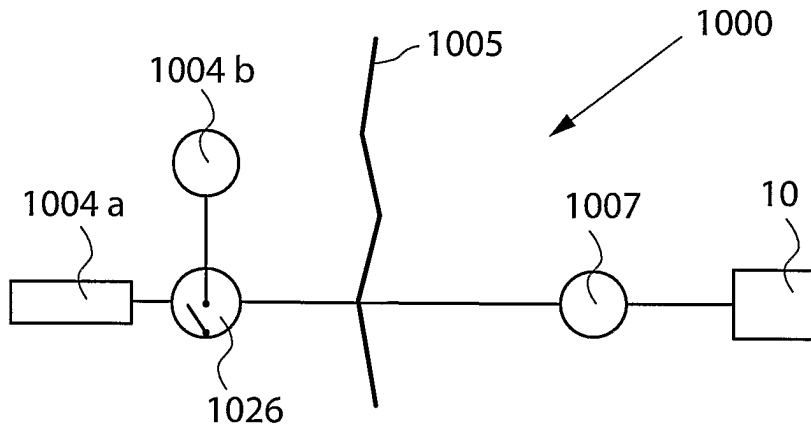

Fig.24

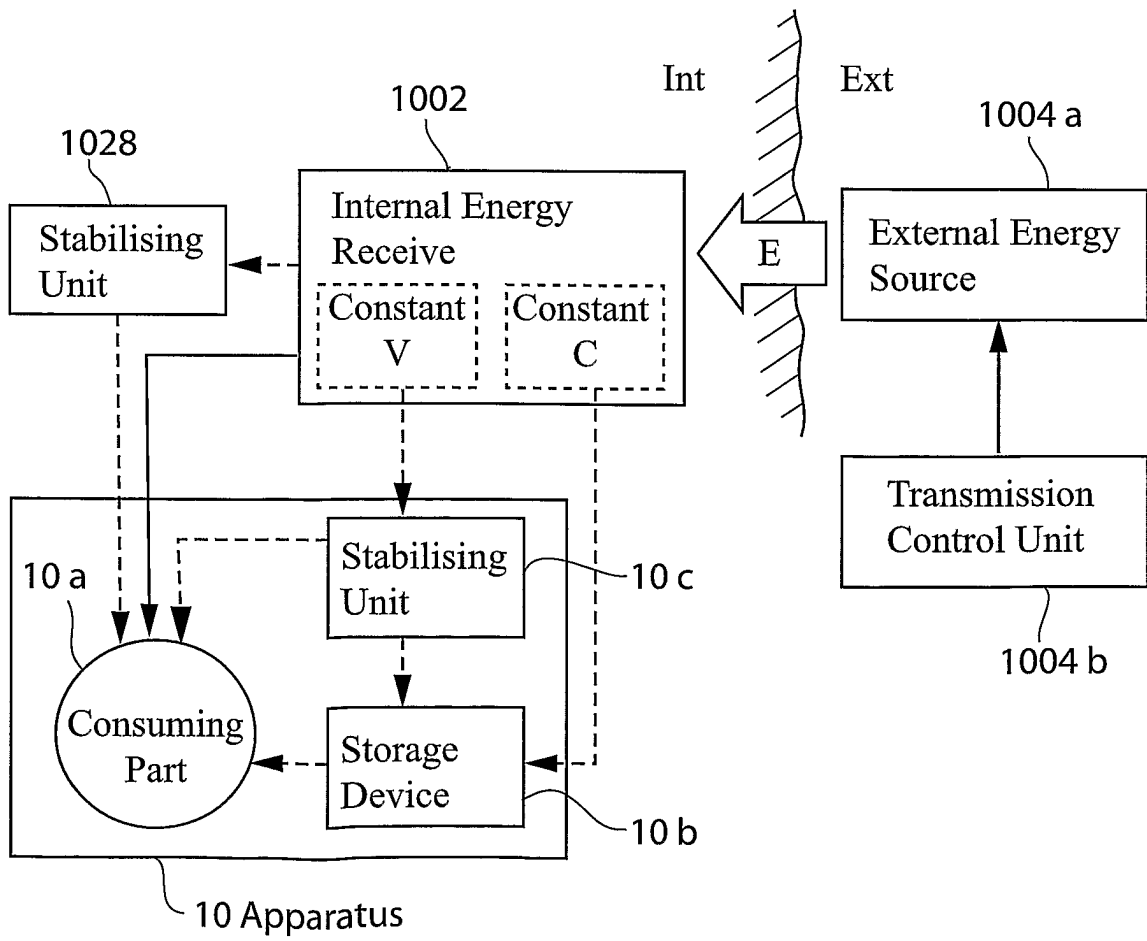

Fig.25

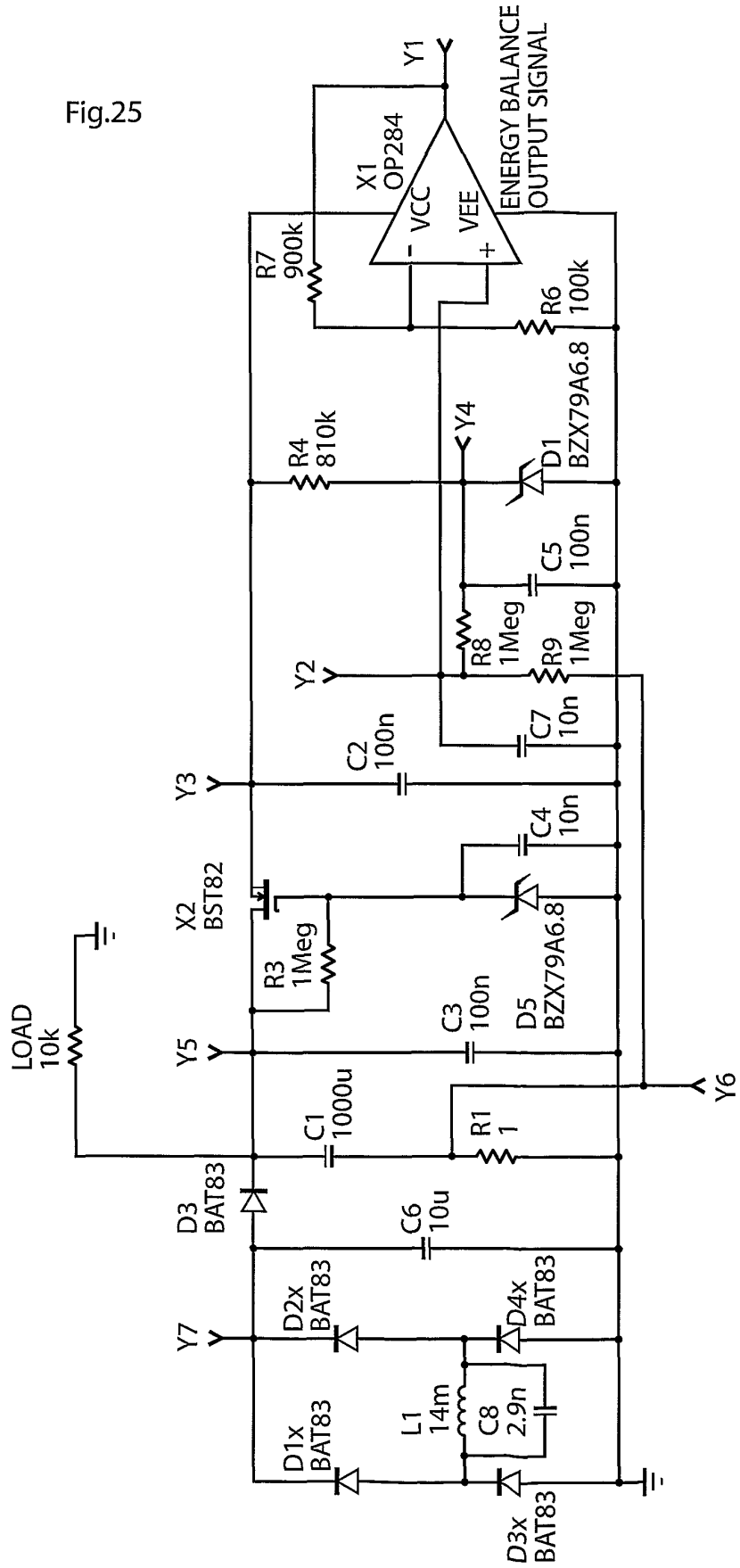

Fig.26

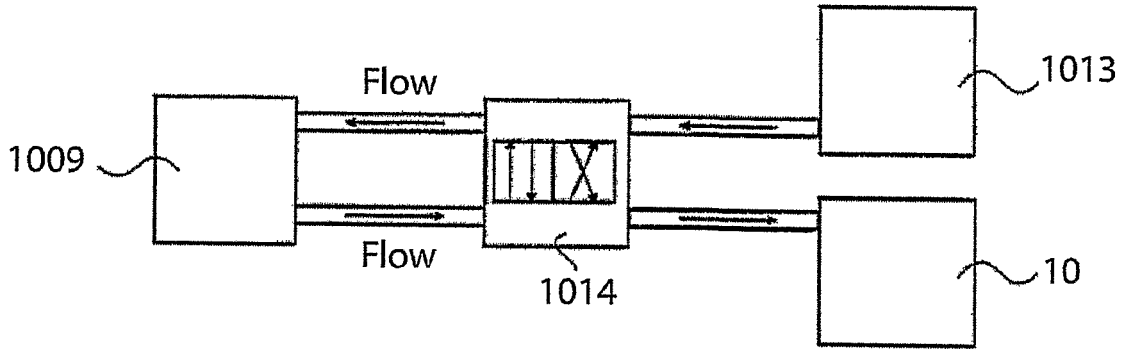

Fig.27

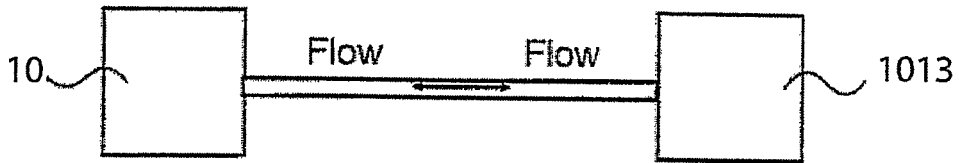

Fig.28

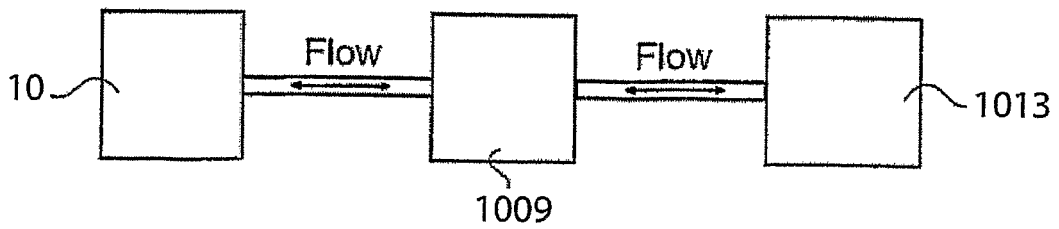

Fig. 29

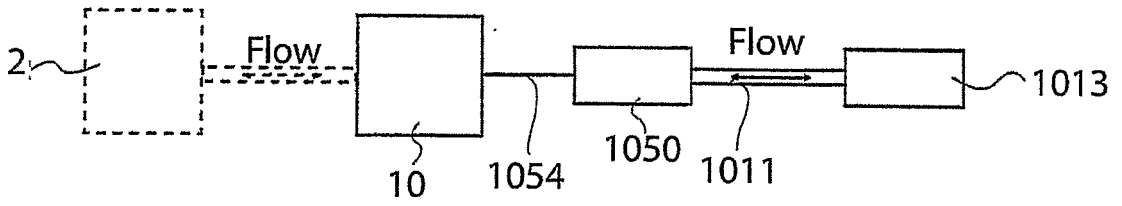

Fig. 30a

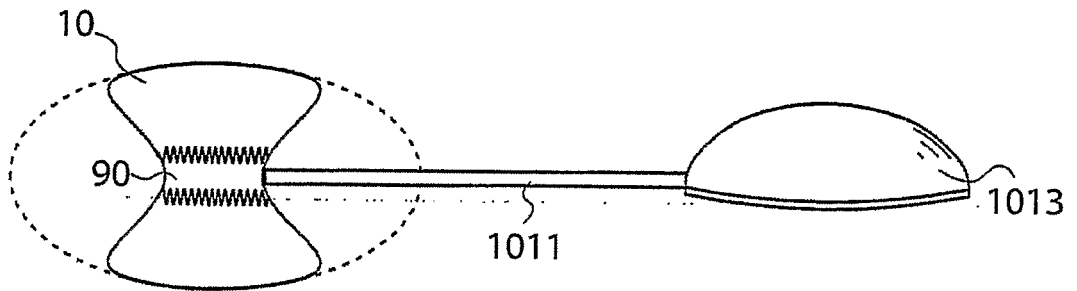

Fig. 30b

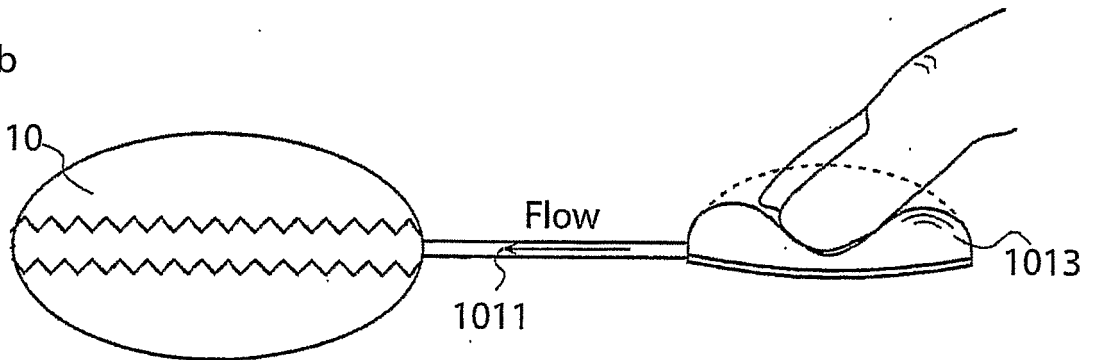

Fig. 30c

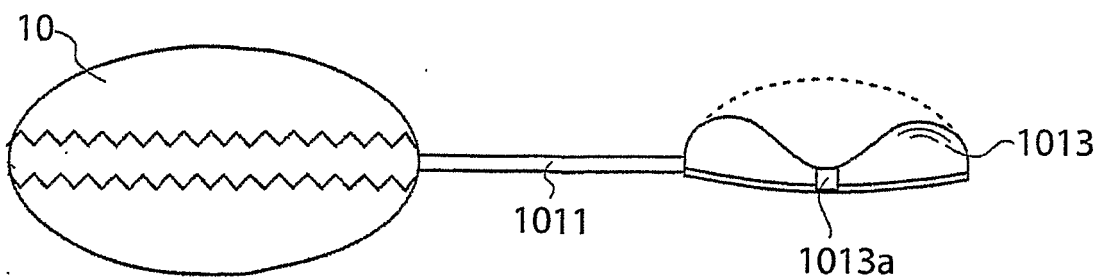

Fig.31

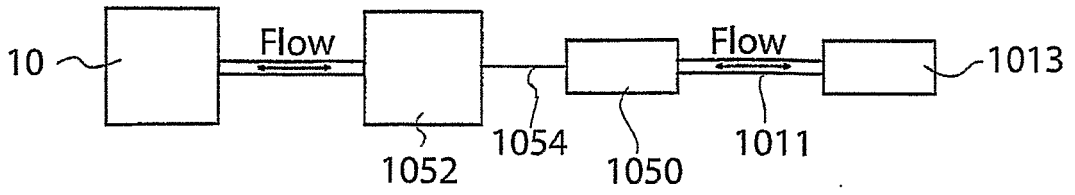

Fig.32a

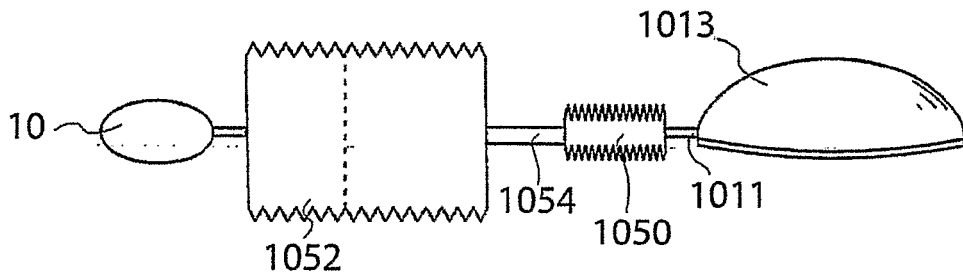

Fig.32b

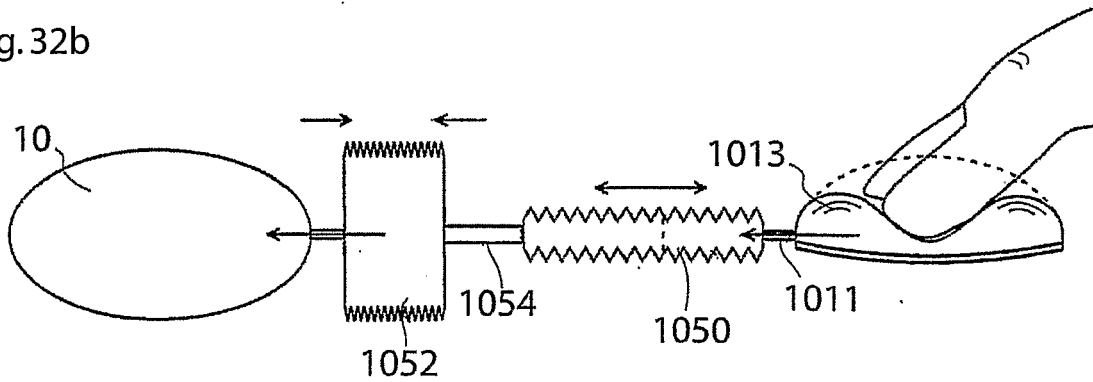
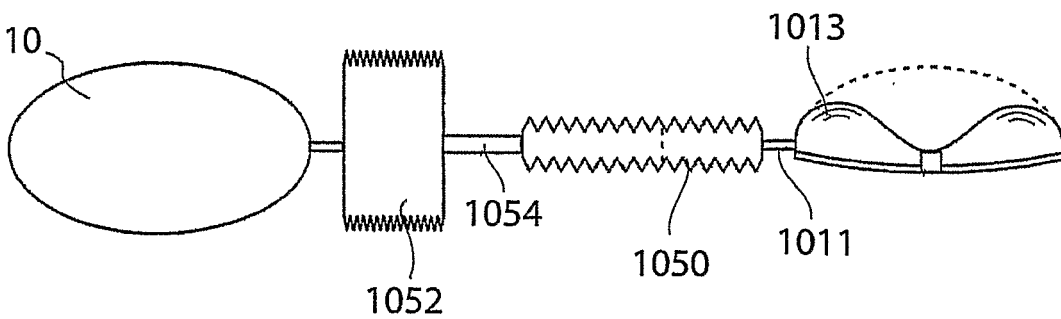

Fig.32c



REFERENCES CITED IN THE DESCRIPTION

This list of references cited by the applicant is for the reader's convenience only. It does not form part of the European patent document. Even though great care has been taken in compiling the references, errors or omissions cannot be excluded and the EPO disclaims all liability in this regard.

Patent documents cited in the description

- US 6393323 B [0002]
- US 2004242956 A [0002]

专利名称(译)	用于外部尿控的植入式装置		
公开(公告)号	EP2211767B1	公开(公告)日	2018-12-12
申请号	EP2008838487	申请日	2008-10-10
[标]申请(专利权)人(译)	米卢克斯控股股份有限公司		
申请(专利权)人(译)	MILUX HOLDING SA		
当前申请(专利权)人(译)	KIRK推广有限公司.		
[标]发明人	FORSELL PETER		
发明人	FORSELL, PETER		
IPC分类号	A61F2/00 A61B5/02 A61B17/12 A61B5/00 A61B5/07 A61B17/135 A61B17/00 A61F2/04		
CPC分类号	A61B5/076 A61B5/02007 A61B5/4393 A61B5/6862 A61B5/6876 A61B5/6885 A61B17/12009 A61B17/1355 A61B2017/00221 A61B2017/00411 A61B2017/00703 A61B2017/00734 A61B2090/065 A61B2562/0247 A61B2562/0261 A61F2/0036 A61F2/004 A61F2/042 A61F2002/30668 A61F2002/3067 A61F2250/0001 A61F2250/0002		
优先权	60/960716 2007-10-11 US 60/960715 2007-10-11 US		
其他公开文献	EP2211767A1 EP2211767A4		
外部链接	Espacenet		

摘要(译)

本发明涉及一种用于获得尿液控制和排空膀胱的可植入装置。该装置利用从膀胱外侧操作的动力构件 (100) 操作，该动力构件由支撑结构辅助以从膀胱排出尿液。控制装置 (200) 控制动力构件的操作。控制装置还包括能量源，用于操作动力构件和设备的其他能量消耗部件以及控制组件。

