

(19)



(11)

EP 2 211 714 B1

(12)

EUROPEAN PATENT SPECIFICATION

(45) Date of publication and mention of the grant of the patent:
23.11.2016 Bulletin 2016/47

(51) Int Cl.:
A61B 5/053^(2006.01) A61B 5/00^(2006.01)

(21) Application number: **08800155.7**

(86) International application number:
PCT/AU2008/001521

(22) Date of filing: **15.10.2008**

(87) International publication number:
WO 2009/059351 (14.05.2009 Gazette 2009/20)

(54) IMPEDANCE DETERMINATION

NACHWEIS DER IMPEDANZ

DÉTERMINATION DE L'IMPÉDANCE

(84) Designated Contracting States:
AT BE BG CH CY CZ DE DK EE ES FI FR GB GR HR HU IE IS IT LI LT LU LV MC MT NL NO PL PT RO SE SI SK TR

(74) Representative: **Appleyard Lees IP LLP**
15 Clare Road
Halifax HX1 2HY (GB)

(30) Priority: **05.11.2007 AU 2007906049**

(56) References cited:
WO-A1-2007/041783 JP-A- H 105 188
US-A1- 2004 158 167 US-A1- 2005 151 545
US-A1- 2007 010 758 US-B1- 6 236 886
US-B1- 6 339 722 US-B1- 6 631 292

(43) Date of publication of application:
04.08.2010 Bulletin 2010/31

(73) Proprietor: **Impedimed Limited**
Pinkenba, QLD 4008 (AU)

• **EZENWA B N ET AL: "MULTIPLE FREQUENCY SYSTEM FOR BODY COMPOSITION MEASUREMENT", MEDICAL INFORMATICS, ETHICS, CARDIOLOGY, INSTRUMENTATION. SAN DIEGO, OCT. 28 - 31, 1993; [PROCEEDINGS OF THE ANNUAL INTERNATIONAL CONFERENCE OF THE ENGINEERING IN MEDICINE AND BIOLOGY SOCIETY], NEW YORK, IEEE, US, vol. 15 PART 02, 28 October 1993 (1993-10-28), XP000436991,**

(72) Inventors:
• **CHETHAM, Scott**
Del Mar,
California 92014 (US)
• **DALY, Christopher Newton**
Newport,
New South Wales 2106 (AU)
• **BRUINSMA, Ian John**
Kings Langley,
New South Wales 2147 (AU)

EP 2 211 714 B1

Note: Within nine months of the publication of the mention of the grant of the European patent in the European Patent Bulletin, any person may give notice to the European Patent Office of opposition to that patent, in accordance with the Implementing Regulations. Notice of opposition shall not be deemed to have been filed until the opposition fee has been paid. (Art. 99(1) European Patent Convention).

Description**Background of the Invention**

5 [0001] The present invention relates to a method and apparatus for use in performing impedance measurements on a subject.

Description of the Prior Art

10 [0002] The reference in this specification to any prior publication (or information derived from it), or to any matter which is known, is not, and should not be taken as an acknowledgment or admission or any form of suggestion that the prior publication (or information derived from it) or known matter forms part of the common general knowledge in the field of endeavour to which this specification relates.

15 [0003] One existing technique for determining biological indicators relating to a subject, such as cardiac function, body composition, and other health status indicators, such as the presence of oedema, involves the use of bioelectrical impedance. This process typically involves using a measuring device to measure the electrical impedance of a subject's body using a series of electrodes placed on the skin surface. Changes in electrical impedance measured at the body's surface are used to determine parameters, such as changes in fluid levels, associated with the cardiac cycle, oedema, or the like.

20 [0004] Impedance measuring apparatus is sometimes sensitive to external factors, including stray capacitances between the subject and the local environment and the measurement apparatus, variations in electrode/tissue interface impedances, also known as electrode impedances, as well as stray capacitances and inductive coupling between the leads used to connect the measuring device to the electrodes.

25 [0005] US 2005/151545 describes an apparatus for measuring electrical impedance comprising: two input electrodes contacted to a subject for measuring impedance; a difference amplifier to which two signals inputted to the two input electrodes are inputted; a device for extracting a common mode component of two signals inputted to the two input electrodes; the third electrode contacted to the subject for measuring impedance; the first multiplier to which the common mode component is inputted; the first filter coupled with the first multiplier; the second multiplier coupled with the first filter; wherein a feedback signal outputted from the second multiplier is inputted to the third electrode.

30 [0006] US 2007/010758 describes an electroimpedance tomograph with a plurality of electrodes (1) is provided, which can be placed on the body of a patient and are connected via a selector switch (60) with a control and evaluating unit (20). The control and evaluating unit (20) cooperates with the selector switch (60) such that two electrodes each are supplied with an alternating current from an AC power source (22) and the detected analog voltage signals of the other electrodes are processed in order to reconstruct therefrom the impedance distribution of the body in the plane of the electrodes, wherein a symmetrical AC power source is used to reduce common-mode signals. To further suppress interferences due to common-mode signals, provisions are made for the control and evaluating unit (20) to be set up, furthermore, for detuning the common-mode signal of the alternating current on the body against the ground by means of a common-mode signal measuring electrode (4) and, based on this, the symmetry of the symmetrical AC power source such that the common-mode signal on the body is minimized, and the corresponding detuning parameters are stored for each electrode pair.

35 [0007] US 6,236,886 describes a method of obtaining tomographic images of the human body and the electrical impedance tomograph, in which a source of electric current is used to send electric current at levels undetectable by a human being to pairs of electrodes, between which at least two electrodes are placed. An algorithm of image reconstruction makes it possible to obtain the distribution of absolute conductivity of a body, characterizing the state of soft and bone tissues and blood vessels. The method is fast. It allows one to visualize the changes of conductivity during one cardiocycle and to observe blood filling the heart and vessels. It allows one to obtain time dependence of conductivity of internal areas of the heart, which is an impedance cardiogram, containing additional information about heart function. The use of visualization of conductivity of tissues allows one to observe the processes of internal hemorrhages, to reveal inflammations, to carry out studies of organs of digestion, to observe the state of various tumors, to carry out diagnosis of diseases of the mammary gland, to diagnose various lung diseases. The method allows one to monitor the variation of temperature of internal organs, raising the possibility of diagnosing diseases at early stages. The tomograph is a rather simple, compact device, convenient in operation, safe for a patient and attendants, operating with a standard personal computer. This device can be widely used in medical practice and clinical investigations.

40 [0008] US 6,631,292 describes an apparatus for measuring the resistance and reactance of a subject, or a segment of a subject, and includes a constant current source supplying a periodic high frequency input current to the subject. The constant current source controls the input current to a targeted value by measuring the actual current through the subject and comparing that actual current to the target current. The resulting error signal controls the input current. The input current is supplied to the segment through a coupling transformer, and another coupling transformer coupled to a

resistor in the subject path supplies the value of the actual current. The apparatus also includes an impedance measuring circuit that detects an output voltage across the segment, preferably using a detection coupling transformer, and produces at least one of a reactance output signal and a resistance output signal using the output voltage. In one aspect, an automatic shut down circuit is included.

5 [0009] US 6,339,722 describes an apparatus for the in vivo non-invasive measurement of a biological parameter concerning a bodily fluid of a person or animal in accordance with a calculation model, wherein the apparatus is provided with connections for at least two pairs of electrodes (2-5, 8-11) to be placed on the skin of a part of the body, a pair of input electrodes (2, 3, 8, 9) for feeding a measuring alternating current to the part of the body and a measuring pair of electrodes (4, 5, 10, 11) for measuring the voltage at the measuring pair of electrodes, comprising a current source (7, 10 12) providing the measuring alternating current, a transformer (31) for the transformation of the measuring voltage into a bio-impedance signal, being a measure of the bio-impedance of the part of the body, and means for the generation of signals which form a measure for further parameters to be determined with the aid of the calculating model, said signals encompassing a signal forming a measure for the time derivative of the bio-impedance signal. The current source (7, 12) has a minimal radiation configuration and is suitable for generating a measuring current having a constant 15 amplitude on at least two frequencies, a low frequency and a high frequency, in a frequency range of up to about 2000 kHz.

Summary of the Present Invention

[0010] The present invention seeks to substantially overcome, or at least ameliorate, one or more disadvantages of existing arrangements.

[0011] This is achieved, according to the invention by an apparatus as recited in claim 1, and a method according to claim 22.

[0012] Preferred embodiments are recited in the dependent claims.

[0013] It will be appreciated that the invention may be used for the diagnosis of the presence, absence or range of a range of conditions and illnesses, including, but not limited to oedema, pulmonary oedema, lymphodema, body composition, cardiac function, and the like.

Brief Description of the Drawings

[0014] An example of the present invention will now be described with reference to the accompanying drawings, in which: -

Figure 1 is a schematic diagram of an example of an impedance measuring device;
 Figure 2 is a flowchart of an example of a process for performing impedance measuring;
 35 Figure 3 is a schematic diagram of a second example of an impedance measuring device;
 Figure 4 is a schematic diagram of an example of a computer system;
 Figure 5 is a schematic of an example of the functionality of the processing system of Figure 3;
 Figures 6A to 6C are a flowchart of a second example of a process for performing impedance measurements;
 Figure 7A is a schematic diagram of an example of an electrode system incorporating a signal generator and a sensor;
 40 Figure 7B is a schematic diagram illustrating cross electrode capacitive coupling;
 Figure 7C is a schematic diagram of an example of a cross electrode capacitance cancelling circuit;
 Figure 7D is a schematic diagram of an example of an input capacitance cancelling circuit;
 Figure 8 is a schematic diagram of an example of lead connections between the measuring device and the electrode system of Figure 7A;
 45 Figures 9 is a schematic diagram of an example of a lead arrangement;
 Figures 10A and 10B are schematic diagrams of examples of electrode configurations used during balancing according to the invention;
 Figure 10C is a schematic diagram of effective electrical models for the electrode arrangements of Figures 10A and 10B; and,
 50 Figure 11 is a flow chart of a further example of an impedance measurement process.
 Figure 12A is a schematic diagram of an effective electrical model of the body;
 Figure 12B is a schematic diagram of the complex voltages for the electrical model of Figure 12A when the voltage is balanced based on the voltage magnitude only;
 Figure 12C is a schematic diagram of the complex voltages for the electrical model of Figure 12A when the voltage is balanced based on the voltage magnitude and phase;
 55 Figure 12D is a schematic diagram of an effective electrical model of the body;
 Figure 12E is a schematic diagram of the complex voltages for the electrical model of Figure 12D when the voltage is balanced based on the voltage magnitude only; and,

Figure 12F is a schematic diagram of the complex voltages for the electrical model of Figure 12D when the voltage is balanced based on the voltage magnitude and phase.

Detailed Description of the Preferred Embodiments

[0015] An example of apparatus suitable for performing an analysis of a subject's bioelectric impedance will now be described with reference to Figure 1.

[0016] As shown the apparatus includes a measuring device 100 including a processing system 102, connected to one or more signal generators 117A, 117B, via respective first leads 123A, 123B, and to one or more sensors 118A, 118B, via respective second leads 125A, 125B. The connection may be via a switching device, such as a multiplexer, although this is not essential.

[0017] In use, the signal generators 117A, 117B are coupled to two first electrodes 113A, 113B, which therefore act as drive electrodes to allow signals to be applied to the subject S, whilst the one or more sensors 118A, 118B are coupled to the second electrodes 115A, 115B, which act as sense electrodes, allowing signals across the subject S to be sensed.

[0018] The signal generators 117A, 117B and the sensors 118A, 118B may be provided at any position between the processing system 102 and the electrodes 113A, 113B, 115A, 115B, and may be integrated into the measuring device 100. However, in one example, the signal generators 117A, 117B and the sensors 118A, 118B are integrated into an electrode system, or another unit provided near the subject S, with the leads 123A, 123B, 125A, 125B connecting the signal generators 117A, 117B and the sensors 118A, 118B to the processing system 102.

[0019] It will be appreciated that the above described system is a two channel device, used to perform a classical four-terminal impedance measurement, with each channel being designated by the suffixes A, B respectively. The use of a two channel device is for the purpose of example only, as will be described in more detail below.

[0020] An optional external interface 103 can be used to couple the measuring device 100, via wired, wireless or network connections, to one or more peripheral devices 104, such as an external database or computer system, barcode scanner, or the like. The processing system 102 will also typically include an I/O device 105, which may be of any suitable form such as a touch screen, a keypad and display, or the like.

[0021] In use, the processing system 102 is adapted to generate control signals, which cause the signal generators 117A, 117B to generate one or more alternating signals, such as voltage or current signals of an appropriate waveform, which can be applied to a subject S, via the first electrodes 113A, 113B. The sensors 118A, 118B then determine the voltage across or current through the subject S, using the second electrodes 115A, 115B and transfer appropriate signals to the processing system 102.

[0022] Accordingly, it will be appreciated that the processing system 102 may be any form of processing system which is suitable for generating appropriate control signals and at least partially interpreting the measured signals to thereby determine the subject's bioelectrical impedance, and optionally determine other information such as relative fluid levels, or the presence, absence or degree of conditions, such as oedema, lymphoedema, measures of body composition, cardiac function, or the like.

[0023] The processing system 102 may therefore be a suitably programmed computer system, such as a laptop, desktop, PDA, smart phone or the like. Alternatively the processing system 102 may be formed from specialised hardware, such as an FPGA (field programmable gate array), or a combination of a programmed computer system and specialised hardware, or the like, as will be described in more detail below.

[0024] In use, the first electrodes 113A, 113B are positioned on the subject to allow one or more signals to be injected into the subject S. The location of the first electrodes will depend on the segment of the subject S under study. Thus, for example, the first electrodes 113A, 113B can be placed on the thoracic and neck region of the subject S to allow the impedance of the chest cavity to be determined for use in cardiac function analysis. Alternatively, positioning electrodes on the wrist and ankles of a subject allows the impedance of limbs and/or the entire body to be determined, for use in oedema analysis, or the like.

[0025] Once the electrodes are positioned, one or more alternating signals are applied to the subject S, via the first leads 123A, 123B and the first electrodes 113A, 113B. The nature of the alternating signal will vary depending on the nature of the measuring device and the subsequent analysis being performed.

[0026] For example, the system can use Bioimpedance Analysis (BIA) in which a single low frequency signal (typically < 50 kHz) is injected into the subject S, with the measured impedance being used directly in the assessment of relative intracellular and extracellular fluid levels. In contrast Bioimpedance Spectroscopy (BIS) devices utilise frequencies ranging from very low frequencies (4 kHz) to higher frequencies (1000 kHz), and can use as many as 256 or more different frequencies within this range, to allow multiple impedance measurements to be made within this range.

[0027] Thus, the measuring device 100 may either apply an alternating signal at a single frequency, at a plurality of frequencies simultaneously, or a number of alternating signals at different frequencies sequentially, depending on the preferred implementation. The frequency or frequency range of the applied signals may also depend on the analysis being performed.

[0028] In one example, the applied signal is generated by a voltage generator, which applies an alternating voltage to the subject S, although alternatively current signals may be applied. In one example, the voltage source is typically symmetrically arranged, with each of the signal generators 117A, 117B being independently controllable, to allow the signal voltage across the subject to be varied.

[0029] A voltage difference and/or current is measured between the second electrodes 115A, 115B. In one example, the voltage is measured differentially, meaning that each sensor 118A, 118B is used to measure the voltage at each second electrode 115A, 115B and therefore need only measure half of the voltage as compared to a single ended system.

[0030] The acquired signal and the measured signal will be a superposition of voltages generated by the human body, such as the ECG (electrocardiogram), voltages generated by the applied signal, and other signals caused by environmental electromagnetic interference. Accordingly, filtering or other suitable analysis may be employed to remove unwanted components.

[0031] The acquired signal is typically demodulated to obtain the impedance of the system at the applied frequencies. One suitable method for demodulation of superposed frequencies is to use a Fast Fourier Transform (FFT) algorithm to transform the time domain data to the frequency domain. This is typically used when the applied current signal is a superposition of applied frequencies. Another technique not requiring windowing of the measured signal is a sliding window FFT.

[0032] In the event that the applied current signals are formed from a sweep of different frequencies, then it is more typical to use a signal processing technique such as multiplying the measured signal with a reference sine wave and cosine wave derived from the signal generator, or with measured sine and cosine waves, and integrating over a whole number of cycles. This process, known variously as quadrature demodulation or synchronous detection, rejects all uncorrelated or asynchronous signals and significantly reduces random noise.

[0033] Other suitable digital and analogue demodulation techniques will be known to persons skilled in the field.

[0034] In the case of BIS, impedance or admittance measurements are determined from the signals at each frequency by comparing the recorded voltage and the current through the subject. The demodulation algorithm can then produce amplitude and phase signals at each frequency.

[0035] As part of the above described process, the distance between the second electrodes 115A, 115B may be measured and recorded. Similarly, other parameters relating to the subject may be recorded, such as the height, weight, age, sex, health status, any interventions and the date and time on which they occurred. Other information, such as current medication, may also be recorded. This can then be used in performing further analysis of the impedance measurements, so as to allow determination of the presence, absence or degree of oedema, to assess body composition, or the like.

[0036] The accuracy of the measurement of impedance can be subject to a number of external factors. These can include, for example, the effect of capacitive coupling between the subject and the surrounding environment, the leads and the subject, the electrodes, or the like, which will vary based on factors such as lead construction, lead configuration, subject position, or the like. Additionally, there are typically variations in the impedance of the electrical connection between the electrode surface and the skin (known as the "electrode impedance"), which can depend on factors such as skin moisture levels, melatonin levels, or the like. A further source of error is the presence of inductive coupling between different electrical conductors within the leads, or between the leads themselves.

[0037] Such external factors can lead to inaccuracies in the measurement process and subsequent analysis and accordingly, it is desirable to be able to reduce the impact of external factors on the measurement process.

[0038] One form of inaccuracy that can arise is caused by the voltages across the subject being unsymmetrical, a situation referred to as an "imbalance". Such a situation results in a significant signal voltage at the subject's body centre, which in turn results in stray currents arising from parasitic capacitances between the subject's torso and the support surface on which the subject is provided.

[0039] The presence of an imbalance, where the voltage across the subject is not symmetrical with respect to the effective centre of the subject, leads to a "common mode" signal, which is effectively a measure of the signal at the subject S that is unrelated to the subject's impedance. To help reduce this effect, it is therefore desirable for signals to be applied to the subject S that they result in a symmetrical voltage about the subject's body centre. As a result, a reference voltage within the subject S, which is equal to a reference voltage of the measurement apparatus, will be close to the effective body centre of the subject, as considered relative to the electrode placement. As the measuring device reference voltage is typically ground, this results in the body centre of the subject S being as close to ground as possible, which minimises the overall signal magnitude across the subject's torso, thereby minimising stray currents.

[0040] In one example, a symmetrical voltage about the sensing electrodes can be achieved by using a symmetrical voltage source, such as a differential bidirectional voltage drive scheme, which applies a symmetrical voltage to each of the drive electrodes 113A, 113B. However, this is not always effective if the contact impedances for the two drive electrodes 113A, 113B are unmatched, or if the impedance of the subject S varies along the length of the subject S, which is typical in a practical environment.

[0041] The apparatus of the present invention overcomes this by adjusting the differential voltage drive signals applied

to each of the drive electrodes 113A, 113B, to compensate for the different electrode impedances, and thereby restore the desired symmetry of the voltages across the subject S. This process is referred to herein as *balancing* and in one example, helps reduce the magnitude of the common mode signal, and hence reduce current losses caused by parasitic capacitances associated with the subject.

5 [0042] The degree of imbalance, and hence the amount of balancing required, can be determined by monitoring the signals at the sense electrodes 115A, 115B, and then using these signals to control the signal applied to the subject via the drive electrodes 113A, 113B. In particular, the degree of imbalance can be calculated by determining an additive voltage from the voltages detected at the sense electrodes 115A, 115B.

10 [0043] In one example process, the voltages sensed at each of the sense electrodes 115A, 115B are used to calculate a first voltage, which is achieved by combining or adding the measured voltages. Thus, the first voltage can be an additive voltage (commonly referred to as a common mode voltage or signal) which can be determined using a differential amplifier.

[0044] In this regard, a differential amplifier is typically used to combine two sensed voltage signals V_a , V_b , to determine a second voltage, which in one example is a voltage differential $V_a - V_b$ across the points of interest on the subject S. The voltage differential is used in conjunction with a measurement of the current flow through the subject to derive impedance values. However, differential amplifiers typically also provide a "common mode" signal $(V_a + V_b)/2$, which is a measure of the common mode signal.

15 [0045] Whilst differential amplifiers include a common mode rejection capability, this is generally of only finite effect and typically reduces in effectiveness at higher frequencies, so a large common mode signal will produce an error signal superimposed on the differential signal.

20 [0046] The error caused by common mode signals can be minimised by calibration of each sensing channel. In the ideal case where both inputs of a differential amplifier are perfectly matched in gain and phase characteristics and behave linearly with signal amplitude, the common mode error will be zero. In one example, the two sensing channels of the differential amplifier are digitised before differential processing. It is therefore straightforward to apply calibration factors independently to each channel to allow the characteristics to be matched to a high degree of accuracy, thereby achieving a low common mode error.

25 [0047] Accordingly, by determining the common mode signal, the applied voltage signals can be adjusted, for example by adjusting the relative magnitude and/or phase of the applied signals, to thereby minimise the common mode signal and substantially eliminate any imbalance.

30 [0048] An example of the operation of the apparatus of Figure 1 to perform this will now be described with reference to Figure 2.

[0049] At step 200, a first signal is applied to the subject S, with a second signal measured across the subject S being determined at step 210. This will typically be achieved using the techniques outlined above. Accordingly, the processing system 102 will cause the signal generators 117A, 117B to generate the first signal, which is typically applied to the subject S via the first electrodes 113A, 113B. Similarly the second signal will be sensed by the sensors 118A, 118B, via the second electrodes 115A, 115B, with an indication of the second signal being provided to the processing system 102.

35 [0050] At step 220, an imbalance is determined by the processing system 102 using the second signal sensed at the second electrodes 115A, 115B, which in one example represents a common mode signal.

[0051] At step 230, the measuring device optionally adjusts the first signal applied to the subject S, so as to reduce the imbalance and hence the magnitude of the common mode signal. Thus, the magnitude of the signal applied at either one of the first electrodes 113A, 113B can be adjusted, for example by increasing or decreasing the relative signal magnitudes and/or altering the relative signal phases, so as to balance the signal within the subject and centralise the position of the reference voltage within the subject relative to the electrode positioning.

40 [0052] At step 240, the measuring device can then determine the signal applied to the subject and the voltages measured at the electrodes 113A, 113B, thereby allowing an impedance to be determined at step 250.

45 [0053] As the position of the reference voltage within the subject S is impedance dependent, the imbalance will typically vary depending on the frequency of the applied signal. Accordingly, in one example, it is typical to determine the imbalance and adjust the applied signal at each applied frequency. However, this may depend on the preferred implementation.

[0054] A specific example of the apparatus will now be described in more detail with respect to Figure 3.

50 [0055] In this example, the measuring system 300 includes a computer system 310 and a separate measuring device 320. The measuring device 320 includes a processing system 330 coupled to an interface 321 for allowing wired or wireless communication with the computer system 310. The processing system 330 may also be optionally coupled to one or more stores, such as different types of memory, as shown at 322, 323, 324, 325, 326.

55 [0056] In one example, the interface is a Bluetooth stack, although any suitable interface may be used. The memories can include a boot memory 322, for storing information required by a boot-up process, and a programmable serial number memory 323, that allows a device serial number to be programmed. The memory may also include a ROM (Read Only Memory) 324, flash memory 325 and EPROM (Electrically Programmable ROM) 326, for use during operation. These may be used for example to store software instructions and to store data during processing, as will be appreciated by persons skilled in the art.

[0057] A number of analogue to digital converters (ADCs) 327A, 327B, 328A, 328B and digital to analogue converters (DACs) 329A, 329B are provided for coupling the processing system 330 to the sensors 118A, 118B and the signal generators 117A, 117B, as will be described in more detail below.

[0058] A controller (not shown), such as a microprocessor, microcontroller or programmable logic device, may also be provided to control activation of the processing system 330, although more typically this is performed by software commands executed by the processing system 330.

[0059] An example of the computer system 310 is shown in Figure 4. In this example, the computer system 310 includes a processor 400, a memory 401, an input/output device 402 such as a keyboard and display, and an external interface 403 coupled together via a bus 404, as shown. The external interface 403 can be used to allow the computer system to communicate with the measuring device 320, via wired or wireless connections, as required, and accordingly, this may be in the form of a network interface card, Bluetooth stack, or the like.

[0060] In use, the computer system 310 can be used to control the operation of the measuring device 320, although this may alternatively be achieved by a separate interface provided on the measuring device 300. Additionally, the computer system can be used to allow at least part of the analysis of the impedance measurements to be performed.

[0061] Accordingly, the computer system 310 may be formed from any suitable processing system, such as a suitably programmed PC, Internet terminal, lap-top, hand-held PC, smart phone, PDA, server, or the like, implementing appropriate applications software to allow required tasks to be performed.

[0062] In contrast, the processing system 330 typically performs specific processing tasks, to thereby reduce processing requirements on the computer system 310. Thus, the processing system typically executes instructions to allow control signals to be generated for controlling the signal generators 117A, 117B, as well as the processing to determine instantaneous impedance values.

[0063] In one example, the processing system 330 is formed from custom hardware, or the like, such as a Field Programmable Gate Array (FPGA), although any suitable processing module, such as a magnetologic module, may be used.

[0064] In one example, the processing system 330 includes programmable hardware, the operation of which is controlled using instructions in the form of embedded software instructions. The use of programmable hardware allows different signals to be applied to the subject S, and allows different analysis to be performed by the measuring device 320. Thus, for example, different embedded software would be utilised if the signal is to be used to analyse the impedance at a number of frequencies simultaneously as compared to the use of signals applied at different frequencies sequentially.

[0065] The embedded software instructions used can be downloaded from the computer system 310. Alternatively, the instructions can be stored in memory such as the flash memory 325 allowing the instructions used to be selected using either an input device provided on the measuring device 320, or by using the computer system 310. As a result, the computer system 310 can be used to control the instructions, such as the embedded software, implemented by the processing system 330, which in turn alters the operation of the processing system 330.

[0066] Additionally, the computer system 310 can operate to analyse impedance determined by the processing system 330, to allow biological parameters to be determined.

[0067] Whilst an alternative arrangement with a single processing system may be used, the division of processing between the computer system 310 and the processing system 330 can provide some benefits.

[0068] Firstly, the use of the processing system 330 allows the custom hardware configuration to be adapted through the use of appropriate embedded software. This in turn allows a single measuring device to be used to perform a range of different types of analysis.

[0069] Secondly, this vastly reduces the processing requirements on the computer system 310. This in turn allows the computer system 310 to be implemented using relatively straightforward hardware, whilst still allowing the measuring device to perform sufficient analysis to provide interpretation of the impedance. This can include for example displaying information such as relative fluid levels, body composition parameters, a "Wessel" plot, or other indicators, as well as using the impedance values to determine parameters relating to cardiac function, the presence, absence or degree of lymphoedema, oedema, or the like.

[0070] Thirdly, this allows the measuring device 320 to be updated. Thus for example, if an improved analysis algorithm is created, or an improved current sequence determined for a specific impedance measurement type, the measuring device can be updated by downloading new embedded software via flash memory 325 or the external interface 321.

[0071] In use, the processing system 330 generates digital control signals, indicative of the voltage drive signals V_{DA} , V_{DB} to be applied via the drive electrodes 113A, 113B, which are converted to analogue control signals by the DACs 329. The analogue control signals are transferred to the signal generators 117, allowing voltage drive signals V_{DA} , V_{DB} to be generated by each of the signal generators 117A, 117B.

[0072] Analogue signals representing sensed current signals I_{SA} , I_{SB} , induced by the voltage drive signals V_{DA} , V_{DB} are received from the signal generators 117A, 117B and digitised by the ADCs 328A, 328B. Similarly, analogue signals representing sensed voltages V_{SA} , V_{SB} measured at the second electrodes 115A, 115B are received from the sensors 118A, 118B and digitised by the ADCs 327A, 327B. The digital signals can then be returned to the processing system

330 for preliminary analysis.

[0073] In this example, a respective set of ADCs 327, 328, and DACs 329 are used for each of two channels, as designated by the reference numeral suffixes A, B respectively. This allows each of the signal generators 117A, 117B to be controlled independently and for the sensors 118A, 118B to be used to detect signals from the electrodes 115A, 115B separately. This therefore represents a two channel device, each channel being designated by the reference numerals A, B. It will be appreciated that similarly, voltage drive signals V_D , sensed current signals I_S , and sensed voltage signals V_S can also similarly be identified by a suffix A, B, representing the respective channel.

[0074] In practice, any number of suitable channels may be used, depending on the preferred implementation. Thus, for example, it may be desirable to use a four channel arrangement, in which four drive and four sense electrodes are provided, with a respective sense electrode and drive electrode pair 113, 115 being coupled to each limb. In this instance, it will be appreciated that an arrangement of eight ADCs 327, 328, and four DACs 329 could be used, so each channel has respective ADCs 327, 328, and DACs 329. Alternatively, other arrangements may be used, such as through the inclusion of a multiplexing system for selectively coupling a two-channel arrangement of ADCs 327, 328, and DACs 329 to a four channel electrode arrangement, as will be appreciated by persons skilled in the art.

[0075] Additional channels may also be provided for performing additional measurements at other locations on the subject, such as to allow direct measurement of voltages at the shoulder, the hip or a variety of abdominal locations.

[0076] An example of the functionality implemented by the processing system 330 will now be described with reference to Figure 5. In this example the processing system 330 implements the functionality using appropriate software control, although any suitable mechanism may be used. In this example the processing system 330 includes a timing and control module 500, a messaging module 501, an analysis module 502, sine wave look up tables (LUTs) 503, 504, a current module 505, and a voltage module 506.

[0077] In use, the processing system 330 receives information representing the frequency and amplitude of signals to be applied to the subject S from the computer system 310, via the external interface 321. The timing and control module 500 uses this information to access the LUTs 503, 504, which in turn cause a digital sine wave signal to be produced based on the specified frequency and amplitude. The digital control signals are transferred to the DAC's 329A, 329B, to thereby allow analogue control signals indicative of the voltage drive signals V_{DA} , V_{DB} to be produced.

[0078] Measured analogue voltage and current signals V_{SA} , V_{SB} , I_{SA} , I_{SB} are digitised by the ADC's 327, 328 and provided to the current and voltage modules 505, 506. This allows the processing system 330 to determine the current flow by having the current module 505 determine the total current flow through the subject using the two current signals I_{SA} , I_{SB} , with an indication of this being provided to the analysis module 502. The voltage module 506, which is typically in the form of a differential voltage amplifier, or the like, operates to determine a differential voltage, which is also transferred to the analysis module 502, allowing the analysis module to determine impedance values using the current and differential voltage signals.

[0079] In addition to this, the voltage module 506 determines a common mode signal, which is returned to the timing and control module 500. This allows the timing and control module 500 to determine any imbalance in the voltage sensed at the subject S, which as mentioned above is indicative of the reference voltage not being positioned centrally within the subject S, with respect to the electrodes.

[0080] If the degree of imbalance is unacceptable the timing and control module 500 can adjust the relative amplitude and/or phase of the sine waves representing the voltage drive signals V_{DA} , V_{DB} as will be described below, allowing a new differential voltage, hence indication of any imbalance, to be determined.

[0081] Once the imbalance is determined to be acceptable the timing and control module 500 can provide an indication of this to the analysis module 502, allowing this to use appropriate analysis, such as phase quadrature extraction, to determine a ratio and phase difference for the measured impedance, based on the current flow through the subject and the differential voltage signals. The ratio and phase can then be transferred to the messaging module 510 allowing an indication of measured impedance to be provided to the computer system 310 via the interface 321.

[0082] The processing system 330 may also implement a signal level fault detection module 508. This monitors the magnitude of signals applied to the subject to determine if these are within acceptable threshold levels. If not, the fault detection module 508 can cause a message to be transferred to the computer system 310 to allow the process to be halted or to allow an alert to be generated.

[0083] During this process, any measurements made, including raw current and voltage signals, may be stored in a suitable one of the memories 322, 323, 324, 325, 326, or otherwise output, allowing this to be used to monitor device operation. This can be used in performing diagnostics, as well as calibration of the device.

[0084] An example of the process for performing impedance measurements will now be described with reference to Figure 6A to 6C.

[0085] At step 600 the computer system 310 is used to select an impedance measurement type, with this triggering the computer system 310 to cause desired instructions, such as embedded software, to be implemented by the processing system 330. It will be appreciated that this may be achieved in a number of manners, such as by downloading required embedded software from the computer system 310 to the processing system 330 or alternatively by having the processing

system 330 retrieve relevant embedded software from internal memory or the like.

[0086] At step 610 the computer system 310 or the processing system 330 selects a next measurement frequency f_i , allowing the processing system 330 to generate a sequence of digital voltage control signals at step 615, as described above. The digital control signals are converted to analogue control signals indicative of the voltage drive signals V_{DA} , V_{DB} using the DACs 329A, 329B at step 620. This allows the analogue control signals to be provided to each of the signal generators 117A, 117B at step 625, causing each signal generator 117A, 117B to generate respective voltage drive signals V_{DA} , V_{DB} and apply these to the subject S at step 630, via the respective drive electrodes 113A, 113B.

[0087] At step 635 the voltage induced across the subject is determined by having the sensors 118A, 118B sense voltages V_{SA} , V_{SB} at the sense electrodes, 115A, 115B, with the sensed voltage signals V_{SA} , V_{SB} being digitised by the corresponding ADC 327A, 327B at step 640. At step 645 current signals I_{SA} , I_{SB} , caused by application of the voltage drive signals V_{DA} , V_{DB} , are determined using the signal generators 117A, 117B. An indication of the current signals I_{SA} , I_{SB} are transferred to the ADCs 328A, 328B for digitisation at step 650.

[0088] At step 655 the digitised current and voltage signals I_{SA} , I_{SB} , V_{SA} , V_{SB} are received by the processing system 330 allowing the processing system 330 to determine the magnitude of the applied current I_S at step 660. This may be performed using the current addition module 505 in the above described functional example of Figure 5, allowing the fault detection module 508 to compare the total current flow I_S through the subject to a threshold at step 665. If it is determined that the threshold has been exceeded at step 670 then the process may terminate with an alert being generated at step 675.

[0089] This situation may arise, for example, if the device is functioning incorrectly, or there is a problem with connections of electrodes to the subject, such as if one is not in correct electrical contact with the subject's skin. Accordingly, the alert can be used to trigger a device operator to check the electrode connections and/or device operation to allow any problems to be overcome. It will be appreciated, that any suitable form of corrective action may be taken such as attempting to restart the measurement process, reconnecting the electrodes to the subject S, reducing the magnitude of the current through the subject, or the like.

[0090] At step 680 the processing system 330 operates to determine a common mode voltage based on the amplitude of the sensed voltages V_{SA} , V_{SB} sensed at each of the electrodes 115A, 115B, and this is typically achieved using the voltage processing module 506 in the above functional example. The common mode voltage or common mode signal is then used to determine any imbalance at step 685.

[0091] At step 690 an assessment is made as to whether the imbalance is acceptable. This may be achieved in any one of a number of ways, such as by comparing the amplitude of the common mode signal to a threshold, or the like. The threshold will generally be previously determined and stored in one of the memories 324, 325, 326, for example during device manufacture or calibration.

[0092] In the event that the imbalance is deemed to not be acceptable, then at step 695 the processing system 330 modifies the digital control signals representing the voltage drive signals V_{DA} , V_{DB} to reduce the imbalance. This is typically achieved by having the processing system 330 implement an algorithm that adjusts the applied voltage drive signals V_{DA} , V_{DB} to maintain the common mode voltage at the centre of the body as close to the device reference voltage as possible. This is generally achieved by adjusting the amplitude and/or phase of the voltage drive signals V_{DA} , V_{DB} applied to the subject, using the algorithm. The nature of this adjustment will depend on the nature of the imbalance, and an example algorithm will be described in more detail below.

[0093] The process can then return to step 620 to allow the modified digital control signals to be converted to analogue signals using DACs 324, with modified voltage drive signals V_{DA} , V_{DB} being applied to the drive electrodes 113A, 113B. This process is repeated until an acceptable balance is achieved.

[0094] Once an acceptable balance is achieved, the processing system 330 operates to determine the differential voltage sensed across the subject at step 700. In the functional example described above with respect to Figure 5, this can be achieved using the differential voltage module 506. At step 705 the processing module 330 operates to determine ratio and phase signals, representing the impedance of the subject S, at the applied frequency f_i using the current and differential voltage signals. In the above functional example, this can be performed using the analysis module, and some form of signal analysis, such as phase quadrature analysis, depending on the preferred implementation. At step 710, an indication of the ratio and phase signals are sent to the computer system 310 for further processing.

[0095] Once this is completed the process may return to step 610 to allow the process to be repeated at a next measurement frequency f_i , otherwise if all required frequencies are complete, the measurement process can terminate, allowing the computer system 310 to analyse the impedance measurements, and determine required information, such as any biological indicators, impedance parameters, or the like. The manner in which this is achieved will depend on the type of analysis being performed.

[0096] Accordingly, it will be appreciated that by repeating the above described process this allows a number of impedance measurements to be performed over a range of different frequencies. Furthermore, prior to at least one, and more typically, to each measurement, a check can be performed to ensure that the common mode of the subject and the device are approximately matched, thereby reducing inaccuracies in the measurement procedure.

[0097] Figure 7A is an example of an electrode system for a single one of the channels, which incorporates both a drive electrode 113 and sense electrode 115.

[0098] The electrode system incorporates a first substrate 750, such as a printed circuit board (PCB), or the like, having the respective signal generator 117 and sensor 118 mounted thereon. The general functionality of the signal generator 117 and sensor 118 are represented by the components shown. In practice a greater number of components may be used in a suitable arrangement, as would be appreciated by persons skilled in the art, and the components shown are merely intended to indicate the functionality of the signal generator and the sensor 117, 118. The substrate 750 and associated components may be provided in a suitable housing to protect them during use, as will be appreciated by persons skilled in the art.

[0099] The signal generator 117 and the sensor 118 are coupled via respective cables 761, 762 to conductive pads 763, 765, which may be mounted on a second substrate 760, and which form the first and second electrodes 113, 115, respectively. It will be appreciated that in use, the cables 761, 762 may include clips or the like, to allow the conductive pads to be easily replaced after use.

[0100] As will be appreciated, the conductive pads are typically formed from a silver pad, having a conductive gel, such as silver/silver chloride gel, thereon. This ensures good electrical contact with the subject S.

[0101] The conductive pads may be mounted on the substrate 760, so as to ensure that the conductive pads 763, 765 are positioned a set distance apart in use, which can help ensure measurement consistency. Alternatively the conductive pads 763, 765 can be provided as separate disposable conductive pads, coupled to the first substrate 750 by cables 761, 762. Other suitable arrangements may also be used.

[0102] In one example, the substrate 760 is formed from a material that has a low coefficient of friction and/or is resilient, and/or has curved edges to thereby reduce the chances of injury when the electrodes are coupled to the subject. The substrate 760 is also typically arranged to facilitate electrical contact between the conductive pads 763, 765 and the subject's skin at the typical measurement sites, such as the wrist and ankle. This can be achieved by providing a substrate 760 that adapts to, or is shaped to conform with the irregular shapes and angles of the anatomy.

[0103] In this example, the signal generator 117 includes an amplifier A_1 having an input coupled to a cable 751. The input is also coupled to a reference voltage, such as ground, via a resistor R_1 . An output of the amplifier A_1 is connected via a resistor R_2 , to a switch SW , which is typically a CMOS (complementary metal-oxide semiconductor) switch or a relay that is used to enable the voltage source. The switch SW is controlled via enabling signals EN received from the processing system 330 via a cable 752.

[0104] The switch SW is in turn coupled via two resistors R_3, R_4 , arranged in series, and then, via the cable 761, to the conductive pad 763. A second amplifier A_2 is provided with inputs in parallel with the first of the two series resistor R_3 and with an output coupled via a resistor R_5 , to a cable 753.

[0105] It will be appreciated from the above that the cables 751, 752, 753 therefore forms the lead 123 of Figure 1. A range of different resistor values may be used, but in one example, the resistors have values of $R_1 = R_2 = R_5 = 50\Omega$, and $R_3 = R_4 = 100\Omega$.

[0106] The sensor 118 generally includes an amplifier A_3 having an input connected via a resistor R_6 , to the cable 762. The input is also coupled via a resistor R_7 , to a reference voltage such as a ground. An output of the amplifier A_3 is coupled to a cable 754, via a resistor R_7 .

[0107] It will be appreciated from the above that the cable 754 therefore forms the lead 125 of Figure 1. A range of different resistor values may be used, but in one example, the resistors have values of $R_6 = 100\Omega$, $R_7 = 10M\Omega$ and, $R_8 = 50\Omega$.

[0108] Optional power cables 755 can be provided for supplying power signals $+Ve$, $-Ve$, for powering the signal generator 117 and the sensor 118, although alternatively an on board power source such as a battery, may be used. Additionally, a cable 756 may be provided to allow an LED 757 to be provided on the substrate 750. This can be controlled by the processing system 330, allowing the operating status of the electrode system to be indicated.

[0109] Operation of the signal generator 117 and the sensor 118 will now be described in more detail. For the purpose of this explanation, the voltage drive signal, current signal and sensed voltage will be generally indicated as V_D , I_S , V_S , and in practice, these would be equivalent to respective ones of the voltage drive signals, current signals and sensed voltages V_{DA} , V_{DB} , I_{SA} , I_{SB} , V_{SA} , V_{SB} in the example above.

[0110] In use, the amplifier A_1 operates to amplify the analogue voltage signal received from the DAC 329 and apply this to the subject S via the cable 761, so that the applied voltage drive signal V_D drives a current signal I_S through the subject S. The voltage drive signal V_D , will only be applied if the switch SW is in a closed position and the switch SW can therefore be placed in an open position to isolate the voltage source from the subject S. This may be used if a pair of drive and sense electrodes 113, 115 are being used to sense voltages only, and are not being used to apply a voltage drive signal V_D to the subject S. Isolating the signal generator 117 from the drive electrode 113 removes the unintended return current path(s) that would otherwise be present due to the low output impedance of the amplifier A_1 , thereby constraining current to flow only between the two selected drive electrodes 113. Other techniques may be used to achieve a similar effect, such as using an amplifier incorporating a high impedance output-disable state.

[0111] The current signal I_S being applied to the subject S is detected and amplified using the amplifier A_2 , with the amplified current signal I_S being returned to the processing system 330, along the cable 753 and via the ADC 328.

[0112] Similarly, the sensor 118 operates by having the amplifier A_3 amplify the voltage detected at the second electrode 115, returning the amplified analogue sensed voltage signal V_S along the cable 754, to the ADC 327.

[0113] The cables 751, 752, 753, 754, 755, 756 may be provided in a number of different configurations depending on the preferred implementation. In one example, each of the cables 751, 752, 753, 754, 755, 756 are provided in a single lead L, although this is not essential, and the cables could be provided in multiple leads, as will be described in more detail below.

[0114] Another potential source of error is caused by cross electrode capacitive coupling. As shown in Figure 7B, the relative proximity of the electrodes 113, 115 and the corresponding connections 761, 762, results in an effective capacitance C_{DS} , between the output of the drive amplifier A_1 and the input of the sense amplifier A_3 . Accordingly, this will cause a parasitic current flow between the amplifiers electrodes A_1 , A_3 , which can in turn result in inaccuracies in the measurements, particularly at higher frequencies.

[0115] To cancel the cross electrode capacitive coupling a cross electrode capacitance cancelling circuit is provided, as shown in Figure 7C, which shows an equivalent circuit modelling the electrical responsiveness of the electrodes 113, 115 in use.

[0116] In this example, the impedances of each electrode 113, 115 and the subject S are represented by respective impedances Z_{113} , Z_{175} , Z_S , formed by respective resistor and capacitor arrangements. The cross electrode capacitance cancelling circuit 770 is coupled to the output of the drive amplifier A_1 and the input of the sense amplifier A_3 , and includes an inverting amplifier A_4 , having an input coupled to the output of the drive amplifier A_1 . The output of the inverting amplifier is connected in series via a resistor R_{10} and a capacitor C_{10} , to the input of the sense amplifier A_3 .

[0117] In this arrangement any signal output from the drive amplifier A_1 will be inverted and then applied to the input of the sense amplifier A_3 . By selecting appropriate values for the resistor R_{10} and a capacitor C_{10} , this allows the inverted signal to have a magnitude equal to the magnitude of any signal resulting from the effective cross electrode capacitance C_{DS} .

[0118] In one example, the resistance and/or capacitance of the resistor R_{10} and capacitor C_{10} respectively, can be adjusted, through the use of suitable adjustable components, such as a variable resistor or capacitor. This allows the magnitude and/or phase of the inverted signal to be controlled so that it effectively cancels the signal resulting from the effective cross electrode capacitance C_{DS} . It will be appreciated that adjustment of the components may be performed during a calibration process, which will typically include the complete electrode unit together with its associated electrodes attached so that all parasitic capacitances are accurately represented.

[0119] Accordingly, the cross electrode capacitance cancelling circuit 770 provides an effective negative capacitance between the drive electrode 113 and corresponding sense electrode 115, so that a negative current flow occurs, thereby cancelling the parasitic current. This therefore negates the effect of any capacitive coupling between the drive and sense electrodes 113, 115. The electrode system may also include an input capacitance cancelling circuit, an example of which is shown in Figure 7D.

[0120] In use, the sense electrodes 115 can capacitively couple to the environment, which results in an effective input capacitance C_{EI} at the input of the sense amplifier A_3 . The effective capacitance allows signal leakage from the input of the sense amplifier to ground, thereby reducing the signal available at the amplifier input.

[0121] Accordingly, in this example, an input capacitance cancelling circuit 780 is provided which connects the positive amplifier input of the sense amplifier A_3 to the output of the sense amplifier, via a resistor R_{11} and a capacitor C_{11} . This acts as a positive feedback loop, allowing a proportion of the amplified signal to be returned to the amplifier input. This acts to cancel the reduction in signal at the amplifier input that is caused by the effective input capacitance C_{EI} , and therefore provides an effective negative capacitance that cancels the effect of the effective input capacitance C_{EI} at the amplifier input. Again, the input capacitance cancelling circuit requires tuning, which can be achieved during calibration by suitable adjustment of the values of the resistor R_{11} and/or the capacitor C_{11} .

[0122] As briefly mentioned above, when separate leads 123, 125, are used for the voltage signal V_S and the current signal I_S , then inductive coupling between the leads 123, 125 can result in EMFs being induced within the leads 123, 125. The magnitude of the EMF is dependent on the degree of coupling between the leads 123, 125 and hence their physical separation, and also increases in proportion to the frequency and amplitude of the current signal I_S .

[0123] The EMF induced within the leads 123, 125 results in an effective EMF across the input of the sensor 118. As a result, a component of the sensed voltage signal V_S is due to the induced EMF, which in turn leads to inaccuracies in the determined voltage signal V_S and the current signal I_S .

[0124] The effect of inductive coupling varies depending on the physical separation of the leads 123, 125. Accordingly, in one example, the effect of inductive coupling between leads can be reduced by physically separating the leads as much as possible. Thus, in one example, the cables 751, 752, 753, 754, 755, 756 are provided in separate physically separated leads. However, a problem with this arrangement is that the amount of inductive coupling will vary depending on the physical lead geometry, which can therefore vary between measurements. As a result, the magnitude of any

inductive coupling can vary, making this difficult to account for when analysing the impedance measurements.

[0125] An alternative to using physically separate leads for each of the cables 751, 752, 753, 754, 755, 756 is to use a single combined lead L. The lead is formed so that the cables 751, 752, 753, 754, 755, 756 are held in a substantially constant relative physical configuration. In one example, the leads L are formed so as to provide a constant geometric arrangement by twisting each of the respective cables together. However, alternative fabrication techniques could be used such as making the leads from separate un-insulated shielded cables that are over moulded to maintain close contact.

[0126] As a result of the constant physical geometry, any EMF induced along the leads 123, 125 is substantially constant, allowing this to be accounted for during a calibration process.

[0127] Accordingly, when the measuring device 320 is initially configured, and in particular, when the algorithms are generated for analysing the voltage and current signals V_S , I_S , to determine impedance measurements, these can include calibration factors that take into account the induced EMF. In particular, during the configuration process, a measuring device 320 can be used to take measurements from reference impedances, with the resulting calculations being used to determine the effect of the induced EMF, allowing this to be subtracted from future measurements.

[0128] A further issue with the lead arrangement is that of capacitive coupling between the respective cables, as will now be described with respect to Figure 8. For the purpose of this example, only cables 751, 753, 754 are shown for clarity.

[0129] In this example, the measuring device 320 is connected to the PCB's 750A, 750B to provide connections for each of the electrodes 113A, 113B, 115A, 115B. As also shown, each of the cables 751, 753, 754 have respective shielding 851, 853, 854 provided thereon. The shielding is used to help prevent coupling between the respective cables 751, 753, 754. It will therefore be appreciated that the cables 751, 753, 754 are generally formed from a shielded wire core. In practice, the shielded cables may be 50Ω transmission lines, which minimize signal transmission distortion at high frequencies, thereby minimizing errors. In addition to this, the shields 851, 853, 854 are typically interconnected at each end, to a reference voltage such as a ground, via respective connections 855, 856.

[0130] The use of shielded and grounded cables in this fashion helps reduce the effect of capacitive coupling, helping to further reduce inaccuracies in obtained measurements.

[0131] A further potential issue is that of inductive coupling between the different leads L, as well as capacitive coupling between the subject and the subject and the bed. In this regard, parasitic capacitances allow high frequency currents to bypass the intended current path through the body, resulting in measurement errors. To take this into account, in one example, the leads L for each electrode system can be physically separated as much as possible and/or provided in an arrangement that minimizes lead length in use. An example of an arrangement for achieving this will now be described with respect to Figure 9.

[0132] For the purpose of this example, the measuring system provides four measuring channels, designated by the suffixes A, B, C, D. It will be appreciated that this can be achieved by using a modified version of the measuring device 320 of Figure 3, in which further ADCs 327, 328 and DACs 329 are provided as briefly described above.

[0133] In this example, the subject S is laying on a bed 900, with arms 931, 932 positioned by the subject's side, and the legs 933, 934 resting on a support 940, which incorporates the measuring device 320. The support may be any form of support, but is typically formed from moulded foam, or the like, which arranges the subject with the measuring device 320 positioned substantially between the subject's knees. The measuring device 320 is typically incorporated into the support both to ensure accurate location of the subject relative to the measuring device 320, and also to protect the subject S from damage caused by rubbing or other impact with a housing of the measuring device 320.

[0134] By providing a four channel arrangement, this allows a respective electrode system to be mounted to each of the subject's limbs. Thus, as shown, each limb 931, 932, 933, 934 has a respective substrate 760 mounted thereon, to thereby provide a drive and sense electrode 113, 115 on each wrist and ankle. The electrodes 113, 115, are coupled to respective signal generators and sensors mounted on the substrates 750, which are in turn coupled to the measuring device 320 via respective leads LA, LB, LC, LD.

[0135] The leads are arranged so that each lead LA, LB, LC, LD extends away from the measuring device 320 in different directions, thereby maximizing the physical separation of the leads and hence helping to reduce any inductive coupling therebetween.

[0136] Additionally, the leads LA, LB, LC, LD are preferably adapted to extend perpendicularly from both the measuring device 320 and the subject S, to thereby further reduce the effects of capacitive coupling.

[0137] Furthermore, by having the measuring device 320 positioned near the subject's knee, this places the measuring device 320 approximately equi-distant between the subject's wrists and ankles. Thus, by arranging the measuring device 320 towards the lower end of the bed 900, this reduces the length of leads LA, LB, LC, LD needed to place the electrodes on the wrist and ankle of the subject S, whilst maintaining substantially equal lead lengths, which helps further reduce both inductive and capacitive coupling effects. In this regard, the EMF originating from any inductive coupling effect is proportional to the relevant lead length, thereby equalising any effect for the different leads. Similarly, capacitive coupling between the leads (ground) and the subject S, which can create current shunt paths, is also minimized.

[0138] The above described arrangement is for the purpose of example only, and it will be appreciated that in practice,

any suitable mechanisms for positioning the measuring device 320 in the vicinity of the subject's upper legs (approximately midway between the wrists and ankles) can be used. Thus, for example, this could involve simply resting the measuring device 320 on the subject's legs, providing a custom built support, or the like.

[0139] It will be appreciated that in this arrangement, by having four first electrodes and four second electrodes positioned on the limbs, this allows a range of different limb and/or whole body impedance measurements to be performed.

[0140] The electrode configuration shown in Figure 9 can be used to perform an alternative balancing process, as will now be described with reference to Figures 10A and 10B.

[0141] For the purpose of these examples, the subject S has arms 1031 1032, legs 1033, 1034 and a torso 1035 and the measuring device 300 (not shown for clarity) is provided in a multi-channel configuration similar to that shown in Figure 9, with respective pairs of drive and sense electrodes 113A, 115A; 113B, 115B; 113C, 115C; 113D, 115D provided on the wrist and ankles of the subject. In Figures 10A and 10B, active electrodes only are shown.

[0142] In each example, a drive electrode configuration is used that applies a drive signal to the drive electrodes 113B, 113D, so that the signal passes through the arm 1031, the torso 1035 and the leg 1033, as shown by the dotted line 1040.

[0143] In the example of Figure 10A sense electrodes 115B, 115D provided on the arm 1031 and on the leg 1033 are used to perform the balancing. In contrast, in the arrangement of Figure 10B, the sense electrodes 115A, 115C provided on the contra-lateral limbs 1032, 1034 are used to perform balancing. This leads to different effective electrical models for the balancing process, as shown in Figure 10C. The effective electrical model represents impedances encountered by the drive signal, including impedances Z_{113B} , Z_{113D} , Z_{1031} , Z_{1035} , Z_{1033} , representing the impedances of the drive electrode impedances 113B, 113D, the arm 1031, the torso 1035 and the leg 1033, respectively.

[0144] In the electrode configuration of Figure 10A, the sense electrodes are provided on the arm 1031 and the leg 1033, so that voltages induced within the subject are effectively sensed at the points between the drive electrodes 113B, 113D and the respective limb 1031, 1033. The sensed voltages measured at the electrodes 115B, 115D are shown at V_{SB} and V_{SD} , respectively, and these effectively take into account current flow through the arm 1031, the torso 1035 and the leg 1033.

[0145] When performing balancing, the drive signal is controlled to minimise the common mode voltage such that $V_{SB} \approx -V_{SD}$. In this configuration, the effective ground reference voltage V_R is electrically centred between the sensed voltages V_{SB} , V_{SD} , such that the differences ΔV_B , ΔV_D between the reference voltage V_R and each sensed voltage V_{SB} , V_{SD} is approximately equal $\Delta V_B \approx \Delta V_D$. This therefore takes into account differences in impedances for the drive electrodes 113B, 113D, which typically arise from different contact impedances, so that if one of the electrodes has a significantly higher impedance than the other electrode, the signal applied to the body after the electrodes is still symmetrical with respect to the sense electrodes 115B, 115D.

[0146] As the arm impedance of the arm Z_{1031} is generally higher than the torso impedance Z_{1035} and leg impedance Z_{1033} , then generally the signal voltage difference across the arm 1031 is approximately equal to that across the torso 1035 and leg 1033 combined. Consequently, the location of the reference voltage V_R does not generally occur at the geometric centre of the subject's body, but rather occurs somewhere near the shoulder region of the subject S. As a result, the subject's body centre voltage V_C is not necessarily minimised by balancing according to the sensed voltages V_{SB} , V_{SD} and there can be a significant residual signal voltage V at the centre of the subject's torso 1035, which corresponds to the subject's body centre. Thus, the body centre voltage $V_C = V \neq V_R$. The residual signal voltage will result in current flow due to capacitive coupling between the subject and the environment, such as the bed on which the subject is positioned. This in turn impacts on the accuracy of the impedance measurements.

[0147] By contrast, the arrangement shown in Figure 10B senses the voltages in the subject using the sense electrodes 115A, 115C provided on the contralateral limbs 1032, 1034. As there is no current flow through the contralateral limbs 1032, 1034, the contralateral limbs 1032, 1034 are effectively at the same voltage along their entire length (i.e. isopotential). Accordingly, the sense electrodes 115A, 115C effectively measures the voltages at the point where the torso 1035 joins the arm 1031 and the leg 1033 as also shown in Figure 10C.

[0148] In this instance if the balancing is performed, the reference voltage V_R is electrically centred between the sensed voltages V_{SA} , V_{SC} , such that the difference ΔV_A , ΔV_C between the reference voltage V_R and each sensed voltages V_{SA} , V_{SC} is approximately equal $\Delta V_A \approx \Delta V_C$. As the voltage induced by the overall drive signal V_D is measured across the torso only, and as the upper and lower torso have similar impedances, the reference voltage V_R is positioned midway along the torso 1035. As the reference voltage is typically set to 0V, this minimises the amplitude of the signal voltage on the torso 1035, as induced by the drive signal, which in turn reduces the effect of capacitive coupling between the subject and the bed.

[0149] Accordingly, whilst it will be appreciated that balancing can be performed using the configuration of Figure 10A, this typically only takes into account variations in electrode impedances of the drive electrodes 113B, 113D. Whilst this will also generally reduce the overall potential of the subject's torso, and hence reduce the effect of parasitic capacitances, it still does not necessarily result in the voltages in the body being balanced symmetrically with respect to the torso. Accordingly, in one example it is preferred to use the electrode configuration shown in Figure 10B.

[0150] Thus, balancing can be performed for a range of different electrode configuration, including sensing voltages

on the same limbs to which the voltage drive signals are applied. However, in one example, the balancing is performed by passing signals along a first limb, the torso and a second limb with the voltage signals being measured by different third and fourth limbs. By measuring the voltages on different limbs, this ensures that balancing is performed about the subject's torso which in turn results in reduced effect of capacitive coupling between the subject and the environment.

[0151] It will be appreciated that in practice, there will always be some parasitic current flow from the torso even when the centre-body voltage is balanced. This is due to the relatively large physical size of the torso. However, the process of balancing the centre-body voltage attempts to minimise this error and also enables a repeatable reference point to be achieved.

[0152] A further example measurement sequence will now be described in more detail with reference to Figure 11.

[0153] For the purpose of this example, it is again assumed that the device is provided in a multi-channel configuration similar to that shown in Figure 9, with respective pairs of drive and sense electrodes 113A, 115A; 113B, 115B; 113C, 115C; 113D, 115D provided on the wrist and ankles of the subject. In this example, when a measurement process is being performed, a drive electrode configuration is selected at step 1100. This may involve for example selecting the drive electrodes 113B, 113D, although any suitable combination of drive electrodes may be used, depending on the type of impedance measurement to be performed.

[0154] At step 1105 a next measurement frequency is selected, with voltage drive signals V_{DB} , V_{DD} being applied to the subject at 1110. This allows voltages V_{SA} , V_{SB} , V_{SC} , V_{SD} at each sense electrode 115A, 115B, 115C, 115D to be measured by the respective sensors 118A, 118B, 118C, 118D, and current signals I_{SA} , I_{SB} , I_{SC} , I_{SD} , resulting from the voltage drive signals V_{DB} , V_{DD} to be measured by the signal generators 117A, 117B, 117C, 117D, with an indication of the sensed voltage signals V_{SA} , V_{SB} , V_{SC} , V_{SD} and current signals I_{SB} , I_{SD} being transferred to the measuring device 320.

[0155] The indication of each of the signals is then typically stored at step 1115. This information can be recorded for a number of purposes and in general, it is easiest to simply record indication of each of the signals, rather selectively record information based on a measurement protocol.

[0156] By recording all signals, including all four sensed current and sensed voltage signals, this also allows a single measurement collection protocol to be performed for a variety of different purposes. The recorded data can then be subsequently analysed in a variety of different manners, depending on the intended measurement to be performed. Thus, for example, recorded data could be analysed to provide information regarding body composition, the presence, absence or degree of oedema, or the like.

[0157] At step 1120 the measuring device 320 determines if the balance is acceptable. Thus, for example, if the voltage drive signals V_{DB} , V_{DD} are being applied via the electrodes 113B, 113D, the measuring device 320 will select the sensed voltages V_{SA} , V_{SC} at the sense electrodes 115A, 115C thereby allowing balancing to be assessed, in a manner similar to that described above. In this instance, an additive voltage $V_{SA} + V_{SC}$ will be determined based on the sensed voltages V_{SA} , V_{SC} . The additive voltage will be compared to a threshold, and if this is below the threshold, this indicates that the balancing is acceptable.

[0158] In the event that the balancing is not acceptable, then the voltage drive signals V_{DB} , V_{DD} applied to the subject S are modified at step 1125. The manner in which the signals are adjusted can depend on the preferred implementation. In one example, the adjustment is performed based on the results of the measurements performed at step 1110.

[0159] Thus, for example, the sensed voltages V_{SA} , V_{SC} can be used to determine a body centre voltage V_C . The sensed current signals I_{SB} , I_{SD} , and voltage drive signals V_{DB} , V_{DD} , applied via each drive electrode 113B, 113D are used together with the body centre voltage V_C to determine upper and lower impedances Z_{upper} , Z_{lower} , which represent the impedance of the subject's body and the drive electrodes 113B, 113D on either side of the body centre. The upper and lower impedances Z_{upper} , Z_{lower} can then be used to determine the modified signals, based on a preferred current flow through the subject.

[0160] An example calculation is shown in more detail below. In this example, the body centre voltage V_C is based on:

$$V_C = (V_{SA} + V_{SC}) / 2 \quad (1)$$

[0161] A current flow through the subject is then determined based on:

$$I = (I_{SB} - I_{SD}) / 2 \quad (2)$$

where: I_{SB} = sensed current flow caused by positive voltage drive signal V_{DB} applied to electrode 113B
 I_{SD} = sensed current flow caused by negative voltage drive signal V_{DD} applied to electrode 113D

[0162] This allows an impedance to be determined for the upper and lower portions of the subject, where:

$$Z_{upper} = (V_{DB} - V_C) / I \quad (3)$$

$$Z_{lower} = (V_{DD} - V_C) / I \quad (4)$$

where: Z_{upper} = upper body and drive electrode 113B impedance

Z_{lower} = lower body and drive electrode 113D impedance

[0163] Following this, an ideal current value I_{ideal} (typically set to 90 μ A RMS to ensure subject safety) is used to determine predicted voltage drive signals that will result in a balanced measurement arrangement, using the equation:

$$V_{DB\ predicted} = I_{ideal} \times Z_{upper} \quad (5)$$

$$V_{DD\ predicted} = I_{ideal} \times Z_{lower} \quad (6)$$

where: $V_{DB\ predicted}$ = predicted ideal voltage drive signal for electrode 113B

$V_{DD\ predicted}$ = predicted ideal voltage drive signal for electrode 113D

[0164] Thus, it will be appreciated that in this example, the modified voltage drive signals applied to the subject S are the predicted ideal voltage $V_{DB\ predicted}$, $V_{DD\ predicted}$. The above described example calculation is for the purpose of example only, and alternative calculations may be used.

[0165] In one example, the calculations are performed on the basis of the magnitude of the signals only. This is because the magnitude of the voltage at the body centre will have the greatest impact on leakage current between the subject and the environment.

[0166] However, balancing the magnitude only can lead to phase differences between the drive signals, which in turn can lead to the body centre voltage V_C including an imaginary component. Examples of this will now be described with reference to Figures 12A to 12F.

[0167] In the example of Figure 12B, the voltages are shown based on the equivalent circuit of Figure 12A, in which the subject is represented by body impedances Z_{B1} , Z_{B2} , positioned either side of the body centre. Electrode impedances are shown as part of the body impedances, with drive voltages V_{DB} , V_{DD} being applied directly to the body impedances Z_{B1} , Z_{B2} as shown.

[0168] As shown in Figure 12B, if drive voltages V_{DB} , V_{DD} including only real components are applied, then the complex nature of the body impedances Z_{B1} , Z_{B2} , will result in a phase shift in the voltages V_{ZB1} , V_{ZB2} across the body impedances Z_{B1} , Z_{B2} . As a result, there exists an imaginary component to the body centre voltage. This residual complex component to the body centre voltage can lead to a leakage current from the body as well as extra common mode error in the sensed voltage signals, thereby making it undesirable.

[0169] However, in the example of Figure 12C, if drive voltages V_{DB} , V_{DD} include imaginary components, representing a respective phase difference between the applied signal, then this ensures that the phase of the voltages at the body centre are matched. This ensures that the magnitude of the body centre voltage V_C , is minimised both in respect of the real and imaginary components.

[0170] An example of this scenario in which electrode impedances Z_{113B} , Z_{113D} , for the drive electrodes 113B, 113D are taken into account are shown in Figures 12D to 12F. Again, it can be seen that introducing a suitable phase change in the drive voltage signals V_{DB} , V_{DD} can result in a body centre voltage that is balanced in respect of both real and imaginary components.

[0171] Accordingly, in another example, the balancing procedure can be performed by representing the voltage signals as complex numbers representing both the magnitude and phase of the voltage signals, and by using a complex representation of the impedance. In this instance, this ensures that both the magnitude and phase of the voltage signals are balanced, thereby ensuring a minimal body centre voltage.

[0172] In general, when modifying the phase of the applied voltage drive signals, the half body impedances are assumed to have symmetrical phase shift relative to the drive. Thus an impedance vector difference of 20° will be resolved as +10° at one drive and -10° at the second drive. By keeping the drives as symmetrical as possible, any leakage current induced by the capacitance of each limb is equalised and thus halved. However, this is not essential, and any method of modifying the phase may be used.

[0173] Following determination of the modified voltage drive signals, steps 1110 to 1120 are repeated using the

modified voltage drive signals, with further modified voltage drive signals being calculated until an acceptable balance situation results. It will be appreciated that the number of iterations required to reach an acceptable balance will depend on how close to a balanced situation the initial drive signals are.

[0174] Whilst, voltage drive signals V_{DB} , V_{DD} having equal magnitudes and/or phase could initially be applied, so that $V_{DB} = -V_{DD}$, this can lead to a relatively large number of different modified signals being tried until a balance condition is reached. As the frequency of the voltage drive signal changes, the body impedance will also change. Accordingly, in one example, for a given frequency f_{i+1} the initially applied drive signals $V_{DB}(f_{i+1})$, $V_{DD}(f_{i+1})$ are calculated based on the signals $V_{DB\ predicted}(f_i)$, $V_{DD\ predicted}(f_i)$ determined for a previous frequency f_i . Thus, the signals $V_{DB\ predicted}(f_i)$, $V_{DD\ predicted}(f_i)$ are used to calculate $Z_{upper}(f_i)$, $Z_{lower}(f_i)$. The complex representation of $Z_{upper}(f_i)$, $Z_{lower}(f_i)$ are used to determine $Z_{upper}(f_{i+1})$, $Z_{lower}(f_{i+1})$ which are in turn used together with the ideal current to calculate initial values for $V_{DB\ predicted}(f_{i+1})$, $V_{DD\ predicted}(f_{i+1})$. These values are used as the initial signals applied to the subject at step 1110 for the next frequency f_{i+1} .

[0175] By using the balance condition determined for a previous frequency as the initial starting point for the balancing algorithm at a next frequency, this significantly reduces the number of iterations required to achieve a balance condition in which $V_C \approx 0$. Typically, using this technique, the balance condition can be determined to less than 0.1% error within three iterations.

[0176] Thus, the first iteration with the voltage drive signals $V_{DB}(f_{i+1})$, $V_{DD}(f_{i+1})$ based on the previously determined modified signals $V_{DB\ predicted}(f_i)$, $V_{DD\ predicted}(f_i)$ typically results in a body centre voltage V_C that is within 10% of that required. Thus, the common mode signal voltage at body centre has a magnitude that is approximately 10% of the signal voltage sensed between V_{SA} , V_{SC} . For the second iteration, the voltage drive signals V_{DB} , V_{DD} can be set to achieve V_C to within 1.0% and the third iteration achieves 0.1% error.

[0177] This can therefore dramatically reduce the time required for a complete frequency sweep. The measurement time can be further optimised by taking into account the amplitude of noise on the measurements. Measurement time is dependent on the number of samples required to achieve the desired accuracy. Increased noise requires more samples, which takes more time. Therefore, if the number of samples is optimised according to measured noise level, measurement times can be further reduced (from what would otherwise need to be a default sample number).

[0178] Once a balance is achieved, the measurements recorded at step 1115 can be used to calculate impedance values at step 1130. It is then assessed whether all frequencies are complete and if not the process returns to step 1105 to select a next measurement frequency. Otherwise it is determined if all drive configurations are complete and if not the process returns to step 1100 to allow an alternative drive configuration to be selected.

[0179] Otherwise the process finishes at step 1145, allowing any determined impedance values to be provided to the processing system 310 for subsequent analysis.

[0180] Persons skilled in the art will appreciate that numerous variations and modifications will become apparent. All such variations and modifications which become apparent to persons skilled in the art, should be considered to fall within the spirit and scope that the invention broadly appearing before described.

[0181] For example, two different approaches to balancing are described above. In the first example, the balancing is performed using sense electrodes attached to the same limbs as the drive electrodes, whereas in the second example, the sense electrodes used for balancing are attached to contralateral limbs. In one example, sense and drive electrode are provided on all limbs, allowing balancing to be performed in a similar manner using any suitable combination of drive and sense electrodes. The electrode combinations used may depend on the impedance measurement being performed.

[0182] Additionally features from different examples above may be used interchangeably or in conjunction, where appropriate. Thus, for example, a range of different techniques are described for minimising errors and these can be used independently of each other, or in conjunction, depending on the particular implementation.

[0183] Furthermore, whilst the above examples have focussed on a subject S such as a human, it will be appreciated that the measuring device and techniques described above can be used with any animal, including but not limited to, primates, livestock, performance animals, such as race horses, or the like.

[0184] The above described processes can be used for diagnosing the presence, absence or degree of a range of conditions and illnesses, including, but not limited to oedema, lymphoedema, body composition, or the like.

Claims

1. Apparatus for use in performing impedance measurements on a subject comprising
 - respective pairs of drive and sensing electrodes for placement on upper and lower limbs of the subject; and
 - a , a processing system configured for:
 - a) causing voltage drive signals to be applied to the subject, via drive electrodes;
 - b) sensing via sensing electrodes current signals through the subject caused by the voltage drive signals;

- c) determining an indication of a second signal across the subject, said indication of said second signal being a body centre voltage at the centre of the subject's torso derived from voltages sensed via sensing electrodes;
- d) using the indication of the second signal to determine if an unacceptable imbalance exists; and,
- e) if an unacceptable imbalance exists:

5

- i) determining modified voltage drive signals in accordance with the determined imbalance by:

- determining upper and lower impedances for the subject using the sensed current signals, the voltage drive signals and the body centre voltage; and,
 - determining modified voltage drive signals using said upper and lower impedances and an ideal current signal indication; and,

10

- ii) causing the modified voltage drive signals to be applied to the subject to thereby allow at least one impedance measurement to be performed.

15

2. Apparatus according to claim 1, wherein the processing system is further configured for carrying out step d) by:

- a) comparing the indication of a second signal to a threshold; and,
- b) determining if an unacceptable imbalance exists depending on the results of the comparison.

20

3. Apparatus according to claim 1 or claim 2, wherein the processing system is further configured for:

- a) determining the voltage sensed at each of the sensing electrodes;
- b) determining an additive voltage; and,
- c) determining the imbalance using the additive voltage.

25

4. Apparatus according to claim 3, wherein the additive voltage is a common mode signal.

5. Apparatus according to any one of the claims 1 to 4, wherein the processing system is for determining the modified voltage drive signals so as to reduce the imbalance.

30

6. Apparatus according to claim 5, wherein the processing system is further configured for modifying the voltage drive signals by modifying at least one of a phase and a magnitude of at least one voltage drive signal applied to at least one of the drive electrodes.

35

7. Apparatus according to any one of the claims 1 to 6, wherein the processing system is further configured for:

- a) causing the voltage drive signal to be applied via drive electrodes coupled to an upper first and a lower second limbs of the subject; and,
- b) determining an indication of the second signal via sensing electrodes coupled to an upper third and a lower fourth limbs of the subject, the third and fourth limbs being different to the first and second limbs.

40

8. Apparatus according to any one of the claims 1 to 7, wherein the processing system is further configured for:

- a) selecting voltage signals sensed at selected ones of the sensing electrodes; and,
- b) determining any imbalance using the selected voltage signals.

45

9. Apparatus according to any one of the claims 1 to 8, wherein the processing system is further configured for:

- a) comparing the sensed current signals to a threshold; and,
- b) selectively halting the impedance measurement process depending on the results of the comparison.

50

10. Apparatus according to any one of the claims 1 to 9, wherein the processing system is further configured for:

- a) causing voltage drive signals to be applied to the subject at a first frequency;
- b) determining an indication of a second signal measured across the subject;
- c) using the indication of the second signal to determine any imbalance;
- d) if no unacceptable imbalance exists, using at least the indication of the second signal to determine at least

55

one impedance value;
e) if an unacceptable imbalance exists:

- i) determining modified voltage drive signals in accordance with the imbalance;
- ii) causing the modified voltage drive signals to be applied to the subject;
- iii) determining a further indication of a modified second signal measured across the subject; and
- iv) repeating steps c) to e) for the indication of the modified second signal;

f) repeating steps a) to e) for at least one second frequency.

11. Apparatus according to any one of claims 1 to 10, wherein the voltage drive signals include first and second voltage drive signals applied to the subject via respective first and second drive electrodes, the first voltage drive signal having a first magnitude and first phase, and the second voltage drive signal having a second magnitude and second phase and wherein the processing system is further configured for determining the modified voltage drive signals by modifying at least one of:

- a) the first phase;
- b) the first magnitude;
- c) the second phase; and,
- d) the second magnitude.

12. Apparatus according to any one of claims 1 to 11, wherein the processing system is further configured for:

- a) causing the modified voltage drive signals to be applied to the subject;
- b) determining sensed voltages measured via respective sensing electrodes;
- c) determining if an unacceptable imbalance exists using the sensed voltages; and,
- d) if an unacceptable imbalance exists:

- i) determining further modified voltage drive signals; and,
- ii) repeating steps (a) to (d) until any imbalance is acceptable.

13. Apparatus according to any one of the claims 1 to 12, wherein the processing system is further configured for performing impedance measurements at multiple frequencies, in turn.

14. Apparatus according to claim 13, wherein the processing system is further configured for:

for a first frequency:

- i) determining modified voltage drive signals that result in an acceptable imbalance; and,
- ii) causing an impedance measurement to be performed using the modified voltage drive signals; and,

b) for a second frequency:

- i) causing voltage drive signals to be applied to the subject said voltage drive signals being based on the modified voltage drive signals determined for the first frequency; and,
- ii) determining if an unacceptable imbalance exists.

15. Apparatus according to claim 14, wherein the processing system is further configured for:

a) for a first frequency:

- i) causing first and second voltage drive signals to be applied to the subject via respective drive electrodes;
- ii) determining modified first and second voltage drive signals that result in an acceptable imbalance, the first voltage drive signal having a first magnitude and first phase, and the second voltage drive signal having a second magnitude and second phase; and,

b) for a second frequency:

- i) causing first and second voltage drive signals to be applied to the subject, the first voltage drive signal having the first magnitude and the first phase, and the second voltage drive signal having the second magnitude and the second phase; and,
- ii) determining if an unacceptable imbalance exists.

5
16. Apparatus according to any one of the claims 1 to 15, wherein the processing system is further configured for:

- a) generating control signals;
- b) transferring the control signals to at least one signal generator thereby causing the voltage drive signals to be applied to the subject;
- c) receiving an indication of the voltage drive signals applied to the subject from the at least one signal generator;
- d) receiving an indication of sensed signals measured across the subject from at least one sensor connected to a sensing electrode; and,
- e) performing at least preliminary processing of the indications to thereby allow impedance values to be determined.

10
17. Apparatus according to any one of the claims 1 to 16, wherein the apparatus includes a differential amplifier for amplifying sensed signals measured at each of two sensing electrodes.

15
20
18. Apparatus according to claim 17, wherein the differential amplifier generates at least one of:

- a) a differential voltage indicative of the voltage measured at the sensing electrodes; and,
- b) a common mode signal indicative of any imbalance.

25
19. Apparatus according to any one of the claims 1 to 18, wherein the apparatus further includes, at least one of:

- a) at least one signal generator for applying the voltage drive signal to the subject via a first electrode; and,
- b) at least one sensor for measuring the sensed signal via sensing electrodes.

30
20. Apparatus according to any one of the claims 1 to 19, wherein the apparatus includes a ¹¹ number of electrode systems, and wherein each electrode system includes:

- a) a sensor;
- b) a signal generator; and,
- c) at least one of:

- i) a capacitive cancelling circuit for cancelling capacitive coupling between drive and sensing electrodes; and,
- ii) an input capacitance cancelling circuit for cancelling an effective input capacitance at a sensor input.

35
40
21. Apparatus according to any one of the claims 1 to 20, wherein the apparatus further includes:

- a) a number of electrode systems, and wherein each electrode system includes a signal generator and sensor; and,
- b) at number of leads for connecting the measuring device to the electrode systems, each lead including:

- i) at least two connections for connecting the measuring device and the signal generator, and the measuring device and the sensor; and,
- ii) a shield for each of the at least two connections, the shields being electrically connected, and connected to a reference voltage in each of the measuring device and the electrode system.

45
50
22. A method for use in performing impedance measurements on a subject, wherein the method includes:
- providing respective pairs of drive and sensing electrodes on upper and lower limbs of the subject; and
- employing a processing system for carrying out the steps of :

- a) causing voltage drive singals to be applied to the subject, via drive electrodes;
- b) sensing via sensing electrodes current signals through the subject caused by the voltage drive signals;
- c) determining an indication of a second signal measured across the subject, the indication of the second signal being a body centre voltage at the centre of the subject's torso derived from voltage sensed via sensing elec-

trodes;

d) using the indication of the second signal to determine any imbalance; and,

e) if an imbalance exists:

5

i) determining modified voltage drive signals in accordance with the imbalance by:

determining upper and lower impedances for the subject using the sensed current signals, the voltage drive signals and the body centre voltage; and,

10

determining modified voltage drive signals said the upper and lower impedances and an ideal current signal indication; and,

ii) causing the modified voltage drive signals to be applied to the subject to thereby allow at least one impedance measurement be performed.

15

Patentansprüche

1. Vorrichtung zur Durchführung von Impedanzmessungen an einer Person, aufweisend:

20

- entsprechende Paare Ansteuer- und Abfühlelektroden zum Anlegen an oberen und unteren Extremitäten der Person; und

- ein Verarbeitungssystem, das für Folgendes ausgelegt ist:

25

a) Veranlassen eines Anwendens von Spannungsansteuersignalen auf die Person über Ansteuerelektroden;

b) Messen von durch die Person verlaufenden Stromsignalen, die durch die Spannungsansteuersignale hervorgerufen sind, über Abfühlelektroden;

30

c) Bestimmen einer Anzeige eines quer durch die Person verlaufenden zweiten Signals, wobei die Anzeige des zweiten Signals eine im Zentrum des Rumpfes der Person vorhandene Körpermittenspannung ist, die von Spannungen abgeleitet wird, die über Abfühlelektroden gemessen sind;

d) Verwenden der Anzeige des zweiten Signals, um zu bestimmen, ob ein unannehmbares Ungleichgewicht vorliegt; und

e) falls ein unannehmbares Ungleichgewicht vorliegt:

35

i) Bestimmen modifizierter Spannungsansteuersignale in Übereinstimmung mit dem bestimmten Ungleichgewicht durch:

Bestimmen oberer und unterer Impedanzen für die Person unter Verwendung der gemessenen Stromsignale, der Spannungsansteuersignale und der Körpermittenspannung; und

40

Bestimmen modifizierter Spannungsansteuersignale unter Verwendung der oberen und unteren Impedanzen und einer Soll-Stromsignal-Anzeige; und

ii) Veranlassen eines Anwendens modifizierter Spannungsansteuersignale auf die Person, um dadurch eine Durchführung wenigstens einer Impedanzmessung zu ermöglichen.

45

2. Vorrichtung nach Anspruch 1, wobei das Verarbeitungssystem ferner dazu eingerichtet ist, Schritt d) auszuführen durch:

50

a) Vergleichen der Anzeige eines zweiten Signals mit einem Schwellwert; und

b) Bestimmen, ob ein unannehmbares Ungleichgewicht vorliegt, in Abhängigkeit von den Ergebnissen des Vergleichs.

3. Vorrichtung nach Anspruch 1 oder Anspruch 2, wobei das Verarbeitungssystem ferner für Folgendes ausgelegt ist:

55

a) Bestimmen der Spannung, die an jeder der Abfühlelektroden gemessen ist;

b) Bestimmen einer additiven Spannung; und

c) Bestimmen des Ungleichgewichts mittels der additiven Spannung.

EP 2 211 714 B1

4. Vorrichtung nach Anspruch 3, wobei die additive Spannung ein Gleichtaktsignal ist.
5. Vorrichtung nach einem beliebigen der Ansprüche 1 bis 4, wobei das Verarbeitungssystem dazu dient, die modifizierten Spannungsansteuersignale zu bestimmen, um das Ungleichgewicht zu verringern.
- 5 6. Vorrichtung nach Anspruch 5, wobei das Verarbeitungssystem ferner dazu eingerichtet ist, die Spannungsansteuersignale durch Modifizieren einer Phase und/oder eines Betrag wenigstens eines Spannungsansteuersignals zu modifizieren, das auf mindestens eine der Ansteuerelektroden angewendet ist.
- 10 7. Vorrichtung nach einem beliebigen der Ansprüche 1 bis 6, wobei das Verarbeitungssystem ferner für Folgendes ausgelegt ist:
- a) Veranlassen, dass das Spannungsansteuersignal über Ansteuerelektroden angewendet wird, die mit einer oberen ersten und einer unteren zweiten Extremität der Person verbunden sind; und
- 15 b) Bestimmen einer Anzeige des zweiten Signals über Abfühlelektroden, die mit einer oberen dritten und einer unteren vierten Extremität der Person verbunden sind, wobei sich die dritte und vierte Extremität von der ersten und zweiten Extremität unterscheiden.
8. Vorrichtung nach einem beliebigen der Ansprüche 1 bis 7, wobei das Verarbeitungssystem ferner für Folgendes ausgelegt ist:
- 20 a) Auswählen von Spannungssignalen, die an ausgewählten der Abfühlelektroden gemessen sind; und
b) Bestimmen eines eventuellen Ungleichgewichts mittels der ausgewählten Spannungssignale.
- 25 9. Vorrichtung nach einem beliebigen der Ansprüche 1 bis 8, wobei das Verarbeitungssystem ferner für Folgendes ausgelegt ist:
- a) Vergleichen der gemessenen Stromsignale mit einem Schwellwert; und
b) selektives Anhalten des Impedanzmessvorgangs in Abhängigkeit von den Ergebnissen des Vergleichs.
- 30 10. Vorrichtung nach einem beliebigen der Ansprüche 1 bis 9, wobei das Verarbeitungssystem ferner für Folgendes ausgelegt ist:
- a) Veranlassen eines Anwendens von Spannungsansteuersignalen auf die Person bei einer ersten Frequenz;
- 35 b) Bestimmen einer Anzeige eines zweiten Signals, das quer über die Person hinweg gemessen ist;
- c) Verwenden der Anzeige des zweiten Signals, um ein eventuelles Ungleichgewicht zu bestimmen;
- d) falls kein unannehmbares Ungleichgewicht vorliegt, Verwenden wenigstens der Anzeige des zweiten Signals, um wenigstens einen Impedanzwert zu bestimmen;
- 40 e) falls ein unannehmbares Ungleichgewicht vorliegt:
- i) Bestimmen modifizierter Spannungsansteuersignale in Übereinstimmung mit dem Ungleichgewicht;
- ii) Veranlassen eines Anwendens modifizierter Spannungsansteuersignale auf die Person;
- iii) Bestimmen einer weiteren Anzeige eines modifizierten zweiten Signals, das über die Person hinweg gemessen ist; und
- 45 iv) Wiederholen der Schritte c) bis e) für die Anzeige des modifizierten zweiten Signals;
- f) Wiederholen der Schritte a) bis e) für wenigstens eine zweite Frequenz.
11. Vorrichtung nach einem beliebigen der Ansprüche 1 bis 10, wobei die Spannungsansteuersignale erste und zweite Spannungsansteuersignale umfassen, die über entsprechende erste und zweite Ansteuerelektroden auf die Person angewendet sind, wobei das erste Spannungsansteuersignal einen ersten Betrag und eine erste Phase aufweist, und das zweite Spannungsansteuersignal einen zweiten Betrag und eine zweite Phase aufweist, und wobei das Verarbeitungssystem ferner dazu eingerichtet ist, die modifizierten Spannungsansteuersignale zu bestimmen, indem wenigstens eines von Folgendem modifiziert wird:
- 50 a) die erste Phase;
- b) der erste Betrag;
- 55 c) die zweite Phase; und

d) der zweite Betrag.

12. Vorrichtung nach einem beliebigen der Ansprüche 1 bis 11, wobei das Verarbeitungssystem ferner für Folgendes ausgelegt ist:

5

- a) Veranlassen eines Anwendens modifizierter Spannungsansteuersignale auf die Person;
- b) Bestimmen gemessener Spannungen, die über entsprechende Abfühlelektroden gemessen sind;
- c) Bestimmen, ob ein unannehmbares Ungleichgewicht vorliegt, unter Verwendung der gemessenen Spannungen; und

10

d) falls ein unannehmbares Ungleichgewicht vorliegt:

- i) Bestimmen weiterer modifizierter Spannungsansteuersignale; und
- ii) Wiederholen der Schritte (a) bis (d) bis ein eventuelles Ungleichgewicht annehmbar ist.

15

13. Vorrichtung nach einem beliebigen der Ansprüche 1 bis 12, wobei das Verarbeitungssystem ferner dazu eingerichtet ist, bei mehreren Frequenzen nacheinander Impedanzmessungen durchzuführen.

14. Vorrichtung nach Anspruch 13, wobei das Verarbeitungssystem ferner für Folgendes ausgelegt ist:

20

a) für eine erste Frequenz:

- i) Bestimmen modifizierter Spannungsansteuersignale, die ein annehmbares Ungleichgewicht ergeben; und
- ii) Veranlassen einer Durchführung einer Impedanzmessung unter Verwendung der modifizierten Spannungsansteuersignale;

25

und

b) für eine zweite Frequenz:

- i) Veranlassen eines Anwendens von Spannungsansteuersignalen auf die Person, wobei die Spannungsansteuersignale auf den modifizierten Spannungsansteuersignalen begründet sind, die für die erste Frequenz bestimmt sind; und
- ii) Bestimmen, ob ein unannehmbares Ungleichgewicht vorliegt.

30

15. Vorrichtung nach Anspruch 14, wobei das Verarbeitungssystem ferner für Folgendes ausgelegt ist:

35

a) für eine erste Frequenz:

- i) Veranlassen eines Anwendens erster und zweiter Spannungsansteuersignale auf die Person über entsprechende Ansteuerelektroden;
- ii) Bestimmen modifizierter erster und zweiter Spannungsansteuersignale, die ein annehmbares Ungleichgewicht ergeben, wobei das erste Spannungsansteuersignal einen ersten Betrag und eine erste Phase aufweist, und das zweite Spannungsansteuersignal einen zweiten Betrag und eine zweite Phase aufweist; und

40

b) für eine zweite Frequenz:

- i) Veranlassen eines Anwendens erster und zweiter Spannungsansteuersignale auf die Person, wobei das erste Spannungsansteuersignal den ersten Betrag und die erste Phase aufweist, und das zweite Spannungsansteuersignal den zweiten Betrag und die zweite Phase aufweist; und
- ii) Bestimmen, ob ein unannehmbares Ungleichgewicht vorliegt.

50

16. Vorrichtung nach einem beliebigen der Ansprüche 1 bis 15, wobei das Verarbeitungssystem ferner für Folgendes ausgelegt ist:

55

- a) Erzeugen von Steuersignalen;
- b) Übertragen der Steuersignale zu wenigstens einem Signalgenerator, um dadurch das Anwenden der Spannungsansteuersignale auf die Person zu veranlassen;
- c) Aufnehmen einer Anzeige der Spannungsansteuersignale, die auf die Person angewendet sind, von dem

wenigstens einen Signalgenerator;

d) Aufnehmen einer Anzeige erfasster Signale, die quer über die Person hinweg gemessen sind, von wenigstens einem Sensor, der mit einer Abfühlelektrode verbunden ist; und

e) Durchführen wenigstens einer vorbereitenden Verarbeitung der Anzeigen, um dadurch ein Bestimmen von Impedanzwerten zu ermöglichen.

5

17. Vorrichtung nach einem beliebigen der Ansprüche 1 bis 16, wobei die Vorrichtung einen Differentialverstärker zur Verstärkung erfasster Signale enthält, die an jeder der zwei Abfühlelektroden gemessen sind.

10

18. Vorrichtung nach Anspruch 17, wobei der Differentialverstärker wenigstens eines von Folgendem erzeugt:

a) eine Spannungsdifferenz, die die Spannung kennzeichnet, die an den Abfühlelektroden gemessen ist; und

b) ein Gleichtaktsignal, das ein eventuelles Ungleichgewicht kennzeichnet.

15

19. Vorrichtung nach einem beliebigen der Ansprüche 1 bis 18, wobei die Vorrichtung des weiteren wenigstens eines von Folgendem aufweist

a) wenigstens einen Signalgenerator zum Anwenden des Spannungsansteuersignals auf die Person über eine erste Elektrode; und

20

b) wenigstens einen Sensor zum Messen des erfassten Signals über Abfühlelektroden.

20. Vorrichtung nach einem beliebigen der Ansprüche 1 bis 19, wobei die Vorrichtung eine Anzahl von Elektrodensystemen enthält, und wobei jedes Elektrodensystem aufweist:

25

a) einen Sensor;

b) einen Signalgenerator; und

c) wenigstens eines von Folgendem:

30

i) einen Kapazitätsaufhebungsschaltkreis zum Aufheben einer kapazitiven Kopplung zwischen Ansteuer- und Abfühlelektroden; und

ii) einen Eingangskapazitätsaufhebungsschaltkreis zum Aufheben einer effektiven Eingangskapazität an einem Sensoreingang.

21. Vorrichtung nach einem beliebigen der Ansprüche 1 bis 20, wobei die Vorrichtung des weiteren aufweist:

35

a) eine Anzahl von Elektrodensystemen, und wobei jedes Elektrodensystem einen Signalgenerator und einen Sensor enthält; und

b) eine Anzahl von Anschlussleitungen zum Verbinden der Messvorrichtung mit den Elektrodensystemen, wobei jede Anschlussleitung umfasst:

40

i) mindestens zwei Verbindungen zum Verbinden der Messvorrichtung mit dem Signalgenerator und der Messvorrichtung mit dem Sensor; und

ii) eine Abschirmung für jede der mindestens zwei Verbindungen, wobei die Abschirmungen elektrisch verbunden sind und mit einer Referenzspannung sowohl der Messvorrichtung als auch des Elektrodensystems verbunden sind.

45

22. Verfahren zur Durchführung von Impedanzmessungen an einer Person, wobei das Verfahren die Schritte umfasst:

50

- Bereitstellen entsprechender Paare Ansteuer- und Abfühlelektroden an oberen und unteren Extremitäten der Person; und

- Verwenden eines Verarbeitungssystems zum Ausführen folgender Schritte:

55

a) Veranlassen eines Anwendens von Spannungsansteuersignalen auf die Person über Ansteuerelektroden;

b) Messen von durch die Person verlaufenden Stromsignalen, die durch die Spannungsansteuersignale hervorgerufen sind, über Abfühlelektroden;

c) Bestimmen einer Anzeige eines zweiten Signals, das quer über die Person hinweg gemessen ist, wobei die Anzeige des zweiten Signals eine im Zentrum des Rumpfes der Person vorhandene Körpermittensspan-

EP 2 211 714 B1

nung ist, die von Spannungen abgeleitet ist, die über Abfühlelektroden gemessen sind;

d) Verwenden der Anzeige des zweiten Signals, um ein eventuelles Ungleichgewicht zu bestimmen; und

e) falls ein Ungleichgewicht vorliegt:

5 i) Bestimmen modifizierter Spannungsansteuersignale in Übereinstimmung mit dem Ungleichgewicht durch:

Bestimmen oberer und unterer Impedanzen für die Person unter Verwendung der gemessenen
10 Stromsignale, der Spannungsansteuersignale und der Körpermittenspannung; und
Bestimmen modifizierter Spannungsansteuersignale diese die oberen und unteren Impedanzen
und eine Soll-Stromsignal-Anzeige; und

15 ii) Veranlassen eines Anwendens modifizierter Spannungsansteuersignale auf die Person, um dadurch
eine Durchführung wenigstens einer Impedanzmessung zu ermöglichen.

Revendications

20 1. Dispositif à utiliser pour effectuer des mesures d'impédance sur un sujet, comprenant

- des paires respectives d'électrodes de pilotage et de détection devant être placées sur des membres supérieurs
et inférieurs du sujet ; et

- un système de traitement configuré pour :

25 a) provoquer l'application au sujet de signaux de pilotage de tension via les électrodes de pilotage ;
b) détecter, via des électrodes de détection, des signaux de courant traversant le sujet, engendrés par les
signaux de pilotage de tension ;

30 c) déterminer une indication d'un deuxième signal sur le sujet, ladite indication dudit deuxième signal étant
une tension du centre du corps au centre du torse du sujet dérivant de tensions détectées via les électrodes
de détection ;

d) utiliser l'indication du deuxième signal pour déterminer s'il existe un déséquilibre inacceptable ;
et

e) si un déséquilibre inacceptable existe :

35 i) déterminer des signaux de pilotage de tension modifiés conformément au déséquilibre déterminé en :

déterminant des impédances supérieure et inférieure pour le sujet en utilisant les signaux de
courant détectés, les signaux de pilotage de tension et la tension du centre du corps ; et

40 déterminant des signaux de pilotage de tension modifiés en utilisant lesdites impédances supé-
rieure et inférieure et une indication de signal de courant idéal ; et

ii) provoquer l'application au sujet des signaux de pilotage de tension modifiés de façon à permettre
ainsi la réalisation d'au moins une mesure d'impédance.

45 2. Dispositif selon la revendication 1, dans lequel le système de traitement est en outre configuré pour réaliser l'étape
d) en :

a) comparant l'indication d'un deuxième signal à un seuil ; et

b) déterminant s'il existe un déséquilibre inacceptable en fonction des résultats de la comparaison.

50 3. Dispositif selon la revendication 1 ou la revendication 2, dans lequel le système de traitement est en outre configuré
pour :

a) déterminer la tension détectée au niveau de chacune des électrodes de détection ;

55 b) déterminer une tension additive ; et

c) déterminer le déséquilibre en utilisant la tension additive.

4. Dispositif selon la revendication 3, dans lequel la tension additive est un signal de mode commun.

EP 2 211 714 B1

5. Dispositif selon l'une quelconque des revendications 1 à 4, dans lequel le système de traitement sert à déterminer les signaux de pilotage de tension modifiés de façon à réduire le déséquilibre.
- 5 6. Dispositif selon la revendication 5, dans lequel le système de traitement est en outre configuré pour modifier les signaux de pilotage de tension en modifiant au moins l'une parmi une phase et une amplitude d'au moins un signal de signal de pilotage de tension appliqué à au moins l'une des électrodes de pilotage.
- 10 7. Dispositif selon l'une quelconque des revendications 1 à 6, dans lequel le dispositif de traitement est en outre configuré pour :
- 15 a) provoquer l'application du signal de pilotage de tension via des électrodes de pilotage couplées à un premier membre supérieur et un deuxième membre inférieur du sujet ; et
b) déterminer une indication du deuxième signal via des électrodes de détection couplées à un troisième membre supérieur et un quatrième membre inférieur du sujet, les troisième et quatrième membres étant différents des premier et deuxième membres.
- 20 8. Dispositif selon l'une quelconque des revendications 1 à 7, dans lequel le système de traitement est en outre configuré pour :
- 25 a) sélectionner des signaux de tension détectés au niveau d'électrodes sélectionnées parmi les électrodes de détection ; et
b) déterminer un quelconque déséquilibre en utilisant les signaux de tension sélectionnés.
- 30 9. Dispositif selon l'une quelconque des revendications 1 à 8, dans lequel le système de traitement est en outre configuré pour :
- 35 a) comparer les signaux de courant détectés à un seuil ; et
b) stopper sélectivement le procédé de mesure d'impédance en fonction des résultats de la comparaison.
- 40 10. Dispositif selon l'une quelconque des revendications 1 à 9, dans lequel le système de traitement est en outre configuré pour :
- 45 a) provoquer l'application au sujet de signaux de pilotage de tension à une première fréquence ;
b) déterminer une indication d'un deuxième signal mesuré sur le sujet ;
35 c) utiliser l'indication du deuxième signal pour déterminer un quelconque déséquilibre ;
d) s'il n'existe pas de déséquilibre inacceptable, utiliser au moins l'indication du deuxième signal pour déterminer au moins une valeur d'impédance ;
e) s'il existe un déséquilibre inacceptable :
- 40 i) déterminer des signaux de pilotage de tension modifiés en fonction du déséquilibre ;
ii) provoquer l'application au sujet des signaux de pilotage de tension modifiés ;
iii) déterminer une autre indication d'un deuxième signal modifié sur le sujet ; et
iv) répéter les étapes c) à e) pour l'indication du deuxième signal modifié ;
- 45 f) répéter les étapes a) à e) pour au moins une deuxième fréquence.
- 50 11. Dispositif selon l'une quelconque des revendications 1 à 10, dans lequel les signaux de pilotage de tension comprennent des premier et deuxième signaux de pilotage de tension appliqués au sujet via des première et deuxième électrodes de pilotage respectives, le premier signal de pilotage de tension ayant une première amplitude et une première phase, et le deuxième signal de pilotage de tension ayant une deuxième amplitude et une deuxième phase, et dans lequel le système de traitement est en outre configuré pour déterminer les signaux de pilotage de tension modifiés en modifiant au moins l'une parmi :
- 55 a) la première phase ;
b) la première amplitude ;
c) la deuxième phase ; et
d) la deuxième amplitude.

EP 2 211 714 B1

12. Dispositif selon l'une quelconque des revendications 1 à 11, dans lequel le système de traitement est en outre configuré pour :

- a) provoquer l'application au sujet des signaux de pilotage de tension modifiés ;
- b) déterminer des tensions détectées mesurées via des électrodes de détection respectives ;
- c) déterminer s'il existe un déséquilibre inacceptable en utilisant les tensions détectées ; et
- d) s'il existe un déséquilibre inacceptable :

- i) déterminer d'autres signaux de pilotage de tension modifiés ; et
- ii) répéter les étapes (a) à (d) jusqu'à ce que tout déséquilibre soit acceptable.

13. Dispositif selon l'une quelconque des revendications 1 à 12, dans lequel le système de traitement est en outre configuré pour effectuer des mesures d'impédance à de multiples fréquences, tour à tour.

14. Dispositif selon la revendication 13, dans lequel le système de traitement est en outre configuré pour :

a) pour une première fréquence

- i) déterminer des signaux de pilotage de tension modifiés ayant pour résultat un déséquilibre inacceptable ; et
- ii) provoquer la réalisation d'une mesure d'impédance utilisant les signaux de pilotage de tension modifiés ; et

b) pour une deuxième fréquence

- i) provoquer l'application au sujet de signaux de pilotage de tension, lesdits signaux de pilotage de tension étant basés sur les signaux de pilotage de tension modifiés déterminés pour la première fréquence ; et
- ii) déterminer s'il existe un déséquilibre inacceptable.

15. Dispositif selon la revendication 14, dans lequel le système de traitement est en outre configuré pour :

a) pour une première fréquence

- i) provoquer l'application au sujet de premier et deuxième signaux de pilotage de tension via des électrodes de pilotage respectives ;
- ii) déterminer des premier et deuxième signaux de pilotage de tension modifiés ayant pour résultat un déséquilibre inacceptable, le premier signal de pilotage de tension ayant une première amplitude et une première phase, et le deuxième signal de pilotage de tension ayant une deuxième amplitude et une deuxième phase ; et

b) pour une deuxième fréquence

- i) provoquer l'application au sujet de premier et deuxième signaux de pilotage de tension, le premier signal de pilotage de tension ayant la première amplitude et la première phase, et le deuxième signal de pilotage de tension ayant la deuxième amplitude et la deuxième phase ; et
- ii) déterminer s'il existe un déséquilibre inacceptable.

16. Dispositif selon l'une quelconque des revendications 1 à 15, dans lequel le système de traitement est en outre configuré pour :

- a) générer des signaux de commande ;
- b) transférer les signaux de commande à au moins un générateur de signal, ce qui provoque ainsi l'application au sujet des signaux de pilotage de tension ;
- c) recevoir une indication des signaux de pilotage de tension appliqués au sujet depuis l'au moins un générateur de signal ;
- d) recevoir une indication de signaux détectés mesurés sur le sujet depuis au moins un capteur connecté à une électrode de détection ; et
- e) effectuer au moins un traitement préliminaire des indications de façon à permettre ainsi la détermination de

EP 2 211 714 B1

valeurs d'impédance.

5 17. Dispositif selon l'une quelconque des revendications 1 à 16, lequel dispositif comprend un amplificateur différentiel pour amplifier des signaux détectés mesurés au niveau de chacune de deux électrodes de détection.

18. Dispositif selon la revendication 17, dans lequel l'amplificateur différentiel génère au moins l'un parmi :

- 10 a) une tension différentielle indicative de la tension mesurée au niveau des électrodes de détection ; et
b) un signal de mode commun indicatif d'un quelconque déséquilibre.

19. Dispositif selon l'une quelconque des revendications 1 à 18, lequel dispositif comprend au moins l'un parmi :

- 15 a) au moins un générateur de signal pour appliquer le signal de pilotage de tension au sujet via une première électrode ; et
b) au moins un capteur pour mesurer le signal détecté via des électrodes de détection.

20. Dispositif selon l'une quelconque des revendications 1 à 19, lequel dispositif comprend un certain nombre de systèmes d'électrodes, et dans lequel chaque système d'électrode comprend :

- 20 a) un capteur ;
b) un générateur de signal ; et
c) au moins l'un parmi :

- 25 i) un circuit d'annulation capacitive pour annuler un couplage capacitif entre des électrodes de pilotage et de détection ; et
ii) un circuit d'annulation de capacité d'entrée pour annuler une capacité d'entrée efficace au niveau d'une entrée de capteur.

30 21. Dispositif selon l'une quelconque des revendications 1 à 20, lequel dispositif comprend en outre :

- 35 a) un certain nombre de systèmes d'électrodes, chaque système d'électrode comprenant un générateur de signal et un capteur ; et
b) un certain nombre de conducteurs pour connecter le dispositif de mesure aux dispositifs d'électrodes, chaque conducteur comprenant :

- 40 i) au moins deux connexions pour connecter le dispositif de mesure et le générateur de signal, et le dispositif de mesure et le capteur ; et
ii) un blindage pour chacune des au moins deux connexions, les blindages étant connectés électriquement et étant connectés à une tension de référence dans chacun parmi le dispositif de mesure et le système d'électrode.

22. Procédé à utiliser dans la réalisation de mesures d'impédance sur un sujet, lequel procédé comprend les opérations consistant à :

- 45 - disposer de paires respectives d'électrodes de pilotage et de détection sur des membres supérieurs et inférieurs du sujet ; et
- employer un système de traitement pour réaliser les étapes consistant à :

- 50 a) provoquer l'application au sujet de signaux de pilotage de tension via des électrodes de pilotage ;
b) détecter, via des électrodes de détection, des signaux de courant traversant le sujet, engendrés par les signaux de pilotage de tension ;
c) déterminer une indication d'un deuxième signal mesuré sur le sujet, l'indication du deuxième signal étant une tension du centre du corps au centre du torse du sujet dérivant des tensions détectées via les électrodes de détection ;
55 d) utiliser l'indication du deuxième signal pour déterminer s'il existe un quelconque déséquilibre ; et
e) s'il existe un déséquilibre :

- i) déterminer des signaux de tension de pilotage de tension modifiés en fonction du déséquilibre en :

EP 2 211 714 B1

déterminant des impédances supérieure et inférieure pour le sujet en utilisant les signaux de courant détectés, les tensions de pilotage de tension et la tension du centre du corps ; et déterminant des signaux de pilotage de tension modifiés lesdites les impédances supérieure et inférieure et une indication de signal de courant idéal ; et

5

ii) provoquer l'application au sujet des signaux de pilotage de tension modifiés de façon à permettre ainsi la réalisation d'au moins une mesure d'impédance.

10

15

20

25

30

35

40

45

50

55

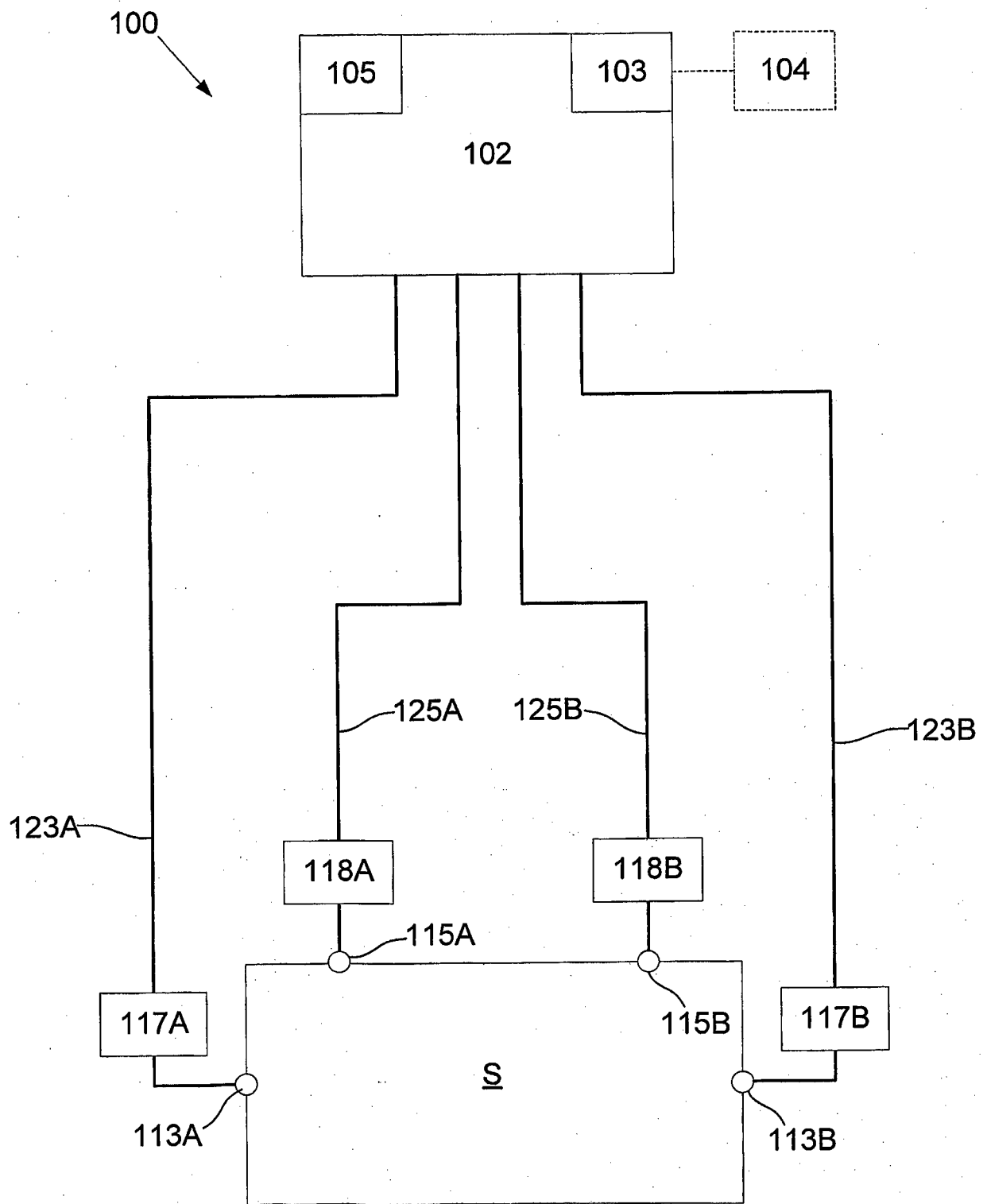

Fig. 1

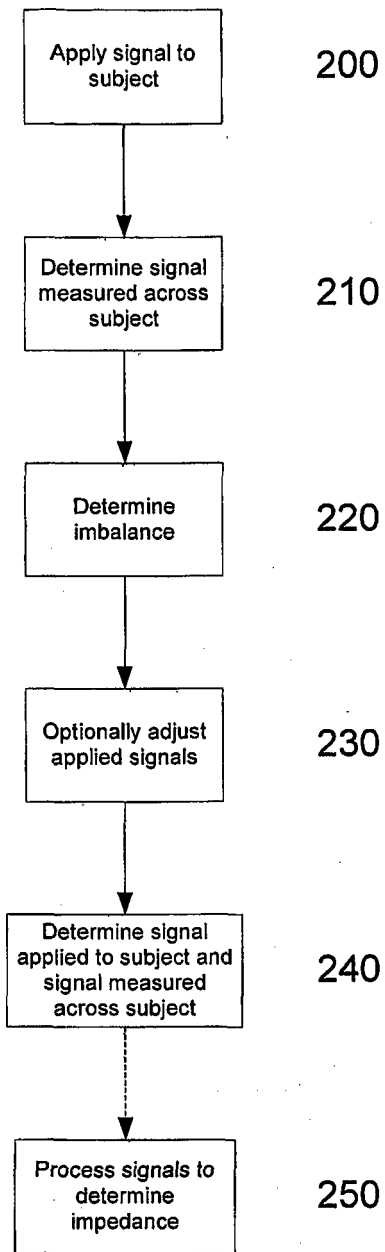

Fig. 2

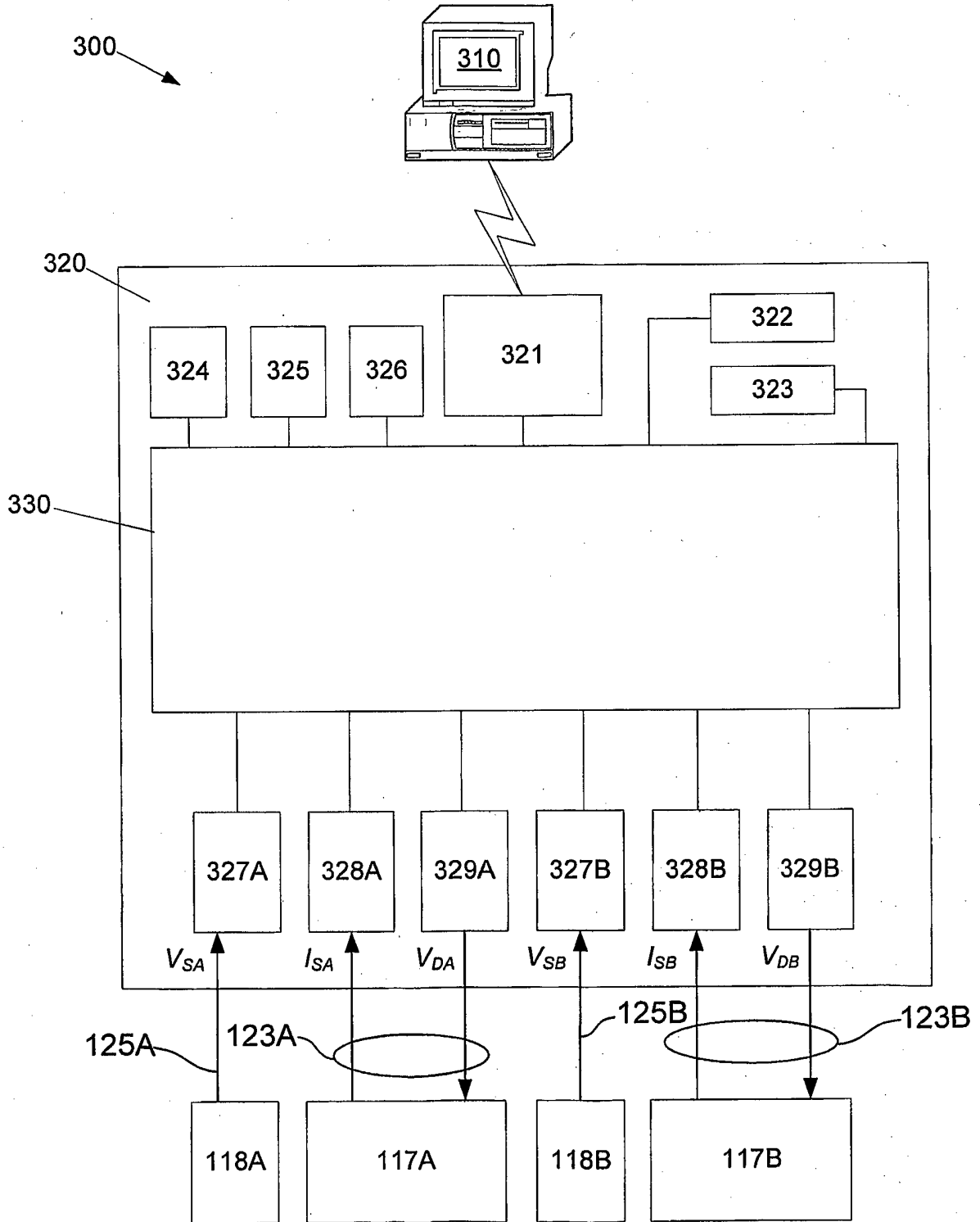

Fig. 3

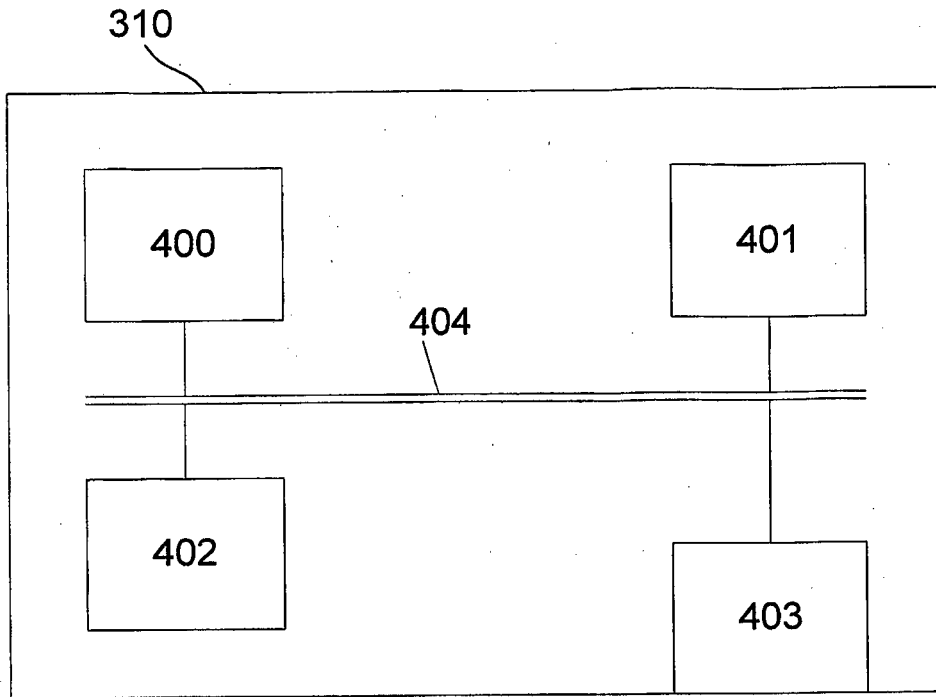

Fig. 4

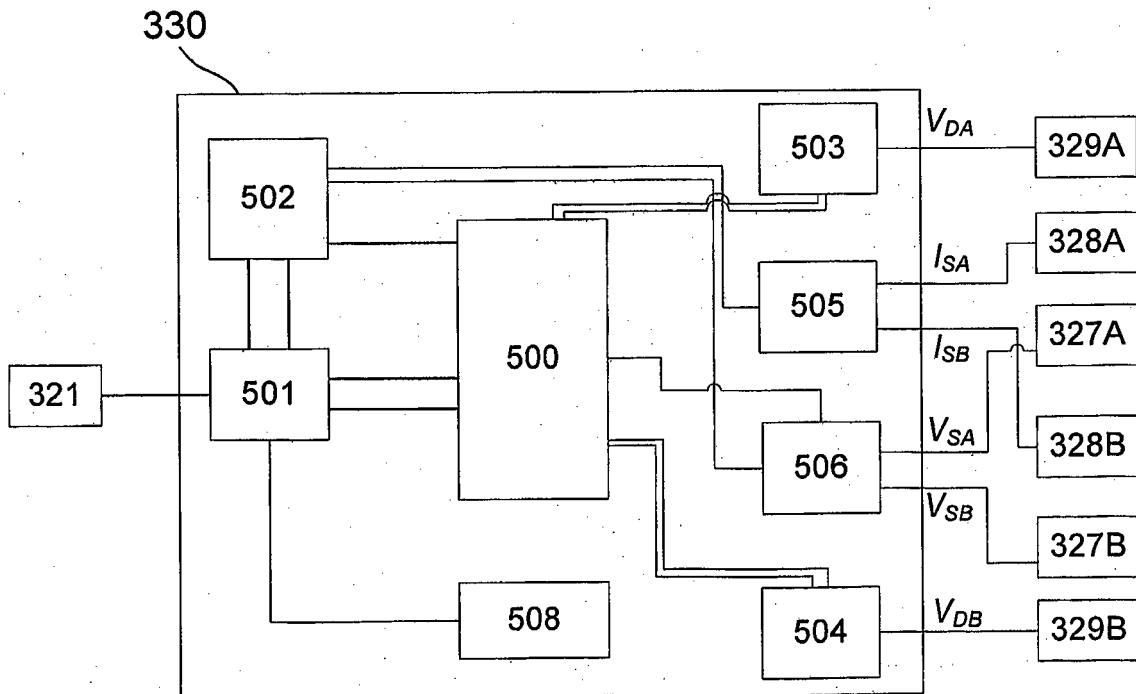

Fig. 5

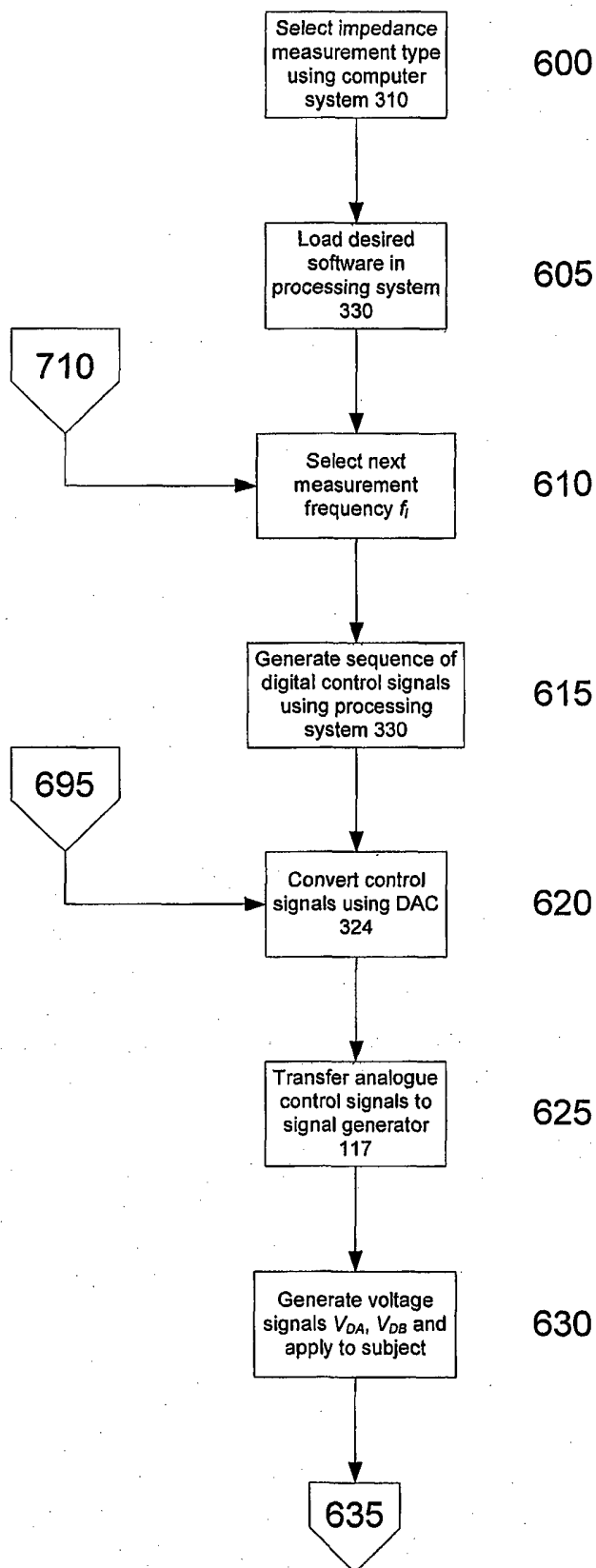

Fig. 6A

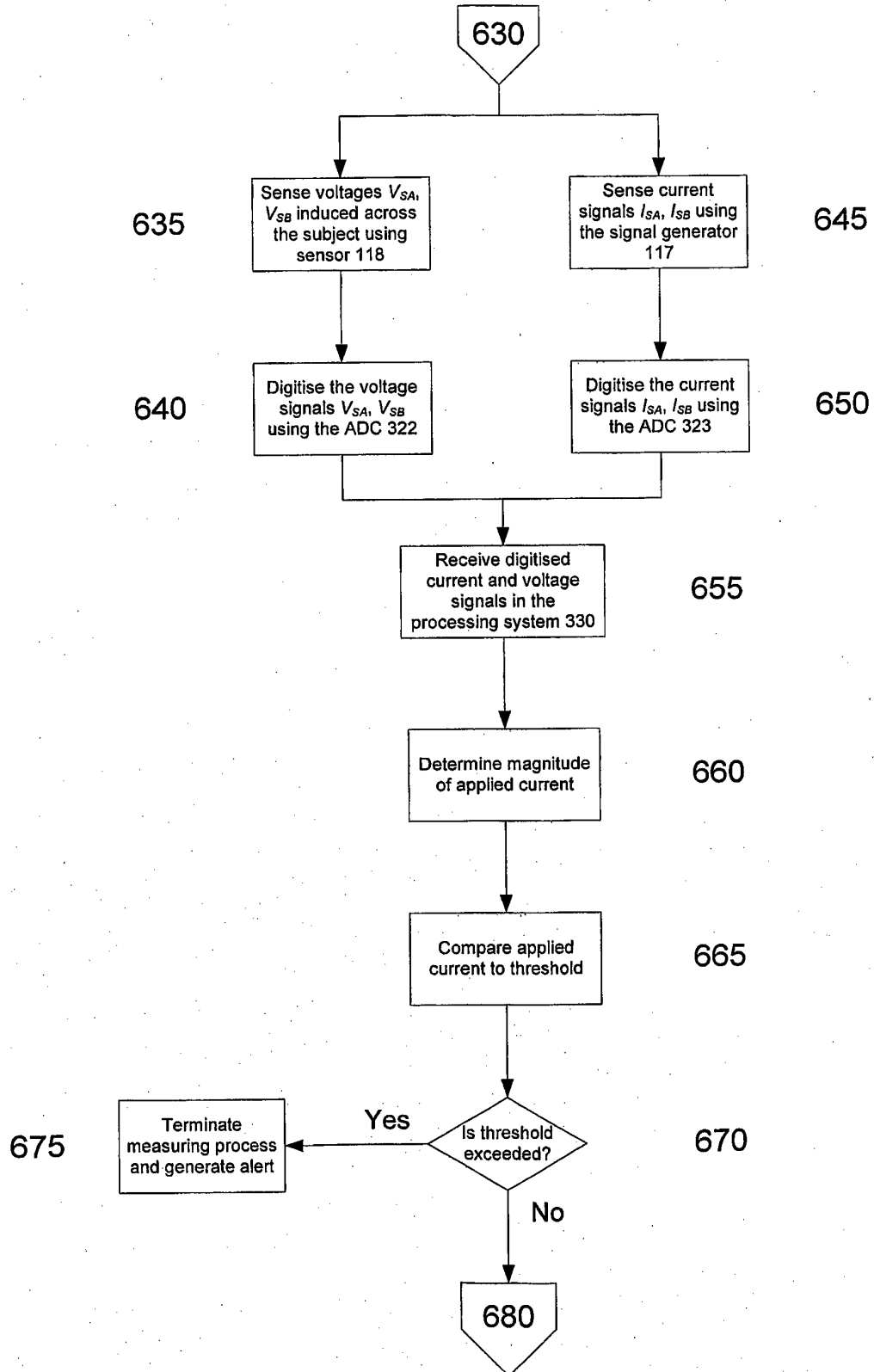

Fig.6B

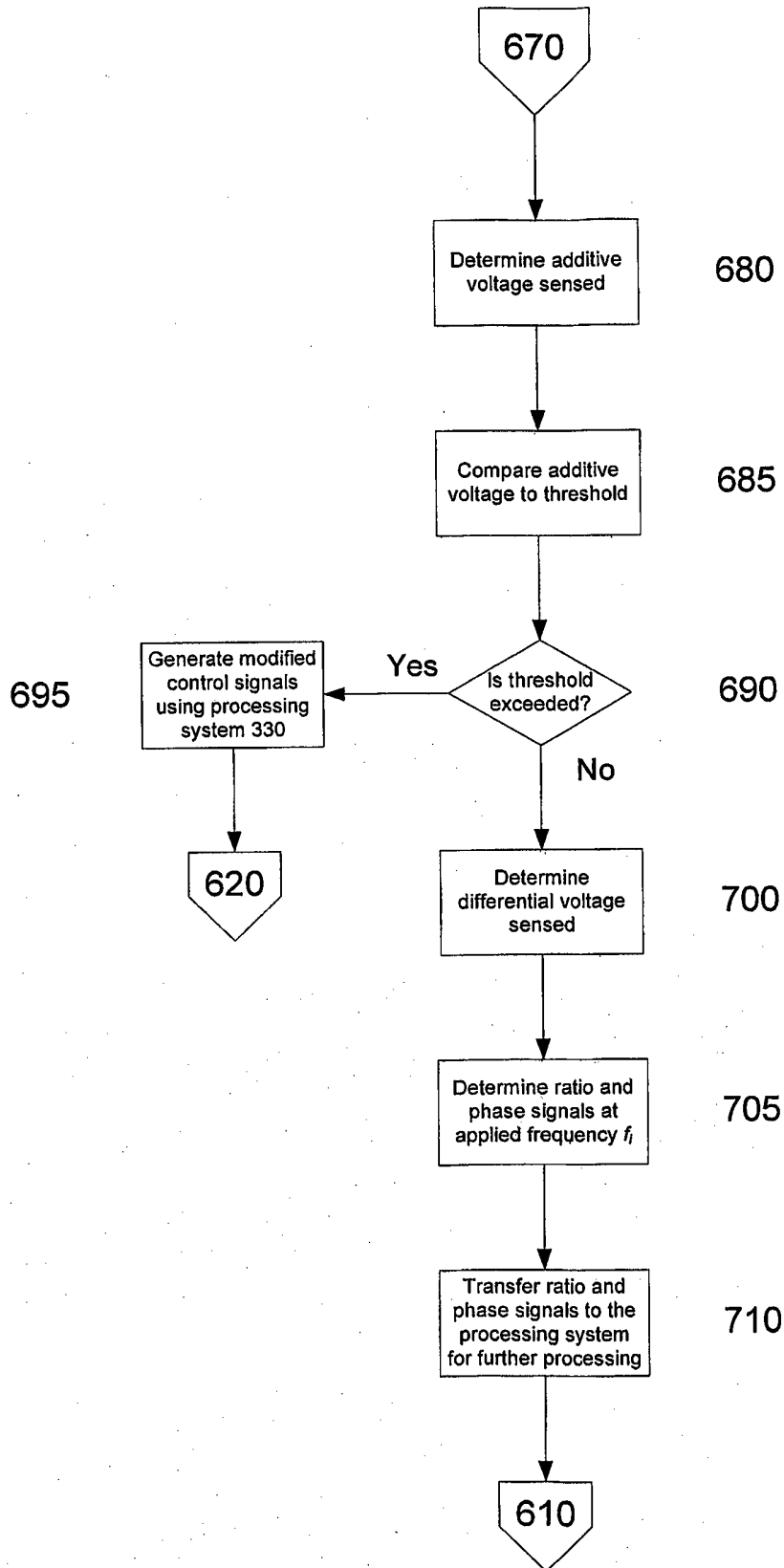

Fig.6C

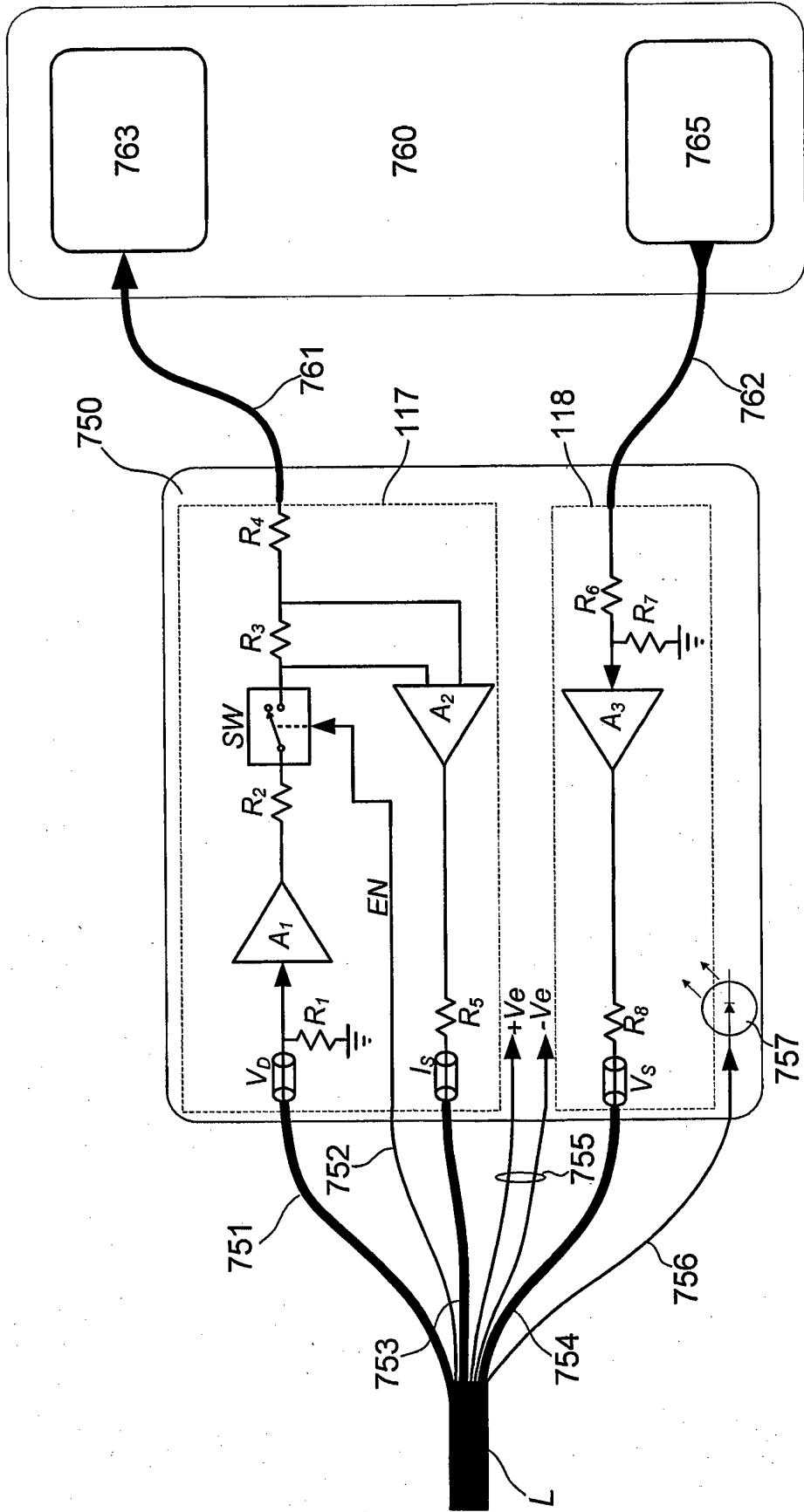

Fig. 7A

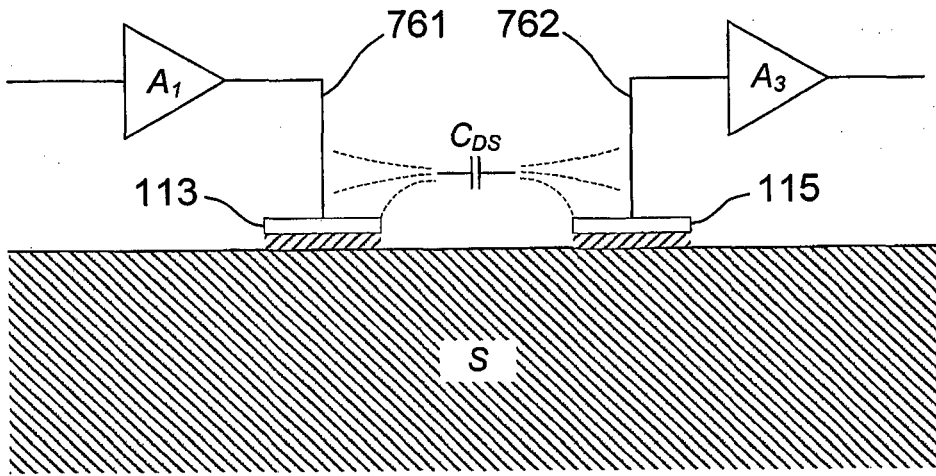

Fig. 7B

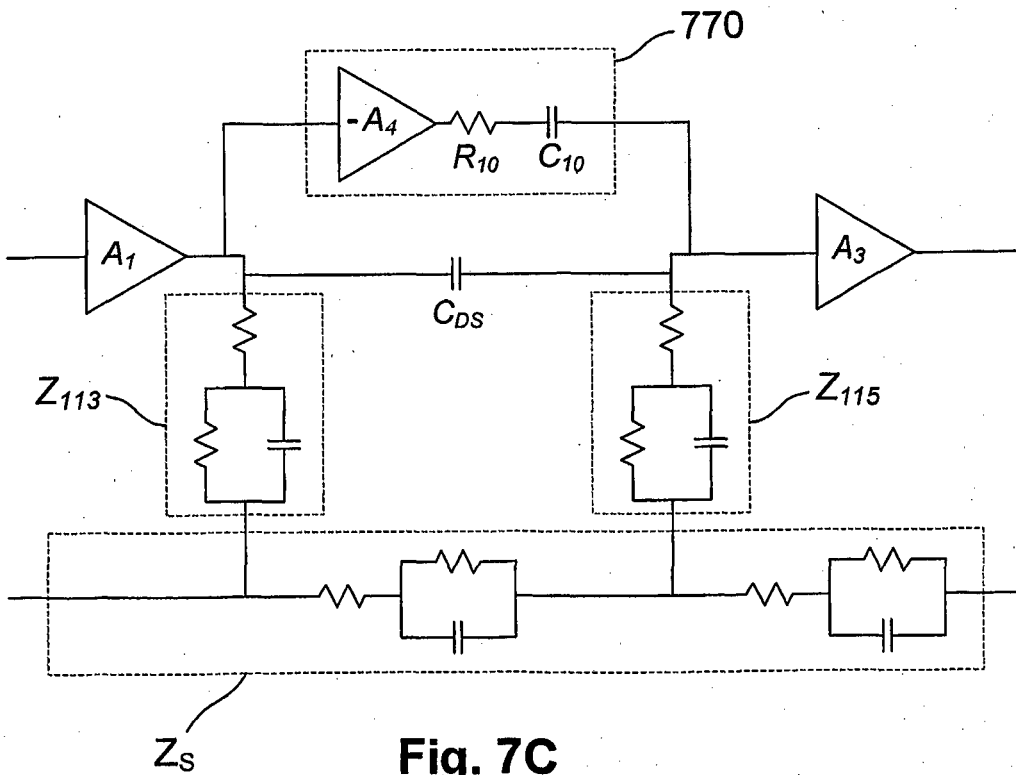

Fig. 7C

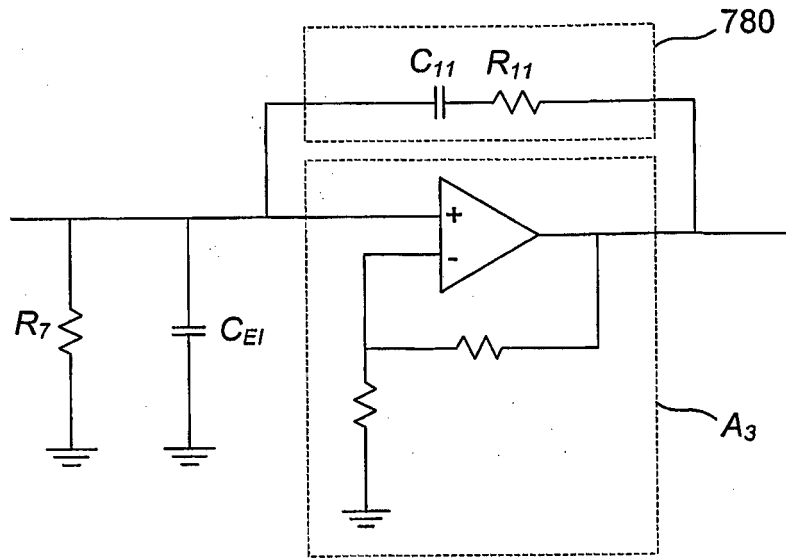

Fig. 7D

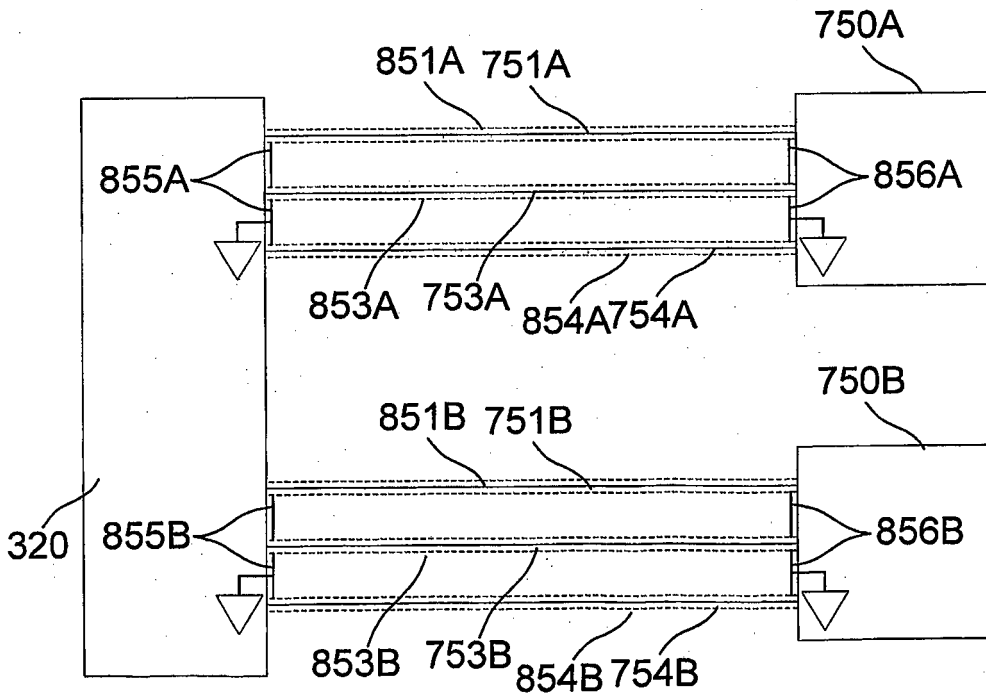

Fig. 8

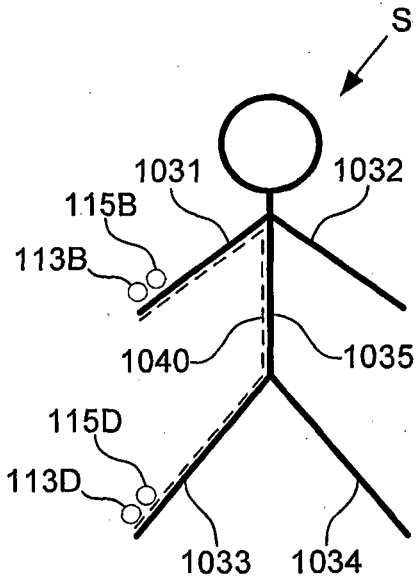

Fig. 10A

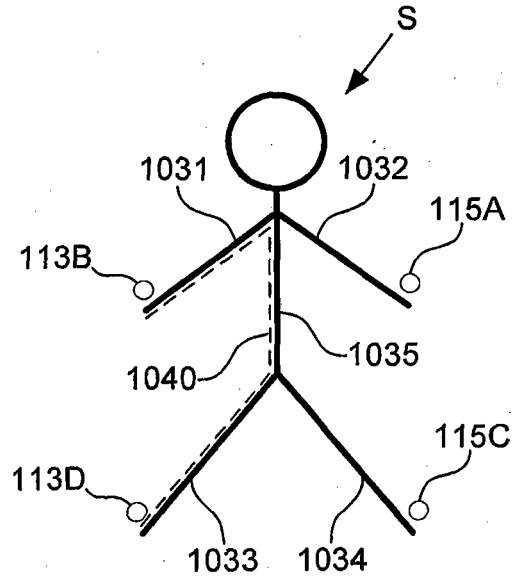

Fig. 10B

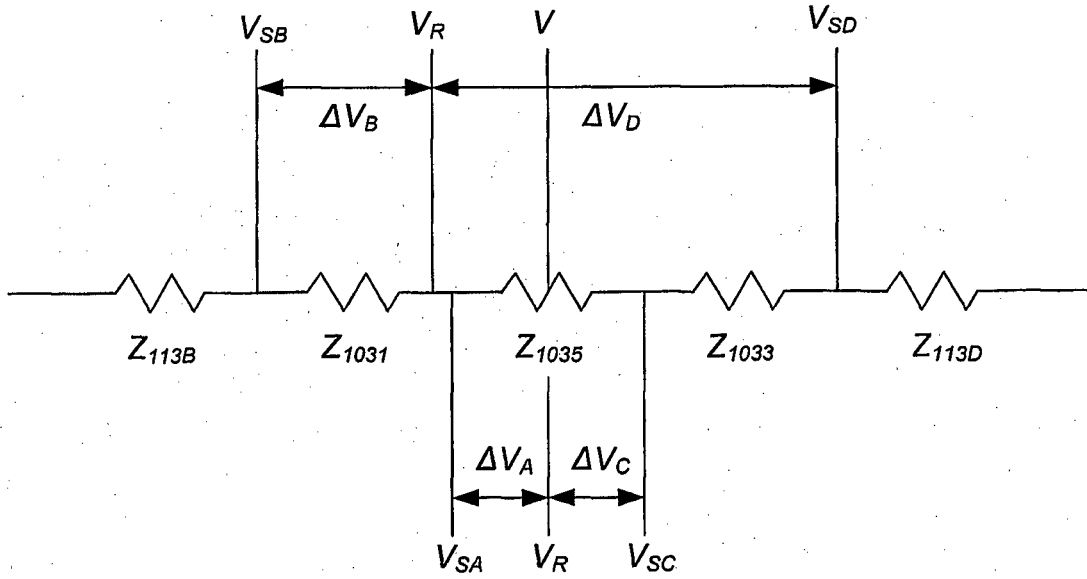

Fig. 10C

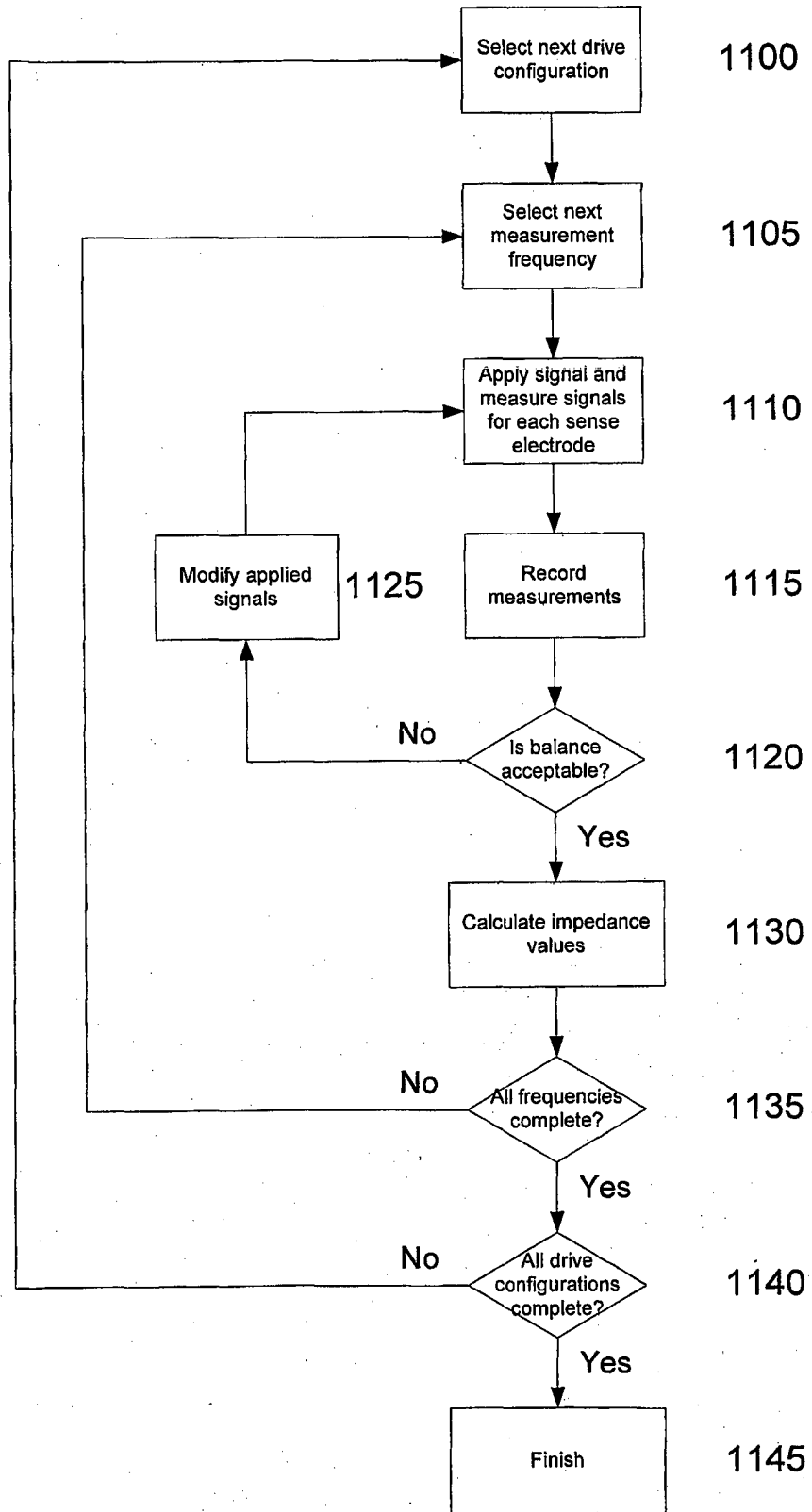

Fig. 11

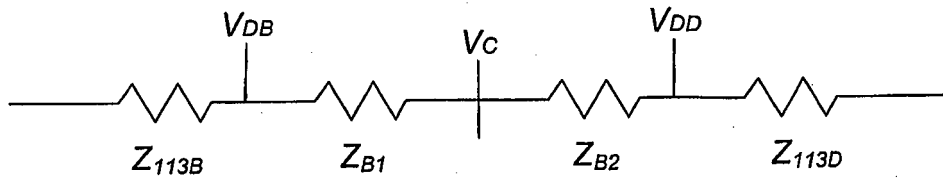

Fig. 12A

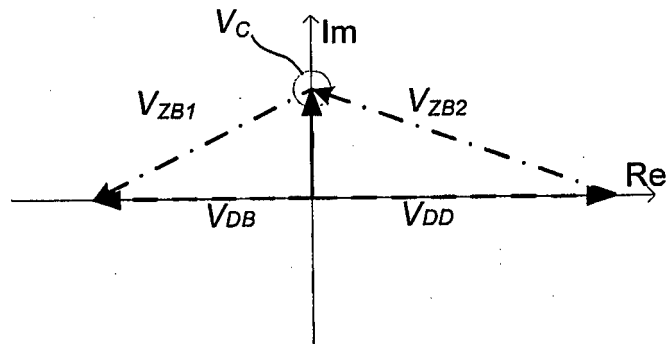

Fig. 12B

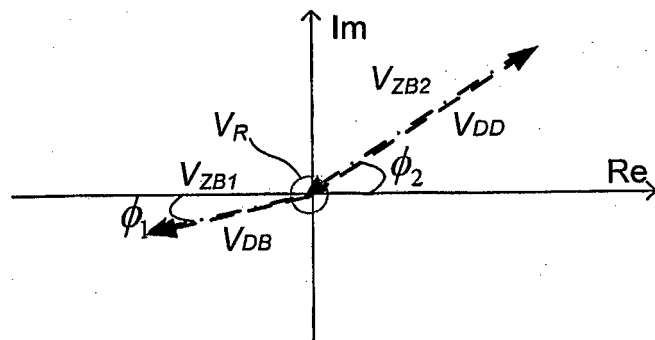

Fig. 12C

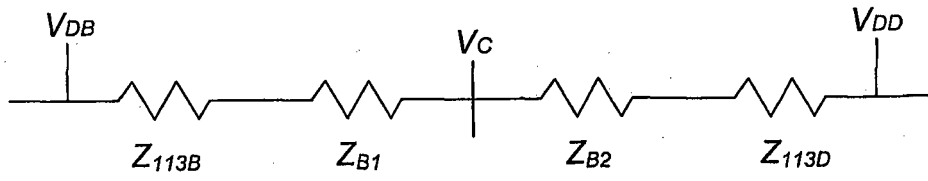

Fig. 12D

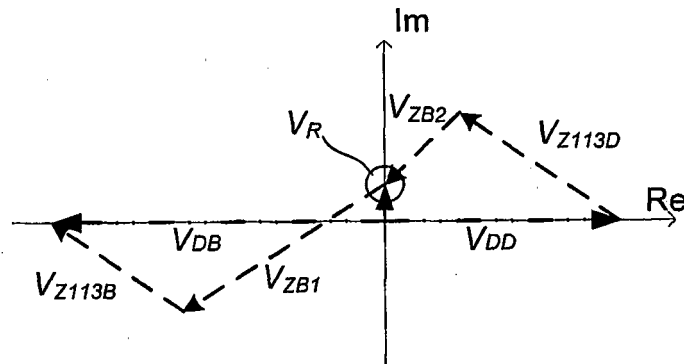

Fig. 12E

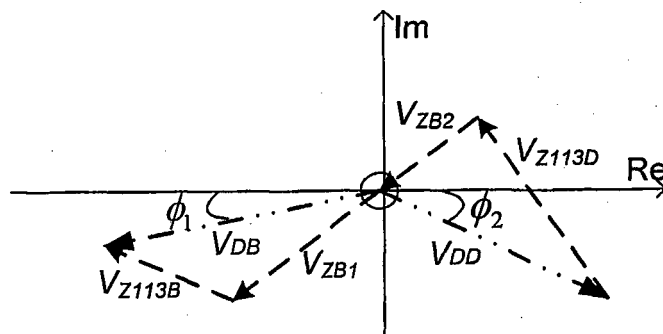

Fig. 12F

REFERENCES CITED IN THE DESCRIPTION

This list of references cited by the applicant is for the reader's convenience only. It does not form part of the European patent document. Even though great care has been taken in compiling the references, errors or omissions cannot be excluded and the EPO disclaims all liability in this regard.

Patent documents cited in the description

- US 2005151545 A [0005]
- US 2007010758 A [0006]
- US 6236886 B [0007]
- US 6631292 B [0008]
- US 6339722 B [0009]

专利名称(译)	阻抗确定		
公开(公告)号	EP2211714A4	公开(公告)日	2015-04-01
申请号	EP2008800155	申请日	2008-10-15
申请(专利权)人(译)	IMPEDIMED有限公司		
当前申请(专利权)人(译)	IMPEDIMED有限公司		
[标]发明人	CHETHAM SCOTT DALY CHRISTOPHER NEWTON BRUINSMA IAN JOHN		
发明人	CHETHAM, SCOTT DALY, CHRISTOPHER NEWTON BRUINSMA, IAN JOHN		
IPC分类号	A61B5/053 A61B5/00		
CPC分类号	A61B5/053 A61B5/6885 A61B5/7203 G01R1/06 G01R1/18 G01R1/30 G01R27/02		
优先权	2007906049 2007-11-05 AU		
其他公开文献	EP2211714B1 EP2211714A1		
外部链接	Espacenet		

摘要(译)

用于对受试者进行阻抗测量的装置。该装置包括处理系统，用于使第一信号施加到受试者，确定在受试者上测量的第二信号的指示，使用第二信号的指示来确定任何不平衡并且如果存在不平衡，则确定修改的第一信号根据不平衡并使修改的第一信号施加到对象，从而允许执行至少一个阻抗测量。