

(19)



(11)

EP 1 641 384 B1

(12)

EUROPEAN PATENT SPECIFICATION

(45) Date of publication and mention of the grant of the patent:
31.10.2012 Bulletin 2012/44

(51) Int Cl.:
A61B 3/12 (2006.01)

(21) Application number: **04737431.9**

(86) International application number:
PCT/AU2004/000801

(22) Date of filing: **18.06.2004**

(87) International publication number:
WO 2004/112599 (29.12.2004 Gazette 2004/53)

(54) OPHTHALMIC CAMERA, OPHTHALMIC CAMERA ADAPTOR AND METHODS FOR DETERMINING A HAEMOGLOBIN AND GLUCOSE LEVEL OF A PATIENT

OPHTHALMISCHE KAMERA, OPHTHALMISCHER KAMERAADAPTER UND VERFAHREN ZUR BESTIMMUNG DES HÄMOGLOBIN- UND GLUCOSE-SPIEGELS EINES PATIENTEN

CAMERA OPHTHALMIQUE, ADAPTATEUR DE CAMERA OPHTHALMIQUE ET PROCÉDES DE DETERMINATION DU TAUX D'HEMOGLOBINE ET DE GLUCOSE D'UN PATIENT

(84) Designated Contracting States:
AT BE BG CH CY CZ DE DK EE ES FI FR GB GR HU IE IT LI LU MC NL PL PT RO SE SI SK TR

• **CONSTABLE, Ian**
Nedlands, Western Australia 6009 (AU)

(30) Priority: **20.06.2003 AU 2003903157**

(74) Representative: **Neath, Susannah Mairi**
Dehns
St Bride's House
10 Salisbury Square
London
EC4Y 8JD (GB)

(43) Date of publication of application:
05.04.2006 Bulletin 2006/14

(73) Proprietor: **Lions Eye Institute Limited**
Nedlands, W.A. 6009 (AU)

(56) References cited:
WO-A-97/37584 **WO-A1-00/06017**
WO-A2-03/012486 **JP-A- 9 266 888**
JP-A- 10 118 030 **JP-A- 11 299 735**
JP-A- 2002 051 985 **US-A- 5 285 223**
US-A1- 2003 011 757 **US-A1- 2003 050 544**
US-B1- 6 305 804

(72) Inventors:
• **YOGESAN, Kanagasingam**
Nedlands, Western Australia 6009 (AU)
• **SUPLEWSKI, Gabriel**
Western Australia, 6028 (AU)
• **SPARK, Matthew, David**
High Wycombe, Western Australia 6057 (AU)

EP 1 641 384 B1

Note: Within nine months of the publication of the mention of the grant of the European patent in the European Patent Bulletin, any person may give notice to the European Patent Office of opposition to that patent, in accordance with the Implementing Regulations. Notice of opposition shall not be deemed to have been filed until the opposition fee has been paid. (Art. 99(1) European Patent Convention).

Description**Field of the Invention**

[0001] The present invention relates to an ophthalmic camera, ophthalmic camera adaptor and methods, for determining a haemoglobin and glucose level of a patient. In particular, the invention relates to a miniaturised ophthalmic camera adaptor for non-mydratic use.

Background Art

[0002] The following discussion of the background to the invention is intended to facilitate an understanding of the present invention. However, it should be appreciated that the discussion is not an acknowledgement or admission that any of the material referred to was published, known or part of the common general knowledge of a skilled person in any jurisdiction as at the priority date of the application.

[0003] The eye is a complex structure having multiple layers and sub-structures. In order to obtain a diagnosis of certain adverse conditions of the eye, images of one or more layers or sub-structures need to be captured.

[0004] Previously, such images were obtained by the use of a monochromatic camera having narrow wavelength coloured paper filters covering an associated light source. However, this arrangement produces deficiencies, namely:

- Light passing through a paper filter typically has a variable wavelength reflecting the variations in the surface of the paper filter;
- The associated light source is typically brighter than is needed to illuminate the eye; and
- As different layers of sub-structures of the eye need to be imaged, time needs to be spent in changing the paper filter.

[0005] It is therefore an object of the present invention to provide an optical arrangement that alleviates some or all of the problems associated with the prior art. An apparatus according to the preamble of claim 1 is known from US 2003/0011757.

Disclosure of the Invention

[0006] Throughout the specification, unless the context requires otherwise, the word "comprise" or variations such as "comprises" or "comprising", will be understood to imply the inclusion of a stated integer or group of integers but not the exclusion of any other integer or group of integers.

[0007] In accordance with a first embodiment of the invention there is an ophthalmic camera comprising:

a camera having a camera lens;

at least one illumination means; and

an ophthalmic lens,

where, the centres of the ophthalmic lens and camera lens are aligned to form an alignment axis and where the at least one illumination means is capable of linear movement along a radial axis of the camera lens and pivotal movement about the radial plane incorporating radial axis and alignment axis, such that the circle of light emitted by the at least one illumination means is constantly directed to the centre of the ophthalmic lens.

[0008] Preferably, the ophthalmic camera further comprises selection means for choosing from a plurality of settings, each setting representing a pupil size or range of pupil sizes, such that, when the setting is changed, the at least one illumination means moves linearly along its radial axis to the position specified by the new setting and pivots about the radial plane until the circle of light emitted by the at least one illumination means is directed on the centre of the ophthalmic lens.

[0009] Alternatively, the linear and pivotal movement of the at least one illumination means is controlled by one or more manual control.

[0010] As yet a further alternative, the ophthalmic camera comprises automated measuring means for obtaining a measurement of the size of the pupil to be examined, the automated measuring means also controlling the linear and pivotal movement of the at least one illumination means to a position determined best for the measured pupil size.

[0011] Preferably, the ophthalmic camera comprises at least one magnification lens, each magnification lens being associated with at least one linear position of the at least one illumination means, such that the linear position of the at least one illumination means determines which magnification lens are positioned within the alignment axis.

[0012] Preferably, one of the at least one illumination means has a wavelength in the range 450 to 490nm. Ideally, the illumination means has a wavelength of 490nm.

[0013] Preferably, one of the at least one illumination means has a wavelength in the range 491 to 559nm: Ideally, the illumination means has a wavelength of 540nm.

[0014] Preferably, one of the at least one illumination means has a wavelength in the range 560 to 595nm. Ideally, the illumination means has a wavelength of 590nm.

[0015] Preferably, one of the at least one illumination means has a wavelength in the range 596 to 699nm. Ideally, the illumination means has a wavelength of 630nm.

[0016] Preferably, one of the at least one illumination means has a wavelength of 700nm,

[0017] Preferably, one of the at least one illumination means produces white light.

[0018] Preferably, the camera is a digital camera or an analogue camera with digitising means for producing a digital representation of analogue images taken by the analogue camera.

[0019] Preferably, the at least one illumination means, or a subset of the at least one illumination means, is illuminated in accordance with a predetermined sequence.

[0020] Preferably, the ophthalmic camera has at least one interface means for connecting to at least one of the following: an external computer, an external monitor, an external spectrometer.

[0021] Preferably, the ophthalmic camera comprises a spectrometer, the spectrometer operable to produce a spectroscopic graph of images taken by the camera.

[0022] Preferably, the at least one illumination means is of variable intensity. Ideally, the level of intensity of the at least one illumination means is a function of a pupil colour setting of the ophthalmic camera.

[0023] Preferably, each of the at least one illumination means surrounds the circumference of the camera lens.

[0024] Preferably, each illumination means is equidistant from its adjacent illumination means.

[0025] Preferably, the illumination means are solid state light emitting diodes. Alternatively, the illumination means comprises light bulbs and a light focusing means.

[0026] Preferably, the camera has a high sensitivity to low light. Ideally, the sensitivity level of the camera is <0.05 lux.

[0027] Preferably, the camera lens is between 5 and 8mm in diameter.

[0028] Preferably, the ophthalmic lens is in the range of 20 to 40 dioptries. Ideally, the ophthalmic lens is 20 dioptries.

[0029] Preferably, the ophthalmic camera further comprises focusing means. Ideally, the focusing means takes the form of movement means operable to move the ophthalmic lens linearly along the alignment axis.

[0030] Preferably, the ophthalmic lens is equal to or smaller than the camera lens.

[0031] In accordance with a second embodiment of the present invention there is an ophthalmic camera adaptor comprising:

at least one illumination means; and

an ophthalmic lens,

where, the centres of the ophthalmic lens and camera lens are aligned to form an alignment axis and where the at least one illumination means is capable of linear movement along a radial axis of the camera lens and pivotal movement about the radial plane incorporating radial axis and alignment axis, such that the circle of light emitted by the at least one illumination means is constantly directed to the centre of the ophthalmic lens.

[0032] The ophthalmic camera adaptor has all of the additional features of the ophthalmic camera as appropriate.

[0033] In accordance with a third embodiment of the present invention, there is a wearable frame having at least one ophthalmic camera according to the first embodiment of the invention fixed thereon.

[0034] In accordance with a fourth embodiment of the present invention, there is a wearable frame having at least one ophthalmic camera according to the first embodiment of the invention slidably mounted thereon.

[0035] In accordance with a fifth embodiment of present invention, there is a method of determining a glucose level of a patient using an ophthalmic camera or ophthalmic camera adaptor as defined above, comprising:

emitting a beam of light having a wavelength in the range 670 to 590nm into a pupil of the patient;

taking an image of the pupil using a camera having an associated ophthalmic lens of at least 20X magnification; and

determining the glucose level of the patient from information ascertainable from the image of blood in the veins of the optic disc.

[0036] In accordance with a sixth embodiment of the present invention, there is a method of determining a haemoglobin level of a patient using an ophthalmic camera or ophthalmic camera adaptor as defined above, comprising:

emitting a beam of light having a wavelength in the range 570 to 590nm into a pupil of the patient;

taking an image of the pupil using a camera having an associated ophthalmic lens of at least 20x magnification;

determining the haemoglobin level of the patient from the image of the macula.

Brief Description of the Drawings

[0037] The invention will now be described, by way of example only, with reference to the accompanying drawings, of which:

Figure 1 is a schematic of the optics of an ophthalmic camera and ophthalmic camera adaptor of the present invention.

Figure 2 is an isometric view of the optics of the ophthalmic camera and ophthalmic camera adaptor shown in Figure 1.

Figures 3a and 3b are isometric views of an ophthalmic

mic camera adaptor of the present invention.

Figure 4 is a block diagram of an embodiment of the ophthalmic camera of the present invention.

Figure 5 is an isometric view of a frame arrangement for the ophthalmic camera of the present invention with the ophthalmic camera situate thereon.

Best Mode(s) for Carrying Out the Invention

[0038] In accordance with a first embodiment of the invention there is provided an ophthalmic camera 100 comprising a monochromatic camera 102 highly sensitive to low light (ie. somewhere in the range of <0.05 lux), a plurality of solid-state LED 104 and an ophthalmic lens 106 all contained within a housing (not shown).

[0039] The monochromatic camera 102 has a camera lens 108. Ideally, the camera lens 108 has a diameter of 5-8mm. This is because lenses of a greater diameter have been found to produce circular occlusions on the resulting image.

[0040] The plurality of LEDs 104 surround the circumference of the camera lens 108 and are linked to a control unit 110. Each LED 104 is equidistant to its adjacent LEDs. 104.

[0041] LEDs 104 are able to move linearly along their respective radial axes (marked A through E). Each LED 104 is able to pivot towards, or away from the camera lens 108 about the plane (marked A' through E') extending from its respective radial axis A-E.

[0042] The ophthalmic lens 106 has an inner surface 121 which opposes the camera lens 118. The centre of the camera lens 118 aligns with the centre of the inner surface 121. Ideally, the ophthalmic lens 106 is of the same size as, or smaller than, camera lens 108 and positioned within optical axis X of the monochromatic camera 102.

[0043] The ophthalmic lens 106 is typically in the range of 20 to 40 dioptres, with 20 dioptres considered optimal. To allow for focusing of the ophthalmic lens 106, the ophthalmic lens 106 is capable of linear movement along optical axis X of the monochromatic camera 102.

[0044] The position of the LEDs 104 is a function of the current setting of the ophthalmic camera 100. Each setting of the ophthalmic camera 100 represents a range of pupil 101 sizes. To elaborate,

- setting 1 is used for pupils 101 of size less than 3mm;
- setting 2 is used for pupils 101 having a size between 3-4mm; and
- setting 3 is used for dilated pupils 101.

[0045] Upon choosing a setting LEDs 104 move, from their present linear and pivotal position, linearly along their respective radial axes (marked A through F) and

pivot about their respective axial plane (marked A' through F') to the position represented by the newly chosen setting, such that, at this new position, the centre of the circle generated by the light emitted by the LED 104 at the point of intersection with the ophthalmic lens 116 is substantially equal to the centre of the inner surface 121 thereof.

[0046] In the embodiment shown:

- LED 112 generates a homogenous blue light having a wavelength somewhere in the range 450 to 490nm;
- LED 114 generates a homogenous green light having a wavelength somewhere in the range of 491 to 559nm;
- LED 116 generates a homogenous yellow light having a wavelength somewhere in the range 560 to 595nm;
- LED 118 generates a homogenous red light having a wavelength somewhere in the range 596 to 699nm; and
- LED 120 generates a homogenous infrared light having a wavelength of 700nm.
- LED 123 generates a white light having a wavelength spanning the spectrum of 390nm to 699nm.

[0047] Ideally, LEDs 112, 114, 116, 118 and 120 have wavelengths of 490nm, 540nm, 590nm, 630nm and 700nm, respectively.

[0048] The optical arrangement described above is shown in Figure 1.

[0049] In use, the user manipulates the control unit 110 to illuminate one off the LEDs 104. The LED 104 that is illuminated is determined by the area of the eye to be imaged. In this regard:

- if an image of the optic nerve fibres is desired, blue LED 112 is illuminated;
- if an image of the cotton wool spots or veins is desired, green LED 114 is illuminated;
- If an image useful for diabetic retinopathy or an image of the eye 103 of good overall contrast is desired, yellow LED 116 is illuminated;
- If an image of the surface of the choroids is desired, red LED 118 is illuminated. Depending on the wavelength of the red LED 118, the captured image may show some element of the choroid below the surface:
- if an image of elements below the surface of the choroid is desired, infrared LED 120 is illuminated; and

- If a standard image of the eye is desired, white LED 123 is illuminated.

[0050] Once the desired LED 104 is illuminated, the ophthalmic lens 106 is moved along optical axis X until the image to be captured; as determined at the point of the monochromatic camera 102, is focused. The image can then be captured as per the mechanisms for doing so provided by the monochromatic camera 102 used. Ideally, LED 116 has a wavelength in the range 570 to 590nm. Taking an image using LED 116 with an ophthalmic lens 106 having 20x magnification, allows a clear, sizable, picture of the veins of the optic disc and the macula. Using this image, the glucose level of the patient can be determined from the level of blood shown in the veins of the optic disc. Similarly, or alternatively, the haemoglobin level of the patient can be determined from the image of the maoula.

[0051] In accordance with a second embodiment of the invention, where like numerals reference like parts, there is an ophthalmic camera adaptor 200. The ophthalmic camera adaptor 200 is shown in Figures 3a and 3b.

[0052] The ophthalmic camera adaptor 200 consists of a body 202. In the embodiment being described, body 202 is substantially rectangular in shape and has a rear face 204, two sides 206a, 206b and a front face 208.

[0053] Located centrally about rear face 204 is an aperture 210. Aperture 210 extends through the ophthalmic adaptor 200 such that aperture 210 is also located centrally about front face 208. Situate adjacent aperture 210 is an interface contact 212.

[0054] adjacent face 204 are two snap clips 214a, 214b. Snap clip 214a extends from side 206a, while snap clip 214b extends from side 206b. Each snap clip 214 has an internal recess 216 positioned such that, when appropriate pressure is applied, the snap clips 214 can flex towards aperture 210. Snap clips 214a, 214b are adapted to be releasably retained within grooves on the body of a camera (not, shown) to which it is ultimately attached.

[0055] Surrounding front face 208, and extending along a portion of sides 206 towards rear face 204, is a rubber overmoulding 218, Rubber overmoulding 218 covers a portion 220 of each snap clip 214. Finger grips 222 are formed within the external surface 224 of rubber overmoulding 218 at a position substantially adjacent portion 220.

[0056] The optics of the ophthalmic adaptor 200 comprise a plurality of coloured LEDs 104 substantially equidistantly disposed around the circumference of aperture 210. The LEDs 104 comprise a blue LED 112, green LED 114, yellow LED 118, red LED 118, infrared 120 and white LED 123. The wavelengths of each LED 112, 114, 116, 118, 120, 123 is as set out in respect of the first embodiment of the invention.

[0057] Each LED 104 is connected to the interface contact 212 such that control of the LED is facilitated through the interface contact 212.

[0058] The light emitted by each LED 104 is directed towards the ophthalmic lens 108 as described in the first embodiment of the invention. The ophthalmic lens 108 is positioned in the aperture 210 such that the ophthalmic lens 108 is substantially flush with front face 208. However, the ophthalmic lens 108 is capable of linear movement along aperture 210 so as to allow for focusing of the image to be captured.

[0059] When the ophthalmic adaptor 200 is releasably retained within the grooves on the body of the camera, the following situation exists:

- aperture 210 aligns with the optical axis X of the camera, such that at least a portion of the optical axis X is not obscured by the remainder of the adaptor (excluding ophthalmic lens 108);
- interface contact 212 forms a connection with the camera such that the camera may perform the same functions as control unit 110; and
- the external surface 224 of rubber overmoulding 218 may sit flush with the external surface of the camera.

[0060] In accordance with a third embodiment of the invention, where like numerals refer to like parts, the control unit 110 is replaced with an electronic control system 300. The electronic control system 300 includes a power supply 302. The power supply 302, through electronic control system 300, provides power to the monochromatic camera 102 and LEDs 104. In all other respects, the electronic control system is equivalent to the control unit 110. The electronic control system is, however, connected to a computer 304.

[0061] Additionally, the monochromatic camera 102 is a digital camera with two output parts. The first output port is connected to computer 304. The second output port is optionally, connected to a monitor 306. .

[0062] During use of the ophthalmic camera 100, details of the settings of the ophthalmic camera 100 are communicated to the computer 304 by the electronic control system 300. As images are captured, the monochromatic camera 102 also provides a digitised version of the image to computer 304. Software stored on computer 304 allows the combination of digitised image and setting details to be manipulated in a manner as desired by the user.

[0063] For instance, a pseudo-colour picture can be formed for diagnostic use by combining images captured using three different wavelength images. Alternatively, a monochromatic reference image may be taken using a single wavelength. The image can then be manipulated to create a 3-band false colour image. The false colour image can then be colour-matched with a colour image taken with a fundus camera (not shown) and the resulting colour-matched image used for diagnostic purposes.

[0064] The monitor 306 receives constant information from the monochromatic camera 102 representing the

image presently within its optical axis X. In this manner, the user can, by viewing the image on monitor 305, decide whether to capture the then current image or not.

[0065] In accordance with a fourth embodiment of the invention, where like numerals reference like parts, there is provided a frame 400 for the ophthalmic camera of the first embodiment comprising a cross-member 402 and a plurality of supporting members 404.

[0066] Cross-member 402 is attached to supporting member 404a at one end thereof and attached to supporting member 404b at the other end.

[0067] Supporting member 404a and 404b are substantially perpendicular to cross-member 402 and substantially parallel to each other. At the unattached end of each supporting member 404a, 404b, is a curved hook-like arrangement 406a, 406b.

[0068] Supporting member 404c is "L"-shaped and attached at a point substantially central to cross-member 402. Supporting member 404c protrudes in the same direction relative to cross-member 402 as curved hook-like arrangements 406a, 406b. The portion of supporting member 404c not attached to cross-member 402 extends towards the curved hook-like arrangements 406a, 406b.

[0069] A "C"-shaped portion 408 is attached to the open end of supporting member 404c, such that the open area 410 of the "C"-shaped portion 408 is unobstructed.

[0070] Attached to cross-member 402 is the ophthalmic camera 100 of the first embodiment of the invention. The ophthalmic camera 100 can be moved along the full length of cross-member 402. Again, this arrangement is possible due to the minimal size of the optical setup of the ophthalmic camera 100.

[0071] The end result is that the frame 400 is similar in structure to standard glass frames.

[0072] In use, the operator of the ophthalmic camera 100 places the frame 400 on their face such that hook-like arrangements 406a, 406b fit around the ear of the operator and the open area 410 of the "C"-shaped portion 408 cups the nose of the operator.

[0073] When placed on the face of the operator, the ophthalmic camera 100 is spaced therefrom by the length of the supporting members 406. The operator may then operate the ophthalmic camera 100 as mentioned above to capture an image of one of the patient's eyes. Once the image is captured, the ophthalmic camera 100 can then be moved along cross-member 102 to allow an image to be captured of the patient's other eye.

[0074] The frame 400 is then removed from the face of the operator and the hook-like arrangements 406a, 406b inverted. The operator may then replace the frame on their face to capture an image of the patient's other eye.

[0075] In accordance with a fifth embodiment of the invention, where like numerals reference like parts, there is provided a frame 500 for the ophthalmic camera of the first embodiment comprising a cross-member 502 and plurality of supporting members 504.

[0076] Cross-member 502 is attached to supporting member 504a at one end thereof and attached to sup-

porting member 504b at the other end.

[0077] Supporting members 504a and 504b are substantially perpendicular to cross-member 502 and substantially parallel to each other. At the unattached end of each supporting member 504a, 504b is a curved hook-like arrangement 506a, 506b. The hook-like arrangements 506a, 506b are capable of inversion.

[0078] Supporting member 504c is "L"-shaped and attached at a point substantially central to cross-member 502. Supporting member 504c protrudes in the same direction relative to cross-member 502 as curved hook-like arrangements 506a, 506b. The portion of supporting member 504c not attached to cross-member 502 extends towards the curved hook-like arrangements 506a, 506b.

[0079] A "C"-shaped portion 508 is attached to the open end of supporting member 504c such that the open area 510 of the "C"-shaped portion 508 is unobstructed.

[0080] Attached to cross-member 502 at a position between supporting members 504c and 504a or between supporting members 504c and 504b is the ophthalmic camera 100 of the first embodiment of the invention. The ophthalmic camera 100 can be moved along the cross-member 502, the movement of the ophthalmic camera 100 being bound by supporting member 504a and 504c or supporting members 504c and 504b, as appropriate. This arrangement is possible due to the minimal size of the optical setup of the ophthalmic camera 100.

[0081] The end result is that the frame 500 is similar in structure to standard glass frames.

[0082] In use, the operator of the ophthalmic camera 100 places the frame 500 on their face such that hook-like arrangements 506a, 506b fit around the ear of the operator and the open area 510 of the "C"-shaped portion 508 cups the nose of the operator.

[0083] When placed on the face of the operator, the ophthalmic camera 100 is spaced therefrom by the length of the supporting members 506. The operator may then operate the ophthalmic camera 100 as mentioned above to capture an image of one of the patient's eyes.

[0084] The frame 500 is then removed from the face of the operator and the hook-like arrangements 506a, 506b inverted. The operator may then replace the frame on their face to capture an image of the patient's other eye.

[0085] It should be noted that the inversion means used in this embodiment must be semi-rigid to ensure that the frame 500 does not fall away from the operator's face through reason of an unintended inversion of the hook-like arrangements 506a, 506b.

[0086] In accordance with a sixth embodiment of the invention, where like numerals reference like parts, the fourth embodiment of the invention is modified to include a second ophthalmic camera 100. In this arrangement, the ophthalmic cameras 100 are identical in their configuration such that the operator can take pictures of both of the patient's eyes without the need for removal of the frame 400. It is therefore unnecessary, in this arrangement, for hook-like arrangements 406a, 406b to be In-

vertible.

[0087] It should be appreciated by the person skilled in the art that the present invention is not limited to the above embodiments and that variations and modifications thereof are considered to be within the scope of the invention. In particular, the following modifications and variations fall within the scope of the invention:

- monochromatic camera 102 may be replaced with a colour camera (which may or may not result in a need for other filters). Additionally, monochromatic camera 102, or colour camera (as appropriate), may be a digital camera or an analog camera coupled with digitising means for generating a digital representation of the analog image taken by the analog camera.
- the ophthalmic lens 106 may be replaced with any other type of lens.
- the ophthalmic camera 100 may include a spectrometer. In such an arrangement the image taken by the ophthalmic camera 100 may be analysed by the spectrometer to produce a spectroscopic graph of the image. The spectroscopic graph can then be used in measuring the glucose or haemoglobin levels of the patient. Alternatively, images taken by the ophthalmic camera 100 may be subjected to the aforementioned analysis by an external spectrometer.
- the plurality of LEDs 104 may be set on a time delay arrangement, whereby each, or a subset of, LEDs 104 are illuminated in sequence and for a predetermined period of time;
- the plurality of LEDs 104 may be replaced with a single LED disposed about the circumference of the camera lens 108;
- the plurality of LEDs 104 may be arranged such that each LED 104 is of the same colour but of a differing wavelength.
- the ophthalmic camera 100 and ophthalmic camera adaptor 100 may include magnification lenses. Each magnification lens is associated with at least one setting, such that, on choosing the setting, the magnification lens is positioned within the optical axis X of the monochromatic camera 102 and in-between the ophthalmic lens 116 and the camera lens 118.
- An alternate number of settings may be used than has been described herein. Alternatively, rather than having settings that move the LEDs 104 to predefined positions, the linear and pivotal movement of LEDs 104 may be facilitated through separate manual controls.

- The linear and pivotal movement of LEDs 104 may be facilitated through a single manual control.
- Control unit 120 may be adapted to control the linear and pivotal movement of LEDs 104 based on the determined size of the pupil 121. to be examined.
- the linear movement of the ophthalmic lens 108 as a means of focusing the image to be captured can be replaced by other focusing structures.
- the adaptor structure mentioned above can be replaced with any other structure incorporating the optical arrangement mentioned.
- the interface contract 212 may be omitted and in its place control unit 110 may be in-built into the adaptor.
- image manipulation techniques or procedures, other than those mentioned above, may be used to create an image useful for diagnostic purposes.
- power supply 302 may take the form of a mains adaptor or a battery
- the inversion means of frame 500 may take the form, amongst others, of deformable hook-like arrangements 506a, 506b or hook-like arrangements 506a, 506b that are rotatable about supporting members 506a, 506b respectively.

[0088] It should be further appreciated by the person skilled in the art that features and modifications discussed above, not being alternatives or substitutes, can be combined to form yet other embodiments that fall within the scope of the invention described.

Claims

1. An ophthalmic camera apparatus comprising a camera (102) having a camera lens (108), at least one illumination means (104) and an ophthalmic lens (106), **characterised in that** the centres of the ophthalmic lens (106) and camera lens (108) are aligned to form an alignment axis (X) and where the at least one illumination means (104) is capable of linear movement along a radial axis (A-E) of the camera lens (108) and pivotal movement about the radial plane (A'-E') incorporating radial axis and alignment axis, such that the circle of light emitted by the at least one illumination means (104) is constantly directed to the centre of the ophthalmic lens (106).
2. An ophthalmic apparatus according to claim 1, wherein the camera (102) is a digital camera or an analogue camera with digitising means for producing a digital representation of analogue images taken by

- the analogue camera.
3. An ophthalmic apparatus according to claims 1 or 2, where each of the at least one illumination means (104) surrounds the circumference of the camera lens (108). 5
 4. An ophthalmic apparatus according to claim 3, where each illumination means (104) is equidistant from its adjacent illumination means. 10
 5. An ophthalmic apparatus according to any preceding claim, where the camera (102) has a high sensitivity to low light. 15
 6. An ophthalmic apparatus according to claim 5, where the sensitivity level of the camera is <0.05 lux. 20
 7. An ophthalmic apparatus according to any preceding claim, where the camera lens (108) is between 5 and 8mm in diameter. 25
 8. An ophthalmic apparatus according to any preceding claim, where the ophthalmic lens (108) is equal to or smaller than the camera lens (108) in size. 30
 9. An ophthalmic camera adaptor apparatus (200) comprising at least one illumination means (104); and an ophthalmic lens (106), wherein the ophthalmic apparatus (200) is arranged for connection to a camera having a camera lens **characterised in that**, in use, the centres of the ophthalmic lens (106) and camera lens (108) are aligned to form an alignment axis (X) and where the at least one illumination means (104) is capable of linear movement along a radial axis (A-E) of the camera lens (108) and pivotal movement about the radial plane (A'-E') incorporating radial axis and alignment axis, such that the circle of light emitted by the at least one illumination means (104) is constantly directed to the centre of the ophthalmic lens (106). 35
 10. An ophthalmic apparatus according to any preceding claim, further comprising selection means for choosing from a plurality of settings, each setting representing a pupil size or range of pupil sizes, such that, when the setting is changed, the at least one illumination means (104) moves linearly along its radial axis (A-E) to the position specified by the new setting and pivots about the radial plane (A'-E') until the circle of light emitted by the at least one illumination means is directed on the centre of the ophthalmic lens. 40
 11. An ophthalmic apparatus according to any preceding claim, where the linear and pivotal movement of the at least one illumination means (104) is controlled by one or more manual controls. 45
 12. An ophthalmic apparatus according to any of claims 1 to 10, further comprising automated measuring means for obtaining a measurement of the size of the pupil to be examined, the automated measuring means also controlling the linear and pivotal movement of the at least one illumination means (104) to a position determined best for the measured pupil size. 50
 13. An ophthalmic apparatus according to any preceding claim, further comprising at least one magnification lens, each magnification lens being associated with at least one linear position of the at least one illumination means (104), such that the linear position of the at least one illumination means determines which magnification lens are positioned within the alignment axis (X). 55
 14. An ophthalmic apparatus according to any preceding claim, where one of the at least one illumination means (104) has a wavelength in the range 450 to 490nm. 60
 15. An ophthalmic apparatus according to claim 14, where the illumination means (104) has a wavelength of 490nm. 65
 16. An ophthalmic apparatus according to any preceding claim, where one of the at least one illumination means (104) has a wavelength in the range 491 to 559nm. 70
 17. An ophthalmic apparatus according to claim 16, where the illumination means (104) has a wavelength of 540nm. 75
 18. An ophthalmic apparatus according to any preceding claim, where one of the at least one illumination means (104) has a wavelength in the range 560 to 595nm. 80
 19. An ophthalmic apparatus according to claim 18, where the illumination means (104) has a wavelength of 590nm. 85
 20. An ophthalmic apparatus according to any preceding claim, where one of the at least one illumination means (104) has a wavelength in the range 596 to 699nm. 90
 21. An ophthalmic apparatus according to claim 20, where the illumination means (104) has a wavelength of 630nm. 95
 22. An ophthalmic apparatus according to any preceding claim, where one of the at least one illumination means (104) has a wavelength of 700nm. 100

23. An ophthalmic apparatus according to any preceding claim, where one of the at least one illumination means (104) produces white light.
24. An ophthalmic apparatus according to any preceding claim, where the at least one illumination means (104), or a subset of the at least one illumination means, is illuminated in accordance with a predetermined sequence.
25. An ophthalmic apparatus according to any preceding claim including at least one interface means (212) for connecting to at least one of the following: an external computer, an external monitor, an external spectrometer.
26. An ophthalmic apparatus according to any preceding claim, further comprising a spectrometer, the spectrometer operable to produce a spectroscopic graph of images taken by the camera.
27. An ophthalmic apparatus according to any preceding claim, where the at least one illumination means (104) is of variable intensity.
28. An ophthalmic apparatus according to claim 27, where the level of intensity of the at least one illumination means (144) is a function of a pupil colour setting of the ophthalmic device.
29. An ophthalmic apparatus according to any preceding claim, where the illumination means (104) are solid state light emitting diodes.
30. An ophthalmic apparatus according to any one of claims 1 to 28, where the illumination means (104) comprises light bulbs and a light focusing means.
31. An ophthalmic apparatus according to any preceding claim, where the ophthalmic lens (106) is in the range of 20 to 40 dioptres.
32. An ophthalmic apparatus according to claim 31, where the ophthalmic lens (106) is 20 dioptres.
33. An ophthalmic apparatus according to any preceding claim, further comprising focusing means.
34. An ophthalmic apparatus according to claim 33, where the focusing means takes the form of movement means operable to move the ophthalmic lens (106) linearly along the alignment axis (X).
35. A wearable frame (400) having at least one ophthalmic apparatus according to claim 1, and any of claims 9 and 11 to 34 when dependent upon claim 1, fixed thereon.

5

10

15

20

25

30

35

40

45

50

55

36. A wearable frame (400) having at least one ophthalmic apparatus according to claim 1, and any of claims 9 and 11 to 34 when dependent upon claim 1, slidably mounted thereon.

37. A method of determining a glucose level of a patient using the ophthalmic apparatus according to any one of claims 1 to 34, comprising: emitting a beam of light having a wavelength in the range 570 to 590nm into a pupil of the patient; taking an image of the pupil using a camera (102) having an associated ophthalmic lens (106) of at least 20x magnification; and determining the glucose level of the patient from the level of blood in the veins of the optic disc.

38. A method of determining a haemoglobin level of a patient using the ophthalmic apparatus according to any one of claims 1 to 34, comprising: emitting a beam of light having a wavelength in the range 570 to 590nm into a pupil of the patient; taking an image of the pupil using a camera (902) having an associated ophthalmic lens (106) of at least 20x magnification; and determining the haemoglobin level of the patient from the image of the macula.

Patentansprüche

- Ophthalmische Kameravorrichtung mit einer Kamera (102), die eine Kameralinse (108) aufweist, mindestens einer Beleuchtungseinrichtung (104) und einer ophthalmischen Linse (106), **dadurch gekennzeichnet, dass** die Zentren der ophthalmischen Linse (106) und der Kameralinse (108) ausgerichtet sind, um eine Ausrichtungsachse (X) zu bilden, und wobei die mindestens eine Beleuchtungseinrichtung (104) zu einer geradlinigen Bewegung entlang einer radialen Achse (A-E) der Kameralinse (108) und zu einer Schwenkbewegung um die radiale Ebene (A'-E'), die die radiale Achse und die Ausrichtungsachse enthält, in der Lage ist, so dass der Kreis von Licht, das von der mindestens einen Beleuchtungseinrichtung (104) emittiert wird, konstant auf das Zentrum der ophthalmischen Linse (106) gerichtet wird.
- Ophthalmische Vorrichtung nach Anspruch 1, wobei die Kamera (102) eine Digitalkamera oder eine Analogkamera mit einer Digitalisierungseinrichtung zum Erzeugen einer digitalen Darstellung von durch die Analogkamera aufgenommenen analogen Bildern ist.
- Ophthalmische Vorrichtung nach Anspruch 1 oder 2, wobei jede der mindestens einen Beleuchtungseinrichtung (104) den Umfang der Kameralinse (108) umgibt.
- Ophthalmische Vorrichtung nach Anspruch 3, wobei

- jede Beleuchtungseinrichtung (104) von ihrer benachbarten Beleuchtungseinrichtung gleich beabstandet ist.
5. Ophthalmische Vorrichtung nach einem vorangehenden Anspruch, wobei die Kamera (102) eine hohe Empfindlichkeit gegen schwaches Licht aufweist. 5
6. Ophthalmische Vorrichtung nach Anspruch 5, wobei das Empfindlichkeitsniveau der Kamera $< 0,05$ Lux ist. 10
7. Ophthalmische Vorrichtung nach einem vorangehenden Anspruch, wobei die Kameralinse (108) einen Durchmesser zwischen 5 und 8 mm aufweist. 15
8. Ophthalmische Vorrichtung nach einem vorangehenden Anspruch, wobei die ophthalmische Linse (106) hinsichtlich der Größe gleich oder kleiner als die Kameralinse (108) ist. 20
9. Ophthalmische Kameraadaptervorrichtung (200) mit mindestens einer Beleuchtungseinrichtung (104); und einer ophthalmischen Linse (106), wobei die ophthalmische Vorrichtung (200) zur Verbindung mit einer Kamera mit einer Kameralinse angeordnet ist, **dadurch gekennzeichnet, dass** bei der Verwendung die Zentren der ophthalmischen Linse (106) und der Kameralinse (108) ausgerichtet sind, um eine Ausrichtungsachse (X) zu bilden, und wobei die mindestens eine Beleuchtungseinrichtung (104) zu einer geradlinigen Bewegung entlang einer radialen Achse (A-E) der Kameralinse (108) und zu einer Schwenkbewegung um die radiale Ebene (A'-E'), die die radiale Achse und die Ausrichtungsachse enthält, in der Lage ist, so dass der Kreis des Lichts, das von der mindestens einen Beleuchtungseinrichtung (104) emittiert wird, konstant auf das Zentrum der ophthalmischen Linse (106) gerichtet wird. 25
30
35
40
10. Ophthalmische Vorrichtung nach einem vorangehenden Anspruch, die außerdem eine Auswahleinrichtung zum Auswählen aus mehreren Einstellungen aufweist, wobei jede Einstellung eine Pupillengröße oder einen Bereich von Pupillengrößen darstellt, so dass, wenn die Einstellung geändert wird, die mindestens eine Beleuchtungseinrichtung (104) sich geradlinig entlang ihrer radialen Achse (A-E) in die durch die neue Einstellung festgelegte Position bewegt und um die radiale Ebene (A'-E') schwenkt, bis der Kreis des Lichts, das von der mindestens einen Beleuchtungseinrichtung emittiert wird, auf das Zentrum der ophthalmischen Linse gerichtet ist. 45
11. Ophthalmische Vorrichtung nach einem vorangehenden Anspruch, wobei die geradlinige und die Schwenkbewegung der mindestens einen Beleuchtungseinrichtung (104) durch eine oder mehrere ma-
- nuelle Steuerungen gesteuert werden.
12. Ophthalmische Vorrichtung nach einem der Ansprüche 1 bis 10, die außerdem eine automatisierte Messeinrichtung zum Erhalten einer Messung der Größe der zu untersuchenden Pupille aufweist, wobei die automatisierte Messeinrichtung auch die geradlinige und die Schwenkbewegung der mindestens einen Beleuchtungseinrichtung (104) in eine Position, die als für die gemessene Pupillengröße am besten bestimmt wird, steuert. 5
13. Ophthalmische Vorrichtung nach einem vorangehenden Anspruch, die außerdem mindestens eine Vergrößerungslinse aufweist, wobei jede Vergrößerungslinse mindestens einer linearen Position der mindestens einen Beleuchtungseinrichtung (104) zugeordnet ist, so dass die lineare Position der mindestens einen Beleuchtungseinrichtung bestimmt, welche Vergrößerungslinse innerhalb der Ausrichtungsachse (X) positioniert wird. 10
14. Ophthalmische Vorrichtung nach einem vorangehenden Anspruch, wobei eine der mindestens einen Beleuchtungseinrichtung (104) eine Wellenlänge im Bereich von 450 bis 490 nm aufweist. 25
15. Ophthalmische Vorrichtung nach Anspruch 14, wobei die Beleuchtungseinrichtung (104) eine Wellenlänge von 490 nm aufweist. 30
16. Ophthalmische Vorrichtung nach einem vorangehenden Anspruch, wobei eine der mindestens einen Beleuchtungseinrichtung (104) eine Wellenlänge im Bereich von 491 bis 559 nm aufweist. 35
17. Ophthalmische Vorrichtung nach Anspruch 16, wobei die Beleuchtungseinrichtung (104) eine Wellenlänge von 540 nm aufweist. 40
18. Ophthalmische Vorrichtung nach einem vorangehenden Anspruch, wobei eine der mindestens einen Beleuchtungseinrichtung (104) eine Wellenlänge im Bereich von 560 bis 595 nm aufweist. 45
19. Ophthalmische Vorrichtung nach Anspruch 18, wobei die Beleuchtungseinrichtung (104) eine Wellenlänge von 590 nm aufweist. 50
20. Ophthalmische Vorrichtung nach einem vorangehenden Anspruch, wobei eine der mindestens einen Beleuchtungseinrichtung (104) eine Wellenlänge im Bereich von 596 bis 699 nm aufweist. 55
21. Ophthalmische Vorrichtung nach Anspruch 20, wobei die Beleuchtungseinrichtung (104) eine Wellenlänge von 630 nm aufweist. 55

22. Ophthalmische Vorrichtung nach einem vorangehenden Anspruch, wobei eine der mindestens einen Beleuchtungseinrichtung (104) eine Wellenlänge von 700 nm aufweist.
23. Ophthalmische Vorrichtung nach einem vorangehenden Anspruch, wobei eine der mindestens einen Beleuchtungseinrichtung (104) weißes Licht erzeugt.
24. Ophthalmische Vorrichtung nach einem vorangehenden Anspruch, wobei die mindestens eine Beleuchtungseinrichtung (104) oder eine Teilmenge der mindestens einen Beleuchtungseinrichtung gemäß einer vorbestimmten Sequenz erleuchtet wird.
25. Ophthalmische Vorrichtung nach einem vorangehenden Anspruch mit mindestens einer Schnittstelleneinrichtung (212) zum Verbinden mit mindestens einem der folgenden: einem externen Computer, einem externen Monitor, einem externen Spektrometer.
26. Ophthalmische Vorrichtung nach einem vorangehenden Anspruch, die außerdem ein Spektrometer aufweist, wobei das Spektrometer betriebsfähig ist, um einen spektroskopischen Graphen von durch die Kamera aufgenommenen Bildern zu erzeugen.
27. Ophthalmische Vorrichtung nach einem vorangehenden Anspruch, wobei die mindestens eine Beleuchtungseinrichtung (104) eine variable Intensität aufweist.
28. Ophthalmische Vorrichtung nach Anspruch 27, wobei der Intensitätspegel der mindestens einen Beleuchtungseinrichtung (104) eine Funktion einer Pupillenfarbeinstellung der ophthalmischen Vorrichtung ist.
29. Ophthalmische Vorrichtung nach einem vorangehenden Anspruch, wobei die Beleuchtungseinrichtung (104) Festkörper-Leuchtdioden sind.
30. Ophthalmische Vorrichtung nach einem der Ansprüche 1 bis 28, wobei die Beleuchtungseinrichtung (104) Glühlampen und eine Lichtfokussiereinrichtung aufweist.
31. Ophthalmische Vorrichtung nach einem vorangehenden Anspruch, wobei die ophthalmische Linse (106) im Bereich von 20 bis 40 Dioptrien liegt.
32. Ophthalmische Vorrichtung nach Anspruch 31, wobei die ophthalmische Linse (106) 20 Dioptrien aufweist.
33. Ophthalmische Vorrichtung nach einem vorangehenden Anspruch, die außerdem eine Fokussiereinrichtung aufweist.
34. Ophthalmische Vorrichtung nach Anspruch 33, wobei die Fokussiereinrichtung die Form einer Bewegungseinrichtung annimmt, die betriebsfähig ist, um die ophthalmische Linse (106) geradlinig entlang der Ausrichtungsachse (X) zu bewegen.
35. Tragbarer Rahmen (400) mit mindestens einer daran befestigten ophthalmischen Vorrichtung nach Anspruch 1 und einem der Ansprüche 9 und 11 bis 34, wenn in Abhängigkeit von Anspruch 1.
36. Tragbarer Rahmen (400) mit mindestens einer verschiebbar daran angebrachten ophthalmischen Vorrichtung nach Anspruch 1 und einem der Ansprüche 9 und 11 bis 34, wenn in Abhängigkeit von Anspruch 1.
37. Verfahren zum Bestimmen eines Glukosespiegels eines Patienten unter Verwendung der ophthalmischen Vorrichtung nach einem der Ansprüche 1 bis 34, das umfasst: Emittieren eines Lichtstrahls mit einer Wellenlänge im Bereich von 570 bis 590 nm in eine Pupille des Patienten; Aufnehmen eines Bildes der Pupille unter Verwendung einer Kamera (102) mit einer zugehörigen ophthalmischen Linse (106) mit einer mindestens 20-fachen Vergrößerung; und Bestimmen des Glukosespiegels des Patienten aus dem Blutspiegel in den Venen der Sehnervenscheibe.
38. Verfahren zum Bestimmen eines Hämoglobinspiegels eines Patienten unter Verwendung der ophthalmischen Vorrichtung nach einem der Ansprüche 1 bis 34, das umfasst: Emittieren eines Lichtstrahls mit einer Wellenlänge im Bereich von 570 bis 590 nm in eine Pupille des Patienten; Aufnehmen eines Bildes der Pupille unter Verwendung einer Kamera (102) mit einer zugehörigen ophthalmischen Linse (106) mit einer mindestens 20-fachen Vergrößerung; und Bestimmen des Hämoglobinspiegels des Patienten aus dem Bild der Makula.

Revendications

1. Dispositif d'appareil photographique ophtalmique comportant un appareil photographique (102) ayant un objectif d'appareil photographique (108), au moins un moyen d'éclairage (104) et une lentille ophtalmique (106), **caractérisé en ce que** les centres de la lentille ophtalmique (106) et de l'objectif de l'appareil photographique (108) sont alignés afin de former un axe d'alignement (X) et où le au moins un moyen d'éclairage (104) est capable d'effectuer un mouvement linéaire le long d'un axe radial (A-E) de

- l'objectif de l'appareil photographique (108) et un mouvement de pivotement autour du plan radial (A'-E') incorporant un axe radial et un axe d'alignement, de sorte que le cercle de lumière émis par le au moins un moyen d'éclairage (104) est constamment dirigé vers le centre de la lentille ophtalmique (106).
2. Dispositif ophtalmique selon la revendication 1, dans lequel l'appareil photographique (102) est un appareil photographique numérique ou un appareil photographique analogique ayant des moyens de numérisation pour produire une représentation numérique d'images analogiques prises par l'appareil photographique analogique.
 3. Dispositif ophtalmique selon les revendications 1 ou 2, dans lequel chacun du au moins un moyen d'éclairage (104) entoure la circonférence de l'objectif de l'appareil photographique (108).
 4. Dispositif ophtalmique selon la revendication 3, dans lequel chaque moyen d'éclairage (104) est équidistant par rapport à ses moyens d'éclairage adjacents.
 5. Dispositif ophtalmique selon l'une quelconque des revendications précédentes, dans lequel l'appareil photographique (102) a une forte sensibilité à une faible lumière.
 6. Dispositif ophtalmique selon la revendication 5, dans lequel le niveau de sensibilité de l'appareil photographique est $< 0,05$ lux.
 7. Dispositif ophtalmique selon l'une quelconque des revendications précédentes, dans lequel l'objectif de l'appareil photographique (108) a un diamètre compris entre 5 et 8 mm.
 8. Dispositif ophtalmique selon l'une quelconque des revendications précédentes, dans lequel la lentille ophtalmique (106) a une taille égale ou inférieure à l'objectif de l'appareil photographique (108).
 9. Dispositif adaptateur d'appareil photographique ophtalmique (200) comportant au moins un moyen d'éclairage (104) ; et une lentille ophtalmique (106), dans lequel le dispositif ophtalmique (200) est agencé en vue d'une connexion à un appareil photographique ayant un objectif d'appareil photographique **caractérisé en ce que**, en utilisation, les centres de la lentille ophtalmique (106) et de l'objectif de l'appareil photographique (108) sont alignés afin de former un axe d'alignement (X) et où le au moins un moyen d'éclairage (104) est capable d'effectuer un mouvement linéaire le long d'un axe radial (A-E) de l'objectif de l'appareil photographique (108) et un mouvement de pivotement autour du plan radial (A'-E') incorporant un axe radial et un axe d'alignement, de sorte que le cercle de la lumière émise par le au moins un moyen d'éclairage (104) est constamment dirigé vers le centre de la lentille ophtalmique (106).
 10. Dispositif ophtalmique selon l'une quelconque des revendications précédentes, comportant en outre des moyens de sélection pour choisir parmi une pluralité de paramètres, chaque paramètre représentant une taille de pupille ou une plage de tailles de pupille, de sorte que, lorsque le paramètre est modifié, le au moins un moyen d'éclairage (104) se déplace de manière linéaire le long de son axe radial (A-E) vers la position spécifiée par le nouveau paramètre et pivote autour du plan radial (A'-E') jusqu'à ce que le cercle de lumière émis par le au moins un moyen d'éclairage soit dirigé sur le centre de la lentille ophtalmique.
 11. Dispositif ophtalmique selon l'une quelconque des revendications précédentes, dans lequel le mouvement linéaire et de pivotement du au moins un moyen d'éclairage (104) est commandé par une ou plusieurs commandes manuelles.
 12. Dispositif ophtalmique selon l'une quelconque des revendications 1 à 10, comportant en outre des moyens de mesure automatisés pour obtenir une mesure de la taille de la pupille à examiner, les moyens de mesure automatisés commandant également le mouvement linéaire et de pivotement du au moins un moyen d'éclairage (104) à une position déterminée comme étant optimale pour la taille de pupille mesurée.
 13. Dispositif ophtalmique selon l'une quelconque des revendications précédentes, comportant en outre au moins une lentille de grossissement, chaque lentille de grossissement étant associée à au moins une position linéaire du au moins un moyen d'éclairage (104), de sorte que la position linéaire du au moins un moyen d'éclairage détermine les lentilles de grossissement qui sont positionnées dans l'axe d'alignement (X).
 14. Dispositif ophtalmique selon l'une quelconque des revendications précédentes, dans lequel l'un des au moins un moyen d'éclairage (104) a une longueur d'onde comprise dans la plage de 450 à 490 nm.
 15. Dispositif ophtalmique selon la revendication 14, dans lequel les moyens d'éclairage (104) ont une longueur d'onde de 490 nm.
 16. Dispositif ophtalmique selon l'une quelconque des revendications précédentes, dans lequel l'un d'au moins un moyen d'éclairage (104) a une longueur d'onde comprise dans la plage de 491 à 559 nm.

17. Dispositif ophtalmique selon la revendication 16, dans lequel les moyens d'éclairage (104) ont une longueur d'onde de 540 nm.
18. Dispositif ophtalmique selon l'une quelconque des revendications précédentes, dans lequel l'un d'au moins un moyen d'éclairage (104) a une longueur d'onde comprise dans la plage de 560 à 595 nm.
19. Dispositif ophtalmique selon la revendication 18, dans lequel les moyens d'éclairage (104) ont une longueur d'onde de 590 nm.
20. Dispositif ophtalmique selon l'une quelconque des revendications précédentes, dans lequel l'un du au moins un moyen d'éclairage (104) a une longueur d'onde comprise dans la plage de 596 à 699 nm.
21. Dispositif ophtalmique selon la revendication 20, dans lequel les moyens d'éclairage (104) ont une longueur d'onde de 630 nm.
22. Dispositif ophtalmique selon l'une quelconque des revendications précédentes, dans lequel l'un du au moins un moyen d'éclairage (104) a une longueur d'onde de 700 nm.
23. Dispositif ophtalmique selon l'une quelconque des revendications précédentes, dans lequel l'un du au moins un moyen d'éclairage (104) produit une lumière blanche.
24. Dispositif ophtalmique selon l'une quelconque des revendications précédentes, dans lequel l'un du au moins un moyen d'éclairage (104), ou un sous ensemble du au moins un moyen d'éclairage, est éclairé conformément à une séquence prédéterminée.
25. Dispositif ophtalmique selon l'une quelconque des revendications précédentes incluant au moins un moyen d'interface (212) en vue d'une connexion à au moins l'un des éléments suivants : un ordinateur externe, un moniteur externe, un spectromètre externe.
26. Dispositif ophtalmique selon l'une quelconque des revendications précédentes, comportant en outre un spectromètre, le spectromètre étant opérationnel pour produire un graphique spectrométrique d'images prises par l'appareil photographique.
27. Dispositif ophtalmique selon l'une quelconque des revendications précédentes, dans lequel le au moins un moyen d'éclairage (104) est d'intensité variable.
28. Dispositif ophtalmique selon la revendication 27, dans lequel le niveau d'intensité du au moins un moyen d'éclairage (104) est fonction d'un paramètre de couleur de pupille du dispositif ophtalmique.
29. Dispositif ophtalmique selon l'une quelconque des revendications précédentes, dans lequel le moyen d'éclairage (104) sont des diodes d'émission de lumière à l'état solide.
30. Dispositif ophtalmique selon l'une quelconque des revendications 1 à 28, dans lequel les moyens d'éclairage (104) comportent des ampoules et des moyens de focalisation de lumière.
31. Dispositif ophtalmique selon l'une quelconque des revendications précédentes, dans lequel la lentille ophtalmique (106) est comprise dans une plage de 20 40 dioptries.
32. Dispositif ophtalmique selon la revendication 31, dans lequel la lentille ophtalmique (106) est de 20 dioptries.
33. Dispositif ophtalmique selon l'une quelconque des revendications précédentes, comportant en outre des moyens de focalisation.
34. Dispositif ophtalmique selon la revendication 33, dans lequel les moyens de focalisation prennent la forme de moyens de déplacement opérationnels pour déplacer la lentille ophtalmique (106) de manière linéaire le long de l'axe d'alignement (X).
35. Structure portable (400) ayant au moins un dispositif ophtalmique selon la revendication 1, et selon l'une quelconque des revendications 9 à 34 lorsqu'elles sont dépendantes de la revendication 1, fixé sur celle-ci.
36. Structure portable (400) ayant au moins un dispositif ophtalmique selon la revendication 1, et l'une quelconque des revendications 9 et 11 à 34 lorsqu'elles sont dépendantes de la revendication 1, monté par coulissement sur celle-ci.
37. Procédé de détermination d'un niveau de glucose d'un patient en utilisant le dispositif ophtalmique selon l'une quelconque des revendications 1 à 34, comportant les étapes consistant à : émettre un faisceau de lumière ayant une longueur d'onde comprise dans la plage de 570 à 590 nm dans une pupille du patient ; prendre une photo de la pupille en utilisant un appareil photographique (102) ayant une lentille ophtalmique associée (106) d'un grossissement d'au moins 20x ; et déterminer le niveau de glucose du patient à partir du niveau sanguin dans les veines du disque optique.
38. Procédé de détermination d'un niveau d'hémoglobine d'un patient en utilisant le dispositif ophtalmique

selon l'une quelconque des revendications 1 à 34, comportant les étapes consistant à :

émettre un faisceau de lumière ayant une longueur d'onde comprise dans la plage de 570 à 590 nm dans une pupille du patient ; prendre une image de la pupille en utilisant un appareil photographique (102) ayant une lentille ophtalmique associée (106) d'un grossissement d'au moins 20x ; et déterminer le niveau d'hémoglobine du patient à partir de l'image de la macula.

5

10

15

20

25

30

35

40

45

50

55

Fig 1. Colour light ring for retina imaging

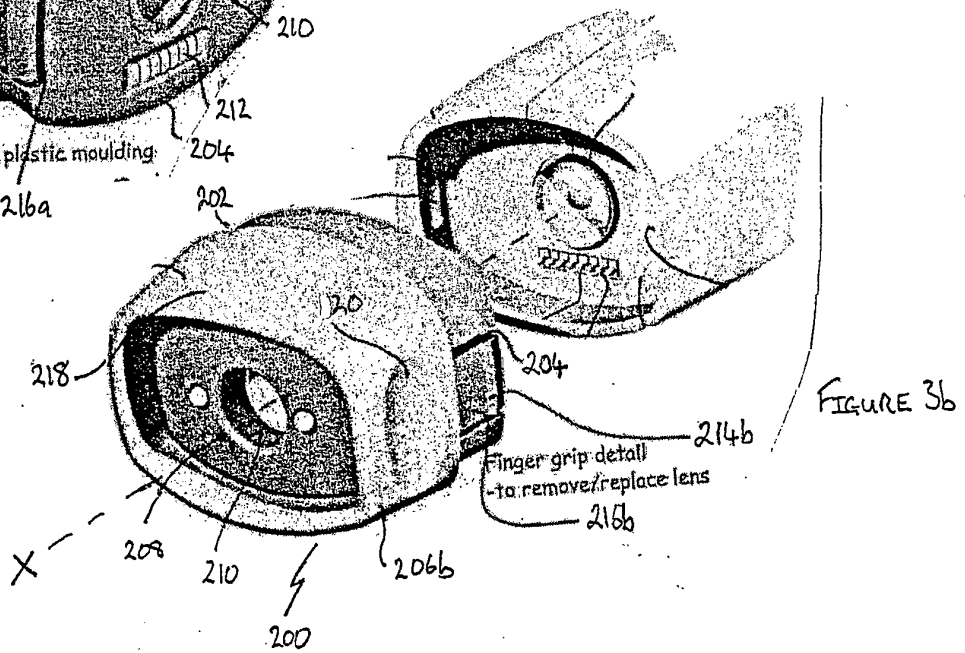
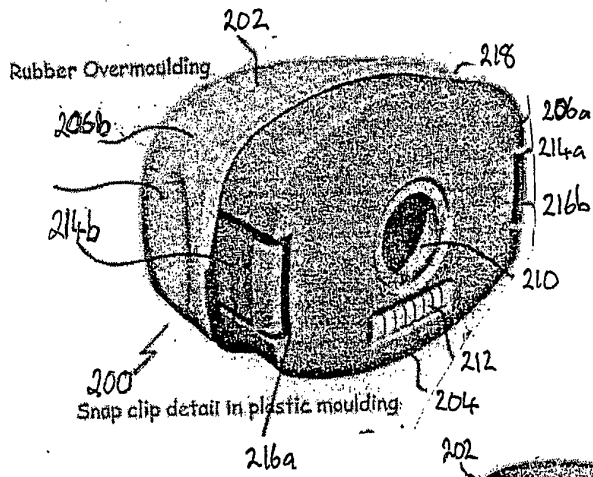
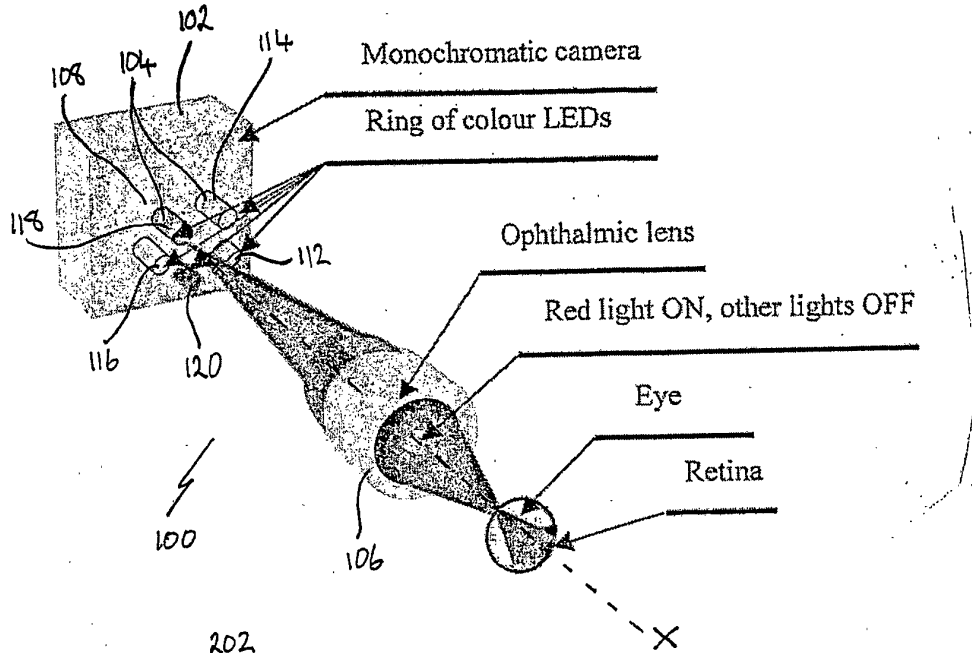

FIGURE 2

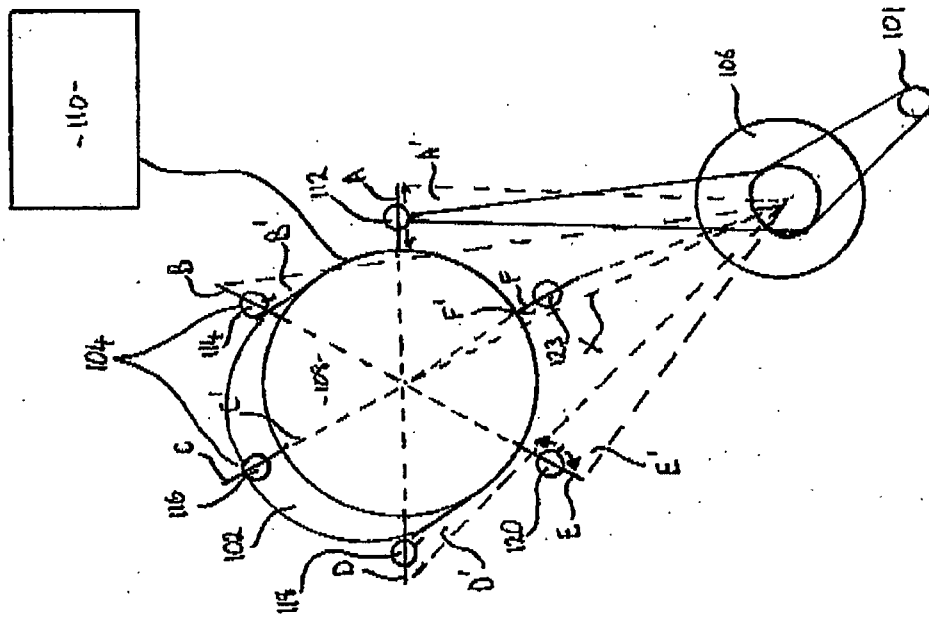

FIG. 4
FUNDUS CAMERA BLOCK DIAGRAM WITH
MONOCHROMATIC COLOUR LIGHT EMITTING
DIODES

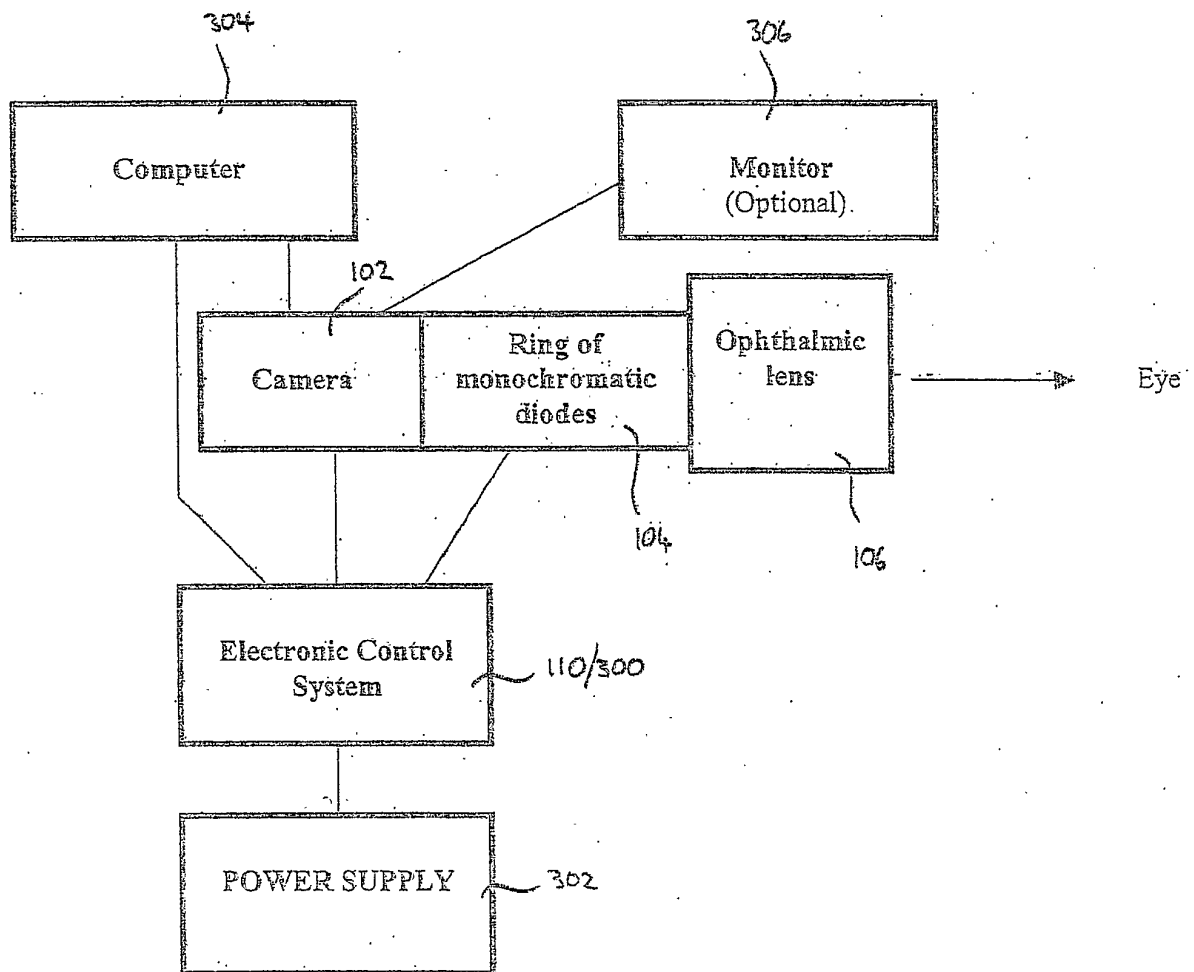
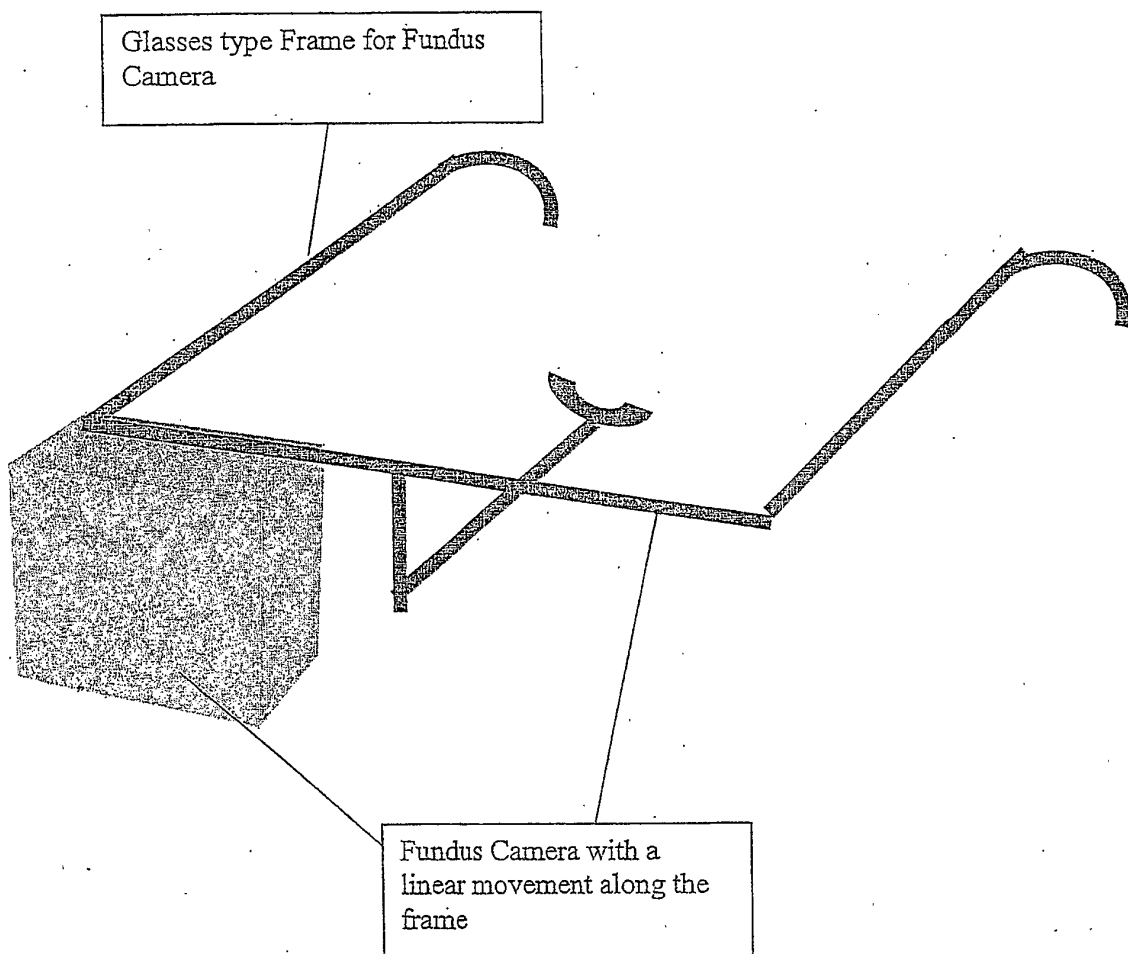

FIG. 5
GLASSES TYPE FUNDUS CAMERA FOR DIABETIC
RETINOPATHY AND ANEURYSMS DIAGNOSIS



REFERENCES CITED IN THE DESCRIPTION

This list of references cited by the applicant is for the reader's convenience only. It does not form part of the European patent document. Even though great care has been taken in compiling the references, errors or omissions cannot be excluded and the EPO disclaims all liability in this regard.

Patent documents cited in the description

- US 20030011757 A [0005]

专利名称(译)	眼科照相机，眼科照相机适配器和用于确定患者的血红蛋白和葡萄糖水平的方法		
公开(公告)号	EP1641384A4	公开(公告)日	2007-11-21
申请号	EP2004737431	申请日	2004-06-18
申请(专利权)人(译)	狮子会眼科学院有限公司		
当前申请(专利权)人(译)	狮子会眼科学院有限公司		
[标]发明人	YOGESAN KANAGASINGAM SUPLEWSKI GABRIEL SPARK MATTHEW DAVID CONSTABLE IAN		
发明人	YOGESAN, KANAGASINGAM SUPLEWSKI, GABRIEL SPARK, MATTHEW, DAVID CONSTABLE, IAN		
IPC分类号	A61B3/12 A61B5/00		
CPC分类号	A61B3/12 A61B5/14532 A61B5/1455		
优先权	2003903157 2003-06-20 AU		
其他公开文献	EP1641384A1 EP1641384B1		
外部链接	Espacenet		

摘要(译)

本发明提供一种眼科照相机，其包括：具有照相机镜头的照相机；以及具有所述照相机镜头的照相机。至少一个照明装置；和眼镜片。眼科镜片和照相机镜片的中心对准以形成对准轴。至少一个照明装置能够沿着摄像机镜头的径向轴线线性运动，并且能够绕着包含径向轴线和对准轴线的径向平面枢转运动。以这种方式，由至少一个照明装置发射的光的圆始终被引导到眼科镜片的中心。