



(11) **EP 1 593 214 B1**

(12) **EUROPEAN PATENT SPECIFICATION**

(45) Date of publication and mention of the grant of the patent:  
**31.08.2011 Bulletin 2011/35**

(51) Int Cl.:  
**H04B 13/00** <sup>(2006.01)</sup> **A61B 5/00** <sup>(2006.01)</sup>  
**A61B 5/07** <sup>(2006.01)</sup> **A61B 1/05** <sup>(2006.01)</sup>

(21) Application number: **03781095.9**

(86) International application number:  
**PCT/KR2003/002937**

(22) Date of filing: **31.12.2003**

(87) International publication number:  
**WO 2004/068748 (12.08.2004 Gazette 2004/33)**

(54) **METHOD AND SYSTEM FOR DATA COMMUNICATION IN HUMAN BODY AND SENSOR THEREFOR**

VERFAHREN UND SYSTEM ZUR DATENKOMMUNIKATION IN EINEM MENSCHLICHEN KÖRPER UND SENSOR DAFÜR

PROCEDE ET SYSTEME DE COMMUNICATION DE DONNEES DANS UN CORPS HUMAIN ET CAPTEUR ASSOCIE

(84) Designated Contracting States:  
**AT BE BG CH CY CZ DE DK EE ES FI FR GB GR HU IE IT LI LU MC NL PT RO SE SI SK TR**

• **KIM, Young-Rok**  
**302-170 Daejeon (KR)**

(30) Priority: **25.01.2003 KR 2003005059**

(74) Representative: **Hill, Christopher Michael et al**  
**Page White & Farrer**  
**Bedford House**  
**John Street**  
**London, WC1N 2BF (GB)**

(43) Date of publication of application:  
**09.11.2005 Bulletin 2005/45**

(73) Proprietor: **Korea Institute of Science and Technology**  
**Seoul 136-791 (KR)**

(56) References cited:  
**EP-A- 0 667 115** **KR-A- 99 008 428**  
**KR-A- 2003 039 759** **KR-B- 272 700**  
**US-A- 5 833 603** **US-A1- 2002 138 009**  
**US-A1- 2003 092 973**

(72) Inventors:

- **KIM, Tae-Song**  
**121-711 Seoul (KR)**
- **PARK, Jong-Oh**  
**137-798 Seoul (KR)**
- **KIM, Byung-Kyu**  
**136-791 Seoul (KR)**
- **KIM, Jin-Seok**  
**Dobong-Gu,**  
**132-791 Seoul (KR)**
- **CHEUNG, Han**  
**Jijok-Dong,**  
**Yuseong-Gu,**  
**306-769 Daejeon (KR)**
- **CHO, Won-Woo**  
**305-335 Daejeon (KR)**
- **YOON, Nan-Young**  
**Yuseong-Gu,**  
**305-707 Daejeon (KR)**

- **BASKIYAR S: "A real-time fault tolerant intra-body network" LOCAL COMPUTER NETWORKS, 2002. PROCEEDINGS. LCN 2002. 27TH ANNUAL IEEE CONFERENCE ON 6-8 NOV.2002, PISCATAWAY, NJ, USA,IEEE, 6 November 2002 (2002-11-06), pages 235-240, XP010628172 ISBN: 0-7695-1591-6**
- **HACHISUKA K ET AL: "Development and performance analysis of an intra-body communication device" TRANSDUCERS, SOLID-STATE SENSORS, ACTUATORS AND MICROSYSTEMS, 12TH INTERNATIONAL CONFERENCE ON, 2003, PISCATAWAY, NJ, USA,IEEE, vol. 2, 9 June 2003 (2003-06-09), pages 1722-1725, XP010647499 ISBN: 0-7803-7731-1**

Note: Within nine months of the publication of the mention of the grant of the European patent in the European Patent Bulletin, any person may give notice to the European Patent Office of opposition to that patent, in accordance with the Implementing Regulations. Notice of opposition shall not be deemed to have been filed until the opposition fee has been paid. (Art. 99(1) European Patent Convention).

**EP 1 593 214 B1**

- **WILFRIED MOKWA ET AL: "Micro-Transponder Systems for Medical Applications" IEEE TRANSACTIONS ON INSTRUMENTATION AND MEASUREMENT, IEEE SERVICE CENTER, PISCATAWAY, NJ, US, vol. 50, no. 6, December 2001 (2001-12), XP011025449 ISSN: 0018-9456**

**Description****TECHNICAL FIELD**

**[0001]** The present invention relates to a method and system for transmitting data from a sensor put in the human body to the outside of the human body to collect various medical information, and particularly to a method and system for data communication in human body, wherein a current generated from the sensor flows through the human body as a conductor to transmit data to the outside of the human body.

**BACKGROUND ART**

**[0002]** Various sensors for collecting medical information in the human body have been developed and used, herein, not only a technique for collecting information in the human body but also a technique for transmitting collected information to the outside of the human body are very important.

**[0003]** In general data transmitting methods, there is a communication cable method applied to an endoscope which is developed for observing the stomach and intestines. In the communication cable method, a cable made of a conducting wire or an optic fiber is inserted into the human body through throat of the patient. The communication cable method has high reliability and high data quality, however, it may cause severe pain to the patient.

**[0004]** In order to solve the above-mentioned problem, Given Imaging LTD, In Israel has developed a capsule type endoscope called M2A. When a patient swallows the capsule type endoscope like a tablet, video data in the human body photographed by a camera of the endoscope are transmitted to an external-receiving unit, and displayed in a monitor.

**[0005]** However, in the capsule type endoscope, since radio wave is used to transmit a signals, power consumption is large, so that operation time is short, and receiving sensitivity is deteriorated due to interference of various electric waves from the outside of the human body. In addition, radio-transmitting apparatus such as a converter circuit for converting a video signal into a high frequency signal and an antenna for signal transmission, etc. are required, so that volume is increased and production cost is increased. Also, high frequency may be harmful to the human body.

**[0006]** US Patent Publication No. 2002/0138009 discloses an implantable sensor device, such as a pressure monitor, using wireless communication techniques including "intracorporeal conductive communication or "personal area networks".

**[0007]** Sangeev Baskiyar, proceedings of the 27th Arrival IEEE Conference on Local Compute Networks, "A Real-time Fault Tolerant Intra-Body Network", discloses intra-body communication networks relying on Personal Area Networks.

**[0008]** Wilfred Mokwa and Uwe Schnakenberg, IEEE

Translations on Instrumentation and Measurement, Vol. 50, No. 6, December 2001, "Micro-Transponder Systems for Medical Applications", discloses a low power CMOS electronics system implantable in the human body which transmits data using an RF field.

**[0009]** EP-A-0667115 discloses a swallowable capsule and system capable of transmitting data using a RF signal.

**[0010]** GB 2308481 discloses a device for body-linked data transmission between two terminals has a first terminal 21 which can be worn on a body 22 of a living being and has an interface comprising a first pair of electrodes 6, 7, arranged at points which are spaced apart from one another on the body, for inputting data signals into the body and/or for outputting the same from the body, and a second terminal 27 which has a touch-sensitive interface with a second pair of touch-sensitive electrodes 16, 17 which can be touched by two fingers of the body 22 via which data signals which are input into the body are output from the same and/or data signals are input into the body.

**[0011]** JP 60250731 discloses a living body communication system wherein 2 electrodes are arranged on calf muscles and are connected to a carrier signal detecting amplifier through an analog switch, and its output is inputted to a frequency discriminator. Thus, the information transmitted with the carrier is detected and transmitted through the living body tissue so that the complication of wiring and radio interference are removed.

**[0012]** EP 0109184 discloses a personnel identification system for controlling access to restricted equipment or restricted areas comprises a portable device such as a wrist watch (10) in which a unique digital identification code is stored, and a static control unit having a conductive touch element (12) and a code signal receiver (14) for comparing the identification code with a stored access code.

**TECHNICAL GIST OF THE PRESENT INVENTION**

**[0013]** In order to solve the above-described problems, it is an object of the present invention to provide a method and system for data communication in the human body for flowing a current generated from the sensor through the human body to transmit data to the outside of the human body. In addition, it is another object of the present invention to provide a sensor having a transmitting electrode capable of generating a current in the human body to flow a current through the human body to transmit data to the outside of the human body.

**[0014]** In order to achieve the above-mentioned objects, in a method for transmitting a signal from a sensor put in the human body to the outside of the human body, a method for data communication in the human body in accordance with the present invention includes the steps of generating electric potential difference between transmitting electrodes installed on the surface of the sensor; supplying a current from the transmitting electrode hav-

ing higher electric potential to the inside of the human body to flow the current through the surface of the human body back into the inside of the human body and sinking the current to the transmitting electrode having lower electric potential; and inducing a voltage between receiving electrodes installed on the surface of the human body by the current flowing through the surface of the human body.

**[0015]** In addition, a system for data communication in the human body in accordance with the present invention includes a sensor, which is put in the human body, having transmitting electrodes for generating electric potential difference; and a receiver installed on the surface of the human body for receiving a current generated by the electric potential difference through the human body.

**[0016]** In addition, a sensor in accordance with the present invention includes a lighting device for irradiating the inside of the human body; a lens for focusing light incident from the inside of the human body; a CMOS image sensor for generating an electric signal from the light focused by the lens; a housing for containing the lighting device, the lens and the CMOS image sensor; and a transmitting electrode installed on the surface of the housing to receive the electric signal.

**[0017]** Accordingly, the present invention provides a method of data communication for transmitting a signal from a sensor in the human body to the outside of the human body, the method comprising the steps of generating electric potential difference in the form of a digital signal between transmitting electrodes installed on the surface of a sensor; controlling the transmitting electrodes according to information to be transmitted, so that a plus is represented as a first state when the first transmitting electrode has a higher electric potential and the second transmitting electrode has a lower electric potential, and a negative is represented as a second state when the first transmitting electrode has a lower electric potential and the second transmitting electrode has a higher electric potential; supplying a conduction current from the transmitting electrode having higher electric potential to the inside of the human body so that the conduction current flows in the form of a digital signal through the surface of the human body back into the inside of the human body and sinks to the transmitting electrode having lower electric potential; and inducing a voltage in the form of a digital signal between receiving electrodes installed on the surface of the human body by the conduction current flowing through the surface of the human body.

**[0018]** The present invention also provides a system for transmitting a signal from a sensor put in the human body to the outside of the human body, comprising a sensor, having transmitting electrodes for generating electric potential difference in a form of a digital signal therebetween, and a switcher for switching the transmitting electrodes according to information to be transmitted so that a plus is represented as a first state when the first transmitting electrode has a higher electric potential and

the second transmitting electrode has a lower electric potential, and a negative is represented as a second state when the first transmitting electrode has a lower electric potential and the second transmitting electrode has a higher electric potential, and for supplying a conduction current from the transmitting electrode having higher electric potential to the inside of the human body to flow the conduction current in the form of a digital signal through the surface of the human body back into the inside of the human body and to sink the conduction current to the transmitting electrode having lower electric potential; and a receiver suitable for installing on the surface of the human body to induce a voltage in form of a digital signal between receiving electrodes of the receiver from the conduction current generated by the electric potential difference.

**[0019]** The present invention also provides a capsule type endoscope put in the human body, comprising a lighting device for irradiating the inside of the human body; a lens for focusing light incident from the inside of the human body; a CMOS image sensor for capturing and processing a video signal from the light focused by the lens to generate an electric signal according to the video signal; a housing for containing the lighting device, the lens and the CMOS image sensor; transmitting electrodes installed on the surface of the housing for receiving the electric signal, for generating electric potential difference in form of a digital signal between the transmitting electrodes according to the electric signal; and a switcher for switching the transmitting electrodes according to information to be transmitted so that a plus is represented as a first state when the first transmitting electrode has a higher electric potential and the second transmitting electrode has a lower electric potential, and a negative is represented as a second state when the first transmitting electrode has a lower electric potential and the second transmitting electrode has a higher electric potential, and for supplying a conduction current from the transmitting electrode having higher electric potential to the inside of the human body to flow the conduction current in form of a digital signal through the surface of the human body back into the inside of the human body and to sink the conduction current to the transmitting electrode having lower electric potential.

#### **BRIEF DESCRIPTION OF DRAWINGS**

**[0020]** The accompanying drawings, which are included to provide a further understanding of the invention and are incorporated in and constitute a part of this specification, illustrate embodiments of the invention and together with the description serve to explain the principles of the invention.

**[0021]** In the drawings:

Figure 1 is an exemplary view illustrating a method for data communication in the human body in accordance with the present invention;

Figure 2 are perspective views illustrating several embodiments of a transmitting electrode installed to the surface of a sensor used in a system for data communication in the human body in accordance with the present invention:

Figure 3 is a sectional view illustrating the sensor of the system for data communication in the human body in accordance with the present invention; and Figure 4 is a circuit diagram illustrating an internal construction of a CMOS image sensor of the sensor.

## DETAILED DESCRIPTION OF THE INVENTION

**[0022]** Hereinafter, the preferred embodiment of the present invention will be described with reference to accompanying drawings.

**[0023]** Figure 1 is an exemplary view illustrating a method and a system for data communication in the human body in accordance with the present invention. As depicted in Figure 1, a sensor 10 placed inside the human body 1, for example, in the digestive organs transmits information of the inside of the human body 1 to a receiver 20 installed on the surface of the human body through the human body 2.

**[0024]** With reference to Figure 1, in the system for data communication in the human body in accordance with the present invention, a method for data communication in the human body capable of transmitting a signal from the sensor 10 inside the human body 1 to the receiver 20 placed in the outside of the human body will be described in more detail. Various information (for example, pictures of the inside of the body, PH, temperature or electric impedance, etc.) collected by the sensor 10 is converted into an electric signal by a signal processing circuit of the sensor and is applied to a transmitting electrode 11 through an output line of the signal processing circuit, and accordingly electric potential difference occurs between the two transmitting electrodes 11. Because the transmitting electrode 11 is contacted to the inside of the human body 1 (it is electrically connected with the human body through body fluids in the digestive organs), by electric potential difference between the two transmitting electrodes 11, a current 3 flows through the human body 2. The current 3 flows from the transmitting electrode having higher electric potential through the surface of the human body back into the inside of the human body 1 and is sunken to the transmitting electrode having lower electric potential. Herein, the current flowing through the surface of the human body induces a voltage between two receiving electrodes 21, a signal transmitted from the sensor 10 put in the human body 1 can be sensed by the receiver 20 outside of the human body. The receiver 20 restores a video signal by processing the received signal, displays it on a monitor or stores it in a memory.

**[0025]** Figure 2 illustrate several embodiments of the transmitting electrode 11 installed on the surface of the sensor 10 of the system for data communication in the

human body in accordance with the present invention. On the surface of the sensor 10, two metal plates, namely, two transmitting electrodes are formed, which are respectively connected to outlines of a signal processing circuit of the sensor.

**[0026]** If the two transmitting electrodes are electrically isolated and separated from each other sufficiently, the transmitting electrodes can be formed at any position of the surface of the sensor. Herein, it is preferable that the transmitting electrodes have a sensor-covering shape, namely, a three-dimensionally curved shape in order to be contacted with the inside of the human body easily.

**[0027]** In Figure 2, (a) shows a structure of the transmitting electrode of sensor shown in Figure 1. The transmitting electrode consists of a first electrode and a second electrode respectively surrounding the both ends of the sensor. A transmitting electrode shown in (b) consists of a first electrode surrounding an end of the sensor and a second electrode covering the other end of the sensor as a band shape. A transmitting electrode shown in (c) consists of a first electrode and a second electrode respectively covering both ends of the sensor as a band shape. In addition, a transmitting electrode shown in (d) consists of a first electrode and a second electrode symmetrically formed along a longer axis of the sensor.

**[0028]** Because the transmitting electrode is exposed to the inside of the human body, it has to be made of metal having good resistance against corrosion by a reactive material such as a digestive fluid, etc. and also harmless to the human body. In the embodiments of the present invention, as metal having good corrosion resistance and harmless to the human body, SUS316L or gold is used. In addition, in order to isolate the transmitting electrodes formed on the surface of the sensor electrically, the surface of the sensor has to be a nonconductor harmless to the human body. As a nonconductor harmless to the human body, peek, polyethylene or polypropylene in a plastic group may be used. In order to improve harmlessness to the human body, parylene may be coated onto the surface of the sensor made of peek, polyethylene or polypropylene.

**[0029]** Figure 3 is a sectional view illustrating an internal structure of a capsule type endoscope as a sensor used for the system in accordance with the present invention. As depicted in Figure 3, the capsule type endoscope has a diameter of 10mm and a length of 20mm. A light receiving window 17 of dome shape is formed in an end of a housing forming an external shape of the capsule type endoscope, and a rectangular container 18 is formed in the other end of the housing. Accordingly, the capsule type endoscope has a bullet shape.

**[0030]** In the capsule type endoscope, the light receiving window 17 which is a part for passing light is made of a nonconductor harmless to the human body and passing light. The container 18 that is a part for containing several devices also is made of a nonconductor harmless to the human body. The light receiving window 17 and the container 18 are sealed so that infiltration of a diges-

tive fluid, etc. into the capsule type endoscope may be prevented and also leakage of substances in the capsule type endoscope into the human body may be avoided.

**[0031]** As depicted in Figure 3, the capsule type endoscope has the external shape of the housing consisting of the light receiving window 17 and the container 18. The container 18 includes a lighting device 12, a lens 13, a CMOS image sensor 14 and a battery 15 and a transmitting electrode 11 electrically isolated-formed on the surface of the container 18.

**[0032]** First, the lens 13 is arranged behind the light receiving window 17, and the CMOS image sensor 14 in which various circuits are integrated is arranged behind the lens 13. A distance between the lens 13 and the CMOS image sensor 14 is adjusted so as to focus light incident through the light receiving window 17 on the surface of the CMOS image sensor 14. Around the lens 13 and the CMOS image sensor 14, plural lighting devices 12 are arranged as donut-shape. In the embodiment of the present invention, four LEDs are used for the lighting devices 12. Non-reflection coating is performed on the inner and outer surfaces of the light receiving window 17 so that light irradiated from the lighting device 12 may pass through the light receiving window 17 smoothly and illuminate an object. A battery 15 as power supply is arranged behind the CMOS image sensor 14. In the embodiment of the present invention, a silver oxide battery having an even discharge voltage and causing little harm to the human body is used as the battery 15.

**[0033]** The operation of the capsule type endoscope will be described. While the lighting devices 12 irradiate a light, the CMOS image sensor 14 captures an image of the object through the lens 13. The CMOS image sensor 14 processes the captured video signal through various internal circuits and applies the signal to the transmitting electrodes respectively connected to the two output lines 16, and accordingly the receiving electrode placed in the outside of the human body can sense the signal, as described above.

**[0034]** Figure 4 is a circuit diagram illustrating the CMOS image sensor 14 in order to describe the operation principles of the capsule type endoscope in more detail.

**[0035]** As depicted in Figure 4, the CMOS image sensor 14 includes a pixel array 100 for capturing and storing a video signal; a read circuit 110 for fetching a signal of each pixel sequentially; a coding circuit 120 for coding an output signal of the read circuit 110; a switching circuit 130 for transmitting a signal coded in the coding circuit 120 through the two output lines; a current limiting circuit 140 for adjusting a current value so as to prevent flowing of a current causing damage to the human body; a control circuit 150 for controlling the signal processing and the operation of the lighting device 12; and an oscillating circuit 160 for determining an operational frequency.

**[0036]** In the embodiment of the present invention, the pixel array 100 (of 320 x 240 pixels) can capture and store video signals of high resolution. The read circuit 110 processes the stored video signals sequentially as

a frame or more per 1 sec, and accordingly there is no need to have a memory disadvantageous in the cost and volume aspects. In addition, the control circuit 150 determines brightness inside the human body based on brightness of light incident to the pixel array 100 and controls the lighting device 12 to operate variably for 5 ~ 200msec. The video signals are captured by the pixel array 100 during that time. According to that, each video frame is instantly captured, and brightness thereof is better. And a PSK method that is simple and has strong tolerance against noise is used in encoding.

**[0037]** When the signal transmitted from the coding circuit 120 is "1", the switching circuit 130 applies + voltage to the first output line 16a and grounds the second output line 16b. When the signal transmitted from the coding circuit 120 is "0", the switching circuit 130 grounds the first output line 16a and applies a + voltage to the second output line 16b. As described-above, since the present invention transmits a signal using not the voltage size but the voltage polarity, it can be stronger to noise.

**[0038]** The current limiting circuit 140 serves to prevent a current more than 5mA from flowing through the human body. In the embodiment of the present invention, the current limiting circuit 140 is implemented by serially connecting resistors to the two output lines 16 of the switching circuit 130 respectively. For example, assume that when a power voltage is 3 V the current limiting circuit 140 comprises resistors of 300 ohms serially connected to the two output lines respectively. In this case, although the transmitting electrode has a substantial short circuit because of very small resistance of the human body, current flowing through the human body does not exceed 5mA. In addition, by connecting a capacitor to each resistance in parallel, it is possible to remove a high frequency component of the signal transmitted to the human body and perform electric matching with the human body, so that signal-transmitting performance can be improved.

**[0039]** The signal passing the current limiting circuit 140 is applied to the two transmitting electrodes 11 and is transmitted to the outside of the human body through the human body. In the conventional frequency communication method, a high frequency signal of several hundred MHz is required, however, in the present invention, a video signal captured by the capsule type endoscope can be transmitted to the outside of the human body with a low frequency signal of 10MHz.

#### **INDUSTRIAL APPLICABILITY**

**[0040]** Since the present invention uses a low frequency and current instead of a high frequency through antenna when communicating with sensor in the human body, it reduces power consumption and attenuation in human body, has no effect on external interference and cause no damage to the human body. In addition, since the invention transmits a signal using voltage polarity, it is strong to noise, and accordingly receiving sensitivity is superior.

**[0041]** In addition, the sensor in accordance with the present invention does not need a radio transmitter and antenna, and also does not need an additional memory because it processes video signals sequentially along the passage of time, so that a small-sized and low-priced capsule type endoscope can be provided.

### Claims

1. A method of data communication for transmitting a signal from a sensor in the human body to the outside of the human body, the method comprising the steps of:

generating electric potential difference in the form of a digital signal between transmitting electrodes (11) installed on the surface of a sensor (10);

controlling the transmitting electrodes (11) according to information to be transmitted, so that a plus is represented as a first state when the first transmitting electrode (11) has a higher electric potential and the second transmitting electrode (11) has a lower electric potential, and a negative is represented as a second state when the first transmitting electrode (11) has a lower electric potential and the second transmitting electrode (11) has a higher electric potential; supplying a conduction current from the transmitting electrode (11) having higher electric potential to the inside of the human body (1) so that the conduction current (3) flows in the form of a digital signal through the surface of the human body (1) back into the inside of the human body (1) and sinks to the transmitting electrode (11) having lower electric potential; and inducing a voltage in the form of a digital signal between receiving electrodes (21) installed on the surface of the human body by the conduction current (3) flowing through the surface of the human body (1).

2. The method of claim 1, wherein the electric potential difference is generated by applying an electric signal of the sensor to the transmitting electrodes.
3. A method according to claim 1 or claim 2, wherein the sensor is situated in a capsule type endoscope and the method comprises generating electric potential difference between transmitting electrodes installed on the surface of the capsule type endoscope.
4. The method of claim 3, wherein the capsule type endoscope makes a conduction current flow from one transmitting electrode to the other transmitting electrode when a signal to be transmitted is one state of a digital signal "1" or "0" and makes a current flow

from the other transmitting electrode to one transmitting electrode when a signal to be transmitted is the other alternative of a digital signal "1" or "0".

5. The method of claim 3, wherein an amount of the current is limited by connecting resistance serially to the transmitting electrode respectively.
6. The method of claim 5, wherein a capacitor is connected to each resistance in parallel.
7. A system for data communication in the human body (1) for transmitting a signal from a sensor (10) put in the human body (1) to the outside of the human body, comprising:

a sensor (10), having transmitting electrodes (11) for generating electric potential difference in the form of a digital signal therebetween, and a switcher (130) for switching the transmitting electrodes (11) according to information to be transmitted so that a plus is represented as a first state when the first transmitting electrode (11) has a higher electric potential and the second transmitting electrode has a lower electric potential, and a negative is represented as a second state when the first transmitting electrode (11) has a lower electric potential and the second transmitting electrode has a higher electric potential, and for supplying a conduction current (3) from the transmitting electrode (11) having higher electric potential to the inside of the human body to flow the conduction current in the form of a digital signal through the surface of the human body back into the inside of the human body and to sink the conduction current to the transmitting electrode (11) having lower electric potential; and a receiver suitable for installing on the surface of the human body (1) to induce a voltage in form of a digital signal between receiving electrodes of the receiver (20) from the conduction current (3) generated by the electric potential difference.

8. The system of claim 7, wherein the transmitting electrodes (11) are installed on the surface of the sensor (10) to be electrically isolated.
9. The system of claim 7 or claim 8, wherein the transmitting electrodes (11) are electrically connected with an internal circuit of the sensor (10) to receive an electric signal generated from the internal circuit.
10. The system of claim 8, wherein the transmitting electrodes (11) are three-dimensionally formed.
11. The system of any of claims 7 to 10, wherein the transmitting electrodes (11) include a first electrode

and a second electrode which surround both ends of the sensor (10).

12. The system of any of claims 7 to 10, wherein the transmitting electrodes (11) include a first electrode surrounding an end of the sensor (10) and a second electrode covering the other end of the sensor (10) as a band shape. 5
13. The system of any of claims 7 to 10, wherein the transmitting electrodes (11) include a first electrode and a second electrode respectively covering both ends of the sensor (10) as a band shape. 10
14. The system of any of claims 7 to 10, wherein the transmitting electrodes (11) include a first electrode and a second electrode symmetrically formed along a longer axis of the sensor (10). 15
15. The system of any of claims 7 to 14, wherein the isolator for isolating of the transmitting electrodes (11) (the surface of the sensor (10)) is made of one of peek, polyethylene and polypropylene. 20
16. The system of any of claims 7 to 15, wherein the isolator for isolating of the transmitting electrodes (11) (the surface of the sensor (10)) is coated with Parylene. 25
17. The system of any of claims 7 to 16, wherein the transmitting electrodes (11) are made of a conductive material harmless to the human body (1). 30
18. The system of claim 17, wherein the conductive material is SUS316L or gold. 35
19. A capsule type endoscope suitable for putting in the human body (1), comprising:
- a lighting device (12) for irradiating the inside of the human body (1); 40
  - a lens (13) for focusing light incident from the inside of the human body (1);
  - a CMOS image sensor (14) for capturing and processing a video signal from the light focused by the lens (13) to generate an electric signal according to the video signal; 45
  - a housing for containing the lighting device, the lens (13) and the CMOS image sensor (14);
  - transmitting electrodes (11) installed on the surface of the housing for receiving the electric signal, for generating electric potential difference in the form of a digital signal between the transmitting electrodes (11) according to the electric signal; and 50
  - a switcher (130) for switching the transmitting electrodes (11) according to information to be transmitted so that a plus is represented as a

first state when the first transmitting electrode (11) has a higher electric potential and the second transmitting electrode (11) has a lower electric potential, and a negative is represented as a second state when the first transmitting electrode (11) has a lower electric potential and the second transmitting electrode (11) has a higher electric potential, and for supplying a conduction current (3) from the transmitting electrode (11) having higher electric potential to the inside of the human body (1) to flow the conduction current (3) in the form of a digital signal through the surface of the human body (1) back into the inside of the human body and to sink the conduction current (3) to the transmitting electrode (11) having lower electric potential.

20. The capsule type endoscope of claim 19, wherein the transmitting electrodes (11) are connected to an output line of the CMOS image sensor (14) and are installed on the surface of the housing to be electrically isolated.
21. The capsule type endoscope of claim 19 or claim 20, wherein the transmitting electrodes (11) are three-dimensionally formed.
22. The capsule type endoscope of any of claims 19 to 21, wherein the transmitting electrodes (11) include a first electrode and a second electrode which surround both ends of the housing.
23. The capsule type endoscope of any of claims 19 to 21, wherein the transmitting electrodes (11) include a first electrode surrounding an end of the housing and a second electrode covering the other end of the housing as a band shape.
24. The capsule type endoscope of any of claims 19 to 21, wherein the transmitting electrodes (11) include a first electrode and a second electrode respectively covering both ends of the housing as a band shape.
25. The capsule type endoscope of any of claims 19 to 21, wherein the transmitting electrodes (11) include a first electrode and a second electrode symmetrically formed along a longer axis of the housing.
26. The capsule type endoscope of any of claims 19 to 25, wherein the surface of the housing is made of one of peek, polyethylene and polypropylene.
27. The capsule type endoscope of claim 26, wherein the isolator for isolating of the transmitting electrodes (11), that is, the surface of the sensor (10), is coated with Parylene.
28. The capsule type endoscope of any of claims 19 to

- 27, wherein the transmitting electrodes (11) are made of a conductive material harmless to the human body (1).
29. The capsule type endoscope of claim 28, wherein the conductive material is SUS316L or gold.
30. The capsule type endoscope of any of claims 19 to 29, wherein the front of the housing is formed as a dome-shaped light receiving window (17) and the rear of the housing is formed as a rectangular container (18).
31. The capsule type endoscope of claim 30, wherein the light receiving window (17) is made of a material harmless to the human body and passing light.
32. The capsule type endoscope of claim 30 or claim 31, wherein non-reflection coating is provided on the inner and outer surfaces of the light receiving window (17).
33. The capsule type endoscope of any of claims 19 to 32, wherein the lighting device (12) is an LED.
34. The capsule type endoscope of any of claims 19 to 33, wherein the LED has a variable operation time within 5ms-200ms.
35. The capsule type endoscope of claim 19, wherein the CMOS image sensor (14) includes:
- a pixel array (100) for capturing and storing the video signal;
  - a read circuit (110) for fetching a video signal from the pixel array (100) sequentially;
  - a coding circuit (120) for coding an output signal of the read circuit;
  - a switching circuit (130) for changing polarity of an output line connected to the transmitting electrodes according to the coded signal to generate the electrical signal;
  - a current limiting circuit (140) for restricting flowing of a current more than a certain value;
  - a control circuit (150) for controlling operation of the lighting device and operation of the CMOS image sensor; and
  - an oscillating circuit for generating a pulse.
36. The capsule type endoscope of claim 35, wherein the pixel array (100) is adapted to capture and store the video signal while the lighting device irradiates.
37. The capsule type endoscope of claim 35, wherein the read circuit (110) is adapted to fetch and process the electric signal sequentially while the lighting device is turned off.
38. The capsule type endoscope of claim 35, wherein the coding circuit (120) is adapted to perform PSK coding.
39. The capsule type endoscope of claim 35, wherein the switching circuit (130) is adapted to change polarity of the output line by making a current flow from the first electrode to the second electrode when the coded signal is "1" and making a current flow from the second electrode to the first electrode when the coded signal is "0".
40. The capsule type endoscope of claim 35, wherein the current limiting circuit (140) is adapted to maintain the current to be not greater than 5mA.
41. The capsule type endoscope of claim 35, wherein the current limiting circuit (140) is constructed by connecting resistance serially to output lines of the switching circuit respectively.
42. The capsule type endoscope of claim 41, wherein the current limiting circuit (140) further includes a capacitor respectively connected to the resistance in parallel.

#### Patentansprüche

1. Verfahren der Datenkommunikation zur Übertragung eines Signals von einem Sensor im menschlichen Körper nach außerhalb des menschlichen Körpers, wobei das Verfahren die Schritte aufweist:
- Erzeugen einer elektrischen Potenzialdifferenz in der Form eines digitalen Signals zwischen Übertragungselektroden (11), welche an der Oberfläche eines Sensors (10) installiert sind;
  - Steuern der Übertragungselektroden (11) gemäß zu übertragender Information, so dass ein Plus als ein erster Zustand dargestellt wird, wenn die erste Übertragungselektrode (11) ein höheres elektrisches Potenzial und die zweite Übertragungselektrode (11) ein niedrigeres elektrisches Potenzial aufweist, und wobei ein Minus dargestellt wird als ein zweiter Zustand, wenn die erste Übertragungselektrode (11) ein niedrigeres elektrisches Potenzial und die zweite Übertragungselektrode (11) ein höheres elektrisches Potenzial aufweist;
  - Liefern eines Übertragungsstromes von der Übertragungselektrode (11), welche höheres elektrisches Potenzial aufweist, an das Innere des menschlichen Körpers (1), so dass der Übertragungsstrom (3) in der Form eines digitalen Signals durch die Oberfläche des menschlichen Körpers (1) zurück in das Innere des menschlichen Körpers (1) fließt und zu der Über-

- tragungselektrode (11) abfließt, welche das niedrigere elektrische Potenzial aufweist; und Induzieren einer Spannung in der Form eines digitalen Signals zwischen Empfangselektroden (21), welche an der Oberfläche des menschlichen Körpers installiert sind, durch den Übertragungsstrom (3), welcher durch die Oberfläche des menschlichen Körpers (1) fließt. 5
2. Verfahren nach Anspruch 1, wobei die elektrische Potenzialdifferenz erzeugt wird durch Anlegen eines elektrischen Signals des Sensors an den Übertragungselektroden. 10
  3. Verfahren nach Anspruch 1 oder 2, wobei der Sensor in einem Kapsel-Endoskop angeordnet ist und wobei das Verfahren das Erzeugen einer elektrischen Potenzialdifferenz zwischen Übertragungselektroden, welche an der Oberfläche des Kapsel-Endoskops installiert sind, umfasst. 15
  4. Verfahren nach Anspruch 3, wobei das Kapsel-Endoskop einen Übertragungsstrom fließen lässt von einer Übertragungselektrode zu der anderen Übertragungselektrode wenn ein zu übertragendes Signal ein Zustand eines digitalen Signals "1" oder "0" ist und einen Strom fließen lässt von der anderen Übertragungselektrode zu einer Übertragungselektrode wenn ein zu übertragendes Signal die andere Alternative eines digitalen Signals "1" oder "0" ist. 20 25 30
  5. Verfahren nach Anspruch 3, wobei eine Höhe des Stromes begrenzt wird durch Widerstands-Serienschalten an die jeweilige Übertragungselektrode. 35
  6. Verfahren nach Anspruch 5, wobei ein Kondensator mit jedem Widerstand parallel geschaltet ist.
  7. System zur Datenkommunikation im menschlichen Körper (1) zur Übertragung eines Signals von einem Sensor (10), welcher in den menschlichen Körper eingebracht wurde, nach außerhalb des menschlichen Körpers, aufweisend: 40
 

einen Sensor (10), welcher Übertragungselektroden (11) zur Erzeugung einer elektrischen Potenzialdifferenz in der Form eines digitalen Signals zwischen denselben aufweist, und einen Schalter (130) zum Schalten der Übertragungselektroden (11) gemäß zu übertragender Information, so dass ein Plus als ein erster Zustand dargestellt wird, wenn die erste Übertragungselektrode (11) ein höheres elektrisches Potenzial und die zweite Übertragungselektrode ein niedrigeres elektrisches Potenzial aufweist, und ein Minus dargestellt wird als ein zweiter Zustand, wenn die erste Übertragungselektrode (11) ein niedrigeres elektrisches Po- 45 50 55
- tenzial und die zweite Übertragungselektrode ein höheres elektrisches Potenzial aufweist, und zur Lieferung eines Übertragungsstromes (3) von der Übertragungselektrode (11), welche das höhere elektrische Potenzial aufweist, an das Innere des menschlichen Körpers, um den Übertragungsstrom in der Form eines digitalen Signals durch die Oberfläche des menschlichen Körpers zurück in das Innere des menschlichen Körpers fließen zu lassen und um den Übertragungsstrom zu der Übertragungselektrode (11) abfließen zu lassen, welche das niedrigere elektrische Potenzial aufweist; und einen Empfänger, welcher geeignet ist zur Installation an der Oberfläche des menschlichen Körpers (1), um eine Spannung in der Form eines digitalen Signals zwischen Empfangselektroden des Empfängers (20) aus dem Übertragungsstrom (3), welcher von der elektrischen Potenzialdifferenz erzeugt wurde, zu induzieren.
8. System nach Anspruch 7, wobei die Übertragungselektroden (11) an der Oberfläche des Sensors (10) installiert sind, um elektrisch isoliert zu sein.
  9. System nach Anspruch 7 oder 8, wobei die Übertragungselektroden (11) elektrisch mit einer internen Schaltung des Sensors (10) verbunden sind, um ein elektrisches Signal, welches von der internen Schaltung erzeugt wurde, zu empfangen.
  10. System nach Anspruch 8, wobei die Übertragungselektroden (11) dreidimensional gebildet sind.
  11. System nach einem der Ansprüche 7 bis 10, wobei die Übertragungselektroden (11) eine erste Elektrode und eine zweite Elektrode beinhalten, welche beide Enden des Sensors (10) umgeben.
  12. System nach einem der Ansprüche 7 bis 10, wobei die Übertragungselektroden (11) eine erste Elektrode beinhalten, welche ein Ende des Sensors (10) umgibt, und eine zweite Elektrode, welche das andere Ende des Sensors (10) als eine Bandform bedeckt.
  13. System nach einem der Ansprüche 7 bis 10, wobei die Übertragungselektroden (11) eine erste Elektrode und eine zweite Elektrode beinhalten, welche entsprechend beide Enden des Sensors (10) als eine Bandform bedecken.
  14. System nach einem der Ansprüche 7 bis 10, wobei die Übertragungselektroden (11) eine erste Elektrode und eine zweite Elektrode beinhalten, welche symmetrisch entlang einer längeren Achse des Sensors (10) geformt sind.

15. System nach einem der Ansprüche 7 bis 14, wobei der Isolator zur Isolierung der Übertragungselektroden (11) (die Oberfläche des Sensors (10)) aus einem aus PEEK, Polyethylen und Polypropylen hergestellt ist.
16. System nach einem der Ansprüche 7 bis 15, wobei der Isolator zum Isolieren der Übertragungselektroden (11) (die Oberfläche des Sensors (10)) mit Parlylen beschichtet ist.
17. System nach einem der Ansprüche 7 bis 16, wobei die Übertragungselektroden (11) aus einem leitfähigen Material hergestellt sind, welches für den menschlichen Körper (1) harmlos ist.
18. System nach Anspruch 17, wobei das leitfähige Material SUS316L oder Gold ist.
19. Kapsel-Endoskop, welches zum Einbringen in den menschlichen Körper (1) geeignet ist, aufweisend:

eine Beleuchtungsvorrichtung (12) zur Anstrahlung des Inneren des menschlichen Körpers (1);  
 eine Linse (13) zur Fokussierung von Licht, welches von dem Inneren des menschlichen Körpers (1) einfällt;  
 einen CMOS-Bildsensor (14) zum Aufnehmen und Verarbeiten eines Videosignals aus dem Licht, welches von der Linse (13) fokussiert wird, um ein elektrisches Signal gemäß dem Videosignal zu erzeugen;  
 ein Gehäuse zur Aufnahme der Beleuchtungsvorrichtung, der Linse (13) und des CMOS-Bildsensors (14);  
 Übertragungselektroden (11), welche an der Oberfläche des Gehäuses zum Empfang des elektrischen Signals, zur Erzeugung einer elektrischen Potenzialdifferenz in der Form eines digitalen Signals zwischen den Übertragungselektroden (11) gemäß dem elektrischen Signal installiert sind; und  
 einen Schalter (130) zum Schalten der Übertragungselektroden (11) gemäß der zu übertragenden Information, so dass ein Plus als ein erster Zustand dargestellt wird wenn die erste Übertragungselektrode (11) ein höheres elektrisches Potenzial und die zweite Übertragungselektrode (11) ein niedrigeres elektrisches Potenzial hat, und ein Minus dargestellt wird als ein zweiter Zustand wenn die erste Übertragungselektrode (11) ein niedrigeres elektrisches Potenzial und die zweite Übertragungselektrode (11) ein höheres elektrisches Potenzial hat, und zur Lieferung eines Übertragungsstromes (3) von der Übertragungselektrode (11), welche das höhere elektrische Potenzial aufweist an das Innere des menschlichen Körpers (1), um den Übertra-

- gungsstrom (3) in der Form eines digitalen Signals durch die Oberfläche des menschlichen Körpers (1) zurück in das Innere des menschlichen Körpers fließen zu lassen und um den Übertragungsstrom (3) zu der Übertragungselektrode (11) abfließen zu lassen, welche das niedrigere elektrische Potenzial aufweist.
20. Kapsel-Endoskop nach Anspruch 19, wobei die Übertragungselektroden (11) mit einer Ausgangsleitung des CMOS-Bildsensors (14) verbunden sind und an der Oberfläche des Gehäuses installiert sind, um elektrisch isoliert zu sein.
21. Kapsel-Endoskop nach Anspruch 19 oder 20, wobei die Übertragungselektroden (11) dreidimensional gebildet sind.
22. Kapsel-Endoskop nach einem der Ansprüche 19 bis 21, wobei die Übertragungselektroden (11) eine erste Elektrode und eine zweite Elektrode beinhalten, welche beide Enden des Gehäuses umgeben.
23. Kapsel-Endoskop nach einem der Ansprüche 19 bis 21, wobei die Übertragungselektroden (11) eine erste Elektrode aufweisen, welche ein Ende des Gehäuses umgibt und eine zweite Elektrode, welche das andere Ende des Gehäuses als eine Bandform bedeckt.
24. Kapsel-Endoskop nach einem der Ansprüche 19 bis 21, wobei die Übertragungselektroden (11) eine erste Elektrode und eine zweite Elektrode aufweisen, welche entsprechend beide Enden des Gehäuses als eine Bandform bedecken.
25. Kapsel-Endoskop nach einem der Ansprüche 19 bis 21, wobei die Übertragungselektroden (11) eine erste Elektrode und eine zweite Elektrode aufweisen, welche symmetrisch entlang einer längeren Achse des Gehäuses gebildet sind.
26. Kapsel-Endoskop nach einem der Ansprüche 19 bis 25, wobei die Oberfläche des Gehäuses hergestellt ist aus einem aus PEEK, Polyethylen und Polypropylen.
27. Kapsel-Endoskop nach Anspruch 26, wobei der Isolator zum Isolieren der Übertragungselektroden (11), das heißt die Oberfläche des Sensors (10), mit Parlylen beschichtet ist.
28. Kapsel-Endoskop nach einem der Ansprüche 19 bis 27, wobei die Übertragungselektroden (11) aus einem leitfähigen Material hergestellt sind, welches für den menschlichen Körper harmlos ist.
29. Kapsel-Endoskop nach Anspruch 28, wobei das leit-

- fähige Material SUS316L oder Gold ist.
30. Kapsel-Endoskop nach einem der Ansprüche 19 bis 29, wobei die Vorderseite des Gehäuses als ein kupfelförmiges Licht empfangendes Fenster (17) und die Rückseite des Gehäuses als ein rechteckiger Behälter (18) gebildet ist.
31. Kapsel-Endoskop nach Anspruch 30, wobei das Licht empfangende Fenster (17) aus einem für den menschlichen Körper harmlosen und lichtdurchlässigen Material gebildet ist.
32. Kapsel-Endoskop nach Anspruch 30 oder 31, wobei nichtreflektierende Beschichtung an den inneren und äußeren Oberflächen des Lichts empfangenden Fensters (17) bereitgestellt ist.
33. Kapsel-Endoskop nach einem der Ansprüche 19 bis 32, wobei die Beleuchtungsvorrichtung (12) eine LED ist.
34. Kapsel-Endoskop nach einem der Ansprüche 19 bis 33, wobei die LED eine variable Betriebszeit zwischen 5ms - 200ms hat.
35. Kapsel-Endoskop nach Anspruch 19, wobei der CMOS-Bildsensor (14) aufweist:
- ein Pixelfeld (100) zum Aufnehmen und Speichern des Videosignals;
  - eine Leseschaltung (110) zum sequenziellen Holen eines Videosignals von dem Pixelfeld (100);
  - eine Kodierschaltung (120) zum Kodieren eines Ausgangssignals der Leseschaltung;
  - eine Schaltschaltung (130) zum Ändern der Polarität einer Ausgangsleitung, welche mit den Übertragungselektroden verbunden ist, gemäß dem kodierten Signal, um das elektrische Signal zu erzeugen;
  - eine Strombegrenzungsschaltung (140) zum Verhindern des Fließens eines Stromes über einem bestimmten Wert;
  - eine Steuerschaltung (150) zur Steuerung des Betriebs der Beleuchtungsvorrichtung und des Betriebs des CMOS-Bildsensors; und
  - ein Schwingkreis zur Erzeugung eines Pulses.
36. Kapsel-Endoskop nach Anspruch 35, wobei das Pixelfeld (100) geeignet ist, das Videosignal aufzunehmen und zu speichern, während die Beleuchtungsvorrichtung abstrahlt.
37. Kapsel-Endoskop nach Anspruch 35, wobei die Leseschaltung (110) geeignet ist, das elektrische Signal sequentiell zu holen und zu verarbeiten, während die Beleuchtungsvorrichtung abgeschaltet ist.
38. Kapsel-Endoskop nach Anspruch 35, wobei die Kodiereinheit (120) angepasst ist, PSK-Kodierung durchzuführen.
39. Kapsel-Endoskop nach Anspruch 35, wobei die Schaltschaltung (130) geeignet ist, die Polarität der Ausgangsleitung zu ändern durch Fließenlassen eines Stromes von der ersten Elektrode zu der zweiten Elektrode wenn das kodierte Signal "1" ist und Fließenlassen eines Stromes von der zweiten Elektrode zu der ersten Elektrode wenn das kodierte Signal "0" ist.
40. Kapsel-Endoskop nach Anspruch 35, wobei die Strombegrenzungsschaltung (140) geeignet ist, den Strom nicht größer als 5mA zu halten.
41. Kapsel-Endoskop nach Anspruch 35, wobei die Strombegrenzungsschaltung (140) konstruiert ist durch Widerstandsschalten seriell an Ausgangsleitungen je der Schaltschaltung.
42. Kapsel-Endoskop nach Anspruch 41, wobei die Strombegrenzungsschaltung (140) ferner einen Kondensator aufweist, welcher entsprechend an den Widerstand parallel geschaltet ist.

#### Revendications

1. Procédé de communication de données destiné à émettre un signal à partir d'un capteur se trouvant dans le corps humain vers l'extérieur du corps humain, le procédé comprenant les étapes qui consistent :
- à générer une différence de potentiel électrique sous la forme d'un signal numérique entre des électrodes émettrices (11) installées sur la surface d'un capteur (10) ;
  - à commander les électrodes émettrices (11) en fonction des informations à émettre, de sorte qu'un signe plus soit représenté comme un premier état lorsque la première électrode émettrice (11) a un potentiel électrique plus haut et la deuxième électrode émettrice (11) a un potentiel électrique plus bas, et un signe négatif soit représenté comme un deuxième état lorsque la première électrode émettrice (11) a un potentiel électrique plus bas et la deuxième électrode émettrice (11) a un potentiel électrique plus haut ;
  - à fournir un courant de conduction de l'électrode émettrice (11) ayant un potentiel électrique plus haut à l'intérieur du corps humain (1) de sorte que le courant de conduction (3) reflue sous la forme d'un signal numérique à travers la surface du corps humain (1) vers l'intérieur du corps hu-

- main (1) et circule vers l'électrode émettrice (11) ayant un potentiel électrique plus bas ; et à induire une tension sous la forme d'un signal numérique entre des électrodes réceptrices (21) installées sur la surface du corps humain par le courant de conduction (3) circulant à travers la surface du corps humain (1).
2. Procédé de la revendication 1, dans lequel la différence de potentiel électrique est générée en appliquant un signal électrique du capteur aux électrodes émettrices.
  3. Procédé selon la revendication 1 ou la revendication 2, dans lequel le capteur est situé dans un endoscope de type capsule et le procédé comprend le fait de générer une différence de potentiel électrique entre des électrodes émettrices installées sur la surface de l'endoscope de type capsule.
  4. Procédé de la revendication 3, dans lequel l'endoscope de type capsule amène un courant de conduction à circuler d'une première électrode émettrice à l'autre électrode émettrice lorsqu'un signal à émettre est un état d'un signal numérique "1" ou "0" et amène un courant à circuler de l'autre électrode émettrice à une première électrode émettrice lorsqu'un signal à émettre est l'autre alternative d'un signal numérique "1" ou "0".
  5. Procédé de la revendication 3, dans lequel une quantité du courant est limitée en reliant en série une résistance à l'électrode émettrice respectivement.
  6. Procédé de la revendication 5, dans lequel un condensateur est relié en parallèle à chaque résistance.
  7. Système pour communication de données dans le corps humain (1) destiné à émettre un signal à partir d'un capteur (10) placé dans le corps humain (1) vers l'extérieur du corps humain, comprenant :
 

un capteur (10), ayant des électrodes émettrices (11) destinées à générer entre elles une différence de potentiel électrique sous la forme d'un signal numérique, et un commutateur (130) pour commuter des électrodes émettrices (11) en fonction des informations à émettre de sorte qu'un signe plus soit représenté comme un premier état lorsque la première électrode émettrice (11) a un potentiel électrique plus haut et la deuxième électrode émettrice possède un potentiel électrique plus bas, et un signe négatif soit représenté comme un deuxième état lorsque la première électrode émettrice (11) a un potentiel électrique plus bas et la deuxième électrode émettrice possède un potentiel électrique plus haut, et pour fournir un courant (3) de conduction de l'électrode émettrice (11) ayant un potentiel électrique plus haut à l'intérieur du corps humain pour refluer le courant de conduction sous la forme d'un signal numérique à travers la surface du corps humain vers l'intérieur du corps humain et pour faire couler le courant de conduction à l'électrode émettrice (11) ayant un potentiel électrique plus bas ; et un récepteur conçu pour être installé sur la surface du corps humain (1) pour induire une tension sous forme d'un signal numérique entre des électrodes réceptrices du récepteur (20) à partir du courant (3) de conduction généré par la différence de potentiel électrique.
  8. Système de la revendication 7, dans lequel les électrodes émettrices (11) sont installées sur la surface du capteur (10) pour être isolées électriquement.
  9. Système de la revendication 7 ou de la revendication 8, dans lequel les électrodes émettrices (11) sont reliées électriquement à un circuit interne du capteur (10) pour recevoir un signal électrique généré à partir du circuit interne.
  10. Système de la revendication 8, dans lequel les électrodes émettrices (11) sont formées en trois dimensions.
  11. Système de l'une quelconque des revendications 7 à 10, dans lequel les électrodes émettrices (11) comportent une première électrode et une deuxième électrode qui entourent les deux extrémités du capteur (10).
  12. Système de l'une quelconque des revendications 7 à 10, dans lequel les électrodes émettrices (11) comportent une première électrode entourant une extrémité du capteur (10) et une deuxième électrode couvrant l'autre extrémité du capteur (10), sous forme de bande.
  13. Système de l'une quelconque des revendications 7 à 10, dans lequel les électrodes émettrices (11) comportent une première électrode et une deuxième électrode couvrant respectivement les deux extrémités du capteur (10), sous forme de bande.
  14. Système de l'une quelconque des revendications 7 à 10, dans lequel les électrodes émettrices (11) comportent une première électrode et une deuxième électrode formées de manière symétrique le long d'un plus long axe du capteur (10).
  15. Système de l'une quelconque des revendications 7 à 14, dans lequel l'isolant destiné à isoler les électrodes émettrices (11) (la surface du capteur (10)) est fait d'une matière choisie parmi la polyéthéré-

thercétone, le polyéthylène et le polypropylène.

16. Système de l'une quelconque des revendications 7 à 15, dans lequel l'isolant destiné à isoler les électrodes émettrices (11) (la surface du capteur (10)) est revêtu de parylène. 5
17. Système de l'une quelconque des revendications 7 à 16, dans lequel les électrodes émettrices (11) sont réalisées en un matériau conducteur sans danger pour le corps humain (1). 10
18. Système de la revendication 17, dans lequel le matériau conducteur est le SUS316L ou l'or. 15
19. Endoscope de type capsule conçu pour être placé dans le corps humain (1), comprenant :
- un dispositif (12) d'éclairage destiné à éclairer l'intérieur du corps humain (1) ; 20
  - une lentille (13) destinée à focaliser la lumière incidente de l'intérieur du corps humain (1) ;
  - un capteur (14) d'images CMOS destiné à capturer et à traiter un signal vidéo provenant de la lumière focalisée par la lentille (13) pour générer un signal électrique en fonction du signal vidéo ; 25
  - un boîtier destiné à contenir le dispositif d'éclairage, la lentille (13) et le capteur d'images CMOS (14) ;
  - des électrodes émettrices (11) installées sur la surface du boîtier pour recevoir le signal électrique, pour générer une différence de potentiel électrique sous la forme d'un signal numérique entre les électrodes émettrices (11) en fonction du signal électrique ; et 30
  - un commutateur (130) pour la commutation des électrodes émettrices (11) en fonction des informations à émettre de sorte qu'un signe plus soit représenté comme un premier état lorsque la première électrode émettrice (11) a un potentiel électrique plus haut et la deuxième électrode émettrice (11) a un potentiel électrique plus bas, et un signe négatif soit représenté comme un deuxième état lorsque la première électrode émettrice (11) a un potentiel électrique plus bas et la deuxième électrode émettrice (11) a un potentiel électrique plus haut, et pour fournir un courant (3) de conduction de l'électrode émettrice (11) ayant un potentiel électrique plus haut à l'intérieur du corps humain (1) pour refluer le courant de conduction (3) sous la forme d'un signal numérique à travers la surface du corps humain (1) vers l'intérieur du corps humain et pour faire couler le courant de conduction (3) à l'électrode émettrice (11) ayant un potentiel électrique plus bas. 40 45 50
20. Endoscope de type capsule de la revendication 19, 55
- dans lequel les électrodes émettrices (11) sont reliées à une ligne de sortie du capteur d'images CMOS (14) et sont installées sur la surface du boîtier pour être isolées électriquement.
21. Endoscope de type capsule de la revendication 19 ou de la revendication 20, dans lequel les électrodes émettrices (11) sont formées en trois dimensions.
22. Endoscope de type capsule de l'une quelconque des revendications 19 à 21, dans lequel les électrodes émettrices (11) comportent une première électrode et une deuxième électrode qui entourent les deux extrémités du boîtier.
23. Endoscope de type capsule de l'une quelconque des revendications 19 à 21, dans lequel les électrodes émettrices (11) comportent une première électrode entourant une extrémité du boîtier et une deuxième électrode couvrant l'autre extrémité du boîtier, sous forme de bande.
24. Endoscope de type capsule de l'une quelconque des revendications 19 à 21, dans lequel les électrodes émettrices (11) comportent une première électrode et une deuxième électrode couvrant respectivement les deux extrémités du boîtier, sous forme de bande.
25. Endoscope de type capsule de l'une quelconque des revendications 19 à 21, dans lequel les électrodes émettrices (11) comportent une première électrode et une deuxième électrode formées de manière symétrique le long d'un plus long axe du boîtier.
26. Endoscope de type capsule de l'une quelconque des revendications 19 à 25, dans lequel la surface du boîtier est faite d'une matière choisie parmi la polyétheréthercétone, le polyéthylène et le polypropylène.
27. Endoscope de type capsule de la revendication 26, dans lequel l'isolant destiné à isoler les électrodes émettrices (11), c'est-à-dire la surface du capteur (10), est recouvert de parylène.
28. Endoscope de type capsule de l'une quelconque des revendications 19 à 27, dans lequel les électrodes émettrices (11) sont réalisées en un matériau conducteur sans danger pour le corps humain (1).
29. Endoscope de type capsule de la revendication 28, dans lequel le matériau conducteur est le SUS316L ou l'or.
30. Endoscope de type capsule de l'une quelconque des revendications 19 à 29, dans lequel la partie avant du boîtier est formée comme une fenêtre (17) de réception de lumière en forme de dôme et la partie

- arrière du boîtier est formée comme un conteneur rectangulaire (18).
31. Endoscope de type capsule de la revendication 30, dans lequel la fenêtre (17) de réception de lumière est réalisée en un matériau sans danger pour le corps humain et laissant passer la lumière.
32. Endoscope de type capsule de la revendication 30 ou de la revendication 31, dans lequel un revêtement antiréfléchissant est prévu sur les surfaces intérieure et extérieure de la fenêtre (17) de réception de lumière.
33. Endoscope de type capsule de l'une quelconque des revendications 19 à 32, dans lequel le dispositif (12) d'éclairage est une diode électroluminescente.
34. Endoscope de type capsule de l'une quelconque des revendications 19 à 33, dans lequel la diode électroluminescente a un temps de fonctionnement compris dans l'intervalle de 5 ms-200 ms.
35. Endoscope de type capsule de la revendication 19, dans lequel le capteur d'images CMOS (14) comporte :
- une matrice (100) de pixels destinée à capturer et à stocker le signal vidéo ;
  - un circuit (110) de lecture destiné à extraire un signal vidéo à partir de la matrice (100) de pixels de manière consécutive ;
  - un circuit (120) de codage destiné à coder un signal de sortie du circuit de lecture ;
  - un circuit (130) de commutation destiné à changer la polarité d'une ligne de sortie reliée aux électrodes émettrices en fonction du signal codé pour générer le signal électrique ;
  - un circuit (140) de limitation de courant destiné à limiter la circulation d'un courant pour ne pas dépasser une certaine valeur ;
  - un circuit (150) de commande destiné à commander le fonctionnement du dispositif d'éclairage et le fonctionnement du capteur d'images CMOS ; et
  - un circuit oscillant destiné à générer une impulsion.
36. Endoscope de type capsule de la revendication 35, dans lequel la matrice (100) de pixels est conçue pour capturer et stocker le signal vidéo lors de l'éclairage par le dispositif d'éclairage.
37. Endoscope de type capsule de la revendication 35, dans lequel le circuit (110) de lecture est conçu pour extraire et traiter le signal électrique de manière consécutive lorsque le dispositif d'éclairage est éteint.
38. Endoscope de type capsule de la revendication 35, dans lequel le circuit (120) de codage est conçu pour réaliser un codage PSK.
39. Endoscope de type capsule de la revendication 35, dans lequel le circuit (130) de commutation est conçu pour changer la polarité de la ligne de sortie en amenant un courant à circuler de la première électrode à la deuxième électrode lorsque le signal codé est "1" et en amenant un courant à circuler de la deuxième électrode à la première électrode lorsque le signal codé est "0".
40. Endoscope de type capsule de la revendication 35, dans lequel le circuit (140) de limitation de courant est conçu pour maintenir le courant de façon à qu'il ne soit pas supérieur à 5 mA.
41. Endoscope de type capsule de la revendication 35, dans lequel le circuit (140) de limitation de courant est réalisé en reliant une résistance en série aux lignes de sortie du circuit de commutation respectivement.
42. Endoscope de type capsule de la revendication 41, dans lequel le circuit (140) de limitation de courant comporte en outre un condensateur relié respectivement en parallèle à la résistance.

FIG. 1

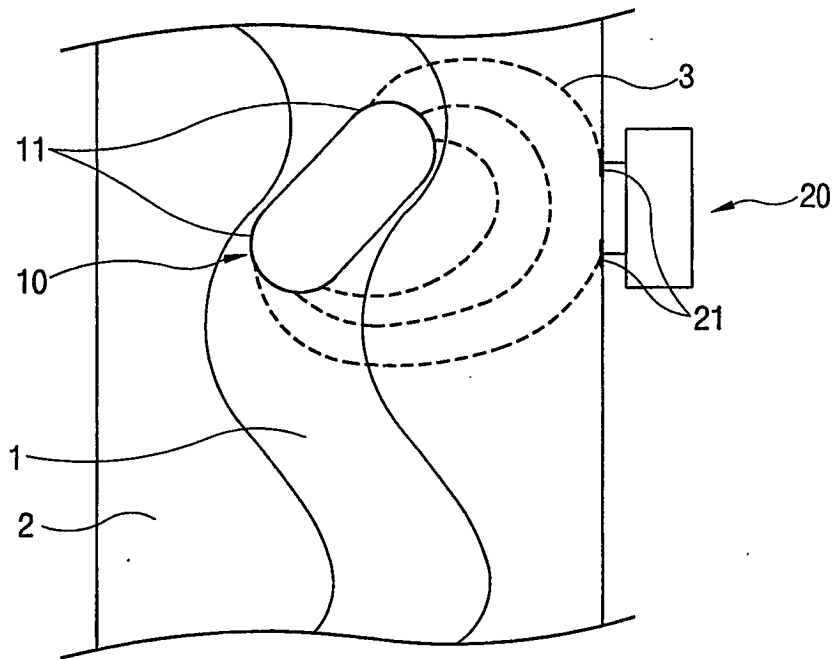

FIG. 2a

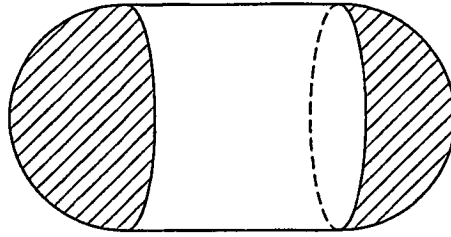

FIG. 2b

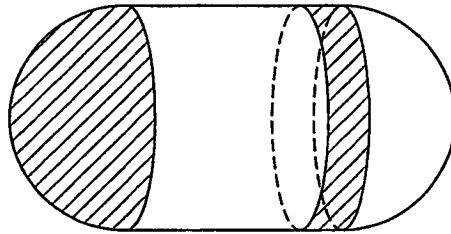

FIG. 2c

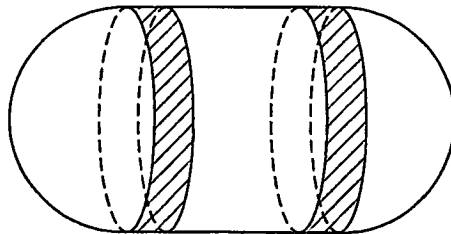

FIG. 2d

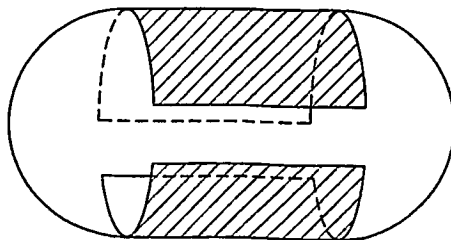

FIG. 3

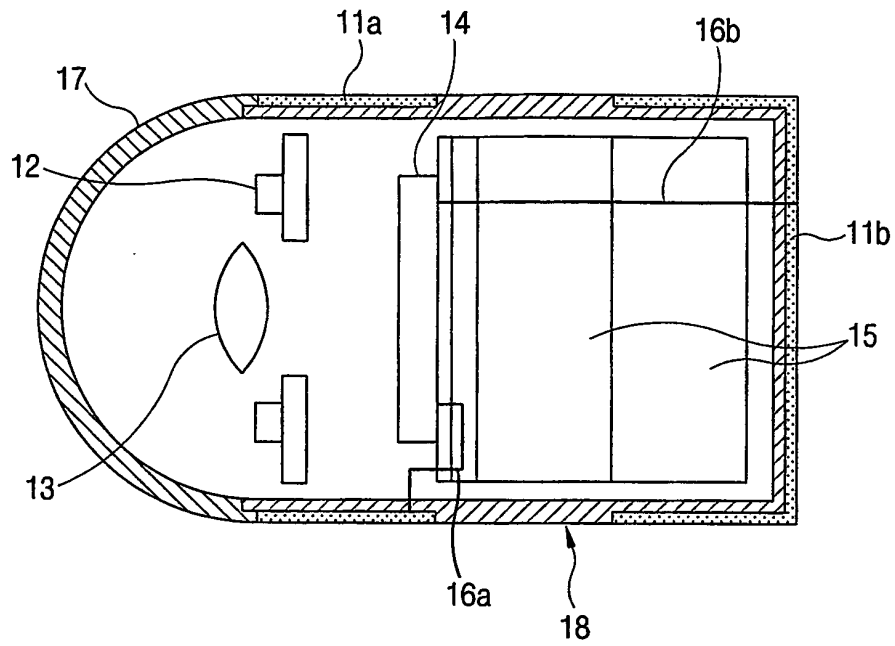
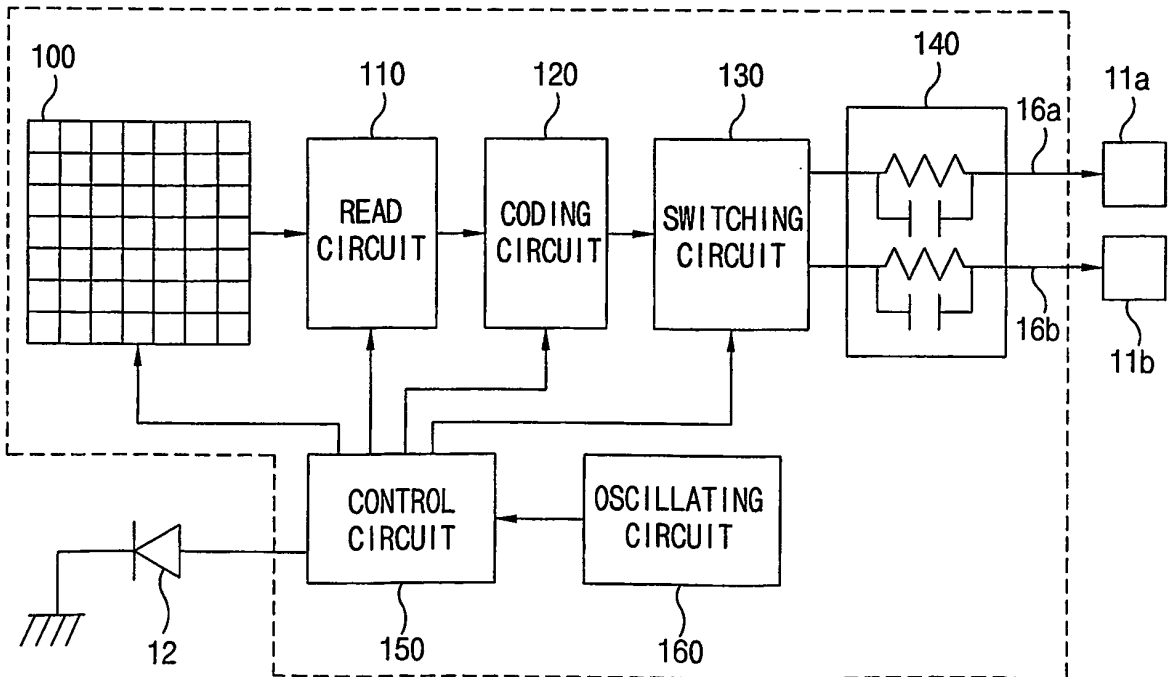

FIG. 4



**REFERENCES CITED IN THE DESCRIPTION**

*This list of references cited by the applicant is for the reader's convenience only. It does not form part of the European patent document. Even though great care has been taken in compiling the references, errors or omissions cannot be excluded and the EPO disclaims all liability in this regard.*

**Patent documents cited in the description**

- US 20020138009 A [0006]
- EP 0667115 A [0009]
- GB 2308481 A [0010]
- JP 60250731 B [0011]
- EP 0109184 A [0012]

**Non-patent literature cited in the description**

- **Sangeev Baskiyar.** A Real-time Fault Tolerant Intra-Body Network. *27th Arrival IEEE Conference on Local Compute Networks* [0007]
- **Wilfred Mokwa ; Uwe Schnakenberg.** Micro-Transponder Systems for Medical Applications. *IEEE Translations on Instrumentation and Measurement*, December 2001, vol. 50 (6 [0008])

专利名称(译)	用于人体数据通信的方法和系统及其传感器		
公开(公告)号	<a href="#">EP1593214A4</a>	公开(公告)日	2006-09-06
申请号	EP2003781095	申请日	2003-12-31
[标]申请(专利权)人(译)	韩国科学技术研究院		
申请(专利权)人(译)	韩国学院科技		
当前申请(专利权)人(译)	韩国学院科技		
[标]发明人	KIM TAE SONG PARK JONG OH KIM BYUNG KYU KIM JIN SEOK CHEUNG HAN CHO WON WOO YOON NAN YOUNG KIM YOUNG ROK		
发明人	KIM, TAE-SONG PARK, JONG-OH KIM, BYUNG-KYU KIM, JIN-SEOK CHEUNG, HAN CHO, WON-WOO YOON, NAN-YOUNG KIM, YOUNG-ROK		
IPC分类号	H04B13/00 A61B1/05 A61B5/00 A61B5/07		
CPC分类号	A61B1/041 A61B5/0028 A61B5/0031 H04B13/005		
优先权	1020030005059 2003-01-25 KR		
其他公开文献	EP1593214B1 EP1593214A1		
外部链接	<a href="#">Espacenet</a>		

摘要(译)

本发明提供了用于人体数据通信的方法和系统及其传感器。该方法和系统利用低电流和电压极性将信息通过人体传送到位于人体外部的接收器，使得它们不会对人体造成损害并实现低功耗和更好的接收灵敏度。此外，该传感器包含一个CMOS图像传感器，所有电路都集成在一起，没有无线电发射器和天线，因此它可以实现低价和小尺寸的胶囊型内窥镜。

