



Europäisches Patentamt
European Patent Office
Office européen des brevets



(11) **EP 1 206 213 B1**

(12) **EUROPEAN PATENT SPECIFICATION**

(45) Date of publication and mention
of the grant of the patent:
26.01.2005 Bulletin 2005/04

(21) Application number: **00960520.5**

(22) Date of filing: **24.08.2000**

(51) Int Cl.⁷: **A61B 5/00**

(86) International application number:
PCT/EP2000/008285

(87) International publication number:
WO 2001/013783 (01.03.2001 Gazette 2001/09)

(54) **OCULAR ANALYTE SENSOR**

AUGENANALYTFÜHLER

DETECTEUR D'ANALYTE DANS UN LIQUIDE OCULAIRE

(84) Designated Contracting States:
**AT BE CH CY DE DK ES FI FR GB GR IE IT LI LU
MC NL PT SE**

(30) Priority: **26.08.1999 US 150792 P
01.03.2000 US 185980 P**

(43) Date of publication of application:
22.05.2002 Bulletin 2002/21

(73) Proprietors:
• **Novartis AG
4056 Basel (CH)**
Designated Contracting States:
**BE CH LI CY DE DK ES FI FR GB GR IE IT LU MC
NL PT SE**
• **Novartis Pharma GmbH
1230 Wien (AT)**
Designated Contracting States:
AT

(72) Inventor: **MARCH, Wayne, Front
Galveston, TX 77551 (US)**

(74) Representative: **Grubb, Philip William et al
Novartis AG,
Corporate Intellectual Property,
Lichtstrasse 35
4002 Basel (CH)**

(56) References cited:
**WO-A-00/13580 WO-A-93/01745
WO-A-97/19188 WO-A-99/51142**

• **KOMIVES C ET AL: "IMPROVEMENT OF
OPTICAL FIBER BASED BIOSENSORS"
PROCEEDINGS OF THE ANNUAL
CONFERENCE OF THE ENGINEERING IN
MEDICINE AND BIOLOGY SOCIETY,US,NEW
YORK, IEEE, vol. CONF. 12, 1 November 1990
(1990-11-01), pages 478-479, XP000236249**

EP 1 206 213 B1

Note: Within nine months from the publication of the mention of the grant of the European patent, any person may give notice to the European Patent Office of opposition to the European patent granted. Notice of opposition shall be filed in a written reasoned statement. It shall not be deemed to have been filed until the opposition fee has been paid. (Art. 99(1) European Patent Convention).

Description

[0001] An ophthalmic lens comprising a receptor moiety can be used to determine the amount of an analyte in an ocular fluid which is accessible to light. The receptor moiety can bind either a specific analyte or a detectably labeled competitor moiety. The amount of detectably labeled competitor moiety which is displaced from the receptor moiety by the analyte is measured and provides a means of determining analyte concentration in an ocular fluid, such as tears, aqueous humor, or interstitial fluid. The concentration of the analyte in the ocular fluid, in turn, indicates the concentration of the analyte in a fluid or tissue sample of the body that is not as accessible, such as blood or intracellular fluid.

[0002] Various noninvasive or minimally invasive methods to measure analytes, particularly glucose, have been described. For example, March, U.S. Patents 3,958,560 and 4,014,321, discloses a glucose sensor wherein a patient's eye is automatically scanned using a source of light at one side of the cornea. A sensor located at the other side of the cornea detects the light that passes through the cornea. The level of glucose which rotates the plan of polarized light in the aqueous humor of the patient is a function of the amount of radiation detected. However, this sensor system is not necessarily specific or widely applicable to detection of analytes other than glucose, because it does not exploit the use of biological molecules which can detect glucose or other analytes in a body tissue or fluid sample. Biological molecules, as is well known, can provide very specific and sensitive detection reagents for particular analytes.

[0003] Schultz, U.S. Patent 4,344,438, discloses a system for monitoring low molecular weight compounds in blood plasma by optical means, which involves a chamber which contains specific receptor sites for the plasma constituent to be analyzed. This system is very invasive, however, because it must be implanted within the blood stream using a hypodermic needle. The system also inherently contains the risks of clotting around the device, obstruction, and other adverse reactions, including immune reactions, general irritation, and foreign body reactions.

[0004] The invention is as defined in the appended set of claims.

[0005] Embodiments of the present invention overcome these disadvantages in the prior art by employing an ophthalmic lens comprising a receptor moiety which comprises an analyte/competitor moiety binding site to detect an analyte in an ocular fluid. Concentration of a wide variety of analytes can be measured using an ophthalmic lens according to embodiments of the invention. Such analytes include, but are not limited to, electrolytes and small molecules (e.g., sodium, potassium, chloride, phenylalanine, uric acid, galactose, glucose, cysteine, homocysteine, calcium, ethanol, acetylcholine and acetylcholine analogs, ornithine, blood urea nitrogen, cre-

atinine), metallic elements (e.g., iron, copper, magnesium), polypeptide hormones (e.g., thyroid stimulating hormone, growth hormone, insulin, luteinizing hormone, choriongonadotrophic hormone), chronically administered medications (e.g., dilantin, phenobarbital, propranolol), acutely administered medications (e.g., cocaine, heroin, ketamine), small molecule hormones (e.g., thyroid hormones, ACTH, estrogen, cortisol, estrogen, and other metabolic steroids), markers of inflammation and/or allergy (e.g., histamine, IgE, cytokines), lipids (e.g., cholesterol), plasma proteins and enzymes (e.g., complement, coagulation factors, liver function enzymes, heart damage enzymes, ferritin), markers of infection (e.g., virus components, immunoglobulins such as IgM, IgG, etc., proteases, protease inhibitors), and/or metabolites (e.g., lactate, ketone bodies).

[0006] Ophthalmic lenses according to embodiments of the invention can be used to monitor the course of therapy or the level of disease in mammals, including primates and, preferably, humans. In addition, because ophthalmic lenses according to embodiments of the invention provide a way to detect analytes noninvasively, they provide distinct advantages over more traditional forms of monitoring such levels. Ophthalmic lenses according to embodiments of the invention also are useful for diagnostic purposes, for example to test for pregnancy (to detect β -HCG), to assess blood chemistry (electrolytes, Ca_2PO_4 , magnesium, bilirubin, alkaline phosphatase, lactate dehydrogenase, alanine aminotransferase, etc.), and to detect infection (e.g., by detecting components of viruses such as CMV, EBV, hepatitis, and HIV, or bacteria, such as *Staphylococcus*, *Streptococcus*, etc.). They also are useful for monitoring blood levels of test compounds during the course of assessing the compounds for use as potential therapeutics.

[0007] Ophthalmic lenses according to embodiments of the invention can be worn chronically to provide repeated analyte measurements or can be worn for a single analyte measurement. Both qualitative and quantitative measurements can be performed.

Ophthalmic Lens

[0008] An ophthalmic lens according to embodiments of the invention can be a removable lens, such as a contact lens, or a permanently implanted lens, such as an intraocular lens, a subconjunctival lens, or an intracorneal lens. See US Serial Nos. 60/150,792 and 60/185,980, the patent applications the priority of which is claimed for this invention. Permanently implanted lenses are particularly well-suited for use in individuals who have compromised ocular function (e.g., cataracts) and also have chronic conditions which require analyte measurement, such as diabetics.

[0009] Ophthalmic lenses can be corrective lenses or can be constructed so that they do not affect visual acuity. Contact lenses optionally can comprise a tint and are preferably disposable, which reduces the risk of infec-

tion for the user. As used herein, the term "ophthalmic lens" may also refer to a shunt or implant that may rest in the cul de sac of the eye.

Receptor Moiety

[0010] The ophthalmic lens comprises a receptor moiety. The receptor moiety comprises a binding site for the analyte to be detected. The binding site also binds a moiety which competes with the analyte for binding and is therefore referred to herein as an "analyte/competitor moiety binding site." Binding of both the competitor moiety and the analyte to the analyte/competitor moiety binding site is reversible. The nature of the molecule used as the receptor moiety depends on the particular analyte to be detected, but minimally includes that portion of the molecule which is sufficient to contain an analyte/competitor moiety binding site.

[0011] For example, if glucose is the analyte to be detected, the receptor moiety preferably is concanavalin A (Mansouri & Schultz, *Bio/Tech* 2, 385, 1984), although other moieties, such as antibodies, boronic acid, a genetically engineered bacterial fluoriprotein, or glucose oxidase also can be used. If phenylalanine is the analyte to be detected, the receptor moiety preferably comprises the active site of phenylalanine hydroxylase. It is well within the skill of those knowledgeable in the art to determine other analyte-receptor moiety binding pairs, such as uric acid-uricase, alcohol-alcohol dehydrogenase, copper-ceruloplasmin, galactose-galactokinase, cysteine- and/or homocysteine-cystathionine synthetase, acetylcholine-acetylcholinesterase, ornithine-diamine oxidase, and the like.

Competitor Moiety

[0012] For use in detecting an analyte, an ophthalmic lens according to the invention comprises a competitor moiety having a detectable label. The competitor moiety competes with the analyte for binding to the analyte/competitor moiety binding site. The detectable label can intrinsically be part of the competitor moiety. Alternatively, the detectable label can be a label which is not naturally associated with the competitor moiety but which is attached by means of a chemical linkage, such as a covalent bond. In preferred embodiments, the competitor moiety comprises a fluorescent label. Other detectable labels, such as luminescent or colorimetric labels, also can be used.

[0013] Again, it is well within the skill of those in the art to select a competitor moiety which will compete with an analyte for binding to a particular analyte/competitor moiety binding site. For example, competitor moieties which can be used with the analyte-receptor moiety binding pairs disclosed above include fluorescein dextran (which competes with glucose for binding to concanavalin A), fluorescein polyglutamylurate (which competes with uric acid for binding to uricase), fluorescein

nanolol (which competes with alcohol for binding to alcohol dehydrogenase), fluorescein-glutamine phenylacetate (which competes with phenylalanine for binding to phenylalanine hydroxylase), fluorescein-erythrocytrophin (which competes with copper for binding to ceruloplasmin), fluorescein- 2,3,6-tri-O-methyl galactose (which competes with galactose for binding to galactokinase), fluorescein-S-adenosyl polyhomocysteine (which competes with cysteine and homocysteine for binding to cystathionine synthetase), fluoropolyglutamyl prostigmine (which competes with acetylcholine for binding to acetylcholinesterase), and fluorospermine (which competes with ornithine for binding to diamine oxidase).

[0014] Most preferably, the detectable label is more readily detectable when the competitor moiety is not bound to the analyte/competitor moiety binding site. Thus, fluorescent labels, such as fluorescein, indocyanine green, malachite green, and rhodamine, which are quenched when the competitor moiety is bound but are unquenched when the competitor moiety is not bound, are preferred for use in ophthalmic lenses according to embodiments of the invention.

Providing Receptor and Competitor Moieties in an Ophthalmic Lens

[0015] A variety of options are available for providing the receptor and competitor moieties in an ophthalmic lens. Construction of various types of ophthalmic lenses is well known in the art. Construction of contact lenses is taught, for example, in U.S. Patents 5,965,631, 5,894,002, 5,849,811, 5,807,944, 5,776,381, 5,426,158, 4,099,859, 4,229,273, 4,168,112, 4,217,038, 4,409,258, 4,388,164, 4,332,922, 4,143,949, 4,311,573, 4,589,964, and 3,925,178.

[0016] Construction of intraocular lens implants is taught, *inter alia*, in U.S. Patents 6,051,025, 5,868,697, 5,762,836, 5,609,640, 5,071,432, 5,041,133, and 5,007,928. Subconjunctival lenses are taught, for example, in U.S. Patents 5,476,511, 5,400,114, and 5,127,901. Intracorneal lenses are taught, *inter alia*, in U.S. Patents 6,090,141, 5,984,961, 5,123,921, and 4,799,931.

[0017] In one embodiment, the receptor moiety is covalently bound to the ophthalmic lens material. In another embodiment, the ophthalmic lens comprises a polymer meshwork containing pores. The pores are of a size which permit the competitor moiety to bind reversibly to the analyte/competitor moiety binding site, but which prevent the receptor moiety and the competitor moiety from diffusing out of the ophthalmic lens. Suitable polymers for this purpose are known in the art and include hydrogels, such as stable polymers of polyethylene glycol hydrogel (PEGH) and modified polyvinylalcohol, such as nelfilcon A.

[0018] In another embodiment, the ophthalmic lens comprises a receptor moiety layer, a polyelectrolyte layer, and a competitor moiety layer. The polyelectrolyte

layer includes one or more polyelectrolytes, which are generally high molecular weight polymers with multiple ionic or ionizable functional groups. At least one polyelectrolyte in the polyelectrolyte layer has a charge opposite to the overall charge of the receptor moiety and competitor moiety layers. Suitable polyelectrolytes include positively charged PDDA (polydiallyldimethylammonium chloride) and negatively charged PAA (polyacrylic acid). Assembly of the layers is based upon sequential adsorption of oppositely charged polyions. The sensor and spacing polyelectrolytes are deposited as uniform thin films (1-10 nm) in 10-15 deposition cycles onto the porous polyvinyl alcohol or hydrogen matrix, resulting in only a 100-500 nm thick coating for the sensing film, which is highly biocompatible. A typical sequence for construction of an ophthalmic lens suitable for glucose detection involves a deposition cycle of ultrathin (1-10 nm) films of PDDA, PAA, PDDA, concanavalin A, PDDA, PAA, PDDA, fluorescein dextran, PDDA, PAA, PDDA, PAA, concanavalin A, PAA, fluorescein dextran, PAA, etc. Technology for constructing ophthalmic lenses comprising such layers is taught, for example, in WO 99/35520.

[0019] An ophthalmic lens according to embodiments of the invention can be provided in a kit, together with instructions for measuring analyte concentration as described below. The invention provides kits which are intended for individual patient use, in which the ophthalmic lens typically is a contact lens, as well as kits for medical practitioners, which can comprise any of the ophthalmic lenses or their equivalents described herein.

Analyte Sensor System

[0020] An ophthalmic lens according to embodiments of the invention can be used in an analyte sensor system. The analyte sensor system comprises an ophthalmic lens and a detector configured to detect the detectable label. For example, if the label is a luminescent label, the detector may include a luminometer; if the label is a colorimetric label, the detector may include a colorimeter; if the label is a fluorescent label, the detector may include a fluorophotometer. Construction of such devices is well known in the art. Light with wavelengths which will excite the fluorescent label can be provided, for example, by a laser or a light source, such as a light-emitting diode. A fluorophotometer suitable for use with embodiments of the invention can be constructed using a light-emitting diode from Power Technology, Inc. (Little Rock, AR) (see March *et al.*, *Diabetes Technol. & Ther.* 2, 27-30, 2000).

[0021] The detector can be a free-standing device, a table-top device, or a hand-held device. For convenience, the detector can be a miniaturized device and may be worn or carried as a personal accessory, for example, mounted in the frame of a pair of eyeglasses, clipped to an article of clothing, such as a shirt or sweater, hung around the neck, worn around the wrist, or

clipped to a belt or a key ring.

[0022] Using an ophthalmic lens in an analyte sensor system, as described above, embodiments of the invention provides methods of measuring analyte concentration in an ocular fluid. This measurement can, in turn, be manipulated to provide a measurement of the analyte's concentration in a body tissue or a fluid, such as blood or intracellular fluid. The relationship between glucose concentration in the aqueous humor and the blood, for example, is well known. See Süllmann, in *HANDBUCH DER PHYSIOLOGISCHEN CHEMIE*, Vol. II/a, p. 867 ff., Springer, Berlin, 1956; Graymore, in *THE EYE*, Vol. I, p. 348, Davson, ed., Academic Press, NY, 1962; De Berardinis *et al.*, *Exp. Eye Res.* 4, 179, 1965; Pohjola, *Acta Ophthalmologica Suppl.* 88, 1966; Reim *et al.*, *Ophthalmologica* 154, 39-50, 1967; Kinsey & Reddy, in Prince, ed., *THE RABBIT AND EYE RESEARCH*, C.C. Thomas, Springfield, IL, 1964, p. 218. The relationship between the concentration of another analyte in a body tissue or fluid and the concentration of the analyte in an ocular fluid can be determined by methods well known in the art. See, for example, March *et al.*, *Diabetes Care* 5, 259-65, 1982. The detector can be configured to convert the measurement of the analyte concentration into a value which reflects the concentration of the analyte in the relevant body tissue or fluid, e.g., blood.

[0023] If desired, the analyte sensor system also can comprise a transmitter configured to transmit a signal representing whether the detectable label is detected and/or an amount of the detectable label that is detected. A device configured to vary the concentration of the analyte in a body fluid or tissue, such as an infusion pump or other pump, may receive the signal and may vary the concentration response to the signal. The signal from the analyte sensor system may comprise a continuous or discontinuous telemetry signal generated by the detector. The pump may, in response to the signal, adjust the levels of the analyte in the body by providing the user with the appropriate amount of a regulator moiety, such as insulin. Infusion pumps are well known in the art for delivering a selected medication to a patient including humans and other animals in accordance with an administration schedule which can be preselected or, in some instances, preprogrammed. Pumps for use in this invention can be worn externally or can be directly implanted into the body of a mammal, including a human, to deliver a specific medication such as insulin to the mammal in controlled doses over an extended period of time. Such pumps are well known and are described, for example, in U.S. Patents 5,957,890, 4,923,375, 4,573,994, and 3,731,681. Medications which should optimally be maintained at a constant level, such as phenobarbital, baclofen, theophylline, and cardiac and blood pressure medications, also can be provided by means of an infusion pump.

Illustrative embodiments

[0024] Illustrative embodiments of the analyte sensor system according to embodiments of the invention are shown in FIGS. 1 and 2. FIG. 1 is a schematic view of an analyte sensor system employing a contact lens **1**, a radiation detector **5**, such as a fluorophotometer, and a radiation source **2**, such as a laser (which preferably is of low power) or light emitting diode, which emits light **3** with a first wavelength which will excite the fluorescent label in competitor moieties contained within the contact lens **1**. In response to the light **3**, competitor moieties which are not bound to receptor moieties will thereby emit light **4** of a second different wavelength (e.g., by fluorescence), which can be detected and measured by a radiation detector **5**. The radiation detector **5** and the radiation source **2** may be embodied together as a handheld unit, as shown in FIG. 1.

[0025] Conveniently, a miniaturized version of the radiation source **2** and the radiation detector **5** can be configured to be built into a pair of eyeglasses. An exemplary embodiment of this is shown in FIGS. 2A and 2B. The analyte sensor system shown in FIGS. 2A and 2B employs an intraocular lens **8**, which comprises a polymer **9** containing receptor moieties and fluorescently labeled competitor moieties. A light-emitting diode **6** is mounted in the frame of a pair of eyeglasses **7**. The light-emitting diode **6** emits light **3** with a first wavelength which will excite the fluorescent label in the competitor moieties. Competitor moieties which are not bound to receptor moieties will thereby emit light **4** of a second different wavelength, which can be detected and measured by a fluorophotometer **5**, which is mounted together with the light-emitting diode **6** in the eyeglasses frame **7**. A telemetry signal **10** is transmitted to an infusion pump **11**, which can provide a regulator moiety, such as insulin, to maintain suitable levels of the analyte in the body. The telemetry signal **10** may be analog or digital and may be transmitted via wire or cable, such as wire **60**, or wirelessly, such as via radio frequency or infrared transmission. Where the telemetry signal **10** is transmitted wirelessly, the analyte sensor system may include antennas **50, 51**, for such wireless transmission. Antenna **50** may, if desired, be embedded within eyeglass frame **7**. As shown in FIG. 2C, the antennas **50, 51** may be coupled with a respective wireless transmitter **52** and wireless receiver **53**.

[0026] The telemetry signal **10** may include qualitative information as to whether or not the analyte is detected by the radiation detector **5**. For example, where the detected light **4** is at or exceeds a predetermined threshold, the telemetry signal **10** may represent a "detected" state (such as the existence of telemetry signal **10**). Where the detected light **4** is below the threshold, the telemetry signal **10** may represent a "not detected" state (such as the absence of telemetry signal **10**). Alternatively, the telemetry signal **10** may indicate a change in analyte concentration. Telemetry signal **10** also may

provide a warning signal if the analyte concentration is above or below a preset range.

[0027] Optionally, the telemetry signal **10** may include quantitative information as to how much light **4** is detected by the radiation detector **5**. For instance, the telemetry signal **10** may be varied in amplitude and/or frequency responsive to the amount of light **4** detected, where the amplitude and/or frequency represents the amount of light **4**. As another example, the telemetry signal **10** may include digital data representing the amount of detected light **4**.

[0028] If the telemetry signal **10** is analog, the telemetry signal **10** may be generated by the detector **5**, which may include a modulator for generation of the telemetry signal **10**. If the telemetry signal **10** is digital, the telemetry signal **10** may be generated by an analog-to-digital ("A/D") converter **70**. Also, the amount of the light **4** detected by the radiation detector **5** may be shown on a display **71** (which may include a display driver), such as a CRT screen or liquid crystal display ("LCD").

[0029] All patents and patent applications cited in this disclosure are expressly incorporated herein by reference. The above disclosure generally describes the present invention. A more complete understanding can be obtained by reference to the following specific examples which are provided for purposes of illustration only and are not intended to limit the scope of the invention.

EXAMPLE 1

Construction of an intraocular glucose sensor

[0030] A structurally stable polymer of polyethylene glycol hydrogel (PEGH, Shearwater Polymers, Inc.) is used to construct an intraocular glucose sensor. PEGH is immobilized in an intraocular lens (Alcon Laboratories, 6 mm circumference, 1 mm thickness). Chemically immobilized pendant tetramethylrhodamine isothiocyanate concanavalin A (TRITC-ConA, Sigma) is incorporated into the PEGH as the receptor moiety and fluorescein isothiocyanate dextran (FITC-dextran, Sigma) is incorporated as the competitor moiety by polymerization under UV light, as described by Ballerstadt & Schultz, *Anal. Chim. Acta* 345, 203-12, 1997, and Russell & Pishko, *Anal. Chem.* 71, 3126-32, 1999. While the FITC-dextran is bound to the TRITC-ConA, the FITC fluorescence is quenched via a fluorescence resonance energy transfer. Increased glucose concentration frees the FITC-dextran and results in fluorescence which is proportional to glucose concentration.

[0031] FIG. 4 shows the relationship between fluorescence intensity of our fluorescent intraocular lens at three glucose concentrations *in vitro*. A linearly proportional relationship occurs between 0 and 500 mg% at 518 nm, which is the peak of fluorescein fluorescence. The peak at 575 nm is due to the rhodamine in the TRITC-ConA.

EXAMPLE 2*Implantation of an intraocular glucose sensor in vivo*

[0032] The intraocular lens glucose sensor described in Example 1 is implanted into the anterior chamber of the eye of a living New Zealand rabbit with a blood glucose concentration of 112 mg%. The implant is visible as a bright spot of green fluorescence (518 nm) within the eye. Careful examination with a biomicroscope slit lamp shows no sign of toxicity, rejection, or any reaction 6 months after implantation.

Claims

1. An ophthalmic lens for detecting an analyte in an ocular fluid, comprising:

a receptor moiety which comprises an analyte/competitor moiety binding site, and a competitor moiety comprising a detectable label.

2. The ophthalmic lens of claim 1, which is selected from the group consisting of a contact lens, an intraocular lens, a subconjunctival lens, and an intra-corneal lens.

3. The ophthalmic lens according to claim 1 or 2, wherein the analyte is selected from the group consisting of an electrolyte, a metallic element, a polypeptide hormone, a chronically administered medication, an acutely administered medication, a small molecule hormone, a marker of inflammation, a marker of allergy, a lipid, a protein, a marker of infection, and a metabolite.

4. The ophthalmic lens according to any one of claims 1 to 3, wherein the ocular fluid is selected from the group consisting of tears, aqueous humor, and interstitial fluid.

5. The ophthalmic lens according to any one of claims 1 to 4, wherein the receptor moiety is covalently bound to the ophthalmic lens.

6. The ophthalmic lens according to any one of claims 1 to 5, which comprises a polymer meshwork, wherein pores of the polymer meshwork (a) permit the competitor moiety to bind reversibly to the analyte/competitor moiety binding site and (b) prevent the receptor moiety and the competitor moiety from diffusing out of the ophthalmic lens.

7. The ophthalmic lens according to any one of claims 1 to 6, which comprises:

a receptor moiety layer;
a polyelectrolyte layer; and
a competitor moiety layer.

8. The ophthalmic lens according to any one of claims 1 to 7, wherein the detectable label is a fluorescent label.

9. The ophthalmic lens according to any one of claims 1 to 8 for detecting glucose in an ocular fluid, comprising:

a receptor moiety layer, wherein receptor moieties in the receptor moiety layer comprise glucose/competitor moiety bonding sites:

a first and second polyelectrolyte layer; and
a competitor moiety layer, wherein competitor moieties in the competitor moiety layer comprise detectable labels.

10. The ophthalmic lens of claim 9, wherein the receptor moiety layer comprises concanavalin A molecules.

11. The ophthalmic lens of claim 9 or 10, wherein the competitor moiety layer comprises fluorescein dextran molecules.

12. An analyte sensor system, comprising:

(a) an ophthalmic lens (1) according to any one of claims 1 to 11; and
(b) a detector (5) configured to detect the detectable label.

13. The analyte sensor system according to claim 12, wherein the detector (5) includes a fluorophotometer.

14. The analyte sensor system according to claim 12 or 13, further comprising a transmitter coupled to the detector (5) and configured to transmit to a pump (11) a signal (10) indicating whether the detectable label is detected by the detector, wherein the pump is configured to vary a concentration of the analyte in a body fluid or tissue.

15. The analyte sensor according to claim 14, wherein the transmitter is contained in a personal accessory.

16. The analyte sensor system according to claim 14 or 15, further comprising the pump (11).

17. The analyte sensor system according to any one of claims 14 to 16, wherein the transmitter is further configured to transmit the signal (10) to the pump

- (11) wirelessly.
18. The analyte sensor system according to any one of claims 14 to 17, wherein the analyte is glucose and the body fluid is blood.
19. The analyte sensor system according to any one of claims 14 to 18, wherein the pump (11) is an insulin pump.
20. The analyte sensor system according to claim 12, comprising
- (a) an ophthalmic lens (1) for detecting glucose in an ocular fluid, comprising:
- a receptor moiety which comprises an analyte/competitor moiety binding site and a competitor moiety comprising a detectable label, wherein the receptor moiety is concanavalin A and the competitor moiety comprising a detectable label is fluorescein dextran;
- (b) a detector (5) configured to detect the detectable label; and
- (c) a transmitter coupled to the detector and configured to transmit to an insulin pump (11) a signal (10) indicating whether the detectable label is detected by the detector, wherein the pump is configured to vary the glucose concentration in blood.
21. The analyte sensor system according to claim 20, further comprising the insulin pump (11).
- zündungsmarker, einem Allergiemarker, einem Lipid, einem Protein, einem Infektionsmarker und einem Metabolit, ausgewählt ist.
- 5 4. Ophthalmische Linse nach einem der Ansprüche 1 bis 3, wobei die Augenflüssigkeit aus der Gruppe, bestehend aus Tränen, Augenkammerwasser und Interstitialflüssigkeit, ausgewählt ist.
- 10 5. Ophthalmische Linse nach einem der Ansprüche 1 bis 4, wobei die Rezeptorkomponente kovalent an die ophthalmische Linse gebunden ist.
- 15 6. Ophthalmische Linse nach einem der Ansprüche 1 bis 5, die ein Polymermaschenwerk umfaßt, wobei die Poren des Polymermaschenwerks (a) es der Konkurrenzkomponente ermöglichen, reversibel an die Analyt/Konkurrenzkomponenten-Bindungsstelle zu binden und (b) verhindern, daß die Rezeptorkomponente und die Konkurrenzkomponente aus der ophthalmischen Linse diffundieren.
- 20 7. Ophthalmische Linse nach einem der Ansprüche 1 bis 6, umfassend:
- eine Rezeptorkomponenten-Schicht;
eine Polyelektrolyt-Schicht; und
eine Konkurrenzkomponenten-Schicht.
- 25 8. Ophthalmische Linse nach einem der Ansprüche 1 bis 7, wobei die nachweisbare Markierung eine fluoreszierende Markierung ist.
- 30 9. Ophthalmische Linse nach einem der Ansprüche 1 bis 8 zum Nachweis von Glucose in einer Augenflüssigkeit, umfassend:
- 35 eine Rezeptorkomponenten-Schicht, wobei die Rezeptorkomponenten in der Rezeptorkomponenten-Schicht Glucose/Konkurrenzkomponenten-Bindungsstellen umfassen;
eine erste und zweite Polyelektrolyt-Schicht; und
eine Konkurrenzkomponenten-Schicht, wobei die Konkurrenzkomponenten in der Konkurrenzkomponenten-Schicht nachweisbare Markierungen umfassen.

Patentansprüche

1. Ophthalmische Linse zum Nachweis eines Analyten in einer Augenflüssigkeit, umfassend:
- eine Rezeptorkomponente, die eine Analyt/Konkurrenzkomponenten-Bindungsstelle umfaßt, und eine Konkurrenzkomponente, die eine nachweisbare Markierung umfaßt.
2. Ophthalmische Linse nach Anspruch 1, die aus der Gruppe, bestehend aus einer Kontaktlinse, einer intraokularen Linse, einer subkonjunktivalen Linse und einer intracomealen Linse, ausgewählt ist.
3. Ophthalmische Linse nach Anspruch 1 oder 2, wobei der Analyt aus der Gruppe, bestehend aus einem Elektrolyten, einem metallischen Element, einem Polypeptidhormon, einer chronisch verabreichten Medikation, einer akut verabreichten Medikation, einem Kleinmolekülhormon, einem Ent-
- 40
- 45
- 50
- 55
10. Ophthalmische Linse nach Anspruch 9, wobei die Rezeptorkomponenten-Schicht Concanavalin A-Moleküle umfaßt.
11. Ophthalmische Linse nach Anspruch 9 oder 10, wobei die Konkurrenzkomponenten-Schicht Fluoresceindextran-Moleküle umfaßt.
12. Analytsensorsystem, umfassend:

- (a) eine ophthalmische Linse (1) nach einem der Ansprüche 1 bis 11; und
 (b) einen Detektor (5), der so konfiguriert ist, daß er die nachweisbare Markierung nachweist.

13. Analytensensorsystem nach Anspruch 12, wobei der Detektor (5) ein Fluorometer umfaßt.
14. Analytensensorsystem nach Anspruch 12 oder 13, ferner umfassend einen Transmitter, der an den Detektor (5) gekoppelt ist, und so konfiguriert ist, daß er ein Signal (10), das anzeigt, ob die nachweisbare Markierung durch den Detektor nachgewiesen wird, zu einer Pumpe (11) überträgt, wobei die Pumpe so konfiguriert ist, daß sie die Konzentration des Analyten in einer Körperflüssigkeit oder einem -gewebe variiert.
15. Analytensensorsystem nach Anspruch 14, wobei der Transmitter in einem persönlichen Zubehör enthalten ist.
16. Analytensensorsystem nach Anspruch 14 oder 15, ferner umfassend die Pumpe (11).
17. Analytensensorsystem nach einem der Ansprüche 14 bis 16, wobei der Transmitter ferner so konfiguriert ist, daß er das Signal (10) zu der Pumpe (11) drahtlos überträgt.
18. Analytensensorsystem nach einem der Ansprüche 14 bis 17, wobei der Analyt Glucose und die Körperflüssigkeit Blut ist.
19. Analytensensorsystem nach einem der Ansprüche 14 bis 18, wobei die Pumpe (11) eine Insulinpumpe ist.
20. Analytensensorsystem nach Anspruch 12, umfassend
- (a) eine ophthalmische Linse (1) zum Nachweis von Glucose in einer Augenflüssigkeit, umfassend: eine Rezeptorkomponente, die eine Analyt/Konkurrenzkomponenten-Bindungsstelle umfaßt, und eine Konkurrenzkomponente, die eine nachweisbare Markierung umfaßt, wobei die Rezeptorkomponente Concanavalin A ist und die Konkurrenzkomponente, die eine nachweisbare Markierung umfaßt, Fluoresceindextran ist;
- (b) einen Detektor (5), der so konfiguriert ist, daß er die nachweisbare Markierung nachweist; und
- (c) einen Transmitter, der an den Detektor gekoppelt ist, und so konfiguriert ist, daß er ein Signal (10), das anzeigt, ob die nachweisbare Markierung durch den Detektor nachgewiesen wird, zu einer Pumpe (11) überträgt, wobei die

Pumpe so konfiguriert ist, daß sie die Glucosekonzentration im Blut variiert.

21. Analytensensorsystem nach Anspruch 20, ferner umfassend die Insulinpumpe (11).

Revendications

1. Lentille ophtalmique permettant de détecter un analyte dans un fluide oculaire, comprenant :
- un groupement récepteur qui comprend un site de liaison de l'analyte et du groupement compétitif, et
- un groupement compétitif comprenant une marque détectable.
2. Lentille ophtalmique selon la revendication 1 sélectionnée à partir du groupe composé d'une lentille de contact, d'une lentille intraoculaire et d'une lentille intracoméenne.
3. Lentille ophtalmique selon la revendication 1 ou 2, **caractérisée en ce que** l'analyte est sélectionnée à partir du groupe composé d'un électrolyte, d'un élément métallique, d'une hormone polypeptide, d'un médicament administré de façon chronique, d'un médicament administré de façon intensive, d'une petite molécule hormonale, d'un indicateur d'inflammation, d'un indicateur d'allergie, d'un lipide, d'une protéine, d'un indicateur d'infection et d'un métabolite.
4. Lentille ophtalmique selon l'une des revendications 1 à 3, **caractérisée en ce que** le fluide oculaire est sélectionné à partir du groupe comprenant les larmes, l'humeur aqueuse et le fluide interstitiel.
5. Lentille ophtalmique selon l'une des revendications 1 à 4, **caractérisée en ce que** le groupement récepteur est lié de façon covalente à la lentille ophtalmique.
6. Lentille ophtalmique selon l'une des revendications 1 à 5 comprenant un système polymère, **caractérisée en ce que** les pores du système polymère
- (a) permettent au groupement compétitif de se lier de façon réversible au site de liaison de l'analyte et du groupement compétitif et
- (b) empêchent le groupement récepteur et le groupement compétitif de se diffuser hors de la lentille ophtalmique.
7. Lentille ophtalmique selon l'une des revendications 1 à 6 comprenant :

- une couche de groupements récepteurs ;
une couche de polyélectrolytes ; et
une couche de groupements compétitifs.
8. Lentille ophtalmique selon l'une des revendications 1 à 7, **caractérisée en ce que** la marque détectable est la marque fluorescente. 5
9. Lentille ophtalmique selon l'une des revendications 1 à 8 permettant de détecter le glucose dans un fluide oculaire, comprenant : 10
- une couche de groupements récepteurs **caractérisée en ce que** les groupements récepteurs de la couche de groupements récepteurs comprennent des sites de liaison du glucose et du groupement compétitif ;
 - une première et une deuxième couche de polyélectrolytes ; et
 - une couche de groupements compétitifs **caractérisée en ce que** les groupements compétitifs de la couche de groupements compétitifs comprennent des marques détectables. 15
10. Lentille ophtalmique selon la revendication 9, **caractérisée en ce que** la couche de groupements récepteurs comprend des molécules de concanavaleine A. 25
11. Lentille ophtalmique selon la revendication 9 ou 10, **caractérisée en ce que** la couche de groupements compétitifs comprend des molécules de dextrane fluorescéine. 30
12. Système de sonde d'analytes comprenant : 35
- (a) une lentille ophtalmique (1) selon l'une des revendications 1 à 11 ; et
 - (b) un détecteur (5) configuré de façon à détecter la marque détectable. 40
13. Système de sonde d'analytes selon la revendication 12, **caractérisé en ce que** le détecteur (5) comprend un fluorophotomètre. 45
14. Système de sonde d'analyte selon la revendication 12 ou 13 comprenant également un transmetteur couplé au détecteur (5) et configuré de façon à transmettre à une pompe (11) un signal (10) indiquant si la marque détectable est détectée par le détecteur, **caractérisé en ce que** la pompe est configurée de façon à faire varier la concentration d'analytes dans un fluide ou un tissu corporel. 50
15. Sonde d'analytes selon la revendication 14, **caractérisée en ce que** le transmetteur est contenu dans un accessoire personnel. 55
16. Système de sonde d'analytes selon la revendication 14 ou 15 comprenant également une pompe (11).
17. Système de sonde d'analytes selon l'une des revendications 14 à 16, **caractérisé en ce que** le transmetteur est également configuré de façon à transmettre, à distance, le signal (10) à la pompe (11).
18. Système de sonde d'analytes selon l'une des revendications 14 à 17, **caractérisé en ce que** l'analyte est le glucose et **en ce que** le fluide corporel est le sang.
19. Système de sonde d'analytes selon l'une des revendications 14 à 18, **caractérisé en ce que** la pompe (11) est une pompe à insuline.
20. Système de sonde d'analytes selon la revendication 12 comprenant : 20
- (a) une lentille ophtalmique (1) permettant de détecter le glucose dans un fluide oculaire comprenant : 25
 - un groupement récepteur qui comprend un site de liaison de l'analyte et du groupement compétitif et un groupement compétitif qui comprend une marque détectable, **caractérisé en ce que** le groupement récepteur est de la concanavaleine A et **en ce que** le groupement compétitif comprend une marque détectable qui est de la dextrane fluorescéine ;
 - (b) un détecteur (5) configuré de façon à détecter la marque détectable ; et
 - (c) un transmetteur couplé au détecteur et configuré de façon à transmettre à une pompe à insuline (11) un signal (10) indiquant si la marque détectable est détectée par le détecteur, **caractérisé en ce que** la pompe est configurée de façon à faire varier la concentration de glucose dans le sang. 30
21. Système de sonde d'analytes selon la revendication 20 comprenant également une pompe à insuline (11).

FIG. 1

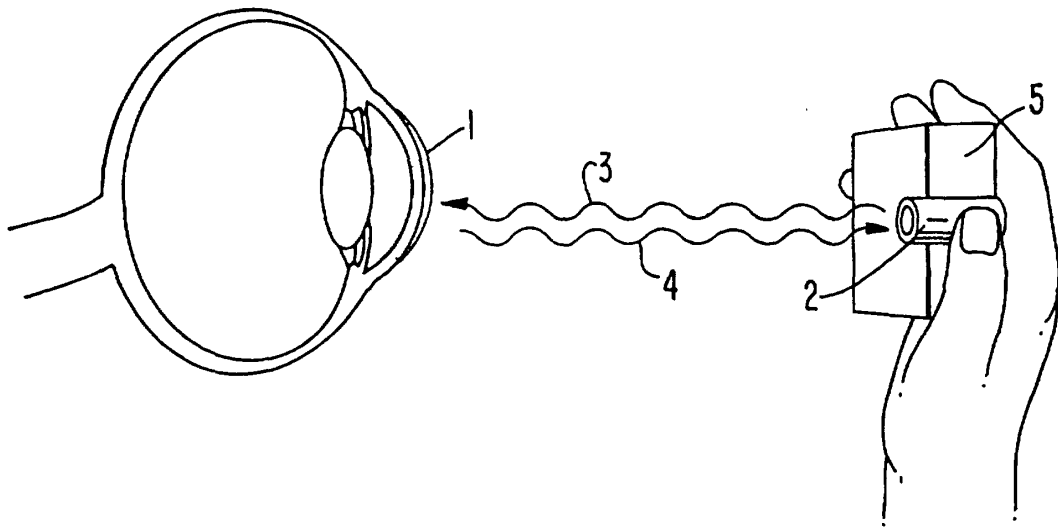

FIG. 3A

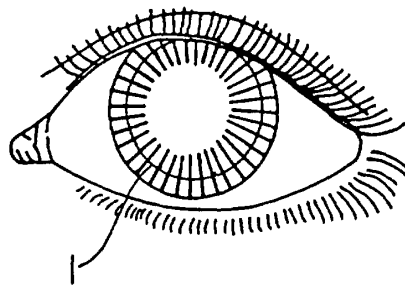

FIG. 3B

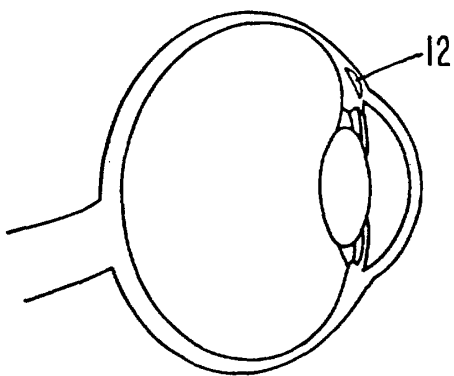

FIG. 3C

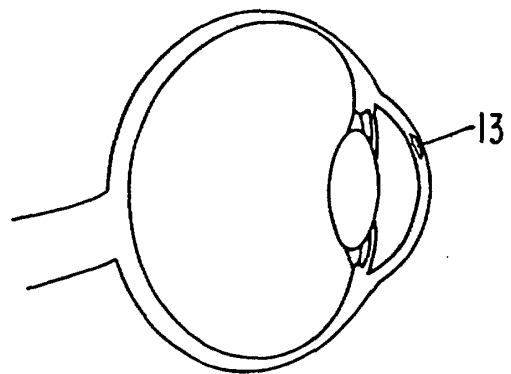

FIG. 2A

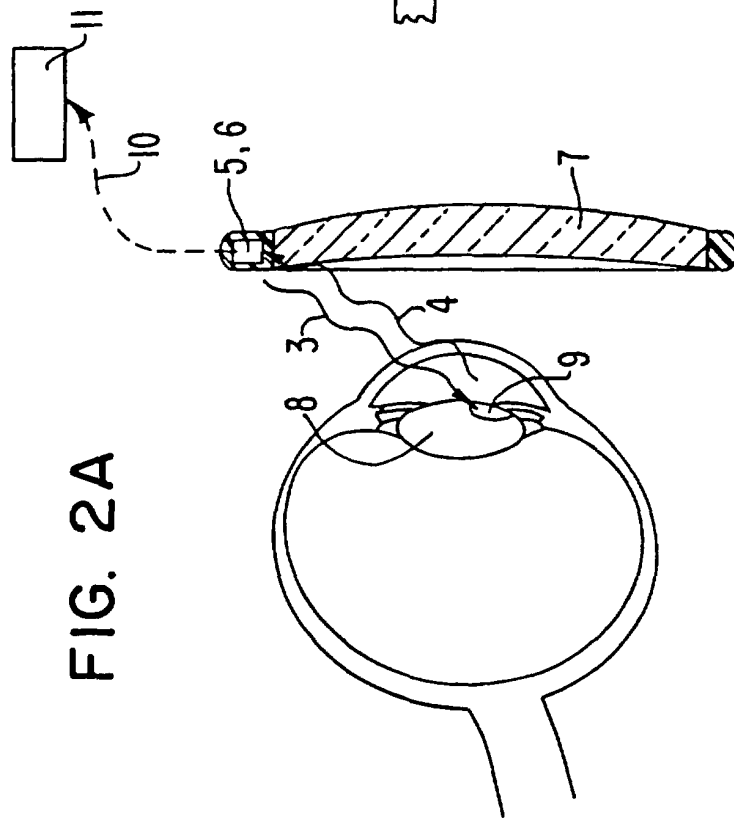
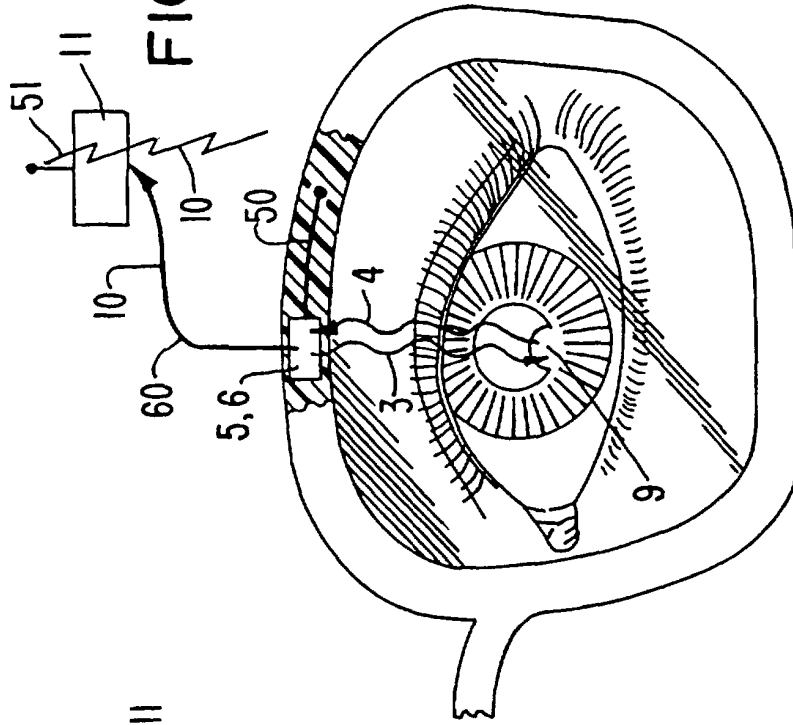

FIG. 2B



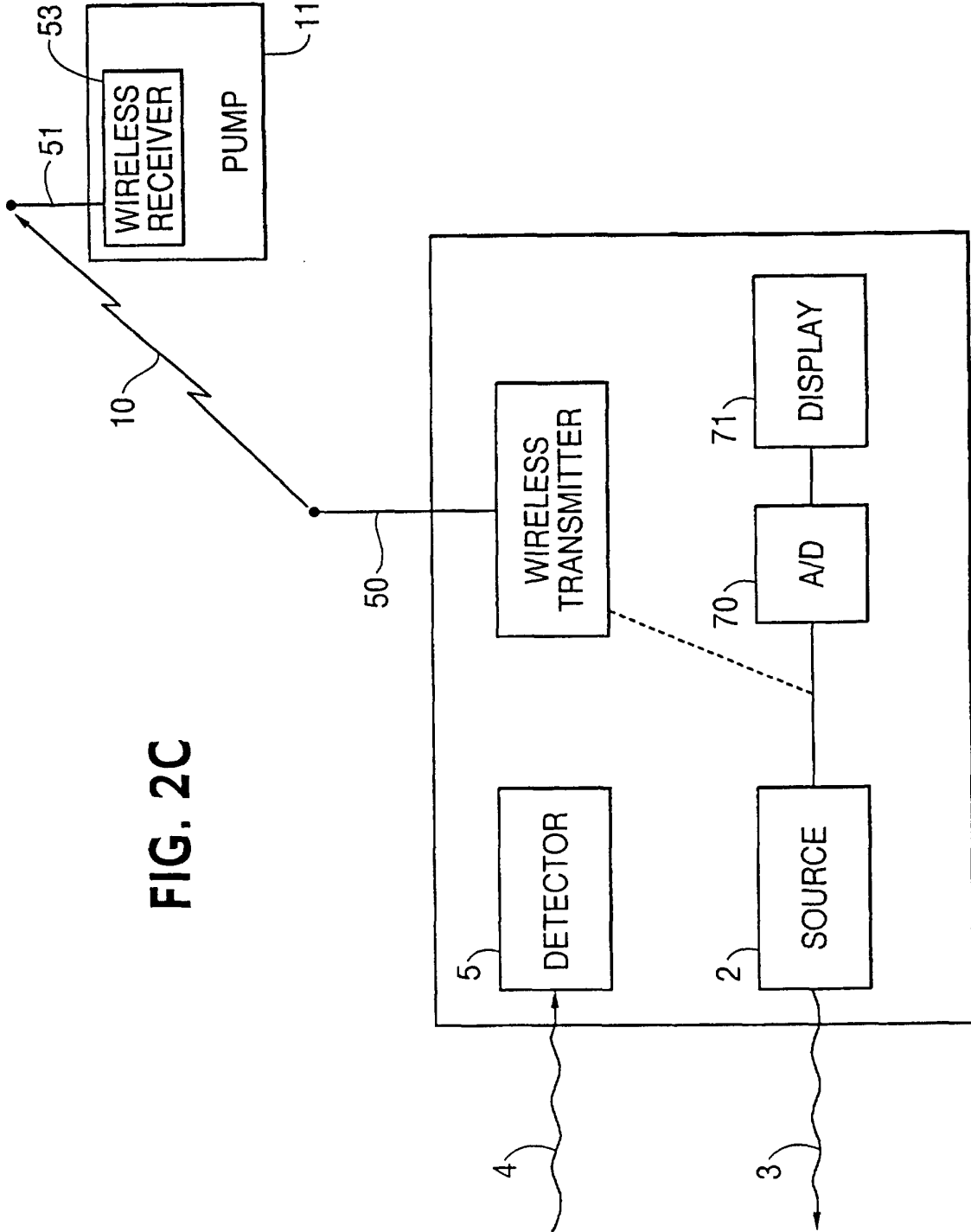
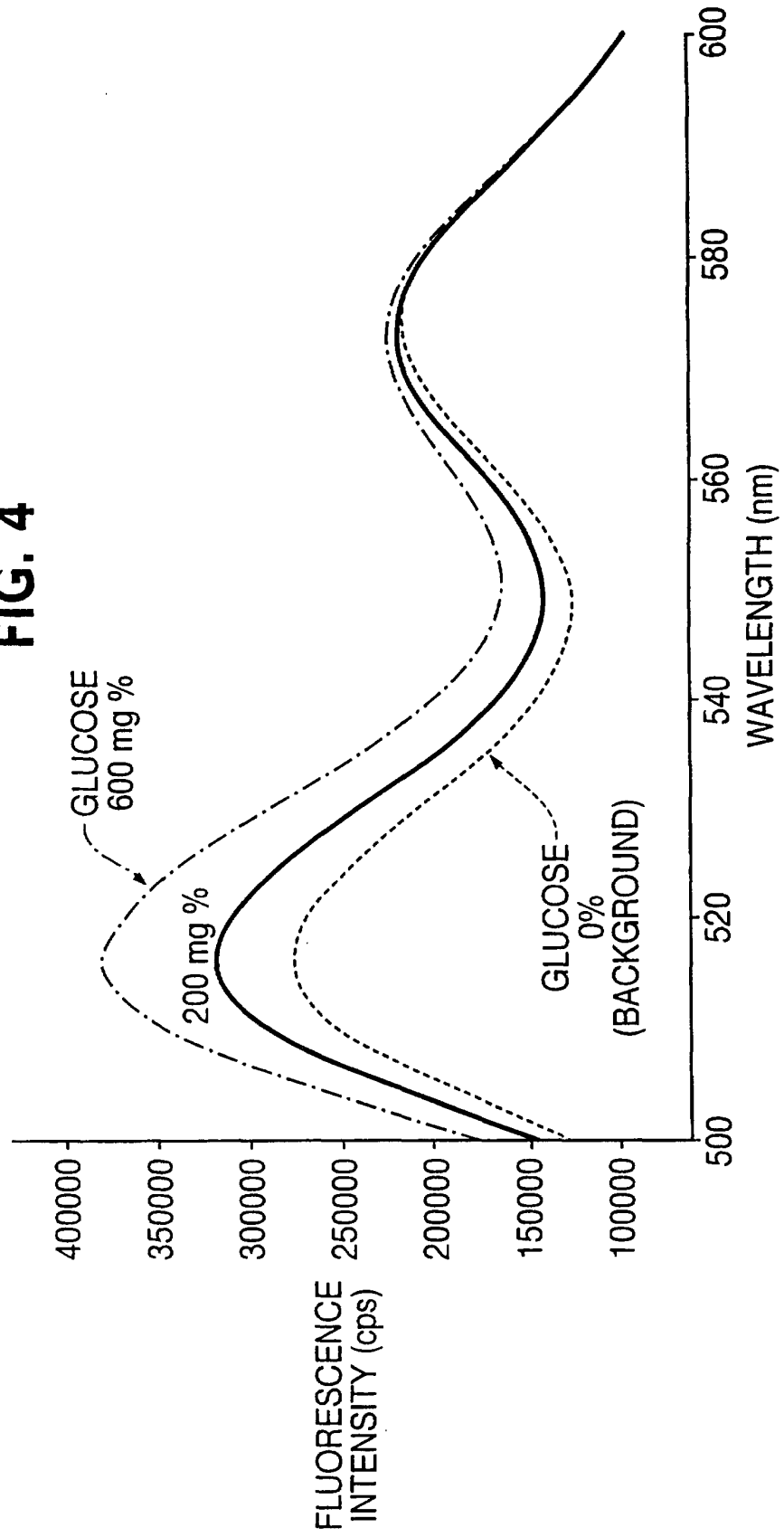

FIG. 2C

FIG. 4



专利名称(译)	眼部分析物传感器		
公开(公告)号	EP1206213B1	公开(公告)日	2005-01-26
申请号	EP2000960520	申请日	2000-08-24
[标]申请(专利权)人(译)	诺瓦提斯公司		
申请(专利权)人(译)	诺华公司		
当前申请(专利权)人(译)	诺华公司		
[标]发明人	MARCH WAYNE FRONT		
发明人	MARCH, WAYNE, FRONT		
IPC分类号	G01N21/64 A61B5/00 G01N33/50 G01N33/543		
CPC分类号	A61B5/1455 A61B5/0002 A61B5/14532 A61B5/411 Y10S977/905		
优先权	60/185980 2000-03-01 US 60/150792 1999-08-26 US		
其他公开文献	EP1206213A1		
外部链接	Espacenet		

摘要(译)

包含受体部分的眼科镜片可用于确定眼液中分析物的量。受体部分可以结合特定分析物或可检测标记的竞争物部分。测量被分析物从受体部分置换的可检测标记的竞争物部分的量，并提供测定眼液中分析物浓度的方法，例如泪液，房水或间质液。眼液中分析物的浓度反过来表示体内流体或组织样品中分析物的浓度，例如血液或细胞内液。

