

(19) World Intellectual Property
Organization
International Bureau



(43) International Publication Date
15 December 2005 (15.12.2005)

PCT

(10) International Publication Number
WO 2005/117690 A1

(51) International Patent Classification⁷: **A61B 5/0215**

(21) International Application Number:
PCT/EP2005/005819

(22) International Filing Date: 26 May 2005 (26.05.2005)

(25) Filing Language: English

(26) Publication Language: English

(30) Priority Data:
1026274 26 May 2004 (26.05.2004) NL

(71) Applicant (for all designated States except US): **MARTIL INSTRUMENTS B.V.** [NL/NL]; Kerkkackers 81, NL-1852 GC Heiloo (NL).

(72) Inventor; and

(75) Inventor/Applicant (for US only): **POP, Gheorghe, Aurel, Marie** [NL/NL]; Burgemeester Knappertlaan 32, NL-3117 BB Schiedam (NL).

(74) Agent: **T JONG, Bastiaan, Jacobus**; Arnold & Siedsma, Sweelinckplein 1, NL-2517 GK The Hague (NL).

(81) Designated States (unless otherwise indicated, for every kind of national protection available): AE, AG, AL, AM,

AT, AU, AZ, BA, BB, BG, BR, BW, BY, BZ, CA, CH, CN, CO, CR, CU, CZ, DE, DK, DM, DZ, EC, EE, EG, ES, FI, GB, GD, GE, GH, GM, HR, HU, ID, IL, IN, IS, JP, KE, KG, KM, KP, KR, KZ, LC, LK, LR, LS, LT, LU, LV, MA, MD, MG, MK, MN, MW, MX, MZ, NA, NG, NI, NO, NZ, OM, PG, PH, PL, PT, RO, RU, SC, SD, SE, SG, SK, SL, SM, SY, TJ, TM, TN, TR, TT, TZ, UA, UG, US, UZ, VC, VN, YU, ZA, ZM, ZW.

(84) Designated States (unless otherwise indicated, for every kind of regional protection available): ARIPO (BW, GH, GM, KE, LS, MW, MZ, NA, SD, SL, SZ, TZ, UG, ZM, ZW), Eurasian (AM, AZ, BY, KG, KZ, MD, RU, TJ, TM), European (AT, BE, BG, CH, CY, CZ, DE, DK, EE, ES, FI, FR, GB, GR, HU, IE, IS, IT, LT, LU, MC, NL, PL, PT, RO, SE, SI, SK, TR), OAPI (BF, BJ, CF, CG, CI, CM, GA, GN, GQ, GW, ML, MR, NE, SN, TD, TG).

Published:

- with international search report
- before the expiration of the time limit for amending the claims and to be republished in the event of receipt of amendments

For two-letter codes and other abbreviations, refer to the "Guidance Notes on Codes and Abbreviations" appearing at the beginning of each regular issue of the PCT Gazette.

(54) Title: CATHETER AND PORTABLE DATA MANAGING DEVICE

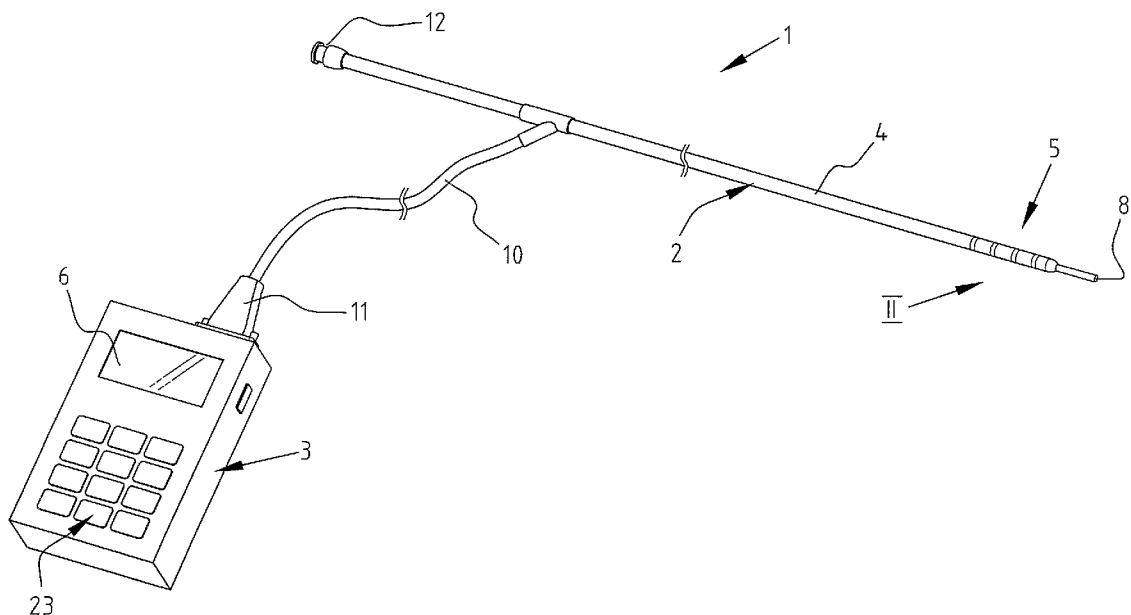

(57) Abstract: The invention relates to an assembly (1) of a catheter (2) and a portable data managing device (3), said catheter having a tubular body (4) with a distal end portion (5) to be introduced into the body of a person and a proximal end portion, said catheter comprising at its distal end portion at least one sensing member (7, 9) and connecting means (10) extending to the proximal end portion for connecting the sensing member to the data managing device, said data managing device comprising control (13) and processing (14) means for controlling the sensing means and processing signals generated thereby.

WO 2005/117690 A1

CATHETER AND PORTABLE DATA MANAGING DEVICE ASSEMBLY

The invention relates to an assembly of a catheter,
5 comprising sensing means and a device for controlling the
sensing means and processing signals generated by the sensing
means.

Assemblies of this kind are known and are for
instance used for determining the pressure inside a blood
10 volume in a patient=s body, or for measuring the impedance of
the blood of the patient in a ventricle of the heart. See
e.g. PCT/NL00/00378.

The device according to the invention as
characterized in claim 1 has the specific advantage that a
15 patient, using this assembly, is not confined to a hospital
bed, but can walk around and more or less follow his or her
daily routines.

In this way, it is possible to monitor the patient for a
considerable longer period of time than would be normally
20 possible when the patient were to be hospitalized.

The portable data managing device of the assembly
according to the invention, can be made small by using the
features of claim 2. The portable data managing device in
that case only contains the most elementary parts and a large
25 part of the data processing can be done by the computer
device.

In a further development the assembly according to
the invention is provided with interfacing means for
interfacing the processing means with a telecommunication
30 device. Relevant data can, in this way, be transmitted to for
instance a doctor, who is treating the patient.

The assembly according to the invention can be used
for a great number of monitoring functions. For example, the

assembly can be designed or comprise means for measuring impedance in a body fluid, for example in a volume of blood. Another possibility is to measure temperatures inside the body of the patient.

5 Furthermore, the measuring of a pressure in a body fluid and the measuring of the concentration of at least one chemical component in a body fluid is possible with the device according to the invention.

10 If the catheter is of the kind to be introduced into the heart of a patient, the sensing means can be designed for measuring the electrical activity of the heart, and can be used for registering a ECG. This feature can also very advantageously be used for positioning the distal end of the catheter in the proper position in the heart by checking the
15 ECG while introducing the catheter.

The invention will be further illustrated in the following description of a preferred embodiment, with a reference to the drawings.

In the drawings,

20 Figure 1 shows a simplified perspective view of the assembly according to the preferred embodiment of the present invention.

Figure 2 shows a detail of figure 1, according to II in figure 1.

25 Figure 3 illustrates the use of the data management device of the assembly according to the invention, together with a portable computer device.

Figure 4 shows a schematic view of the components of the data managing device according to the invention.

30 The assembly shown in figure 1 comprises a catheter 2 and a data managing device 3.

The catheter 2 is provided with a distal portion 5 intended to be introduced in the body of a patient. At the

distal portion 5, the catheter 2 comprises in this embodiment four electrodes 7 and a thermistor 9 as sensing means. Each of these sensing members is connected by connecting means which run through the proximal end of the catheter 2, through 5 the lead 10 to the connector 11, connecting these sensing means with the data managing device 3.

The catheter in this embodiment is provided with one lumen 8 extending from the distal end to the proximal end. At the proximal end a connecting device such as a luer lock is 10 provided for connecting for example a fluid supply to the lumen 8. In this way, fluids such as medicines can be supplied to the body of the patient at the position of the distal end of the catheter. The data managing device can be used also to control and to manage the fluid and medicine 15 supply.

The data managing device 3 is in the embodiment shown, provided with a display screen 6 and a key pad 23. On the display screen 6, instructions and/or measurement data can be shown.

20 The key pad can be used for starting certain functions of the device or, for instance, selecting data to be shown in the display screen 6.

As schematically shown in figure 4, the data managing device of the assembly according to the invention comprises 25 control means 13, for controlling the sensors at the distal end of the catheter. If, for example, the electrodes 7 are used for measuring the impedance in a cavity of the heart of the patient, the control means 13 will be programmed such that an electrical alternating current is generated between 30 two of the electrodes and electrical signals generated thereby in the other two electrodes will be collected and further processed. In this regard reference is made to

PCT/NL00/00378, describing in detail the measuring of impedance with a catheter of this kind.

The data managing device 3 further comprises processing means 14, processing the measurement signals
5 generated by a sensing means.

With the processing means 14, data storage means 21 are connected, for storing measurement data for a certain period of time.

The device 3 is further provided with interfacing
10 means 15 for interfacing with a computer device. As computer device a laptop, desktop or also a palmtop computer can be used. The communication with the computer device can, for instance, be with infra red technology, known as such. In this case the interfacing means 15 are connected with an
15 infra red transmitting and receiving member 16.

As shown in figure 3, the infra red transmitting and receiving means 16 of the data managing device 3 can communicate with infra red transmitting and receiving means 17 of the palmtop computer 20. The palmtop computer 20 will
20 be provided with a program for storing and analysing data received from the data managing device 3 and also for programming the data managing device 3.

The data managing device 3 furthermore can be provided with communication interfacing means 18. These
25 communication interfacing means can for example cooperate with a palmtop 20 provided with a GPS telephone or such.

It is also possible to provide the data managing device 3 as shown in figure 4 with communication interfacing means 18 that contain GSM communication means. The data
30 managing device 3 is provided with an antenna 9, so as to be capable of communicating directly with a remote station, capable of receiving data from the data managing device or

sending instructions to be performed by the data managing device.

It is noted that the assembly according to the invention can be embodied in a great number of ways for a great number of different applications.

5 A more detailed description of the assembly 1, shown in figure 1, is given herein after.

The assembly 1 comprises at least a catheter 2 and a portable data managing device 3. The catheter is designed as a usual central venous catheter, but contains extra features,
10 which enable on-line continuous determination of important characteristics of the heart and blood. To facilitate these extra features the catheter is connected with a portable electronic box, the data managing device 3. The data managing device 3 is an electronic diagnostic and storage device with
15 a small display screen 6. Furthermore, the data managing device 3 can be compatible with any commercially available notebook, palmtop, cellular phone or alike.

As a usual central venous catheter, the catheter 2 has 2 or 3 lumens 8 for administration of medication,
20 nutrients and/or different fluids as well as for central venous pressure measurement. Introduction of the catheter 2 is the same as for the usual central venous catheter by the antebrachial vein or by a jugular or subclavian vein approach. One of the features of the catheter is the presence
25 of 2 or 4 electrodes at the distal end (see Figure 2). These electrodes 7 enable continuous impedance measurement in the blood (see patent application: PCT/NL00/00378) by which precise determination can be obtained of the hematocrit in the blood and blood viscosity can be estimated with help of
30 the data managing device 3. The same electrodes 7 enable continuous on-line registration of the intracavitary ECG signal, which also can be displayed and stored in the data managing device 3. Furthermore, at the distal part 5 of the

catheter 2 a small sensor 9 for continuous on-line measurement of blood temperature is built in and temperature changes within 0.1 Celsius degree are displayed and stored in the data managing device 3.

5 All wires originating from the electrodes 7 at the tip 5 and the distal thermistor 9 are separately shielded, which enables application of electric current frequencies between 20 and 20.000 kHz without significant disturbance by stray capacitance. Despite these extra wires and the 2 or 3
10 lumens, the size of the catheter 2 can be not more than 7 French.

The distal electrodes 7, which register the intracavitary ECG, can also be used as markers of correct positioning of the catheter 2. As soon as the tip 5 of the
15 catheter 2 enters the right atrium the appearance of the intracavitary ECG on the display screen 6 of the data managing device 3 will prevent mal positioning of the catheter 2 inside the right ventricle. The P-wave of the atrial depolarization on the intracavitary ECG should always
20 be larger than the QRS-complex of the ventricular electrical activation. The characteristics of the P-wave are used as indicators for the positioning of the catheter 2. Interpretation of the P-wave prevents the entrance of the catheter 2 in the right ventricle and therefore enhances the
25 possibility to avoid the potential dangerous ventricular arrhythmias that occur when a venous catheter enters the right ventricle.

If necessary, the introduction sheath of the catheter 2 remains positioned at the venous puncture site, where a
30 flexible plastic isolation will cover part of the outside catheter 2. This plastic coverage enables repositioning of the catheter 2 under still sterile conditions, if necessary.

The data managing device 3 is specially designed as a portable device for connection between the catheter 2 and any commercially available notebook, palmtop 20, cellular phone or alike. Dimensions of the data managing device 3 enable
5 positioning thereof in a small pocket in the pyjama of a patient. The data managing device 3 is able to produce electrical currents at frequencies between 20 and 20.000 kHz as a sweep or as different sequential frequencies. Impedance values such as electrical resistivity and capacitance are
10 displayed on the small screen 6 and can be stored. In order to measure impedance values in similar conditions of blood flow, the impedance can be measured by means of a repetitive mechanism of stimulate-and-sense signals with measuring intervals between 8 and 20 mS. The impedance measurements can
15 be triggered on the intracavitary ECG signal, which is determined simultaneously. In case of a complete frequency sweep, the final result will be calculated during several cardiac cycles.

The data managing device 3 contains acoustic and
20 optic alarm-systems, which alert the non-experienced user when heart rhythm, intracavitary ventricular ECG-signals, temperature or special blood characteristics surpass certain limits. These limits can be adapted and are displayed on the screen 6. Also an alarm will start as soon as the batteries
25 are low. In order to minimize the dimensions and the battery power of the data managing device, preferably the data managing device is not designed for data storage of longer than 24-36 hours. The idea of the Data managing device is to play a role as a temporary portable electronic interface
30 between heart and blood on one side and a hand-held computer on the other side. Within 24-36 hours the data in the data managing device should be downloaded on a hand held computer 20 and this downloading is so user-friendly, that all

patients can manage. The hand held computer 20 will give full digital disclosure and analysis of the actual data of a patient and can compare these data with former information of the patient, if necessary with information of a year ago. In fact, the hand held computer 20 will contain the patient dossier in an electronic form. By a wired line or by WAP-technology physicians or other health care workers can download the information they want for their daily or weekly patient care. The downloaded information from the hand-held computer 20 may also digitally be sent to the doctor by phone or by internet (tele-medicine).

The thermistor 9 at the distal end of the catheter 2 will register fever or subfebril temperature. This will alert the patient to see the doctor, not only for possible new disease or exacerbation of an existing disease, but also to check whether the catheter itself has become infected and should be withdrawn. However, the thermistor 9 can also be used to guide cooling therapy, which is currently being used in intensive care units after successful resuscitations in order to reduce brain damage.

Preferably, the data managing device 3 has a special feature that can be connected with a portable injection system. These portable injection systems are already commercially available and are used in ambulatory patients in the hospital or at home for periodic drug and/or liquid administration. The data managing device 3 will be able to monitor the time-intervals at which periodically automatic treatment is given and an alarm will start as soon as too long or too short administration of liquids and/or drugs has been given.

Another favourable feature is the connection of the data managing device 3 with a non-invasive blood pressure measurement system; the pressure data can also be stored in

the data managing device and be combined with the other parameters of the heart and blood, determined at the same time.

Permanent software upgrading of the data managing device 3 is possible and is meant to amplify its role as a temporary portable electronic interface between heart and blood and a hand-held computer. Having access to blood any time through the catheter 2, sophisticated analysis by chemical chips may be introduced in the data managing device 3 for determination of glucose, CRP, anticoagulation level, etc. Again the data can be analysed immediately and the screen display 6 will show the result and the normal limits; if necessary, the patient may contact a health worker or the data will be stored and downloaded afterwards in the hand-held computer 20.

Having mentioned the several special and preferred features of the catheter and the data managing device according to the invention, one can imagine which applications this assembly may have. Because of the accurate monitoring possibilities of this assembly, chronic patients may be dismissed from hospital earlier and may need to come back to hospital only for special diagnostic procedures such as MRI or CT-scan, etc. Chronic patients who need special care may be treated by home nurses, who can read out the electronic patient dossier and discuss the results with the doctors in hospital by internet. Because of the electronics, dimensions of the data managing device 3 are tiny and will almost not interfere with the daily activities of the patient. For example the intracavitary ECG detection will avoid the use of several external electrodes.

In the Western World millions of people suffer from chronic heart failure and repetitive hospitalizations are often necessary; as people become older heart failure will

even become more prevalent. Hospitalizations may be prevented if medical treatment and adequate monitoring at home will become available. Often intravenous medical therapy is needed in these patients and with the catheter and data managing device intravenous drug administration, as well as central venous filling pressure besides on-line monitoring of different cardiac and blood parameters will be possible. Home nursing is preferred by most patients and health care costs will be reduced by reduction of hospitalizations. The catheter and data managing device can be positioned in a Portocath-device, which is meant to remain intravenously for several months.

In the hospital itself, the combined use of the catheter and the data managing device may be useful especially, when patients are transported from intensive care units to radiology departments for diagnostic procedures. No extensive monitoring systems have to be taken with the patient.

A catheter of the assembly according to the invention, with less extra features may be used as just a peripheral venous line, while it still may be connected with the data managing device, for example for only monitoring of drug and/or fluid administration and for instant analysis of blood by micro-chip technique.

The unique concept of combining a catheter with an electronic interface may also be used for urinary tract catheters.

CLAIMS

1. Assembly 1 of a catheter 2 and a portable data managing device 3, said catheter having a tubular body 4 with
5 a distal end portion 5 to be introduced into the body of a person and a proximal end portion, said catheter 2 comprising at its distal end portion 5 at least one sensing member 7,9 and connecting means 10 extending to the proximal end portion for connecting the sensing member 7,9 to the data managing
10 device 3, said data managing device comprising control 13 and processing 14 means for controlling the sensing means 7,9 and processing signals generated thereby.

2. The assembly of claim 1 comprising computer interfacing means 15 for interfacing the processing means 14
15 with a computer device 20.

3. The assembly of claim 1 comprising communication interfacing means 18 for interfacing the processing means 14 with a telecommunication device.

4. The assembly of claim 3, wherein the communication
20 18 means are incorporated in the data managing device 3.

5. The assembly of claim 1, wherein the sensing member 7 and the control 13 and processing 14 means are designed for measuring impedance in a body fluid.

6. The assembly of claim 1, wherein the sensing
25 member 9 and the control 13 and processing 14 means are designed for measuring temperature.

7. The assembly of claim 1, wherein the sensing member and the control 13 and processing 14 means are designed for measuring pressure in a body fluid.

30 8. The assembly of claim 1, wherein the sensing member and the control and processing means are designed for measuring the concentration of at least one chemical component in a body fluid.

9. The assembly of claim 1, wherein the sensing member 7 and the control 13 and processing 14 means are designed for measuring electrical tension.

10. The assembly of one of the claims 5 - 9, wherein the sensing member 7 and the control 13 and processing 14 means are designed for measuring in a blood volume in a person's body.

11. The assembly of claim 1 wherein the data managing device 3 comprises data storage means 21 for storing measurement signals or processed data.

12. The assembly of claim 1, wherein the data managing device 3 comprises alarm means 22.

13. The assembly of claim 12, wherein the data managing device 3 is programmed such that the alarm means 22 are activated in case a measured or processed signal obtains a preset critical value.

14. The assembly of claim 12, comprising a battery as power supply for the data managing device, wherein said device is programmed such that the alarm means 22 are activated in case the battery is depleted to a predefined extent.

15. The assembly of claim 1, wherein the data management device 3 comprises display means 6 and is programmed such that relevant information referring to the measured or processed signals can be displayed by the display means 6.

16. The assembly of claim 1 further comprising injecting means having an injection fluid supply and supply means connected with a lumen 8 in the catheter, and wherein the data managing means are programmed such that the supply means are activated in response to the magnitude of the measured or processed signals.

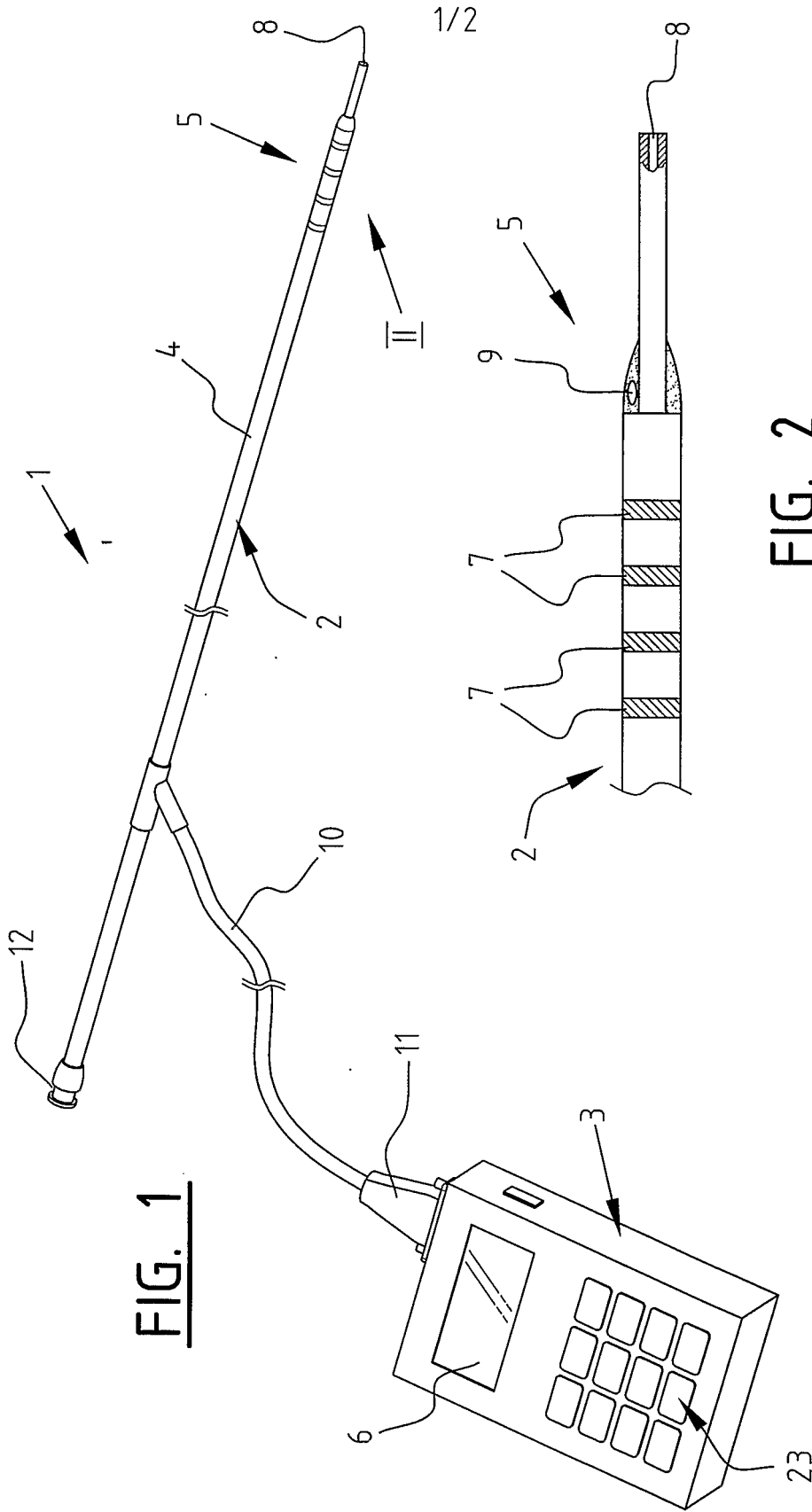

FIG. 1

FIG. 2

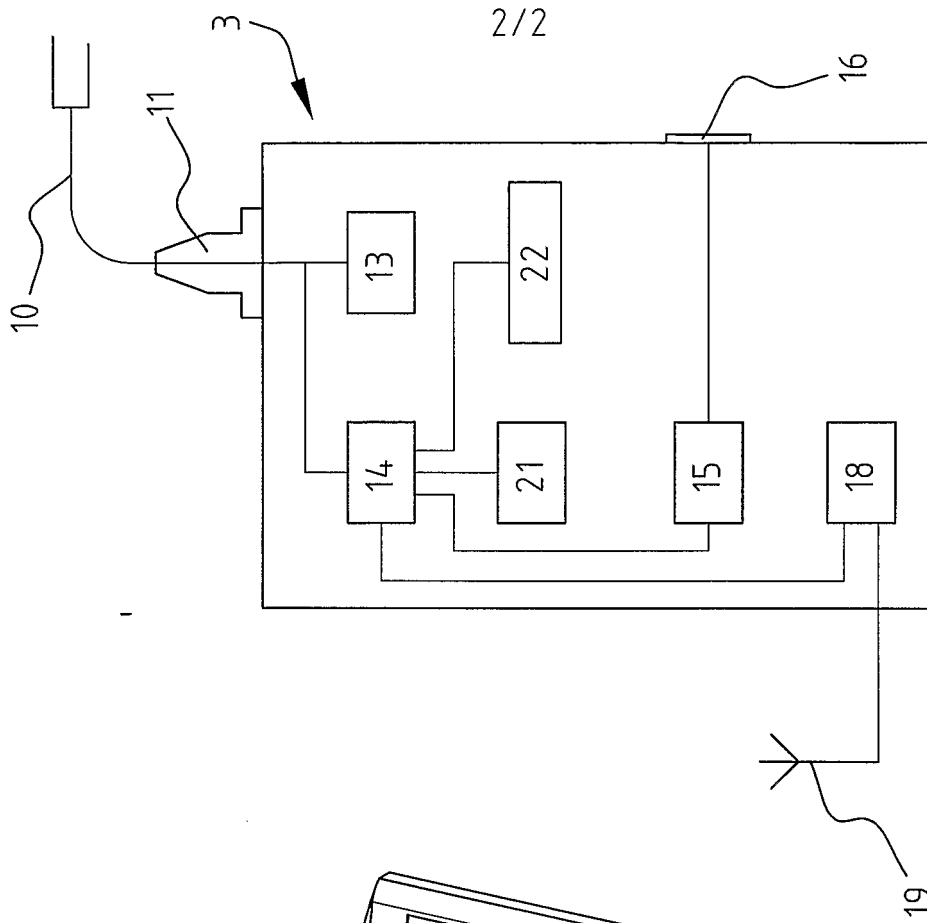

FIG. 4

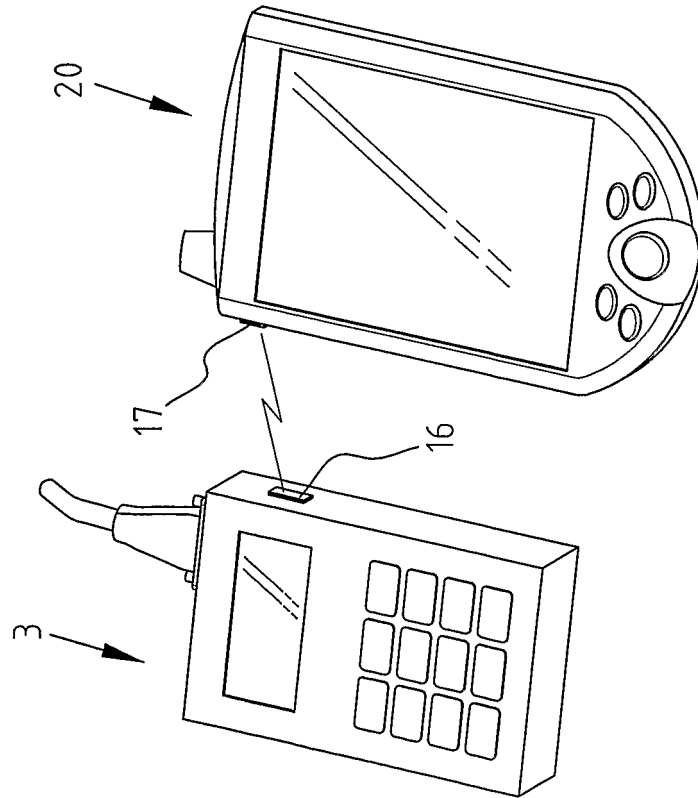

FIG. 3

INTERNATIONAL SEARCH REPORT

International Application No
PCT/EP2005/005819

A. CLASSIFICATION OF SUBJECT MATTER
IPC 7 A61B5/0215

According to International Patent Classification (IPC) or to both national classification and IPC

B. FIELDS SEARCHED

Minimum documentation searched (classification system followed by classification symbols)
IPC 7 A61B

Documentation searched other than minimum documentation to the extent that such documents are included in the fields searched

Electronic data base consulted during the international search (name of data base and, where practical, search terms used)

EPO-Internal, WPI Data, PAJ

C. DOCUMENTS CONSIDERED TO BE RELEVANT

Category *	Citation of document, with indication, where appropriate, of the relevant passages	Relevant to claim No.
X	US 2001/053882 A1 (HADDOCK THOMAS F ET AL) 20 December 2001 (2001-12-20)	1-4, 6, 11-15
Y	paragraph '0064!; figure 5	5, 7-10, 16
Y	US 5 526 820 A (KHOURY ET AL) 18 June 1996 (1996-06-18) abstract; figure 1	7
Y	EP 0 485 118 A (PURITAN-BENNETT CORPORATION) 13 May 1992 (1992-05-13) column 3, paragraph 3 - column 4, paragraph 1; figure 1	8, 10
Y	EP 1 151 720 A (DAHL, ROGER; SAVAGE, STEVEN) 7 November 2001 (2001-11-07) abstract; figure 1	9
	-/--	

Further documents are listed in the continuation of box C.

Patent family members are listed in annex.

* Special categories of cited documents:

- *A* document defining the general state of the art which is not considered to be of particular relevance
- *E* earlier document but published on or after the international filing date
- *L* document which may throw doubts on priority claim(s) or which is cited to establish the publication date of another citation or other special reason (as specified)
- *O* document referring to an oral disclosure, use, exhibition or other means
- *P* document published prior to the international filing date but later than the priority date claimed

- *T* later document published after the international filing date or priority date and not in conflict with the application but cited to understand the principle or theory underlying the invention
- *X* document of particular relevance; the claimed invention cannot be considered novel or cannot be considered to involve an inventive step when the document is taken alone
- *Y* document of particular relevance; the claimed invention cannot be considered to involve an inventive step when the document is combined with one or more other such documents, such combination being obvious to a person skilled in the art.
- *Z* document member of the same patent family

Date of the actual completion of the international search

21 September 2005

Date of mailing of the international search report

06/10/2005

Name and mailing address of the ISA

European Patent Office, P.B. 5618 Patentlaan 2
NL - 2280 HV Rijswijk
Tel. (+31-70) 340-2040, Tx. 31 651 epo nl,
Fax: (+31-70) 340-3016

Authorized officer

Edward, V

INTERNATIONAL SEARCH REPORT

International Application No
PCT/EP2005/005819

C.(Continuation) DOCUMENTS CONSIDERED TO BE RELEVANT		
Category °	Citation of document, with indication, where appropriate, of the relevant passages	Relevant to claim No.
Y	US 2004/010229 A1 (HOUDE ERIC ET AL) 15 January 2004 (2004-01-15) paragraph '0024! -----	16
Y	PATENT ABSTRACTS OF JAPAN vol. 016, no. 180 (C-0935), 30 April 1992 (1992-04-30) & JP 04 022370 A (OLYMPUS OPTICAL CO LTD), 27 January 1992 (1992-01-27) abstract -----	5
X	US 2002/156417 A1 (RICH COLLIN A ET AL) 24 October 2002 (2002-10-24) paragraph '0028! - paragraph '0029!; figure 3 -----	1

INTERNATIONAL SEARCH REPORT

Information on patent family members

International Application No

PCT/EP2005/005819

Patent document cited in search report	Publication date	Patent family member(s)	Publication date
US 2001053882 A1	20-12-2001	AU 7359701 A	24-12-2001
		CA 2411941 A1	20-12-2001
		EP 1294275 A2	26-03-2003
		JP 2005515795 T	02-06-2005
		WO 0195787 A2	20-12-2001
US 5526820 A	18-06-1996	AU 3719095 A	09-04-1996
		WO 9608993 A1	28-03-1996
EP 0485118 A	13-05-1992	CA 2053447 A1	09-05-1992
		JP 5184557 A	27-07-1993
EP 1151720 A	07-11-2001	JP 2002045344 A	12-02-2002
		US 6496712 B1	17-12-2002
US 2004010229 A1	15-01-2004	AU 2003261125 A1	02-02-2004
		CA 2487496 A1	22-01-2004
		EP 1521606 A1	13-04-2005
		WO 2004006994 A1	22-01-2004
JP 04022370 A	27-01-1992	NONE	
US 2002156417 A1	24-10-2002	NONE	

专利名称(译)	导管和便携式数据管理设备组件		
公开(公告)号	EP1758501A1	公开(公告)日	2007-03-07
申请号	EP2005753144	申请日	2005-05-26
[标]申请(专利权)人(译)	迈尔提勒INSTR		
申请(专利权)人(译)	martil仪器有限公司		
当前申请(专利权)人(译)	martil仪器有限公司		
[标]发明人	POP GHEORGHE AUREL MARIE		
发明人	POP, GHEORGHE, AUREL, MARIE		
IPC分类号	A61B5/0215 A61B5/00 A61B5/0205 A61B5/042 A61B5/053		
CPC分类号	A61B5/0538 A61B5/0017 A61B5/02055 A61B5/02152 A61B5/0422 A61B5/053 A61B5/14532 A61B5/14546 A61B5/7285 A61B2560/045		
优先权	1026274 2004-05-26 NL		
外部链接	Espacenet		

摘要(译)

本发明涉及导管(2)的组件(1)和便携式数据管理装置(3),所述导管具有管状主体(4),所述管状主体(4)具有将被引入到主体中的远端部分(5)。人和近端部分,所述导管在其远端部分包括至少一个传感构件(7,9)和延伸到近端部分的连接装置(10),用于将传感构件连接到数据管理装置,所述数据包括控制(13)和处理(14)的管理装置用于控制传感装置和处理由此产生的信号的装置。