

(19) World Intellectual Property Organization  
International Bureau



(43) International Publication Date  
9 December 2004 (09.12.2004)

PCT

(10) International Publication Number  
**WO 2004/105637 A2**

- (51) International Patent Classification<sup>7</sup>: **A61F**
- (21) International Application Number: PCT/US2004/016500
- (22) International Filing Date: 26 May 2004 (26.05.2004)
- (25) Filing Language: English
- (26) Publication Language: English
- (30) Priority Data: 10/445,723 27 May 2003 (27.05.2003) US
- (72) Inventors: **BROWN, Peter, S.**; 795 Marion Avenue, Palo Alto, CA 94303 (US). **KOVAC, Tim**; 27 Ashler Avenue, Los Gatos, CA 95030 (US). **WEI, Michael**; 124 Buckthorn Way, Apt. 3, Menlo Park, CA 94025 (US). **ECKERT, Robin, W.**; 109 Rhodes Court, San Jose, CA 95126 (US).
- (74) Agents: **HANLEY, John, V.** et al.; Fulwider Patton Lee & Utecht, LLP, Howard Hughes Center, 10th Floor, 6060 Center Drive, Los Angeles, CA 90045 (US).
- (81) Designated States (unless otherwise indicated, for every kind of national protection available): AE, AG, AL, AM, AT, AU, AZ, BA, BB, BG, BR, BW, BY, BZ, CA, CH, CN, CO, CR, CU, CZ, DE, DK, DM, DZ, EC, EE, EG, ES, FI, GB, GD, GE, GH, GM, HR, HU, ID, IL, IN, IS, JP, KE, KG, KP, KR, KZ, LC, LK, LR, LS, LT, LU, LV, MA, MD, MG, MK, MN, MW, MX, MZ, NA, NI, NO, NZ, OM, PG, PH, PL, PT, RO, RU, SC, SD, SE, SG, SK, SL, SY, TJ, TM,
- (71) Applicant (for all designated States except US): **ENDO VASCULAR TECHNOLOGIES, INC.** [US/US]; 3200 Lakesie Drive, S444, Santa Clara, CA 95054 (US).

[Continued on next page]

(54) Title: ENDOVASCULAR GRAFT WITH SEPARABLE SENSORS

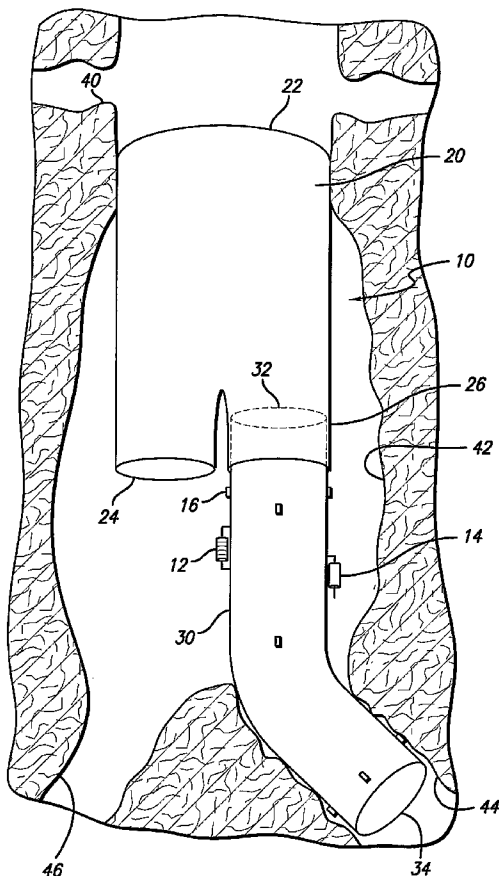

(57) Abstract: A endovascular graft having sensing devices attached thereto to facilitate measurement of pertinent parameters within the vasculature into which the graft is implanted. Power sources and transmitters may be attached to the graft to facilitate transmission of measurements to a receiving device outside the patient's body. The sensing devices, may be electrically passive or integrated devices with measurement and transmission capability. The sensing devices may be attached to specific locations on the graft material or attached to the lumen, thereby providing pertinent parameters from critical points inside the vasculature, or may be dispersed over the surface of the graft material or within the lumen to provide a profile of pertinent parameters. The sensing devices may be attached to the graft material with one suture using a running stitch to minimize graft bulk and may be coated with a material to inhibit or control tissue growth. A bio-absorbable or hard wire tether or suture may be employed to attach devices to one or more graft components.

WO 2004/105637 A2



TN, TR, TT, TZ, UA, UG, US, UZ, VC, VN, YU, ZA, ZM, ZW.

SK, TR), OAPI (BF, BJ, CF, CG, CI, CM, GA, GN, GQ, GW, ML, MR, NE, SN, TD, TG).

**(84) Designated States** (*unless otherwise indicated, for every kind of regional protection available*): ARIPO (BW, GH, GM, KE, LS, MW, MZ, NA, SD, SL, SZ, TZ, UG, ZM, ZW), Eurasian (AM, AZ, BY, KG, KZ, MD, RU, TJ, TM), European (AT, BE, BG, CH, CY, CZ, DE, DK, EE, ES, FI, FR, GB, GR, HU, IE, IT, LU, MC, NL, PL, PT, RO, SE, SI,

**Published:**

— *without international search report and to be republished upon receipt of that report*

*For two-letter codes and other abbreviations, refer to the "Guidance Notes on Codes and Abbreviations" appearing at the beginning of each regular issue of the PCT Gazette.*

ENDOVASCULAR GRAFT WITH SEPARABLE SENSORS

This application is a continuation-in-part of U.S. Application No. 10/165,763, filed June 7, 2002.

BACKGROUND OF THE INVENTION

5 This invention relates to the treatment of body lumens and, more particularly, to the endovascular placement of a prosthetic graft within vasculature for the purpose of repairing the same.

Ruptured abdominal aortic aneurysms (AAA) are a leading cause of death in the United States. Treatment options to repair AAA include conventional open  
10 surgery and implantation of an endovascular graft. Conventional open surgical repair of AAA involves major abdominal surgery with associated high rates of morbidity. Endovascular grafts have been developed to endoluminally bypass abdominal aortic aneurysms through minimally invasive surgery. Many patients that are unacceptable surgical risks for open repairs are eligible for endovascular  
15 graft implantation. Deployment of transfemoral, endovascular grafts to treat AAA is appealing for many reasons: avoidance of an abdominal incision, lack of aortic cross clamping, the potential for regional anesthesia, and a shortened hospital stay.

Untreated AAA have been shown to continue to expand until rupture, with an associated high mortality rate. Implantation of endovascular grafts have also  
20 been associated with high complication rates, including perioperative death, conversion to open repair, the need for further intervention, the need for hemodialysis, a failure to cure the AAA, and wound complications.

The inability to obtain or maintain a secure seal between the vessel wall and the endovascular graft is a complication unique to endovascular aneurysm  
25 exclusion. Because the term "leak" has been associated with aneurysm rupture following conventional surgery, the term "endoleak" has been proposed as a more definitive description of this complication. It is believed that persistent endoleaks result in continued aneurysm expansion, which may eventually lead to aneurysm rupture. Aneurysms that have been successfully excluded have shown a tendency  
30 towards a reduction in aneurysm diameter. Failure to properly exclude the

aneurysm from systemic arterial blood pressure keeps the patient at risk of impending rupture. Endoleaks have been classified according to the source of the leaks. Current classifications of endoleaks include four categories. Type I endoleaks are “perigraft” or “graft-related” leaks that involve a persistent channel  
5 of blood flow due to inadequate or ineffective sealing at the ends of the endovascular graft, or between overlapping components of a modular system. Type II endoleaks are retrograde flow into the aneurysm sac from patent lumbar arteries, the inferior mesenteric artery, or other collateral vessels. Type III endoleaks result from fabric tears, graft disconnection, or graft disintegration. Finally, Type IV  
10 endoleaks are flow through the graft fabric associated with graft wall porosity or permeability. It has been recognized that preoperative patent side branches are not a good predictor of postoperative endoleaks.

There have been a number of reported cases of aneurysm rupture following implantation of an endovascular graft. Some of the ruptures occurred in patients  
15 without a documented endoleak.

A number of studies have focused on measurement of pressure within the aneurysm sac following implantation of an endovascular graft, both in the human patient, an animal model, or an in vitro model. Properly implanted endovascular grafts have been shown to reduce the pressure within the aneurysm sac while an  
20 endoleak, with or without detectable blood flow, continues to pressurize the sac at pressures equivalent to the systemic arterial pressure. Animal studies utilizing a predictable rupturing aneurysm model have shown that non-excluded aneurysms will rupture. Thrombosed aneurysm sacs may still receive pressurization from a sealed endoleak and this continued pressurization keeps the aneurysm at risk for  
25 rupture.

Current methods of patient follow-up include arteriography, contrast-enhanced spiral computed tomography (CT), duplex ultrasonography, abdominal X-ray, and intravascular ultrasound. All of these methods are costly and involve  
30 invasive procedures with associated morbidity that may need to be performed in a hospital. None of the imaging methods are completely successful in detecting endoleaks. Therefore, the potential exists for an endoleak to go undetected until

eventual rupture. An increase in aneurysm diameter is detectable, and should be considered an indication of endoleak. To avoid aneurysm rupture an increase in aneurysm diameter must be detected in a timely fashion to identify patients in need of corrective endovascular procedures.

5 An endovascular graft with the ability to measure pressure within the aneurysm sac and provide feedback to the physician could provide acute confirmation of a procedure and identify those patients with persistent pressurization of their aneurysm, and subsequent risk of rupture. Some physicians are advocating that the follow-up examinations of AAA patients focus on pressure  
10 measurements, but that this is not currently clinically feasible. Furthermore, follow-up examinations may be performed in the physician's office as opposed to a hospital. Moreover, clinicians will have a new method to study the pathology of post-endovascularly treated AAA disease.

Accordingly, there exists a need for an endovascular graft that facilitates  
15 non-invasive measurement of pressure, as well as other pertinent parameters, within the aneurysm sac and along the endovascular graft itself as a means for confirming the success of a procedure as well as identifying patients at risk for aneurysm rupture after the endovascular graft is implanted.

However, providing devices on an endovascular graft to facilitate the  
20 measurement of pertinent parameters poses problems. The measurement device increases bulk, which can significantly effect the delivery profile of the endovascular graft and increase the force necessary to deploy the device, such as jacket or release wire retraction forces. Increased bulk is a significant issue for an endovascular graft. Furthermore, attachment of measurement devices to an  
25 endovascular graft may require sutures and the suture knots not only provide increased bulk, but are also potential graft wear points. Additionally, tissue growth around a measuring device attached to an implanted endovascular graft may interfere with its function and inaccurate data may result. The present invention addresses these problems and other needs.

### SUMMARY OF THE INVENTION

Briefly and in general terms, the present invention is embodied in an endovascular graft with sensors attached thereto. The endovascular graft has the ability to be delivered endovascularly and measure pertinent parameters within the lumen in which it is implanted. The endovascular graft has the ability to transmit data about intra-lumen parameters to an external monitoring device. Confirmation of a successful implant procedure is quickly and easily obtained. Patient follow-up is less costly (conducted in the physician office), non-invasive, and more accurate, allowing prompt intervention in those patients most at risk for acute AAA rupture. The invention would also allow for more frequent patient follow-up, increasing the potential to diagnose and treat aneurysms at risk before acute rupture.

In one aspect of the invention, a modular endovascular graft having a main body component and one or more limb components is provided. One or more sensors are attached to the limb component(s). By attaching at least one sensor near the superior end of the limb component and sizing the main body component such that the sensor is adjacent to the aneurysm sac when the endovascular graft is implanted, measurement of pertinent parameters within the aneurysm sac is facilitated. The meaning of the term "adjacent" as used herein encompasses the sensor being located within the aneurysm sac or at a location where the parameters or properties being detected indicate conditions within the aneurysm sac. Measurements of pertinent parameters within the aneurysm sac may allow early confirmation of a successful procedure and identification of areas of the patient's vasculature at risk for aneurysm rupture, thrombus formation, infection, inflammation or other anomalies without the need for invasive procedures.

An antenna or other data transmitter and a power source also may be attached to the limb component adjacent to the aneurysm sac, allowing a physician or technician to monitor graft and vessel health without the need for an invasive procedure. The transmitter transmits measurements made by the sensors to a receiver located outside the patient's body. With the main body component unencumbered with sensors, transmitters or power sources, the bulk of the main

body component is minimized and thereby, catheter diameter, jacket retraction and deployment complications are kept to a minimum.

In another aspect of the invention, an endovascular graft is provided that has attached thereto at least one integrated sensor/transmitter device capable of  
5 measuring a pertinent parameter and transmitting the measurements to an external monitoring device. Although having more bulk than a sensor, the integrated sensor/transmitter device has less total bulk than a sensor and independent transmitter device, thereby facilitating less total bulk for the endovascular graft.

Furthermore, the integrated sensor/transmitter device may be designed to  
10 allow one or more "satellite" sensors, having no function other than measurement, to be connected thereto. A single integrated sensor/transmitter device and smaller "satellite" sensors facilitate a smaller total bulk than multiple integrated sensor/transmitter devices. Attaching the integrated sensor/transmitter at a central location such as the graft crotch and "satellite" sensors at various locations on the  
15 endovascular graft facilitates measurement and transmission to an external monitoring device of pertinent parameters at multiple locations along the endovascular graft and within the lumen. The "satellite" sensors allow a complete profile of pertinent parameters to be obtained and may provide more accurate identification of anomalies. Measurement of pertinent parameters at multiple  
20 locations along the endovascular graft or within the aneurysm sac may allow early detection of a defective seal between endovascular graft components, graft wear or changes in aneurysm geometry. The smaller "satellite" sensors may also allow pertinent parameters to be measured from locations on the endovascular graft where local graft bulk is a constraint of the design, such as the graft contra limb or near the  
25 superior attachment system that holds the graft in the patient's aorta.

Additionally, it is contemplated that "satellite" sensors may be attached directly to the lumen of a patient. The integrated sensor/transmitter device also may be attached directly to the lumen or attached to an implanted endovascular graft.

Moreover, it is contemplated that passive devices, or monuments, which  
30 perform no sensing function may be attached to the implanted endovascular graft or directly attached to the aneurysm sac. By tracking the location of the monuments

with a monitoring device, changes in the position of the endovascular graft within the lumen or changes in the geometry of the tissue outside the endovascular graft may be detected without the problems of encapsulation or thrombus isolation associated with the measurement of pertinent parameters. Such changes may provide early detection of endovascular graft displacement or aneurysm re-dilation due to an endoleak.

Sensors with pressure measurement capability may be used to detect pressure changes in the aneurysm sac indicative of graft failure or endoleak due to an inadequate seal between the endovascular graft and the vasculature. Sensors with temperature measurement capability may be used to detect temperature differentials associated with "hot spots" related to inflammation, infection or thrombus formation in the vessel. Sensors with the capability to measure oxygen and other blood constituents such as enzymes, proteins, and nutrients, may be used to detect minute blood flow indicative of endoleak. Sensors with the capability to measure electrical potential or magnetic fields may be used to detect differences in potential associated with areas of the vessel at risk for thrombus formation. Sensors also may be provided to facilitate other sensing applications such as blood oxymetry, blood glucose, blood or fluid flow, biochemical or hormonal balance, blood chemistry, positional data, dynamic displacement data, ocular pressure, respiration, electro physiology, tissue stress, venous return and body acoustics.

In yet another aspect of the invention, sensors are attached to an endovascular graft using one continuous suture. Starting at one location on the sensor, a running stitch around the sensor is used to attach the sensor to the graft fabric, thereby minimizing the number of knots necessary for attachment, in this case a single knot. It is contemplated that the running stitch may start at any location on the sensor depending on the location of the sensor on the endovascular graft. Minimizing the number of knots is advantageous because knots are potential graft wear points and add bulk. Additionally, a single knot attachment design may allow the sensor to be placed close to the graft crotch due to the lack of a knot at the end closest the crotch.

In an additional aspect of the invention, the sensors may be covered in a coating that either inhibits tissue growth or promotes a known or controlled amount and/or type of tissue growth. Because tissue growth may interfere with the ability of a sensor to perform its measurement function, inhibiting tissue growth or  
5 restricting tissue growth to a known type and/or amount may increase the reliability of measurements obtained.

In addition to being attached directly to a graft component, an integrated sensor/transmitter, a sensor, a satellite sensor or a monument device incorporating one or more of the previously described identifying, observing, transmitting or  
10 measuring functions can be attached to a graft component via a bioreabsorbable suture or tether. Such devices are also contemplated to be attached to a graft component via a hard wire or other tether that functions to place the device in a position separate from the graft and in desired circumstances, maintain a space between the graft component and the identifying, observing, transmitting or  
15 measuring device.

The invention is applicable to all applications of endovascular grafts to treat aneurysmal segments of blood vessels. Furthermore, the invention and methods disclosed herein may be applied any time it is desired to measure intra-luminal parameters in a non-invasive manner. It is contemplated that the invention may be  
20 used with all shapes of endovascular grafts known within the art.

Other features and advantages of the present invention will become apparent from the following detailed description taken in conjunction with the accompanying drawings, which illustrate, by way of example, the principles of the invention.

#### BRIEF DESCRIPTION OF THE DRAWINGS

25 FIG. 1 is a partial cross-sectional view of one embodiment of the invention showing a partially assembled bifurcated endovascular graft implanted across an aneurysm sac;

FIG. 2 is a perspective view of another embodiment of the present invention showing a bifurcated graft with an integrated sensor/transmitter device and  
30 "satellite" sensors;

FIG. 3 is a perspective view of a typical integrated sensor/transmitter device of the present invention;

FIG. 4 is a partial cross-sectional view of an alternate embodiment of the invention shown in FIG. 2 showing a bifurcated graft implanted across an aneurysm sac into which an integrated sensor/transmitter device and "satellite" sensors have  
5 been attached;

FIG. 5 is a schematic view of another embodiment of the present invention showing an endovascular graft with monuments attached thereto implanted in a patient's body and an external source/receiver;

FIG. 6 is an enlarged view of a portion of graft fabric showing a sensor of the present invention attached using a single suture and running stitch;  
10

FIG. 7 is a partial cross-sectional view, depicting an identifying, observing or measuring device attached to a graft component by a bio-reabsorbable or hard wire tether or suture; and

FIG. 8 is a partial cross-sectional view, depicting the tether of FIG. 7 partially being reabsorbed.  
15

#### DETAILED DESCRIPTION OF THE PREFERRED EMBODIMENTS

As shown in the exemplary drawings and for purposes of illustration, the invention is embodied in a prosthetic endovascular graft having the ability to  
20 measure pertinent parameters inside the lumen into which it is implanted and transmit the measurements to a receiver located external to the patient.

Referring to FIG. 1, an embodiment of the invention is shown in which a modular bifurcated endovascular graft 10 of the type known within the art is implanted in a body vessel 40 across an aneurysm sac 42 in the area of the contra-  
25 lateral 44 and ipsi-lateral 46 iliac arteries using methods known within the art (only the contra-lateral limb is shown). The bifurcated endovascular graft 10 may be assembled in-vivo from a tubular trunk component 20 and two limb components 30. The trunk component 20 has a superior end 22 adapted to be secured above the aneurysm and an inferior end 24 adapted to accept the limb components 30. The  
30 limb component 30 has a transmitter 12, power source 14, and sensors 16 attached

external the graft material. The transmitter 12, power source 14 and sensors 16 can be integrated into one device as described below. The limb component 30 has a superior end 32 adapted to mate with the trunk component 20 inferior end 24 and an inferior end 34 adapted to be secured to the ipsi-lateral 44 iliac artery.

5           The sensors 16 measure pertinent parameters outside the endovascular graft 10 and the power source 14 provides power for the transmitter 12 which transmits the measurements to a receiver (not shown) located outside the patient's body. The transmitter 12, power source 14 and receiver (not shown) may be of any type known in the art of surgical implants or other systems utilizing miniaturized power  
10 sources and transmitters. The power source 14 and transmitter 12, for example, may be of the type used in pacemaker technology or passive power sources such as ultrasonic chargeable capacitors.

          One or more sensors 16 are located near the superior end 32 of the limb component 30 but inferior the attachment/sealing area 26 between the trunk  
15 component 20 and limb component 30 such that the seal between the trunk component 20 and limb component 30 is not jeopardized. Note that the attachment/sealing area 26 is such that one or more of the sensors 16 on the limb component 30 is adjacent the aneurysm sac 42, thereby facilitating measurement of pertinent parameters within the aneurysm sac 42 without encumbering the trunk  
20 component 20 with sensors 16. Note also that the transmitter 12 and power source 14 are attached to the limb component 30 such that they are also adjacent the aneurysm sac 42. Minimizing the bulk of the trunk component facilitates a smaller delivery profile for the endovascular graft 10.

          The sensors 16 may measure pressure, with the measurements used as an aid  
25 in endovascular graft 10 placement or to identify anomalies that occur after endovascular graft 10 implantation but before aneurysm rupture occurs. The sensors 16 may detect changes in pressure resulting from blood leakage between the endovascular graft 10 and the vessel wall 40, an endoleak resulting from an inadequate seal between them. Furthermore, the sensors 16 may detect changes in  
30 pressure resulting from leakage from an endoleak between the trunk 20 and vessel wall 40. Because sensors 16 are located in the area of the aneurysm sac 42, there

may be multiple sensors 16 disbursed over the graft material outer wall since local thrombus or calcification may shield one or more of the sensors 16 from blood flow and render their measurements erroneous. Moreover, the sensors 16 may allow pressure differences throughout the “excluded” aneurysm sac 42 to be mapped. It is contemplated that pressure measurements in the aneurysm sac may be obtained to an accuracy range of +/- 1 to 30 mm Hg and preferably of +/- 10 mm Hg.

Alternatively, the sensors 16 may measure temperature. Differences in temperature may identify “hot spots” associated with infection, inflammation, thrombus formation or other anomalies that indicate an increased risk for aneurysm rupture. Methods known in the art of pathology and physiology may be used to relate temperature to changes in the vessel walls within which the endovascular graft is implanted.

Alternatively, the sensors 16 may detect blood flow by measuring oxygen or other constituents, such as enzymes, proteins and nutrients, which are altered by the presence of blood flow. Such sensors may allow detection of minute blood flow, often missed by conventional imaging modalities, and, therefore, allow endoleaks to be detected earlier. One method is to obtain a baseline of the constituents upon implantation of the endovascular graft. Thereafter, changes in the amount of the measured constituents may be used to identify anomalies.

Alternatively, the sensors 16 may measure electrical potential or magnetic field strength. Changes in electrical potential may identify areas of the patient’s vasculature that are at risk for thrombus formation. Induced magnetic fields indicate motion at a charged portion of the aneurysm such as would occur from pulsatile pressure.

Sensors also may be provided to facilitate other sensing applications such as blood oxymetry, blood glucose, blood or fluid flow, biochemical or hormonal balance, blood chemistry, positional data, dynamic displacement data, ocular pressure, respiration, electro physiology, tissue stress, venous return and body acoustics.

Although shown external the limb component 30 in FIG. 1, it is contemplated that the transmitter 12, power source 14 and sensors 16 may be

located internal the graft material of the limb component 30. It is further contemplated that the number of transmitters 12, power sources 14 and sensors 16 shown in FIG. 1 may be varied to meet the requirements of the individual patient. It is further contemplated that sensors 16 which measure different pertinent parameters may be used together. Moreover, the invention shown in FIG. 1 may be utilized in any type of endovascular graft implant known in the art.

Referring to FIG. 2, another embodiment of the invention is shown in which an integrated sensor/transmitter 50 is attached to the endovascular graft 110 and "satellite" sensors 52 are attached at various locations on the endovascular graft 110. The integrated sensor/transmitter 50 is capable of measuring a pertinent parameter as well as transmitting measurements to a receiver (not shown) outside that patient's body. The "satellite" sensors 52 only measure pertinent parameters and their measurements are transmitted by the integrated sensor/transmitter, to which they are connected by leads 54. The "satellite" sensors 52 may provide a complete profile of pertinent parameters over the surface of the endovascular graft 110 and, therefore, facilitate better identification of anomalies.

Because the "satellite" sensors 52 are smaller than the integrated sensor/transmitter 50, the overall bulk of the endovascular graft 110 is smaller than if multiple integrated sensor/transmitter devices 50 were utilized. Furthermore, the smaller "satellite" sensors 52 may be placed such that measurements may be obtained from multiple locations, such as near the superior attachment area or within the aneurysm sac 42. Moreover, the smaller "satellite" sensors 52 facilitate measurements from places on the endovascular graft 110 where local graft bulk is a constraint of the design, such as the contra limb, or near the superior attachment system that holds the graft in the patient's aorta.

A separate power source 114 may be provided. The power source can be integrated into the sensor/transmitter as described previously and further below. The leads 54 which connect the integrated sensor/transmitter 50 to the "satellite" sensors 52 may be woven into the graft fabric or attached external to the endovascular graft 110.

It is contemplated that the location and number of integrated sensor/transmitter devices 50, power sources 114 and "satellite" sensors 52 shown in FIG. 2 may be varied to meet the requirements of the individual patient. In the embodiment shown, the integrated sensor/transmitter device 50 is located at the crotch, thereby allowing it to be near the center of the aneurysm sac 42 (see FIG. 2) while still being located furthest away from the aneurysm wall during shrinkage. It is further contemplated that the invention shown in FIG. 2 may be utilized in any type of endovascular graft implant known in the art.

Moreover, the integrated sensor/transmitter 50 and "satellite" sensors 52 may be of any type known in the art used to measure pressure, temperature, oxygen and other blood constituents, electrical potential or any other pertinent parameter indicative of endovascular graft or lumen health. One such integrated sensor/transmitter 50 to measure pressure is disclosed in U.S. Pat. Application Publication No. 2002/0045921 (Wolinsky et al.), the contents of which are hereby incorporated by reference. Again, other sensing applications may be supported such as blood oxymetry, blood glucose, blood or fluid flow, biochemical or hormonal balance, blood chemistry, positional data, dynamic displacement data, ocular pressure, respiration, electro physiology, tissue stress, venous return and body acoustics.

FIG. 3 shows a typical integrated sensor/transmitter 50 for use with the present invention. The integrated sensor/transmitter 50 includes a control chip 55 with a transmitter/receiver, energy exchanger 56, capacitor 57 and sensor 58. An external receiver (not shown) may contain a transducer, computer, LCD display and measurement display devices, such as barometers if the sensor 58 measures pressure. In operation, the transducer in the external receiver charges the capacitor 57 using ultrasonic energy and activates the sensor 58 to measure a pertinent parameter and ultrasonically transmit the measured parameter. The external receiver receives the transmitted pertinent parameter, assesses the measurement and displays the measurement, for example, as a pressure pulse curve.

Although FIG. 2 shows an integrated sensor/transmitter 50 and "satellite" sensors 52 connected by leads 54 and attached to the endovascular graft 110,

alternate embodiments of the invention may utilize an integrated sensor/transmitter 50 as the sole implant. Furthermore, the "satellite" sensors 52 may be attached to the vessel 40 with the integrated sensor/transmitter 50 either attached to the vessel 40 or attached to the endovascular graft 110. FIG. 4 shows an endovascular graft 110 implanted across an aneurysm sac 42 into which an integrated sensor/transmitter 50 connected to "satellite" sensors 52 by leads 54 have been attached. It is contemplated that pressure measurements in the aneurysm sac 42 may be obtained to an accuracy range of +/- 1 to 30 mm Hg and preferably +/- 10 mm Hg utilizing either an integrated sensor/transmitter 50 alone or in conjunction with one or more "satellite" sensors 52 or integrated sensor/transmitters 50.

In an alternate embodiment of the invention illustrated in FIGS. 2 and 4, micro devices having the capability to sense their location relative to each other are either attached to the endovascular graft 110 or attached to the vessel 40. The micro devices may be excited by an external energy source, sense their relative location and transmit the data to a receiver located outside the patient's body. The data may then be interpreted to determine if displacement of the endovascular graft 110 or changes in the geometry of the vessel 40 has occurred. Such changes may provide early detection of endovascular graft 110 displacement or aneurysm 42 re-dilation due to an endoleak. Additional micro devices could be provided for better resolution. Detecting location of the micro devices rather than measuring a pertinent parameter minimizes reliability problems due to encapsulation or thrombus isolation. It is contemplated that the micro devices may be an ultrasonic crystal attached or integral to a MEM chip having the ability to read, interpret and transmit data. The micro devices also may be ultrasonic or other energy reflectors utilized in conjunction with an energy source. Using ultrasound to show or image reflector location would be much easier than creating an ultrasound image of the tissue.

In a further embodiment of the invention illustrated in FIGS. 2 and 4, devices or monuments which perform no sensing function may be attached to the implanted endovascular graft 110 or directly attached to the aneurysm sac 42. The location of the monuments may be tracked with a monitoring device to detect

changes in the position of the endovascular graft 110 within the vessel 40 or changes in the geometry of the tissue outside the endovascular graft 110. It is contemplated that the monitoring device may be located external the patient's body or attached to an implanted endovascular graft. FIG. 5 illustrates an external monitoring device 54 being used to sense the location of an endovascular graft 310 having monuments 60 attached thereto which has been implanted in a patient's body. It is contemplated that the monuments may be electrically passive devices or magnetic sensors. The use of RF or magnets to sense the position of monuments is contemplated.

10 In one example, the position of magnetic sensors attached to the aneurysm sac 42 are measured using an external magnet of known magnetic field strength and shape. By moving the external magnet to multiple positions and orientations outside the body and polling the magnetic sensors with ultrasound, a baseline of magnetic sensor positions is established. Subsequent polling of the magnetic sensor positions allows changes in aneurysm sac 42 geometry to be detected.

15 In yet another embodiment of the invention shown in FIG. 6, sensors 16 or integrated sensor/transmitters 52 are attached to the endovascular graft 110 fabric using one continuous suture 70 with a running stitch, from a starting point 72 on sensor 16, which continues around the sensor 16 and back to an end point 74 (the dashed lines in FIG. 6 indicate where the suture 70 is on the inner diameter of the endovascular graft 110 fabric). Suture loops 71 are provided on the sensor 16 to facilitate attachment. A single knot 75 may be used to join the ends of the suture 70. It is contemplated that the running stitch may start and end at either end of the sensor and utilize more or less stitches depending on the location of the sensor 16 on the endovascular graft 110 and the attachment requirements. Minimizing the number of knots not only reduces bulk but also reduces potential graft wear points and may allow the sensor to be placed close to the graft crotch due to the lack of a knot at the distal end. It is further contemplated that the continuous suture 70 attachment method may be utilized with sensors 16 having suture holes or any other attachment mechanism.

In yet another embodiment of the invention, the sensors 16 may be covered in a coating, such as Teflon or heparin, to inhibit tissue growth or covered in a coating, such as Thrombin, to promote a known or controlled amount of tissue growth. Inhibiting or controlling tissue growth, which may interfere with performance, increases the reliability of the measurements made by the sensors 16.

With reference to FIGS. 7 and 8, there is shown alternative structure for attaching one or more of the previously described sensor/transmitter devices, sensors, satellite sensors, monuments or other devices 202 to a graft component 204. Although shown attached to a limb component 206 via a tether or suture 208, the identifying, observing, transmitting or measuring devices 202 also can be attached by way of a tether 208 to a main body component 210 or other component. In fact, in certain circumstances, the particular device 202 can be implanted in a vessel wall 220. Moreover, multiple devices 202 can be attached to a medical device in any desired pattern.

In one embodiment, the tether or suture 208 can embody a hard wire designed to maintain a distance between the identifying, observing, transmitting or measuring device 202 and the graft component 206, 210 itself. In this way, the device 202 can be maintained in an aneurysmal sac 212, for example, allowing the graft 206, 210 to repair vasculature without interference from the device 202. The hard wire tether 208 can be configured to resist any forces that may urge the device 202 against the graft 206, 210, thereby minimizing possible wear on the graft 206, 210 from the device 202.

In another embodiment, a bio-reabsorbable suture or tether 208 can be employed to attach the identifying, observing, transmitting or measuring device 202 to a graft 206, 210 or other component. After deployment of the graft 206, 210 within vasculature, the graft 206, 210 becomes covered in clot and as the clot organizes, the bio-reabsorbable tether 208 breaks down. After the tether breaks down, the identifying, observing, transmitting or measuring device 202 is left in an aneurysmal sac 212 or in a position separate from the graft. The device 202 is therefore held in place by tissue that is generated as a result of the interventional

procedure. Again, the device 202 is held separate from the graft 206, 210 thereby minimizing wear to the graft.

As suggested, the device 202 can embody any of the previously described devices such as a sensor/transmitter, a sensor or satellite sensor, a monument or a power supply. The device 202 can therefore work independently or in cooperation with any of the disclosed identifying, monitoring, sensing or transmitting devices.

While several particular forms of the invention have been illustrated and described, it will be apparent that various modifications can be made without departing from the spirit and scope of the invention. For example, the structures and sensors described can be used with any medical device or in any acceptable area of a patient's body. Accordingly, it is not intended that the invention be limited, except as by the appended claims.

WHAT IS CLAIMED:

1. A prosthesis for repairing vasculature, comprising:  
a first prosthesis component;  
a tether; and  
5 a device having a measuring or transmitting capabilities, the device attached to the first prosthesis component by the tether.
2. The prosthesis of claim 1, wherein the tether is configured to maintain a distance between the first prosthesis component and the device after the device is placed within vasculature.
- 10 3. The prosthesis of claim 1, wherein the tether is a hard wire tether.
4. The prosthesis of claim 1, wherein the tether is made of suture.
5. The prosthesis of claim 1, wherein the tether is bio-reabsorbable.
6. The prosthesis of claim 3, wherein the tether breaks down after clots form about the device to thereby hold the device in place separate from the first  
15 prosthesis component.
7. The prosthesis of claim 1, further comprising a second prosthesis component.
8. The prosthesis of claim 7, wherein the second prosthesis component is configured to mate with the first prosthesis component after the first prosthesis  
20 component is placed within vasculature.
9. The prosthesis of claim 8, wherein the first prosthesis component is configured to mate with the second prosthesis component after the second prosthesis component is placed within vasculature.
10. The prosthesis of claim 1, wherein the prosthesis is a modular graft  
25 assembly and the first prosthesis component is one of a plurality of graft components.
11. The prosthesis of claim 10, wherein only the first graft prosthesis component has the device attached thereto.
12. The prosthesis of claim 10, further comprising an additional device  
30 attached to more than one component of the plurality of graft components.

13. The prosthesis of claim 1, wherein the prosthesis is configured to treat an aneurysm and the tether maintains the device within an aneurysm sac.

14. The prosthesis of claim 1, wherein the device is a sensor/transmitter assembly.

5 15. The prosthesis of claim 1, wherein the device is a sensor.

16. The prosthesis of claim 1, wherein the device is a satellite sensor.

17. The prosthesis of claim 1, wherein the device is a monument.

18. The prosthesis of claim 1, wherein the device is a power supply.

10 19. The prosthesis of claim 1, wherein the device measures or cooperates to measure or identify blood constituents.

20. The prosthesis of claim 1, wherein the device measures or cooperates to measure or identify pressure.

21. The prosthesis of claim 1, wherein the device measures or cooperates to measure temperature.

15 22. The prosthesis of claim 1, wherein the device measures or cooperates to measure oxygen.

23. The prosthesis of claim 1, wherein the first prosthesis component is bifurcated and includes a first limb and a second limb, the device is attached to one of the first and second limbs.



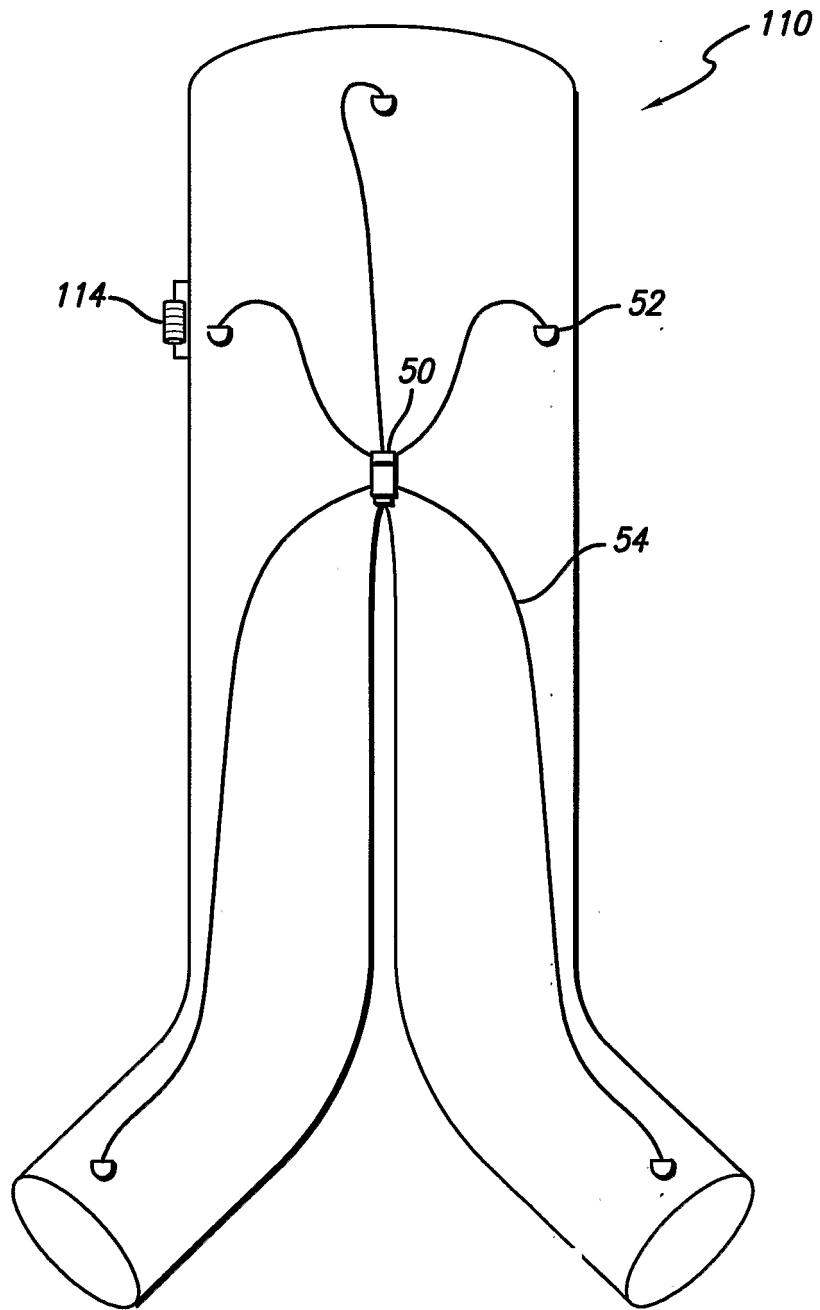

FIG. 2

FIG. 3

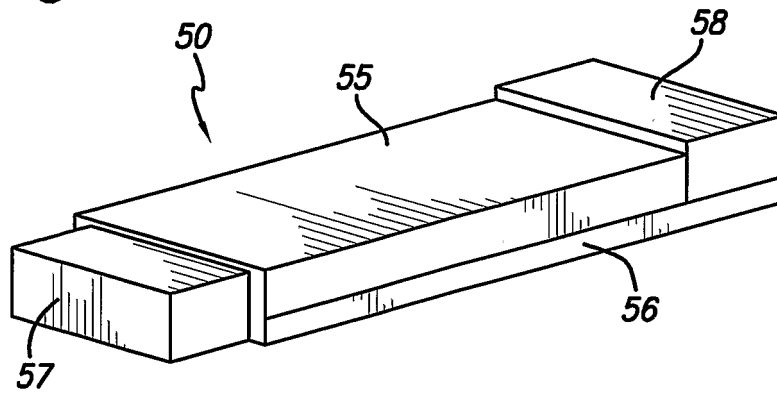
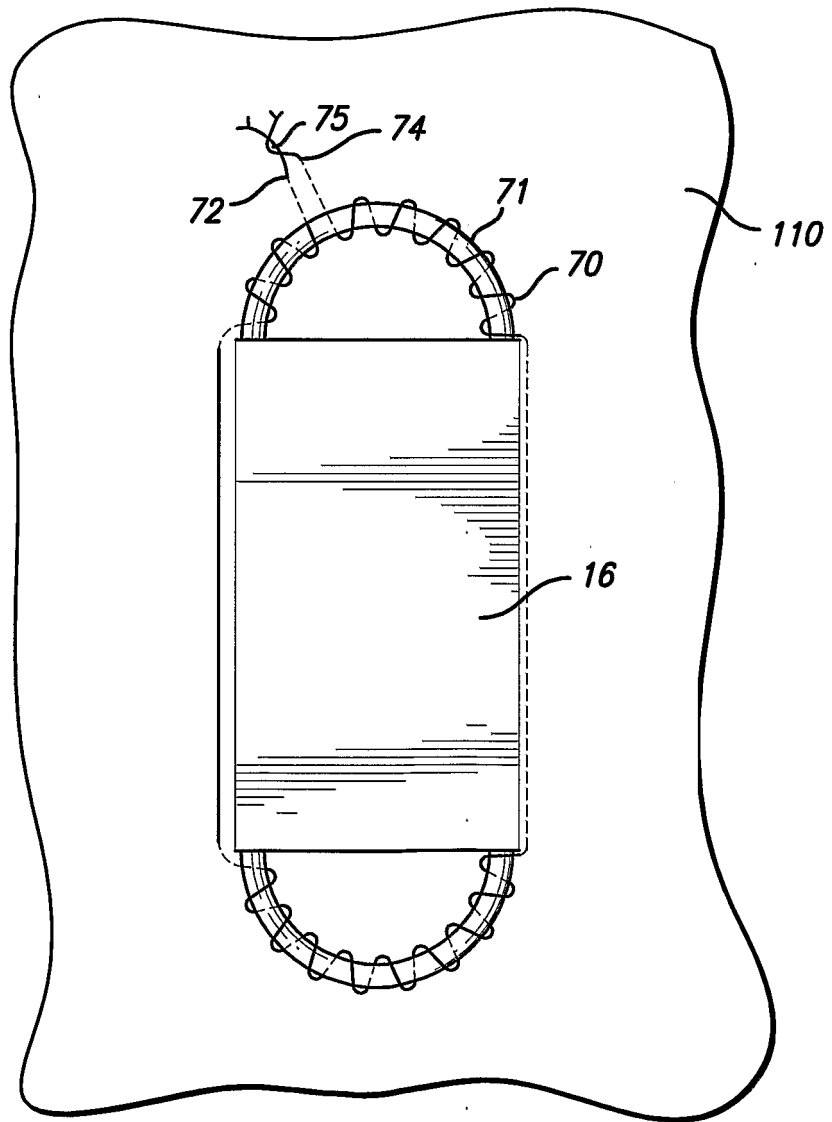

FIG. 6



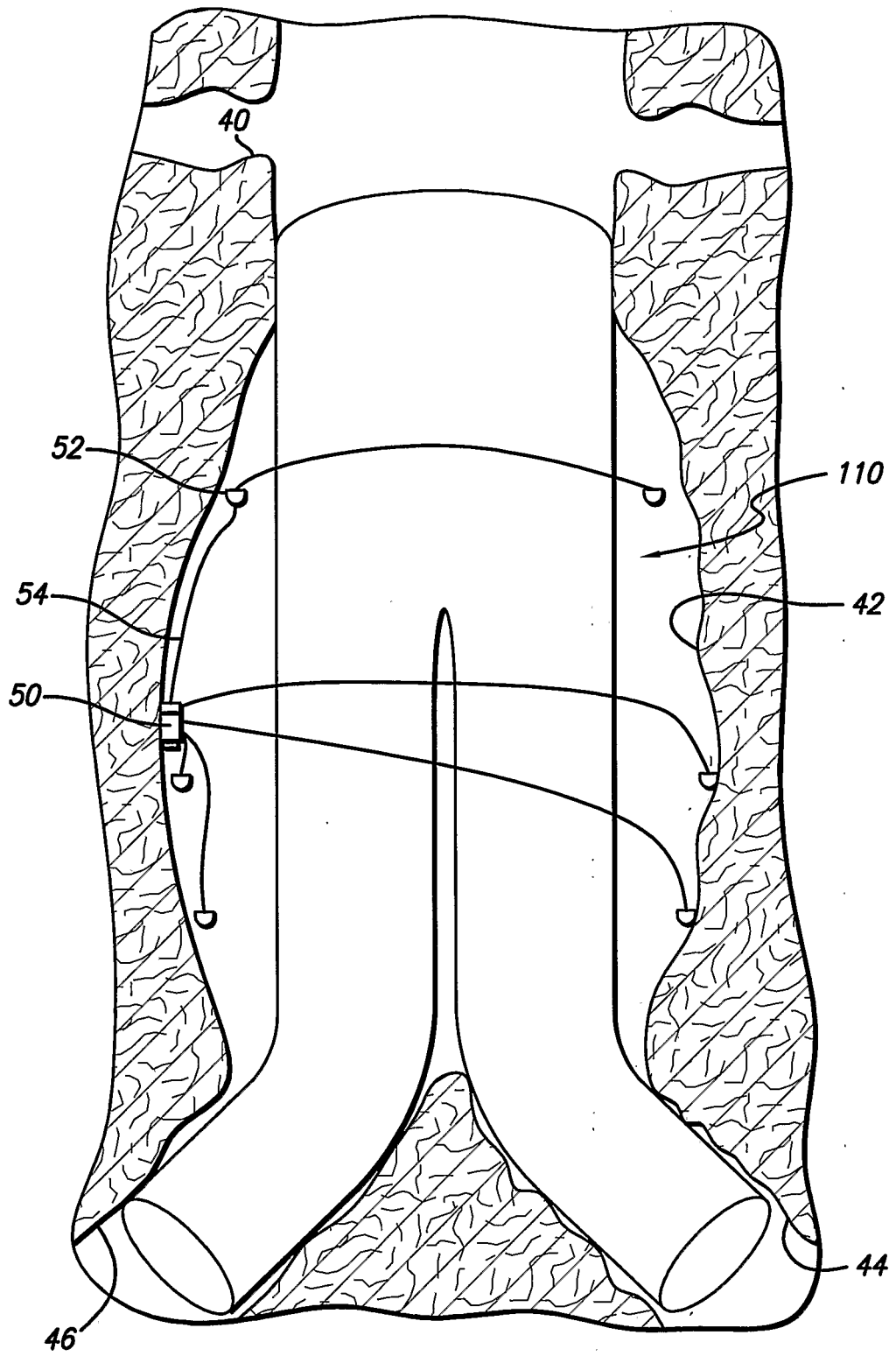

FIG. 4

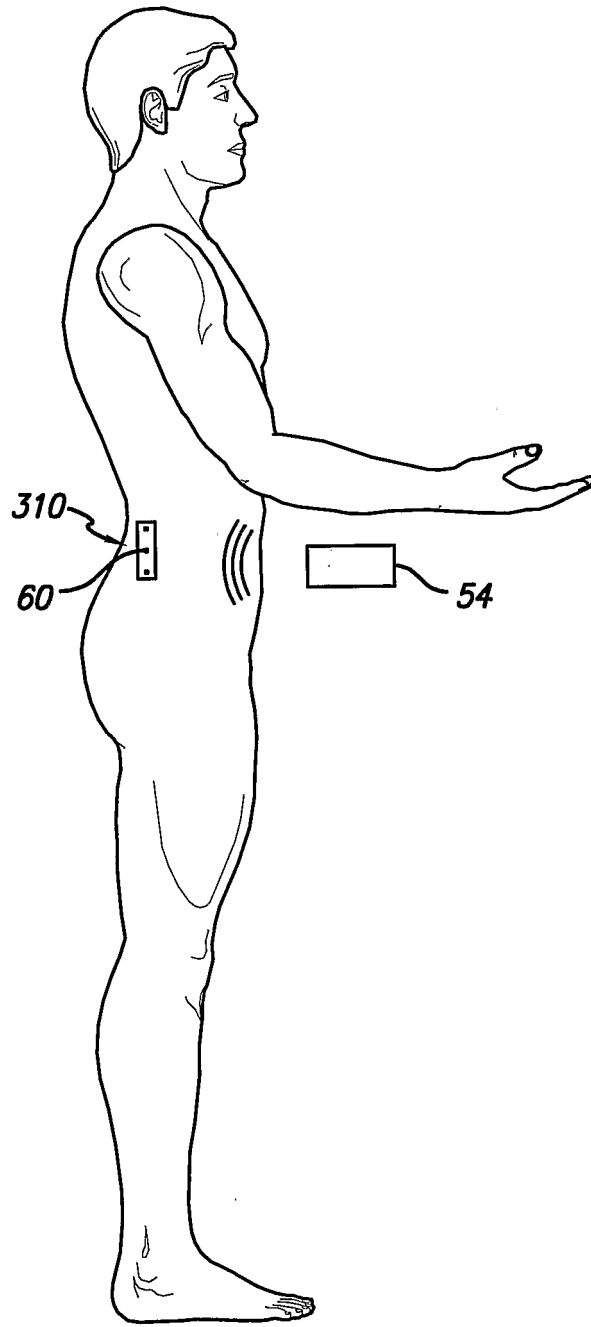

FIG. 5

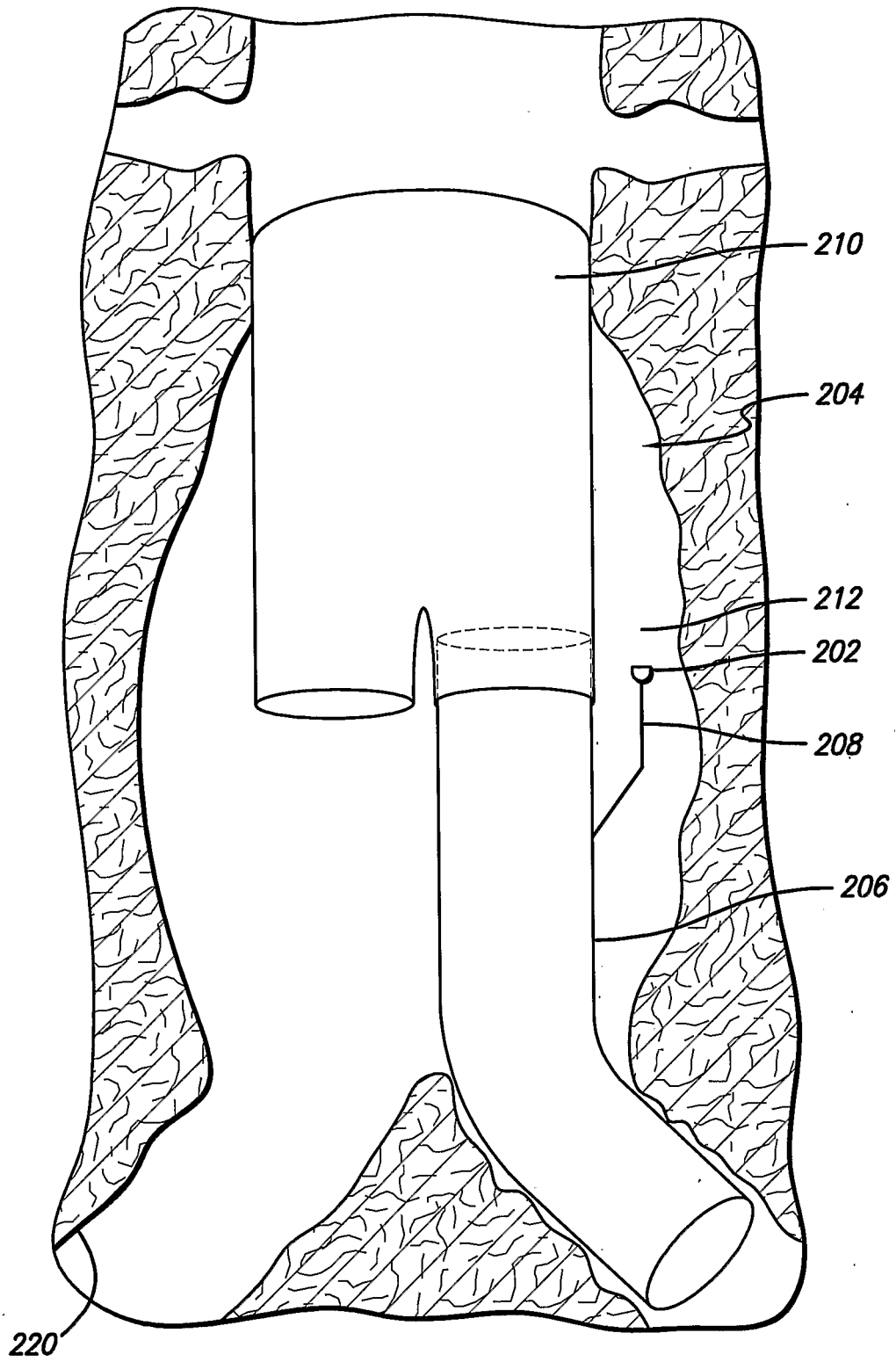

FIG. 7

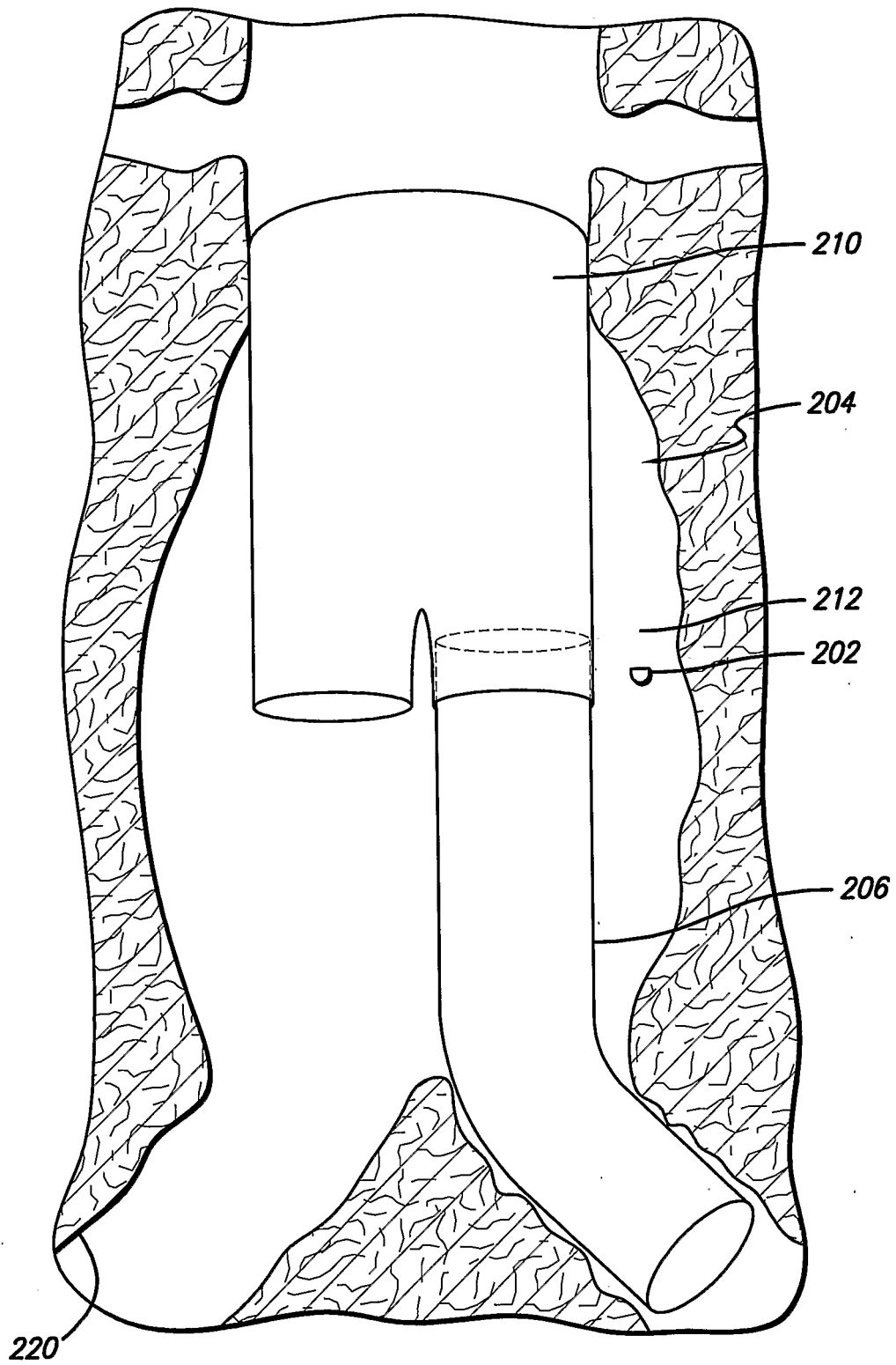

FIG. 8

专利名称(译)	带可分离传感器的血管内移植物		
公开(公告)号	<a href="#">EP1626678A2</a>	公开(公告)日	2006-02-22
申请号	EP2004753343	申请日	2004-05-26
[标]申请(专利权)人(译)	血管内TECH		
申请(专利权)人(译)	血管内TECHNOLOGIES , INC.		
当前申请(专利权)人(译)	血管内TECHNOLOGIES , INC.		
[标]发明人	BROWN PETER S KOVAC TIM WEI MICHAEL ECKERT ROBIN W		
发明人	BROWN, PETER, S. KOVAC, TIM WEI, MICHAEL ECKERT, ROBIN, W.		
IPC分类号	A61F2/06 A61F2/02 A61B5/00 A61B5/0215 A61B5/026 A61B5/05 A61F		
CPC分类号	A61B5/0031 A61B5/01 A61B5/02014 A61B5/0215 A61B5/026 A61B5/05 A61B5/145 A61B5/14532 A61F2/07 A61F2002/065 A61F2002/067 A61F2250/0002		
优先权	10/445723 2003-05-27 US		
其他公开文献	EP1626678B1 EP1626678A4		
外部链接	<a href="#">Espacenet</a>		

#### 摘要(译)

一种血管内移植物，其具有附接到其上的传感装置，以便于测量移植物植入其中的脉管系统内的相关参数。电源和发射器可以连接到移植物体上，以便于将测量结果传输到患者体外的接收装置。传感装置可以是具有测量和传输能力的电无源或集成装置。传感装置可以附接到移植物材料上的特定位置或附接到腔，从而从脉管系统内的关键点提供相关参数，或者可以分散在移植物材料的表面上或腔内，以提供轮廓。相关参数。传感装置可以使用一个缝合线使用一个缝合线连接到移植物材料上以使移植物体积最小化并且可以涂覆有抑制或控制组织生长的材料。可以使用生物可再吸收或硬线系绳或缝合线将装置连接到一个或多个移植物体组件上。