

(19) World Intellectual Property Organization
International Bureau



(43) International Publication Date
27 May 2004 (27.05.2004)

PCT

(10) International Publication Number
WO 2004/044562 A1

- (51) International Patent Classification⁷: **G01N 21/47**, 21/49, A61B 5/00, G02B 26/10, G01N 33/483, A61K 49/00
- (72) Inventors; and
- (75) Inventors/Applicants (*for US only*): **LONG, William, F.** [CA/CA]; 570 Charest Blvd. East, Suite 304, Québec, Québec G1K 9G3 (CA). **BERUBE-LAUZIERE, Yves** [CA/CA]; 4400 rue Barrette, Sherbrooke, Québec J1L 1T8 (CA). **HALL, David, J.** [GB/CA]; 3445 Drummond, Suite 1005, Montreal, Québec H3G 1X9 (CA). **MCINTOSH, Laura** [CA/CA]; 2950 Sommerset, Saint-Laurent, Québec H4K 1R5 (CA).
- (21) International Application Number: PCT/CA2003/001705
- (22) International Filing Date: 10 November 2003 (10.11.2003)
- (25) Filing Language: English
- (74) Agent: **OGILVY RENAULT**; Suite 1600, 1981 McGill College Avenue, Montreal, Québec H3A 2Y3 (CA).
- (26) Publication Language: English
- (81) Designated States (*national*): AE, AG, AL, AM, AT, AU, AZ, BA, BB, BG, BR, BW, BY, BZ, CA, CH, CN, CO, CR, CU, CZ, DE, DK, DM, DZ, EC, EE, EG, ES, FI, GB, GD, GE, GH, GM, HR, HU, ID, IL, IN, IS, JP, KE, KG, KP, KR, KZ, LC, LK, LR, LS, LT, LU, LV, MA, MD, MG, MK, MN, MW, MX, MZ, NI, NO, NZ, OM, PG, PH, PL, PT, RO, RU, SC, SD, SE, SG, SK, SL, SY, TJ, TM, TN, TR, TT, TZ, UA, UG, US, UZ, VC, VN, YU, ZA, ZM, ZW.
- (30) Priority Data:

PCT/IB02/04698	11 November 2002 (11.11.2002)	IB	
	10/317,856	12 December 2002 (12.12.2002)	US
	60/505,352	22 September 2003 (22.09.2003)	US
- (71) Applicant (*for all designated States except US*): **ART ADVANCED RESEARCH TECHNOLOGIES INC.** [CA/CA]; 2300 Alfred-Nobel Blvd., Saint-Laurent, Québec H4S 2S4 (CA).
- (84) Designated States (*regional*): ARIPO patent (BW, GH, GM, KE, LS, MW, MZ, SD, SL, SZ, TZ, UG, ZM, ZW),

[Continued on next page]

(54) Title: METHOD AND APPARATUS FOR TIME RESOLVED OPTICAL IMAGING OF BIOLOGICAL TISSUES AS PART OF ANIMALS

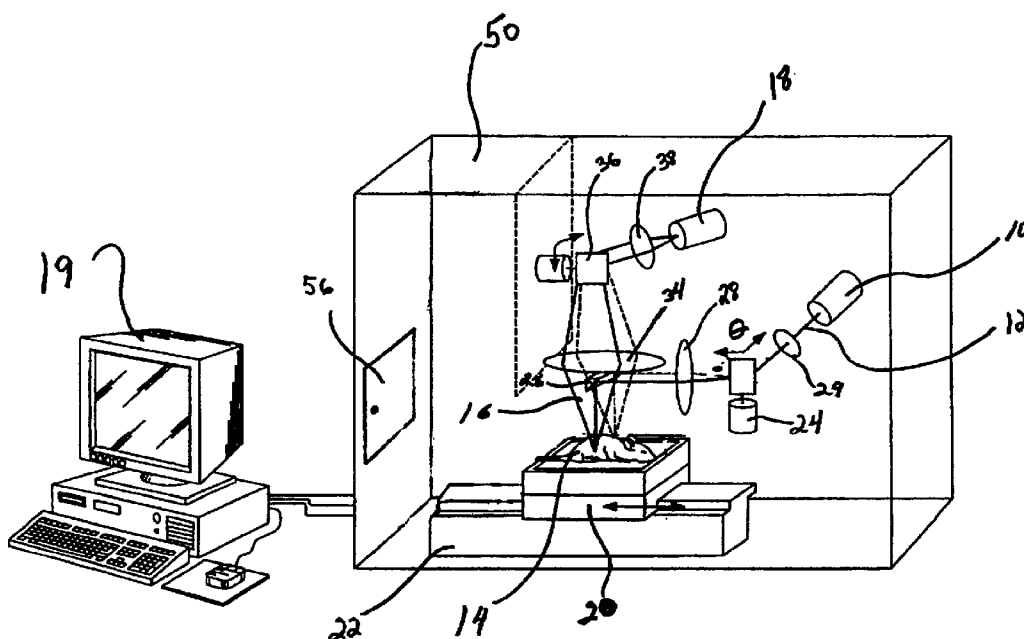

(57) Abstract: There is provided a method and system for collecting optical data for use in time resolved optical imaging wherein pulsed light is directionally propagated through free-space optics (24, 26, 28, 29) to impinge on a plurality of illumination at the surface of a biological tissue (14) such as that comprised in small animals. Light re-emitted from the tissue is collected and directionally propagated through free space optics (34, 36, 38) towards a detector (18) to produce time resolved optical signals useful for optical image reconstructions.

WO 2004/044562 A1



Eurasian patent (AM, AZ, BY, KG, KZ, MD, RU, TJ, TM),
European patent (AT, BE, BG, CH, CY, CZ, DE, DK, EE,
ES, FI, FR, GB, GR, HU, IE, IT, LU, MC, NL, PT, RO, SE,
SI, SK, TR), OAPI patent (BF, BJ, CF, CG, CI, CM, GA,
GN, GQ, GW, ML, MR, NE, SN, TD, TG).

For two-letter codes and other abbreviations, refer to the "Guidance Notes on Codes and Abbreviations" appearing at the beginning of each regular issue of the PCT Gazette.

Published:

— *with international search report*

METHOD AND APPARATUS FOR TIME RESOLVED OPTICAL IMAGING
OF BIOLOGICAL TISSUES AS PART OF ANIMALS

CROSS-REFERENCE TO RELATED APPLICATIONS

This application is a continuation of U.S. Patent Application
5 Serial No. 10/665,297 filed September 22, 2003 and entitled
"METHOD AND APPARATUS FOR TIME RESOLVED OPTICAL IMAGING OF
BIOLOGICAL TISSUE AS PART OF ANIMALS"; and claims priority
under 35 USC §119(e) from PCT Application Serial
No. PCT/IB02/04698 filed November 11, 2002 and entitled
10 "METHOD AND APPARATUS FOR TIME RESOLVED OPTICAL IMAGING OF
BIOLOGICAL TISSUE"; and further claims priority from U.S.
Patent Application Serial No. 10/665,297 filed September 22,
2003 and entitled "METHOD AND APPARATUS FOR TIME RESOLVED
OPTICAL IMAGING OF BIOLOGICAL TISSUES AS PART OF ANIMALS"; and
15 U.S. Patent Application Serial No. 60/505,352 filed
December 12, 2002 and entitled "METHOD AND APPARATUS FOR TIME
RESOLVED OPTICAL IMAGING OF BIOLOGICAL TISSUE".

This application is related to commonly assigned co-pending
U.S. Patent Application Serial No. 10/624,902 bearing agent
20 docket number 15186-41US, the specification of which is hereby
incorporated by reference.

TECHNICAL FIELD

The invention relates to the field of optical imaging of
turbid media such as biological tissues as part of animals.
25 More specifically, the invention relates to time resolved
optical data acquisition for use in optical imaging.

BACKGROUND OF THE INVENTION

Different types of imaging techniques such as positron
emission tomography (PET), magnetic resonance imaging (MRI)

and ultrasound imaging are available that can non-invasively gather information from within biological tissues as a basis for image reconstruction. More recently, another imaging technique, namely optical imaging has been the subject of
5 intense research and commercial development.

Optical imaging is based on the information that can be derived from the analysis of the signal resulting from the interaction of light with matter as it is propagated within an object. Optical imaging of turbid medium can be performed
10 using three different approaches namely continuous wave (CW), time domain (TD) and frequency domain (FD). CW is the simplest and least expensive of the three techniques but provides only limited information with regards to the spatial distribution of internal optical attenuation of the object being imaged. TD
15 and FD, by conveying information on the time required by photons to travel within the object (FD through the Fourier transform) are considered to be "time resolved" and can be used to calculate the spatial distribution of optical characteristics of the object, such as absorption and scatter
20 coefficients, via well known photon diffusion equations (for a review paper on this topic, see the article by Hawrysz and Sevick-Muraca, Neoplasia, vol.2 No 5, pp388-417, 2000)..

Optical imaging is particularly attractive in view of its non-invasiveness which permits the acquisition of in vivo
25 information without damaging biological tissues. Furthermore the technique may be useful to monitor drug distribution, detect the presence of abnormalities within organs, or map physiological activities within mammals.

However, widespread utilization of optical imaging systems has been impeded by some undesirable characteristics of existing systems. For example, optical imaging devices often require cumbersome arrangements of optical fibers that are used to transport the light to and from the object. Such systems have been described for example by Ntziachristos and Weissleder in patent application WO 02/41769 and by Hillman et al. Phys. Med. Biol, 46 (2001)1117-1130. The type of arrangement for the optical components described in these references requires a time consuming alignment of the region of interest with the optic fibers used to illuminate the object and detect the optical signal. This type of arrangement is particularly problematic when imaging is performed on living tissues of mammals.

Ease of data acquisition and in particular ease of the positioning the object relative to the optic components is especially important in applications requiring high throughput such as in clinical settings or in research that make use of small mammals such as mice. In this respect, commercially available optical imaging systems for imaging small mammals have been developed. For example, a bioluminescence imaging system developed by Xenogen Corp. (Biophotonics, vol.9, No.7 pp48-51, 2002) has been designed to collect light emanating from small mammals. However, this imaging device suffers from certain disadvantages. For example, it requires the presence of bioluminescent molecules which have a spatially restricted biodistribution profile therefore greatly reducing the flexibility in imaging desired region of interests (ROI). Furthermore, the technique is limited by the number of

luminescent molecules that are currently available. Moreover, the system does not allow time resolved data to be acquired.

In view of the above, it would be desirable to provide an optical imaging system for imaging turbid media such as biological tissues that allows time resolved optical data to be acquired with increased flexibility and efficiency.

SUMMARY OF THE INVENTION

According to one broad aspect of the invention there is provided a system and method for time resolved optical imaging of biological tissues as part of an animal. The design of the optical components of the present system allows a beam of light to be directionally propagated through air, that is to say through free-space optics, to impinge on desired points of illuminations in a region of interest (ROI) of the tissue. Light re-emitted from the tissue is collected at collection points and directionally propagated through air (i.e. through free-space optics) towards a detector. The fact that the light is propagated through air allows for a greater flexibility in scanning different ROI by eliminating the need for cumbersome fiber optics arrangements. Thus there is no need for directly contacting the animal with optical components thereby leaving sufficient space to manipulate or access the animal.

The optical design of the system permits illumination and light collection through air of nearby points in the ROI with minimal interference between the illumination beam, or the light reflected at the skin/air interface, and the collected light.

In one embodiment, there is provided a time resolved optical imaging method which comprises illuminating, at one or more wavelengths, a region of interest of an animal at a plurality of predetermined illumination points using a pulsed light beam. The beam is propagated through air and directed by using appropriate optical components to the illumination points. A plurality of predetermined collection points are collected by optic components having a configuration enabling selective collection of light from well defined surface areas in the ROI. The collected light is then directed to a detector to produce an optical signal that can be used to generate an optical image using reconstruction algorithms.

In a further aspect of the invention there is provided a system for collecting optical data for use in time resolved imaging comprising one or more light sources for providing a light beam at one or more wavelengths, illuminating optic components for directionally propagating the beam through air such that a region of interest of the biological tissue within an animal is illuminated at a plurality of illumination points thereby injecting light into the tissue, collecting optic components for collecting light re-emitted at a plurality of predetermined collection points in the region of interest and for directionally propagating through air the collected light and a time correlated detector for detecting the collected light.

The system of the invention may advantageously be configured to acquire data for topographic or tomographic imaging. Topographic imaging is achieved by maintaining constant the

distance between collection points and illumination points. Synchronized mirrors galvanometers are provided in the illumination and collection optics to achieve a constant distance between the illumination points and the detection
5 points. Topographic data acquisition configurations can be used to obtain 2 dimensional (2D) or 3 dimensional (3D) images.

Tomographic imaging requires that light re-emitted from the animal be sampled at several different collection
10 points/detection points configurations. The system of the present invention advantageously provides moveable mirrors in the illumination and collection optics that are independently controllable thereby providing means to achieve a plurality of illumination points/ collection points configurations.

15 In another aspect there is provided a method and system for optical imaging of biological tissue containing fluorescent molecules. The tissue can be illuminated at an excitation wavelength while light re-emitted can be collected and detected at an emission wavelength. The system also enables
20 detection of both the emission wavelength and the excitation wavelength.

BRIEF DESCRIPTION OF THE DRAWINGS

Further features and advantages of the present invention will become apparent from the following detailed description, taken
25 in combination with the appended drawings, in which:

FIG. 1 is a flow chart diagram of an embodiment of the method of the instant invention;

FIG. 2 is perspective view of an embodiment of the system of the invention;

FIG. 3 is as schematic representation of an embodiment of the system in which the source comprises a plurality of lasers;

5 FIG. 4 schematically illustrates a raster scan pattern of illumination in a region of interest at the surface of a mammal;

FIG. 5 a schematic representation of an embodiment of the system of the invention in which the optical components are
10 mounted on a gantry to be rotated around the mammal to acquire data for tomographic imaging; and

FIG. 6 is a schematic representation of an embodiment of the system of the invention in which the optical components are fixed and the mammal is rotated to acquire data for
15 tomographic imaging.

It will be noted that throughout the appended drawings, like features are identified by like reference numerals.

DESCRIPTION OF THE PREFERRED EMBODIMENT

The invention relates to the field of optical imaging of
20 turbid media such as biological tissues as parts of animals.
.While the following description of the preferred embodiment provides examples that relate to imaging of small mammals such as mice, it will be appreciated that the method can also be applied to larger animals and in particular to laboratory
25 animals such as dogs, pigs and primates..

With reference to FIG. 1 an embodiment of the method of the present invention for collecting optical data for use in time resolved optical imaging is generally described. At 2 pulsed light from a source of a selected intensity is directionally propagated in air (i.e. through free space optics) to illuminate a plurality of predetermined illumination points in a ROI of comprising biological tissue within an animal. The light emanating from a plurality of collection points after diffusion through the tissue is selectively collected through free space optics at 4 and directionally propagated through free space at 6 towards a detector. The collected light is finally measured at 8 using the detector to produce a time resolved optical signal. Light emanating from points other than that being sampled is optically excluded from detection.

The embodiments of the system used for collecting the optical data will now be described referring to small mammals as the object to be imaged but it will be appreciated that a wide variety of biological tissues may be amenable to optical imaging using the technique described herein. These can be but are not limited to breast tissue, brain, tumors and the like.

A general schematic representation of the system of the present invention used for imaging small mammals is shown in FIG. 2. The system comprises a light source 10 capable of generating a beam of light 12 at one or more wavelengths, illuminating optics for directionally propagating the beam of light through air, i.e. through free space optics, to desired illumination points on the surface of the mammal 14, collecting optics for collecting the light 16 re-emitted from

the mammal for directionally propagating the collected light to a detector 18, a moveable mammal supporting tray 20 mounted on a translational stage 22 and a computer 19 for controlling the source, the optics, the detector and the tray.

5 The illuminating optics comprises a moveable reflective mirror 24 which is preferably a mirror galvanometer. The beam is reflected by the mirror galvanometer at an angle θ and directed towards a thin angled mirror 26 which reflects the beam in a direction substantially perpendicular to the surface
10 of the mammal being scanned. It can be appreciated that the partial rotation of the mirror galvanometer will modify the angle θ and direct the beam to a different point on the thin angled mirror and, consequently, to a different illumination point on the surface of the mammal. Successive partial
15 rotations of the mirror galvanometer 24 thus produces a line scan substantially parallel to the thin angled mirror. Lens 28 is optionally provided and positioned between the mirror galvanometer and the thin angled mirror such that the mirror galvanometer is at the focal distance of the lens to provide
20 telecentric imaging. Filters such as neutral density filter 29 may also be positioned between the source and mirror galvanometer 24 to adjust the intensity of the light beam.

In an aspect of the invention, the light source is preferably a variable intensity laser emitting light at a specific
25 wavelength. To produce a multi-wavelengths illumination a collection of lasers 31, such as diode lasers, each emitting light at different wavelengths may be used (FIG. 3). Appropriate filters such as filters 33 and 35 may be

positioned between the source and the mammal and between the re-emitted light and the detector for the selection of wavelengths or to adjust the intensity of the light. A switching or dichroic mirror system may be used for either
5 sequential or simultaneous illumination of the mammal at different wavelengths. Alternatively, a unique multi-wavelengths source of light may also be used. In the latter case, ranges of wavelengths or specific wavelengths may be selected by using filters, gratings or the like, as is well
10 known by persons skilled in the art.

The preferred intensity of the source is determined by Maximum Permissible Exposure (MPE) limits for biological tissues as established by regulatory instances. Standards for safe exposure are outlined, for example, in American National
15 Standard for the safe use of lasers (ANSI Z 136.1-2000). For example, a laser emitting in the near infrared (NIR) should preferably be adjusted at a power of about 200 mW or less for non-invasive imaging of biological tissues such as that comprising humans and small mammals.

20 Tray 20 supports the mammal while it is being imaged. The mammal is preferably anesthetized for the duration of the data collection to reduce movements to a minimum. In alternative embodiment parts of or the whole animal could be mechanically restrained to reduce movements. Optionally the tray can be
25 heated to maintain the body temperature of the mammal. Furthermore the tray can be displaced longitudinally on a translational stage 22 to position the mammal such that a plurality of line scans parallel to each other can be

generated. This stepwise process is repeated a selected number of times to produce a raster scan of a region of interest (ROI). The raster scan can alternatively be achieved by longitudinally displacing the thin angled mirror 26. FIG. 3
5 illustrates an example of a raster scan pattern at the surface of a mammal. The user defined ROI 40 delimits the area to be scanned which comprises the predetermined illumination points 42. The arrangement of the optic components also permits other scanning patterns to be performed. It will be appreciated that
10 the ROI may consist of the whole animal.

Light re-emitted from the mammal is collected by the collecting optics which comprise collecting lens 34, reflective mirror 36 which is preferably a mirror galvanometer and lens 38. Collecting lens 34 is located above the ROI and
15 above the thin angled mirror. The angular position of the mirror 36 relative to the incoming light and the detector determines which collection point is being sampled since only part of the light (corresponding to a given collection point) impinging on the mirror is reflected at the proper angle to
20 reach the detector. Selective detection of the light from a given collection point may be further enhanced by optically coupling the mirror galvanometer with lenses and/or pinholes.

The overall arrangement of the optics, which permits propagation of the light through air, allows for easy
25 positioning and manipulation of the animal. Furthermore, since the system does not rely on optic fibers, a plurality of ROIs can be scanned without manipulating the animal simply by moving the tray so that a new ROI is brought in the focus of

the optics. The movements of the tray can be controlled externally using the computer.

Upon impinging on the surface of the mammal, part of the light penetrates the skin and part is reflected at the air/skin boundary. The photons that are propagated within the mammal are absorbed and scattered, thereby producing a large number of photon paths. In biological tissues absorption may arise as a result of the presence of natural (endogenous) or exogenous chromophores while scattering is triggered by the presence of macromolecular structures such as proteins, lipids and the like which create refractive index inhomogeneities. The fraction of the light that is not absorbed ultimately exits the mammal by diffusing through the skin barrier at various distances from the illumination point. It can be appreciated that photons that have traveled deeper in the tissue will take a longer time to exit at the surface of the mammal. This provides the basis for the time resolved detection of the optical signal from which useful information about the optical properties of a region of interest can be extracted to be incorporated into image reconstruction algorithms. In optically homogeneous media the distance between the illumination point and the point at which given photons exit is related to the effective depth of the average path of the photons. Thus the greater the distance between the points the greater the depth. While biological tissues are not optically homogeneous the distance between illumination points and the point of photon exit can also be considered to be related to the depth of the average path of photons.

In a preferred embodiment the time resolved method used in the system of the present invention is time domain (TD). In TD measurements the source is briefly pulsed and the optical signal is detected as a function of time to generate a temporal point spread function (TPSF). The source is preferably a laser source capable of generating pulses characterized by a width in the picoseconds range. Time domain detectors such as time gated intensified CCDs (ICCDs), time correlated single photon counting devices (TCSPC's), ultrafast semiconductor detectors (avalanche and PIN photodiodes), photomultipliers and streak cameras can be used. In a preferred embodiment a TCSPC device is used in the system of the present invention. TCSPC's are capable of measuring the time taken by a photon to reach the detector as it travels through the illuminating optic, the tissue and the collecting optic. Time measurement is provided by a "clock" circuitry electronically coupling the source and the detector. Such circuits are well known in the art. TCSPC's are very sensitive and advantageously allows the use of low power sources to minimize damage to the tissue being scanned.

In an embodiment of the invention, attenuation measurements similar to measurements obtained using continuous wave can be generated using the system and method of the present invention by integrating the TPSF.

Statistically, the efficiency of detection, that is to say the ratio of the number of photons produced by the source and directed at a particular illumination point and the number of photons detected from a given collection point, is a function,

inter alia, of the power of the light source and the distance from the illumination point at which the light is collected. The intensity of the source may be adjusted so that the flux of photons reaching the detector is optimized for the characteristics of the detector. In a preferred embodiment, in which TD imaging of small mammals is performed using a TCSPC detection system, it is generally required that the probability of detecting a photon for each illumination light pulse be approximately 1% in order to avoid distortions caused by electronics dead-time losses in the temporal profile being measured as is well known by a person skilled in the art. The illumination duration (which is provided by the number of light pulses) directed at a given point on the mammal may vary in order to provide a sufficient number of detected photons to produce an adequate signal and yet keep the duration as short as possible to reduce the acquisition time. In accordance with the example of small animal imaging and using a light source emitting pulses at a frequency of 80MHz, the power of the beam should be adjusted so that approximately 8×10^5 photons per second are detected. It will be appreciated that the selection of the appropriate frequency is based on, among other factors, the characteristics of the optical components, of the detector, of the tissue to be imaged and of the type of optical data that is desired.

The TPSF may also be generated by using a time gated intensified charged coupled device (ICCD). This type of detector can provide spatial resolution enabling simultaneous detection of optical signals emanating from different collection points. Furthermore when a source generating two or

more wavelengths is used, the light collected at any given collection points can be divided into constituent wavelengths to produce two or more beams which can be directed to different detection positions of the ICCD. However, since the
5 sensitivity of an ICCD is less than that of a TCSPC device, the intensity of the source should be adjusted accordingly while remaining below levels that could cause tissue damage.

In view of the low intensity levels of the source, especially in the case where TCSPC devices are used, and the high
10 sensitivity of the detectors, the system and the mammal are placed in an enclosure such as a box 50. The box is preferably light tight to prevent any stray light from interfering with the measurements. The interior of the box can be accessed through door 56.

15 In order to construct an image of a region of interest (ROI) within the mammal, optical signals are obtained from a plurality of illumination/detection points within the ROI. The configuration of the illumination/detection points may vary depending of the type of image to be reconstructed. As will be
20 explained below topographic and tomographic images can be generated with the system and method of the present invention and both require different illumination/detection configurations.

The position of the collection points relative to the
25 illumination points is determined prior to the start of the acquisition and is a function of the desired depth of imaging in the region of interest. For planes of imaging that are close to the surface of the skin, the collection points are

located near the illumination points since the deeper a photon travels, the lower is the probability of that photon being re-emitted near the illumination points, and conversely.

Thus in order to acquire topographic images collection points
5 are maintained at a fixed distance from illumination points so as to gather information from substantially the same depth across the ROI. The mirror galvanometers comprised in the illuminating and the collecting optic may be synchronized to achieve rapid scanning with a constant illumination/detection
10 points distance.

Tomographic data is obtained when the illumination and collection points are permuted so as to generate a plurality of illumination to collection points distances thereby obtaining information from different depths. By treating the
15 data in an appropriate manner, tomographic images can be generated. For tomographic optical data acquisition the two mirror galvanometers 24 and 26 are preferably controlled independently in order to obtain multi-perspective data. Thus while the mirror galvanometer in the illumination optic
20 directs the light at a desired illumination point, the mirror galvanometer in the collection optic may be programmed to sample light at a plurality of different collection points.

In one embodiment, the illumination and collection optics are mounted on a movable gantry system 52 which turns around the
25 animal (FIG. 5). In this particular embodiment, the tray preferably exhibits an "I" shape. This particular shape facilitates data acquisition as the illumination and collection optics is rotated around the region of interest

(for example: torso region) while allowing the animal to be comfortably supported. With this configuration, angular displacements of an amplitude substantially equals to 360 degrees are possible. In a further embodiment, the mammal may be rotated instead of the gantry. The mammal may be maintained on the tray by attaching its legs to the tray. Rotation around the cranio-caudal axis of the body by 360° is possible. This design configuration can reduce weight, volume and complexity compared to the moveable gantry system.

10 In yet another embodiment the mammal can be rotated along the cranio-caudal axis while sitting. The animal is positioned on the stage such that the region of interest is kept straight by softly supporting its head. These designs allow the animal to be scanned over almost 360°. It will be appreciated that the optics may be modified to adapt it to the different tomographic configurations. For example, mirror 54 in the "sitting" configuration provides a convenient way of directionally propagating the light.

The acquisition of optical data at a plurality of angles around the animal may result in appreciable variations in the distance between the surface of the ROI and the collection optics because of the irregular contour of the animal. Accordingly image reconstruction may be improved by the use of an auto-focus system and by obtaining a profile of the scanned regions. In this respect, the system may also comprise means to determine the volumetric profile of the animal. In one embodiment, the volumetric profile can be determined by scanning the animal with a laser beam directed substantially

perpendicularly to the animal. By simultaneously acquiring an image of the laser beam at the surface of the animal with a video camera placed at an angle to the laser path, the volumetric profile may be determined. The animal may be scanned by moving the tray. It will be appreciated that the volumetric profile thus obtained provides spatial information useful for image reconstruction and display.

While the imaging of biological tissue can rely on the natural optical properties of the endogenous molecules for providing optical contrast, exogenous molecules may be introduced in the tissue to provide additional contrast. In this respect, exogenous chromophores as well as fluorophores may be used. Furthermore the biodistribution of such contrast agents can be followed using the method and system of the present invention. In one advantageous embodiment the biodistribution can be followed over time thereby producing pharmacokinetics data.

The optics as well as the source can be arranged to illuminate and detect light at one or more wavelengths as is described supra. This property can be exploited to follow the pharmacokinetics of two or more fluorophores and/or chromophores. In particular, the source and associated optics can be arranged to illuminate at an excitation wavelength of a fluorophore while the detector and associated optics can be arranged to detect light at an emission wavelength of the fluorophore.

The embodiment(s) of the invention described above is(are) intended to be exemplary only. The scope of the invention is

therefore intended to be limited solely by the scope of the appended claims.

CLAIMS:

1. A method for collecting optical data for use in time resolved optical imaging of an animal, the method comprising:

- i) positioning said animal for data acquisition through free-space optics
- ii) directionally propagating through free-space optics a pulsed light beam of a selected intensity to illuminate at one or more wavelength a plurality of predetermined illumination points in a region of interest of the animal;
- iii) selectively collecting, through free-space optics, light emanating from a plurality of predetermined collection points;
- iv) directionally propagating through free-space optics the collected light towards a detector;
- v) measuring, at one or more wavelength, the collected light at the detector to produce a time resolved optical signal for one or more illumination points/collection points configuration; and

wherein light emanating from points other than the predetermined collection points is optically excluded from detection.

2. The method as claimed in claim 1, wherein the time resolved optical imaging is time domain (TD) imaging and wherein the time resolved optical signal is detected such as

to generate information related to a temporal point spread function (TPSF).

3. The method as claimed in claim 2, wherein the step of measuring comprises detecting the collected light using time correlated single photon counting approach.

4. The method as claimed in claim 3, wherein each illumination point is illuminated by a plurality of pulses.

5. The method as claimed in claim 4, wherein the step of illuminating comprises adjusting the intensity of the light beam such as to avoid distortions caused by electronics dead-time losses.

6. The method as claimed in claim 5, wherein the intensity is adjusted by varying the source intensity.

7. The method as claimed in claim 6, wherein the intensity is adjusted with filters.

8. The method as claimed in any one of claim 1-7, wherein the optical signal is detected at two or more wavelengths simultaneously.

9. The method as claimed in any one of claim 1-7 wherein the optical signal is detected at two or more wavelengths sequentially.

10. The method as claimed in any one of claim 1-9, wherein the illumination points are illuminated in a raster scan fashion.
11. The method as claimed in any one of claim 1-10, wherein the collection points are located at a fixed distance from the illumination points to provide optical signal for topographic imaging .
12. The method as claimed in claim 11, wherein the distance is about 3mm.
13. The method as claimed in any one of claim 1-10, wherein two or more collection points are collected for each illumination point to provide optical data for tomographic imaging.
14. The method as claimed in claim 13, wherein at least two of the 2 or more collection points are collected simultaneously.
15. The method as claimed in any one of claim 1-14, wherein detection is effected at a wavelength different from that of illumination.
16. The method as claimed in any one of claim 1-15, wherein the biological tissue comprises one or more fluorophores and wherein the detection wavelength corresponds to an emission wavelength of the one or more fluorophores and the

illumination wavelength corresponds to an excitation wavelength of the one or more fluorophores.

17. The method as claimed in claim 16, wherein both the excitation and emission wavelength are detected.

18. The method as claimed in any one of claim 2-17, wherein the TPSF is integrated to provide attenuation measurement.

19. The method as claimed in any one of claim 1-18, wherein optical data from a plurality of regions of interest are collected during a single session.

20. The method as claimed in claim 19, wherein the plurality of regions of interest comprises a whole body of an animal.

21. The method as claimed in any one of claim 1-20 wherein said animal is controllably heated.

22. A system for collecting optical data for use in time resolved optical imaging of an animal, the system comprising:

- i) one or more pulsed light source of selected intensity for providing a light beam at one or more wavelengths;
- ii) illuminating optic components for directionally propagating the beam through free space optics such that a region of interest of the biological tissue is illuminated at a plurality of illumination points thereby injecting light into the animal;

- iii) collecting optic components for collecting through free space optics light re-emitted at a plurality of predetermined collection points in the region of interest such that light emanating from points other than the predetermined collection points is optically excluded from detection, and for directionally propagating, through free space optics, the collected light; and
- iv) a time domain detector for detecting the collected light.

23. The system as claimed in claim 22, wherein the one or more light sources are variable intensity light sources.

24. The system as claimed in claim 23, wherein the variable intensity light sources are lasers.

25. The system as claimed in any one of claim 22-24, wherein the illuminating optic components comprise at least one moveable mirror for directing the beam to the plurality of illumination points.

26. The system as claimed in claim 25, wherein the moveable mirror is a mirror galvanometer.

27. The system as claimed in claim 26 further comprising a thin angled mirror located optically downstream of the mirror galvanometer.

28. The system as claimed in claim 27, wherein a lens is positioned between the mirror galvanometer and the thin angled mirror and optically coupled therewith to provide a telecentric imaging configuration.

29. The system as claimed in any one of claim 22-28, wherein the collecting optic components comprise a lens located above the region of interest and having a focal point coincident with the collection point.

30. The system as claimed in claim 29, wherein the collecting optic components further comprise a mirror galvanometer for directing the collected light to the detector.

31. The system as claimed in claim 30, wherein the mirror galvanometers of the illumination optic and collection optic are synchronized so as to provide a fixed distance between the illumination points and respective detection points.

32. The system as claimed in claim 30, wherein the mirror galvanometers of the illumination optic and collection optic are independently adjustable so as to provide a variable distance between the illumination points and respective detection points.

33. The system as claimed in any one of claim 22-32, wherein the illumination optics, the detection optics and the source are part of a gantry that can be rotated around the animal.

34. The system as claimed in any one of claim 22-33, further comprising a translational stage for moving a tray in a plane perpendicular to the illuminating beam wherein the tray is for supporting an animal.

35. The system as claimed in claim 34, wherein the tray is controllably heated to a desired temperature suitable for said animal.

36. The system as claimed in any one of claim 22-35, wherein the detector is a time correlated single photon counting detector.

37. The system as claimed in any one of claim 22-35, wherein the detector is a time gated ICCD.

38. The system as claimed in any one of claim 22-37, wherein the animal, the optical components and the detector are contained in an enclosure.

39. The system as claimed in claim 39, wherein the enclosure is light tight.

1/5

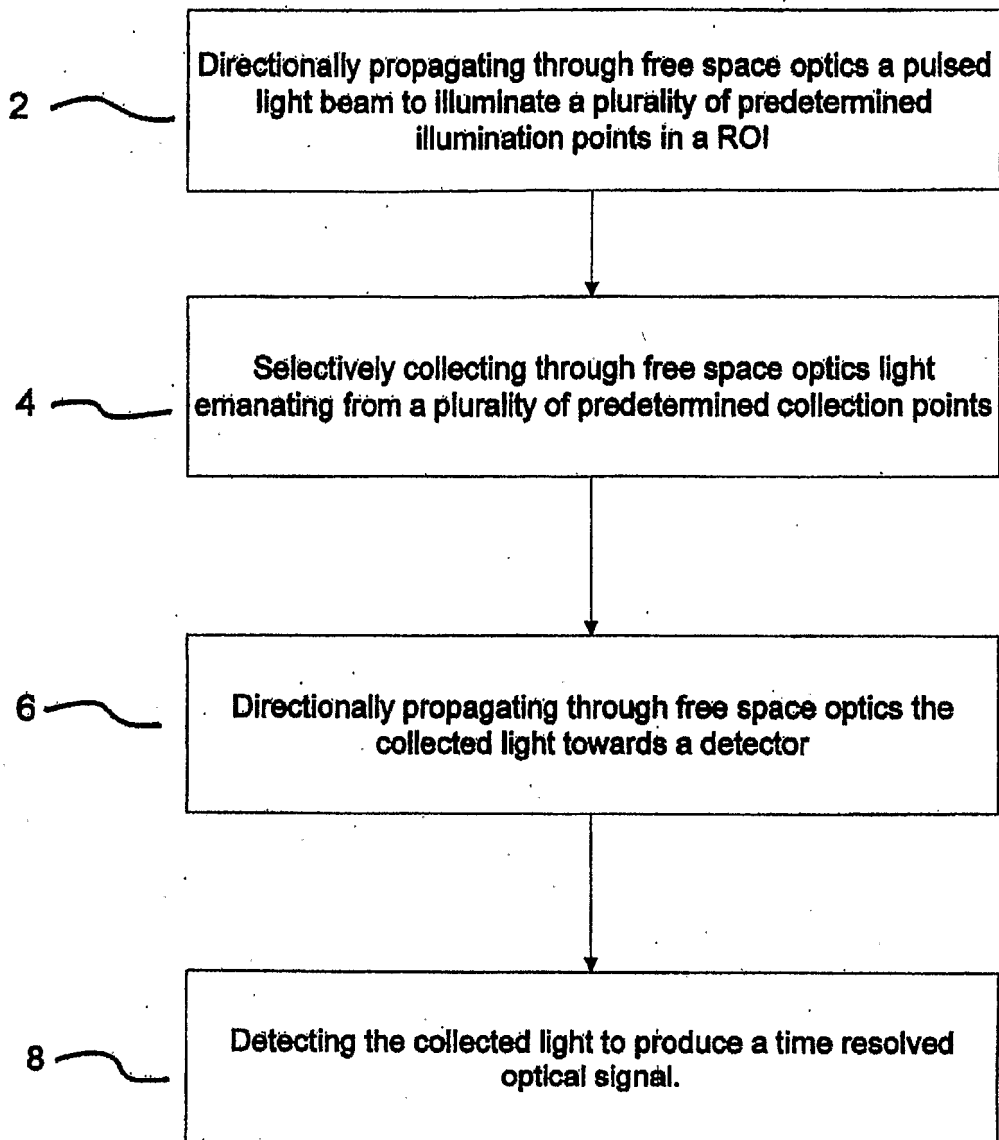

Fig. 1

3/5

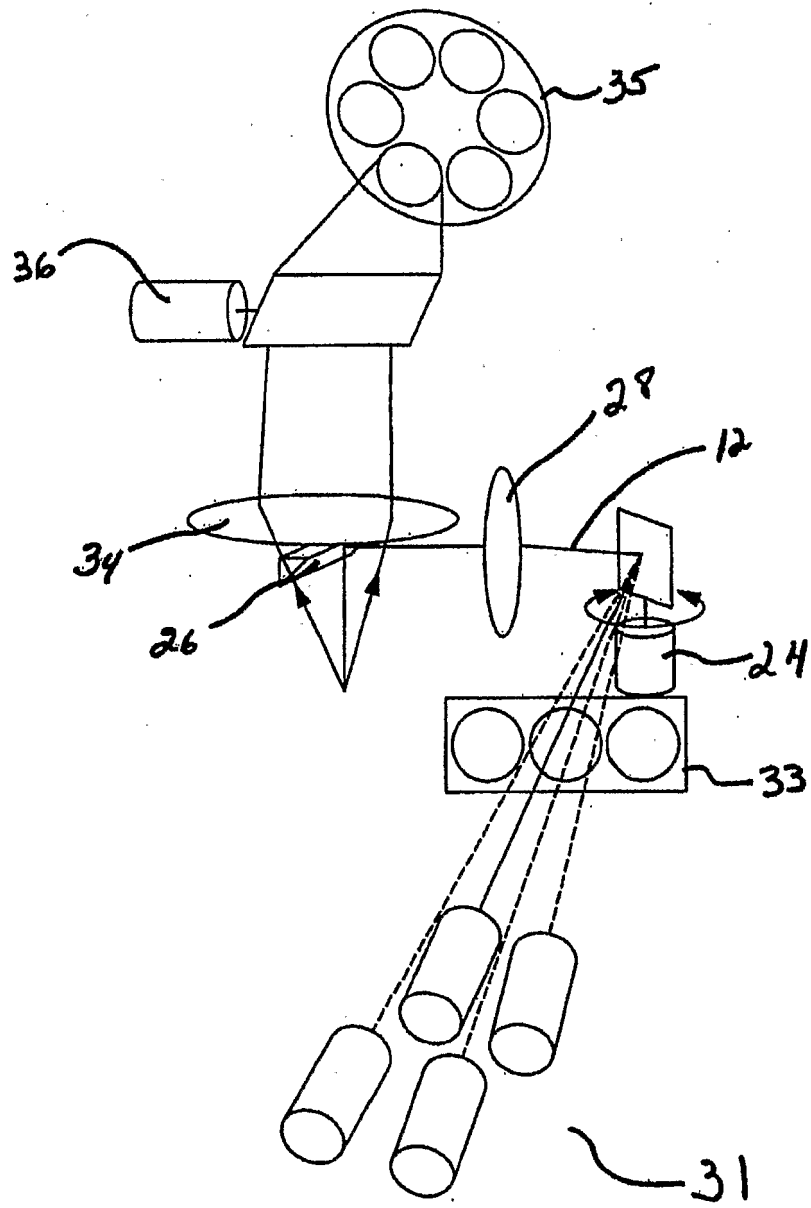

Fig-3

4/5

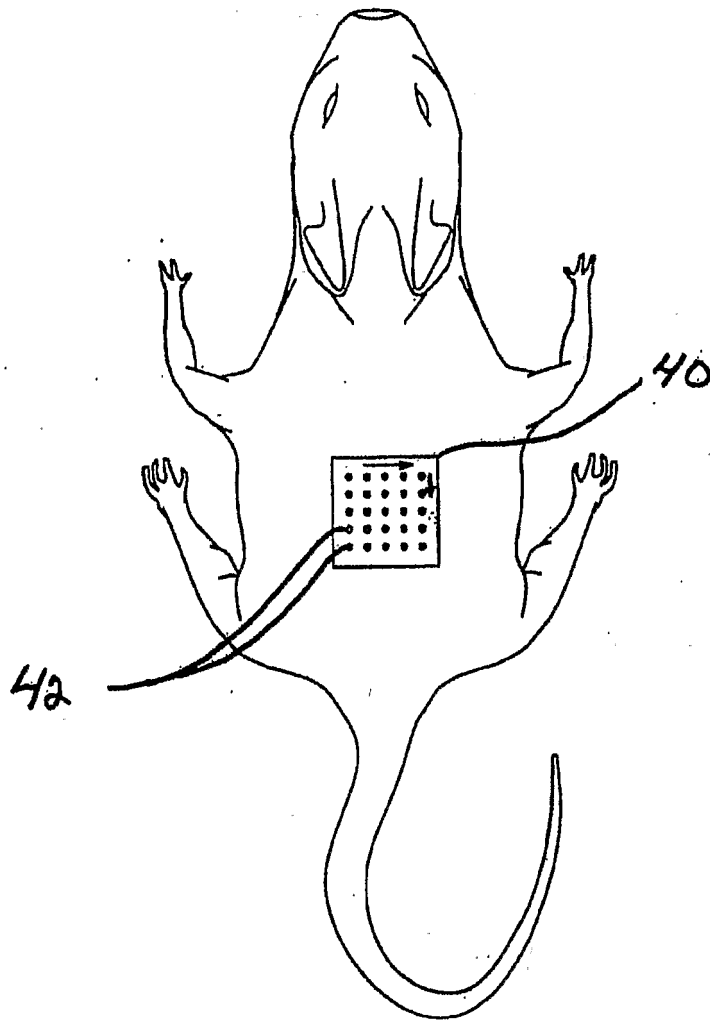

FIG- 4

5/5

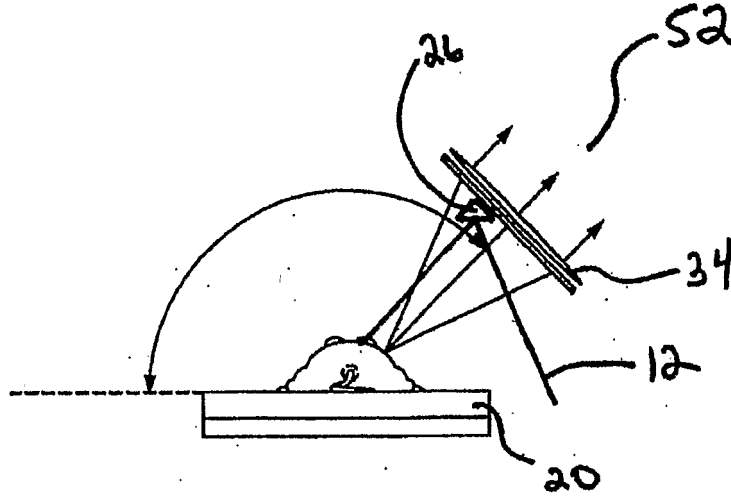

FIG. 5

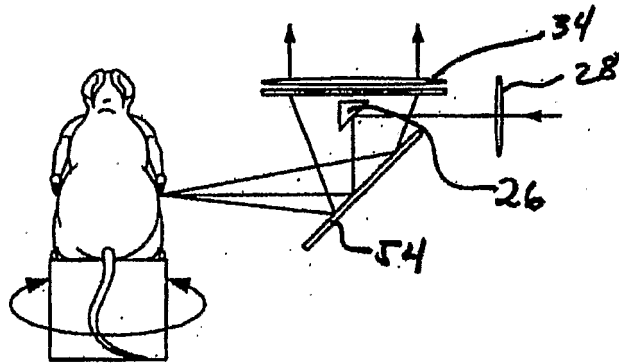

FIG. 6

INTERNATIONAL SEARCH REPORT

International Application No
PCT/CA 03/01705

A. CLASSIFICATION OF SUBJECT MATTER
 IPC 7 G01N21/47 G01N21/49 A61B5/00 G02B26/10 G01N33/483
 A61K49/00

According to International Patent Classification (IPC) or to both national classification and IPC

B. FIELDS SEARCHED
 Minimum documentation searched (classification system followed by classification symbols)
 IPC 7 G01N A61B G02B A61K

Documentation searched other than minimum documentation to the extent that such documents are included in the fields searched

Electronic data base consulted during the international search (name of data base and, where practical, search terms used)
 EPO-Internal, WPI Data, PAJ, IBM-TDB, INSPEC

C. DOCUMENTS CONSIDERED TO BE RELEVANT		
Category °	Citation of document, with indication, where appropriate, of the relevant passages	Relevant to claim No.
X	EP 0 760 477 A (HAMAMATSU PHOTONICS KK) 5 March 1997 (1997-03-05)	1, 2, 8, 9, 13-17, 19, 22, 29, 37
Y	page 9, line 19 -page 10, line 26; figure 8	3-7, 21, 23-28, 30, 31, 33-36, 38, 39
	--- -/--	

Further documents are listed in the continuation of box C. Patent family members are listed in annex.

° Special categories of cited documents :

<p>"A" document defining the general state of the art which is not considered to be of particular relevance</p> <p>"E" earlier document but published on or after the international filing date</p> <p>"L" document which may throw doubts on priority claim(s) or which is cited to establish the publication date of another citation or other special reason (as specified)</p> <p>"O" document referring to an oral disclosure, use, exhibition or other means</p> <p>"P" document published prior to the international filing date but later than the priority date claimed</p>	<p>"T" later document published after the international filing date or priority date and not in conflict with the application but cited to understand the principle or theory underlying the invention</p> <p>"X" document of particular relevance; the claimed invention cannot be considered novel or cannot be considered to involve an inventive step when the document is taken alone</p> <p>"Y" document of particular relevance; the claimed invention cannot be considered to involve an inventive step when the document is combined with one or more other such documents, such combination being obvious to a person skilled in the art.</p> <p>"&" document member of the same patent family</p>
--	--

Date of the actual completion of the international search 19 February 2004	Date of mailing of the international search report 03/03/2004
--	---

Name and mailing address of the ISA European Patent Office, P.B. 5818 Patentlaan 2 NL - 2280 HV Rijswijk Tel. (+31-70) 340-2040, Tx. 31 651 epo nl, Fax: (+31-70) 340-3016	Authorized officer Duijs, E
--	---

INTERNATIONAL SEARCH REPORT

International Application No

PCT/CA 03/01705

C.(Continuation) DOCUMENTS CONSIDERED TO BE RELEVANT

Category °	Citation of document, with indication, where appropriate, of the relevant passages	Relevant to claim No.
X	WO 02 056765 A (UNIV LONDON ;GEN HOSPITAL CORP (US)) 25 July 2002 (2002-07-25)	1, 2, 8, 9, 13, 14, 19, 20, 22
Y	page 7, line 22 - line 24	3-7, 21, 23-28, 30, 31, 33-36, 38, 39
	page 18, line 12 - line 17	
	page 19, line 26 -page 21, line 30	
X	EP 0 385 608 A (HITACHI LTD) 5 September 1990 (1990-09-05)	1, 2, 9, 10, 13, 14, 18-20, 22
Y	column 4, line 18 -column 10, line 54; figure 1	3-7, 21, 23-28, 30, 31, 33-36, 38, 39
Y	WO 02 27300 A (AMERSHAM PHARM BIOTECH UK LTD ;SHARMA SHIV (GB)) 4 April 2002 (2002-04-04)	3-7, 23-28, 33, 34, 36, 38, 39
	page 1, line 22 - line 35	
	page 4, line 14 -page 9, line 2; figure 1	
	page 10, line 7 - line 15	
A	WO 02 41760 A (NTZIACHRISTOS VASILIS ;GEN HOSPITAL (US); WEISSLEDER RALPH (US)) 30 May 2002 (2002-05-30)	1, 3, 4, 8, 9, 13-17, 19, 20, 22, 24, 36, 37
	the whole document	
Y	PATENT ABSTRACTS OF JAPAN vol. 2002, no. 06, 4 June 2002 (2002-06-04) & JP 2002 051662 A (JAPAN SCIENCE & TECHNOLOGY CORP), 19 February 2002 (2002-02-19) abstract	21, 35
Y	US 2002/141051 A1 (SZULCZEWSKI MICHAEL J ET AL) 3 October 2002 (2002-10-03)	30, 31
A	paragraphs '0002!', '0032!', '0035!', '0036!'; figure 3	10-12, 16, 25, 26, 28, 29

INTERNATIONAL SEARCH REPORT

Information on patent family members

International Application No

PCT/CA 03/01705

Patent document cited in search report	A	Publication date		Patent family member(s)	Publication date
EP 0760477	A	05-03-1997		JP 9061359 A	07-03-1997
				EP 0760477 A2	05-03-1997
				US 5772588 A	30-06-1998
WO 02056765	A	25-07-2002		CA 2434283 A1	25-07-2002
				EP 1349493 A2	08-10-2003
				WO 02056765 A2	25-07-2002
				US 2003030809 A1	13-02-2003
EP 0385608	A	05-09-1990		EP 0385608 A1	05-09-1990
				JP 2290534 A	30-11-1990
				JP 2956777 B2	04-10-1999
				US 5148022 A	15-09-1992
WO 0227300	A	04-04-2002		AU 9202201 A	08-04-2002
				WO 0227300 A1	04-04-2002
				US 2004012780 A1	22-01-2004
WO 0241760	A	30-05-2002		US 6615063 B1	02-09-2003
				AU 2867302 A	03-06-2002
				CA 2428462 A1	30-05-2002
				EP 1349490 A2	08-10-2003
				WO 0241760 A2	30-05-2002
				US 2004015062 A1	22-01-2004
JP 2002051662	A	19-02-2002		NONE	
US 2002141051	A1	03-10-2002		NONE	

专利名称(译)	用于作为动物一部分的生物组织的时间分辨光学成像的方法和设备		
公开(公告)号	EP1563281A1	公开(公告)日	2005-08-17
申请号	EP2003773381	申请日	2003-11-10
[标]申请(专利权)人(译)	阿特艾得凡科技研究公司		
申请(专利权)人(译)	ART高级研究科技股份有限公司.		
当前申请(专利权)人(译)	SOFTSCAN HEALTHCARE GROUP LTD.		
[标]发明人	LONG WILLIAM F BERUBE LAUZIÈRE YVES HALL DAVID J MCINTOSH LAURA		
发明人	LONG, WILLIAM, F. BERUBE-LAUZIÈRE, YVES HALL, DAVID, J. MCINTOSH, LAURA		
IPC分类号	A61B5/00 A61K49/00 G01N21/47 G01N21/49 G01N33/483 G02B26/10		
优先权	60/665297 2003-09-22 US 10/505352 2002-12-12 US PCT/IB2002/004698 2002-11-11 WO		
外部链接	Espacenet		

摘要(译)

提供了一种用于收集用于时间分辨光学成像的光学数据的方法和系统，其中脉冲光通过自由空间光学器件（24,26,28,29）定向传播以照射在表面上的多个照射。生物组织（14），例如包含在小动物中的生物组织。从组织重新发射的光被收集并通过自由空间光学器件（34,36,38）朝向检测器（18）定向传播，以产生对光学图像重建有用的时间分辨光学信号。