

(19) World Intellectual Property Organization
International Bureau



(43) International Publication Date
27 December 2002 (27.12.2002)

PCT

(10) International Publication Number
WO 02/102224 A2

- (51) International Patent Classification⁷: **A61B**
- (21) International Application Number: PCT/IL02/00480
- (22) International Filing Date: 18 June 2002 (18.06.2002)
- (25) Filing Language: English
- (26) Publication Language: English
- (30) Priority Data:
60/298,387 18 June 2001 (18.06.2001) US
- (71) Applicant (for all designated States except US): **GIVEN IMAGING LTD.** [IL/IL]; HaCarmel St. 2, Industrial Park, 20692 Yoqneam (IL).
- (72) Inventor; and
- (75) Inventor/Applicant (for US only): **AVNI, Dov** [IL/IL]; Succot Street 7, 34525 Haifa (IL).
- (74) Agents: **PEARL, Zeev** et al.; Eitan, Pearl, Latzer & Cohen-Zedek, Gav Yam Center 2, Shenkar Street 7, 46725 Herzlia (IL).
- (81) Designated States (national): AE, AG, AL, AM, AT, AU, AZ, BA, BB, BG, BR, BY, BZ, CA, CH, CN, CO, CR, CU, CZ, DE, DK, DM, DZ, EC, EE, ES, FI, GB, GD, GE, GH, GM, HR, HU, ID, IL, IN, IS, JP, KE, KG, KP, KR, KZ, LC, LK, LR, LS, LT, LU, LV, MA, MD, MG, MK, MN, MW, MX, MZ, NO, NZ, OM, PH, PL, PT, RO, RU, SD, SE, SG, SI, SK, SL, TJ, TM, TN, TR, TT, TZ, UA, UG, US, UZ, VN, YU, ZA, ZM, ZW.
- (84) Designated States (regional): ARIPO patent (GH, GM, KE, LS, MW, MZ, SD, SL, SZ, TZ, UG, ZM, ZW), Eurasian patent (AM, AZ, BY, KG, KZ, MD, RU, TJ, TM), European patent (AT, BE, CH, CY, DE, DK, ES, FI, FR, GB, GR, IE, IT, LU, MC, NL, PT, SE, TR), OAPI patent (BF, BJ, CF, CG, CI, CM, GA, GN, GQ, GW, ML, MR, NE, SN, TD, TG).
- Published:**
— without international search report and to be republished upon receipt of that report
- For two-letter codes and other abbreviations, refer to the "Guidance Notes on Codes and Abbreviations" appearing at the beginning of each regular issue of the PCT Gazette.



WO 02/102224 A2

(54) Title: IN VIVO SENSING DEVICE WITH A CIRCUIT BOARD HAVING RIGID SECTIONS AND FLEXIBLE SECTIONS

(57) Abstract: A device including at least one image sensor and a circuit board having a plurality of rigid sections and a plurality of flexible sections. The image sensor is disposed on a rigid section of the circuit board. The circuit board may be folded into a housing configured for in vivo sensing.

IN VIVO SENSING DEVICE WITH A CIRCUIT BOARD HAVING RIGID SECTIONS AND FLEXIBLE SECTIONS

5

FIELD OF THE INVENTION

The present invention relates to an in vivo imaging device and system such as for imaging the digestive tract.

10

BACKGROUND OF THE INVENTION

In vivo imaging may include the use of an in vivo imager from which image data may be transmitted to an external receiving system. For example, an ingestible capsule comprising an image sensor and a transmitter for transmitting image data may be used for imaging the gastrointestinal (GI) tract. In some ingestible capsules the electronic components within the capsule may be arranged on several boards, each board containing different components of the capsule, for example, the image sensor, typically a silicon chip, may be positioned on one board whereas the transmitter may be positioned on a separate printed circuit board (PCB). In some cases the boards are aligned along an axis of the capsule and are electrically connected by a plurality of wires. Assembly of capsules having several boards connected by wires may be complex and may hinder, for example, large scale production.

20

SUMMARY OF THE INVENTION

Thus, the present invention provides, according to some embodiments an in vivo sensing device comprising a circuit board having a plurality of rigid sections and a plurality of flexible sections. According to one embodiment the rigid sections and flexible sections alternate. Optionally, the in vivo sensing device may include at least an image sensor. According to another embodiment the device may also include a transmitter for transmitting signals from a sensor, such as an imaging camera, to a receiving system. In one embodiment various components in the device, such as the image sensor and transmitter, are disposed on different rigid circuit board sections. Preferably, the circuit board is folded and arranged in a stacked vertical fashion. In a further embodiment, the various rigid portions may be connected by vertical connectors such as springs.

15

BRIEF DESCRIPTION OF THE DRAWINGS

The present invention will be understood and appreciated more fully from the following detailed description taken in conjunction with the drawings in which:

Figure 1 schematically illustrates an in vivo imaging device according to one embodiment of the invention;

20

Figures 2A and 2B schematically illustrate possible folding of the circuit board according to two embodiments of the invention; and

Figure 3 schematically illustrates an in vivo imaging device according to a third embodiment of the invention.

DETAILED DESCRIPTION OF THE INVENTION

In the following description, various aspects of the present invention will be described. For purposes of explanation, specific configurations and details are set forth
5 in order to provide a thorough understanding of the present invention. However, it will also be apparent to one skilled in the art that the present invention may be practiced without the specific details presented herein. Furthermore, well-known features may be omitted or simplified in order not to obscure the present invention.

The system and method of the present invention may be used with an imaging
10 system such as that described in WO 01/65995. A further example of an imaging system with which the system and method of the present invention may be used is described in U.S. Patent No. 5,604,531 to Iddan et al. Both these publications are assigned to the common assignee of the present application and are hereby incorporated by reference. Alternatively, the system of the present invention may be
15 utilized in any suitable imaging device providing images of a body lumen or cavity. For example, a circuit board according to an embodiment of the invention may be utilized in probes used for in vivo imaging, such as endoscopes.

Reference is now made to Fig. 1, which schematically illustrates an in vivo imaging device according to an embodiment of the invention. The device 10 typically
20 comprises an optical window 21 and an imaging system for obtaining images from inside a body lumen, such as the GI tract. The imaging system includes an illumination source 23, such as a white LED, a CMOS imaging camera 24, which detects the images and an optical system 22 which focuses the images onto the CMOS image sensor 24. The illumination source 23 illuminates the inner portions of the body lumen through
25 optical window 21. Device 10 further includes a transmitter 26 and an antenna 27 for transmitting image signals from the CMOS image sensor 24, and a power source 25, such as a silver oxide battery, that provides power to the electrical elements of the device 10. A suitable CMOS image sensor 24 is, for example, a "camera on a chip"

type CMOS imager specified by Given Imaging Ltd. of Yokneam, Israel and designed by Photobit Corporation of California, USA, The single chip camera can provide either black and white or color signals. A suitable transmitter may comprise a modulator which receives the image signal (either digital or analog) from the CMOS imaging camera, a radio frequency (RF) amplifier, an impedance matcher and an antenna. A processor, e.g., for processing the image data may be included in the device. The processor or processing circuitry may be integrated in the sensor or in the transmitter.

The device 10 is capsule shaped and can operate as an autonomous endoscope for imaging the GI tract. However, other devices, such as devices designed to be incorporated in an endoscope, catheter, stent, needle, etc., may also be used, according to embodiments of the invention. Furthermore, the device 10 need not include all the elements described above. For example, the device 10 need not include an internal light source or an internal power source; illumination and/or power may be provided from an external source, as known in the art.

According to one embodiment of the invention, the various components of the device 10 are disposed on a circuit board including rigid and flexible portions; preferably the components are arranged in a stacked vertical fashion. For example, one rigid portion 31 of the circuit board may hold a transmitter and an antenna; preferably the antenna is at one end of the capsule to avoid screening of the signal by metal or other components in the capsule. Another rigid portion 33 of the circuit board includes an LED 23 lighting system and an imager 24 on one side; the other side of this rigid portion 33 includes a battery 25 contact. The battery contact is preferably a spring, described below. Another rigid portion 35 of the circuit board includes another battery contact. Each rigid portion of the circuit board is connected to another rigid portion of the circuit board by a flexible connector portion (e.g. 32 and 32') of the circuit board. Preferably, each rigid portion of the circuit board comprises two rigid sections; sandwiched between the rigid sections is a flexible connector portion of the circuit board for connecting the rigid boards. In alternate embodiments, other arrangements of components may be placed on a circuit board

having rigid portions connected by flexible portions.

In alternate embodiments, a circuit board having rigid portions and flexible portions may be used to arrange and hold components in other in vivo sensing devices, such as a swallowable capsule measuring acidity (having a pH sensor (, temperature or pressure, or in a swallowable imaging capsule having components other than those described above.

Preferably, each flexible connector portion is equal to or less than 4/1000 inch (4 mils) in thickness. Preferably, electrical connection is made from the outside portion of a rigid portion board (on which components are mounted) to the inside of the rigid portion and to the flexible portion contained within, by a small (equal to or less than 4 mils in diameter) hole leading from the outside portion to the flexible portion – a micro-via. Preferably the micro-via is created using a laser. Companies providing such flexible connector and micro-via technology are Eltech, of Petach-Tikva, Israel, and Ilfa, of Germany. In alternate embodiments, other types of rigid sections and flexible sections may be used to create a circuit board.

The circuit board may be folded, for example, as shown in Figs. 2A and 2B. When folded, the battery contacts contact a set of one or more batteries, which are sandwiched between two rigid circuit board portions. The circuit board may be folded in various manners. For example, Fig. 2A schematically shows a circuit board, according to an embodiment of the invention, arranged as an “S” with rigid portions 31, 35 and 33 and alternating flexible portions 32 and 32'. A set of batteries 25 may be sandwiched between one lobe 38 of the S. Another configuration, according to an embodiment of the invention is schematically shown in Fig. 2B. The circuit board, according to an embodiment of the invention may be in the shape of a “6” with rigid portions 31, 35 and 33 and alternating flexible portions 34 and 34. A set of batteries 25 may be positioned in the closed configuration 38' of the “6”.. Other configurations are possible. In alternate embodiments, batteries may be connected in different manners, or need not be used.

Preferably, a very thin flexible section is needed due to the radius of the

diameter of the turns, given the size of the capsule, and also because the flexible section may be disposed between components, such as between the set of batteries and the side of the capsule. Preferably, the radius of the turn should be more than 6 or 10 times the thickness. In alternate embodiments, the rigid boards and flexible
5 connectors may be of other dimensions.

In one embodiment, the rigid portions of the circuit board may include any sort of known material; preferably FR4 flexiglass is used. The flexible portions may include any sort of known material; preferably, Kapton™ by DuPont is used.

Reference is made to Figure 3, which schematically illustrates another view
10 of an embodiment of the invention. According to one embodiment, a vertical physical and electrical connection may be made between rigid portions of the circuit board. For example, the rigid portion 51 holding the LED 23 (which is preferably in the shape of a ring) may be connected physically and electrically to another rigid portion apart from being connected by flexible portion 57. In one embodiment, mini springs
15 56 are used to connect a power supply from one circuit rigid portion 53 to the rigid portion 51 holding the LED 23. Such springs 56 have two functions; to mechanically connect the two rigid portions (e.g., 51 and 53) and also to conduct current between the two rigid portions. Preferably, the springs are glued to the two rigid portions, and current flows between two rigid portions.

20 In addition, a vertical connection is made between the set of batteries 25 and two rigid portions by springs 58. Each contact spring 58 is preferably a conical spring, which, as it shrinks, allows each circle or coil of the spring to enter a larger encircling coil. Thus, when fully shrunken, the final thickness of the spring is thickness of a single circle of conductor wire.

25 There is also provided a method for the manufacture of a in vivo sensor, in accordance with an embodiment of the invention. The method includes the steps of disposing at least a sensor on a rigid section of a circuit board having a plurality of rigid

sections and a plurality of flexible sections and folding the circuit board into a housing configured for in vivo sensing.

- 5 It will be appreciated by persons skilled in the art that the present invention is not limited to what has been particularly shown and described hereinabove. Rather the scope of the present invention is defined only by the claims which follow:

CLAIMS

1. An in vivo sensing device comprising a circuit board having a plurality of rigid sections and a plurality of flexible sections.
2. The device according to claim 1 and also comprising a sensor.
- 5 3. The device according to claim 2 wherein the sensor is an image sensor.
4. The device according to claim 2 wherein the sensor is selected from the group consisting of a pH sensor, a temperature sensor and a pressure sensor.
5. The device according to claim 1 further comprising an image sensor.
6. The device according to claim 2 and also comprising a transmitter.
- 10 7. The device according to claim 1 further comprising at least one component selected from the group consisting of an illumination source, a power source, a sensor, a processor, a transmitter or a combination thereof.
8. The device according to claim 7 wherein at least one component is disposed on at least one rigid section of the circuit board.
- 15 9. The device according to claim 7 wherein a plurality of components are disposed on a plurality of rigid sections of the circuit board.
10. The device according to claim 6 wherein the sensor is disposed on a rigid section of the circuit board and the transmitter is disposed on another rigid section of the circuit board.

11. The device according to claim 1 wherein the rigid sections alternate with the flexible sections.
12. The device according to claim 1 wherein the circuit board is folded such that the rigid sections of the circuit board are stacked vertically.
- 5 13. The device according to claim 1 wherein the rigid sections are connected by vertical connectors.
14. The device according to claim 13 wherein the vertical connectors are electrical conductors.
15. The device according to claim 13 wherein the vertical connectors are springs.
- 10 16. The device according to claim 15 wherein the springs are conical springs.
17. The device according to claim 1 wherein the circuit board includes flexiglass.
18. The device according to claim 9 wherein the components are electrically connected through micro-via in the rigid sections.
19. A method for the manufacture of an in vivo sensor, the method comprising the
- 15 steps of:
- disposing at least a sensor on a rigid section of a circuit board having a plurality of rigid sections and a plurality of flexible sections; and
 - folding the circuit board into a housing configured for in vivo sensing.

20. The method according to claim 19 wherein the step of folding the circuit board includes folding the circuit board such that the rigid sections of the circuit board are stacked vertically.
21. A device comprising at least one in vivo sensor and a circuit board having a plurality of rigid sections and a plurality of flexible sections, wherein the sensor is disposed on at least one rigid section of the circuit board.
22. A device comprising at least one image sensor and a circuit board having a plurality of rigid sections and a plurality of flexible sections, wherein the image sensor is disposed on at least one rigid section of the circuit board.
23. The device according to claim 22 further comprising a transmitter for transmitting image signals, said transmitter disposed on another rigid section of the circuit board.

1/2

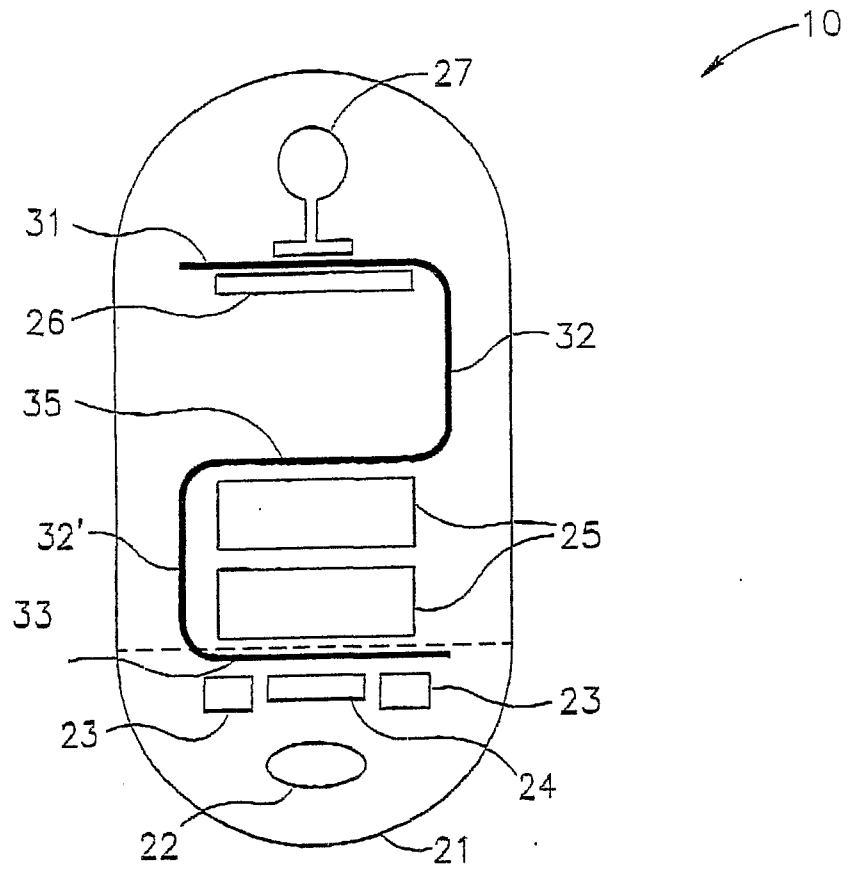

FIG. 1

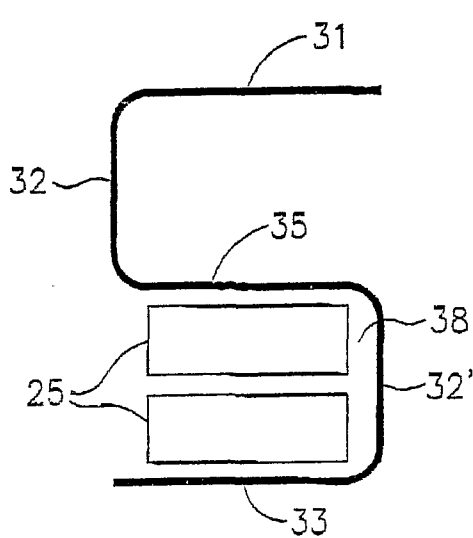

FIG. 2A

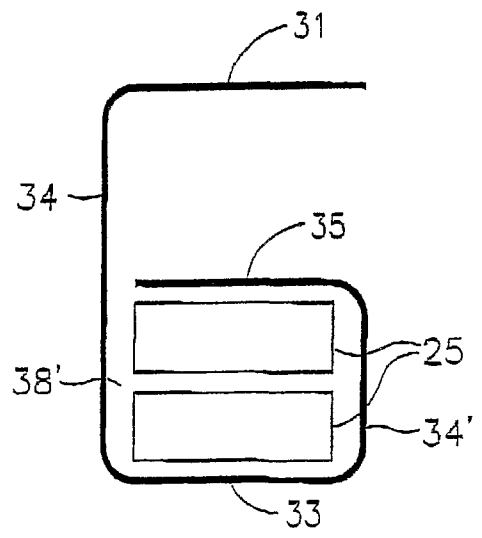

FIG. 2B

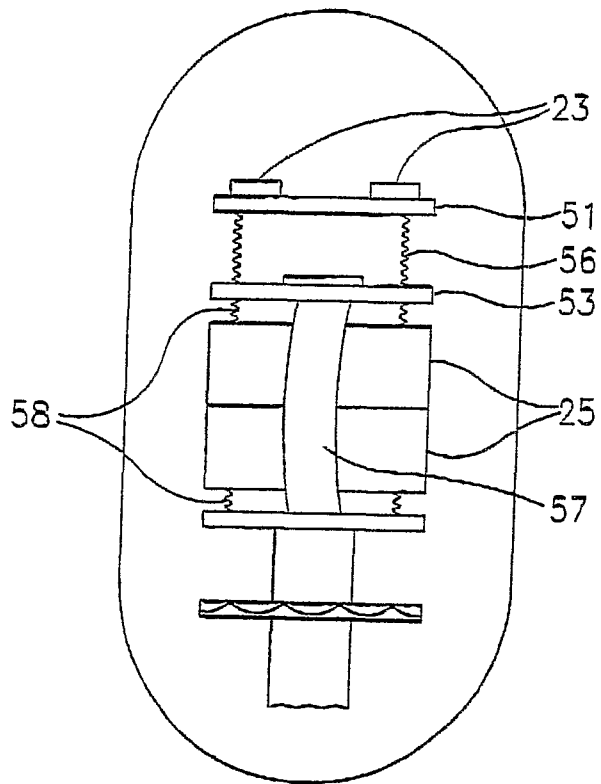

FIG.3

专利名称(译)	具有电路板的体内传感装置具有刚性部分和柔性部分		
公开(公告)号	EP1418833A2	公开(公告)日	2004-05-19
申请号	EP2002738602	申请日	2002-06-18
[标]申请(专利权)人(译)	基文影像公司		
申请(专利权)人(译)	基文影像有限公司.		
当前申请(专利权)人(译)	基文影像有限公司.		
[标]发明人	AVNI DOV		
发明人	AVNI, DOV		
IPC分类号	A61B5/01 A61B5/07 A61B1/00 A61B1/04 A61B1/05 A61B5/00 H05K1/00 H05K1/18		
CPC分类号	A61B5/0031 A61B1/041 H05K1/189 H05K3/3436 H05K2201/10151 Y02P70/613		
代理机构(译)	格拉夫WERNER		
优先权	60/298387 2001-06-18 US		
其他公开文献	EP1418833B1 EP1418833A4		
外部链接	Espacenet		

摘要(译)

一种装置，包括至少一个图像传感器和电路板（图1），该电路板具有多个刚性部分和多个柔性部分。图像传感器设置在电路板的刚性部分上。电路板可以折叠成配置用于体内感测的外壳。