

(19) World Intellectual Property Organization
International Bureau



(43) International Publication Date
14 December 2000 (14.12.2000)

PCT

(10) International Publication Number
WO 00/74561 A1

- (51) International Patent Classification⁷: **A61B 5/00** 1556 Wellington Avenue, Grand Junction, CO 81501 (US).
CURTIS, Robert, M.; 1320 Brandt Road, Hillsborough, CA 94010 (US).
- (21) International Application Number: PCT/US00/15495
- (22) International Filing Date: 5 June 2000 (05.06.2000) (74) Agents: **HANN, James, F.** et al.; Haynes & Beffell LLP, 751 Kelly Street, P.O. Box 366, Half Moon Bay, CA 94019 (US).
- (25) Filing Language: English
- (26) Publication Language: English (81) Designated State (national): JP.
- (30) Priority Data: (84) Designated States (regional): European patent (AT, BE, CH, CY, DE, DK, ES, FI, FR, GB, GR, IE, IT, LU, MC, NL, PT, SE).
- | | | |
|------------|--------------------------------|----|
| 60/137,775 | 4 June 1999 (04.06.1999) | US |
| 09/336,360 | 18 June 1999 (18.06.1999) | US |
| 60/146,892 | 2 August 1999 (02.08.1999) | US |
| 60/154,394 | 17 September 1999 (17.09.1999) | US |
| 60/200,546 | 27 April 2000 (27.04.2000) | US |
- (71) Applicant: **ARTEMIS MEDICAL, INC.** [US/US]; Suite 303, 655 Mariners Island Boulevard, San Mateo, CA 94404 (US).
- (72) Inventors: **DUBRUL, William, R.**; 1 Uccelli Boulevard, Redwood City, CA 94063 (US). **FULTON, Richard, E.**;
- Published:**
— With international search report.
— Before the expiration of the time limit for amending the claims and to be republished in the event of receipt of amendments.

For two-letter codes and other abbreviations, refer to the "Guidance Notes on Codes and Abbreviations" appearing at the beginning of each regular issue of the PCT Gazette.

(54) Title: TISSUE REMOVAL METHODS AND APPARATUS

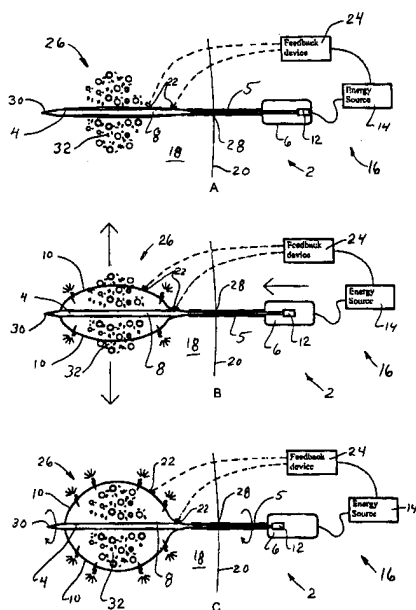

(57) Abstract: Target tissues are accessed, removed using various types of devices, and methods. One such device includes a support shaft (2), introducer sheath (5), handle (6), separation wires (10), slide (12), energy source (14), and feedback device (24).



WO 00/74561 A1

efforts to remove cancerous tissue in less invasive ways continue, but have not yet been perfected.

The only cure for cancer continues to be the early diagnosis and subsequent early treatment. As cancer therapies continue at earlier stages of diagnosis, the cancerous tissue being operated on is also smaller. Early removal of the smaller cancers demand new techniques for removal and obliteration of these less invasive cancers.

There are a variety of techniques that attempt to accomplish less invasive cancer therapy, but so far without sufficiently improved results. For example, the ABBI system from U.S. Surgical Corporation and the Site Select system from Imagine Corporation, attempt to accomplish less invasive cancer therapy. However, conventional techniques require more than Minimally Invasive Surgery (MIS) techniques in that they require a large core (that is more than about 15mm diameter) incision. Additionally, the Mammotome system from Johnson and Johnson and MIBB system from U.S. Surgical Corporation also require large core (over about 4mm diameter) access to accomplish biopsy.

A recent convention held by the American Society of Surgical Oncologists on March 13, 2000 reported that conventional stereotactic core biopsy (SCB) procedures fall short in providing definitive answers to detail precise surgical regimens after this SCB type vacuum assisted biopsy, especially with ductile carcinoma in situ (DCIS). Apparently these percutaneous systems damage "normal" tissue cells so that it is difficult to determine if the cells are "normal damaged" cells or early pre-cancerous (e.g. Atypical Ductal Hyperplasia (ADH)) cells.

A study presented by Dr. Ollila et al. from the University of North Carolina, Chapel Hill, demonstrated that histology and pathology is compromised using these conventional techniques because of the damage done to the removed tissue specimens. Hence, for many reasons, including the fact that DCIS is becoming more detectable and hence more prevalent in breast cancer diagnosis in the U.S., there is a growing need to improve upon conventional vacuum assisted core biopsy systems.

30

SUMMARY OF THE INVENTION

Broadly, the present invention is directed to procedures, including biopsy and tumorectomy methods, and associated apparatus which provide for less invasive techniques while also providing for enhanced tissue specimens being retrieved.

A first aspect of the invention is directed to a tissue removal method in which a tissue separation device is positioned at a target site within a patient. A tissue sample is separated by the movement of tissue separation element through the tissue at the target site. A factor relating to the restriction of the passage of the tissue separation element through the tissue is monitored so that energy supplied to the tissue separation element can be adjusted. The procedure may be carried out percutaneously. The method may include radially expanding one or more heated, wire-type tissue separation elements and then rotating the support shaft. The factor being monitored may include, for example, strain on the tissue separation element, the rotational force supplied to the device, the pressure exerted against the tissue by the tissue separation element, etc. Monitoring may also be done manually with tactile feedback to the user.

A related aspect of the invention is directed to a tissue removal assembly in which an elongate tissue separation device comprises a tissue separation element mounted to a support. The tissue separation element is movable from a retracted state to an extended state. A tissue separation element driver is operably coupled to the tissue separation element to permit the tissue separation element to separate a target tissue mass from a patient. The tissue separation element driver comprises an energy source coupled to the tissue separation device. A sensor is operably coupled to at least one of the tissue separation device and the tissue separation element driver and senses resistance to the separation of the target tissue mass from the patient. A feedback device operably couples the sensor and the tissue separation element driver so that the amount of energy supplied can be adjusted based on the resistance to the passage of the tissue separation element through the patient's tissue.

Certain advantages accrue through the use of the above-described tissue removal method and assembly. An appropriate amount of energy can be supplied to the tissue separation element so that when, for example, the tissue separation element is a wire which extends radially outwardly to form an arch passing through the target tissue, the wire can be heated so to cauterize the tissue it passes through as it moves from the radically retracted state to the radically extended state; this helps to prevent spreading of viable cancer tissue into non-cancerous tissue regions. Heating or otherwise energizing the tissue separation element with RF energy, vibrational or other mechanical energy, etc., may also reduce the force required to move the tissue separation element through tissue mass, especially when passing through dense or fibrotic tissue or a variation in densities. Once the tissue separation element has been fully extended, it may or may not

need to be heated or otherwise energized to pass through non-diseased tissue surrounding the suspect tissue mass. Therefore, undesirable damage to healthy tissue may be minimized and the spread of cancerous tissue to non-cancerous tissue may be effectively eliminated.

5 A further aspect of the invention is directed to a method for helping to prevent seeding of a tissue tract including positioning a protective device along the tissue tract and then moving tissue from the target site, through an opening in the protective device and into an inner region of the protective device. The tissue is then moved along the tissue tract and out of the patient while keeping the tissue within the device. The
10 protective device may be maintained substantially in place along the tissue tract as the tissue is moved out of the patient.

 A still further aspect of the invention is directed to a tissue tract device comprising a tubular body sized to extend along a tissue tract between an access site and a site within the patient. The body includes a radially-enlarged proximal end, configured to
15 lie against the skin surface of the patient, and a distal end. The device may also include a tissue retrieval device positionable within the tubular body and having a distal part extendable through the distal end of the body.

 Another aspect of the invention is directed to a method for the percutaneous removal of tissue from a target site during which a hollow, radially
20 expandable/collapsible portion of an elongate member is passed through a tissue tract with the portion in a radially collapsed condition. The portion is then positioned at a chosen position relative to the target site, typically adjacent to the target site. Part or all of the portion is radially expanded and a tissue sample is taken from the target site and housed within the portion. The tissue sample is removed from the patient while
25 maintaining the tissue sample within the elongate member. The radially expanded part of the portion is at least partially collapsed and the at least partially collapsed portion is then removed from the patient. The tissue sample may be removed from the patient simultaneously with removal of the partially collapsed portion of the elongate member from the patient. Alternatively, the tissue sample may be removed from the patient prior
30 to removal of the partially collapsed portion of the elongate member from the patient. The collapsing of the part of the portion of the elongate member may act to radially compress the tissue sample housed therein prior to the removal of the tissue sample from the patient. This method permits minimizing the size of the access site in the patient's skin. Because the tissue sample is maintained in the elongate member during removal

from the patient, the tissue sample will not contaminate the tissue tract during such removal.

An additional aspect of the invention is directed to a percutaneous tissue sample removal assembly including an elongate member, at least a distal portion thereof being radially expandable/collapsible. The distal portion has an open interior and an open distal end. A tissue sample retrieval device is operable to position a tissue sample through the open distal end and into the open interior.

A further aspect of the invention is directed to a method for percutaneously removing an entire tissue mass sample in which an access opening is formed in the patient's skin; a target site is percutaneously accessed along a tissue tract connecting the access opening and the target site. The entire suspect tissue mass is simultaneously removed from the patient along the tissue tract. The steps of forming the access opening and simultaneously removing the entire suspect tissue mass are carried out so that the largest lateral dimension of the access opening is smaller than the largest lateral dimension of the suspect tissue mass prior to removal. The entire suspect tissue mass may be severed from adjacent tissue in at most three contiguous pieces. The suspect tissue mass may be monitored for disease, such as after being removed from the patient. Thus, pathology testing can be done immediately after removal of the entire suspect tissue mass. There is no need to wait for the removal of numerous tissue plugs as is done with conventional needle biopsy techniques. This method helps to ensure that the margins of the suspect tissue mass can be quickly and effectively tested for the presence of diseased tissue at the margins.

Another aspect of the invention is directed to percutaneous tissue mass retrieval assembly comprising a shaft, a radially expandable blocking element at the distal end of the shaft, a suspect tissue mass enveloping device movable from an enlarged, tissue mass-surrounding state to a contracted, tissue mass-constricting state so to enable the tissue mass to be removed from a target site with a reduced lateral size.

A still further aspect of the invention is directed to a method for maintaining access to a void within a patient by placing an access sleeve along a tissue tract connecting an access site in the patient's skin and a void in the patient. This method may take place, for example, following the removal of a biopsy specimen, the removal creating the void. The method may also take place following removal of an entire suspect tissue mass as well. This method ensures convenient and accurate re-access to the void

when, for example, an additional tissue sample is needed, therapeutic drugs are to be delivered to the void, a prosthesis is to be implanted, etc.

An additional aspect of the invention is directed to a method for removal of target material from a target site and includes percutaneously placing an expandable
5 blocking element at a first position distal of the target material, expanding the expandable blocking element, percutaneously placing a removing element at a second position, at least substantially surrounding the target material with the blocking element and the removing element, and then removing the blocking element, the removing element and the target material therewith from the patient along a tissue tract connecting the target site
10 with an access site in the patient's skin. The expandable blocking element may be a radially expandable, tubular mesh material. The removing element may include a tubular mesh element having a radially expandable, open distal end. One or both of the removing element and blocking element may be at least partially radially collapsed prior to removing the blocking element, removing element and target material therewith from the
15 patient. This method helps to ensure target material is properly captured and permits it to be removed percutaneously; the removal may be preceded by radially collapsing the blocking and/or removing elements to help reduce the size of the device passing through the access site in the patient's skin.

A still further aspect of the invention relates to a target material removing
20 device including a shaft, first and second axially spaced-apart, radially expandable elements carried by a distal portion of the shaft. The expandable elements are remotely selectively movable between radially retracted and radially expanded states so that the expandable elements can be used to bracket target material to permit the target material to be removed from the patient along with the device. This device permits a surgeon to
25 easily and accurately locate the target material, which is often very difficult to visually differentiate from surrounding tissue, by locating the expandable elements. The radially expandable elements are preferably sufficiently hard so as to be detectable by palpation.

A still another aspect to the invention is directed to a method for locating a
30 target mass within a patient comprising extending the distal end of a shaft to a position distal of a target mass, positioning first and second radially expanding bracketing elements at positions distal of and proximal of the target mass, moving the bracketing elements from radially retracted states to radially expanded states thereby bracketing the target mass, and locating a target mass using the bracketing elements. The bracketing elements, when radially expanded, may define a bracketed region therebetween sized to

completely contain the target mass. The target mass may be located by palpation of the bracketing elements or with the aid of a surgical incision at least partially exposing at least one of the bracketing elements.

An additional aspect to the invention is directed to a method for
5 maintaining percutaneous access to an excisional site comprising positioning first and second locational elements within a patient at a target site, the locational elements carried by elongate elements extending from the locational elements along a tissue tract and out through an access site in the patient's skin. The first elongate element and first locational element therewith are then removed from the patient and the target site is accessed using
10 the second elongate element and second locational element therewith. The second or both the first and second locational elements may be radially expandable locational elements. This aspect of the invention provides the surgeon the ability to accurately locate the target site. It also permits one of the locational elements to be removed and one to be left at the target site.

15 A still additional aspect of the invention is directed to a percutaneous access assembly including first and second separately movable locational devices, each device including a shaft and a radially expandable element mounted to the shaft. The radially expandable elements are locatable adjacent to one another.

Other features and advantages of the invention will appear from the
20 following description in which the preferred embodiments and methods have been set forth in detail in conjunction with the accompanying drawings.

BRIEF DESCRIPTION OF THE DRAWINGS

Figs. 1A-1C illustrate the use of a tissue removal assembly made
25 according to the invention;

Fig. 2 shows the use of a sleeve which helps prevent seeding of a tissue tract and provides access to a void within the patient;

Figs. 3A-3H illustrate a further aspect of the invention by which
percutaneous removal of target tissue from a target site within the patient is accomplished
30 using a radially expandable/collapsible tubular shaft;

Figs. 4A-4D show a method for percutaneously removing an entire tissue mass from a target site;

Figs. 5A-5D illustrate a target tissue removing device including a pair of tissue engaging devices which bracket the target tissue; and

Figs. 6A-6C show the use of a pair of locational elements, one of which is left in place after target tissue is removed to provide guidance for re-access to the target site.

5

DESCRIPTION OF THE SPECIFIC EMBODIMENTS

Figs. 1A-1C illustrate the use of a tissue removal assembly 2.

Tissue removal assembly 2 includes a support shaft 4 passing through an introducer sheath 5 extending from a handle 6. The distal portion 8 of shaft 4 has a pair of tissue separation wires 10 mounted thereto. Wires 10 are movable from a retracted state of Fig. 1A to a fully extended state of Fig. 1C by moving a slide 12 mounted to handle 6 as indicated in Figs. 1A-1C. Wires 10 are typically made of tungsten or stainless steel and may have a round, rectangular or other cross-sectional shape depending upon the type of tissue and other matter expected to be encountered. U.S. Patent Application 09/248,008 and Provisional Applications 60/_____ (filed September 17, 1999 and entitled
10 Oncological Apparatus and Method for Use) and 60/200,546 describe various tissue separation elements. Wires 10 are coupled to an energy source 14 to supply wires 10 with appropriate energy to aid the cutting or other separating actions of the wires, including electrical, RF, vibrational, electromagnetic, etc. Together, handle 6 and energy source 14 constitute a wire tissue separation element driver 16 because both act to help
15 move wires 10 through tissue 18 beneath a skin surface 20 of the patient.

Appropriate sensors 22 are mounted to one or more of wires 10 and shaft 4. Sensors 22 may include strain gauge sensors, pressure sensors, temperature sensors, etc. Sensors 22 are coupled to a feedback device 24 through sheath 5; feedback device 24 is connected to energy source 14 to ensure that energy source 14 provides an appropriate
20 level of energy to wires 10.

Assembly 2 is used to percutaneously access a target site 26 through an access site 28 in skin surface 20 while in the retracted state. The tip 30 of shaft 4 is positioned distally of the target tissue mass 32. In some situations it may be desirable to pass tip 30 directly through target tissue mass 32 while in other situations it may be
30 desirable to have shaft 4 pass to one side of target tissue mass 32. Once properly positioned, which is preferably accomplished with the aid of remote visualization techniques, such as x-rays, ultrasound, etc., slide 12 is moved in a distal direction causing wires 10 to arc outwardly from the retracted state of Fig. 1A, through the intermediate extended state of Fig. 1B and to the fully extended state of Fig. 1C. Wires 10 are

preferably energized, typically by heating using resistance or RF heating techniques, as wires 10 pass through tissue 18. This is very important when wires 10 pass through target tissue mass 32 and the target tissue mass contains, or possibly contains, cancerous or other diseased tissue. By appropriately energizing wires 10, the tissue wires 10 pass through is, for example, cauterized so that no viable diseased tissue is pulled along with the radially outwardly expanding wires; this helps to keep the healthy tissue surrounding target tissue mass 32 free from viable diseased tissue. In addition to heating the tissue, tissue removal assembly 2 may be provided with vibrational, reciprocating or other mechanical energy to help passage of wires 10 through tissue 18.

10 Once fully expanded, tissue removal assembly 2 is rotated, typically by the user manually grasping and rotating handle 6. If the desired, a motorized or other non-manual rotation of assembly 2 could be provided for. Sensors 22 provide appropriate information to feedback device 24 so to ensure a proper amount of energy is supplied to wires 10 to, among other things, ensure proper cauterization of the tissue as wires 10 are moved readily outwardly while not overly damaging the tissue. Once in the fully extended state of Fig. 1C, the amount of energy supplied to wires 10 may not need to be as great as when, for example, wires 10 pass through only healthy tissue.

 In the embodiment of Figs. 1A-1C two wires 10 are used. This causes target tissue mass 32 to be cut away from the surrounding tissue in two contiguous tissue masses. If desired, only a single wire 10 or more than two wires 10 could be used. Using the method described with respect to Figs. 1A-1C, the entire target tissue mass 32 may be removed in a simultaneous manner. This aspect of the invention will be described in more detail below with reference to Figs. 4A-4D. All or part of the procedure, such as expanding, cutting, rotating, energizing, etc., could be automated.

25 Additional aspects of the invention will be described below with reference to additional figures, with like structure referred to with like reference numerals.

 Fig. 2 illustrates two additional aspects of the invention. A sleeve 36 is used to help prevent seeding of a tissue tract 38 extending between access site 28 and target site 26. Protective sleeve 36 is positioned along tissue tract 38 and has a distal opening 40, preferably positioned adjacent to or within target site 26, and an open interior 42. Target tissue 44 is moved from target site 26 through opening 40 and into open interior 42. Fig. 2 illustrates this having been accomplished using a tissue engagement device 45 having a radially expandable mesh device 46 at the distal end of a shaft 48. Mesh device 46 is of a type which can be movable from a generally cylindrical

orientation, not shown, to the radially extended configuration shown in Fig. 2 by pushing the distal ends of the cylindrical mesh material towards one another. Examples of this type of mesh structure can be found in U.S. Patent Application No. 09/376,678 filed August 18, 1999, entitled Target Tissue Localization Device and Method and in
5 Provisional Application 60/200,546. Other methods and devices for moving target tissue 44 from target site 26 into interior 42 can also be used. Target tissue 44 can then be removed from the patient by either leaving protective sleeve 36 in place and sliding the target tissue out through the opened proximal end 50 of sleeve 36 or by removing the entire structure, that is protective sleeve 36, mesh device 46, shaft 48 and target tissue 44
10 therewith, from tissue track 38 of the patient.

A further aspect of the invention can also be discussed with reference to Fig. 2. In this aspect of the invention, access to a void 52 within a patient can be maintained by placing sleeve 36 along tissue tract 38 and leaving it in place. This method may be accomplished after removal of, for example, a biopsy specimen or an entire
15 suspect tissue mass. This provides convenient and accurate re-access to void 52. Such re-access may be used, for example, when additional tissue samples are needed, therapeutic drugs need to be delivered to void 52, a prosthesis is to be implanted into void 52, or for other reasons.

Figs. 3A-3H illustrate another aspect of the invention by which
20 percutaneous removal of target tissue 44 from target site 26 is accomplished. A hollow, radially expandable/collapsible tubular shaft 54 is passed along tissue tract 38 when in a radially collapsed condition as shown in Fig. 3A. Fig. 3B illustrates the introduction of a tubular enlarger 56 including a conical tip 58 mounted to the distal end of a shaft 60 and a stabilizing sleeve 62 extending proximally from conical tip 58. As illustrated in Figs. 3B
25 and 3C, pushing enlarger 56 through shaft 54 causes the shaft to radially enlarge along its length; stabilizing sleeve 62 resists the tendency of shaft 54 to radially collapse. Once sleeve 62 is properly positioned within shaft 54, shaft 60 and tip 58 therewith are removed from within sleeve 62 as shown in Fig. 3D. Also, Fig. 3D illustrates the positioning of a tissue engagement device 45 to help draw a sample of target tissue 44
30 into the interior 64 of sleeve 62 as suggested in Figs. 3D and 3E.

At this point a sample of the target tissue 44 may be removed from the patient by simultaneously removing shaft 54 in its enlarge diameter form, sleeve 62 and device 45 as a unit. Alternatively, stabilizing sleeve 62 may be removed as device 45 pulls tissue 44 into shaft 54 while shaft 54 remains in place. This suggested in Figs. 3E

and 3F and permits shaft 54 to return towards its initial, radially contracted condition thus causing the tissue sample housed therein to be radially compressed. The collected target tissue 44 remains within shaft 54 when sleeve 62 is removed from shaft 54 and mesh device 46 is collapsed (see Fig. 3F). Shaft 54 then naturally assumes a smaller diameter condition as shown in Figs. 3F and 3G which permits shaft 54 and the target tissue therein to be removed through access site 28 as shown in Figs. 3G and 3H. In this way the size of access site 28 may be smaller than the original size of target tissue 44. Device 45 may remain within shaft 54 during this removal from the patient, or device 45 may, as suggested in Figs. 3G and 3H, be removed from shaft 54 along with sleeve 62.

10 The entire shaft 54 was enlarged in the embodiment of Figs. 3A-3H. If desired, only the part of shaft 54 within the patient may need to be expanded. This would reduce the maximum size which access site 28 is forced to assume, even if only temporarily. The following U.S. Patents show radially-expanding dilators: 5,183,464; 5,431,676; 5,454,790.

15 Figs. 4A-4D illustrate a method for percutaneously removing an entire tissue mass containing target tissue 44. A tissue removal assembly 66 includes a sheath 68 extending from a proximal end adapter 70 and passes through an access site 28 and along tissue tract 38. Sheath 68 houses a tissue engagement device 45, shown in Fig. 4A, after having passed by or through target tissue 44 and manipulated to cause mesh device 20 46 to assume a radially expanded condition. Next, a tubular mesh device 72 is used to surround target tissue 44. Device 72 is of the type in which a tubular mesh material having an open distal end expands radially outwardly as it is compressed axially. That is, the resistance to the axial movement mesh device 72 causes it to contract axially and expand radially to assume the generally funnel-shaped configuration of Fig. 4B. As shown in Fig. 4B, mesh device 46 acts as a blocking element and mesh device 72 acts as a removing element. Together devices 46, 72 at least substantially surround, and preferably fully surround or envelope, target tissue 44.

25 The entire suspect tissue mass, that is the mass including target tissue 44 and an amount of surrounding tissue, can be removed through access site 28. To help prevent trauma to access site 28 during such removal, mesh device 46 and tubular mesh device 72 are caused to contract radially, thus compressing target tissue 44 into a smaller diameter mass for ease of removal from the patient. This is suggested in Figs. 4C and 4D. The construction and use of structure similar to device 72 is described in Patent Application No. 09/248,008 and Provisional Application No. 60/200,546. Note that the

structure shown in Figs. 1A -1C could be used to sever target tissue 44 so that the entire suspect tissue mass, that is including target tissue 44, may be simultaneously removed as two contiguous pieces from the patient along the tissue tract. It is expected that the entire suspect tissue mass could be severed into at most four contiguous pieces and still be simultaneously removed in a useful condition for further testing and/or evaluation. One such structure could use the cutting device of Figs. 1A -1C plus a mesh material similar to tubular mesh device 72 which could be guided by expanded wires 10 to surround the suspect tissue mass. As seen by comparing Figs. 4B and 4C, the largest lateral dimension of the access opening 28 is smaller than the largest lateral dimension of a suspect tissue mass prior to removal; radially or laterally squeezing the suspect tissue mass permits removal of the tissue mass with minimal trauma to the patient. The suspect tissue mass may be monitored for disease prior to, during and/or after removal from the patient.

Figs. 5A-5D illustrate a target material removing device 78 including a sheath 80 within which a pair of tissue engaging devices 45 slidable pass. Fig. 5A illustrates device 78 passing through access site 28, along tissue tract 38 and to target tissue 44 at target site 26. The first and second mesh devices 46A, 46B are placed at distal and proximal locations relative to target tissue 44. Once in position, mesh devices 46 are expanded as shown in Figs 5B and 5C so to bracket target tissue 44. Mesh devices 46A, 46B in their expanded conditions are sized so to define a bracketed region 82 therebetween. Bracketed region 82 is preferably sized to completely contain the tissue mass including target tissue 44. When so bracketed, the health professional can locate target tissue 44 by virtue of the expanded mesh devices 46. In one embodiment mesh devices 46A, 46B are harder than the surrounding tissue so that target tissue 44 within bracketed region 82 may be found by palpation. In addition, expanded meshed devices 46A, 46B guide a surgeon in locating and excising the entire target mass using surgical techniques. The using of bracketing guides 46A, 46B is important because target tissue 44 is often difficult to differentiate from surrounding tissue both in appearance and in feel. After the surgeon has accessed target tissue 44, guided by bracketing mesh devices 46, the entire suspect tissue mass 84 can be removed as a single mass as suggested in Fig. 5D. It is expected that the device of Figs. 5A-5D may be useful in both percutaneous and open incisional situations.

Fig. 6A-6C show the use of essentially the same type of structure as in Figs. 5A-5D but for a different purpose. In this case devices 45 are used as locational elements. In the preferred embodiment both of the locational elements have radially

expandable elements, such as mesh devices 46, both of which are positioned distally of target tissue 44. After removal of target tissue 44, which may occur along with proximal device 45B, device 45A remains in place adjacent to the excisional site or void 52 created by the removal of target tissue 44. This may be used to help maintain void 52 open to aid
5 re-access to the site. Maintaining void 52 open also permits insertion of a space-saving device or structure into void 52. Instead of using two radially expandable elements as portions of the locational devices, locational device 45A could be simply, for example, a catheter shaft in which with the distal end would remain at the distal end of excisional site 52.

10 Modification and variation can be made to the disclosed embodiments without departing from the subject of the invention as defined in the following claims. For example, collapsing mesh device 46 could be replaced by, for example, an expandable balloon or an expandable malecot.

15 Any and all patents, patents applications and printed publications referred to above are hereby incorporated by reference.

WHAT IS CLAIMED IS:

- 1 1. A tissue removal method comprising:
2 positioning a tissue separation device at a target site within a patient, the
3 tissue separation device comprising a selectively energized tissue separation element;
4 separating a tissue sample by the movement of the tissue separation
5 element through the tissue at the target site;
6 monitoring a factor relating to the restriction to the passage of the tissue
7 separation element through the tissue during the separating step; and
8 adjusting, as needed, energy supplied to the tissue separation element
9 based on the results of the monitoring step.
- 1 2. The method according to claim 1 wherein the positioning step is
2 carried out percutaneously.
- 1 3. The method according to claim 1 wherein the separating step is
2 carried out by radially expanding a wire-type tissue separation element from a support
3 shaft and then rotating the support shaft about the support shaft axis.
- 1 4. The method according to claim 1 wherein the monitoring step
2 monitors at least one of the following factors: strain, pressure, temperature, force,
3 resistance.
- 1 5. The method according to claim 1 wherein the adjusting step adjusts
2 at least one of the following types of energy: electrical, RF, mechanical, electromagnetic.
- 1 6. The method according to claim 1 wherein the monitoring step
2 comprises manually monitoring said factor using tactile feedback to the user.
- 1 7. A tissue removal assembly comprising:
2 an elongate tissue separation device comprising a tissue separation element
3 mounted to a support;
4 the tissue separation element movable from a retracted state to an extended
5 state;
6 a tissue separation element driver operably coupled to the tissue separation
7 element to permit the tissue separation element separate a target tissue mass from a

8 patient, the tissue separation element driver comprising an energy source coupled to the
9 tissue separation device;

10 a sensor, operably coupled to at least one of the tissue separation device
11 and the tissue separation element driver, which senses resistance to the separation of the
12 target tissue mass from the patient, and

13 a feedback device operably coupling the sensor and the tissue separation
14 element driver so that the amount of energy supplied by the tissue separation element
15 driver to the tissue separation element can be adjusted based on the restriction to the
16 passage of the tissue separation element through the patient's tissue.

1 8. The assembly according to claim 7 wherein the tissue separation
2 element comprises a wire and the energy source comprises at least one of the following
3 energy sources supplying energy to the wire: electrical, RF, vibrational.

1 9. The assembly according to claim 7 wherein the tissue separation
2 driver further comprises a user-graspable handle at a proximal end of the support.

1 10. The assembly according to claim 7 wherein the support comprises
2 an elongate support shaft having proximal and distal ends, the tissue separation element
3 mounted to said distal end.

1 11. A method for helping to prevent seeding of a tissue tract with cells
2 from the vicinity of a target site, the tissue tract extending between an access site in a
3 patient's skin and the target site, comprising:

4 positioning a protective device along the tissue tract, the device having an
5 opening and an open inner region;

6 moving tissue from the target site, through the opening in the device and
7 into the inner region; and

8 moving the tissue along the tissue tract and out of the patient while
9 keeping the tissue within the device.

1 12. The method according to claim 11 wherein the positioning step is
2 carried out using an open-ended tubular protective device.

1 13. The method according to claim 11 further comprising maintaining
2 the protective device substantially in place axially along the tissue path during the second
3 moving step.

1 14. The method according to claim 11 wherein the positioning step is
2 carried out with the opening adjacent to the target site.

1 15. A tissue tract device comprising:
2 a tubular body sized to extend along a tissue tract between an access site in
3 a patient's skin and a site within the patient; and
4 the body comprising a radially-enlarged proximal end, configured to lie
5 against the skin surface of the patient, and a distal end.

1 16. The device according to claim 15 further comprising a tissue
2 retrieval device positionable within tubular body and having a distal part extendable
3 through the distal end.

1 17. A method for the percutaneous removal of tissue from a target site
2 within a patient comprising:
3 passing a hollow, radially expandable/collapsible portion of an elongate
4 member along a tissue tract, extending from an access site in a patient's skin to a target
5 site in the patient, with the portion in a radially collapsed condition;
6 positioning the portion at a chosen position relative to the target site;
7 radially expanding at least a part of the portion;
8 taking a tissue sample from the target site and housing said tissue sample
9 within the portion;
10 removing the tissue sample from the patient while maintaining the tissue
11 sample within the elongate member;
12 at least partially collapsing the part of the portion; and
13 removing the at least partially collapsed portion from the patient.

1 18. The method according to claim 17 wherein the passing step is
2 carried out using a collapsible tube.

1 19. The method according to claim 17 wherein the tissue sample
2 removing step takes place simultaneously with the portion removing step.

1 20. The method according to claim 17 wherein the tissue sample
2 removing step takes place prior to the portion removing step.

1 21. The method according to claim 17 wherein the collapsing step:
2 takes place with the tissue sample housed within the portion; and
3 acts to radially compress the tissue sample prior to the removing step.

1 22. A percutaneous tissue sample removal assembly comprising:
2 an elongate member, at least a distal portion thereof being a radially
3 expandable/collapsible, said distal portion having an open interior and an open distal end;
4 a distal portion expanding/collapsing device; and
5 a tissue sample retrieval device operable to position a tissue sample
6 through the open distal end and into the open interior.

1 23. The assembly according to claim 22 wherein the entire elongate
2 member is radially expandable/collapsible.

1 24. A method for percutaneously removing an entire tissue mass
2 comprising:
3 forming an access opening in the patient's skin;
4 percutaneously accessing a target site, containing a suspect tissue mass, of
5 a patient along a tissue tract connecting the target site and the access opening in the
6 patient's skin;
7 simultaneously removing the entire suspect tissue mass from the patient
8 along the tissue tract; and
9 the forming and simultaneously removing steps carried out so the largest
10 lateral dimension of the access opening is smaller than the largest lateral dimension of the
11 suspect tissue mass prior to removal.

1 25. The method according to claim 24 further comprising severing the
2 entire suspect tissue mass from adjacent tissue in at most four contiguous pieces.

1 26. The method according to claim 24 further comprising checking
2 margins of the suspect tissue mass for disease.

1 27. The method according to claim 24 further comprising monitoring
2 the suspect tissue mass for disease at one or more of the following: prior to, during or
3 after the removing step.

1 28. The method according to claim 27 wherein the monitoring step is
2 carried out following the simultaneous removing step.

1 29. A percutaneous tissue mass retrieval assembly comprising:
2 a shaft having a distal end;
3 a radially expandable blocking element at the distal end of the shaft;
4 a suspect tissue mass enveloping device;
5 said tissue mass enveloping device movable from an enlarged, tissue mass-
6 surrounding state to a contracted, tissue mass-constricting state so to enable said tissue
7 mass to be removed from a target site with a reduced lateral size.

1 30. The assembly according to claim 29 further comprising:
2 an introducer sheath, said shaft being movable within the sheath and the
3 enveloping device extendable from the introducer sheath towards the blocking element.

1 31. The assembly according to claim 29 wherein the enveloping device
2 comprises an open-ended, axially compressible/radially expandable tubular bracket.

1 32. A method for maintaining access to a void within a patient,
2 comprising:
3 placing an access sleeve along a tissue tract connecting an access site in
4 the patient's skin and a void, whereby access to the void is maintained.

1 33. The method according to claim 32 wherein the placing step takes
2 place following removal of a biopsy specimen, said removal creating the void.

1 34. The method according to claim 32 wherein the placing step takes
2 place following removal of an entire suspect tissue mass, said removal creating the void.

1 35. A method for removing target material from a target site within a
2 patient, comprising:
3 percutaneously placing an expandable blocking element at a first position
4 distal of the target material;
5 expanding the expandable blocking element;
6 percutaneously placing a removing element at a second position;
7 at least substantially surrounding the target material with the blocking
8 element and the removing element; and
9 removing the blocking element, the removing element and the target
10 material therewith from the patient along a tissue tract, the tissue tract connecting the
11 target site and an access site in the patient's skin.

1 36. The method according to claim 35 wherein the first percutaneously
2 placing step is carried out using a radially expandable, tubular mesh material as the
3 expandable blocking element.

1 37. The method according to claim 35 wherein the second
2 percutaneously placing step is carried out using a tubular mesh element having a radially
3 expandable, open distal end.

1 38. The method according to claim 35 wherein the target material is
2 radially surrounded by the removing element during the surrounding step.

1 39. The method according to claim 35 further comprising at least
2 partially radially collapsing the removing element prior to the removing step.

1 40. The method according to claim 39 further comprising at least partly
2 radially collapsing the blocking element prior to the removing step.

1 41. A device for removing target material from a patient comprising:
2 a shaft having a proximal portion, a distal portion and an axis; and
3 first and second axially spaced-apart, radially expandable elements carried
4 by the distal portion of the shaft, the expandable elements being remotely selectively
5 movable between radially retracted and radially expanded states;

6 whereby said radially expandable elements can be used to bracket target
7 material so the target material can be removed from a patient along with the device.

1 42. The device according to claim 41 wherein the radially expandable
2 elements are sufficiently hard so to be detectable by palpation.

1 43. The device according to claim 41 wherein the radially expandable
2 elements are generally disk-shaped when in the radially expanded state.

1 44. The device according to claim 41 wherein the shaft comprises first
2 and second shafts passing through a sheath.

1 45. The device according to claim 41 configured for percutaneous use.

1 46. A method for locating a target mass within a patient comprising:
2 extending the distal end of a shaft to a position distal of a target mass;
3 positioning first and second radially expanding bracketing elements at
4 positions distal of and proximal of the target mass;
5 moving the bracketing elements from radially retracted states to radially
6 expanded states thereby bracketing the target mass; and
7 locating the target mass using the bracketing elements.

1 47. The method according to claim 46 wherein the moving step is
2 carried out so the bracketing elements define a bracketed region therebetween sized to
3 completely contain the target mass.

1 48. The method according to claim 46 wherein the locating step is
2 carried out by palpation of the bracketing elements.

1 49. The method according to claim 46 wherein the locating step is
2 carried out with the aid of a surgical incision at least partially exposing at least one of the
3 bracketing elements.

1 50. The method according to claim 46 carried out percutaneously.

1 51. A method for maintaining percutaneous access to an excisional site
2 comprising:

3 positioning first and second locational elements within a patient at a target
4 site, the first and second locational elements carried by first and second elongate
5 elements, the first and second elongate elements extending from the locational elements
6 at the target site, along a tissue tract and out through an access site in the patient's skin;
7 removing the first elongate element and first locational element therewith
8 from the patient; and
9 accessing the target site using the second elongate element and second
10 locational element therewith.

1 52. The method according to claim 51 wherein the positioning step is
2 carried out with a radially expandable second locational element.

1 53. The method according to claim 52 further comprising radially
2 expanding the second locational element from a collapsed condition to an expanded
3 condition before the accessing step.

1 54. The method according to claim 53 wherein the expanding step is
2 carried out before the removing step.

1 55. The method according to claim 53 wherein the positioning step is
2 carried out with radially expandable first and second location elements, and further
3 comprising expanding the first location element from a collapsed condition to an
4 expanded condition and then contracting the first location element from the expanded
5 condition to a second collapsed condition.

1 56. The method according to claim 53 wherein the radial expansion of
2 second element acts to maintain an open space a the target site.

1 57. A percutaneous access assembly comprising:
2 first and second separately movable locational devices, each said device
3 comprising a shaft and a radially expandable element mounted to the shaft; and
4 said radially expandable elements locatable adjacent one another.

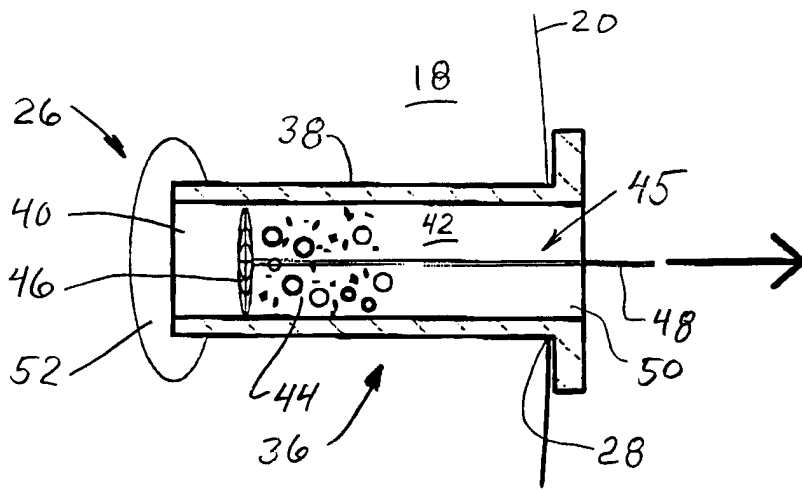

FIG. 2

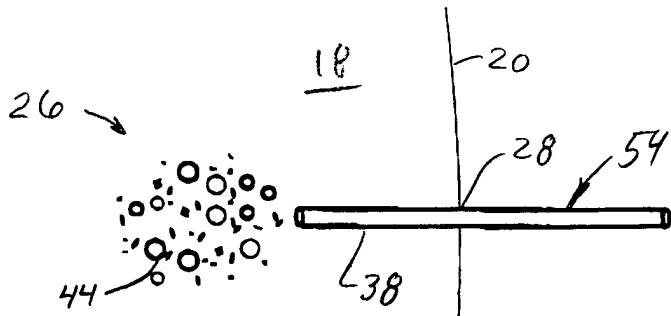

FIG. 3A

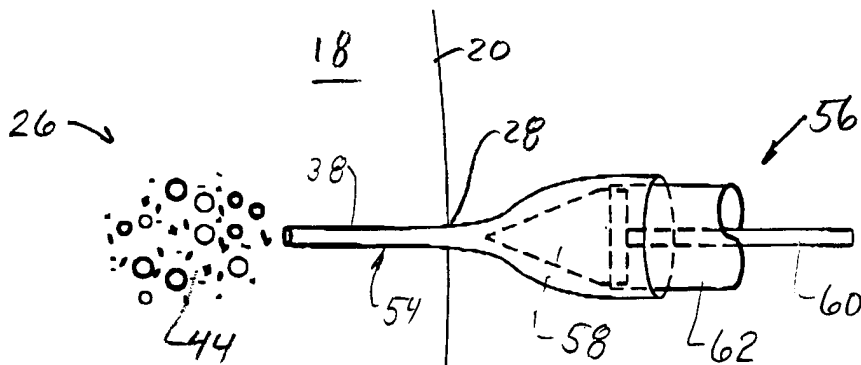

FIG. 3B

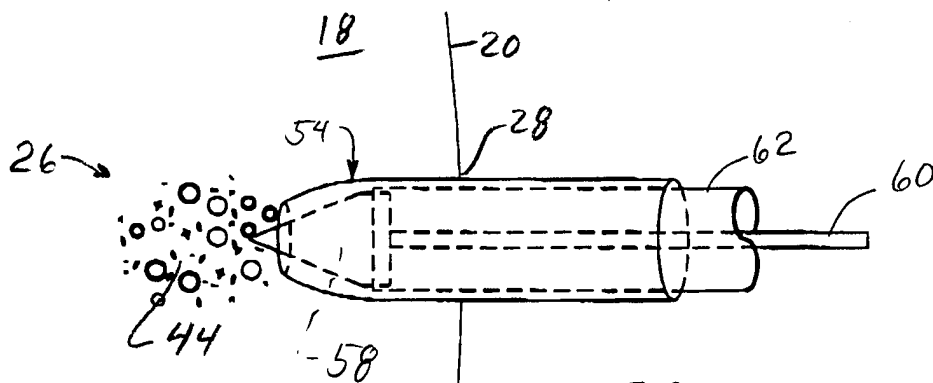

FIG. 3C

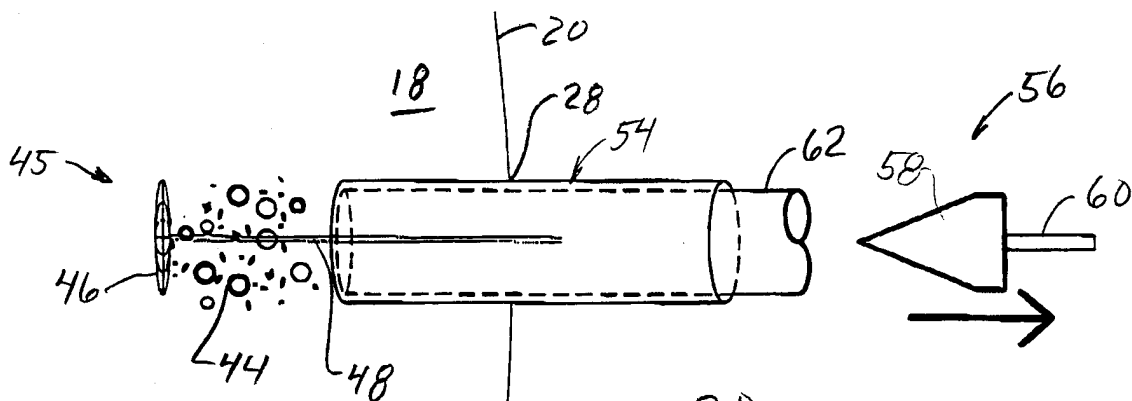
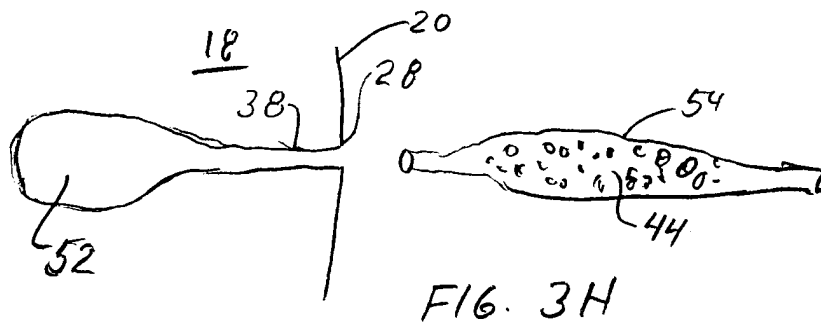
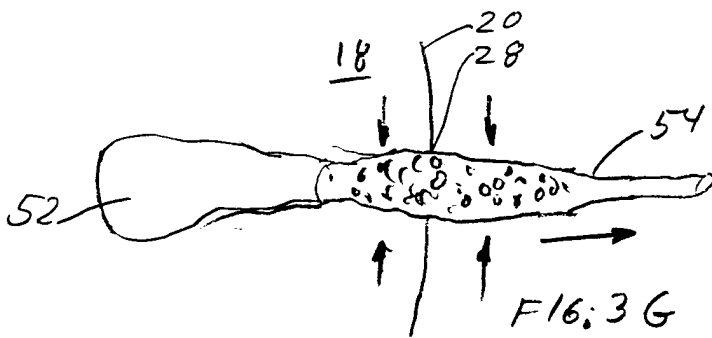
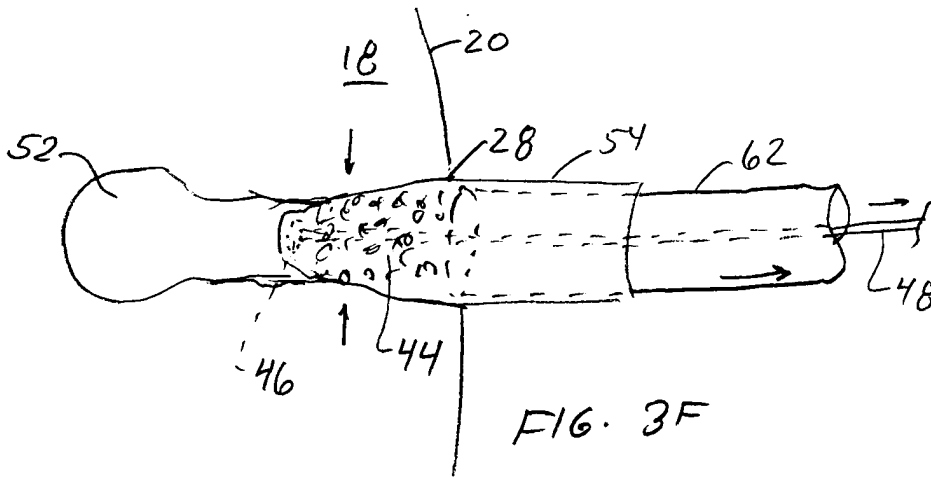
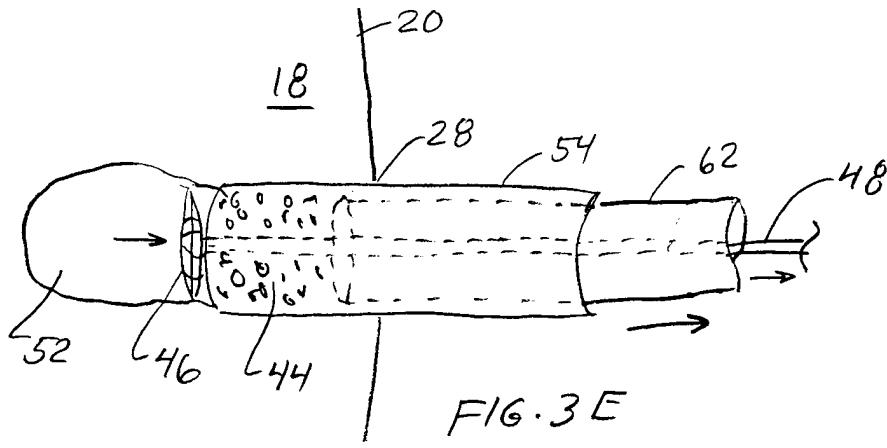
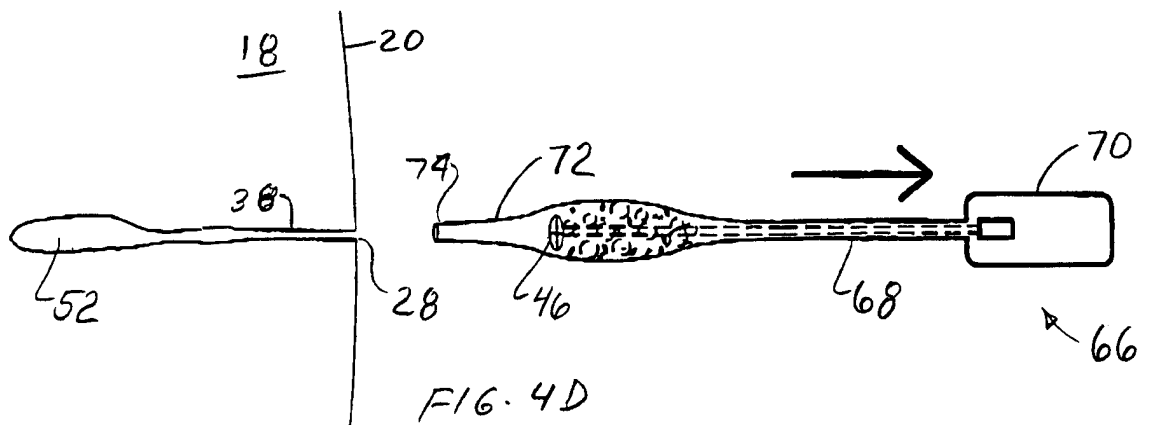
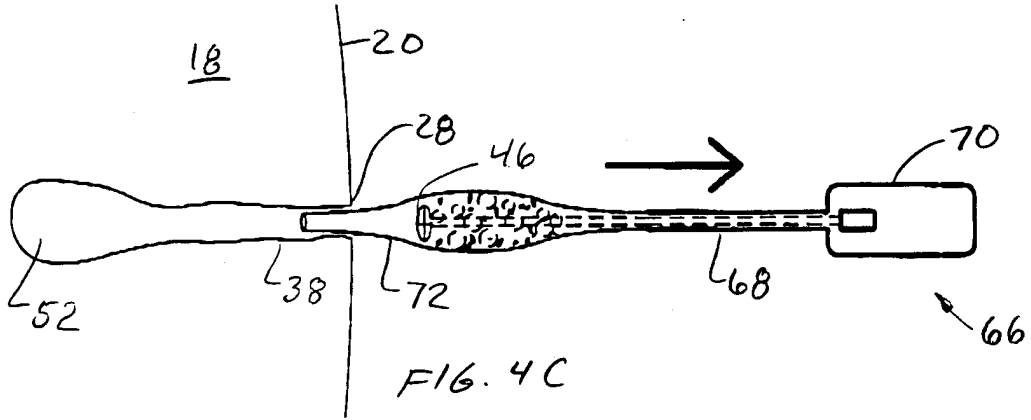
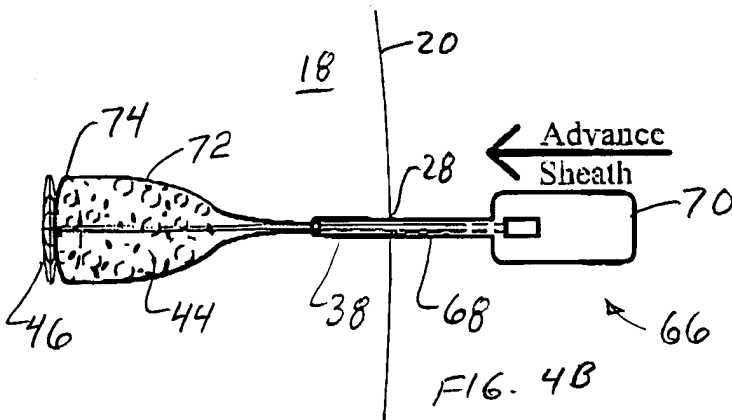
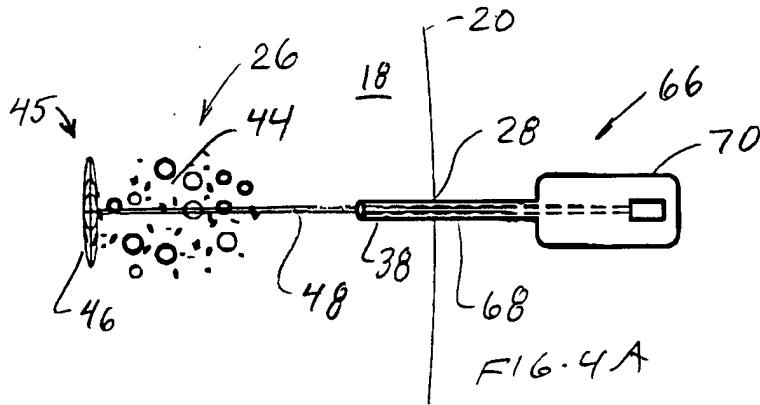
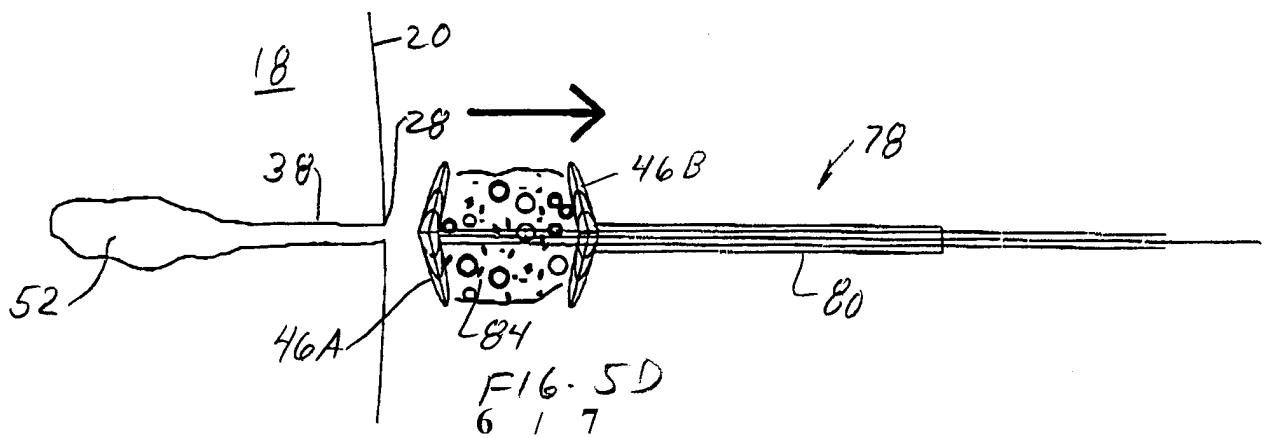
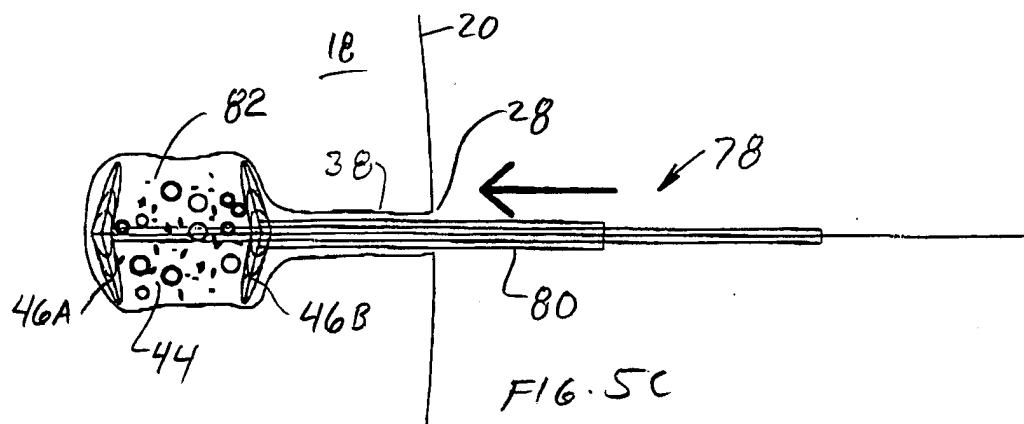
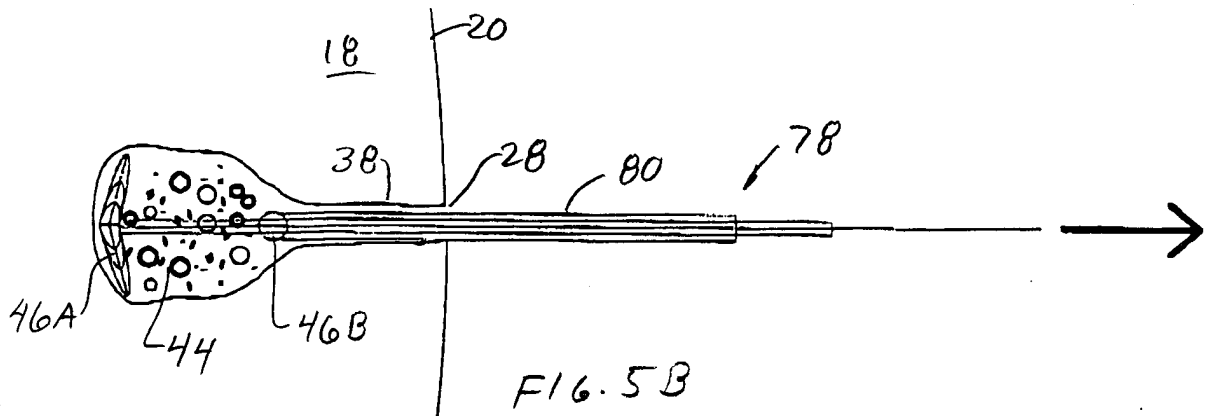
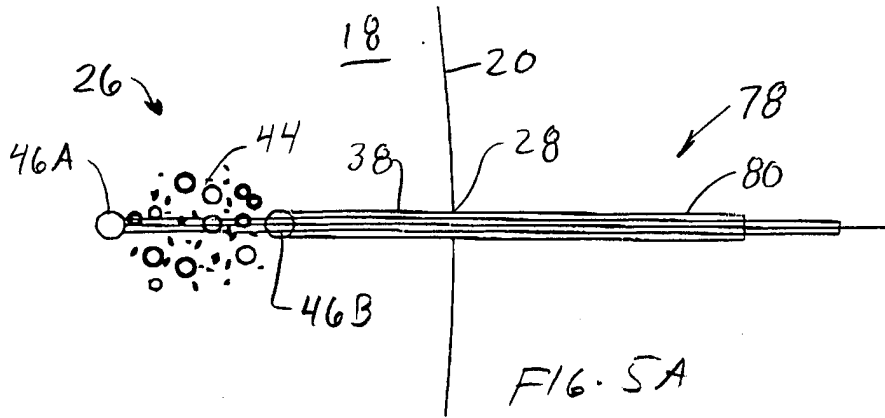
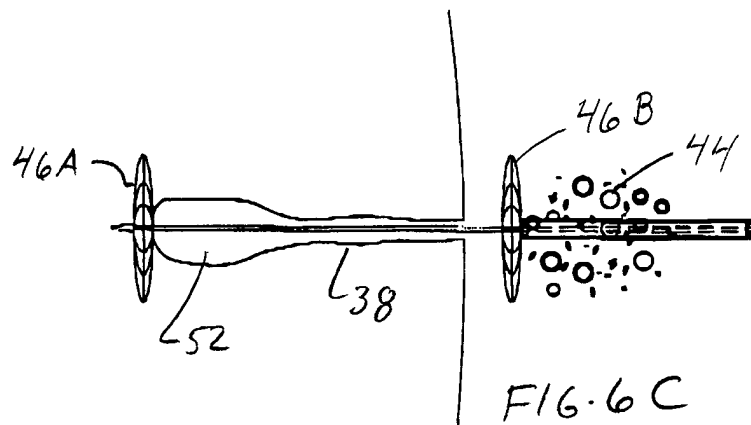
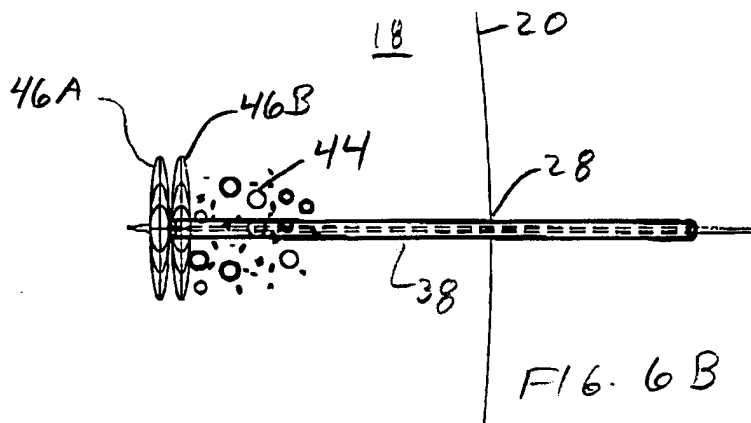
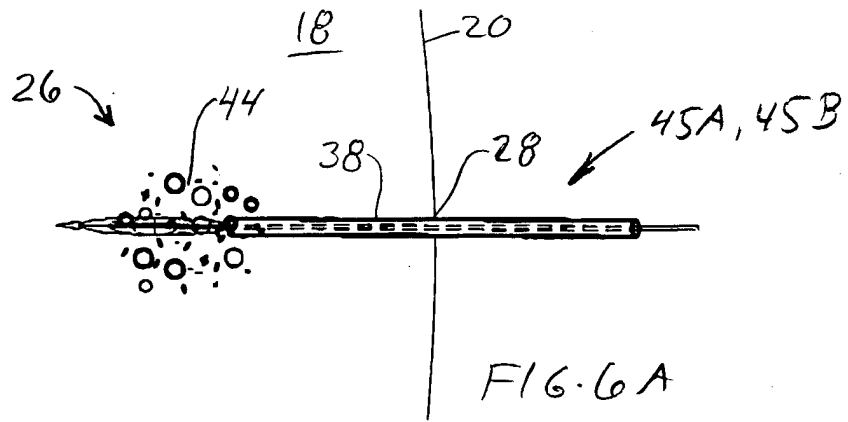

FIG. 3D









INTERNATIONAL SEARCH REPORT

International application No.
PCT/US00/15495

A. CLASSIFICATION OF SUBJECT MATTER
 IPC(7) : A61B 5/00
 US CL : 600/564
 According to International Patent Classification (IPC) or to both national classification and IPC

B. FIELDS SEARCHED
 Minimum documentation searched (classification system followed by classification symbols)
 U.S. : 600/564-567

Documentation searched other than minimum documentation to the extent that such documents are included in the fields searched
 NONE

Electronic data base consulted during the international search (name of data base and, where practicable, search terms used)
 WEST

C. DOCUMENTS CONSIDERED TO BE RELEVANT

Category*	Citation of document, with indication, where appropriate, of the relevant passages	Relevant to claim No.
Y	US 5,100,423 A (FEARNOT) 31 March 1992, Figs. 1-9.	1-10
Y	US 5,735,289 A (PFEFFER et al.) 07 April 1998, Figs. 1-8.	11-57
A	US 5,183,464 A (DUBRUL et al.) 02 February 1993.	1-57
A	US 5,431,676 A (DUBRUL et al.) 11 July 1995.	1-57
A	US 5,454,790 A (DUBRUL) 03 October 1995.	1-57

Further documents are listed in the continuation of Box C. See patent family annex.

* Special categories of cited documents: "A" document defining the general state of the art which is not considered to be of particular relevance "E" earlier document published on or after the international filing date "L" document which may throw doubts on priority claim(s) or which is cited to establish the publication date of another citation or other special reason (as specified) "O" document referring to an oral disclosure, use, exhibition or other means "P" document published prior to the international filing date but later than the priority date claimed	"T" later document published after the international filing date or priority date and not in conflict with the application but cited to understand the principle or theory underlying the invention "X" document of particular relevance; the claimed invention cannot be considered novel or cannot be considered to involve an inventive step when the document is taken alone "Y" document of particular relevance; the claimed invention cannot be considered to involve an inventive step when the document is combined with one or more other such documents, such combination being obvious to a person skilled in the art "&" document member of the same patent family
---	--

Date of the actual completion of the international search 21 AUGUST 2000	Date of mailing of the international search report 03 OCT 2000
---	--

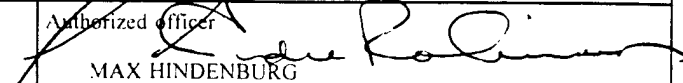
Name and mailing address of the ISA/US Commissioner of Patents and Trademarks Box PCT Washington, D.C. 20231 Facsimile No. (703) 305-3230	Authorized officer  MAX HINDENBURG Telephone No. (703) 308-3130
---	--

专利名称(译)	组织去除方法和装置		
公开(公告)号	EP1191876A1	公开(公告)日	2002-04-03
申请号	EP2000942681	申请日	2000-06-05
[标]申请(专利权)人(译)	ARTEMIS医疗		
申请(专利权)人(译)	ARTEMIS MEDICAL , INC.		
当前申请(专利权)人(译)	ARTEMIS MEDICAL , INC.		
[标]发明人	DUBRUL WILLIAM R FULTON RICHARD E CURTIS ROBERT M		
发明人	DUBRUL, WILLIAM, R. FULTON, RICHARD, E. CURTIS, ROBERT, M.		
IPC分类号	A61B10/02 A61B10/00 A61B18/00 A61B18/04 A61B18/12 A61B18/14 A61B19/00 A61B5/00		
CPC分类号	A61B10/0266 A61B18/14 A61B2090/3904 A61B2090/3908		
代理机构(译)	WORK , 伊利亚		
优先权	60/137775 1999-06-04 US 60/154394 1999-09-17 US 09/336360 1999-06-18 US 60/146892 1999-08-02 US 60/200546 2000-04-27 US		
其他公开文献	EP1191876A4		
外部链接	Espacenet		

摘要(译)

使用各种类型的装置和方法来访问，移除目标组织。一种这样的装置包括支撑轴（2），引导器护套（5），手柄（6），分离线（10），滑动件（12），能量源（14）和反馈装置（24）。