



(11) **EP 2 142 088 B1**

(12) **EUROPEAN PATENT SPECIFICATION**

(45) Date of publication and mention of the grant of the patent:
19.04.2017 Bulletin 2017/16

(51) Int Cl.:
A61B 5/00 (2006.01) **A61B 18/14** (2006.01)
A61B 18/24 (2006.01) **A61B 17/00** (2006.01)
A61M 25/00 (2006.01) **A61B 90/00** (2016.01)

(21) Application number: **08746501.9**

(86) International application number:
PCT/US2008/061092

(22) Date of filing: **22.04.2008**

(87) International publication number:
WO 2008/137303 (13.11.2008 Gazette 2008/46)

(54) **OPTIC-BASED CONTACT SENSING ASSEMBLY AND SYSTEM**

OPTIKBASIERTE KONTAKTERFASSUNGSBAUGRUPPE UND ENTSPRECHENDES SYSTEM
ASSEMBLAGE ET SYSTÈME DE DÉTECTION DE CONTACT À BASE OPTIQUE

(84) Designated Contracting States:
AT BE BG CH CY CZ DE DK EE ES FI FR GB GR HR HU IE IS IT LI LT LU LV MC MT NL NO PL PT RO SE SI SK TR

- **PAUL, Saurav**
Minnetonka, Minnesota 55305 (US)
- **STEHR, Richard E.**
Stillwater, Minnesota 55082 (US)
- **HEIMBECHER, Reed R.**
Hamel, Minnesota 55340 (US)

(30) Priority: **01.05.2007 US 915387 P**
15.11.2007 US 941073

(43) Date of publication of application:
13.01.2010 Bulletin 2010/02

(74) Representative: **Kramer Barske Schmidtchen**
Patentanwälte PartG mbB
European Patent Attorneys
Landsberger Strasse 300
80687 München (DE)

(60) Divisional application:
17159024.3

(73) Proprietor: **St. Jude Medical,**
Atrial Fibrillation Division, Inc.
St. Paul, Minnesota 55117-9913 (US)

(56) References cited:
EP-A1- 0 900 549 **WO-A2-2004/069072**
GB-A- 2 331 580 **US-A- 4 834 101**
US-A1- 2002 123 749 **US-A1- 2007 060 847**

(72) Inventors:
• **TEGG, Troy T.**
Elk River, Minnesota 55330 (US)

EP 2 142 088 B1

Note: Within nine months of the publication of the mention of the grant of the European patent in the European Patent Bulletin, any person may give notice to the European Patent Office of opposition to that patent, in accordance with the Implementing Regulations. Notice of opposition shall not be deemed to have been filed until the opposition fee has been paid. (Art. 99(1) European Patent Convention).

Description

BACKGROUND OF THE INVENTION

a. Field of the Invention

[0001] The instant invention relates to an optic-based sensing assembly. The instant invention includes an optic-based catheter assembly and related system used to monitor or determine contact between a catheter and the surrounding proximate environment, such as tissue. Such a system may be used for visualization, mapping, ablation, and/or other methods of diagnosis and treatment of tissue.

b. Background Art

[0002] The visualization and treatment of organs and tissues has been advanced through the increasing use of catheter systems. Catheter systems have been designed for the incorporation of various components to treat and diagnose ailments, as accomplished through the mapping of organs, sensing of thermal and electrical changes exhibited by a tissue (e.g., heart), as well as the application of energizing sources (such as radiofrequency, cryogenics, laser, and high frequency ultrasound) to tissue.

[0003] Catheter systems generally include a portion that contacts the tissue or organ, or is inserted in an environment (e.g., heart chamber or vessel) to detect a number of parameters, such as for example, location of the tissue, contact or pressure exerted on the tissue, electrophysiological attributes of the tissue, or other type of parameters that aid in the evaluation or treatment of the organ or tissue.

[0004] It is known that sufficient contact between a catheter, in particular an electrode provided in connection with a catheter, and tissue during a procedure is generally necessary to ensure that the procedures are effective and safe. Current techniques of mapping, visualization and treatment using energizing sources, such as the use of radiofrequency energy during ablation, rely on the placing of the electrode of a catheter system in consistent mechanical contact with targeted tissue. Perforations of the cardiac wall as well as lesion formation (such as lesions created by exposure to radiofrequency) partially depends upon the direction of contact between the electrode and tissue. In particular, for endocardial catheter applications, the point of electrode-tissue contact is typically 150 cm away from the point of application of force applied by the operator (whether manual or automated) of the catheter outside of the body. Coupled with the fact that a beating heart is a dynamically moving wall, this gives rise to some functional and theoretical challenges such as ensuring that the electrode is in sufficiently constant mechanical contact with the myocardial wall.

[0005] Catheter systems having sensor assemblies, such as those mounted on the catheter shaft proximal to

the electrode or remotely in the handle set, leave the possibility, however small, of obtaining false positive outcomes when detecting contact between the electrode and the tissue. False positive outcomes may occur, for example, when the catheter wall, and not the electrode, is in contact with the tissue. Such condition may arise during the catheter manipulation in the heart when, for instance, the distal portion of the catheter is curled inward so much as to lose electrode contact with the tissue, while the distal portion of the catheter is in contact with the tissue. When that happens, remotely placed sensors generate signals due to the deflection of the catheter shaft, thereby falsely indicating contact between the electrode and tissue. Accordingly, optic-based contact sensors coupled to the electrode can, among other things, help reduce the possibility of obtaining false positive outcomes when detecting contact between the electrode and the tissue.

[0006] US 2007/0060847 A1 relates to an apparatus for diagnosis or treatment of a vessel or organ, the apparatus comprising a catheter having a distal extremity, at least two optical fiber sensors affixed within the distal extremity, and processing logic operatively coupled to receive an output of the optical fiber sensors, the processing logic programmed to compute a multidimensional force vector corresponding to a contact force between the distal extremity and a tissue wall of the organ or vessel.

[0007] WO 2004/069072 A2 discloses a cardiac ablation instrument comprising a catheter body adapted for disposition over a guidewire to a location within a heart, the catheter body having at least one lumen therein, whereby the catheter body can be slid over the guidewire to a desired location within the heart, a projection balloon adapted for inflation within the heart to provide a transmission pathway for ablative energy to be delivered to a target tissue site, and an energy emitter coupled to the catheter body for projection of ablative energy to the target tissue site.

[0008] GB 2 331 580 A relates to a probe at the distal end of a heart catheter for coagulating muscle tissue and/or connective tissue by means of high frequency energy and a built-in temperature sensor for measuring the heat of the tissue adjacent the coagulation region of the probe, the probe being surrounded by a hermetically tight tube apart from this hermetically sealing region together with the catheter, wherein the probe is simultaneously a sensor for measuring the axial pressure or, respectively, the effect of axial force upon the probe tip and is constructed such that the sensor comprises a hard, tissue-compatible plastics material carrier, in which a photoconductor, which emerges coaxially at the distal end of the catheter, terminates in an axial bore, at the base of the bore or respectively at the end of the plastics material carrier there is inserted a reflector, the reflective surface of which is perpendicularly traversed by the catheter axis and is oriented towards the end face of the photoconductor end, so that the reflected beam of light, emerging at

the end face of the photoconductor and encountering the mirror, is guided back with the beam portion re-encountering this end face to the photoconductor inlet at the proximal end of the heart catheter, the mirror face does not alter its reflective power in the event of differences in temperature vis-à-vis the ambient surroundings or upon contact, between the end face of the photoconductor end and the mirror face is a clearance with non-reflective walls, which clearance is shortened by the effect of axial force on the probe tip in the direction of the catheter end, in dependence on said direction, and hence causes a change in the efficiency of the beam guided back in the photoconductor.

BRIEF SUMMARY OF THE INVENTION

[0009] The invention is defined in claim 1. For some applications, it is desirable to have an optic-based catheter system that includes an optical sensor that detects changes in reflected energy, such as light, from an optically interactive surface provided by an electrode. In an embodiment, the electrode is subjected to a compressive force due to mechanical contact of the electrode surface with another body or surface. The optical sensor of the present invention can be used to measure contact of an electrode with a dynamically moving wall, such as a beating heart.

[0010] Thus, according to the present invention, a contact sensing assembly for sensing contact with a target (e.g., a tissue or other organ surface) is provided as claimed in claim 1. as claimed in claim 15.

[0011] The present invention is further directed to an optic-based catheter system as claimed in claim 15.

[0012] The aspects, features, details, utilities, and advantages of the present invention will be apparent from reading the following description and claims, and from reviewing the accompanying drawings.

BRIEF DESCRIPTION OF THE DRAWINGS

[0013]

Figure 1 is a partial perspective view of a catheter assembly in accordance with an embodiment of the present invention;

Figure 2 is an enlarged partial perspective view of the catheter assembly shown in Figure 1, wherein the electrode and portion of the optic-based sensing assembly is shown in phantom;

Figures 3A and 3B are partial perspective views of portions of an optic-based sensing assembly according to alternative embodiments of the present invention;

Figure 4 is a side elevation view of an alternate embodiment of the present invention;

Figures 5A and 5B are exploded perspective views of an assembly of the type shown in Figure 4;

Figure 6 is a side cross-sectional view of an assem-

bly of the type shown in Figure 4;

Figure 7 is a side cross-sectional view of an assembly in accordance with another embodiment of the present invention;

Figure 8 is a cross-sectional view of an assembly in accordance with another embodiment of the present invention;

Figures 9A-9F are alternate embodiments of a portion of the assembly of the type shown in Figure 5B; Figures 10A-10B are alternate embodiments of a portion of the assembly for incorporation with the present invention; and

Figures 11A-11I are schematic overviews of the system in accordance with alternate embodiments of the present invention.

DETAILED DESCRIPTION OF THE INVENTION

[0014] Referring now to the drawings wherein like reference numerals are used to identify like components in the various views, Figures 1 and 2 illustrate an exemplary embodiment of a contact sensing assembly 10 as provided by the present invention. In a general form, the contact sensing assembly 10 includes a catheter 12, an electrode 14 connected to the catheter, and an optical sensor 16 for optically interacting with a portion of electrode 14. The contact sensing assembly may be used in the diagnosis, visualization, and/or treatment of tissue (such as endocardial tissue) in a body. Contact sensing assembly 10 may be used in a number of diagnostic and therapeutic applications, such as for example, the recording of electrograms in the heart, the performance of cardiac ablation procedures, and/or various other applications. The catheter assembly can be used in connection with a number of applications that involve humans, or other mammals, for tissue observation, treatment, repair or other procedures. Moreover, the present invention is not limited to one particular application, but rather may be employed by those of ordinary skill in the art in any number of diagnostic and therapeutic applications.

[0015] Catheter 12 of the present invention includes a body 18 having a distal end 20 and a proximal end 22. Body 18 of catheter 12 is generally tubular in shape, although other configurations of the catheter may be used as known in the industry. Distal end 20 of catheter 12 is connected to electrode 14, while body 18 of catheter 12 may house optical sensor 16 and may house other components used in the diagnosis and/or treatment of tissue. If desired, the outer portion of catheter 12 may have a braided outer covering therein providing increased flexibility and strength. The catheter of the present invention vary in length and are attached to a handle or other type of control member that allows a surgeon or operator of the catheter to manipulate the relative position of the catheter within the body from a remote location, as recognized by one of ordinary skill in the art.

[0016] As generally shown in Figure 1, an embodiment of the present invention includes distal end 20 of catheter

12 that includes at least a portion or segment that exhibits increased flexibility relative to more proximal portions of the catheter 12. The increased flexibility of at least a portion or segment associated with the distal end 20 may be achieved through any number of methods, including but not limited to, the use of flexible materials, the formation of a spring-like coupling portion, or any other type of connection that allows for increased flexibility at a portion or segment of the distal end 20 of catheter 12.

[0017] Electrode 14 is connected to distal end 20 of catheter 12. Upon the exertion of external contact force on the surface of electrode 14, at least a portion of distal end 20 of catheter 12 flexes and/or bends relative to electrode 14. The relative movement (e.g., displacement either axially, laterally or a combination thereof) of distal end 20 may be proportionate or correlated to the force exerted on electrode 14. Electrode 14 includes a tip portion 24 and a base portion 26. Electrode 14 may be configured to include a means for irrigating. For example, without limitation, the incorporation of at least one irrigation port 28 within electrode 14, therein providing an irrigated electrode tip. An irrigated electrode tip allows for the cooling of electrode 14, for instance, through the transporting of fluid through electrode 14 and around the surface of the tissue. A number of different types of electrodes, irrigated and non-irrigated, may be connected and incorporated for use an electrode 14 according to embodiments of the invention depending on the type of procedures being done. Such irrigated electrodes include, but are not limited to, those disclosed in U.S. Patent Application Nos. 11/434,220 (filed May 16, 2006), 10/595,608 (filed April 28, 2006), 11/646,270 (filed December 28, 2006) 11/647,346 (filed December 29, 2006) and 60/828,955 (filed October 10, 2006).

[0018] Electrode 14 includes an optically interactive surface 30 (see, e.g., FIG. 5B), described further below, that is provided on a portion of the electrode 14 that interacts with the optical sensor 16 of the assembly 10. As shown in Figure 2, electrode 14 may further include an electrode cavity 36, as shown in phantom. Electrode cavity 36 may also be used to provide a number of different components and/or functions in connection with the electrode. In one embodiment, electrode cavity 36 may further provide the optically interactive surface therein enabling optical sensor 16 to interact with the internal surface of electrode 14 provided by electrode cavity 36. In alternate embodiments, electrode cavity 36 may serve as a lumen for transferring of irrigation channels, electrical components, or any other type assembly components that need to be transferred through electrode 14.

[0019] An optically interactive surface 30 is provided in connection with a surface associated with electrode 14, such that the surface positioning, configuration, and orientation of the interactive surface (which has a known position with respect to the electrode) allows sufficient interaction and/or functional communication with the optical sensor 16 such that a change in the communication (e.g., optical signal, light intensity) can provide a means

for determining the contact force and/or orientation of the electrode with the tissue or surrounding area. According to the present invention, the base portion 26 of electrode 14 includes said optically interactive surface 30. The optically interactive surface may be comprised of any material suitable for the intended environment that reflects or refracts light energy. For example, without limitation, the interactive surface may comprise a reflective metal, such as a polished metal. The interactive surface 30 may also comprise prisms or other refractive media which may include a reflective surface. Depending on the design of optically interactive surface 30, the interactive surface 30 may further include a mirrored surface, filters positioned relative to surface 30 and/or other types of refractive media in combination with opaque segments, as discussed in more detail below.

[0020] Optical sensor 16 may be positioned within the distal end 20 of the catheter 12. Optical sensor 16 may include at least one optic fiber that transmits and receives an optical signal, such as light energy. The optical sensor may also be manufactured to transmit and/or receive various types of signals including those associated with electromagnetic radiation, lasers, x-rays, radiofrequency, etc. In an embodiment, optical sensor 16 may use light energy to determine the relative contact (e.g., force, stress, and/or orientation) between electrode 14 and an external surface in operational contact with the electrode - for example, tissues and surrounding environments, including organs, heart chambers, and interior of vessels. In an embodiment, the optical sensor may be adapted to measure one or more parameters, including, for example, intensity, wavelength, phase, spectrum, speed, optical path, interference, transmission, absorption, reflection, refraction, diffraction, polarization, and scattering.

[0021] In an embodiment, one or more force vectors may be used to determine the contact force and/or orientation of the electrode in connection with the surrounding tissue or other external surfaces. In particular, the change of intensity of the optical signal received by optical sensor 16 may be correlated to the contact force exerted on electrode 14 by an external surface. The intensity of the optical signals received by optical sensor 16 is proportional to the structural displacement of distal end 20 of catheter 12. As discussed in more detail below, the displacement of distal end 20 is governed by a factor (k) (such as a spring constant) exhibited by the material comprising a portion of distal end 20. Accordingly, the factor (k) may be equated to the external force (F), either laterally or axially, exerted on electrode 14, divided by the unit displacement (D) (either axially or laterally) of electrode, which may be generally expressed as $k = F/D$. Since the change in intensity to the optical signals is proportional to the displacement of the electrode, the external force exerted on the electrode may be determined.

[0022] In order to determine light or optical intensity, optical sensor 16 includes a receiver 32 and an emitter 34 for receiving and emitting light energy, respectively. Receiver 32 and emitter 34 may be included in a single

fiber optic cable or in two separate fiber optic cables, such as shown in Figure 2. A number of optical sensors 16 may be arranged within distal end 20 of catheter 12 to operatively (e.g., optically) interact with an interactive surface 30 that is provided in connection with electrode 14. Moreover, a number of receivers 32 and emitters 34 may be disposed within distal end 20 of catheter 12 in various configurations and combinations to assess contact and/or orientation readings. Such positioning and combinations can be configured adapted to optimize their operation for an intended application or environment. For example, without limitation, as shown in Figures 3A-3B an equal number of emitters and receivers may be provided. In alternate embodiments, an unequal number of emitters and receivers may be provided in various combinations.

[0023] Referring to Figures 2-3B, various embodiments having alternate configurations of optical sensors 16 are illustrated in connection with catheter 12. Each optical sensor 16 includes a receiver 32 and an emitter 34. In the illustrated embodiments, the optical sensors 16 are provided by a fiber optic cable 38, wherein sensors 16 are connected to peripheral wall 40 surrounding a lumen 42 disposed within body 18 of catheter 12. Lumen 42 is provided to carry various components for use in the catheter or contact assembly or provides a passageway for fluids, such as those needed for an irrigated electrode. Figure 3A further illustrates three optical sensors 16 connected to the peripheral wall 40 in a paired configuration wherein receiver 32 and emitter 34 are provided adjacent to one another. Each optical sensor 16 may be positioned relative to one another circumferentially around peripheral wall 40 of lumen 42. In a particular embodiment, as generally shown in Figure 3A, optical sensors 16 may be provided in the paired configuration, wherein the pairs are separated about peripheral wall 40 of fiber optic cable 38. Each of the pairs may be separated by various degrees, such as 120 degrees, as shown. Figure 3B illustrates an example of an alternate embodiment, wherein a plurality of receivers 32 and emitters 34 are circumferentially disposed within the body of the catheter along the peripheral wall 40 from one another. Receivers 32 and emitters 34 may be provided in various combinations, ratios, and relative positions to one another depending on the design of the sensing assembly 10.

[0024] Figures 4-7 further illustrate an embodiment of a contact sensing assembly 10 of the present invention. The assembly 10 includes catheter 12, electrode 14, and optical sensor 16, wherein distal end 20 of catheter 12 includes a coupling member 50 for receiving a portion of electrode 14 for connection with distal end 20 of catheter 12. The coupling member 50 includes a neck portion 52 and a mounting shaft 54.

[0025] As shown in the combination of Figures 5A and 5B, the neck portion 52 of the coupling member 50 may define a receptacle of receiving portion 58 for receiving a portion of electrode 14 for connection with catheter 12. Base portion 26 of electrode 14 can be received by elec-

trode receptacle or receiving portion 58 for connecting electrode 14 to coupling member 50. Neck portion 52 further includes elastic portion 60, that provides increased flexibility. Elastic portion 60 may include a number of alternate embodiments, such as a spring. Elastic portion 60 of neck portion 52 moves relative to the external force exerted on tip portion 24 of electrode 14. Mounting shaft 54 of coupling member 50 is connected to catheter 12, therein forming a flexible distal end 20. In some embodiments, mounting shaft 54 is more rigid than neck portion 52 of coupling member 50 and provides secure engagement with catheter 12. At least one pull wire (not shown) may be attached to mounting shaft 54 for movement and deflection of the catheter. Mounting shaft 54 further provides at least one recessed groove 62 for receiving and mounting optical sensor 16. The recessed groove 62 may position optical sensor 16 so that the end of the optical sensor 16 is flush with mounting shaft 54. Alternate embodiments may provide for optical sensors that extend into the electrode. Overall, the optical sensors are positioned to interact with optically interactive surface 30 as provided by electrode 14. Figure 5B provides an embodiment, wherein optically interactive surface 30 is provided on or is a part of base portion 26 of electrode 14. Optically interactive surface 30 may, in another embodiment, be provided as a coating or formed surface in connection with electrode 14.

[0026] Figures 9A-9F generally illustrate alternate configurations of base portion 26 in accordance with alternate embodiments of the present invention. Although not shown, in the provided Figures, base portion 26 can be connected to and/or may be an integrated part of electrode 14, for example, as shown in Figure 5B. Figures 9A-9C provide alternate embodiments of optically interactive surface 30 as provided by base portion 26, wherein optically interactive surface 30 may be hemispherical in shape or provided in a more angular/planar design. The design of optically interactive surface may vary depending on the physical requirements of the optical system and the desired interaction with the optical signal emitted and reflected by the associated optical sensor or sensors. In alternate embodiments, as shown in Figures 9D-9F, refractive media 31 may be further provided by base portion 26 to optically interact with the signal (i.e., light) generated by optical sensor 16 of the present invention. The media may be prismatic or plano-convex. Moreover, optically interactive surface 30 may further be provided in connection with the media 31. Media 31 may further include various lens, filters or other types of structures generally known to interact with optical signals (i.e., light).

[0027] As generally illustrated in Figures 6-8, base portion 26 of electrode 14 is positioned within neck portion 52 of the coupling member 50 so that a gap and/or area 64 is provided between optical sensors 16 and optically interactive surface 30. As tip portion 24 of electrode 14 is exposed to external force through contact with tissue, neck portion 52 of coupling member 50 moves relative to tip 24 of electrode 14. Gap 64 may vary in size de-

pending on the size of the electrode, as well as the desired optical interaction between the electrode and the optical sensor. The length (1) of gap 64 correlates to the size of elastic coupling 60 as provided by neck portion 54 of coupling member 50.

[0028] An alternate embodiment, the volume of the area generally defined by gap 64 may also be filled, in whole or in part, with a medium 33 that transmits/transfers light. Medium 33 may further allow for the optical interaction of optical sensor 16 with surface 30 associated with electrode 14. Accordingly, the optical signal emitted from optical sensor 16 may be transmitted either through medium 33 or may directly interact with optically interactive surface 30 depending on the position and/or orientation of catheter 12 and the design of the assembly. The interaction and orientation of the signal may be correlated to determine an associated amount of external force exerted on electrode 14 disposed on catheter 12, and may provide information concerning the orientation of the electrode 14. Moreover, the assembly may be calibrated to better ensure appropriate correlation. The optical signal is then reflected or refracted after interacting with optically interactive surface 30 and received by optical sensor 16. The optical signal (e.g., light energy) is emitted by emitter 34 and received by receiver 32 of optical sensor 16.

[0029] As can be seen in Figures 10A-10B, alternate configurations of medium 33 are shown. In particular, medium 33 may be positioned within the optical assembly such that the proximal surface of the medium 33 may be coupled to or in proximity with optical sensor 16, while the distal surface of medium 33 may be positioned in proximity to base portion 26 of electrode 14. Base portion 26 of electrode 14 includes optically interactive surface 30. In an alternate configuration, medium 33 is provided to optically interact with the optical signal generated by optical sensor 16, in particular, emitter 34, therein refracting the optical signal for transmitting to receiver 32. Medium 33 may include air, gel, liquid or other types of compliant materials known in the industry that are suitable for the environment and do not unacceptably interfere with the operation of the electrode 14 or the optical sensor 16. In an embodiment, medium 33 may be encapsulated within a compliant retaining structure. Medium 33 may be compressible such that the material is responsive to external force as exerted on electrode 14. In an alternate embodiment, medium 33 may comprise a gel or liquid like material dispersed with a solid or solid particulate such that light is dispersed or refracted (i.e. scattered) by the particulate. An alternate embodiment may provide a liquid or gel-like material that further includes suspended particles (i.e. air or liquid bubbles) that would refract the optical signal provided by emitter 34 to receiver 32. Figure 10B illustrates another embodiment, wherein opaque partitions 35 are positioned among medium 33, such that the optical signals emitted by each optical sensor 16 essentially cannot interfere with one another. Such a configuration can aid in reducing "cross-talk" and/or interfer-

ence among each of the optical sensors 16.

[0030] A fiber assembly is further provided by the present invention. The fiber assembly includes a supply fiber and a return fiber. The supply fiber (not shown) is connected to emitter 34 and carries light energy from a light source to emitter 34. The return fiber (not shown) carries reflected light from receiver 32 back to a processor and display unit. The light energy emitted by optical sensor 16 is compared to the light received by optical sensor 16 and used to determine the relative force exerted on electrode 14 based on the orientation of electrode 14 and in connection with catheter 12.

[0031] Figure 7 illustrates an alternate embodiment of assembly 10 wherein least one lumen 66 is included for receiving various energizing or sensing components. Lumen 66 is provided for receiving sensing components such as a thermal sensor, pressure sensor, tissue sensor, electrogram sensor, or other type of sensors and combinations thereof that are known by those of ordinary skill in the art. An additional lumen 68 extends from catheter 12 through coupling member 50 and into electrode 14, therein providing an energizing component, such as source for radiofrequency current, direct current, high-intensity ultrasound, laser, cryogenics, or other type of energizing component and combinations that are known by those of ordinary skill in the art. Additional lumens may be provided by assembly 10 for communication with additional components for the assembly, such as electrical components, fluid (i.e. saline) passageways, or others known in the industry.

[0032] As can be seen in Figures 7 and 8, electrode 14 may have alternate tip configurations depending on the type of procedure or use of the catheter assembly. As previously suggested, electrode 14 may be provided having an irrigated electrode tip or a non-irrigated electrode tip. Each of these may be used in connection with embodiments of the present invention.

[0033] The present invention further discloses an optic-based catheter system 100, as shown in Figures 11A-11F, that includes assembly 10 of the present invention connected to a signal converter 110 (such as an analog to digital converter) and an operator interface 120, which may further include a computer and display, for processing the optical signals received from assembly 10 in connection with positioning and contact with tissue, such as myocardial tissue 105. This optic-based information is processed to determine the contact force exerted on electrode 14 of assembly 10. A calibration system 130 (i.e., calibration software) may be further provided to readily correlate the amplitude or intensity of the received signal to the external force on the electrode. A mapping system 140, such as the EnSite system, also known as NavX®, may be integrated with system 100 to provide a visualization and mapping system for use in connection with assembly 10 of the present invention. In an alternate embodiment, as shown in Figures 11D-11F, the signal processor may be integrated with each of the receivers provided by optical sensor 16, such that the optical signal

is directly processed and provided on the operator interface. Moreover, in another alternate embodiment, as shown in Figures 11G-11I, the emitter and receiver may use the same optical fiber for transmitting and receiving the optical signal. Accordingly a splitter 150, as known by one of ordinary skill in the art, may be used to manage the transmission and receiving of the optical signal for processing. Overall, each of these components may be modified and/or integrated with one another depending on the design of the optical system as recognized by one of ordinary skill in the art.

[0034] The contact sensing assembly and system of the present invention can be used for sensing contact force and/or orientation. Said use includes directing light or energy from a source through an optical sensor within a catheter; emitting light or energy from the optical sensor across a spaced gap for interacting with an optically-interactive surface provided in connection with an electrode; and receiving reflected light or energy by the optical sensor. The reflected light or energy may be processed by a processor to determine a change between the light or energy emitted from the optical sensor and the reflected light energy correspondingly received by the optical sensor. The changes may be correlated to, among other things, force vectors exerted by the electrode on an adjacent tissue.

[0035] In particular, under normal conditions of zero-contact force (i.e. when the electrode is not subjected to external forces), the plane of reflection as provided by either optically interactive surface 30, media 31 or medium 33, alone or in combination with one another as the case may be, is generally parallel to the plane of emitters 34 as previously described. Accordingly, the amplitude or intensity of the optical signal (i.e., light) received by receivers 32 is substantially the same or proportionally constant depending on the properties of the interactive surface. When the electrode contacts a surface, the contact force modifies the plane of reflection provided by the respective interactive surface (30, 31, or 33). In particular, upon the exertion of axial force (F_a) on the electrode, the plane of reflection is pushed closer to the place of emitters due to the spring-like configuration and/or flexibility exhibited by distal end 20 of catheter 12. Similarly, upon the exertion of lateral force (F_l), the plane of reflection is tilted with respect to the plane of emitters. The change in amplitude or intensity of the reflected optical signal (i.e. light) received by each of the receivers relative to one another results in the calculation of the lateral force exerted on the external surface of the electrode. The change in amplitude or intensity of the reflected light relative to the zero-axial-force condition can be used to determine the axial force being exerted on the electrode. As a result, the net contact force is given by the vector sum of the axial and lateral force, and the direction relative to the axis may be calculated. Overall, the force, either axial, lateral or a combination of both, is determined based on the change of intensity of the optical signal received by the receivers which is proportional to the dis-

placement and/or movement of the distal end 20 of catheter 12. In the present disclosure, all joinder references (e.g., attached, coupled, connected, and the like) are to be construed broadly and may include intermediate members between a connection of elements and relative movement between elements. As such, joinder references do not necessarily infer that two elements are directly connected and in fixed relation to each other.

Claims

1. A contact sensing assembly (10) comprising:

a catheter (12) including a body having a proximal end (22) and a distal end (20);
 an electrode (14) including a tip portion (24) and a base portion (26); and
 an optical sensor (16),

wherein the base portion (26) of the electrode (14) includes an optically interactive surface (30); a portion of the electrode (14) is connected to the distal end of the catheter (12); and the optical sensor (16) is spaced from the optically interactive surface (30), and is configured to detect changes in the reflected energy from the optically interactive surface (30), wherein the distal end (20) of the catheter includes a coupling member (50) having a neck portion (52), wherein the neck portion (52) of the coupling member (50) includes an elastic portion (60) that is adapted to move relative to an external force exerted on the electrode (14) such that at least a portion of distal end (20) of catheter (12) flexes and/or bends relative to electrode (14),

wherein the optical sensor (16) includes a plurality of emitters (34) and a plurality of receivers (32), respectively configured for emitting and receiving an optical signal to and from the optically interactive surface (30), and

wherein the plurality of emitters (34) and the plurality of receivers (32) are distributed about the peripheral wall of a fiber optic cable (38), such that each emitter (34) operatively interacts with at least one receiver (32).

2. The assembly (10) of claim 1, wherein the electrode (14) comprises the lumen (42) provided with an internal cavity of the electrode (14), the lumen (42) positioned adjacent to the base portion (26) and tip portion (24) of the electrode (14).

3. The assembly (10) of claim 1 or 2, wherein the assembly (10) further includes a refractive media or medium (33),

4. The assembly (10) of claim 3, wherein the refractive media or medium (33) includes a reflective surface.

5. The assembly (10) of any one of claims 1 to 4, wherein the emitter (34) and receiver (32) are adjacent to one another and are paired.
6. The assembly (10) of claim 1, comprising a lumen (66, 68) disposed within the body of the catheter (12), at least a portion of the lumen (66, 68) extending into the electrode (14) for slidably receiving at least one sensing component and/or for slidably receiving at least one energizing component.
7. The assembly (10) of claim 6, wherein the sensing component is selected from a thermal sensor, pressure sensor, tissue sensor, electrogram sensor, and combinations thereof.
8. The assembly (10) of any one of the preceding claims, wherein the fiber optic cable (38) comprises at least one lumen (42) and a peripheral wall (40) surrounding the lumen (42), wherein the optical sensor (16) is connected to the peripheral wall (40).
9. The assembly (10) of claim 8, wherein a plurality of optical sensors (16) are disposed within the body of the catheter (12), each optical sensor (16) having a means (32, 34) for emitting and receiving light energy.
10. The assembly (10) of any one of the preceding claims, wherein the optical sensor (16) is adapted to measure a parameter selected from the group consisting of intensity, wavelength, phase, spectrum, speed, optical path, interference, transmission, absorption, reflection, refraction, diffraction, polarization, and scattering.
11. An optically-based catheter system (100) comprising:
- a contact sensing assembly (10) of any one of the preceding claims,
 - a light or energy source;
 - a processor (110, 120),
 - a catheter mapping unit (140) for use in mapping or visualizing the catheter location; and
 - a fiber assembly for carrying light energy that is emitted, is reflected by the optically-interactive surface, and is received by the optical sensor.
- Patentansprüche**
1. Kontakterfassungsaufbau (10) mit:
- einem Katheter (12), der einen Körper mit einem proximalen Ende (22) und einem distalen Ende (20) aufweist;
 - einer Elektrode (14), die einen Spitzenbereich (24) und einen Basisbereich (26) aufweist; und einem optischen Sensor (16), wobei der Basisbereich (26) der Elektrode (14) eine optisch interaktive Oberfläche (30) aufweist; ein Bereich der Elektrode (14) mit dem distalen Ende des Katheters (12) verbunden ist; und der optische Sensor (16) von der optisch interaktiven Oberfläche (30) beabstandet und konfiguriert ist zum Detektieren von Änderungen der von der optisch interaktiven Oberfläche (30) reflektierten Energie, wobei das distale Ende (20) des Katheters ein Kupplungsbauteil (50) mit einem Ansatzbereich (52) aufweist, wobei der Ansatzbereich (52) des Kupplungsbauteils (50) einen elastischen Bereich (60) aufweist, der angepasst ist zur relativen Bewegung aufgrund einer externen Kraft, die auf die Elektrode (17) derart ausgeübt wird, dass mindestens ein Bereich des distalen Endes (20) des Katheters (12) sich relativ zu der Elektrode (14) bewegt und/oder biegt, wobei der optische Sensor (16) eine Mehrzahl von Emitttern (34) und eine Mehrzahl von Empfängern (32) aufweist, die jeweils konfiguriert sind zum Aussenden und Empfangen eines optischen Signals an und von der optisch interaktiven Oberfläche (30), und wobei die Mehrzahl der Emittter (34) und die Mehrzahl der Empfänger (32) über der Umfangswand eines faseroptischen Kabels (38) verteilt sind, so dass jeder Emittter (34) mit mindestens einem Empfänger (32) operativ interagiert.
2. Aufbau (10) nach Anspruch 1, bei dem die Elektrode (14) ein Lumen (42) aufweist, das mit einem internen Hohlraum der Elektrode (14) versehen ist, wobei das Lumen (42) benachbart zu dem Basenbereich (26) und dem Spitzenbereich (24) der Elektrode (14) positioniert ist.
3. Aufbau (10) nach Anspruch 1 oder 2, bei dem der Aufbau (10) ferner ein Brechungsmedium oder ein Medium (33) aufweist.
4. Aufbau (10) nach Anspruch 3, bei dem die Brechungsmedium oder das Medium (33) eine Brechungsfläche aufweist.
5. Aufbau (10) nach einem der Ansprüche 1 bis 4, bei dem der Emittter (34) und der Empfänger (32) zueinander benachbart und paarweise ausgebildet sind.
6. Aufbau (10) nach Anspruch 1, mit einem Lumen (66, 68), das sich innerhalb des Körpers des Katheters (12) befindet, wobei mindestens ein Bereich des Lumens (66, 68) sich in die Elektrode erstreckt zur gleitenden Aufnahme von mindestens einer Erfas-

sungskomponente und/oder zum gleitenden Aufnehmen von mindestens einer Energetisierungskomponente.

7. Aufbau (10) nach Anspruch 6, bei dem die Erfassungskomponente ausgewählt ist aus einem thermischen Sensor, Drucksensor, Gewebesensor, Elektrogrammsensor und aus Kombinationen davon. 5
8. Aufbau (10) nach einem der vorangegangenen Ansprüche, bei dem das faseroptische Kabel (38) mindestens ein Lumen (42) und eine Umfangswand (40), die das Lumen (42) umgibt, aufweist, wobei der optische Sensor (16) mit der Umfangswand (40) verbunden ist. 10
9. Aufbau (10) nach Anspruch 8, bei dem eine Mehrzahl von optischen Sensoren (16) innerhalb des Körpers des Katheters (12) angeordnet sind, wobei jeder optische Sensor (16) ein Mittel (32, 34) aufweist zum Aussenden und Empfangen von Lichtenergie. 20
10. Aufbau (10) nach einem der vorangegangenen Ansprüche, bei dem der optische Sensor (16) angepasst ist zum Messen eines Parameters, der ausgewählt ist aus der Gruppe, die besteht aus Intensität, Wellenlänge, Phase, Spektrum, Geschwindigkeit, optischer Pfad, Interferenz, Transmission, Absorption, Reflexion, Refraktion, Diffraktion, Polarisation und Streuung. 25
11. Optisch basiertes Kathetersystem (100) mit:
 - einem Kontakterfassungsaufbau (10) nach einem der vorangegangenen Ansprüche;
 - einer Licht- oder Energiequelle;
 - einem Prozessor (110, 120),
 - einer Katheterabbildungseinheit (140) zur Verwendung beim Abbilden oder Visualisieren des Katheterorts; und
 - einem Faseraufbau zum Übertragen von Lichtenergie, die ausgesendet, durch die optisch interaktive Oberfläche reflektiert und durch den optischen Sensor empfangen wird. 35

Revendications

1. Ensemble de détection de contact (10) comprenant :
 - un cathéter (12) comprenant un corps ayant une extrémité proximale (22) et une extrémité distale (20) ;
 - une électrode (14) comprenant une partie extrémité (24) et une partie base (26) ; et
 - un capteur optique (16),
 - dans lequel la partie base (26) de l'électrode (14) comprend une surface interactive optiquement

(30) ; une partie de l'électrode (14) est reliée à l'extrémité distale du cathéter (12) ; et le capteur optique (16) est espacé de la surface interactive optiquement (30), et est configuré pour détecter des changements dans l'énergie réfléchie depuis la surface interactive optiquement (30), dans lequel l'extrémité distale (20) du cathéter comprend un élément d'accouplement (50) ayant une partie col (52), dans lequel la partie col (52) de l'élément d'accouplement (50) comprend une partie élastique (60) qui est adaptée pour se déplacer par rapport à une force externe exercée sur l'électrode (14) de sorte qu'au moins une partie de l'extrémité distale (20) du cathéter (12) se plie et/ou se courbe par rapport à l'électrode (14), dans lequel le capteur optique (16) comprend une pluralité d'émetteurs (34) et une pluralité de récepteurs (32), respectivement configurés pour émettre et recevoir un signal optique vers et en provenance de la surface interactive optiquement (30), et dans lequel la pluralité d'émetteurs (34) et la pluralité de récepteurs (32) sont distribués autour de la paroi périphérique d'un câble à fibre optique (38), de sorte que chaque émetteur (34) interagisse de manière fonctionnelle avec au moins un récepteur (32).

2. Ensemble (10) de la revendication 1, dans lequel l'électrode (14) comprend la lumière (42) dotée d'une cavité interne de l'électrode (14), la lumière (42) étant positionnée à proximité de la partie base (26) et de la partie extrémité (24) de l'électrode (14). 30
3. Ensemble (10) de la revendication 1 ou 2, dans lequel l'ensemble (10) comprend en outre un milieu ou support de réfraction (33). 35
4. Ensemble (10) de la revendication 3, dans lequel le milieu ou support de réfraction (33) comprend une surface réfléchissante. 40
5. Ensemble (10) de l'une quelconque des revendications 1 à 4, dans lequel l'émetteur (34) et le récepteur (32) sont proches l'un de l'autre et sont appariés. 45
6. Ensemble (10) de la revendication 1, comprenant une lumière (66, 68) disposée dans le corps du cathéter (12), au moins une partie de la lumière (66, 68) s'étendant dans l'électrode (14) pour recevoir de manière coulissante au moins un élément de détection et/ou pour recevoir de manière coulissante au moins un élément d'alimentation. 50
7. Ensemble (10) de la revendication 6, dans lequel l'élément de détection est choisi parmi un capteur de température, un capteur de pression, un détec-

teur de tissus, un détecteur d'électrogramme, et des combinaisons de ceux-ci.

8. Ensemble (10) de l'une quelconque des revendications précédentes, dans lequel le câble à fibre optique (38) comprend au moins une lumière (42) et une paroi périphérique (40) entourant la lumière (42), dans lequel le capteur optique (16) est relié à la paroi périphérique (40). 5
10
9. Ensemble (10) de la revendication 8, dans lequel une pluralité de capteurs optiques (16) sont disposés dans le corps du cathéter (12), chaque capteur optique (16) ayant un moyen (32, 34) permettant d'émettre et de recevoir de l'énergie lumineuse. 15
10. Ensemble (10) de l'une quelconque des revendications précédentes, dans lequel le capteur optique (16) est adapté pour mesurer un paramètre choisi dans le groupe comprenant l'intensité, la longueur d'onde, la phase, le spectre, la vitesse, le trajet optique, l'interférence, la transmission, l'absorption, la réflexion, la réfraction, la diffraction, la polarisation et la diffusion. 20
25
11. Système de cathéter à base optique (100) comprenant :
- un ensemble de détection de contact (10) de l'une quelconque des revendications précédentes ; 30
 - une source de lumière ou d'énergie ;
 - un processeur (110, 120) ;
 - une unité de mappage de cathéter (140) destinée à être utilisée dans le mappage ou la visualisation de l'emplacement du cathéter ; et 35
 - un ensemble de fibres permettant de transporter de l'énergie lumineuse qui est émise, est réfléchie par la surface interactive optiquement, et est reçue par le capteur optique. 40
- 45
- 50
- 55

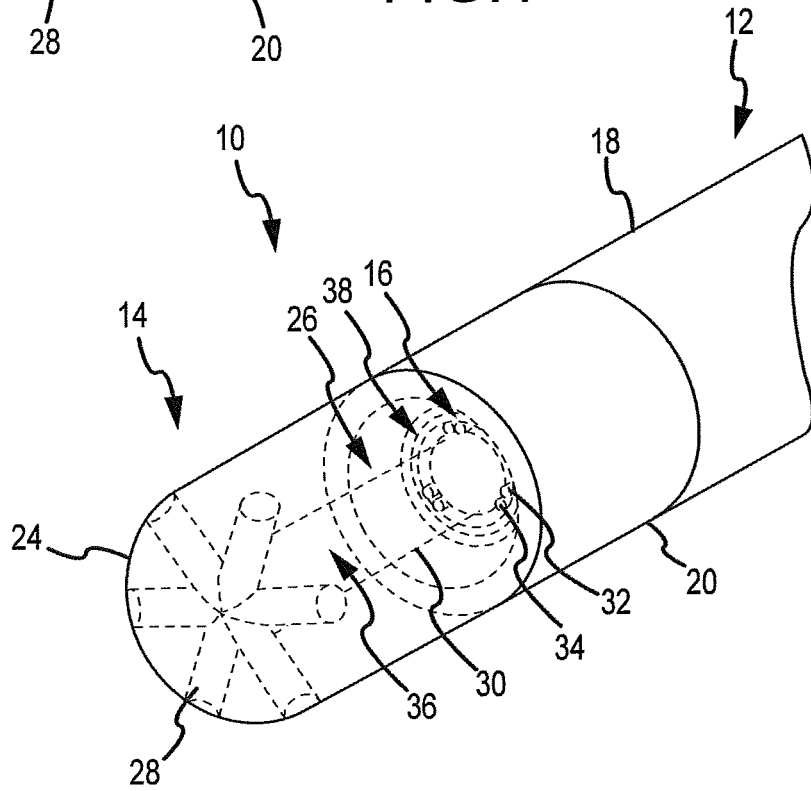
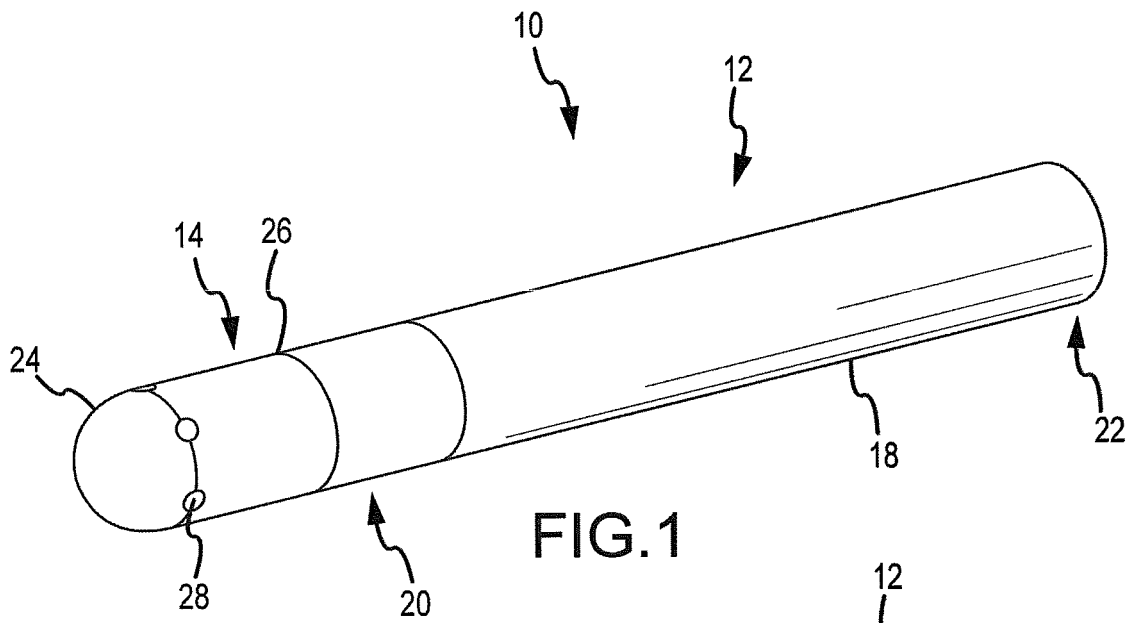

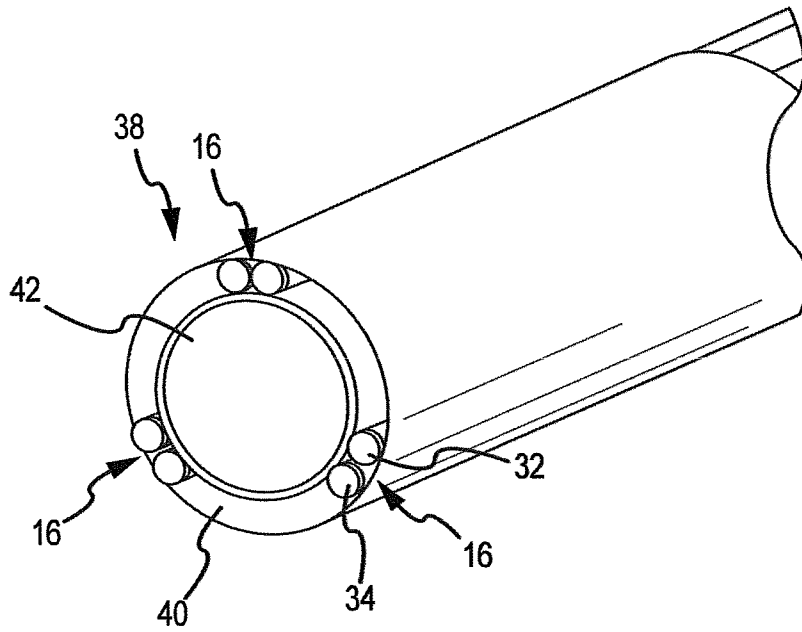

FIG. 3A

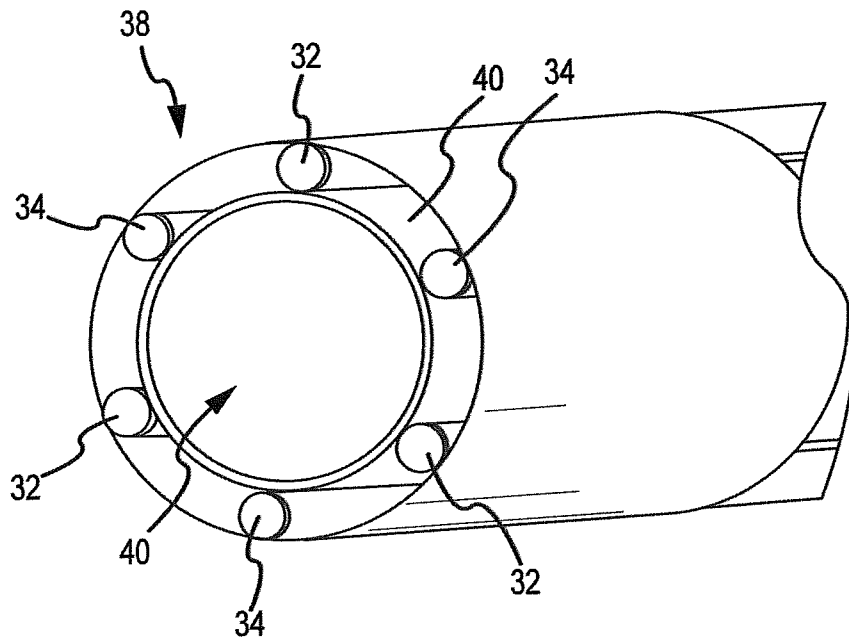

FIG. 3B

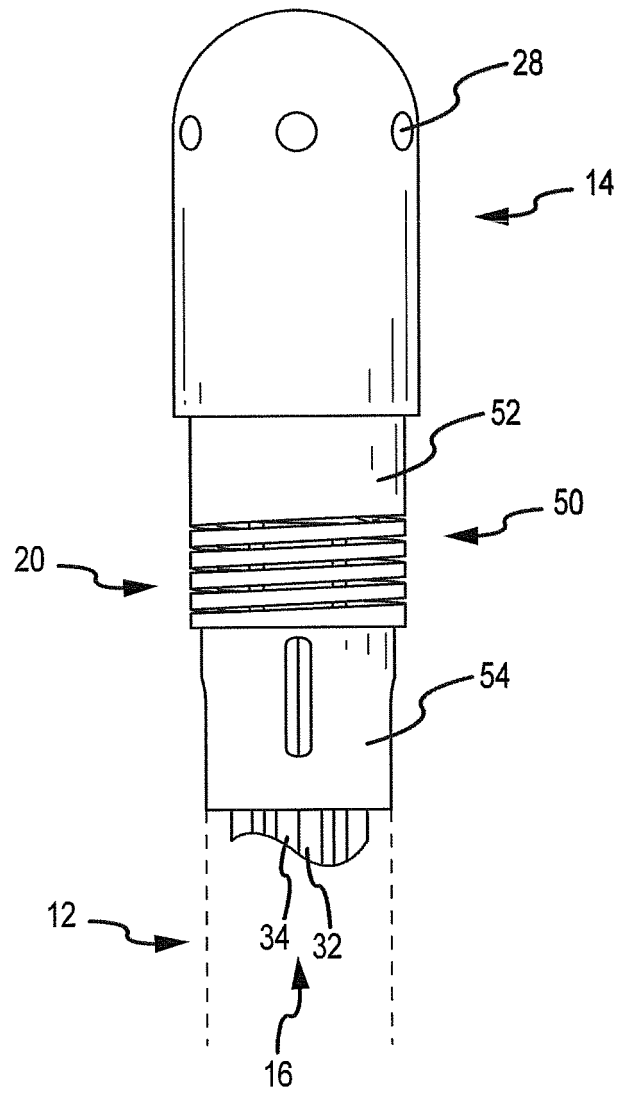

FIG.4

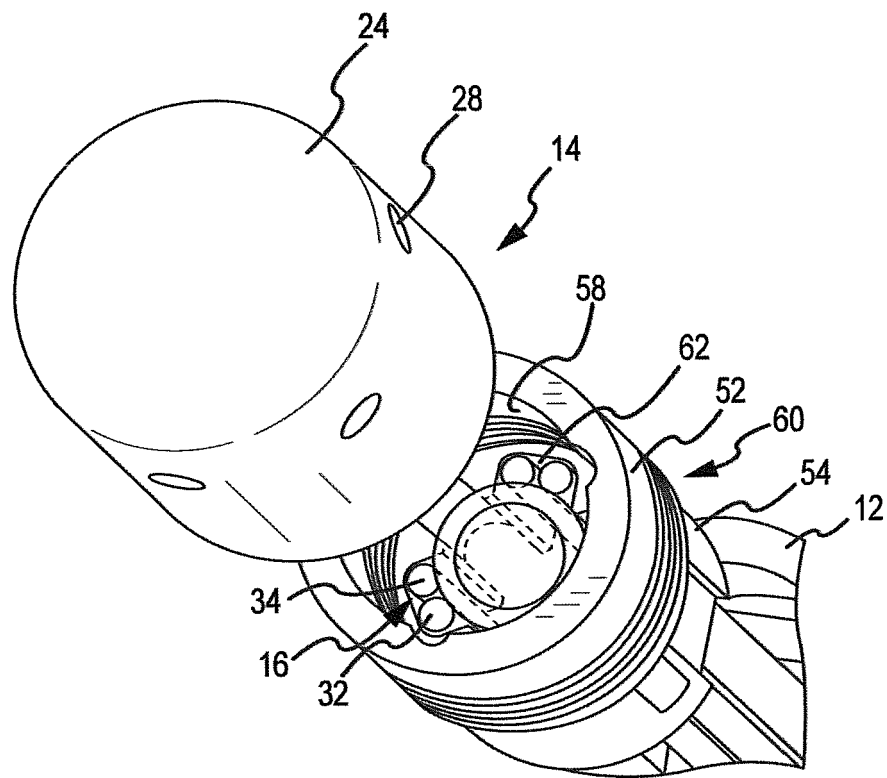

FIG.5A

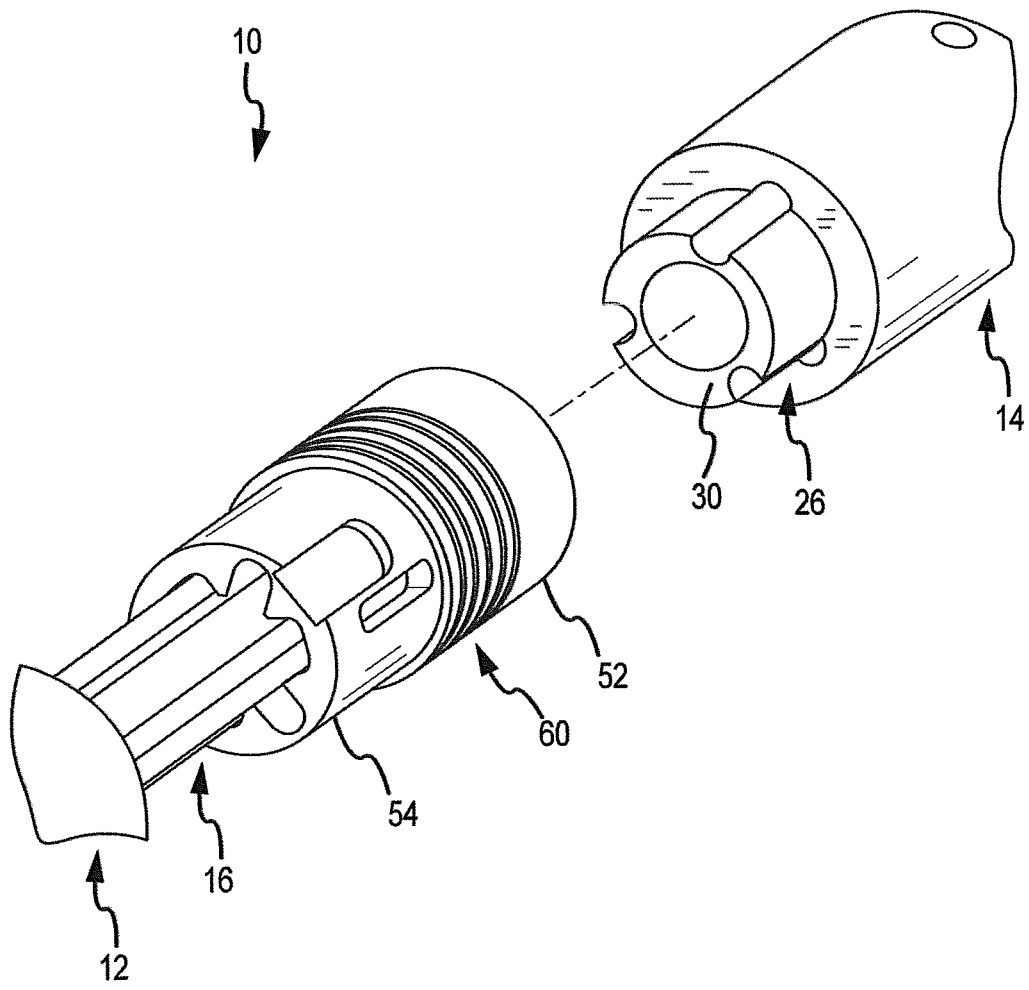

FIG.5B

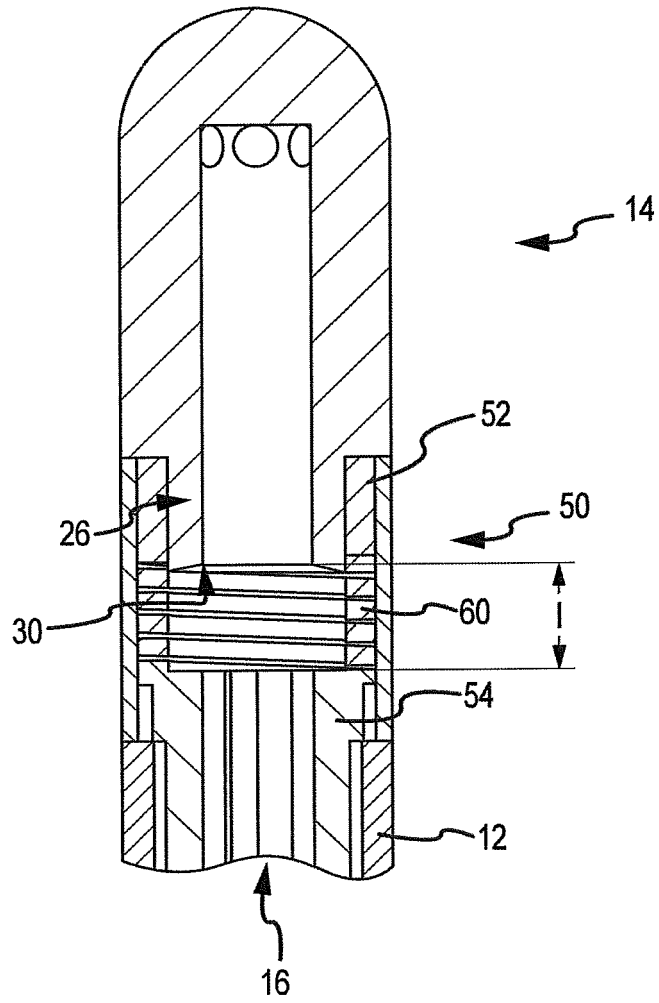
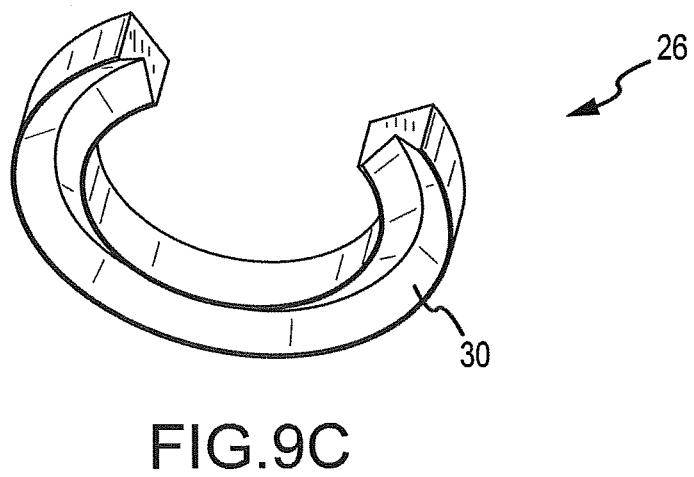
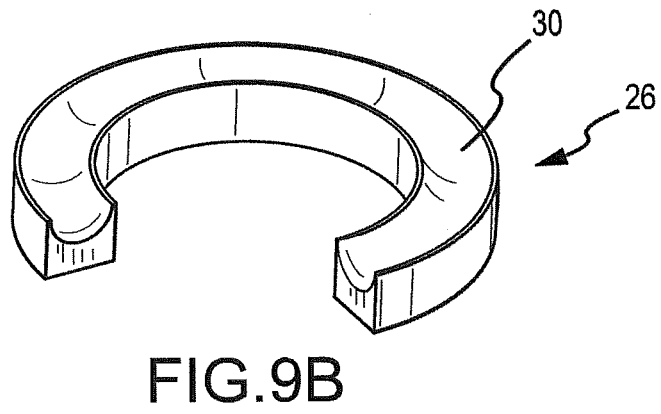
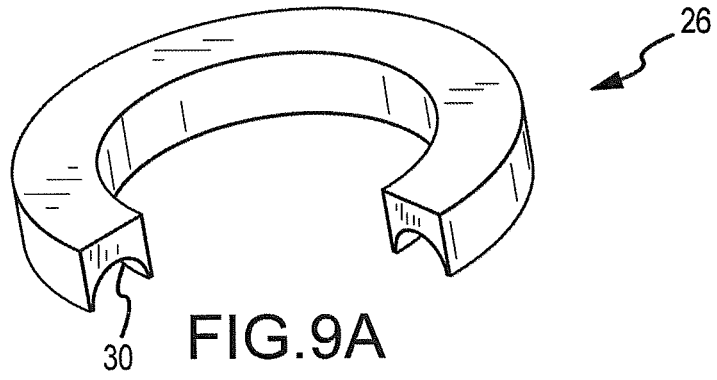

FIG.6



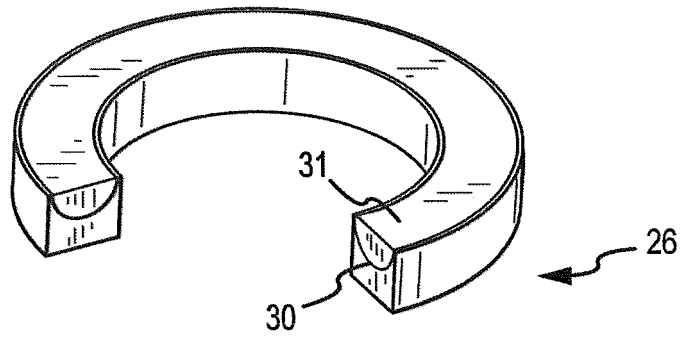

FIG. 9D

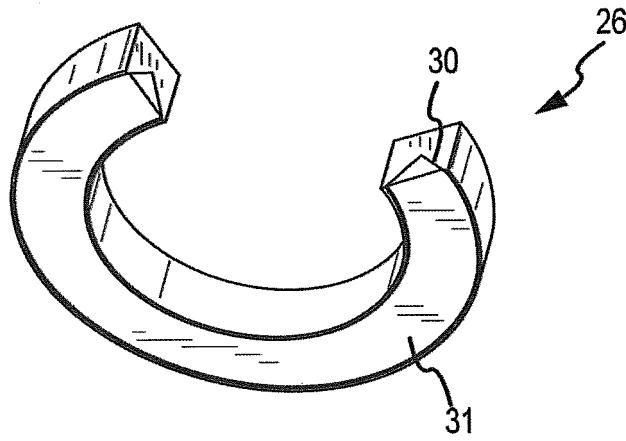

FIG. 9E

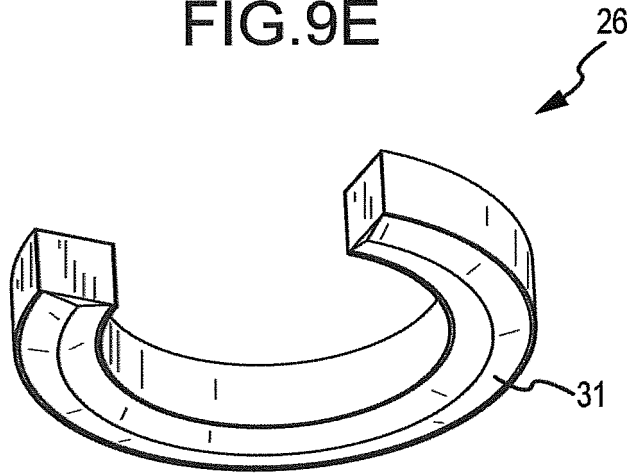

FIG. 9F

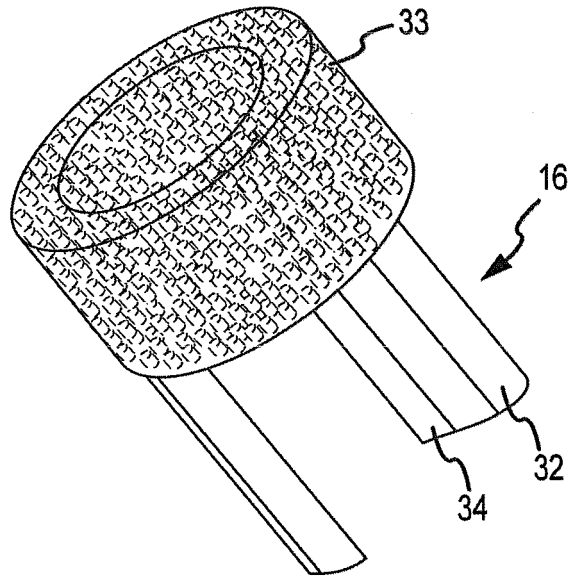

FIG. 10A

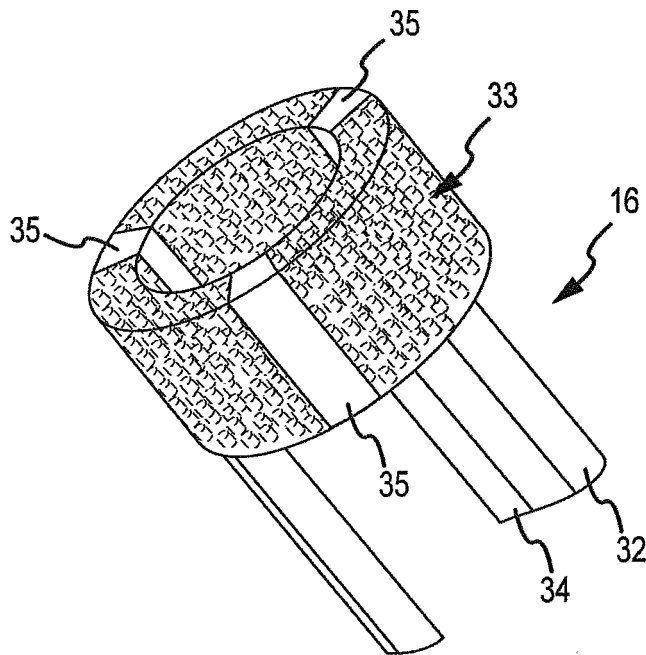

FIG. 10B

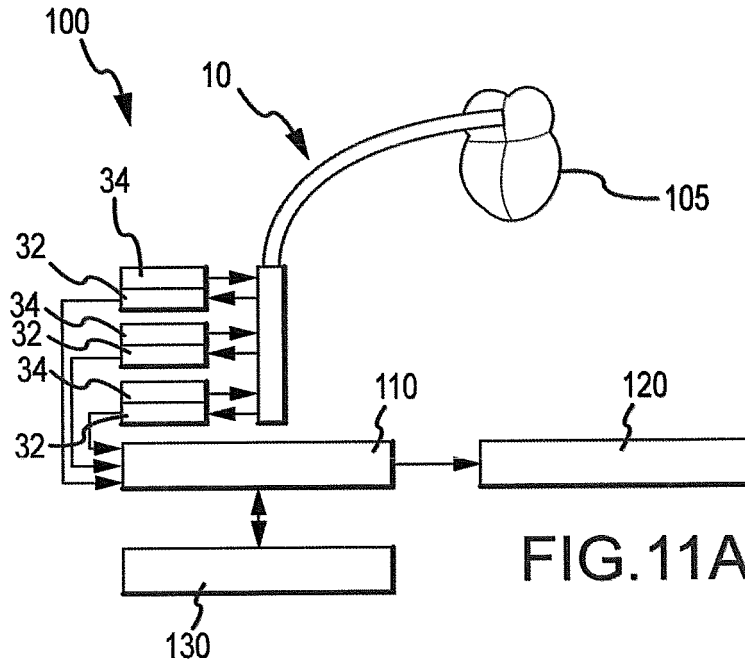

FIG. 11A

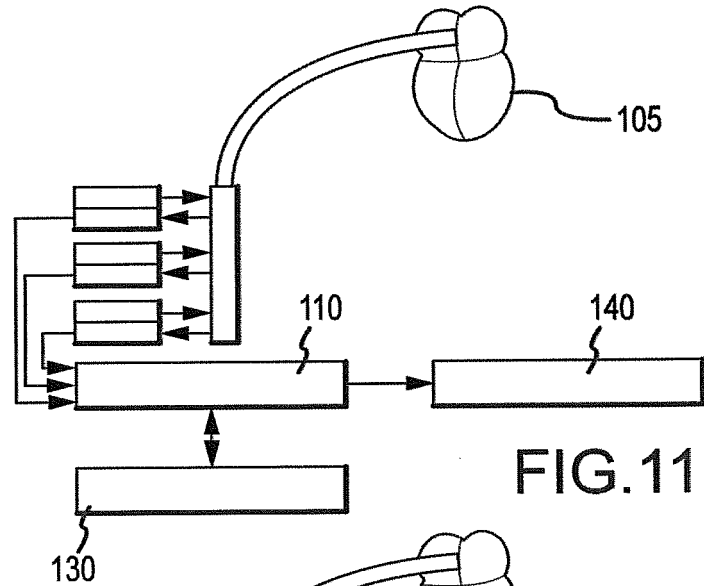

FIG. 11B

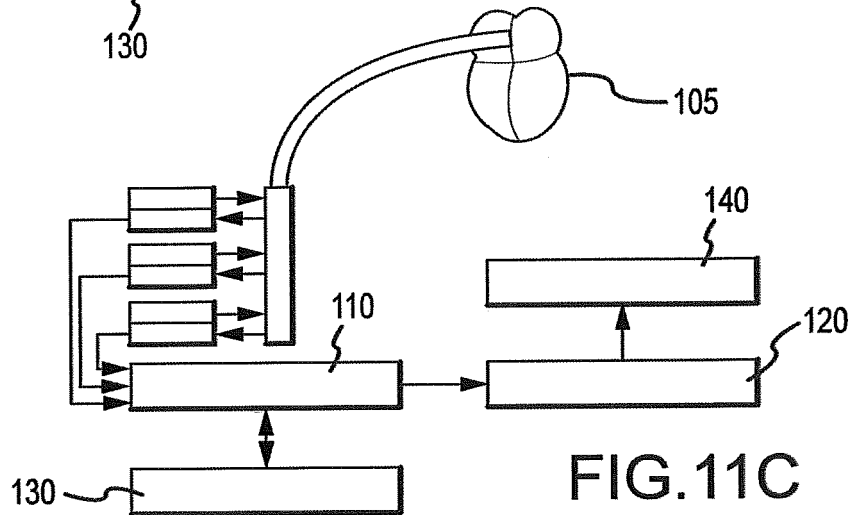
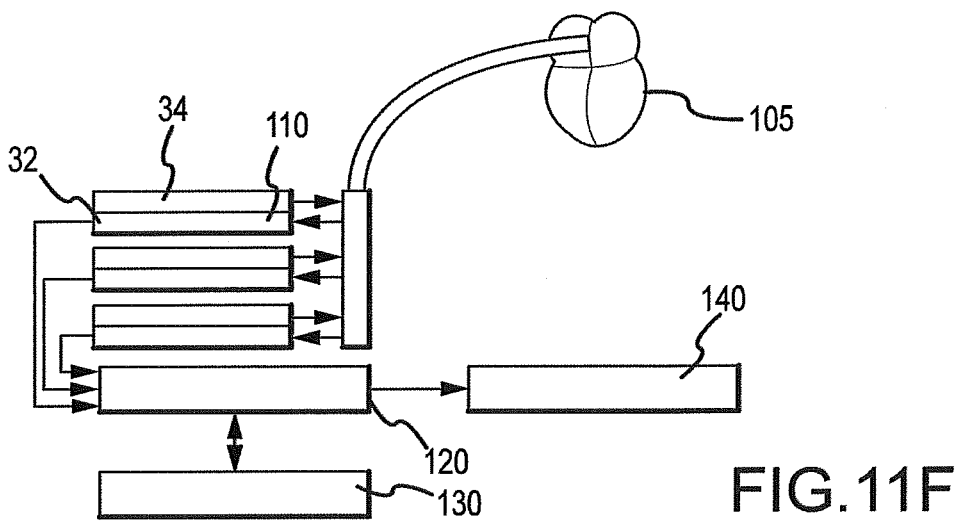
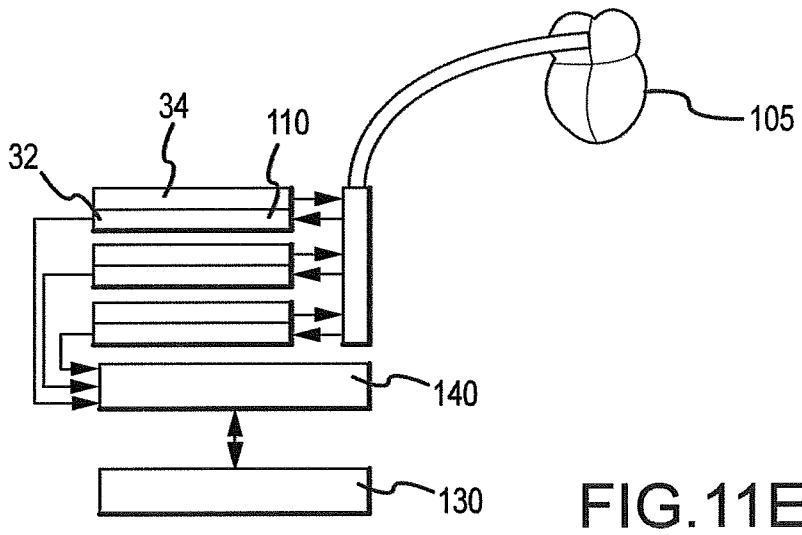
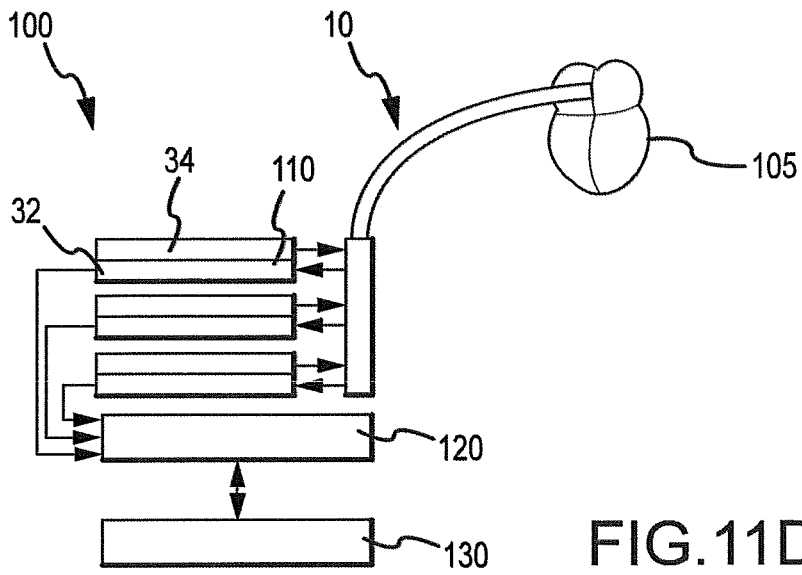
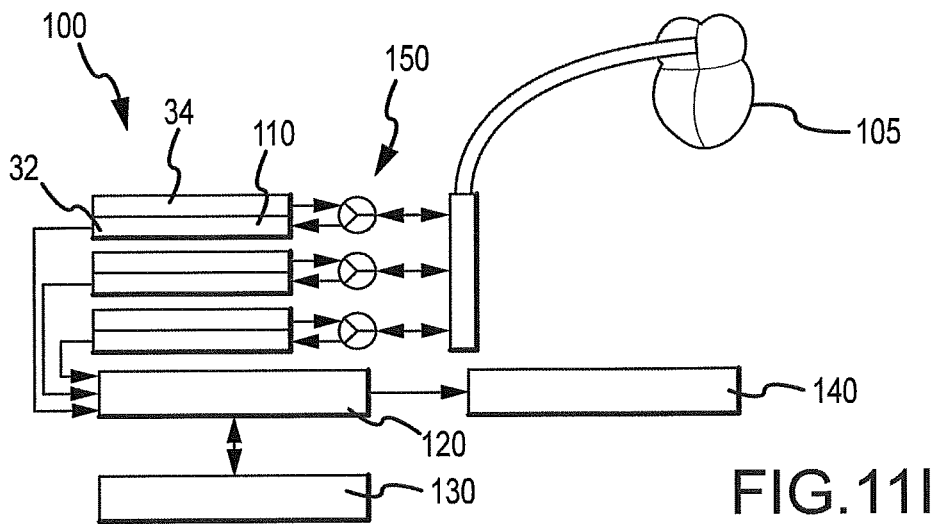
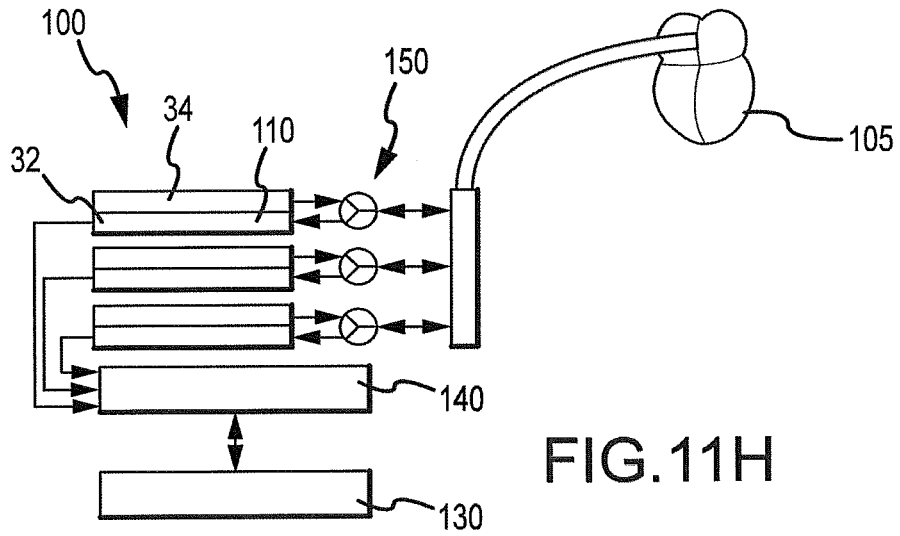
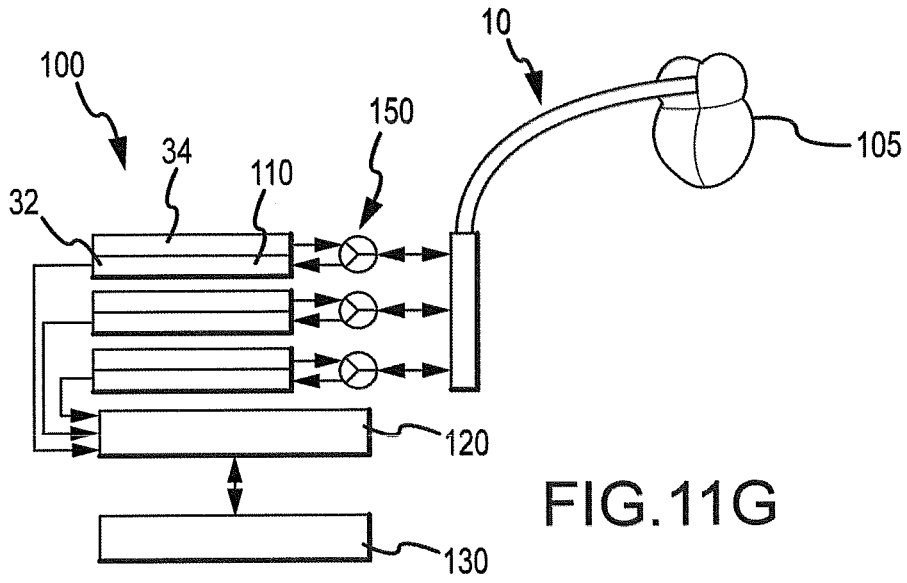

FIG. 11C





REFERENCES CITED IN THE DESCRIPTION

This list of references cited by the applicant is for the reader's convenience only. It does not form part of the European patent document. Even though great care has been taken in compiling the references, errors or omissions cannot be excluded and the EPO disclaims all liability in this regard.

Patent documents cited in the description

- US 20070060847 A1 [0006]
- WO 2004069072 A2 [0007]
- GB 2331580 A [0008]
- US 43422006 A [0017]
- US 10595608 B [0017]
- US 11646270 B [0017]
- US 11647346 B [0017]
- US 60828955 B [0017]

专利名称(译)	基于光学的接触传感组件和系统		
公开(公告)号	EP2142088A4	公开(公告)日	2012-08-01
申请号	EP2008746501	申请日	2008-04-22
[标]申请(专利权)人(译)	圣犹达医疗用品电生理部门有限公司		
申请(专利权)人(译)	ST.犹达医疗用品, 房颤DIVISION, INC.		
当前申请(专利权)人(译)	ST.犹达医疗用品, 房颤DIVISION, INC.		
[标]发明人	TEGG TROY T PAUL SAURAV STEHR RICHARD E HEIMBECHER REED R		
发明人	TEGG, TROY T. PAUL, SAURAV STEHR, RICHARD E. HEIMBECHER, REED R.		
IPC分类号	A61B5/05 A61B5/00 A61B17/00 A61B18/14 A61B18/24 A61B90/00 A61M25/00		
CPC分类号	A61B5/0084 A61B5/6852 A61B5/6885 A61B18/1492 A61B18/24 A61B2017/00057 A61B2017/00084 A61B2090/065 A61M25/0069 A61M25/007 A61M25/0071 A61M2025/0002 A61B5/6886		
代理机构(译)	KRAMER - HARSH - 施密特陈		
优先权	60/915387 2007-05-01 US 11/941073 2007-11-15 US		
其他公开文献	EP2142088B1 EP2142088A1		
外部链接	Espacenet		

摘要(译)

本发明涉及基于光学的感测组件和包含该组件的系统以及该组件的相关用途。特别地, 本发明涉及用于确定导管(12)与周围的周围环境(例如组织)之间的接触的基于光学的导管组件(10)和相关系统。这样的系统的实施例可以例如用于可视化, 映射, 消融或其他诊断和治疗组织和/或周围区域的方法。