



(11) **EP 1 828 753 B1**

(12) **EUROPEAN PATENT SPECIFICATION**

(45) Date of publication and mention of the grant of the patent:
13.04.2011 Bulletin 2011/15

(51) Int Cl.:
G01N 21/65^(2006.01) G01N 21/49^(2006.01)
G01N 21/47^(2006.01) A61B 5/00^(2006.01)

(21) Application number: **05809242.0**

(86) International application number:
PCT/GB2005/004535

(22) Date of filing: **25.11.2005**

(87) International publication number:
WO 2006/061566 (15.06.2006 Gazette 2006/24)

(54) **APPARATUS FOR DEPTH-SELECTIVE RAMAN SPECTROSCOPY**

VORRICHTUNG ZUR TIEFENSELEKTIVEN RAMAN-SPEKTROSKOPIE

DISPOSITIF DE SPECTROSCOPIE RAMAN A PROFONDEUR SELECTIVE

(84) Designated Contracting States:
AT BE BG CH CY CZ DE DK EE ES FI FR GB GR HU IE IS IT LI LT LU LV MC NL PL PT RO SE SI SK TR

(30) Priority: **09.12.2004 GB 0426993**
11.04.2005 US 669880 P

(43) Date of publication of application:
05.09.2007 Bulletin 2007/36

(73) Proprietor: **The Science and Technology Facilities Council**
Didcot, Oxfordshire OX11 0QX (GB)

(72) Inventors:
• **MATOUSEK, Pavel**
Abingdon Oxfordshire OX14 5HD (GB)
• **PARKER, Anthony, William**
Swindon Wiltshire SN5 6JT (GB)

(74) Representative: **Palmer, Jonathan R.**
Boult Wade Tennant
Verulam Gardens
70 Gray's Inn Road
London WC1X 8BT (GB)

(56) References cited:
WO-A-00/20843 WO-A-92/15008
WO-A-96/26431 US-A- 5 349 961
US-A- 5 625 458 US-A- 5 752 519
US-A- 5 935 062 US-A1- 2003 220 549
US-A1- 2004 054 270 US-B1- 6 310 686

- **DUNSBY C ET AL: "TECHNIQUES FOR DEPTH-RESOLVED IMAGING THROUGH TURBID MEDIA INCLUDING COHERENCE-GATED IMAGING" JOURNAL OF PHYSICS D. APPLIED PHYSICS, IOP PUBLISHING, BRISTOL, GB, vol. 36, 2003, pages R207-R227, XP001090968 ISSN: 0022-3727**
- **MATOUSEK P; TOWRIE M; PARKER A W: "Fluorescence background suppression in Raman spectroscopy using combined Kerr gated and shifted excitation Raman difference techniques" JOURNAL OF RAMAN SPECTROSCOPY, vol. 33, no. 4, April 2002 (2002-04), pages 238-242, XP002366725 UK**

EP 1 828 753 B1

Note: Within nine months of the publication of the mention of the grant of the European patent in the European Patent Bulletin, any person may give notice to the European Patent Office of opposition to that patent, in accordance with the Implementing Regulations. Notice of opposition shall not be deemed to have been filed until the opposition fee has been paid. (Art. 99(1) European Patent Convention).

Description

Field of the Invention

[0001] This invention relates to the field of Raman spectroscopy and, in particular, to apparatus for detecting Raman spectral features non-destructively from sub-surface regions within a macroscopic diffusely scattering sample.

[0002] Diffusely scattering media are frequently encountered in many analytical applications. Examples of such analytical applications include but are not limited to monitoring of food products, colloids, polymers, catalysts, powders in general, coating technology and medical applications involving the probing of tissue and biochemical identification in medical studies and treatments. The samples encountered in such analytical applications are often highly heterogeneous and can be made of various layers each having a different chemical make-up. Therefore, a major goal for analytical science is to provide a method capable of determining the chemical composition of sub-surface layers in a non-destructive way.

[0003] The benefits that can be derived from the analysis of chemical compositions can be illustrated using the example of non-invasive Raman probing of bones where signal quality from bone can be crucial in arriving at an accurate and correct diagnosis as to whether disease is present (see A. Carden and M. D. Morris, J. Biomed. Optics 5, 259 (2000)). Conventional Raman signatures of bone collagen are masked by undesired Raman signals from overlaying tissue and so data on chemical composition is generally obtained by means of a biopsy.

[0004] The separation of Raman spectral components derived from a surface layer of a sample and from a sub-surface layer of the same sample would be highly desirable in many analytical applications. This task is, however, hugely complicated due to an inability to form sharp optical images from within turbid media of the overlying material by conventional optical methods such as confocal microscopy, which is only applicable typically to depths of the order of the transport length of the scattering medium (the transport length describes the average distance photons travel before deviating significantly from their original direction of propagation). This length is typically around ten times the mean free scattering path of photons in the medium. For example, in biological tissue this corresponds to depths of around several hundred micrometres.

Description of the Prior Art

[0005] Infrared and Raman spectroscopies are known to provide a wealth of information on the physio-chemical state of a wide range of biological tissues and fluids (see, for example US 6,681,133 or WO 01/52739). Unfortunately analysis by these methods has largely been limited to surface studies.

[0006] Elastically scattered photons have been used to probe beneath a scattering surface for compositional information. For example, B.B.Das, et al. in Rep. Prog. Phys. 60, 227 (1997) describes an approach using temporal gating. This technique relies on the fact that it takes a finite time for light to penetrate a diffusely scattering medium. Scattering events will therefore occur later at lower depths, and so monitoring a scattered signal over time should, theoretically, provide information as to the nature of the scattering centres at progressively greater depths. The elastic scattering technique of Das et al. is, however, not directly applicable to Raman spectroscopy. Inelastic scattering of photons has a far smaller cross-section, resulting in a much weaker signal. Furthermore the Raman signal is far more susceptible to interference from luminescence and in particular fluorescence when analysing tissue.

[0007] WO 96/26431 relates to the use of time gated scattered light, for determining the location and composition of material within various organs of the human body, and providing for medical imaging in three dimensions of internal body structures for diagnostic purposes.

Summary of the Invention

[0008] It is an object of this invention, therefore, to provide an analysis technique based on Raman spectroscopy that is capable of extracting sub-surface chemical compositional information.

[0009] Accordingly, the invention provides a method of measuring sub-surface Raman scattering through a diffusely scattering sample as set out in claim 1, and apparatus as set out in claim 31.

[0010] Embodiments of the invention provide a method of measuring sub-surface Raman scattering through a diffusely scattering sample or medium, to thereby determine characteristics of the sub-surface region.

[0011] Just a single spacing between the entry and collection regions may be required to obtain information about a sub-surface layer if sufficient prior knowledge is available, such as intensities of expected Raman features of the near surface region of the sample. However, by determining Raman spectral intensities at a variety of spacings more accurate information can be derived, for example using techniques described in more detail below.

[0012] A reference collection region may also be provided at substantially the same place or overlapping with the entry region, for comparison with a spaced collection region. Advantageously, such a collocated reference collection region may share common optics with the light source supplying the incident radiation.

[0013] A variety of collection region and entry region geometries are possible. In one preferred embodiment the collection region forms an annulus around the entry region. Multiple such annular collection regions, or a single variable radius region may be used to derive more depth related data, and the arrangement may be re-

versed by placing a single fixed or variable or multiple annular entry region around a central collection region. It should be noted that the annular regions may be broken or incomplete and will generally not include full optical coverage within these regions. For example, a circular single thickness array of closely packed optical fibres might attain a 60% coverage.

[0014] A collection region is preferably spaced at least 1 mm and more preferably at least 2 mm from an associated entry region. The depth of a sub-surface layer to be studied will typically be similar to this spacing distance, and the practical dimensions will depend on the optical properties of the sample. The diameter or size of the entry region will generally be less than the spacing of the entry and collection regions, and the entry and collection regions are preferably non-overlapping.

[0015] Embodiments - also provide a method of measuring a sub-surface Raman spectrum of a diffusely-scattering sample, the method comprising the steps of:

- a) irradiating an entry region of the sample with a light probe;
 - b) collecting light scattered by the sample; and
 - c) spectrally separating at least a portion of the collected light to detect one or more Raman spectral features,
- wherein light scattered by the sample is collected from a plurality of spatial locations or collection regions on the surface of the sample, each spatial location being at a different distance from the point of irradiation, at least a portion of the light collected at each spatial location being separately spectrally dispersed to form a plurality of Raman spectra and wherein the method further includes the step of:
- d) analysing the plurality of Raman spectra to extract information on the Raman spectrum of a sub-surface region of the sample.

[0016] Thus, spectroscopic information is obtained non destructively that can be interpreted to establish the nature and composition of a diffusely scattering sample below a surface layer. The present invention as defined by the methods outlined above effectively implements a form of spatial gating of the Raman signal obtained from the sample to isolate the Raman signal from a sub-surface layer which has a different composition to that of the surface layer. This method is referred to herein as Spatially Offset Raman Spectroscopy (SORS).

[0017] With the present invention for samples having one or more different chemical compositions at differing depths within the sample, the collection of Raman spectra from regions spatially offset, by different amounts, from the point of incidence of the probe laser beam results in a series of spectra (two or more spectra) each spectra including Raman signals emanating from different depths within the sample. The series of spectra taken contain different relative contributions of the Raman signals generated from the sample surface layer and the sample

sub-surface layers. In collecting the data series, as the signal collection point is moved away from the point of incidence of the probe laser beam, the contribution of the surface layer signal diminishes much faster than for signals generated by different compositions at deeper layers within the bulk of the sample. This enables the contribution of deeper, sub-surface layers to be extracted either directly or by applying numerical processing to the collected spectral set for a higher degree of separation (e.g. multivariate data analysis or scaled subtraction of spectra from each other).

[0018] In a preferred embodiment two or more Raman spectra are collected and are analysed using a scaled subtraction, the Raman spectrum collected from or at a distance closest to the point of irradiation being subtracted from the Raman spectrum collected further from the point of irradiation, whereby features of the Raman spectrum for a sub-layer of the sample are identified.

[0019] In a further alternative, where the Raman spectrum for the chemical composition of the surface of the sample is known, the collected Raman spectra are analysed by scaled subtraction of the known Raman spectrum from the Raman spectra of the collected light.

[0020] In an alternative preferred embodiment at least twenty Raman spectra are collected at different distances from the point of irradiation and the plurality of Raman spectra are analysed using multivariate data analysis. Principal component analysis may be used as the multivariate data analysis.

[0021] A preferred feature of the present invention is irradiation of the sample at two or more different wavelengths, where the collected light is a combination of a Raman spectrum and fluorescence, so that the Raman spectrum can be extracted from the collected light.

[0022] At least one of the sample, the collection optics and the point of irradiation may be moved relative to the others to enable the collection of Raman spectra at different distances from the point of irradiation. A movable stage may be provided on which the sample is mounted and the probe beam is arranged to track the movement of the sample whereby the sample is moved relative to fixed collection optics for the collection of scattered light at different distances from the point of irradiation.

[0023] The scattered light may be collected from point regions at different distances from the point of irradiation or the scattered light may be collected from a plurality of substantially parallel lines substantially transverse to the distance as measured from the point of irradiation.

[0024] Alternatively, the probe beam may be supplied using optical fibres and the scattered light may be collected using optical fibres arranged in a plurality of concentric circles around the probe beam optical fibres whereby the scattered light is collected in concentric rings at differing radii from the point of irradiation.

[0025] Ideally, the light probe is at >200 nm and <2000 nm and may be generated by one or more quasi-monochromatic lasers or a diode laser which is tunable, for example with respect to temperature.

[0026] In an alternative aspect embodiments of the invention provide apparatus for selectively measuring Raman spectra generated at different depths within a diffusely-scattering medium, the apparatus comprising: a light source for irradiating a sample with a probe beam; collection optics for collecting light scattered by the sample and passing it to a spectrometer; detection means for detecting light dispersed by the spectrometer, wherein the apparatus is adapted for scattered light to be collected at a plurality of spatial locations on the surface of the sample, each spatial location being at a different distance from the point of irradiation and at least a portion of the light collected at each spatial location being separately spectrally dispersed by the spectrometer to form a plurality of Raman spectra and wherein the apparatus further includes an analyser for identifying features specific to the Raman spectrum of a sub-layer of the sample from the plurality of Raman spectra.

[0027] The apparatus preferably includes a movable stage for relative movement of at least one of the sample, the collection optics and the point of irradiation to enable the collection of Raman spectra at different distances from the point of irradiation. Alternatively, the collection optics may comprise optical fibres arranged in a plurality of concentric circles around the probe beam.

[0028] The light source may consist of one or more quasi-monochromatic lasers or a diode laser which are tunable, for example with-respect to temperature.

[0029] Preferably one or more features specific to the Raman spectrum of the sub-layer region of the sample are identified in the one or more collected Raman spectra and are compared with those obtained from a healthy control specimen.

[0030] Embodiments of the invention will now be described by way of example only and with reference to the accompanying drawings.

Brief Description of the Drawings

[0031]

Figure 1 illustrates principles of the invention, in which illumination by source 10 leads to a Raman scattering 16 in a sub-surface region of sample 14, the Raman photon being received at collector 18;

Figures 2a to 2c illustrate various sample layer arrangements;

Figures 3a to 3c illustrate various entry and collection region arrangements;

Figure 4 shows an arrangement for varying the diameter of an annular collection region using an optical arrangement 50, 54;

Figure 5 illustrates the use of mirrors 60 to enhance the collection of Raman photons;

Figure 6 shows an optical head 70 for coupling to a spectral detector 22;

Figures 7a and 7b show plan details of the optical head and connector of Figure 6;

Figure 8 illustrates schematically analysis apparatus in accordance with the present invention set up to extract Raman spectra generated beneath a surface layer of a sample;

Figure 9 illustrates a point collection geometry for collection of spatially offset Raman spectra in accordance with the present invention;

Figure 10 illustrates a concentric circle collection geometry for collection of spatially offset Raman spectra in accordance with the present invention;

Figure 11 shows a series of Raman spectra for a two layer sample generated at different offsets using the analysis apparatus of the present invention;

Figure 12 illustrates the dependence on offset distance of the absolute intensities of the Raman spectra for the sample of Figure 11;

Figure 13 illustrates the ratio of the Raman spectra of Figure 12 with respect to offset distance;

Figure 14 shows a series of Raman spectra for the same two layer sample scaled to the same height of trans-stilbene bands;

Figure 15 illustrates the PMMA contributions within the individual spectra of Figure 14;

Figure 16 shows, for the same sample, the relative ratio of a trans-stilbene Raman signal in comparison with fluorescence originating from the PMMA layer as a function of the spatial collection offset;

Figure 17 shows the results of a PCA analysis of a series of Raman spectra for the same sample obtained using the analysis apparatus in accordance with the present invention; and

Figure 18 shows the results of a simple subtraction process with respect to the same sample using Raman spectra obtained by the analysis method in accordance with the present invention.

Detailed Description of the Preferred Embodiments

[0032] Referring now to Figure 1 an embodiment of the invention is shown in operation, in schematic cross section. A light source 10, incorporating or supplied by laser 9, is used to irradiate a localised entry region 11 of a surface 12 of a sample 14. The incident radiation from the light source is scattered diffusely through the sample. Some of the radiation may be absorbed by the sample, some may give rise to optical emissions for example by fluorescence, and some re-emerges unchanged through the sample surface 12.

[0033] A small proportion of the photons of the incident radiation are inelastically scattered giving rise to Raman photons, for example as illustrated by Raman event 16. The Raman photons in turn are diffusively scattered through the sample. Some may be absorbed, for example giving rise to fluorescence, but some emerge unchanged through the surface 12 to be collected at collector 18. The likelihood of a Raman photon undergoing a second Raman event is very small.

[0034] The collected light is analysed, for example us-

ing filters or a spectrometer, and a suitable sensor in detector 22, and the determined Raman spectra or spectral features are used further in analyzer 23, which is typically a computer. The detector may use a fourier transform rather than a conventional dispersive spectroscopic technique.

[0035] Typically, most Raman photons will be generated close to the light source 10, where the incident radiation is most intense. These Raman photons can best be detected by collecting light at the light source 10, for example by using optics common with the light source. As distance from the light source increases, however, the intensity of Raman photons originating near the light source falls away more quickly than the intensity of Raman photons originating further away from the light source, especially from deeper within the sample. Preferential sampling of Raman photons from deeper within the sample can therefore be achieved by spacing the location at which light is collected from the location at which the sample is illuminated, and an analysis of how the detected spectral features change with spacing can provide more detailed sub-surface information.

[0036] In Figure 1 Raman event 16 occurs in a sub-surface layer 20. The spacing d between the light source 10 and the collector 18, or equivalently between an entry region 11 and a collection region 19 can be adjusted to select for a particular depth. In preferred embodiments, however, light is collected at a range of two or more spacings d , and an analyzer 23 is used to infer depth dependent characteristics of the sample from the Raman features of the collected and analyzed light for different values of d , which are spectrally analyzed by analyzer 22. One of the spacings could be at, or very close to the entry region.

[0037] The analyzer selects (or rejects) the Raman features for a particular depth or range of depths by combining the Raman features from different spacings. Some techniques for this, including scaled subtraction and PCA are discussed below.

[0038] In Figure 1 the sample 14 displays a non-abrupt boundary between the surface region and sublayer 20. In Figures 2a to 2c some other sample configurations are shown. In Figure 2a there is an abrupt change from surface layer 30 to deep layer 32, and deep layer 32 may be diffusely scattering, or partly or completely opaque, with Raman photons representative of layer 32 being generated at the layer interface. In Figure 2b the surface layer 30 and the deep layer 32 are separated by a further transparent or semi transparent layer 34 which may be, for example, a space filled with a liquid or gas. In Figure 2c a more complex sample is shown, in which graduated or abrupt sublayers 36 and 38 are embedded beneath or within the surface layer 30.

[0039] The incident irradiation and collection of light at a single, at multiple or at a variable spacing can be achieved using a variety of geometries. In Figure 3a there is a single illumination or entry region 40 on the sample surface. Spaced from this illumination region is either a

single collection point or region 42, or multiple regions as indicated by the broken lines. Alternatively the single collection region, or equivalently the illumination region may be moved to provide a variable spacing.

[0040] In Figure 3b the single illumination region 40 is surrounded by an annular collection region 44, or by multiple or a variable radius annular collection region as indicated by the broken lines. Instead of an annular collection region, a broken annulus or multiple separate regions at similar distances from the point of illumination could be used.

[0041] In Figure 3c an annular illumination region 46 and central collection region 48 are used, thereby reducing the localised intensity of incident radiation required to generate a given number of Raman photons. The annulus may be varied in radius or be provided as multiple annuli having a range of radii, and a broken annulus of multiple separate illumination regions distributed at similar distances from the central point of collection may be used.

[0042] Generally, it is beneficial to collect light, or to provide incident radiation at as large a proportion of an entry or collection region as possible. However, in practical embodiments the coverage may be limited. For example, in arranging cylindrical optical fibres in an annulus a coverage of 10% or more may be adequate, but 25% or more would be preferred and 60% or more may be possible.

[0043] In simplistic embodiments a single entry region may be provided by a single optical fibre brought close to the sample surface, and multiple collection regions may be provided by a linear array of collection fibres. Optical fibres may be similarly used to provide annular and other configurations of single and multiple fixed spacings and various mechanical arrangements may be used to provide variable spacings.

[0044] To provide a variable radius entry region or collection region an optical arrangement such as that illustrated in figure 4 may also be used. Optics 50 located between the sample and the collector and/or sample-to-detector distance is adjustable to direct light from different parts of the sample surface onto collector 18 which is concentric with the light source 10. In this arrangement, a lens arrangement (and/or the illumination source and Raman collector detector position) which can be translated in an axial direction 52 by an optics drive 54 directs light from an annular region of varying radius onto the collector, but other configurations are also envisaged.

[0045] A further aspect, which may be used with any of the arrangements discussed above, is illustrated in figure 5. One or more mirror elements 60 are presented to the sample surface. When either incident or Raman radiation emerges from the sample away from the collector 18, these mirror elements redirect the emerging radiation back into the sample. This increases the intensity of incident radiation and so the generation of Raman photons within the sample, and also increases the proportion of Raman photons received at the collector 18.

The mirror elements are preferably absent from the surface adjacent to the light source 10 or entry region, and adjacent to the collection regions.

[0046] In alternative embodiments non-imaging optics, such as those described in Applied Optics vol 35 p 758, may be used to achieve higher collection efficiency by use of a mask placed directly onto the sample, or placed in an image plane if other imaging optics are also used. The mask blocks appropriate areas of the sample to collect signal from a desired spatial offset only. The masking is preferably synchronised with a detector such as a charge coupled device such that sequential readings from the detector relate to masks providing light collected from correspondingly sequential spacings between the illumination and collection regions. The masking could be mechanical and could also be performed between imaging optics and a non-imaging type detector.

[0047] Figure 6 illustrates a practical embodiment of the invention comprising an optical head 70 coupled by an optical fibre bundle 72 to analyser 22. Detail of the optical head 70 is shown in the plan schematic view of figure 7a which is not to scale. A bundle of light source optical fibres 74 terminate in the central region of the head. These light source fibres are embedded in a filler 76 such as epoxy, and surrounded by an annular spacer element 78. Collection optical fibres 80 terminate an annular region surrounding the spacer element, again embedded in a filler, and surrounded by an external casing. This arrangement may be adapted to include the various mirror and optical arrangements discussed above.

[0048] In this particular embodiment each optical fibre has a core of 200 μm diameter and a cladding bringing the fibre thickness to 230 μm . The inner bundle consists of seven light source optical fibres 74, and the outer bundle consists of 26 collection optical fibres 80. The spacer 78 is sized to space the collection fibres 80 about 3 mm from the centre of the head, and the terminations of the collection fibres are distributed approximately evenly in an annulus of constant radius about this centre. The collection fibres should be suitable for carrying out near infra red Raman work, and may be made of silica.

[0049] The illumination and collection optical fibres terminate, about 100cm distant from the optical head, in a connector illustrated schematically in Figure 7b. The connector presents the six illumination and twenty six collection fibres for coupling into the analyzer 22 of Figure 6, which incorporates a light source illumination quasi-monochromatic laser operating at 827nm and a Kaiser Holospec optical analyser.

[0050] A schematic diagram of another spatial gating analysis apparatus for identifying depth specific Raman spectra is shown in Figure 8. The features and variations already described above may be applied here as appropriate, such as the various collection geometries, and vice versa. The apparatus generally comprises a laser 101, Raman detection apparatus 102, 103 and an analyser 104. The probe beam 105 of the apparatus is generated using a quasi-monochromatic laser such as a sin-

gle-line cw argon ion laser operating at 514 nm, (in the case of tissue analysis 827 nm would be preferred to avoid fluorescence background), with 12 mW power which is directed using conventional optics at a sample.

5 The sample has a surface layer 106 and a deeper layer 107 of a different chemical composition to that of the surface layer, and may be mounted on a stage. With this apparatus the laser plasma lines were blocked using a Pellin-Broca prism (not illustrated). The apparatus includes a 1 m focal length lens 108 for weakly focusing the laser beam onto the sample to a spot diameter of 300 μm and at normal incidence. Raman light produced as a result of the irradiation of the sample is collected in backscattering geometry using a 2" diameter collection lens 109 with f-number ~ 1 and is imaged with the lens 109 onto the slit of a spectrometer 102, which is part of the Raman detection apparatus, with a magnification of 15 2.5. A conventional imaging spectrometer 102 (for example a Spex Triplemate™ with f-number 6.3) is preferably used to disperse the Raman light and image the Raman light onto a CCD camera 103. The camera 103 is preferably a liquid nitrogen cooled backilluminated deep depletion CCD camera (for example Andor, DU420-BU2 (250 nm) 1024x255 active pixels). The CCD quantum efficiency of such a camera in the region of Raman spectra is around 65% and has a pixel size of 26x26 μm . The final stage slit width of the 25 spectrometer 102 was set to 120 μm . The CCD was binned vertically across 20 pixels to maintain the spatial selectivity on the collection side.

[0051] The sample 106, 107 was mounted on an x-y-z micropositioning stage 110 which includes a controlled drive (not illustrated) which moves the stage (vertically in Figure 8) together with the final optics to keep the incidence point of the laser beam fixed on the sample with respect to the sample. In this configuration, the Raman detection apparatus 102, 103 always collects back scattered Raman shifted photons from a fixed imaging zone in space and the sample is scanned across this imaging zone whilst the pump beam incidence point remains fixed in its position on the surface of the sample. A filter (not illustrated) may also be used to block any residual elastically scattered probe laser light from reaching the spectrometer 102. The SORS apparatus described above may be deployed using a point collection laterally offset from the point of probe beam incidence (Figure 9). Alternatively, a movable stage or other movement control means may be used for achieving relative movement between one or more of the sample, point of irradiation and the Raman detection apparatus.

[0052] Raman spectra using apparatus similar to that described above were collected for a test sample in which the first layer 106 consisted of a 1 mm optical path cuvette of 1 cm width and - 4 cm height, with 300 μm custom made fused silica front and back windows, filled with PM-MA (poly(methyl methacrylate)) spheres of - 20 μm diameter. The spheres were loosely packed in the cell using mechanical tapping on the cell during filling to elimi-

nate any larger voids. This first layer was followed by a second layer 107 consisting of another cell of 2 mm optical path filled with trans-stilbene fine powder ground using a mortar and pestle. The cuvettes were employed in order to provide a simple method of sample handling and are not an essential feature of the apparatus.

[0053] With the probe laser beam incident on the sample positioned with the first layer 106 uppermost, spatially offset Raman spectra using the SORS method described herein were collected using a basic point collection geometry in which collection is from the points laterally displaced from the probe beam's incidence point (Figure 9). The point of collection geometry as illustrated in Figure 9 represents the simplest implementation of the method of the present invention. On the other hand, the concentric circle geometry illustrated in Figure 10, which does not require the use of an x-y positioning stage, advantageously yields much higher collection efficiency but involves the use of optical fibres to image the individual circles at different heights on the spectrometer slit enabling their imaging after dispersion on the CCD 103 onto separate horizontal strips with the vertical position of the spectra on the CCD corresponding to a given offset collection distance on the sample surface with respect to the probe beam's incidence point. The use of a fiber optic bundle for the collection of Raman spectra is described in an article by Jiaying Ma and Dor Ben-Amotz entitled "Rapid Micro-Raman Imaging using Fiber-Bundle Image Compression" Applied Spectroscopy Vol. 51, No. 12, 1997 the contents of which is incorporated herein by reference.

[0054] It will, of course, be apparent that further alternative collection geometries could be employed whilst still achieving spatially offset Raman spectra collection in accordance with the present invention.

[0055] Additionally, with no sample illumination, an "above the sample" Raman spectrum may be collected which represents background and apparatus noise. This "above the sample" Raman spectrum can then be subtracted from the set of Raman spectra to remove noise from the spectra.

[0056] When taking Raman spectra using the resonance Raman technique, whereby the wavelength of the incident probe beam is tuned to match chromophores of the material or materials being investigated, the Raman signatures may be swamped by fluorescence (luminescence) generated from electronic excitation. For example, fluorescence will be stimulated in room temperature studies of bone, but phosphorescence is more likely in colder samples. Similarly, Raman probing of metallic systems will often stimulate room temperature phosphorescence.

[0057] In such cases the Raman spectra can be recovered using the SORS method at two or more laser wavelengths. This relies upon the fact that the spectral profile of a fluorescent background is not normally dependent on the excitation wavelength whereas the Raman spectrum is dependent on the excitation wave-

length. Hence, spectra collected at the same spatial distance from the point of illumination at two or more different wavelengths of irradiation may be subtracted from each other to give a derivative type plot of where the Raman bands are and this can be mathematically processed to give a truer looking Raman spectrum. This technique for identifying Raman bands is described in an article by S. E. J. Bell, E. S. O. Bourguignon and A. C. Dennis entitled "Subtracted shifted Raman spectroscopy (SSRS) method" Analyst, 1998, 123, 1729-1734. This technique is also referred to as the Shifted Excitation Raman Difference technique (SERD) as described in a paper of the same name by P. Matousek, M. Towrie and A. W. Parker IJ. Raman Spec., 33, 128-242 (2002) the contents of which is incorporated herein by reference.

[0058] The two or more wavelengths of incident irradiation may be generated by means of separate lasers or by means of a single laser, such as a diode laser, the output of which is varied for example through temperature tuning. The difference in wavelength required is generally about half the width of the Raman bands, typically approximately 5-10 cm^{-1} .

[0059] A set of Raman spectra for the test sample described above, measured with a varying degree of spatial offset with respect to the Raman collection point and the point of laser incidence on sample surface is shown in Figure 11. For comparison, the Raman spectra of pure layers measured in separate measurements are also displayed. The top spectrum in Figure 11 is that of pure trans-stilbene and the bottom spectra that of pure PMMA. The spectrum measured with the zero offset (0 mm) represents the Raman spectrum one would typically obtain using a conventional Raman instrument. It is evident that it contains an appreciable contribution from both the top and bottom layers of the sample and that the contribution of the top layer gradually decreases with offset distance in the spatially offset spectra. For real applications, where a pure spectrum of the bottom layer needs to be recovered, the top layer signal might represent an unacceptable distortion to the Raman signal of a lower layer. The gradual separation between the two signals is clearly accomplished using the SORS approach as the lateral offset between the Raman collection point and the point of probe beam incidence is increased and is clearly observable from the illustrated data set. At a distance of >2 mm (third spectra down in Figure 11) an order of magnitude improvement in the ratio of the lower over the top layers Raman signals is achieved.

[0060] Figure 12 shows the dependence of the absolute Raman intensities of the individual spectra on the spatial offset. The data was obtained by numerical fitting of two intense trans-stilbene bands at 1575, 1595, 1632 and 1641 cm^{-1} and bands at around 809, 1455, and 1728 cm^{-1} for PMMA. The plot clearly demonstrate that as the Raman collection point is moved sideways from the probe illumination zone, i.e. the lateral offset is increased, the Raman signal from the bottom layer diminishes much more slowly than that from the top layer. This results in

the overall relative Raman intensity ratio of the bottom over the top layer improving with increasing spatial offset as shown in Figure 13.

[0061] To quantify the contrast improvement achieved using the method and apparatus of the present invention with respect to the test sample described above, a Raman spectrum with a longer acquisition time (1000s) at an offset of 3.5 mm was acquired. Figure 14 shows this spectrum along with a Raman spectrum acquired with zero offset scaled to the same height of trans-stilbene bands. By subtracting the pure trans-stilbene spectrum from these spectra we obtained the PMMA contributions within the individual spectra (see Fig. 15). By fitting these we established that the contrast of the lower layer had been improved by a factor of 15 by rejecting the top layer spectral component. Another striking observation is that the signal-to-noise obtained using this spatial gating approach is good in comparison to alternative approaches.

[0062] The total attenuation of the Raman trans-stilbene signal by the 1 mm PMMA layer was measured with the zero offset to be around 80. This loss of signal through the diffusion process, inevitably present also in conventional Raman spectroscopy, can be, however, effectively offset through further refinements in the collection efficiency: for example by adopting the circular collection geometry shown in Figure 10, or by using a lower f-number and a higher throughput spectrograph.

[0063] Figure 16 demonstrates another useful feature of the spatial gating analysis apparatus and method of the present invention. The analysis apparatus is capable of suppressing fluorescence in the lower layer Raman spectrum if it originates from the top layer. The plot shown in Figure 16 gives the relative ratio of the trans-stilbene Raman signal in comparison with the fluorescence originating from the PMMA layer as well as the fluorescence absolute intensity as a function of the spatial collection offset. The trans-stilbene Raman intensity relative to fluorescence intensity is improved by a factor of approx. 2 with the introduction of a 2.5 mm displacement.

[0064] In a situation where a larger separation of the data obtained from surface and sub-surface layers is required than that achievable directly within the raw spectra, by offsetting the collection and probe launch points a multivariate data analysis procedure may be deployed using the analyser 104 of Figure 8. The data collected by SORS is particularly amenable to multivariate data analysis because for this approach to be applicable, the set of Raman spectra measured at various offsets is still required. To achieve an effective numerical decomposition the number of spectra within the set should ideally be at least an order of magnitude higher than the number of layers present in the sample. To demonstrate this a multivariate analysis of the form of principal component analysis (PCA) was employed.

[0065] Approximately twenty Raman spectra acquired on the PMMA and trans-stilbene two-layer system represented in Figure 8 and produced using the SORS method and apparatus described herein were imported into

Matlab™ R11 (The Mathworks Inc., Natick, MA) and processed with both built in and locally written scripts. The ten largest eigenvectors generated after performing a singular value decomposition on the original data set were included in the PCA rotation. The pure spectra of PMMA and trans-stilbene were not included in this dataset and no baseline correction was performed.

[0066] Multivariate data reduction techniques are advantageous when a complete separation of the spectral features of the surface and sub-surface layers is required. These data reduction techniques also provide a means of separating spectral features from layers that may have a moderate to high degree of spectral overlap or where contributions of individual components to spectral bands envelopes may not be known because spectra of the pure components may not be obtainable or known.

[0067] The recovered factors from the multivariate analysis are shown in Figure 17. The procedure cleanly decomposed the Raman spectra collected in this way into the pure spectra of the two individual layers, i.e. a PMMA (top layer) and a trans-stilbene (bottom layer). A factor for pure trans-stilbene was recovered by targeting the ca. 1595 cm⁻¹ band (pixel 730) and a factor for pure PMMA was recovered by targeting the ca. 809 cm⁻¹ band (pixel 80). The luminescence background factor was constructed from one of the original input spectra. This factor was generated using an iterative polynomial fitting algorithm (Lieber CA and Mahadevan-Jansen A 2003) typically used for baseline correction. In this case 100 fitting cycles using a third order polynomial were used to generate the baseline. This baseline was used as a factor representing the luminescence background. These three factors were then used to reconstruct the dataset with less than 3% error.

[0068] Although in the above example twenty separate Raman spectra were collected, where a scaled subtraction of individual Raman spectra is possible, as few as two or three spectra are required. Even with multivariate data analysis, although it is preferred to perform the analysis on at least a factor more than the number of components to be identified, such analysis can often be successfully performed using smaller data sets of, for example, around ten spectra.

[0069] The following is the inventors' current theory for explaining the efficacy of the analysis method and apparatus described herein. This theory is supported by detailed Monte Carlo scattering modelling studies also carried out by the inventors, which yield results in very good agreement with experiment. The variation in the relative content of Raman signals from different layers as the collection point is spatial offset originates from the random properties of the photon migration effect. The migrating photons in essence undergo a 'random walk' within the medium and the photon direction is randomised every transport length along the propagation distance. When a Raman signal is collected from the surface of a sample at the point where the probe beam is incident, the spectrum contains a relatively large signal contribu-

tion from the top layer due to the probe photon density being highest at the point of sample exposure. With increasing sample depth the probe intensity fast diminishes as the photon intensity is progressively diluted through the photon diffusion process. Moreover, Raman light generated at deeper layers of the sample is scattered as it propagates back to the surface and is subject to the same diffusion. This therefore leads to further dilution of the intensity of Raman spectra generated at deeper sample layers. This effect results in a substantially larger proportion of Raman photons generated at the sample surface being collected than those generated at deeper sample layers when a signal is collected from the surface of a sample at the point where the probe beam is incident, in comparison to the signal that would be collected for an optically transparent media probed in the same geometry.

[0070] However, when Raman light is collected from a point laterally offset from the point of probe beam incidence, the probe light intensity within the sample is becoming more equally distributed along its depth. This is because the incident light first had to propagate sideways through the sample from the probe incidence point to the collection area and was on its way randomised through photon diffusion. Consequently, the scattered Raman signal collected at a position offset from the probe incidence point contains a higher proportion of the deeper layer signal than that in the spectrum collected from the probe beam incidence point.

[0071] The described spatial gating analysis apparatus and method thus offers an extremely powerful, yet simple means for extracting pure Raman signals from individual layers within diffusely scattering media. The probed sample depths can be well in excess of the transport length, which sets a depth limit on the conventional confocal Raman microscopy. In the above example, the transport length of the medium was estimated to be 200 μm . Importantly, the apparatus and method can be used 'blind', i.e. without any prior knowledge of the chemical constituents of individual layers. The technique has thus ideal prerequisites for sensitive sub-surface, non-destructive probing of diffusely scattering materials in both industrial and medical applications.

[0072] In situations where a sample is known to consist of only two layers of different composition (if this is not known then this information can be obtained directly from pure PCA) the method and apparatus can be used to extract the pure signals of individual layers without the involvement of multivariate data analysis techniques. This is possible where the two spectra of the two layers each include an identifiable band or bands that do not overlap. In this situation a simple scaled subtraction can be used to separate the spectra of each of the individual layers from each other. In this process one Raman component is eliminated by a scaled subtraction of two spectra measured with two different spatial offsets cancelling out one or other spectral component in the process. The results of this simple extraction procedure are shown in

Figure 18. The spectra used in the analysis were measured with a zero and a 2 mm offset. The result is clearly satisfactory, although the applicability requires the above conditions to be satisfied. In contrast, the PCA analysis described above can be used in circumstances where there is no knowledge of the compositions of the different layers of a sample.

[0073] Thus, it will be apparent that it is not in all cases essential for a complete Raman spectrum to be generated with the present invention. Where there is some knowledge of the materials involved or the compositions to be detected, detection of individual Raman spectral features using, for example, one or more band pass filters is also encompassed by the SORS method and apparatus described herein.

[0074] The exact degree of the 'suppression' or separation of two layers in general situations depends on a variety of parameters. These parameters include the thickness of the top layer, that of the underlying matrix, the probe beam diameter, the exact collection geometry, the wavelength of the probe light used and the transport length of the medium. For non-invasive sub-surface probing, as a rule of thumb, it is believed that the ideal offset should be on the scale of the thickness or several thicknesses of the overlying medium. Also, for the technique to be effective the beam diameter should be smaller than the thickness of the top layer. In general terms the thinner the top layer is and the thicker the underlying matrix is favours a better spectral separation of the two components.

[0075] The use of probe light of particular wavelengths is not critical to this invention. The choice of probe wavelength is essentially a trade off between depth penetration, which improves with longer wavelength, and detector quantum efficiency, which is higher at shorter wavelengths. As mentioned earlier, the detector 3 used herein is a backilluminated deep depletion CCD detector based on silicon technology. This detector is selected as it has the best sensitivity and signal-to-noise ratio of those that are currently available, but alternatives can be used. Longer wavelengths avoid exciting H_2O modes in Raman spectra, but the cut-off limit for Si detection is 1.1 μm . InGaAs detectors can be used at longer wavelengths, but these have currently reduced sensitivity.

[0076] With the method and apparatus of the present invention, substantially pure Raman spectra can be retrieved from depths well in excess of those accessible with conventional confocal microscopy. Moreover, the present invention has the advantage that it is compatible with the use of cw lasers beams and is suited to remote monitoring in both industrial and medical applications. Thus the method and apparatus are well suited to not only biomedical applications, where monitoring sub-surface tissue layers normally would require destroying surface tissue, but also many industrial analytical applications such as catalysts, food, and polymers research applications. The present invention may be used to detect contamination of food during manufacture or the dele-

rious breakdown of food in storage as well as the stability of stored pharmaceuticals in all cases without any contact with the sample.

Claims

1. A method of measuring sub-surface Raman scattering through a diffusely scattering sample (14), the method comprising steps of:

(a) supplying incident radiation at one or more entry regions (11) on a surface (12) of the sample;

(b) collecting light scattered within the sample, from one or more collection regions (19) on the surface, at a plurality of spacings from the one or more entry regions; and

(c) detecting, in the collected light, for each spacing, one or more Raman features spectrally related to the incident radiation,

characterised in that the method further comprises:

(d) deriving, from changes in intensities of the one or more Raman features between the different spacings, one or more characteristics of a sub-surface region (20) of the sample (14), by combining the Raman features from different spacings to select the Raman features for a particular depth or range of depths.

2. The method of claim 1 wherein step (c) comprises, for each spacing, spectrally dispersing the collected light to form a Raman spectrum.

3. The method of claim 2 wherein step (d) comprises analysing the plurality of Raman spectra to extract information on the Raman spectrum of a sub-surface region of the sample.

4. The method of claim 1, 2 or 3 wherein incident radiation is supplied to one entry region by irradiating the sample with a light probe at a point of irradiation, and the step of collecting comprises collecting light at a plurality of collection region spatial locations on the surface of the sample, each spatial location being at a different distance from the point of irradiation.

5. The method of claim 4 wherein the step of deriving includes associating the Raman features from different spacings with different depths or distributions of depth within the sample (14).

6. The method of any preceding claim wherein the step of collection comprises collecting light from a plurality of collection regions spaced by different distances from an entry region.

7. The method of any preceding claim wherein one or more collection regions surround an entry region (11),

- 5 8. The method of claim 7 wherein each collection region is an annulus (44), and for each annulus, light is collected from at least 10%, and more preferably at least 25% of the surface area of the annulus (44).

- 10 9. The method of either of claims 7 or 8 wherein the scattered light is collected by a plurality of collection optical fibres distributed around one or more illumination optical fibres used to supply the incident radiation to the entry region.

- 15 10. The method of any of claims 1 to 6 wherein one or more entry regions surround a collection region (48).

- 20 11. The method of any preceding claim further comprising adjusting collection optics (18) disposed in the path of the collected light to adjust the distance between a collection region (19) and an entry region (11).

- 25 12. The method of any preceding claim further comprising disposing one or more mirror elements (60) adjacent to the sample surface outside the collection regions to reflect light back into the sample.

- 30 13. A method of measuring a sub-surface Raman spectrum of a diffusely-scattering sample as set out in any preceding claim, the method comprising the steps of:

35 a) irradiating the sample with a light probe (105);
b) collecting light scattered by the sample (106, 107); and

c) spectrally separating at least a portion of the collected light to detect one or more Raman spectral features,

40 wherein light scattered by the sample is collected from a plurality of spatial locations on the surface of the sample, each spatial location being at a different distance from the point of irradiation, at least a portion of the light collected at each spatial location being separately spectrally dispersed to form a plurality of Raman spectra and wherein the method further includes the step of:

45 d) analysing the plurality of Raman spectra to extract information on the Raman spectrum of a sub-surface region of the sample.

- 50 14. A method as claimed in any preceding claim, wherein at least two Raman spectra are collected and are analysed using a scaled subtraction, the Raman spectrum collected at a distance closest to the point of irradiation being subtracted from the Raman spec-

- trum collected further from the point of irradiation, whereby features of the Raman spectrum for a sub-layer of the sample are identified.
15. A method as claimed in any of claims 1 to 13, wherein the Raman spectrum for the chemical composition of the surface of the sample is known and the Raman spectra are analysed by scaled subtraction of the known Raman spectrum from the Raman spectra of the collected light.
16. A method as claimed in any of claims 1 to 13, wherein the plurality of Raman spectra are analysed using multivariate data analysis.
17. A method as claimed in claim 16, wherein the plurality of Raman spectra are analysed using principal component analysis.
18. A method as claimed in either of claims 16 or 17, wherein at least ten Raman spectra are collected at different distances from the point of irradiation.
19. A method as claimed in any one of the preceding claims, wherein the sample is irradiated at two or more different wavelengths and the collected light is a combination of a Raman spectrum and fluorescence and wherein the method comprises the further step of extracting the Raman spectrum from the collected light.
20. A method as claimed in any one of the preceding claims, wherein at least one of the sample, the collection optics, and the point or region of irradiation is moved relative to the others to enable the collection of Raman spectra at different distances from the point of irradiation,
21. A method as claimed in claim 20, wherein a movable stage is provided on which the sample is mounted and the probe beam is arranged to track the movement of the sample whereby the sample is moved relative to fixed collection optics for the collection of scattered light at different distances from the point of irradiation.
22. A method as claimed in claim 21, wherein the scattered light is collected from point regions at different distances from the point of irradiation.
23. A method as claimed in claim 21, wherein the scattered light is collected from a plurality of substantially parallel lines substantially transverse to the distance as measured from the point of irradiation.
24. A method as claimed in any one of claims 13 to 20, wherein the probe beam is supplied using optical fibres and the scattered light is collected using optical fibres arranged in a plurality of concentric circles around the probe beam optical fibres whereby the scattered light is collected in concentric rings at differing radii from the point of irradiation.
25. A method as claimed in any one of the preceding claims, wherein the collected light is spectrally dispersed using a spectrometer in combination with a CCD camera (103).
26. A method as claimed in any one of the preceding claims, wherein the light probe or incident radiation is generated using a continuous wave laser (101).
27. A method as claimed in claim 20, wherein the light probe comprises two or more separate wavelengths and is generated by one or more lasers.
28. A method as claimed in claim 27, wherein the light probe is generated by a single tunable laser.
29. A method as claimed in claim 27, wherein the two or more separate wavelengths of the light probe are generated by two or more respective lasers.
30. A method as claimed in any of claims 26 to 29, wherein the light probe provides radiation at a wavelength of >200 nm and <2000 nm.
31. Apparatus for measuring sub-surface Raman scattering through a diffusively scattering sample (14), comprising:
- a light source (9) arranged to supply incident radiation at one or more entry regions on a surface of the sample;
- a collector (18) arranged to collect light scattered within the sample, from one or more collection regions (19) on the surface, at a plurality of spacings from the one or more entry regions (11);
- a detector (22) arranged to detect, for each spacing, one or more Raman features spectrally related to the incident radiation,
- characterised in that** the apparatus further comprises:
- an analyzer (23) adapted to derive, from the intensities of the Raman features at the different spacings, one or more characteristics of a sub-surface region (20) of the sample, by combining the Raman features from said plurality of spacings to select the features for a particular depth or range of depths.
32. The apparatus of claim 31 adapted to supply incident radiation to one entry region by irradiating the sample with a light probe at a point of irradiation, and to collect light at a plurality of collection region spatial lo-

cations on the surface of the sample, each spatial location being at a different distance from the point of irradiation.

33. The apparatus of either of claims 31 to 32, wherein the analyzer is adapted to identify features specific to the Raman spectrum of a sub-layer of the sample from the Raman features. 5
34. The apparatus of any of claims 31 to 33 wherein the detector (22) comprises a spectrometer arranged to spectrally disperse the collected light to separate out said Raman features for each spacing. 10
35. The apparatus of any of claims 31 to 33 wherein the detector (22) comprises one or more filters arranged to selectively transmit said Raman features for each spacing. 15
36. The apparatus of any of claims 31 to 35 wherein either the entry region or the collection region is an annular region. 20
37. The apparatus of claim 36 further comprising an optics arrangement (50) adapted to controllably adjust the diameter of the annular region. 25
38. The apparatus of any of claims 31 to 36 further comprising a masking device arranged to controllably adjust the spacing between the entry region and the collection region. 30
39. The apparatus of any of claim 31 to 38 further comprising one or more mirror elements (60) disposed adjacent to the sample surface outside the one or more collection and entry regions so as to reflect light back into the sample. 35
40. Apparatus for selectively measuring Raman spectra generated at different depths within a diffusely-scattering medium, as set out in any of claims 31 to 39, the apparatus comprising: 40

a light source (101) for irradiating a sample with a probe beam; 45

collection optics (109) for collecting light scattered by the sample and passing it to a spectrometer (102);

detection means (103) for detecting light dispersed by the spectrometer, 50

wherein the apparatus is adapted for scattered light to be collected at a plurality of spatial locations on the surface of the sample, each spatial location being at a different distance from the point of irradiation and at least a portion of the light collected at each spatial location being separately spectrally dispersed by the spectrometer to form a plurality of Raman spectra and wherein 55

the apparatus further includes an analyser (104) for identifying features specific to the Raman spectrum of a sub-layer of the sample from the plurality of Raman spectra.

41. Apparatus as claimed in any of claims 31 to 40, wherein the analyser (104) is adapted to perform a scaled subtraction between Raman spectra.
42. Apparatus as claimed in any of claims 31 to 40, wherein the analyser (104) is adapted to perform multivariate data analysis on the Raman spectra.
43. Apparatus as claimed in claim 42, wherein the analyser (104) is adapted to perform principal component analysis on the Raman spectra.
44. Apparatus as claimed in any one of claims 31 to 42, further comprising a movable stage for relative movement of at least one of the sample, the collection optics and the point of irradiation to enable the collection of Raman spectra at different distances from the point of irradiation.
45. Apparatus as claimed in claim 44, wherein the movable stage is a movable sample stage and wherein means are provided for tracking the probe beam with respect to movement of the sample whereby the sample may be moved relative to the fixed collection optics to enable scattered light to be collected at a plurality of distances from the point of irradiation.
46. Apparatus as claimed in any one of claims 31 to 42, wherein the collection optics comprises optical fibres arranged in a plurality of concentric circles around the probe beam. 35
47. Apparatus as claimed in any one of claims 31 to 45, wherein the light source (101) is a continuous wave laser. 40
48. Apparatus as claimed in any one of claims 31 to 46, wherein the detection means comprises a CCD camera. 45
49. The method or apparatus of any preceding claim wherein at one of the plurality of spacings the entry and collection regions are at the same place or substantially overlap. 50
50. The method or apparatus of any of claims 1 to 48 wherein the plurality of entry and collection regions are non overlapping. 55

Patentansprüche

1. Verfahren zum Messen von Unter-Oberflächen-Ra-

man-Streuung durch eine diffus streuende Probe (14), wobei das Verfahren die Schritte umfasst:

- (a) Zuführen einfallender Strahlung in einem oder mehreren Eintrittsbereichen (11) auf einer Oberfläche (12) der Probe;
- (b) Sammeln von innerhalb der Probe gestreutem Licht aus einem oder mehreren Sammelbereichen (19) auf der Oberfläche in einer Mehrzahl von Abständen von dem einen oder den mehreren Eintrittsbereichen; und
- (c) Detektieren eines oder mehrerer mit der einfallenden Strahlung spektral in Beziehung stehender Raman-Merkmale für jeden Abstand in dem gesammelten Licht,
dadurch gekennzeichnet, dass das Verfahren ferner umfasst:
- (d) Ableiten einer oder mehrerer Eigenschaften eines Unter-Oberflächen-Bereichs (20) der Probe (14) aus Änderungen in Intensitäten des einen oder der mehreren Raman-Merkmale zwischen den unterschiedlichen Abständen durch Kombinieren der Raman-Merkmale aus unterschiedlichen Abständen, um die Raman-Merkmale für eine bestimmte Tiefe oder einen Tiefenbereich auszuwählen.
2. Verfahren nach Anspruch 1, wobei Schritt (c) für jeden Abstand spektrales Auflösen des gesammelten Lichts umfasst, um ein Raman-Spektrum zu bilden.
3. Verfahren nach Anspruch 2, wobei Schritt (d) Analysieren der Mehrzahl von Raman-Spektren umfasst, um Informationen über das Raman-Spektrum eines Unter-Oberflächen-Bereichs der Probe zu extrahieren.
4. Verfahren nach Anspruch 1, 2 oder 3, wobei einfallende Strahlung einem Eintrittsbereich durch Bestrahlen der Probe mit einer Lichtsonde an einem Bestrahlungspunkt zugeführt wird und der Sammelschritt Lichtsammlung an einer Mehrzahl von räumlichen Sammelbereichsstellen auf der Oberfläche der Probe umfasst, wobei jede räumliche Stelle in einer unterschiedlichen Entfernung von dem Bestrahlungspunkt ist.
5. Verfahren nach Anspruch 4, wobei der Ableitungsschritt Zuordnen der Raman-Merkmale von unterschiedlichen Abständen mit unterschiedlichen Tiefen oder Tiefenverteilungen innerhalb der Probe (14) umfasst.
6. Verfahren nach einem der vorhergehenden Ansprüche, wobei der Sammelschritt Lichtsammlung aus einer Mehrzahl von Sammelbereichen umfasst, die mit unterschiedlichen Entfernungen von einem Eintrittsbereich beabstandet sind.

7. Verfahren nach einem der vorangehenden Ansprüche, wobei ein oder mehrere Sammelbereiche einen Eintrittsbereich (11) umgeben.
8. Verfahren nach Anspruch 7, wobei jeder Sammelbereich ein Kreisring (44) ist und für jeden Kreisring Licht von wenigstens 10%, vorzugsweise wenigstens 25% der Fläche des Kreisrings (44) gesammelt wird.
9. Verfahren nach Anspruch 7 oder 8, wobei das gestreute Licht von einer Mehrzahl von optischen Sammel Fasern gesammelt wird, die um eine oder mehrere optische Beleuchtungsfasern verteilt sind, die dazu verwendet werden, die einfallende Strahlung dem Eintrittsbereich zuzuführen.
10. Verfahren nach einem der Ansprüche 1 bis 6, wobei ein oder mehrere Eintrittsbereiche einen Sammelbereich (48) umgeben.
11. Verfahren nach einem der vorhergehenden Ansprüche, ferner umfassend Einstellen einer Sammeloptik (18), die in dem Pfad des gesammelten Lichts angeordnet ist, um die Entfernung zwischen einem Sammelbereich (19) und einem Eintrittsbereich (11) einzustellen.
12. Verfahren nach einem der vorhergehenden Ansprüche, ferner umfassend Anordnen eines oder mehrerer Spiegelelemente (60) neben der Probenoberfläche außerhalb der Sammelbereiche, um Licht zurück in die Probe zu reflektieren.
13. Verfahren zum Messen eines Unter-Oberflächen-Raman-Spektrums einer diffus streuenden Probe nach einem der vorhergehenden Ansprüche, wobei das Verfahren die Schritte umfasst:
- (a) Bestrahlen der Probe mit einer Lichtsonde (105);
- (b) Sammeln von von der Probe (106, 107) gestreutem Licht; und
- (c) spektrales Trennen wenigstens eines Teils des gesammelten Lichts, um ein oder mehrere spektrale Raman-Merkmale zu detektieren, wobei von der Probe gestreutes Licht von einer Mehrzahl von räumlichen Stellen auf der Oberfläche der Probe gesammelt wird, wobei jede räumliche Stelle in einer unterschiedlichen Entfernung von dem Bestrahlungspunkt ist, wenigstens ein Teil des an jeder räumlichen Stelle gesammelten Lichts gesondert spektral zerlegt wird, um eine Mehrzahl von Raman-Spektren zu bilden und wobei das Verfahren ferner den Schritt umfasst:
- (d) Analysieren der Mehrzahl von Raman-Spektren, um Informationen über das Raman-Spek-

- trum eines Unter-Oberflächen-Bereichs der Probe zu extrahieren.
- 14.** Verfahren nach einem der vorhergehenden Ansprüche, wobei wenigstens zwei Raman-Spektren gesammelt werden und mittels einer skalierten Subtraktion analysiert werden, wobei das Raman-Spektrum, das in einer Entfernung, welche dem Bestrahlungspunkt am nächsten ist, gesammelt wird, von dem Raman-Spektrum subtrahiert wird, das ferner von dem Bestrahlungspunkt gesammelt wird, wobei Merkmale des Raman-Spektrums für eine Unterschicht der Probe identifiziert werden. 5
- 15.** Verfahren nach einem der Ansprüche 1 bis 13, wobei das Raman-Spektrum für die chemische Zusammensetzung der Oberfläche der Probe bekannt ist und die Raman-Spektren durch skalierte Subtraktion des bekannten Raman-Spektrums von den Raman-Spektren des gesammelten Lichts analysiert werden. 10
- 16.** Verfahren nach einem der Ansprüche 1 bis 13, wobei die Mehrzahl von Raman-Spektren mittels multivariater Datenanalyse analysiert wird. 20
- 17.** Verfahren nach Anspruch 16, wobei die Mehrzahl von Raman-Spektren mittels Hauptkomponentenanalyse analysiert wird. 25
- 18.** Verfahren nach Anspruch 16 oder 17, wobei wenigstens zehn Raman-Spektren in unterschiedlichen Entfernungen von dem Bestrahlungspunkt gesammelt werden. 30
- 19.** Verfahren nach einem der vorhergehenden Ansprüche, wobei die Probe mit zwei oder mehreren verschiedenen Wellenlängen bestrahlt wird und das gesammelte Licht eine Kombination aus einem Raman-Spektrum und Fluoreszenz ist und wobei das Verfahren den weiteren Schritt des Extrahierens des Raman-Spektrums aus dem gesammelten Licht umfasst. 35
- 20.** Verfahren nach einem der vorhergehenden Ansprüche, wobei wenigstens eines aus der Probe, der Sammeloptik und dem Bestrahlungspunkt oder -bereich relativ zu den anderen bewegt wird, um die Sammlung von Raman-Spektren in unterschiedlichen Entfernungen von dem Bestrahlungspunkt zu ermöglichen. 40
- 21.** Verfahren nach Anspruch 20, wobei ein bewegliches Gestell bereitgestellt wird, auf welchem die Probe montiert wird, und der Sondenstrahl dazu eingerichtet ist, der Bewegung der Probe zu folgen, wobei die Probe relativ zu einer festen Sammeloptik bewegt wird zum Sammeln von gestreutem Licht in unterschiedlichen Entfernungen von dem Bestrahlungspunkt. 45
- 22.** Verfahren nach Anspruch 21, wobei das gestreute Licht von Punktbereichen in unterschiedlichen Entfernungen von dem Bestrahlungspunkt gesammelt wird. 50
- 23.** Verfahren nach Anspruch 21, wobei das gestreute Licht von einer Mehrzahl von im Wesentlichen parallelen Linien gesammelt wird, die im Wesentlichen quer zu der von dem Bestrahlungspunkt gemessenen Entfernung sind. 55
- 24.** Verfahren nach einem der Ansprüche 13 bis 20, wobei der Sondenstrahl mittels optischer Fasern zugeführt wird und das gestreute Licht mittels optischer Fasern gesammelt wird, die in einer Mehrzahl von konzentrischen Kreisen um die optischen Sondenstrahlfasern angeordnet sind, wobei das gestreute Licht in konzentrischen Ringen unterschiedlicher Radien von dem Bestrahlungspunkt gesammelt wird. 60
- 25.** Verfahren nach einem der vorangehenden Ansprüche, wobei das gesammelte Licht mittels eines Spektrometers in Verbindung mit einer CCD-Kamera (103) spektral zerlegt wird. 65
- 26.** Verfahren nach einem der vorangehenden Ansprüche, wobei die Lichtsonde oder die einfallende Strahlung mittels eines Dauerstrich-Lasers (101) erzeugt wird. 70
- 27.** Verfahren nach Anspruch 20, wobei die Lichtsonde zwei oder mehrere separate Wellenlängen umfasst und von einem oder mehreren Lasern erzeugt wird. 75
- 28.** Verfahren nach Anspruch 27, wobei die Lichtsonde von einem einzigen durchstimmbaren Laser erzeugt wird. 80
- 29.** Verfahren nach Anspruch 27, wobei die zwei oder mehreren separaten Wellenlängen der Lichtsonde von zwei oder mehreren entsprechenden Lasern erzeugt werden. 85
- 30.** Verfahren nach einem der Ansprüche 26 bis 29, wobei die Lichtsonde Strahlung einer Wellenlänge von >200 nm und <2000 nm bereitstellt. 90
- 31.** Vorrichtung zum Messen von Unter-Oberflächen-Raman-Streuung durch eine diffus streuende Probe (14), umfassend:
eine Lichtquelle (9), die dazu eingerichtet ist, einfallende Strahlung in einem oder mehreren Eintrittsbereichen auf einer Oberfläche der Pro-

- be zuzuführen;
einen Sammler (18), der dazu eingerichtet ist, innerhalb der Probe gestreutes Licht von einem oder mehreren Sammelbereichen (19) auf der Oberfläche in einer Mehrzahl von Abständen von dem einen oder den mehreren Eintrittsbereichen (11) zu sammeln;
einen Detektor (22), der dazu eingerichtet ist, für jeden Abstand ein oder mehrere mit der einfallenden Strahlung spektral in Beziehung stehender Raman-Merkmale zu detektieren,
dadurch gekennzeichnet, dass die Vorrichtung ferner umfasst:
- einen Analysator (23), der dazu angepasst ist, aus den Intensitäten der Raman-Merkmale in den unterschiedlichen Abständen eine oder mehrere Eigenschaften eines Unter-Oberflächen-Bereichs (20) der Probe durch Kombinieren der Raman-Merkmale aus der Mehrzahl von Abständen abzuleiten, um die Merkmale für eine bestimmte Tiefe oder einen bestimmten Tiefenbereich auszuwählen.
32. Vorrichtung nach Anspruch 31, welche dazu angepasst ist, einem Eintrittsbereich einfallende Strahlung zuzuführen durch Bestrahlen der Probe mit einer Lichtsonde an einem Bestrahlungspunkt und Licht an einer Mehrzahl von räumlichen Sammelbereichsstellen auf der Oberfläche der Probe zu sammeln, wobei jede räumliche Stelle in einem unterschiedlichen Abstand von dem Bestrahlungspunkt ist.
33. Vorrichtung nach einem der Ansprüche 31 bis 32, wobei der Analysator dazu angepasst ist, für das Raman-Spektrum einer Unterschicht der Probe spezifische Merkmale aus den Raman-Merkmalen zu identifizieren.
34. Vorrichtung nach einem der Ansprüche 31 bis 33, wobei der Detektor (22) ein Spektrometer umfasst, das dazu eingerichtet ist, das gesammelte Licht spektral zu zerlegen, um die Raman-Merkmale für jeden Abstand auszusondern.
35. Vorrichtung nach einem der Ansprüche 31 bis 33, wobei der Detektor (22) ein oder mehrere Filter umfasst, die dazu eingerichtet sind, die Raman-Merkmale für jeden Abstand selektiv zu transmittieren.
36. Vorrichtung nach einem der Ansprüche 31 bis 35, wobei entweder der Eintrittsbereich oder der Sammelbereich ein ringförmiger Bereich ist.
37. Vorrichtung nach Anspruch 36, ferner umfassend eine Optikanordnung (50), die dazu eingerichtet ist, den Durchmesser des ringförmigen Bereichs regelbar/steuerbar einzustellen.
38. Vorrichtung nach einem der Ansprüche 31 bis 36, ferner umfassend eine Abdeckeinrichtung, die dazu eingerichtet ist, den Abstand zwischen dem Eintrittsbereich und dem Sammelbereich regelbar/steuerbar einzustellen.
39. Vorrichtung nach einem der Ansprüche 31 bis 38, ferner umfassend ein oder mehrere Spiegelemente (60), die neben der Probenoberfläche außerhalb des einen oder der mehreren Sammel- und Eintrittsbereiche angeordnet sind, um Licht zurück in die Probe zu reflektieren.
40. Vorrichtung zum selektiven Messen von Raman-Spektren, die in unterschiedlichen Tiefen innerhalb eines diffus streuenden Mediums erzeugt werden, nach einem der Ansprüche 31 bis 39, wobei die Vorrichtung umfasst:
- eine Lichtquelle (101) zum Bestrahlen einer Probe mit einem Sondenstrahl;
eine Sammeloptik (109) zum Sammeln von von der Probe gestreutem Licht und Weiterleiten des Lichts zu einem Spektrometer (102);
Detektionsmittel (103) zum Detektieren von von dem Spektrometer zerlegtem Licht,
wobei die Vorrichtung dazu angepasst ist, gestreutes Licht an einer Mehrzahl von räumlichen Stellen auf der Probenoberfläche zu sammeln, wobei jede räumliche Stelle in einem unterschiedlichen Abstand vom Bestrahlungspunkt ist und wobei wenigstens ein Teil des an jeder räumlichen Stelle gesammelten Lichts durch das Spektrometer gesondert spektral zerlegt wird, um eine Mehrzahl von Raman-Spektren zu bilden und wobei die Vorrichtung ferner einen Analysator (104) umfasst, um für das Raman-Spektrum einer Unterschicht der Probe spezifische Merkmale aus der Mehrzahl von Raman-Spektren zu identifizieren.
41. Vorrichtung nach einem der Ansprüche 31 bis 40, wobei der Analysator (104) dazu angepasst ist, eine skalierte Subtraktion zwischen Raman-Spektren durchzuführen.
42. Vorrichtung nach einem der Ansprüche 31 bis 40, wobei der Analysator (104) dazu angepasst ist, multivariate Datenanalyse an den Raman-Spektren durchzuführen.
43. Vorrichtung nach Anspruch 42, wobei der Analysator (104) dazu angepasst ist, eine Hauptkomponentenanalyse an den Raman-Spektren durchzuführen.

44. Vorrichtung nach einem der Ansprüche 31 bis 42, ferner umfassend ein bewegliches Gestell zur relativen Bewegung wenigstens eines aus der Probe, der Sammeloptik und dem Bestrahlungspunkt, um die Sammlung von Raman-Spektren in unterschiedlichen Entfernungen von dem Bestrahlungspunkt zu ermöglichen. 5
45. Vorrichtung nach Anspruch 44, wobei das bewegliche Gestell ein bewegliches Probengestell ist und wobei Mittel bereitgestellt sind, um dem Sondenstrahl bezüglich der Bewegung der Probe zu folgen, wobei die Probe relativ zur festen Sammeloptik bewegbar ist, um Sammeln von gestreutem Licht in einer Mehrzahl von Abständen von dem Bestrahlungspunkt zu ermöglichen. 10
46. Vorrichtung nach einem der Ansprüche 31 bis 42, wobei die Sammeloptik optische Fasern umfasst, die in einer Mehrzahl von konzentrischen Kreisen um den Probenstrahl angeordnet sind. 20
47. Vorrichtung nach einem der Ansprüche 31 bis 45, wobei die Lichtquelle (101) ein Dauerstrichlaser ist. 25
48. Vorrichtung nach einem der Ansprüche 31 bis 46, wobei die Detektionsmittel eine CCD-Kamera umfassen. 30
49. Verfahren oder Vorrichtung nach einem der vorangehenden Ansprüche, wobei die Eintritts- oder Sammelbereiche bei einem aus der Mehrzahl von Abständen an der gleichen Stelle sind oder sich im Wesentlichen überlappen. 35
50. Verfahren oder Vorrichtung nach einem der Ansprüche 1 bis 48, wobei die Mehrzahl von Eintritts- und Sammelbereichen nicht-überlappend ist. 40

Revendications

1. Procédé de mesure d'une diffusion Raman subsurfacique à travers un échantillon (14) de diffusion diffuse, le procédé comprenant les étapes qui consistent :
- (a) à fournir un rayonnement incident au niveau d'une ou de plusieurs régions (11) sur une surface (12) de l'échantillon ;
- (b) à collecter la lumière qui s'est diffusée dans l'échantillon, à partir d'une ou de plusieurs régions de collecte (19) sur la surface, à une pluralité d'espacements d'une ou de plusieurs régions d'entrée ; et
- (c) à détecter, dans la lumière collectée, pour chaque espacement, une ou plusieurs caractéristiques Raman qui se rapportent en termes

spectraux au rayonnement incident, **caractérisé en ce que** le procédé comprend en outre le fait :

- (d) de dériver, à partir des changements au niveau des intensités de l'une ou des plusieurs caractéristiques Raman entre les différents espacements, une ou plusieurs caractéristiques d'une région (20) subsurfacique de l'échantillon (14), en combinant les caractéristiques Raman des différents espacements pour sélectionner les caractéristiques Raman pour une profondeur ou une plage de profondeurs particulières.
2. Procédé de la revendication 1 dans lequel l'étape (c) comprend, pour chaque espacement, la diffusion spectrale de la lumière collectée pour former un spectre Raman.
3. Procédé de la revendication 2 dans lequel l'étape (d) comprend l'analyse de la pluralité de spectres Raman pour extraire des informations sur le spectre Raman d'une région subsurfacique de l'échantillon.
4. Procédé de la revendication 1, 2 ou 3 dans lequel le rayonnement incident est fourni à une région d'entrée en irradiant l'échantillon avec une sonde de lumière à un point d'irradiation, et l'étape de collecte comprend la collecte de la lumière à une pluralité d'emplacements spatiaux de région de collecte sur la surface de l'échantillon, chaque emplacement spatial est situé à une distance différente du point d'irradiation.
5. Procédé de la revendication 4 dans lequel l'étape de dérivation comporte l'association des caractéristiques Raman de différents espacements avec des profondeurs ou distributions de profondeur différentes dans l'échantillon (14).
6. Procédé de l'une quelconque des revendications précédentes dans lequel l'étape de collecte comprend la collecte de lumière d'une pluralité de régions de collecte espacées par différentes distances d'une région d'entrée.
7. Procédé de l'une quelconque des revendications précédentes dans lequel une ou plusieurs régions de collecte entourent une région d'entrée (11).
8. Procédé de la revendication 7 dans lequel chaque région de collecte est un anneau (44), et pour chaque anneau, la lumière est collectée d'au moins 10%, et plus préférentiellement au moins 25% de la surface de l'anneau (44).
9. Procédé de l'une quelconque des revendications 7 ou 8 dans lequel la lumière diffusée est collectée par une pluralité de fibres optiques de collecte distri-

- buées autour d'une ou de plusieurs fibres optiques d'illumination utilisées pour fournir le rayonnement incident à la région d'entrée.
10. Procédé de l'une quelconque des revendications 1 à 6 dans lequel une ou plusieurs régions d'entrée entourent une région de collecte (48). 5
11. Procédé de l'une quelconque des revendications précédentes comprenant en outre le réglage d'une optique de collecte (18) disposée dans le chemin de la lumière collectée pour régler la distance entre une région de collecte (19) et une région d'entrée (11). 10
12. Procédé de l'une quelconque des revendications précédentes comprenant en outre la disposition d'un ou de plusieurs éléments miroirs (60) adjacents à la surface d'échantillon à l'extérieur des régions de collecte pour renvoyer la lumière dans l'échantillon. 15
13. Procédé pour mesurer un spectre Raman subsurfacique d'un échantillon de diffusion diffuse comme défini l'une quelconque des revendications précédentes, le procédé comprenant les étapes qui consistent : 20
- a) à irradier l'échantillon avec une sonde de lumière (105) ;
- b) à collecter la lumière diffusée par l'échantillon (106, 107) ; et 25
- c) à séparer en termes spectraux au moins une partie de la lumière collectée pour détecter une ou plusieurs caractéristiques Raman spectrales, où la lumière diffusée par l'échantillon est collectée à partir d'une pluralité d'emplacements spatiaux sur la surface de l'échantillon, chaque emplacement spatial est situé à une distance différente du point d'irradiation, au moins une partie de la lumière collectée au niveau de chaque emplacement spatial qui est diffusée séparément en termes spectraux pour former une pluralité de spectres Raman et où le procédé comporte en outre l'étape qui consiste : 30
- d) à analyser la pluralité de spectres Raman pour extraire des informations sur le spectre Raman d'une région subsurfacique de l'échantillon. 35
14. Procédé tel que revendiqué dans l'une quelconque des revendications précédentes, dans lequel au moins deux spectres Raman sont collectés et analysés en utilisant une soustraction échelonnée, le spectre Raman collecté à la distance la plus proche du point d'irradiation qui est soustrait du spectre Raman collecté plus loin du point d'irradiation, moyennant quoi les caractéristiques du spectre Raman pour une sous-couche de l'échantillon sont identifiées. 40
15. Procédé tel que revendiqué dans l'une quelconque des revendications 1 à 13, dans lequel le spectre Raman pour la composition chimique de la surface de l'échantillon est connu et les spectres Raman sont analysés par une soustraction échelonnée du spectre Raman connu à partir des spectres Raman de la lumière collectée. 45
16. Procédé tel que revendiqué dans l'une quelconque des revendications 1 à 13, dans lequel la pluralité de spectres Raman sont analysés en utilisant une analyse de données multivariées. 50
17. Procédé tel que revendiqué dans la revendication 16, dans lequel la pluralité de spectres Raman sont analysés en utilisant une analyse en composantes principales. 55
18. Procédé tel que revendiqué dans l'une quelconque des revendications 16 ou 17, dans lequel au moins dix spectres Raman sont collectés à différentes distances du point d'irradiation.
19. Procédé tel que revendiqué dans l'une quelconque des revendications précédentes, dans lequel l'échantillon est irradié à deux longueurs d'ondes différentes ou plus et la lumière collectée est une combinaison d'un spectre Raman et d'une fluorescence et où le procédé comprend l'étape supplémentaire qui consiste à extraire le spectre Raman de la lumière collectée.
20. Procédé tel que revendiqué dans l'une quelconque des revendications précédentes, dans lequel au moins l'un de l'échantillon, de l'optique de collecte, et du point ou la région d'irradiation est déplacé par rapport aux autres pour permettre la collecte des spectres Raman à différentes distances du point d'irradiation.
21. Procédé tel que revendiqué dans la revendication 20, dans lequel un étage mobile est pourvu sur lequel l'échantillon est monté et le faisceau sonde est agencé pour suivre le mouvement de l'échantillon moyennant quoi l'échantillon est déplacé par rapport à l'optique de collecte fixe pour la collecte de la lumière diffusée à différentes distances du point d'irradiation.
22. Procédé tel que revendiqué dans la revendication 21, dans lequel la lumière diffusée est collectée à partir des régions de point à différentes distances du point d'irradiation.
23. Procédé tel que revendiqué dans la revendication 21, dans lequel la lumière diffusée est collectée à partir d'une pluralité de lignes essentiellement pa-

rallèles qui sont essentiellement transversales à la distance comme mesuré à partir du point d'irradiation.

24. Procédé tel que revendiqué dans l'une quelconque des revendications 13 à 20, dans lequel le faisceau sonde est fourni en utilisant des fibres optiques et la lumière diffusée est collectée en utilisant des fibres optiques agencées dans une pluralité de cercles concentriques autour des fibres optiques du faisceau sonde moyennant quoi la lumière diffusée est collectée dans des anneaux concentriques à différents rayons du point d'irradiation. 5
25. Procédé tel que revendiqué dans l'une quelconque des revendications précédentes, dans lequel la lumière collectée est dispersée en termes spectraux en utilisant un spectromètre en combinaison avec une caméra CCD (103). 10
26. Procédé tel que revendiqué dans l'une quelconque des revendications précédentes, dans lequel la sonde de lumière ou le rayonnement incident est généré (e) en utilisant un laser (101) à ondes continues. 15
27. Procédé tel que revendiqué dans la revendication 20, dans lequel la sonde de lumière comprend deux longueurs d'ondes séparées ou plus et est générée par un ou plusieurs lasers. 20
28. Procédé tel que revendiqué dans la revendication 27, dans lequel la sonde de lumière est générée par un laser accordable unique. 25
29. Procédé tel que revendiqué dans la revendication 27, dans lequel les deux longueurs d'ondes séparées ou plus de la sonde de lumière sont générées par deux lasers respectifs ou plus. 30
30. Procédé tel que revendiqué dans l'une quelconque des revendications 26 à 29, dans lequel la sonde de lumière fournit un rayonnement à une longueur d'onde > 200 nm et < 2000 nm. 35
31. Appareil de mesure d'une diffusion Raman subsurfacique à travers un échantillon (14) de diffusion diffuse, comprenant : 40

une source (9) de lumière agencée pour fournir un rayonnement incident à une ou plusieurs régions d'entrée sur une surface de l'échantillon ; un collecteur (18) agencé pour collecter la lumière diffusée dans l'échantillon, à partir d'une ou de plusieurs régions de collecte (19) sur la surface, à une pluralité d'espacements de l'une ou des plusieurs régions d'entrée (11) ; un détecteur (22) agencé pour détecter, pour chaque espacement, une ou plusieurs caracté-

ristiques Raman qui se rapportent manière spectrale au rayonnement incident, **caractérisé en ce que** l'appareil comprend en outre :

- un analyseur (23) adapté pour dériver, à partir des intensités des caractéristiques Raman au niveau des différents espacements, une ou plusieurs caractéristiques d'une région (20) subsurfacique de l'échantillon, en combinant les caractéristiques Raman à partir de ladite pluralité d'espacements pour sélectionner les caractéristiques pour une profondeur ou plage de profondeurs particulières. 15
32. Appareil de la revendication 31 adapté pour fournir un rayonnement incident à une région d'entrée en irradiant l'échantillon avec une sonde de lumière à un point d'irradiation, et pour collecter la lumière à une pluralité d'emplacements spatiaux de la région de collecte sur la surface de l'échantillon, chaque emplacement spatial étant situé à une distance différente du point d'irradiation. 20
33. Appareil de l'une quelconque des revendications 31 à 32, dans lequel l'analyseur est adapté pour identifier des caractéristiques spécifiques au spectre Raman d'une sous-couche de l'échantillon à partir des caractéristiques Raman. 25
34. Appareil de l'une quelconque des revendications 31 à 33, dans lequel le détecteur (22) comprend un spectromètre agencé pour disperser en termes spectraux la lumière collectée afin de séparer lesdites caractéristiques Raman pour chaque espacement. 30
35. Appareil de l'une quelconque des revendications 31 à 33, dans lequel le détecteur (22) comprend un ou plusieurs filtres agencés pour transmettre au choix lesdites caractéristiques Raman pour chaque espacement. 35
36. Appareil de l'une quelconque des revendications 31 à 35 dans lequel soit la région d'entrée soit la région de collecte est une région annulaire. 40
37. Appareil de la revendication 36 comprenant en outre un agencement optique (50) adapté pour régler de manière commandée le diamètre de la région annulaire. 45
38. Appareil de l'une quelconque des revendications 31 à 36 comprenant en outre un dispositif de masquage agencé pour régler de manière commandée l'espacement entre la région d'entrée et la région de collecte. 50

39. Appareil de l'une quelconque des revendications 31 à 38 comprenant en outre un ou plusieurs éléments miroirs (60) disposés adjacents à la surface d'échantillon à l'extérieur de l'une ou des plusieurs régions de collecte et d'entrée de sorte à renvoyer la lumière dans l'échantillon. 5
40. Appareil pour mesurer au choix des spectres Raman générés à différentes profondeurs dans un milieu de diffusion diffuse, comme indiqué dans l'une quelconque des revendications 31 à 30, l'appareil comprenant :
- une source (101) de lumière pour irradier un échantillon avec un faisceau sonde ;
 une optique de collecte (109) pour collecter la lumière diffusée par l'échantillon et la transmettre à un spectromètre (102) ;
 un moyen de détection (103) pour détecter la lumière dispersée par le spectromètre, où l'appareil est adapté pour la lumière diffusée de sorte qu'elle soit collectée à une pluralité d'emplacements spatiaux sur la surface de l'échantillon, chaque emplacement spatial est situé à une distance différente du point d'irradiation et au moins une partie de la lumière collectée au niveau de chaque emplacement spatial est dispersée séparément en termes spectraux par le spectromètre pour former une pluralité de spectres Raman et où l'appareil comporte en outre un analyseur (104) pour identifier des caractéristiques spécifiques au spectre Raman d'une sous-couche de l'échantillon à partir de la pluralité de spectres Raman. 10 15 20 25 30 35
41. Appareil tel que revendiqué dans l'une quelconque des revendications 31 à 40, dans lequel l'analyseur (104) est adapté pour exécuter une soustraction échelonnée entre les spectres Raman. 40
42. Appareil tel que revendiqué dans l'une quelconque des revendications 31 à 40, dans lequel l'analyseur (104) est adapté pour exécuter une analyse de données multivariées sur les spectres Raman. 45
43. Appareil tel que revendiqué dans la revendication 42, dans lequel l'analyseur (104) est adapté pour exécuter une analyse en composantes principales sur les spectres Raman. 50
44. Appareil tel que revendiqué dans l'une quelconque des revendications 31 à 42, comprenant en outre un étage mobile pour un mouvement relatif d'au moins l'un de l'échantillon, de l'optique de collecte et du point d'irradiation pour permettre la collecte des spectres Raman à différentes distances du point d'irradiation. 55
45. Appareil tel que revendiqué dans la revendication 44, dans lequel l'étage mobile est un étage d'échantillon mobile et où un moyen est prévu pour suivre le faisceau sonde par rapport au mouvement de l'échantillon moyennant quoi l'échantillon peut être déplacé par rapport à l'optique de collecte fixe pour permettre la collecte de la lumière diffusée à une pluralité de distances à partir du point d'irradiation.
46. Appareil tel que revendiqué dans l'une quelconque des revendications 31 à 42, dans lequel l'optique de collecte comprend des fibres optiques agencées dans une pluralité de cercles concentriques autour du faisceau sonde. 10 15
47. Appareil tel que revendiqué dans l'une quelconque des revendications 31 à 45, dans lequel la source (101) de lumière est un laser à ondes continues. 20
48. Appareil tel que revendiqué dans l'une quelconque des revendications 31 à 46, dans lequel le moyen de détection comprend une caméra CCD. 25
49. Procédé ou appareil de l'une quelconque des revendications précédentes dans lequel à l'un de la pluralité d'espacements les régions d'entrée et de collecte sont situées au même endroit ou se chevauchent essentiellement. 30
50. Procédé ou appareil de l'une quelconque des revendications 1 à 48 dans lequel la pluralité de régions d'entrée et de collecte ne se chevauchent pas. 35 40 45 50 55

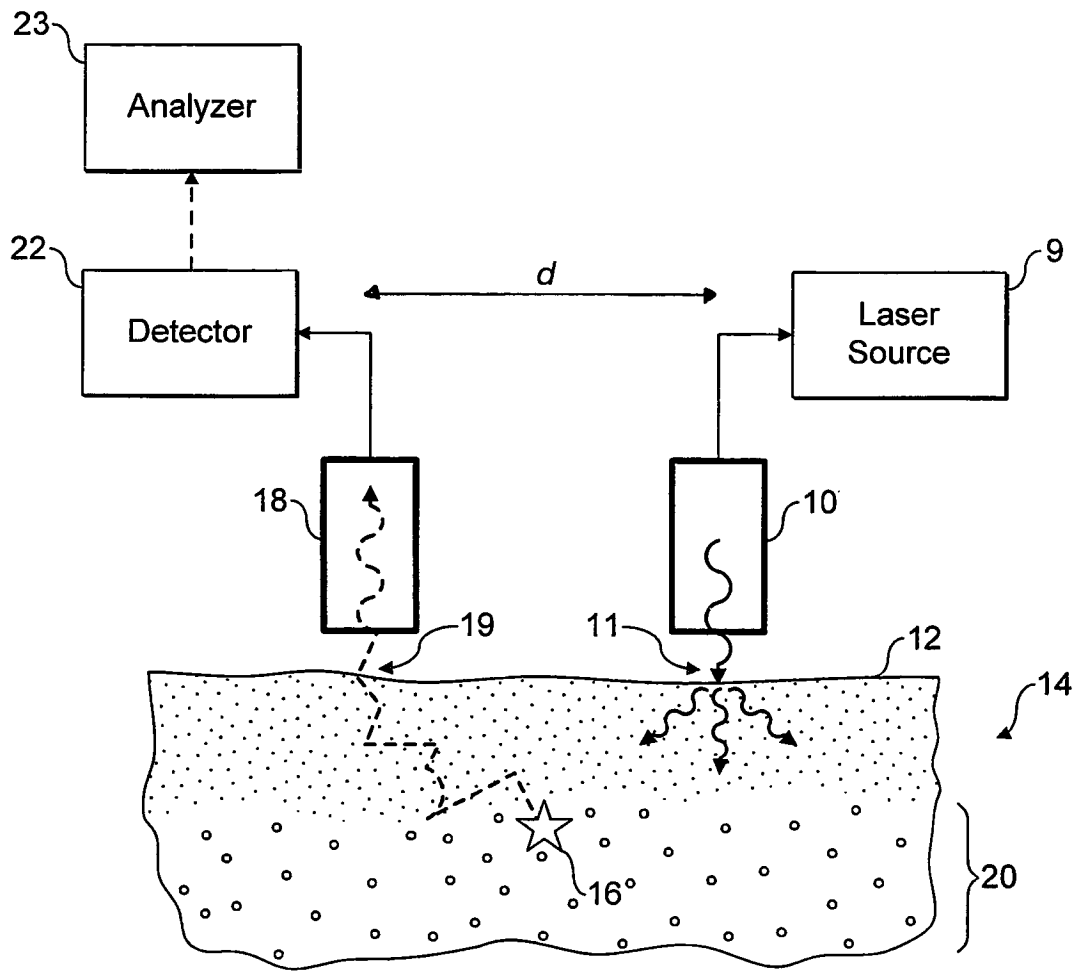

FIG. 1

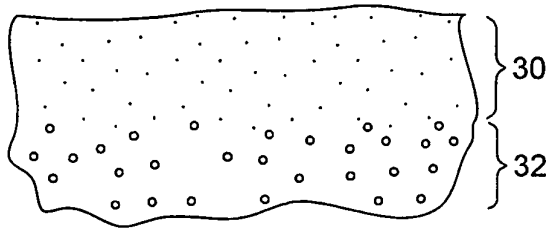

FIG. 2a

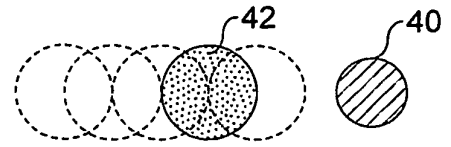

FIG. 3a

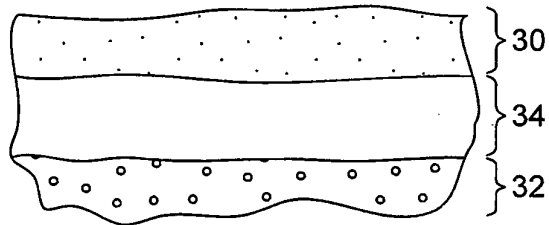

FIG. 2b

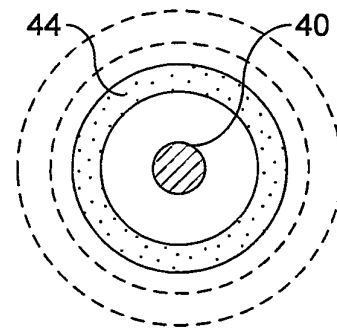

FIG. 3b

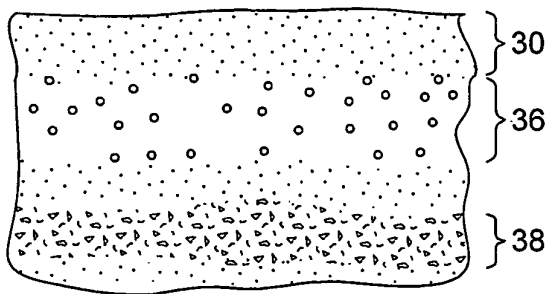

FIG. 2c

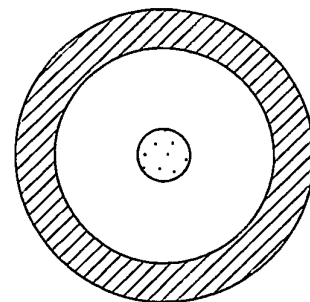

FIG. 3c

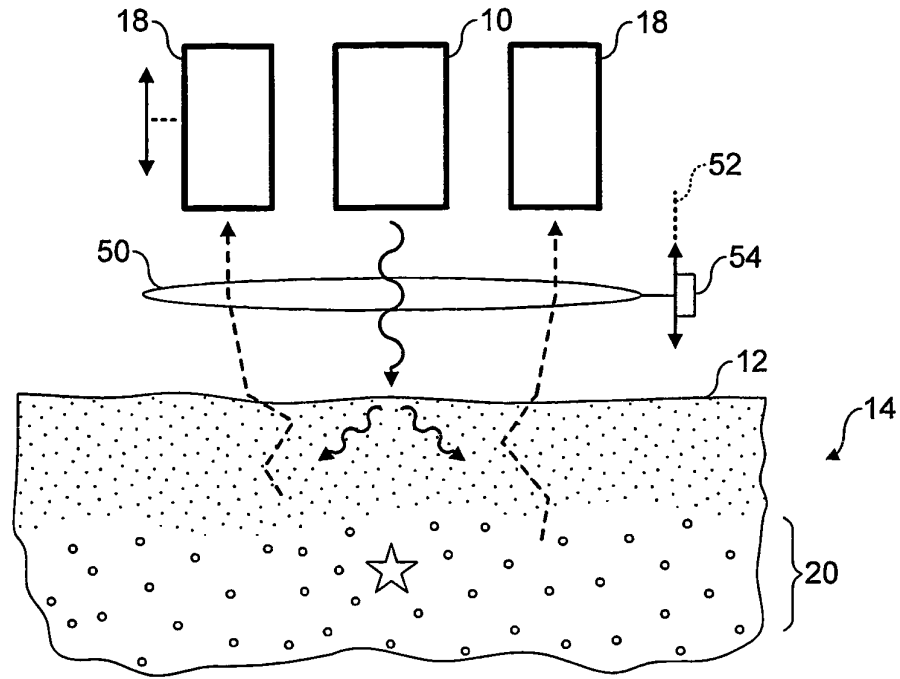

FIG. 4

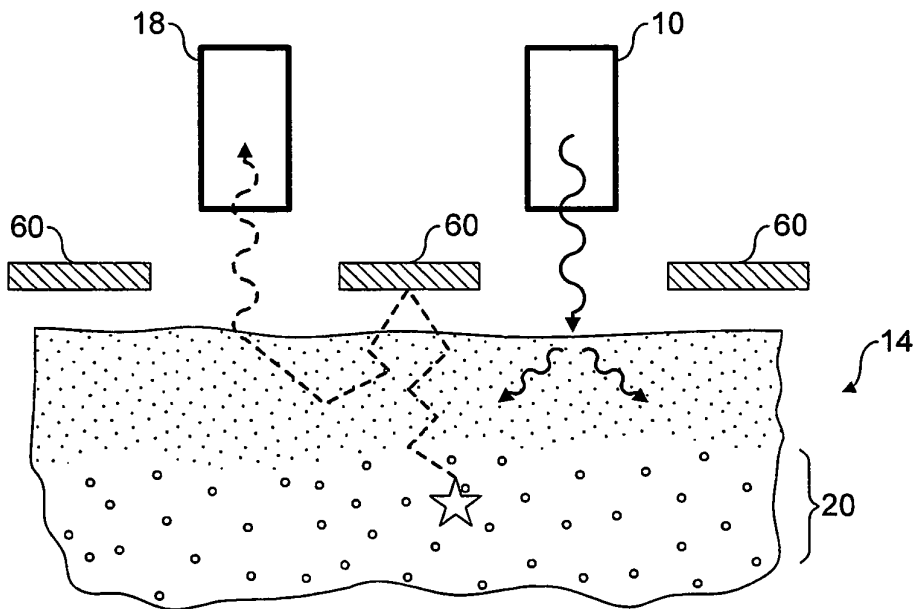

FIG. 5

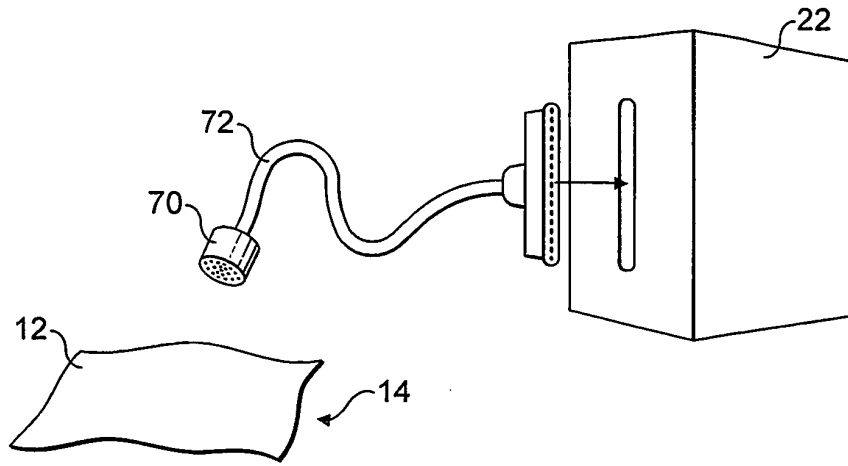

FIG. 6

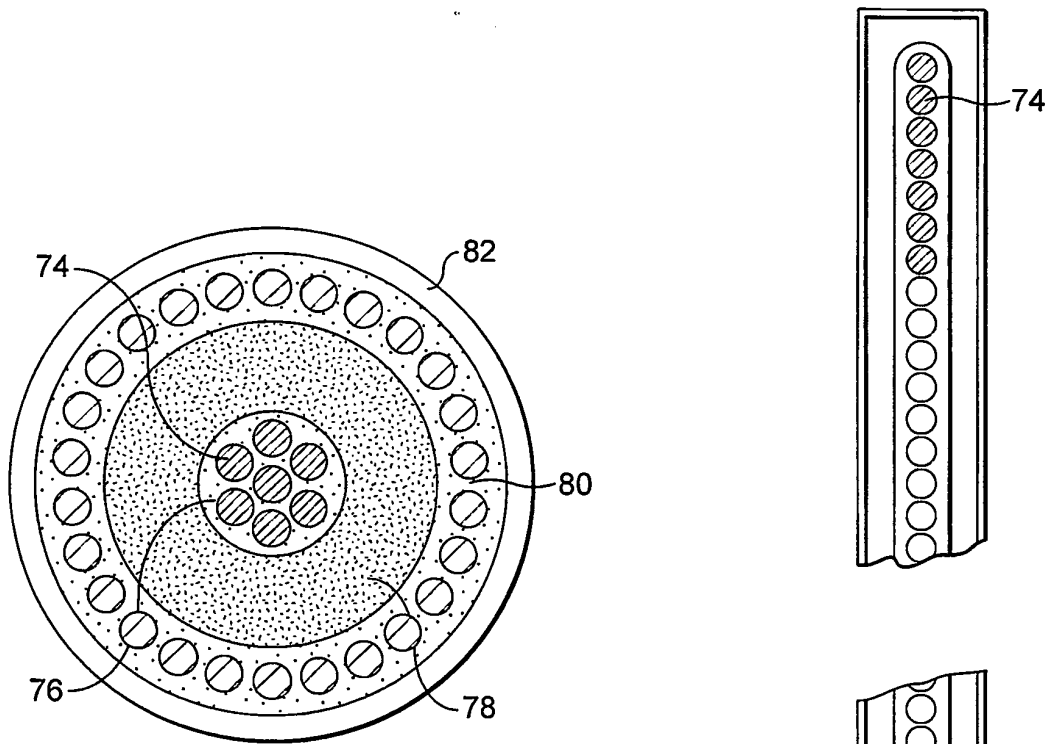

FIG. 7a

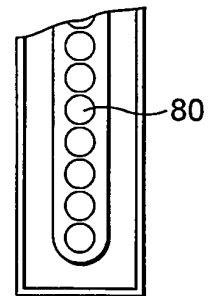
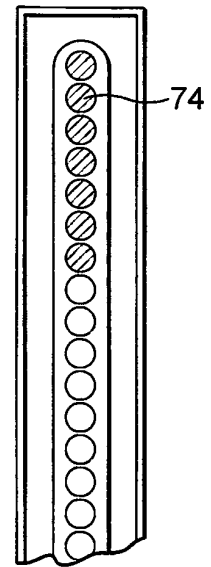

FIG. 7b

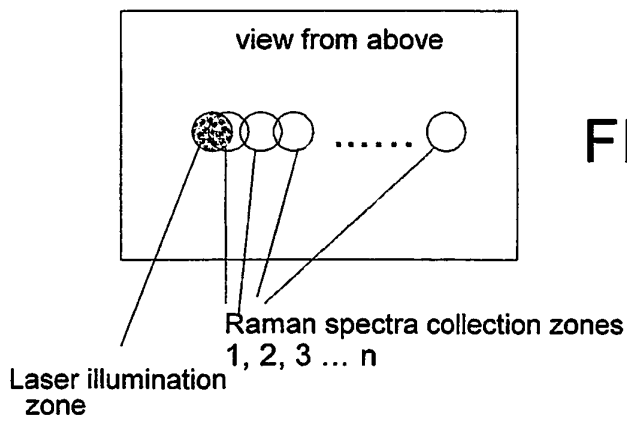
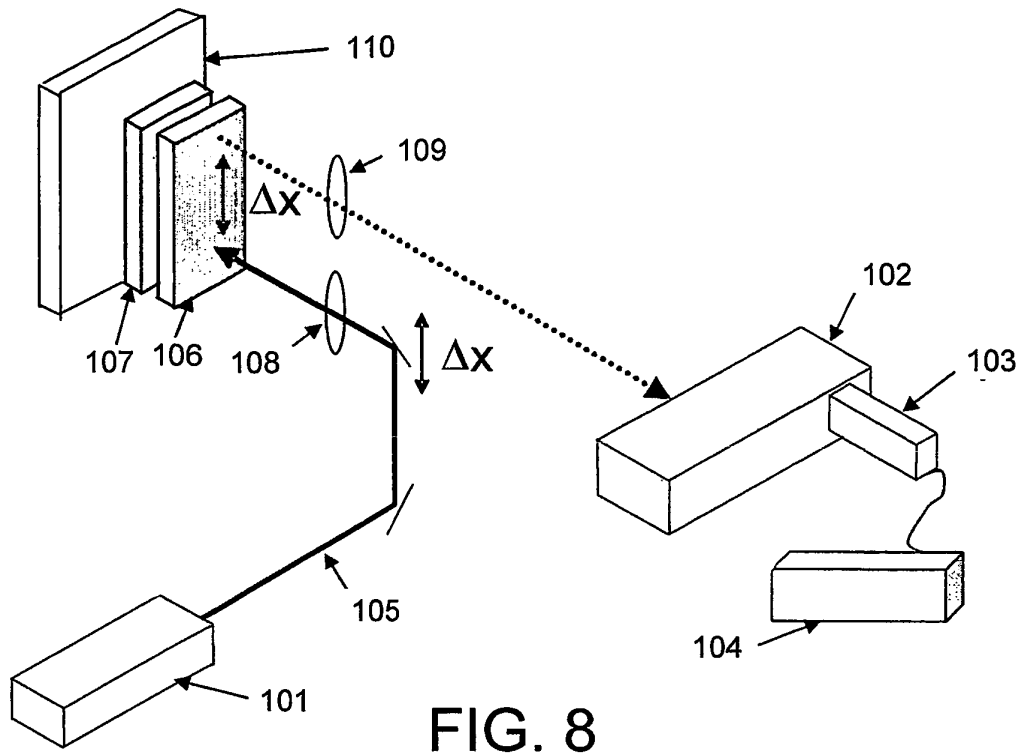
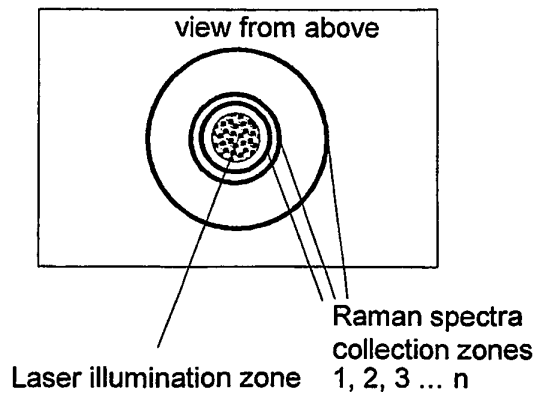

FIG. 9

FIG. 10



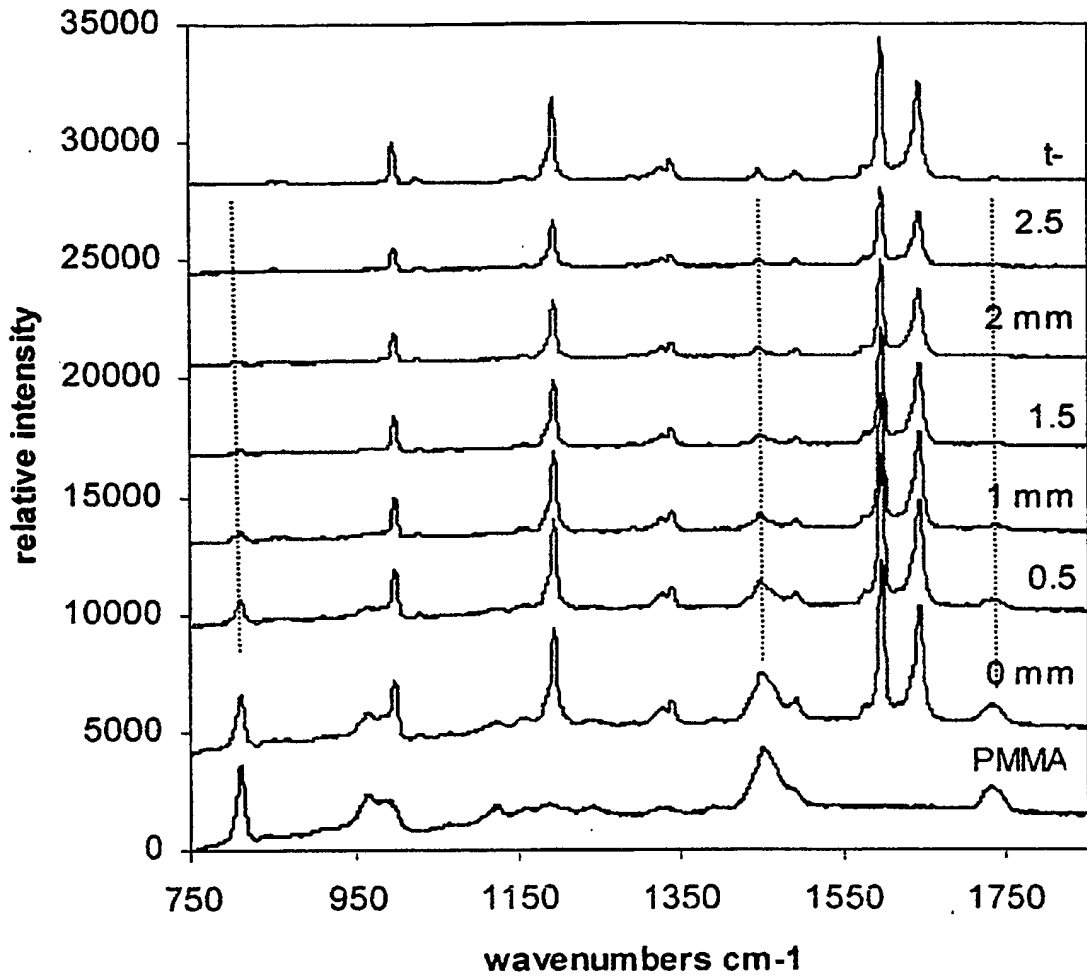

FIG. 11

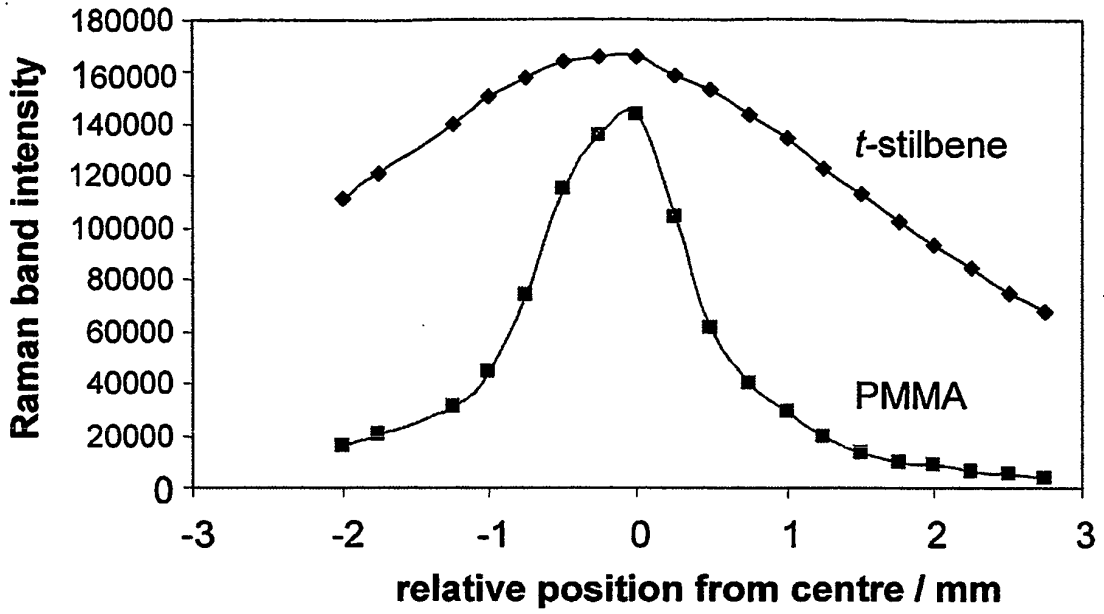

FIG. 12

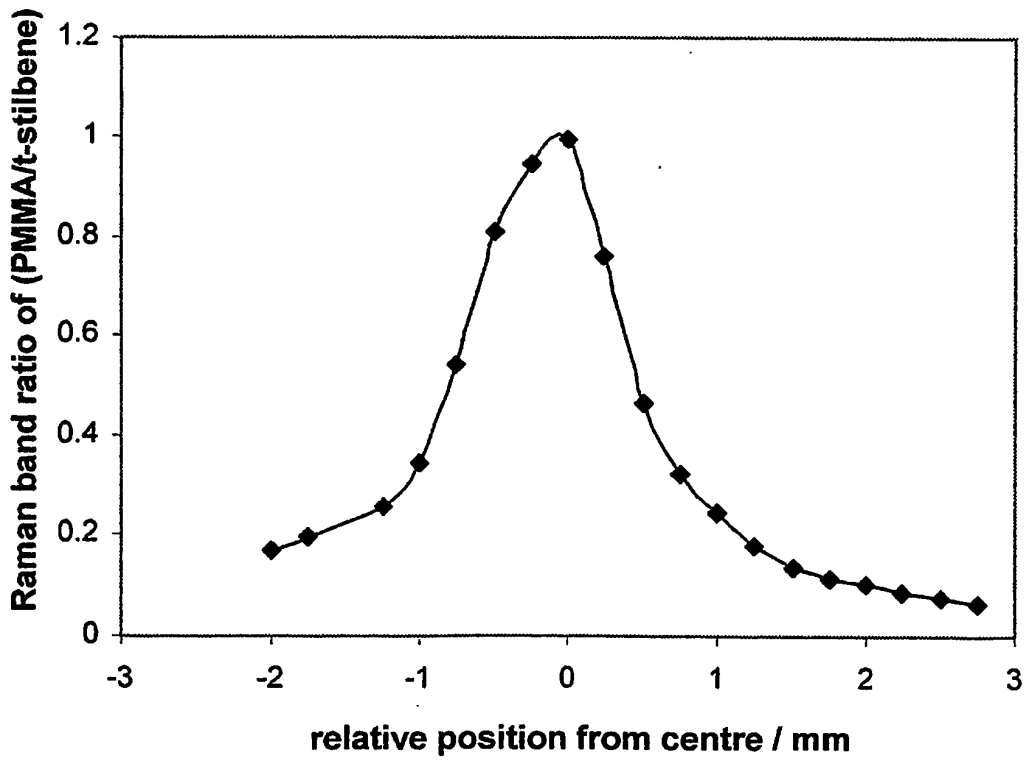

FIG. 13

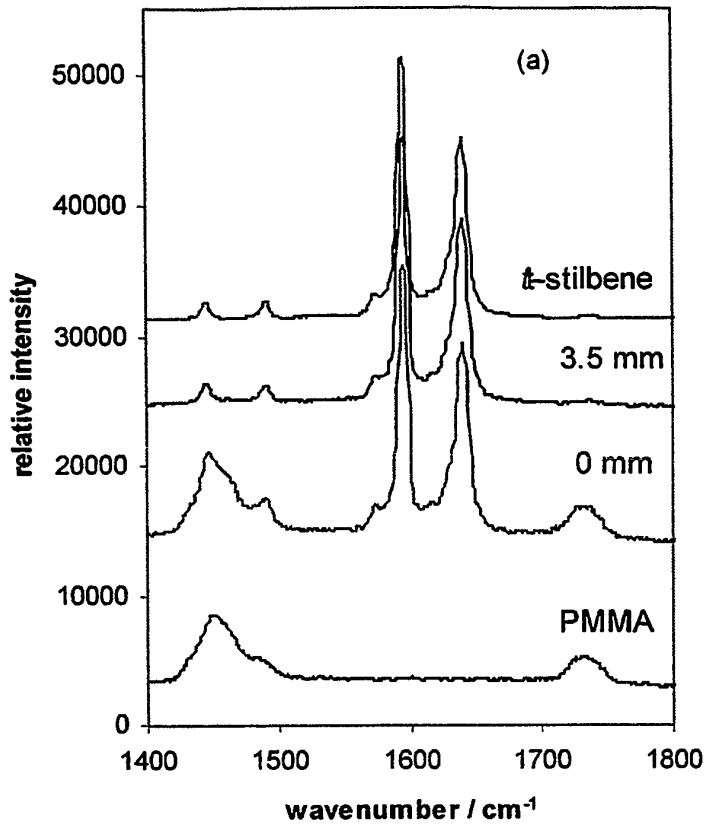

FIG. 14

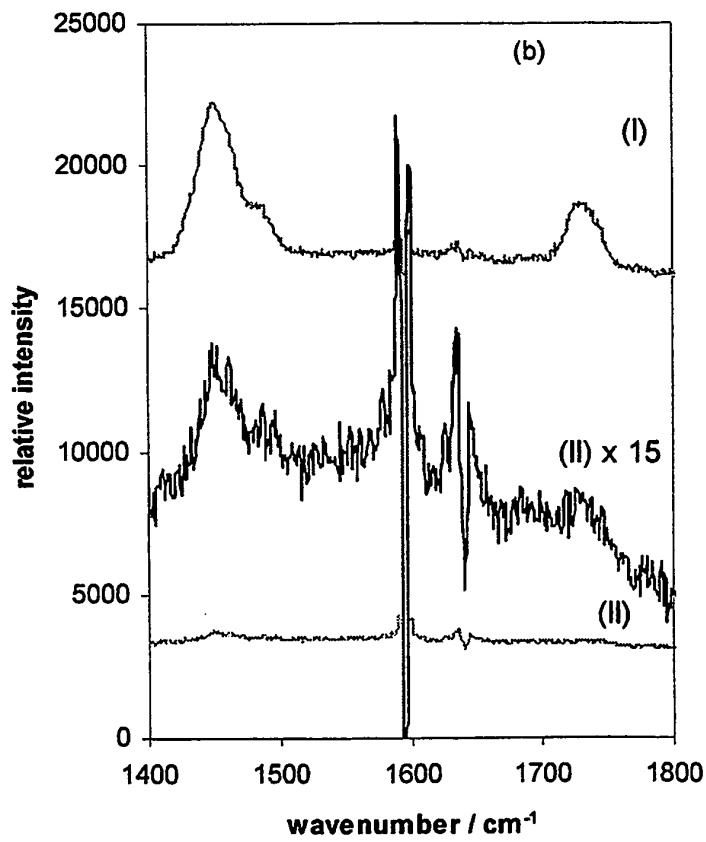

FIG. 15

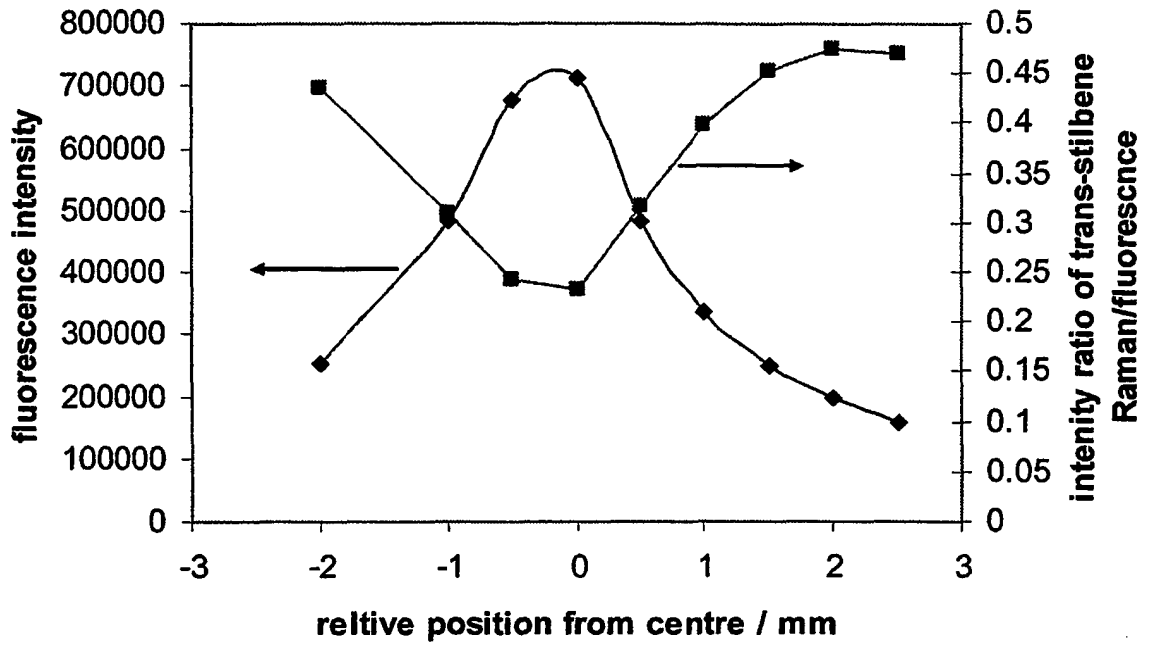
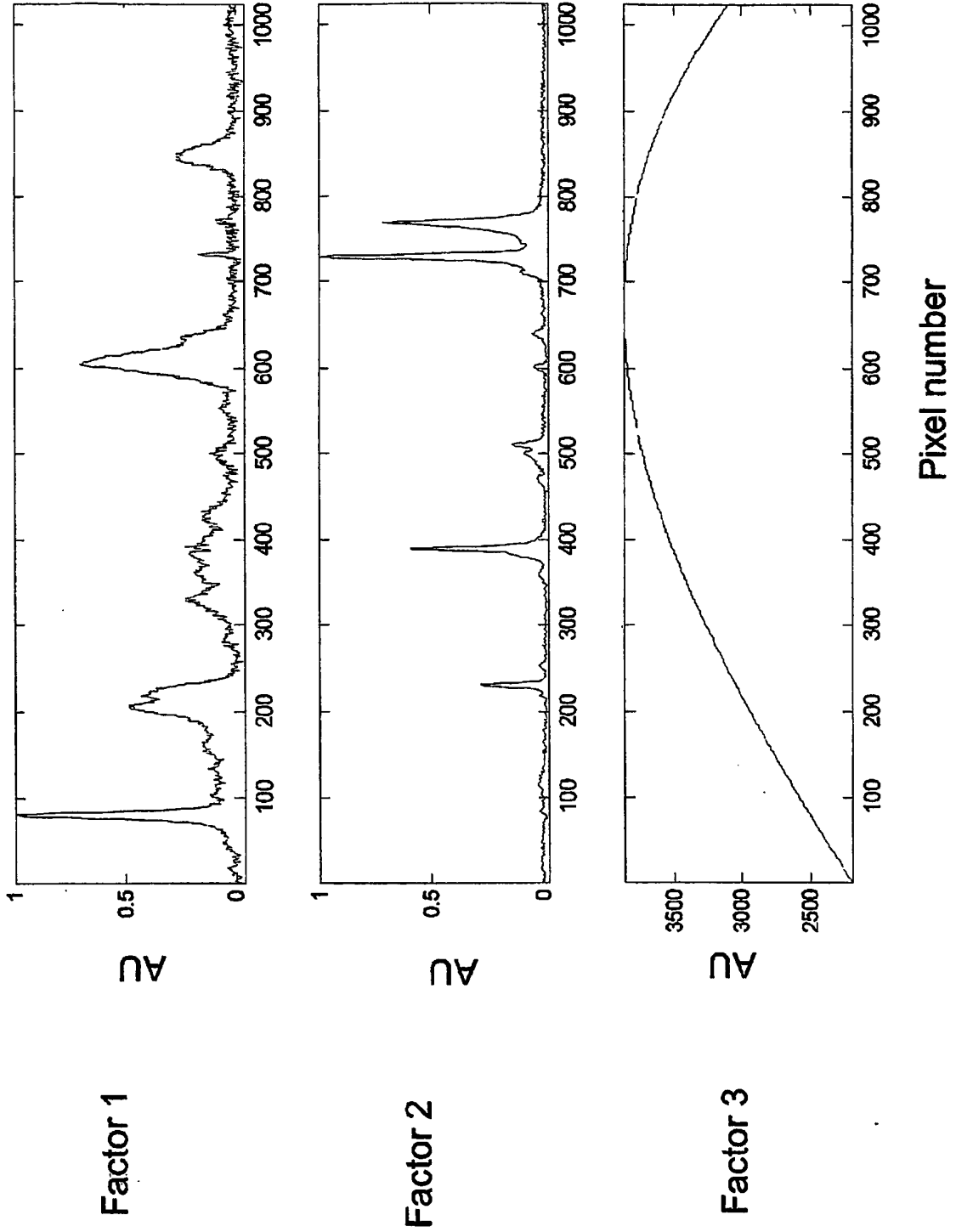

FIG. 16

FIG. 17



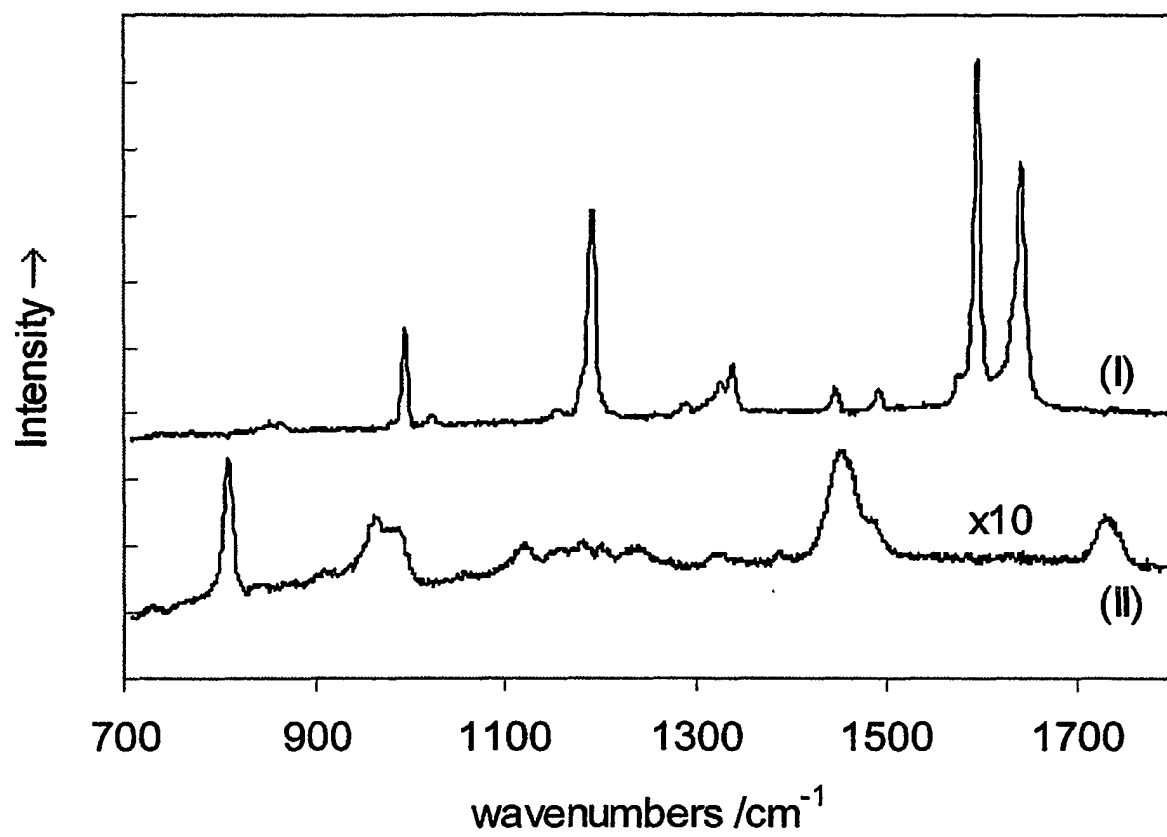

FIG. 18

REFERENCES CITED IN THE DESCRIPTION

This list of references cited by the applicant is for the reader's convenience only. It does not form part of the European patent document. Even though great care has been taken in compiling the references, errors or omissions cannot be excluded and the EPO disclaims all liability in this regard.

Patent documents cited in the description

- US 6681133 B [0005]
- WO 0152739 A [0005]
- WO 9626431 A [0007]

Non-patent literature cited in the description

- **A. Carden ; M. D. Morris.** *J. Biomed. Optics*, 2000, vol. 5, 259 [0003]
- **B.B.Das et al.** *Rep. Prog. Phys.*, 1997, vol. 60, 227 [0006]
- **Jiaying Ma ; Dor Ben-Amotz.** Rapid Micro-Raman Imaging using Fiber-Bundle Image Compression. *Applied Spectroscopy*, 1997, vol. 51 (12 [0053]
- **S. E. J. Bell ; E. S. O. Bourguignon ; A. C. Dennis.** Subtracted shifted Raman spectroscopy (SSRS) method. *Analyst*, 1998, vol. 123, 1729-1734 [0057]
- **P. Matousek ; M. Towrie ; A. W. Parker ; IJ. Raman.** *Spec.*, 2002, vol. 33, 128-242 [0057]

专利名称(译)	用于深度选择性拉曼光谱的装置		
公开(公告)号	EP1828753B1	公开(公告)日	2011-04-13
申请号	EP2005809242	申请日	2005-11-25
申请(专利权)人(译)	科学与技术设施委员会		
当前申请(专利权)人(译)	科学与技术设施委员会		
[标]发明人	MATOUSEK PAVEL PARKER ANTHONY WILLIAM		
发明人	MATOUSEK, PAVEL PARKER, ANTHONY, WILLIAM		
IPC分类号	G01N21/65 G01N21/49 G01N21/47 A61B5/00 A61B5/103		
CPC分类号	A61B5/0059 A61B5/0071 A61B5/0075 A61B5/441 A61B5/4504 G01N21/65 G01N2021/656		
优先权	2004026993 2004-12-09 GB 60/669880 2005-04-11 US		
其他公开文献	EP1828753A1		
外部链接	Espacenet		

摘要(译)

公开了用于从漫散射样品的亚表面区域非破坏性地检测拉曼光谱特征的装置和方法。在一个或多个样品表面进入区域处提供入射辐射，并且从与入口区域间隔开的一个或多个收集区域收集光。在收集的光中检测拉曼特征，并根据入口 - 收集间距导出深度信息。

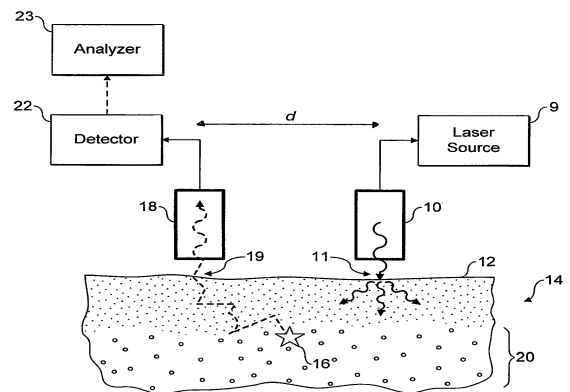

FIG. 1