

(19) World Intellectual Property Organization
International Bureau



(43) International Publication Date
18 May 2012 (18.05.2012)

(10) International Publication Number
WO 2012/061940 A1

(51) International Patent Classification:

A61B 5/00 (2006.01) A61M 5/00 (2006.01)
A61B 8/12 (2006.01) G06T 7/00 (2006.01)
A61B 8/13 (2006.01)

1E2 (CA). THIND, Amandeep [CA/CA]; 71 Northey Drive, Toronto, Ontario M2L 2S8 (CA).

(74) Agent: HILL & SCHUMACHER; 264 Avenue Road, Toronto, Ontario M4V 2G7 (CA).

(21) International Application Number:

PCT/CA2011/050693

(81) Designated States (unless otherwise indicated, for every kind of national protection available): AE, AG, AL, AM, AO, AT, AU, AZ, BA, BB, BG, BH, BR, BW, BY, BZ, CA, CH, CL, CN, CO, CR, CU, CZ, DE, DK, DM, DO, DZ, EC, EE, EG, ES, FI, GB, GD, GE, GH, GM, GT, HN, HR, HU, ID, IL, IN, IS, JP, KE, KG, KM, KN, KP, KR, KZ, LA, LC, LK, LR, LS, LT, LU, LY, MA, MD, ME, MG, MK, MN, MW, MX, MY, MZ, NA, NG, NI, NO, NZ, OM, PE, PG, PH, PL, PT, QA, RO, RS, RU, RW, SC, SD, SE, SG, SK, SL, SM, ST, SV, SY, TH, TJ, TM, TN, TR, TT, TZ, UA, UG, US, UZ, VC, VN, ZA, ZM, ZW.

(22) International Filing Date:

8 November 2011 (08.11.2011)

(25) Filing Language:

English

(26) Publication Language:

English

(30) Priority Data:

61/411,225 8 November 2010 (08.11.2010) US

(71) Applicant (for all designated States except US): COLIBRI TECHNOLOGIES INC. [CA/CA]; 3080 Yonge Street, Suite 3030, Toronto, Ontario M4N 3N1 (CA).

(72) Inventors; and

(75) Inventors/Applicants (for US only): COURTNEY, Brian [CA/CA]; 374 Balliol Street, Toronto, Ontario M4S

(84) Designated States (unless otherwise indicated, for every kind of regional protection available): ARIPO (BW, GH, GM, KE, LR, LS, MW, MZ, NA, RW, SD, SL, SZ, TZ, UG, ZM, ZW), Eurasian (AM, AZ, BY, KG, KZ, MD, RU, TJ, TM), European (AL, AT, BE, BG, CH, CY, CZ,

[Continued on next page]

(54) Title: SYSTEMS AND METHODS FOR IMPROVED VISUALIZATION DURING MINIMALLY INVASIVE PROCEDURES

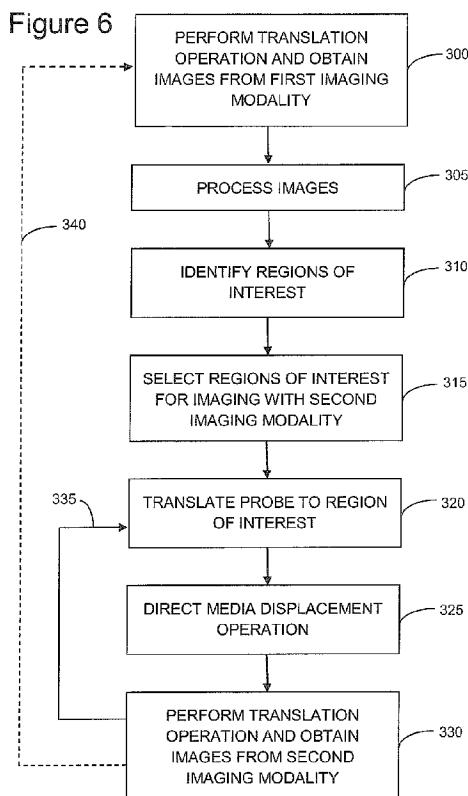

(57) Abstract: Systems and methods are provided for performing a minimally invasive procedure in an automated or semi-automated fashion, where an imaging probe having an imaging modality compatible with the presence of an intraluminal medium is employed to record images that are processed to identify regions of interest and direct a medium displacement operation during a subsequent minimally invasive operation that benefits from the displacement of the intraluminal medium. The minimally invasive operation may include recording images with a second imaging modality, or may be a therapeutic treatment. The method is may be performed in real-time, where images obtained from the first imaging modality are processed in real time to determine whether or not the minimally invasive operation is to be performed at a given position.

WO 2012/061940 A1

DE, DK, EE, ES, FI, FR, GB, GR, HR, HU, IE, IS, IT,
LT, LU, LV, MC, MK, MT, NL, NO, PL, PT, RO, RS,
SE, SI, SK, SM, TR), OAPI (BF, BJ, CF, CG, CI, CM,
GA, GN, GQ, GW, ML, MR, NE, SN, TD, TG).

— *before the expiration of the time limit for amending the
claims and to be republished in the event of receipt of
amendments (Rule 48.2(h))*

Published:

— *with international search report (Art. 21(3))*

SYSTEMS AND METHODS FOR IMPROVED VISUALIZATION DURING MINIMALLY INVASIVE PROCEDURES

CROSS-REFERENCE TO RELATED APPLICATION

5 This application claims priority to U.S. Provisional Application No.
61/411,225, titled "SYSTEMS AND METHODS FOR IMPROVED
VISUALIZATION DURING MINIMALLY INVASIVE PROCEDURES" and filed on
November 8th, 2010, the entire contents of which are incorporated herein by
reference.

10

BACKGROUND

The present disclosure relates generally to the field of high resolution
medical imaging. More particularly, the present disclosure relates to minimally
invasive methods involving two or more imaging modalities.

15

High resolution medical imaging has broad diagnostic utility, including
assessing tissue structures, anatomy and/or composition, planning and/or
guiding interventions on localized regions of the body, and assessing the result of
interventions that alter the structure, composition or other properties of the
localized region. Among the many different high resolution imaging modalities,
20 high frequency ultrasound and optical coherence tomography are two highly
useful clinical and research tools.

20

High frequency ultrasound is a technique that is particularly useful for
intravascular and intracardiac procedures. For these applications, one or more
ultrasound transducers are incorporated into a catheter or other device that can
25 be inserted into the body. Two particularly important implementations of high

frequency ultrasound are intravascular ultrasound (IVUS), for imaging blood vessels, and intracardiac echocardiography (ICE) for imaging cardiac chambers. Both ICE and IVUS are minimally invasive, and involve placing one or more ultrasound transducers inside a blood vessel or cardiac chamber to take high
5 quality images of these structures.

The center frequency of IVUS typically lies within the range of 3 to 200 MHz and more typically in the range of 8 to 80 MHz. Higher frequencies provide higher resolution but result in worse signal penetration and thus a smaller field of view. Depth of penetration can range from less than a millimeter to several
10 centimeters depending on several parameters such as center frequency and geometry of the transducer, the attenuation of the media through which the imaging occurs and implementation-specific specifications that affect the signal to noise ratio of the system.

High resolution imaging methods often involve the use of a rotary shaft to
15 transmit torque to an imaging device near the distal end of the probe. These rotary shafts are often long, thin and flexible so that they can be delivered through anatomical conduits, such as the vasculature, genitourinary tracts, respiratory tracts and other such bodily lumens. Ideally, when torque is applied to the cable in a specified direction the torque cable develops a property of
20 having a close relation between the degree of rotation at its proximal and distal ends. This allows the simplification of the design of an ultrasound catheter by making the angle of rotation at the distal end of the torque cable (within the body)

a reasonable approximation of the angle of rotation at the proximal end of the torque cable (outside of the body).

Other imaging systems operate without a torque cable, such as angioscopy catheters (which employ fiber optic bundles) and phased array
5 imaging systems. Additionally, imaging systems have been proposed and demonstrated that incorporate a micro-motor in the distal end of the catheter instead of relying on a torque cable.

Variations of high frequency ultrasound exist, where the signal acquisition and/or analysis of the backscattered signal is modified to facilitate obtaining or
10 inferring further information about the imaged tissue. These include elastography, where the strain within tissue is assessed as the tissue is compressed at different blood pressures (de Korte et al Circulation. 2002 Apr 9;105(14):1627-30); Doppler imaging which assesses motion such as blood flow within anatomic structures; virtual histology, which attempts to infer the
15 composition of tissue using the radio-frequency properties of the backscattered signal combined with a pattern recognition algorithm (Nair, U.S. Patent No.6,200,268); second harmonic imaging (Goertz et al, Invest Radiol. 2006 Aug;41(8):631-8) and others. Ultrasound transducers are improving considerably, including the use of single crystal ultrasound transducers and composite
20 ultrasound transducers.

A catheter-based system for intravascular ultrasound is described by Yock (U.S. Patent No. 4,794,931) to provide high resolution imaging of structures in blood vessels. This system comprises an outer sheath, within which there is an

ultrasound transducer near the distal end of a long torque cable. When a motor rotates the torque cable and ultrasound transducer assembly, 2D cross-sectional images of anatomical structures, such as blood vessels, can be made. Linear translation of the catheter or the torque cable and ultrasound transducer in
5 combination with the rotational motion of the ultrasound transducer allows for acquisition of a series of 2D images along the length of the catheter.

Hossack et al (WO/2006/121851) describe a forward looking ultrasound transducer using a CMUT transducer and a reflective surface.

Optical imaging methods based on fiber optic technology used in the field
10 of medicine include optical coherence tomography (OCT), angioscopy, near infrared spectroscopy, Raman spectroscopy and fluorescence spectroscopy. These modalities typically require the use of one or more optical fibers to transmit light energy along a shaft between an imaging site and an imaging detector.

Optical coherence tomography is an optical analog of ultrasound, and
15 provides imaging resolutions on the order of 1 to 30 microns, but does not penetrate as deeply into tissue as ultrasound in most cases. Fiber optics can also be used to deliver energy for therapeutic maneuvers such as laser ablation of tissue and photodynamic therapy. Other useful optical imaging modalities include endoscopy and other similar or related imaging mechanisms that involve
20 the use of a probe to obtain images based on the back-reflection of light.

Miniaturization of detectors and light sources is making it possible to include the light sources and / or detectors in the catheter itself, potentially obviating the

need for fiber optics to act as an intermediary component in the transmission and / or detection of light.

Optical coherence tomography is limited by its small penetration depth (on the order of 500 to 3000 microns) in most biologic media. Most such media, including blood, are not optically transparent. OCT has thus far required the displacement of blood to create an optically clear environment for this purpose. One approach is to displace the blood with another fluid prior to performing measurements with the imaging modality incompatible with blood. US Patent No. 7,625,366, issued to Atlas, provides an exemplary flush catheter for injecting a flush solution into a vessel for performing OCT measurements with minimal blood displacement. Fluids that have been either used or contemplated for this purpose include radio-opaque contrast or various formulations of saline, Ringer's lactate and others. US Patent Nos. 7,794,446 (issued to Bosse et al.) and US Patent No. 7,747,315 (issued to Villard et al.) disclose improved flush solution compositions for use in OCT imaging.

Displacement of blood by the introduction of another fluid with greater transparency provides a time interval in which optical coherence tomography imaging can occur. This time window can be extended by reducing the flow within the vessel, such as by the use guide catheters that incorporate an occlusion balloon. For example, US Patent Nos. 5,722,403, 5,740,808, 5,752,158, 5,848,969, 5,904,651, and 6,047,218, issued to McGee et al., provide imaging catheter systems including an inflatable balloon that incorporates an

imaging apparatus. US Patent No. 7,674,240, issued to Webler et al., provides improved devices for inflating and deflating balloons for occluding a vessel.

Displacement of blood by means of introduction of another fluid to improve OCT imaging is conventionally done by a manual process, where the operator
5 injects the transparent fluid on one or more occasions during an imaging procedure. Such injection may be done via a number of methods, including use of a manual syringe, use of pressurized fluid delivery systems and use of powered pumps. Pressurized fluid delivery systems can include the simple use of gravitational forces to provide pressure, as well as devices that apply pressure
10 to a compressible or deformable compartment filled with the fluid of interest. For example, pressure infuser bags use an inflatable bladder, similar to that of a conventional blood pressure cuff, to apply pressure to a bag of fluid within a confined compartment. The inflatable bladder and the bag of fluid share a confined space. Therefore, when the bladder is inflated, such as with a manual
15 hand pump, pressurized infusions of fluid into a patient is possible.

Alternatively, blood can be displaced by use of a balloon filled with an optically clear medium, such as radio-opaque contrast, saline or air. The balloon may surround the region of the catheter where light, such as that used for OCT imaging or near infra-red (NIR) spectroscopy, exits the imaging probe.

20 Unfortunately, complications can arise when displacing blood from a vessel. For example, there is a small risk of embolic events, if the introduction of displaced fluid dislodges particles from the vessel wall. There is a risk of causing or worsening a dissection between the layers of the vessel wall if fluid is injected

inadvertently with too much force, or if the fluid is injected near a pre-existing dissection site. In critical organs such as the heart, the potential complications of displacing blood with another fluid include ischemia to the target organ and arrhythmias. Cardiac arrhythmias may occur as a result of hypoxia if the
5 displacing fluid does not carry adequate oxygen to the myocardium. They may also occur due to changes in the concentrations of electrolytes in the myocardium.

For vessels that perfuse critical organs sensitive to hypoxia, such as the heart, brain and kidneys, prolonged intervals of blood displacement and / or
10 vascular occlusion can lead to adverse clinical events, and the operator may be compelled to minimize the duration of time over which the displacement of blood occurs.

The need to minimize the amount of time during which blood is displaced has to be balanced with the desire to acquire an adequate amount of imaging
15 data. For example, if the imaging probe is translated along the vessel's longitudinal axis, the portion of the vessel adequately imaged by an optical imaging technique will be limited by the length of time during which blood is displaced adequately. Not only is the time duration over which blood is displaced of importance, but if an injection of an optically transmissive fluid is being used,
20 then the volume of fluid injected may have important consequences.

For example, some operators use radio-opaque contrast as the optically transmissive medium. Yet it is well known in the field of medicine that contrast agents frequently have deleterious effects on kidney function and can contribute

to acute renal failure. Conversely, inadequate displacement of blood results in sub-optimal imaging.

Variations of optical coherence tomography (OCT) include polarization sensitive OCT (PS-OCT) where the birefringent properties of tissue components
5 can be exploited to obtain additional information about structure and composition; spectroscopic OCT which similarly provides improved information regarding the composition of the imaged structures; Doppler OCT which provides information regarding flow and motion; elastography via OCT; and optical frequency domain
10 imaging (OFDI), which allows for a markedly more rapid acquisition of imaging data and therefore enables imaging to occur over a larger volume of interest in less time.

There exist several other forms of fiber-optic based imaging other than OCT. Amundson et al describe a system for imaging through blood using
infrared light (United States Patent No. 6,178,346). The range of the
15 electromagnetic spectrum that is used for their imaging system is selected to be one which optimizes penetration through blood, allowing optical imaging through blood similar to that afforded by angiography in the visible spectrum, but without the need to flush blood away from the region being imaged.

Tearney et al (U.S. Patent No. 6,134,003) describe several embodiments
20 that enable optical coherence tomography to provide higher resolution imaging than is readily obtained by high frequency ultrasound or IVUS.

Dewhurst (US Patent No. 5,718,231) discloses a forward looking probe for intravascular imaging where a fiber optic travels through an ultrasound

transducer to shine light on a target tissue straight in front of the end of the probe. The light then interacts with the target tissue and makes ultrasound waves, which are received by the ultrasound sensor and the images are photoacoustic images only as the system is not configured to receive and
5 process optical images. The ultrasound sensor used in the Dewhurst device is limited to thin film polymeric piezoelectrics, such as thin film PVDF, and is used only to receive ultrasound energy, not to convert electrical energy to ultrasound.

Angioscopy, endoscopy, bronchoscopy and many other imaging devices have been described which allow for the visualization of internal conduits and
10 structures (such as vessels, gastrointestinal lumens and the pulmonary system) in mammalian bodies based on the principle of illuminating a region within the body near the distal end of a rigid or flexible shaft. Images are then created by either having a photodetector array (such as a CCD array) near the end of the shaft or by having a bundle of fiber optics transmit the received light from the
15 distal end of the shaft to the proximal end where a photodetector array or other system that allows the operator to generate or look at an image representative of the illuminated region. Fiber bundles are bulky and reduce the flexibility of the shaft among other disadvantages.

Other fiber optic based modalities for minimally invasive assessment of
20 anatomic structures include Raman spectroscopy as described by Motz et al. (J Biomed Opt. 2006 Mar-Apr; 11(2)), near infrared spectroscopy as described by Caplan et al (J Am Coll Cardiol. 2006 Apr 18;47(8 Suppl):C92-6) and

fluorescence imaging, such as tagged fluorescent imaging of proteolytic enzymes in tumors (Radiology. 2004 Jun;231(3):659-66).

Recently, probe designs have emerged that combine multiple imaging modalities in a single device. Maschke (United States Patent Publication No. 5 2006/0116571 corresponding to U.S. Patent Application Serial No. 11/291,593) describes an embodiment of a guidewire with both OCT and IVUS imaging transducers mounted upon it. The described invention has several shortcomings. Guidewires are typically 0.014" to 0.035" in diameter (approximately 350 microns to 875 microns), yet ultrasound transducers typically 10 are at least 400 microns x 400 microns and generally are larger in size for the frequencies in the 20 to 100 MHz range. If the transducer is too small, the beam is poorly focused and has poor signal properties. In Maschke, the IVUS and OCT imaging mechanisms are located at different positions along the length of the guidewire, and a substantial drawback associated with this type of 15 configuration (having the IVUS and OCT imaging means located at different positions along the length of an imaging shaft) is that optimal co-registration of images is not possible.

Similarly, U.S. Patent No. 7,289,842 issued to Maschke describes an imaging system that combines IVUS and OCT on a catheter where the IVUS and 20 OCT imaging elements are longitudinally displaced from each other along the length of a catheter that rotates around its longitudinal axis. Maschke also describes generating images where the center portion of the images are substantially derived from the output of the higher resolution OCT imaging

portion of the system while the outer portion of the images are substantially derived from the output of the ultrasound imaging portion of the system, to make use of ultrasound's greater depth of penetration in combination with OCT's higher resolution for tissues close to the catheter.

5 U.S. Patent 6,390,978, issued to Irion, describes the use of high frequency ultrasound in combination with optical coherence tomography where the ultrasound beam and the OCT beam are superimposed on each other.

In U.S. Patent Application Publication No. 2008/0177138, Courtney et al. provide an improved multimodal imaging system incorporating both IVUS and
10 OCT transducers in a compact imaging assembly capable of side-viewing and / or forward-looking imaging. Such multimodal imaging systems offer the ability to obtain far greater diagnostic information than using a single modality imaging device. Indeed, optical coherence tomography generally has superior resolution to ultrasound and has the potential to better identify some structures or
15 components in vascular and other tissues than ultrasound. For example, fibrous cap thickness or the presence of inflammatory or necrotic regions near the surface of arteries may be better resolved with optical coherence tomography.

Unfortunately, many multimodal imaging devices suffer from problems related to incompatibility of one or more imaging modalities with blood. For
20 example, in the case of a multimodal imaging device combining both IVUS and OCT, the IVUS transducer is capable of functioning with the presence of blood in the vessel under investigation, but the OCT modality requires blood displacement. Such a requirement leads to complexity of operation and

difficulties in coordinating and referencing the results from the two imaging modalities.

Another problem with the use of multimodal imaging devices is the inaccuracies in co-registration that might result when one imaging modality is used, followed by another imaging modality after blood displacement. For example, intravascular imaging, such as IVUS and OCT, is often used for clinical trial purposes where an imaging protocol is required. Manually using one or more modalities to identify regions that should be assessed in greater detail by one or more other modality is subject to a substantial amount of operator variability. Furthermore, clinical studies that depend on the ability to compare the structure and/or composition of vessels between different patients or at different time points will be dependent on reproducible methods for assessment.

In US Patent No. 7,758,499, Adler teaches the use of IR imaging with wavelengths of less than 1000 nm, which is minimally compromised by the presence of blood, in combination with other imaging modalities, such as imaging with visible light. To achieve multimodal optical imaging, blood displacement methods are employed, enabling imaging with IR and / or visible light.

The use of multiple imaging modalities in a single imaging device was also recently described by Muller et al. (US Patent Application Publication No. 2009/0299195). Muller describes methods and systems for combining intravascular ultrasound, optical coherence tomography, and near infrared spectroscopy for the detection of multiple, different abnormalities in the arterial morphology during a single intravascular procedure.

Unfortunately, the known methods employing manual operations for serially acquiring multimodal images require considerable skill and further involve complex image spatial alignment operations. Accordingly, there remains a need for multimodal imaging methods that address the aforementioned problems, 5 enable standardized image data acquisition, and provide improved performance and clinical utility.

SUMMARY

Embodiments of the present disclosure provide systems and methods for 10 improving the ability to identify and/or collect data from vessels and other tissues with intraluminal probes capable of collecting data using two or more imaging modalities, where one or more imaging modalities are capable of collecting data through an intraluminal medium (such as blood) and one or more other modalities function with improved performance when the intraluminal medium is 15 at least partially displaced from the field of view.

In one aspect, there is provided a method of directing a medium displacement operation for performing a minimally invasive procedure within a lumen or cavity, the method comprising the steps of: recording a first set of images obtained from a first imaging modality when a first translation operation of 20 a functional component of an imaging probe is performed; spatially correlating the first set of images with an associated position of the functional component of the imaging probe, wherein the first imaging modality is compatible with a presence of a displaceable medium; processing the first set of images and identifying a region of interest; and directing a medium displacement operation

while a second translation operation of the functional component of the imaging probe is performed over the region of interest; wherein the minimally invasive procedure is performed within the region of interest during the medium displacement operation.

5 In another aspect, there is provided a method of directing a medium displacement operation for performing a minimally invasive imaging procedure within a lumen or cavity, the method comprising the steps of: a) obtaining one or more images from a first imaging modality of an imaging probe, wherein the first
10 imaging modality is compatible with a presence of a displaceable medium; b) processing the one or more images to identify a region of interest; and c) if a
15 region of interest is identified, directing a medium displacement operation and performing a minimally invasive procedure while the medium displacement operation is performed.

 In another aspect, there is provided a method of directing a medium
15 displacement operation for performing a minimally invasive procedure within a lumen or cavity with a probe, the method comprising the steps of: obtaining, with an external imaging apparatus, one or more images of a region within which the minimally invasive procedure is to be performed; identifying a region of interest within the one or more images; translating a functional component of the probe to
20 the region of interest while obtaining one or more additional images with the external imaging apparatus, wherein a position of the functional component is identifiable in the one or more additional images; and directing a medium displacement operation while performing a translation operation associated with

the functional component of the probe within the region of interest.

In another aspect, there is provided a method of directing a medium displacement operation for performing a minimally invasive procedure within a lumen or cavity, the method comprising the steps of: recording a set of
5 measurements obtained from a non-imaging modality when a first translation operation of a functional component of a probe is performed; spatially correlating the set of measurements with an associated position of the functional component of the probe, wherein the non-imaging modality is compatible with a presence of a displaceable medium; processing the set of measurements and identifying a
10 region of interest; and directing a medium displacement operation while a second translation operation of the functional component of the probe is performed over the region of interest; wherein the minimally invasive procedure is performed within the region of interest during the medium displacement operation.

In another aspect, there is provided a method of directing a medium
15 displacement operation for performing a minimally invasive imaging procedure within a lumen or cavity, the method comprising the steps of: a) obtaining one or more measurements from a non-imaging modality of a probe, wherein the non-imaging modality is compatible with a presence of a displaceable medium; b) processing the one or more measurements to identify a region of interest; and c)
20 if a region of interest is identified, directing a medium displacement operation and performing a minimally invasive procedure while the medium displacement operation is performed.

A further understanding of the functional and advantageous aspects of the disclosure can be realized by reference to the following detailed description and drawings.

5

BRIEF DESCRIPTION OF THE DRAWINGS

Embodiments will now be described, by way of example only, with reference to the drawings, in which:

Figure 1 is a block diagram illustrating a system for performing multimodal imaging.

10

Figure 2 is a block diagram illustrating a second system for performing multimodal imaging incorporating an integrated medium displacement system.

Figure 3 is a perspective drawing showing an example of a multimodal imaging system incorporating both intravascular ultrasound (IVUS) and optical coherence tomography (OCT), showing a flexible imaging probe with a

15

connector, conduit and imaging assembly;

Figure 3(a) is a cross sectional view of the mid-section of the imaging probe of Figure 1 taken along the dotted line;

Figure 3(b) is an expanded perspective drawing of the distal region of the imaging probe of Figure 1;

20

Figure 3(c) shows a schematic of how the rotary and non-rotary components of the imaging probe can be coupled with an adapter to the rest of an imaging system.

Figure 3(d) is a perspective drawing of an example of the coupling of the

rotary and non-rotary components of the probe to an adapter.

Figure 4(a)-(d) illustrates the distal end of an imaging probe that is capable of both acoustic and optical imaging where a tiltable deflecting surface can change the imaging angle as a function of the rotational velocity of the
5 imaging assembly.

Figures 5 (a) and (b) illustrates an example of a side-viewing multimodal imaging assembly comprising an ultrasound transducer and an optical fiber for combined co-planar IVUS and OCT imaging.

Figure 6 is a flow chart describing a method of performing a minimally
10 invasive procedure in which results obtained from a first imaging modality are employed to direct the acquisition of images using a second imaging modality that benefits from displacement of an intraluminal medium.

Figure 7 is a flow chart describing a method of performing a minimally
15 invasive procedure in which results obtained from a first imaging modality are employed in real time to direct the acquisition of images using a second imaging modality that benefits from displacement of an intraluminal medium.

Figure 8 is a block diagram illustrating a system for performing multimodal imaging incorporating an integrated medium displacement system and an
external imaging apparatus.

20

DETAILED DESCRIPTION

Various embodiments and aspects of the disclosure will be described with reference to details discussed below. The following description and drawings are

illustrative of the disclosure and are not to be construed as limiting the disclosure. Numerous specific details are described to provide a thorough understanding of various embodiments of the present disclosure. However, in certain instances, well-known or conventional details are not described in order to provide a
5 concise discussion of embodiments of the present disclosure. It should be understood that the order of the steps of the methods disclosed herein is immaterial so long as the methods remain operable. Moreover, two or more steps may be conducted simultaneously or in a different order than recited herein unless otherwise specified.

10 As used herein, the terms, “comprises” and “comprising” are to be construed as being inclusive and open ended, and not exclusive. Specifically, when used in the specification and claims, the terms, “comprises” and “comprising” and variations thereof mean the specified features, steps or components are included. These terms are not to be interpreted to exclude the
15 presence of other features, steps or components.

As used herein, the term “exemplary” means “serving as an example, instance, or illustration,” and should not be construed as preferred or advantageous over other configurations disclosed herein.

20 As used herein, the terms “about” and “approximately”, when used in conjunction with ranges of dimensions of particles, compositions of mixtures or other physical properties or characteristics, are meant to cover slight variations that may exist in the upper and lower limits of the ranges of dimensions so as to not exclude embodiments where on average most of the dimensions are satisfied

but where statistically dimensions may exist outside this region. It is not the intention to exclude embodiments such as these from the present disclosure.

As used herein, the term “high resolution imaging” refers to high resolution
5 imaging methods including, but not limited to, ultrasound and optical imaging.
“High frequency ultrasound” as used herein refers to ultrasound imaging with
frequencies of greater than about 3 MHz, and more typically in the range of 8 to
200 MHz.

As used herein, the term “imaging energy” refers to light or acoustic
10 energy or both. Specifically, “light” and/or “optical” refers to electromagnetic
waves with one or more wavelengths that may reside within in the ultraviolet,
visible, near infra-red and/or infrared spectrum.

As used herein, the term “image analysis”, , generally refers to the
processing of image data to identify regions of interest, where the regions of
15 interest general pertain to one or more images or portions thereof that may be of
relevance.

As used herein, the terms “translation” and “translation operation”, when
associated with an intraluminal probe such as an imaging probe, refer to the
translation of at least a portion of the probe, such that a functional portion of the
20 probe is translated relative to a lumen in which the probe is located. An example
of a functional portion of a probe is an imaging assembly. A translation operation
may involve translating a functional portion of a probe relative to another portion
of a probe, such as an external sheath.

Embodiments of the present disclosure provide systems and methods for performing improved imaging during a minimally invasive procedure using a multimodal imaging catheter-based device for which least one imaging modality benefits from the displacement of intraluminal fluid during imaging. Specific
5 embodiments provide standardized and/or automated systems and methods for selecting regions within a lumen for a subsequent imaging step involving the displacement of an intraluminal medium.

In one embodiment, a multimodal imaging system is provided that includes at least one imaging modality compatible with imaging in an intraluminal
10 medium, and at least one imaging modality for which imaging performance is improved following the displacement of the intraluminal medium. Referring to Figure 1, a block diagram is shown illustrating an example embodiment of a multimodal imaging system 100. The imaging probe 105, which is contained within a lumen that is deliverable to an anatomic structure 102 (for example, a
15 lumen or blood vessel), includes an imaging assembly 110 near its distal end 115, an optional imaging conduit 120 along a substantial portion of its length, and a connector 125 at its proximal end 130.

Imaging assembly 110 generally refers to the component of the imaging probe 105 from which the multimodal signals (for example, acoustic and optical)
20 are transmitted and/or collected when imaging a region that is proximate to the imaging assembly 110. Multimodal imaging assembly 110 includes components and devices for imaging using two or more imaging modalities. Imaging assembly 110 may include imaging transducers, detectors, and/or imaging energy coupling

devices. Imaging energy for irradiating tissue in the vicinity of the probe according to a given imaging modality may be produced by one or more transducers housed within imaging assembly 110, and/or may be produced external to the imaging probe by one or more external transducers and delivered
5 through an energy guiding device (such as a fiber optic or optical waveguide) through the imaging conduit 120 to imaging assembly 110. Similarly, incident imaging energy produced or scattered within tissue to be imaged and relating to a given imaging modality may be received by a detector housed within imaging assembly 110, or may be received within imaging assembly and coupled to an
10 external detector through an imaging energy guiding device within imaging conduit 120. Imaging couplers and related energy guiding devices may support one or more imaging modalities. For example, a fiber optic and lens or mirror assembly may be employed for the delivery of imaging energy related to both OCT and IR imaging modalities. Imaging energy associated with two or more
15 imaging modalities may be produced and/or received by a common energy producing and/or receiving apparatus and mutually multiplexed in frequency or interleaved in time. Imaging probe 105 may be rotatable or may contain a rotating imaging element for achieving a radial field of view within a lumen.

In embodiments in which at least one imaging modality is optical imaging,
20 the imaging assembly 110 typically contains the distal tip of a fiber optic, as well as a combination of optional optical components such as a lens (such as a ball lens or gradient refractive index lens, also known as a GRIN lens), which collectively serve the purpose of acting as an optical receiver, (a collection

element for collecting optical energy from the tissue to be imaged) and may also serve as an optical emitter (a focusing and/or beam directing element for focusing and/or directing an emitted optical beam into the tissue to be imaged). A mirror and/or a prism are often incorporated as part of an optical emitter and/or receiver. The imaging assembly 110, connector 125 and/or imaging conduit 120 may be immersed in fluid, such as saline. For multimodal optical and acoustic imaging, imaging probe 105 may be compartmentalized such that there is at least one gas-filled compartment or lumen for optical imaging and at least one fluid-filled compartment or chamber for acoustic imaging.

10 The imaging conduit 120 typically includes at least one optical waveguide or at least one conductive wire (optionally two or more) that connects an emitter and/or receiver via connector 125 to adapter unit 140. Imaging conduit 120 may also act as a mechanical force transmission mechanism for rotating or translating the imaging assembly. For example, imaging conduit 120 may include a fiber
15 optic, wrapped by two layers of electrical wire that are insulated from each other. Imaging conduit 120 may be further reinforced by other structural features, such as helically wrapped wires or other designs used to construct imaging torque cables for rotating scan mechanisms, as described known to those skilled in the art. Imaging conduit may also supply power to a micro-motor located in the distal
20 end of imaging probe 105 for locally rotating one or more components of imaging assembly 110.

Figure 3 provides a perspective drawing of an example embodiment of a multimodal imaging probe that may be employed as a component of a

multimodal imaging system according to embodiments of the disclosure. The probe shown in Figure 3 was disclosed in US Patent Application No. 10/010,206, titled "Scanning Mechanisms for Imaging Probe" filed on January 22, 2008, and US Patent Application No. 12/385,014, titled "Scanning Mechanisms for Imaging
5 Probe" and filed on March 27, 2009, the contents of which are incorporated herein by reference in their entirety. Briefly, the imaging probe may include an imaging assembly, where the imaging assembly includes a movable member that is capable of directing in imaging energy beam at one or more angles in a forward-looking direction. In two non-limiting example implementations, the
10 orientation of the movable member may be varied by changing the rotational velocity of the imaging assembly upon which the movable member is pivotable, or using a magnetic force or actuation means.

The example imaging probe incorporates both ultrasound (e.g. IVUS) and optical (e.g. OCT) modalities into a single catheter assembly for multimodal
15 imaging. The system includes a flexible catheter containing a fiber optic 40 and a co-axial electrical wire 50. The proximal connector contains fiber optic 40 that can be received by the adapter to optically couple the imaging fiber optic 40 to the optical imaging system "back-end". There are also electrical connectors 56 that allow the one or more electrical conduits to be connected to the electronic or
20 power circuitry and/or controller and processing units, such as those for an ultrasound processing system.

The imaging conduit of the present example rotates around its longitudinal axis, and the coupling of a rotating fiber optic probe can be

accomplished using a fiber optic rotary joint incorporated either as part of the proximal connector of the imaging probe 10 or as part of the adapter 14.

Similarly, conductive wires that rotate with the imaging conduit are coupled with relatively stationary conductors of the ultrasound circuitry and/or controller and
5 processing units, for example, by means of slip rings or rotary transformers.

These slip rings can be incorporated as part of the proximal connector of the imaging probe 10 or as part of the adapter 14.

Figure 3(a) shows a cross sectional view of the midsection of the imaging probe of Figure 3 taken along the dotted line which shows a fiber optic 40, guide
10 wire port 44 and guide wire 42, imaging conduit 34, imaging conduit lumen 46, external sheath 48 which is a hollow, flexible elongate shaft made of a physiologically compatible material and having a diameter suitable to permit insertion of the hollow elongate shaft into bodily lumens and cavities, and coaxial electrical wiring 50.

15 The imaging probe may contain ports at one or more points along its length to facilitate flushing. The expanded detailed view of the end of the imaging probe 10 shown in Figure 3(b) shows the distal end of the guidewire 42 extended beyond the end of the outer sheath 48 and a flush port 54 at the end of the sheath 48.

20 As shown in Figure 3, the proximal end of the imaging probe 10 includes a guide wire port 55 into which guide wire 42 is inserted and the connector assembly 36 which includes a flush port 58 and electrical contacts 56 along the connector body.

Figure 3(c) shows a schematic of how the rotary and non-rotary components of the imaging probe can be coupled with an adapter to the rest of an imaging system. Figure 3(d) schematically shows how the rotating components of the imaging probe can be coupled to the rotating components of an adapter. The rotating components of each can be electrically, optically and/or mechanically coupled using connectors and other configurations known in the art. Similarly, the non-rotating components of the imaging probe can be coupled to the non-rotating components of the adapter 14. The adapter 14 can include slip rings, rotary transformers, optical rotary joints and other such implements for electrically or optically coupling a rotary component to a non-rotary component and enable communication of necessary electrical and optical signals with the rest of the system.

Dual-fiber optical rotary joints are also available but considerably more complex. Electrical coupling between any conductor mounted onto a rotating component in the imaging probe 12 can be coupled to non-rotating conducting elements via metallic slip rings and springs, metallic slip rings and brushes or other commonly known methods of forming conductive contact between a stationary conductor and a rotary conductor.

While the electrical, optical and mechanical connections are shown separately in Figure 3(d), it is possible to reduce the several connectors that must each be separately connected between the probe and adapter with fewer connectors by combining several connectors into combined connectors, as needed for a specific embodiment.

Figure 4 provides an example of the internal structure of the distal end of the imaging probe that incorporates a multimodal imaging assembly. The assembly includes a tiltable component 70 for deflecting imaging energy that is emitted and/or received by one or more components that are not attached
5 directly to the tiltable component 70. An ultrasound transducer 88 and optical emitter 92 are provided for directing imaging energy towards the tiltable component 70. The imaging energy is then deflected by an energy deflecting component mounted on the tiltable component 70. For ultrasound imaging, the energy deflecting component (the tiltable component 70) may include an
10 acoustically reflective surface, such as a solid metal surface (e.g. stainless steel) or crystalline surface, such as quartz crystal or glass or a hard polymer.

For optical imaging, the energy deflecting component (tiltable component 70) may include an optically reflective surface such as a mirror surface made from polished metal, metallized polymer such as metallized biaxially oriented
15 polyethylene terephthalate (Mylar), sputtered or electrochemically deposited metal, metal foil or other reflective components such as thin film reflectors. Metals commonly used to make mirrors include aluminum, silver, steel, gold or chrome.

An example embodiment of a distal end 29 of an imaging probe 31 is
20 shown in Figure 4(a), in which the distal end contains an imaging assembly 30 that includes a tiltable component 70 where the tiltable component is a disc mounted on pins 72 that enable the disc 70 to pivot about a pin.

The pins 72 define the tilting axis of the tiltable disc 70. When the imaging

assembly 30 is at rest, the disc 70 will remain in an arbitrary starting position. In the example shown, this starting position is defined by a stop 80 that corresponds to a maximal imaging angle, where a restoring force providing by a torsion spring 76 is pushing the disc 70 towards the aforementioned stop 80 .

5 Figure 4(b) shows a cross section along hashed vertical line 2(c) – 2(c) of Figure 4(a).

If the tiltable component 70 is tilted away from its preferred orientation by an external force, such as gravity, magnetic forces, electrostatic forces, friction with another moving part or fluid, compressive forces, cantilever forces, normal
10 forces or any other source of incompletely opposed torque on the tiltable component 70 around the tilt axis, the tilt angle will increase.

One or more stops 80 and 82 may limit the range of the tilt angle of the tiltable component 70. For example, stop 80 may be a post or lip extending from the shell 84 of the imaging assembly 30 as a stop to prevent the tilting
15 component 70 from further changing its tilt angle while it makes contact with the stop 80. Therefore, the stop can be used to limit the tilt angle from exceeding a maximum value determined by the position of the stop. Once the tilt angle hits this maximum, the normal force exerted by the stop 80 on the tiltable component 70 opposes the restoring mechanism. In many embodiments, this maximum tilt
20 angle is the tilt angle that is achieved when the imaging assembly 30 is at rest and at low rotational speeds.

An additional or alternative stop 82 can be included to create a minimum tilt angle that the tiltable component 70 will achieve at rotational speeds in the

upper end of the operating range. Indeed, there are many situations in which there is no significant benefit in allowing the tilt angle to reach zero, as will become apparent in the following descriptions of specific embodiments.

Imaging assembly 30 may include one or more mechanisms that tend to
5 cause the tiltable component 70 to have its tilting angle increase. For the purposes of this disclosure, such a mechanism is referred to as a restoring mechanism. The torsion spring 76 (as shown in Figure 4(a) and 4(c)) or a compression spring can be used as a restoring mechanism, where one end of the spring 76 is mechanically in contact with or coupled to the tiltable component
10 70 . The other end is mechanically coupled to another part of the imaging probe 31, such as the body of the imaging assembly.

As the imaging assembly 30 rotates, the disc 70 will want to align itself such that the normal of the planes defined by the faces of the disc 70 are substantially parallel with the longitudinal axis. As seen in Figure 4(c), the other
15 stop 82 shown (which corresponds to a minimum imaging angle) will prevent the disc 70 from reaching its preferred orientation at high rotational speeds of the imaging assembly. With a suitably configured imaging assembly, the stop 82 that corresponds to a minimum imaging angle can correspond to an angle of zero, providing imaging in a direction parallel to the longitudinal axis of the imaging
20 probe.

Another example of a multimodal imaging assembly for use in a multimodal imaging system is provided in Figure 5, as taught in US Patent Application No. 12/010,208, titled "Imaging Probe with Combined Ultrasound and

Optical Means of Imaging”, filed on January 22, 2008 by Courtney et al., which is incorporated herein by reference in its entirety. Referring to Figure 5(a), an imaging assembly 550 is provided which is configured to allow imaging by acoustic and optical means in the same direction, so that an acoustic transducer that allows light energy to travel through a channel in the transducer is utilized. Essentially, assembly 550 uses an acoustic transducer 502 that is altered to have an optically transmissive channel made through its substrate. The acoustic transducer 502 can be any kind of ultrasound transducer known in the art, such as piezoelectric composition (e.g. PZT or PVDF, single crystal piezoelectric), a composite transducer or a capacitive micromachined ultrasonic transducer (cMUT)..

Electrical conductors 500 are directed to the conducting layers 501 on either side of the transducer's acoustic substrate 502. A fiber optic 503 provides an optical conduit for enabling optical imaging. One or more matching layers can be added to the emission surfaces of the transducer, such as an epoxy layer (such as a silver or copper conductive epoxy layer which may functionally also serve as one or both of the electrodes that drives the transducer), or a polymer (such as parylene or PVDF).

Conductive layers 501 on either side of the piezoelectric material 502 are incorporated as required for applying a voltage to the piezoelectric. The opening 507 is coupled to an optical waveguide 503, either directly, or by means of one or more mirrors or prisms and one or more lenses (not shown). If any optical components are included within the opening, a dampening, insulating layer of a

compliant material 506, such as silicon or polymer may separate the optical components from the acoustic substrate 502 to act as either an electrical insulator or to minimize the transmission of stresses that are generated by the acoustic substrate 502 to the optical components.

5 As shown in Figure 5(b), the light from the fiber can be directed towards a mirror 404 (or prism) that causes the light from the fiber to be deflected through the optically transmissive channel 507.

 Yet another non-limiting example of a multimodal imaging system is provided in Figure 1 of US Patent Publication No. 2009/0299195, titled
10 “Multimodal Catheter System and Method for Intravascular Analysis”, and filed by Muller et al., of which only Figure 1 is incorporated herein by reference . The system combines intravascular ultrasound, optical coherence tomography, and near infrared spectroscopy for the detection of multiple, different abnormalities in the arterial morphology during a single intravascular procedure.

15 The above examples illustrate multimodal imaging systems, which may be adapted according to embodiments of the present disclosure as described below. It is to be understood that the preceding examples were merely provided as a non-limiting examples, and that other multimodal imaging probes may also be used with embodiments of the present disclosure.

20 Referring again to Figure 1, multimodal imaging system 100 is configured for the displacement of an intraluminal medium during a non-invasive procedure to support an imaging modality that benefits from the displacement of intraluminal medium during imaging. Such displacement may be provided and controlled by

one of many devices and subsystems, including, but not limited to, subsystems for displacement of intraluminal medium through intraluminal flushing, and subsystems for displacement of intraluminal medium through controlled occlusion of the lumen., as taught in US Patent Publication No. 2009/0299195 and US
5 Patent No. 7,758,499, titled "Method and Apparatus for Viewing Through Blood", which is incorporated herein by reference in its entirety.

In one embodiment, intraluminal flushing may be achieved by providing flushing liquid to the imaging probe 105 through an input port, whereby the flush liquid is dispensed into the lumen via output ports provided at one or more points
10 along the length of imaging probe. Alternatively, flushing liquid may be provided via a conventional guide catheter that is able to introduce fluid into the lumen to be imaging. Alternatively, flushing liquid may be provided via a specialized flush catheter, for example, as disclosed in US Patent No. 7,625,366, titled "Flush Catheter with Flow Directing Sheath", which is incorporated herein by reference
15 in its entirety. Flushing liquid, such as a saline solution, Ringer's lactate solution or contrast agent, may be provided manually, for example, using an external syringe. In some example embodiments, flushing may be performed via an auto-injector, pressure infuser bag, a peristaltic pump, a syringe or piston pump, a valved system, a gravity pressurized system, and the external application of
20 pressure to medium using automated or manual application of pressure.

In one embodiment, medium displacement apparatus, shown generally at 135, provides and/or regulates or controls one or more medium displacement operations. As noted above, medium displacement apparatus 135 may be

interfaced with imaging probe 105, or may be provided as a separate apparatus (such as a guide catheter or specialized flush catheter) for achieving medium displacement. In a non-limiting example, medium displacement apparatus 135 may include an external pump (not shown) that provides controlled volumes of flush solution (from a reservoir) to a region of interest. In another example, 5 medium displacement apparatus 135 may include an inflatable balloon housed on or within imaging probe 110 for achieving medium displacement by controlled inflation that results in full or partial occlusion of the lumen.

In another embodiment, medium displacement apparatus 135 may further 10 include an external manual switch that only enables or authorizes automated displacement operations when the switch is activated by a user or physician. Such a switch enables a supervisory mode of semi-automated medium displacement, requiring that a human operator is actively involved in monitoring any automated displacement operations. Non-limiting examples of suitable 15 switches include a button or a foot pedal that must be continuously depressed for automated displacement (e.g. injection or inflation) to take place.

Referring again to Figure 1, driver and adapter unit 140 includes interfaces for facilitating transmission of power and/or signals within any fibers and/or wires between imaging probe 105 and the appropriate control and/or processing 20 subsystems. It may include a motor driver subsystem 145 for imparting rotation motion to rotary components of the imaging probe. Motor drivers may also power a pullback mechanism, push-forward mechanism or a reciprocating push-pull mechanism to facilitate longitudinal translation of imaging assembly 110. Such

longitudinal translation of imaging assembly 110 may occur in conjunction with the longitudinal translation of an external shaft (not shown) that surrounds the image assembly 110 and imaging conduit 120, or may occur within a relatively stationary external shaft.

5 Additional sensor subsystems may be incorporated as components of the driver and adapter unit 140, such as a position sensing subsystem 150, for example to sense the angle of rotation of a rotary component within imaging probe 110 and/or the longitudinal position of imaging assembly 110. Imaging probe 110 may also include a memory component such as an EEPROM or other
10 programmable memory device that includes information relating to imaging probe 110 such as, for example, identifying specifications of imaging probe 110 and/or calibration information. Additionally, driver and adapter unit 140 may further include amplifiers 160 to improve the transmission of electrical signals or power between imaging probe 110 and the rest of the system.

15 Driver and adapter unit 140 is interfaced with control unit 165. Control unit 165 includes first 170 and second 175 imaging modality controller subsystems to support the multimodal imaging devices (the system may further include additional imaging modalities and controllers in addition to the two shown), which may include, but are not limited to, any of the following imaging modalities: 1)
20 ultrasound, 2) optical coherence tomography, 3) angioscopy, 4) infrared imaging, 5) near infrared imaging, 6) Raman spectroscopy-based imaging and 7) fluorescence imaging.

While the first and second imaging modality controllers are shown as

separate subsystems, it is to be understood that they may be one and the same. For example, OCT and near infra-red (NIR) spectroscopy data can conceivably be acquired via a common light source and signal acquisition system. Similarly, when the first and second modalities are both IVUS, with one modality being a
5 lower frequency IVUS than the other, the hardware required to generate and acquire the two sets of IVUS data may be the same, with different operating parameters.

An optical modality controller may include any or all of the following components: interferometer components, one or more optical reference arms,
10 optical multiplexors, optical demultiplexers, light sources, photodetectors, spectrometers, polarization filters, polarization controllers, timing circuitry, analog to digital converters and other components known to facilitate any of the optical imaging techniques described herein or incorporated herein by reference.

An ultrasound modality controller may include any or all of the following
15 components: pulse generators, electronic filters, analog to digital converters, parallel processing arrays, envelope detection, amplifiers including time gain compensation amplifiers and other components known to facilitate any of the acoustic imaging techniques described herein or incorporated herein by reference. Control unit 165 may include one or more of the following non-limiting
20 list of subsystems: a motor drive controller 180, position sensing control circuitry 190, timing circuitry, volumetric imaging processors, scan converters and others.

As shown in Figure 1, medium displacement apparatus 135 may be operated and/or controlled independent of control unit 165. For example, medium

displacement apparatus 135 may include a syringe or a manual pump. In another embodiment, shown in Figure 2, control unit 165 may further includes medium displacement controller 185, which monitors medium displacement operations and may also automate or semi-automate medium displacement operations. In
5 an alternate embodiment, medium displacement controller 185 may be directly interfaced with medium displacement apparatus 135. Medium displacement controller 185 may monitor information including, but not limited to, a volume of flush solution provided for a given medium displacement operation, a total of flush solution provided for multiple medium displacement operations for a given
10 patient and/or minimally invasive procedure, a time duration during which a given medium displacement operation is carried out, a total time duration over which multiple medium displacement operations are carried out for a given patient and/or minimally invasive procedure, and control signals and/or commands communicated to a device or subsystem for achieving medium displacement.

15 Medium displacement controller 185 may provide input to a feedback loop employed during control of a sequence of imaging and displacement operations coordinated by processing unit 205, as further described below.

Control unit 165 may further include an optional cardiac sensor controller 195 for controlling optional cardiac sensors 200, such as electrode sensors to
20 acquire electrocardiogram signals from the body of the patient being imaged. The electrocardiogram signals may be used to time the acquisition of imaging data in situations where cardiac motion may have an impact on image quality. The electrocardiogram may also serve as a trigger for when to begin an acquisition

sequence, such as when to begin changing the speed of rotation of a motor in order to cause a desired scan pattern to take effect. For example, ECG-triggered initiation of an imaging sequence may enable images to be acquired during a particular phase of the cardiac cycle, such as systole or diastole. The electrocardiogram signals optionally serves as a trigger for varying the rate of injection or inflation of the medium displacement system to allow the system to account for the pulsatile nature or blood flow under observed physiological conditions.

Control unit 165 is interfaced with processing unit 205, which includes a processor 210 and memory and/or storage subsystem 215 connected by a bus, and performs multiple processing functions for coordinating various aspects of system operation. It is to be understood that although control unit 165 and processing unit 205 are shown as distinct subsystems, they may be provided in a composite computing system 220. Furthermore, some or all of the elements of control unit 165 may be performed by processing unit 205. Furthermore, processor 210 may include several processing elements, such as one or more CPUs, field programmable gate arrays, GPUs, ASICs, DSP chips and other processing elements known in the art. Processing unit 205 may also be interfaced with display and user interface 225 for either real time display or display of data at a time later than the time at which imaging data is acquired.

Imaging system 100 may further include data storage components (such as memory, hard drives, removable storage devices, readers and recorders for portable storage media such as CDs and DVDs), which may be interfaced with

components of the processing unit and/or control unit.

In one embodiment, processing unit 205 is programmed to analyze images obtained using a first imaging modality, and to utilize the imaging results to automate the recording of images based on a second imaging modality that
5 requires or benefits from an intraluminal medium displacement operation during image acquisition. The first imaging modality may be compatible with intraluminal medium, such that it does not require an intraluminal displacement operation to images with sufficient diagnostic sensitivity or clinical utility.

In an embodiment in which the intraluminal liquid is blood, the first imaging
10 / detection modality may be selected from the non-limiting list including grayscale IVUS, radio-frequency IVUS (e.g. Virtual HistologyTM, integrated backscatter or iMapTM), elastography, NIR spectroscopy, sono-luminescent imaging, microbubble enhanced IVUS, targeted microbubble enhanced IVUS, photo-acoustic imaging, fluorescence spectroscopy, biosensors such as ion-selective
15 field effect transistors, and the second imaging modality may be selected from the non-limiting list including OCT, angioscopy, NIR spectroscopy, Raman spectroscopy, IVUS, radio-frequency IVUS, elastography, sono-luminescent imaging, microbubble enhanced IVUS, targeted microbubble enhanced IVUS, fluorescence spectroscopy, and photo-acoustic imaging. A second imaging
20 modality that is optical in nature may utilize wavelengths from the ultraviolet, visible, NIR, and/or infrared portions of the electromagnetic spectrum.

In another embodiment, the first and second imaging modalities may be a single imaging modality, for which images may be initially obtained in the

presence of an intraluminal medium, and where improved images may be subsequently obtained via a displacement operation.

Even though ultrasound has reasonable penetration through blood, the displacement of blood from the field of view of an ultrasound imaging probe can still improve the ability to identify the wall of a vessel or provide improved image contrast. Meanwhile, ultrasound has the ability to better penetrate through biological media such as blood and soft tissues and has a depth of penetration that typically extends several millimeters or centimeters beyond that of optical coherence tomography.

In one example embodiment, the first and second imaging modalities are both IVUS, but the first modality is IVUS having a lower frequency range than the second IVUS modality. Generally speaking, higher frequencies of ultrasound provide higher resolution than lower frequencies, but higher frequencies do not penetrate through blood as well. Therefore, it may be desirable to displace blood when imaging with higher frequencies of IVUS. There may be separate ultrasound transducers for the two IVUS imaging frequencies, or the ultrasound transducers may have a wide enough bandwidth to be able to support two or more imaging frequencies, where the imaging frequencies are dictated in part by the frequency of the pulses used by a pulser to excite the ultrasound transducer.

The ability to combine ultrasound with optical imaging methods, such as OCT or near infrared spectroscopy using a single imaging probe, provides advantages with respect to selecting the required resolution and depth of penetration. Furthermore, much of the information acquired by optical coherence

tomography is complementary to that acquired by ultrasound and analysis or display of information acquired by both imaging methods would improve the ability to better understand the interrogated tissue, such as with respect to its composition.

5 It should be noted that while intravascular OCT is significantly impeded by the presence of blood, NIR spectroscopy is less affected and is able to assess plaque composition up to a distance of a few millimeters through blood. However, it will be less effective in larger vessels and aneurysmal segments of otherwise normal-calibre vessels.

10 Referring to Figure 6, a flow chart is provided that illustrates an embodiment in which images recorded using a first imaging modality are employed to direct a displacement operation when subsequently obtaining images from a second imaging modality, where the second imaging modality is impeded by the presence of a displaceable intraluminal medium.

15 In step 300, a multimodal imaging probe, such as imaging probe 105 in Figure 1, is inserted into a lumen for obtaining images with a first imaging modality that is compatible with the presence of a displaceable intraluminal medium. A first imaging operation, which may be a translation operation such as a pullback, is performed while recording imaging data using the first imaging
20 modality. The translation operation may be automated and performed at a constant translation rate that is selected and/or optimized for the first imaging modality. Signals obtained from the first imaging modality device (located in imaging assembly 110 of imaging probe 105) during the first translation operation

are provided to first imaging modality controller 170.

According to the present embodiment, position sensing is employed during the translation operation to identify the location of the recorded images relative to a reference position and optionally a reference orientation. The recorded images are therefore correlated with the position, and optionally the orientation, of the imaging probe. Position sensing may be achieved using one of many known methods, and is generally represented in Figure 1 by position sensor 150 and position sensing controller 190 (which may together form a composite subsystem).

In one embodiment, position sensing is obtained by intraluminal longitudinal position sensing, for example, using encoders or other position sensors connected to the imaging probe, pullback motor or drive element. Position sensing may be obtained via spatial domain measurements, or inferred based on time-domain measurements in which translational or rotatory motion is performed at known rates. For example, position information relating to the longitudinal position of an imaging probe may be inferred based on a time interval over which translation occurs, provided that the rate of change of the position of the image probe is known during the time interval. The rate of change of position may be constant during probe translation. Angular orientation sensing may be obtained using rotary encoders or other position sensors connected to the imaging probe, as taught in co-pending US Patent Application No. 12/010,207, titled "Medical Imaging Probe with Rotary Encoder" and filed on January 22, 2008, which is incorporated herein by reference in its entirety.

In another embodiment, position sensing may be achieved using a sensing element located in the imaging probe that determines the location of the imaging probe in an externally created field, such as a magnetic field, which may be performed in combination with orientation sensing. A suitable sensor is
5 provided by Mediguide Ltd., and may be employed as taught by Muller et al. in US Patent Application Publication No. 2009/0299195.

After having performed a first translation operation, image data from first imaging modality controller 170 is provided to processor 210 for image analysis in step 305. Processor 210 analyzes the image data according to an image
10 processing algorithm to identify regions of interest, such as regions of diagnostic, research, and/or clinical interest. Regions identified may represent a wide range of anatomical structures and/or features, including, but not limited to, a desired tissue type for subsequent analysis, specific anatomical features, known or suspected pathological structures or features, and medical implants or
15 other artificial structures. Suitable regions of interest include the following non-limiting list: plaque, possible thrombus, branch points, lesions, calcifications, implants such as stents or brachytherapy implants, stenoses, areas of vessel wall thickening, lipid cores, necrotic regions, fibrous caps, dissections, masses and the like. Regions of interest may further include regions with microbubbles
20 detected, such as targeted microbubbles. They may also include regions of indeterminate or uncertain structure or composition, where an automated or semi-automated processing algorithm cannot confidently assess the region of interest without further imaging data.

Regions of interest may further include vascular lesions that have not led to clinical symptoms, but are at increased risk of rupturing or eroding and causing an acute myocardial infarction. These so-called “vulnerable plaques” are an area of interest as the prospect of treating such plaques to pre-empt adverse clinical events is conceptually appealing.

In another embodiment, a region of interest may be identified as any region where indeterminate results are suspected from any images obtained based on the first imaging modality. For example, when NIR spectroscopy is used as the first imaging modality, a region of interest may be defined for a region where the vessel wall is further from the imaging assembly with the imaging probe than allowed by the range of an NIR spectroscopy probe in the presence of blood. Alternatively, such a region may be defined for the case of IVUS imaging when the vessel wall is in contact with the imaging probe. IVUS can be subject to several artifacts in portions of the field of view closest to the catheter. These include a phenomenon known as transducer ring-down, as well as artifacts that arise from ultrasound reflections from the catheter sheath. OCT is substantially less affected by such artifacts and is capable of providing excellent images of portions of the field of view that are closest to the catheter.

In one embodiment, a region of interest may include a stent having a known geometrical shape, structural form and/or imaging signal characteristics. This could include metallic stents, polymeric stents, biodegradable stents, pacemaker wires, guidewires and the like.

Regions of interest may be identified using one of many known image

analysis methods. Regions of interest may be identified by processing images to obtain metrics that can be compared with expected values or ranges. In another example implementation, image analysis is performed in combination with a pattern recognition method for identifying the regions of interest. In one example, 5 the imaging analysis method includes border detection. For example, border detection may be employed for the detection of regions with plaque thickening that are suitable for subsequent imaging by the secondary imaging modality. Border detection may be achieved by a number of different methods. In one non-limiting example, border detection is described by Papadogiorgaki et al. using the 10 contour optimization technique (Ultrasound in Medicine and Biology 2008, Sept 34(9) 1482-98). For example, methods of border detection are taught in US Patent No. 7,359,554, titled "System and Method for Identifying a Vascular Border" and US Patent Publication No. 2005/0249391, titled "Method for Segmentation of IVUS Image Sequences", both of which are incorporated herein 15 by reference in their entirety.

In one embodiment, regions of interest are identified by image processing methods that involve tissue characterization techniques. For example, in applications in which the first imaging modality is IVUS or a variant thereof, regions of interest may be determined by the radio-frequency properties of the 20 backscattered ultrasound signal combined with a pattern recognition algorithm, as taught by Nair in U.S. Patent No. 6,200,268, which is incorporated herein by reference in its entirety. Tissue characterization techniques may alternatively employ analysis of the intensity of grayscale pixels. For example, certain

intensity ranges of pixels in the generated images are more likely to represent soft plaque that may further include lipid-rich regions. Alternatively, texture analysis algorithms, such as wavelet decomposition algorithms or algorithms that assess statistical properties the imaging data may be used. Alternatively, 5 heuristic algorithms that detect known properties of certain tissue components may be utilized. For example, an algorithm may detect acoustic shadowing, which is known to correlate well with the presence of calcifications in IVUS imaging.

It may be desirable to input several imaging data parameters into a pattern 10 recognition algorithm that is able to identify the most likely tissue composition for a particular region. Such a pattern recognition algorithm could be a neural network, fuzzy logic algorithms, a data classification tree, nearest neighbor techniques, and several other pattern recognition techniques. Such a pattern recognition algorithm may be trained using imaging data for which the true 15 underlying composition of the tissue is known, such as by any combination of histology, radiography, spectroscopy, ultrasound, optical imaging and others. Such a pattern recognition algorithm may identify not only the most likely underlying tissue composition for a given region of interest, but also provides an estimate of its likelihood of being correct. Alternatively, the pattern recognition 20 algorithm can simply identify regions for which the underlying composition with the first imaging modality is uncertain, prompting the need for additional analysis with a second imaging modality.

Regions of interest may additionally or alternatively be determined based

a non-imaging modality, such as based on temperature heterogeneity. An example method of detecting thermal heterogeneity is provided in Stefanidis C, et al., "Thermal heterogeneity within human atherosclerotic coronary arteries detected in vivo: a new method of detection by application of a special thermography catheter", Circulation 1999;99;1965-71. A temperature sensor may be incorporated into the distal region of probe 115 to detect a change in the temperature of the wall of the artery, where higher temperatures are thought to more likely correspond to inflammatory regions. In yet another embodiment, regions of interest may be defined based on regions having a minimum concentration of a locally detected biological analyte, such as markers of inflammation, for example detecting C-reactive protein (CRP) by a local biosensor such as an ion-selective field effect transistor (ISFET) having bound thereon a selective detection species such as an antibody or aptamer.

The aforementioned automated systems and methods for identifying regions of interest for further analysis by the second imaging modality may include settings that enable a user to adjust or vary the parameters that influence the identification of regions of interest. For example, such settings may enable the user to select specific pathological features or structures, such as the identification of regions having at least a selected amount of plaque, or a selected minimum vessel wall thickness, or a selected degree of eccentricity in the wall thickness. It is known that plaques are unlikely to reside in regions where there is minimal thickening of the vessel wall and that plaques tend to reside in regions where there is eccentric thickening of the vessel wall.

In another embodiment, the one or more threshold parameters that trigger the identification of a region of interest may be configurable. Such an embodiment is particularly important for applications in which contrast agent, saline solution, or another flush solution is dispensed during a medium displacement operation. By controlling the one or more threshold parameters for which a region of interest is identified, a clinician or operator may be able to control or limit the volume of flush solution delivered during a minimally invasive procedure to ensure that the volume of flush solution employed has a controlled or minimal impact on the patient.

Although the aforementioned embodiments involve automated methods of identifying a region of interest, it is further contemplated that regions of interest may be manually defined by a user or operator by reviewing the results of images obtained via the first translation (e.g. pullback) operation, and selecting regions of interest for a second automated or semi-automated secondary translation operation in which the regions of interest are imaged via the secondary imaging modality while performing medium displacement operations, as further described below.

A region of interest may also be defined or identified according to more than a single imaging modality. For example, the imaging probe may include multiple imaging modalities that are compatible with the presence of an intraluminal medium, and the region of interest may be identified by processing the multiple imaging modalities according to the methods described above.

Referring again to Figure 6, after having obtained one or more regions of interest in step 305, regions of interest to be imaged during a second pullback operation with the second imaging modality are selected in step 310. This step may include automatically selecting all regions of interest identified in step 305,
5 or alternatively, this step may include selecting a subset of the regions of interest identified in step 310. In the latter case, the selection of the subset of regions of interest may be performed by a user operating the system via user interface 225, or may be achieved by pre-selecting types of identified regions that are desired for subsequent analysis.

10 For example, although regions of interest may be identified in step 305 that relate to a wide range of normal anatomical structures, implants, tissue types, and pathological structures or signatures, the system may be configured to only image a detected implant using the second imaging modality. Alternatively, the system may rank the regions of interest identified in step 305 according to
15 any of several criteria, such as, but not limited to, plaque size, predicted likelihood of being a thin-capped fibroatheroma, location in the vasculature and others. Once the regions of interest are ranked, a subset may be selected, such as a group of the regions of interest that ranked highest according to the criteria used.

20 Having selected the regions of interest for imaging via the second imaging modality (either automatically or via user intervention), a second pullback operation is then performed to image the selected regions of interest. This operation may be performed according to a number of embodiments, as further

disclosed below.

Initially, the imaging probe (and/or a functional component thereof) is translated to a region of interest selected in step 315. The translation may be performed manually, with feedback from the position sensing system to
5 determine when the probe has been moved to the appropriate location, and may additionally or alternatively involve the automated translation of the imaging probe to position the imaging assembly in the required location.

Image comparison techniques may assist or guide the automated translation of the imaging probe to the desired position. Cross-correlation
10 techniques can be used to identify images or regions within an imaging dataset that are similar to each other. In its simplest form for a 2D image, this involves multiplying the intensity of each pixel in one image with the intensity of the corresponding pixel in another image, and calculating the sum of these products. A highly similar image will have a high sum of products. By repeatedly shifting,
15 rotating and / or morphing one of the images with respect to the other and repeating the cross-correlation calculation, an assessment for the similarity of the two images can be made that takes into account these transformations.

Cross-correlation techniques can be extended to 3D imaging datasets or alternatively be focused on localized regions within 2D imaging datasets. Cross-
20 correlation techniques can be applied to 2D imaging datasets that are derived from 3D imaging data. For example, rather than applying cross-correlation to cross-sectional images, 2D longitudinal images generated by extracting data in any plane from a series of 2D cross-sectional images that are stacked together to

form a 3D dataset can be used. In the present embodiments, cross-correlation of a pre-selected image or imaging dataset corresponding to a start or stop point identified on a first pullback can be applied to imaging data being acquired during a second pullback to better identify the start or stop points for media

5 displacements operations.

Prior to obtaining images via the second imaging modality, a displacement operation is initiated in step 325 for displacing the displaceable medium within the lumen, to support imaging via the second imaging modality. As described above, any suitable displacement operation may be performed, including, but not
10 limited to, flushing or inflation. The displacement operation may be initiated prior to the completion of the translation step 320 such that the system anticipates the time at which a selected region of interest will be assessable by the second imaging modality, and that the displacement operation has had the desired effect of adequately displacing the intraluminal media by the time the translation step
15 320 results in the imaging probe being positioned properly for the second imaging modality to assess the selected region of interest with minimal or no time delay. While displacing the medium, a pullback operation is performed in step 330 for imaging the region of interest using the second imaging modality.

In one embodiment, when performing step 330, in which a translation
20 operation is performed to obtain images from the second imaging modality, additional images may be obtained from the first modality to accommodate or correct for positional errors or disturbances, such as tissue motion and/or errors in position detecting system. If the imaging modalities are accurately co-

registered, acquiring images concurrently with the first and second modality will provide images at the same location, without introducing errors from tissue motion (i.e. cardiac, respiratory, etc). In one embodiment, the displacement operation, pullback operation, and imaging operations are automated by the
5 imaging system to image the selected region of interest. The displacement operation may be performed continuously during the second pullback operation, or may be performed over discrete time or distance intervals. The automated dispensing operation may be activated or enabled by a user during steps 325 and 330, for example, by continuously activating a switch such as a button or foot
10 pedal. Such a supervisory mode of imaging automation assists in ensuring that all medium displacement operations are performed in the presence of an operator. The operator may interrupt the process, for example, if it is deemed that a volume of flush solution employed has exceeded a pre-selected amount.

In alternative embodiments, one or more of steps 330 and 335 may be
15 manually performed. In one embodiment, both steps 330 and 335 are manually performed, and the positions at which to perform the displacement operation and imaging operations are suggested to a user based on the selected regions identified in step 315. For example, an operator may translate the imaging probe, and the system (for example, via user interface 225) may indicate to the user
20 positions at which displacement and imaging are to be performed. The user may then manually perform a displacement operation using a manually actuated medium displacement apparatus 135 as shown in Figure 1.

In another embodiment, the operator may manually translate the imaging

probe, and the imaging system may perform automated dispensing and imaging when the imaging probe passes the regions of interest selected in step 315 (for example, using the integrated medium displacement apparatus 135 in Figure 2, and related monitor/driver and controller components of the system.

5 In yet another example implementation, the imaging probe may be translated in an automated fashion, and the imaging system may indicate to the operator the locations at which a displacement operation is required for obtaining images via the second imaging modality. In such an embodiment, the system may automate the acquisition of images using the second imaging modality
10 whenever a displacement operation is manually performed by the operator.

 In one embodiment, the displacement operation is monitored, for example, by medium displacement monitor 155 shown in Figure 2. As noted above, the parameters monitored may include a volume of flush solution provided for a given medium displacement operation, a total of flush solution
15 provided for multiple medium displacement operations for a given patient and/or minimally invasive procedure, a time duration during which a given medium displacement operation is carried out, a total time duration over which multiple medium displacement operations are carried out for a given patient and/or minimally invasive procedure, and control signals and/or commands
20 communicated to a device or subsystem for achieving medium displacement.

 In one embodiment, a monitored displacement parameter is employed to provide feedback to the imaging system. The system may be provided with threshold ranges or maximum values for monitored displacement parameters.

Exceeding such threshold values may trigger a visible or audible alarm.

Alternatively, exceeding a threshold may result in automatic suspension or termination of a given displacement operation (and optionally alerting an operator of the event). Monitored displacement parameters may be stored and made
5 available to an operator or clinician following a minimally invasive procedure, for example, to be included in documentation relating to the procedure. Alternatively, monitoring of a displacement operation may be employed to determine a time interval or a distance interval over which to perform steps 325 and 330. For example, after translating the imaging probe to a region of interest in step 320
10 and initiating a displacement operation in step 325, the imaging probe may be further translated while imaging and displacing the intraluminal medium until a monitored displacement threshold is exceeded.

It may be desirable to utilize feedback from the processed images in the above embodiments to control and/or optimize the rate of translation and/or
15 rotation of the imaging probe. The pullback or push-forward speed, and/or the rotational speed of a torque cable may be controlled by the processing unit 205 and/or the controller unit 165. These speeds may be modified, determined and/or optimized separately for each imaging modality. Additionally, the speeds may be modified based on images processed by processing unit 205. For example, when
20 assessing the images obtained by the first imaging modality, if the first imaging modality detects a region where the second imaging modality is to be activated, it may be desirable to increase the speed of pullback and / or the speed of rotation of the torque cable while the second imaging modality (for example, OCT) is

being used. Speeding up image acquisition during operation of an imaging modality that requires displacement of intraluminal media may help reduce the duration of displacement or the amount of displacing media, such as contrast, that would need to be introduced while images are obtained.

5 In one embodiment, it may be desirable to selectively disable one or more of the imaging modalities as the speed of rotation or the speed of translation are adjusted. For example, a first modality may identify a region of interest that initiates a media displacement operation, activates a second imaging modality, changes the speed of rotation and / or changes the speed of pullback. If the first
10 modality is rendered less useful by operation at a different speed of rotation and / or speed of pullback, it may be desirable to temporarily disable the first modality until a controller determines that the second modality is to be deactivated.

 For example, if IVUS is the first imaging modality, the system may operate at a rotational speed in the range of 5 to 100 frames per second during IVUS
15 analysis, in which IVUS identifies a region of interest. However, while imaging with a second imaging modality, such as OCT, the rotational speed may be increased to greater than 50 frames per second and the pullback speed may be increased to greater than 2 mm/s. While the limits of rotational speed for useful IVUS image acquisition are implementation specific and application specific, it is
20 recognized that it may be reasonable to either disable or discard IVUS images during OCT acquisitions that employ rapid rotational speeds. In such a case, the end of the region of interest can be identified by the second imaging modality or any of several previously mentioned parameters that do not rely on the first

imaging modality to identify the endpoint of a region of interest, such as time expired, volume of displacement media used or reaching a known position based on position sensor data from the pullback mechanism.

In yet another embodiment, during steps 325 and 330, image processing
5 of the images obtained using the second imaging modality may be performed in real-time to assess the quality of the images. For example, image quality may be assessed by comparing the intensity, signal attenuation or texture of sections of the image, such as sectors, to pre-set desired ranges or thresholds. The images may be analyzed, for example, by the processing unit 205, to ensure that the
10 border of the anatomic structure is relatively or sufficiently contiguous (for example, as defined by a pre-selected metric), with a well delineated border between the vessel wall and the lumen, as would be expected with adequate flushing.

Alternatively, sections of the image can be analyzed to detect or infer the
15 presence of an intraluminal medium such as blood. Blood will typically have a signature or range of appearances for each modality, whether it be based on signal intensity, signal attenuation or, in the case of NIR imaging, spectral content. The quality of the image can be ascertained, at least in part, by ensuring that the signature of blood is not present in each section of the image
20 from which it is desired to have blood displaced.

The perceived image quality may then be employed to provide feedback to step 325 and regulate the medium displacement operation. For example, if an image is deemed to be characterized by a poor signal-to-noise ratio, the rate of

delivery of flush solution, volume of flush solution, time profile of amount flushed, or the volume of inflation for a displacement balloon, may be varied.

Alternatively, data from a non-invasive imaging modality may be used to assess the adequacy of displacement of intraluminal media. For example, an
5 angiogram can be processed in real time or shortly after the displacement means is activated and the resulting images can be processed to determine if the vessel is fully opacified by contrast media. This determination can be done by assessing the change in pixel intensities of the angiogram or by assessing the sharpness of vessel borders in the angiogram.

10 In one embodiment, the image quality obtained by the second imaging modality is assessed in real time, and feedback provided to regulate a parameter related to the displacement operation in order to minimize aspects of the displacement operation. The image quality may be assessed to minimize the time of a displacement operation, the rate of delivery of a flush solution, and/or
15 the volume of flush solution.

In another embodiment, the second pullback operation in step 330 may be initiated once the field of view is adequately improved with flushing based on real time image analysis, after which the imaging probe continues to translate for the acquisition of images until the end of the region of interest. If, in that time period,
20 the field of view provides inadequate image quality, the pullback controller may stop and/or step-back, and resume translation once the field of view is adequate based on the assessment of image quality.

After having performed step 330 and obtained images of a given region of

interest using the second imaging modality, the steps 320 to 330 may be repeated as indicated at 335 to obtain images of additional regions of interest selected in step 315. Accordingly, the method may be performed by performing a full pullback operation in step 300 to identify and select regions of interest, 5 followed by serial pullback and displacement operations in steps 320 to 330 to acquire images for the selected regions of interest using the second imaging modality.

In an alternative embodiment, the initial pullback operation 300 may be performed as a partial pullback operation, in which the pullback operation spans 10 only a portion of the total anatomical region to be imaged. Image analysis step 305 may be performed in real time to identify regions of interest "on the fly". Such regions of interest may then be displayed to a user for real-time selection and subsequent automation of the second pullback, displacement and imaging operations in steps 320-300, for example, in a push-pull reciprocal fashion. 15 Alternatively, the regions of interest may be automatically selected for subsequent analysis, as described above, and steps 320-330 are automatically performed. After having performed steps 300-330 based on a partial pullback operation, additional partial pullback operations are repeated, as shown at 340, until the minimally invasive procedure is deemed complete.

20 In one embodiment, image processing is employed to assist in identifying the start and stop points of a region of interest during a secondary pullback operation. In general, there may be some inaccuracy in the ability to accurately determine a relative position of the imaging probe for secondary pullback

operations using many of the position-sensors due to slack in the imaging conduit, cardiac motion, flow and potential inadvertent movement of the catheters by the user.

In one embodiment, the positioning system is used as a first estimate of when to start and/or stop a secondary pullback operation, and one or more original images taken near the start/stop points from the first pullback operation are employed to compare against the current images acquired during the second pullback operation until an adequate match is found and the beginning of a region of interest is accurately identified. In addition to pathological regions of interest, such relative positioning may be improved using normal anatomical landmarks, such as bifurcations of the vascular anatomy.

Image comparison for determining the accurate starting position of a region of interest during a secondary imaging operation may be achieved by one of several known image comparison methods. In one embodiment, image cross-correlation is employed. In another embodiment, the size of the vessel lumen is employed. In yet another embodiment, the shape of the vessel border (between the media and adventitia layers) is employed. In yet another embodiment, the shape of the lumen border is employed. In yet another embodiment, the presence, shape or size of one more features detected by the first imaging modality, such as calcifications, bifurcations, implants, plaque, thrombus etc are employed. In one embodiment, a combination of position sensor information, image comparison techniques and / or geometric features of the regions are employed to help identify the start and / or stop points.

In one embodiment, the real-time processing of images is performed to support real-time displacement and imaging by the second imaging modality without requiring a second pullback operation. This real-time embodiment is illustrated in the flow chart provided in Figure 7. In step 400, after having

5 positioned the imaging probe at an initial location, one or more images are obtained using the first imaging modality. The images are processed in step 410 according to methods described in the above embodiments. The real-time image processing may involve processing of individual images on an isolated basis to determine whether or not an image corresponding to the current location of the

10 imaging probe is of interest for secondary imaging, or determining whether or not the current position corresponds to a region of interest based on an aggregated analysis of images in a spatial region preceding the present position. Alternatively, the real-time image processing may involve processing of a

15 sequence of images that would correspond to a 3D dataset to provide greater certainty as to the presence of a region of potential interest for imaging with the second modality.

In step 420, a decision is made as to whether or not the current position corresponds to a region of interest. If the results from the image processing step suggest that the current position corresponds to a region of interest, then step

20 430 is performed, and a media displacement operation is directed. In another example, the decision may also be based on information from a fiducial marker (such as, but not limited to, a marker band detectable via angiography). As noted above, this may be performed either in an automated fashion, or in a semi-

automated fashion in which the system prompts the operator to perform or activate the medium displacement operation. After the medium displacement operation is initiated, the secondary imaging modality is employed in step 440 to obtain images at the current position. The imaging probe is then translated to a
5 new position in step 450, and the process is repeated according to step 460.

If, however, in step 420, the current position is not deemed to correspond to a region of interest, steps 430 and 440 are bypassed, and step 450 is executed by translating the imaging probe to a new position. The process is then repeated according to step 460. The aforementioned real-time method is either
10 performed in a stop-start manner, as disclosed, where the imaging probe is at rest when medium displacement and secondary imaging steps are performed, or with continuous pull-back.

Although the preceding embodiment was illustrated as a series of discrete steps, it is to be understood that other variations of the embodiment may
15 implemented. For example, in a variation of the above embodiment, the imaging probe may be translated using a motor or other drive system that is not immediately stopped while the image processing step is performed, such that by the time that the determination is made that a region of interest has been identified, the probe (or functional component of the probe) may have been
20 translated slightly beyond the position at which the images were obtained. In one example, this may be remedied by translating the functional component of the image probe in backwards direction by a suitable amount prior to initiating the displacement operation. Alternatively, if the overshoot is sufficiently small, the

displacement operation may be directly initiated without a corrective backward translation step. In other embodiments, the imaging probe may be translated continuously while performing one or more of steps 400 to 430 of Figure 7.

In one embodiment, where continuous pullback is employed, the
5 controller for the secondary imaging modality can identify when suboptimal imaging data has been acquired and declare (for example, via a notification) that a fault has occurred. The fault may be responded to by reversing the direction of translation of the imaging probe until the region that corresponded to the fault has been traversed, and re-initiating steps 430 to 450 while resuming the normal
10 direction of translation.

Alternatively, having initiated a medium displacement operation in step 430 based on identifying a particular position as a region of interest, the medium displacement operation may continue to be activated while repeating the process, until a new position is reached that is no longer identified as a region of
15 interest. When such a new position is reached, the medium displacement operation is terminated after performing step 420, and before performing step 450. Such an embodiment enables the automation of a serial measurement cycle in which secondary imaging is performed at multiple successive positions without having to terminate and re-initiate a medium displacement operation.

20 In a variation of the above approach, it may be preferable to translate the imaging probe in a reverse direction over a small distance prior to performing a medium displacement operation. Alternatively, a small reverse step (for example, on the order of < 20 mm, and more preferably < 5 mm) may be taken after

automatically identifying the start of region of interest so that the leading edge of the region of interest is included with the imaging data collected after blood is displaced. For example, a pullback operation may be executed until a region of interest is identified, upon which a reverse (e.g. push-forward) step of

5 approximately 2 mm is taken, followed by the initiation of a medium displacement operation. The pullback operation is then resumed for imaging with the secondary (and optionally the primary) imaging modalities, until end of a region of interest is identified, at which point the displacement operation is ceased. This method would then be repeated to identify and image the next region of interest.

10 An imaging probe for use with the aforementioned real-time embodiments may include a more proximal sensor for detection of regions of interest based on the first imaging modality (compatible with the intraluminal medium) and a more distal sensor based on a second imaging modality whose performance is improved via detection of regions of interest by the more proximal sensor and the

15 displacement of the intraluminal medium.

More generally, an imaging probe for use with the aforementioned real-time embodiments may include a sensor positioned or oriented on the probe for detection of regions of interest based on the first imaging modality (compatible with the intraluminal medium) such that it will assess a potential region of interest

20 before a second sensor based on a second imaging modality is positioned or oriented to assess the corresponding regions of interest, whose performance is improved via detection of regions of interest by the first sensor and the displacement of the intraluminal medium.

While some of the aforementioned embodiments employ a second pullback operation to obtain images using the second imaging modality in combination with a displacement operation, it is to be understood that the second imaging step may be executed by directing the probe in a forward direction as
5 opposed to a reverse direction. In particular, such a push-forward operation may be favorable as the imaging assembly will be moving in the same direction as a bolus of displacing fluid, allowing more of a vessel to be imaged with a given amount of displacement fluid (because the imaging core follows the displacing fluid rather than travelling in an opposite direction of it). Furthermore, it is to be
10 understood that a pullback operation may be achieved by pullback of the total imaging probe, or pullback of a core component of an imaging probe.

In another embodiment, the images obtained from the first and second imaging modalities may be processed to provide a score or index indicating how successfully a minimally invasive procedure involving combined imaging
15 modalities was executed. For example, the score or index may be determined by calculating the percentage or absolute value of the pullback length where adequate displacement of intraluminal media took place. Such a score or index could be used to determine which datasets provide adequate quality for the purposes of a particular study or trial. Alternatively, the score or index could
20 provide an indication as to whether or not a minimally invasive procedure should be repeated, possibly with varied parameters such as sensitivity and/or speed.

It is to be understood that while the aforementioned embodiments have recited methods and systems pertaining to multimodal imaging probes

comprising two imaging modalities, the imaging probe may include additional imaging modalities. In one embodiment, multiple imaging modalities compatible with the presence of an intraluminal medium may be utilized for the identification of regions of interest. Additionally, multiple imaging modalities that benefit from
5 the displacement of the displaceable intraluminal medium may be employed for the imaging of identified regions of interest.

In the preceding embodiments, emphasis has been placed on operations where the region or field of view assessed by one or more sensors is determined substantially by translation operations, such as pullback or push-forward
10 operations. The methods and devices described apply equally to other imaging systems where the region imaged, assessed or treated by the first and second modalities is determined by operations other than a translation. For example, the imaging probe 31 described in Figures 4a to 4d is capable of imaging a broad region with both optical and ultrasound imaging and the imaging angle is
15 determined in part by the tilt angle of deflectable component 70. For such a probe, the embodiments for controlling media displacement described above and in Figures 6 and 7 can have the translation operation substituted by a deflection operation. For example, when the imaging angle is large, ultrasound imaging may determine that there is no region of interest in the present field of view that
20 requires further analysis with a second imaging modality. A region of interest may be identified at a more forward-looking imaging angle that would benefit from media displacement operations.

Similarly, electronic steering methods, such as those used with 2D or 3D

ultrasound probes, such as linear array ultrasound transducers or phased array transducers, do not rely solely on translation or deflection to determine the region imaged. Such arrays may be incorporated into minimally invasive imaging probes and may be used as either the first or second or both of the imaging modalities for the present disclosure, and may benefit from the use of media displacement operations.

In yet another embodiment, an external imaging apparatus may form a component of the system. Examples of external imaging modalities include angiography, CT angiography, magnetic resonance imaging and externally applied ultrasound. In one example embodiment, shown in Figure 8, system 500 may include a fluoroscopy imaging apparatus 510 that is optionally connected to computing system 220 (for example, connected to processing unit 205). While performing a translation operation and collecting images via the first or second imaging modalities, an image acquisition trigger signal may be provided to the external imaging apparatus that triggers the external system to collect one or more frames of images during one or more translation operations of the imaging probe. In one example, the signal may be provided at intervals of interest, where such intervals may be, for example, uniformly separated in time or along the range of a translation operation. Alternatively, the intervals may occur at time intervals related to the initiation or termination of medium displacement operation or at points when the imaging probe is imaging a determined region of interest.

In another embodiment, the external imaging apparatus may be employed to identify one or more a regions of interest. The regions of interest may then be

employed for subsequent imaging using an imaging modality of the imaging probe, wherein the imaging modality of the imaging probe benefits from the displacement of an intraluminal medium. In one example implementation, the first imaging modality is a fluoroscopy imaging device and the system is
5 configured for the delivery of a contrast medium (for example, during an cardiac angiography procedure). During an initial operation, the fluoroscopy imaging device is employed to image a region including a lumen into which the imaging probe may be advanced.

In the case of fluoroscopy imaging, the imaging probe, or an additional
10 flush catheter, may be initially employed to deliver contrast media within the lumen while acquiring one or more initial fluoroscopy images. The acquired initial fluoroscopy image or images may be employed to identify one or more regions of interest to be imaged by the imaging modality of the imaging probe. The one or more regions of interest may be manually identified by observation of the one or
15 more initial images. For example, one or more of the regions of interest may correspond to locations of luminal narrowing.

In one example implementation, the external diagnostic apparatus may be employed to guide the imaging catheter to the region of interest identified on the one or more initial images. For example, the imaging probe may include a fiducial
20 marker, such as a radiopaque marker (e.g. a radiopaque marker band), which enables the identification of the location of the imaging assembly using the external imaging apparatus. Accordingly, the imaging probe may be positioned such that it can be translated through a path that is known to contain one or more

regions of interest using the external imaging apparatus, and the location of the imaging probe during a translation operation operation may be tracked using the external diagnostic apparatus and compared to the initial images to identify whether or not medium displacement is required at the current location.

5 In yet another example implementation involving an external diagnostic imaging device, the imaging probe may include first and second imaging modalities, where the first imaging modality is compatible with the presence of an intraluminal medium, and where the second imaging modality benefits from the displacement of the intraluminal medium. The regions of interest for acquiring
10 images with the second imaging modality (while performing a medium displacement operation) may be identified by both the external diagnostic device (as described above) and the first imaging modality (during an initial translation and imaging operation involving the first imaging modality).

 Generally speaking, it is to be understood that the intraluminal medium
15 may be any medium that potentially impairs the performance of an imaging modality. Furthermore, while the above embodiments relate to intraluminal probe-based imaging methods involving the displacement of an intraluminal fluid, it is to be understood that the aforementioned methods may be applied to any medical imaging application in which a first imaging modality may be employed to
20 direct the displacement of a displaceable medium for improving or supporting imaging based on a second imaging modality.

 Suitable applications for the aforementioned embodiment of the disclosure involve imaging of the gastrointestinal system, the cardiovascular system

(including coronary, peripheral and neurological vasculature), respiratory system, eyes (including the retina), auditory system, genitourinary systems, and many others.

Finally, it is to be understood that while the preceding embodiments have
5 disclosed methods in which the process of obtaining images from a second
imaging modality is aided by the medium displacement operation, it is to be
understood that the use of a second imaging modality is but one example of a
second minimally invasive procedure that is aided or improved by the medium
displacement operation. Accordingly, on other embodiments, the aforementioned
10 methods may be adapted to enable a minimally invasive procedure such as
automated or semi-automated delivery of a therapy to a region of interest, where
the therapy requires or benefits from a medium displacement operation. For
example, in the aforementioned methods, the secondary imaging step may be
combined with, or alternatively replaced by, a treatment operation that is
15 performed over a region of interest while performing a medium displacement
operation. Non-limiting examples of such therapeutic minimally invasive
procedures include photodynamic therapy, laser ablation, and the application of
electrical energy, such as radiofrequency energy, where the delivery of the
treatment is guided by the regions of interest identified during a pullback
20 operation involving a primary imaging modality that is compatible with the
presence of the intraluminal medium.

The specific embodiments described above have been shown by way of
example, and it should be understood that these embodiments may be

susceptible to various modifications and alternative forms. It should be further understood that the claims are not intended to be limited to the particular forms disclosed, but rather to cover all modifications, equivalents, and alternatives falling within the spirit and scope of this disclosure.

THEREFORE WHAT IS CLAIMED IS:

1. A method of directing a medium displacement operation for performing a minimally invasive procedure within a lumen or cavity, the method comprising the steps of:

recording a first set of images obtained from a first imaging modality when a first translation operation of a functional component of an imaging probe is performed;

spatially correlating the first set of images with an associated position of the functional component of the imaging probe, wherein the first imaging modality is compatible with a presence of a displaceable medium;

processing the first set of images and identifying a region of interest; and

directing a medium displacement operation while a second translation operation of the functional component of the imaging probe is performed over the region of interest;

wherein the minimally invasive procedure is performed within the region of interest during the medium displacement operation.

2. The method according to claim 1 wherein the minimally invasive procedure is improved by the medium displacement operation.

3. The method according to claim 1 or 2 wherein the imaging probe comprises an additional imaging modality compatible with a presence of the displaceable medium, the method further comprising the steps of:

recording an additional set of images obtained from the additional imaging modality when the first translation operation is performed, and wherein the additional set of images are spatially correlated with the position of the functional component of the imaging probe; and

processing the additional set of images and further identifying the region of interest.

4. The method according to claim 1 wherein the minimally invasive procedure is a therapeutic procedure.

5. The method according to any one of claims 1 to 4 further comprising the steps of:

processing the first set of images and identifying an additional region of interest;

directing an additional medium displacement operation while an additional translation operation is performed over the additional region of interest; and

wherein an additional minimally invasive operation is performed within the additional region of interest during the additional medium displacement operation.

6. The method according to any one of claims 1 to 5 wherein one or more of the first translation operation and the second translation operation are manually performed.

7. The method according to any one of claims 1 to 5 further comprising the steps of automating one or more of the first translation operation and the second translation operation.

8. The method according to any one of claims 1 to 7 wherein the step of directing the medium displacement operation comprises indicating to an operator that the medium displacement operation is to be performed when the imaging probe is translated within the region of interest.

9. The method according to any one of claims 1 to 8 wherein the step of directing the medium displacement operation comprises automating the medium displacement operation.

10. The method according to claim 9 wherein the medium displacement operation is automated after receiving an input from a user authorizing the medium displacement operation.

11. The method according to claim 9 or 10 wherein the step of automating the medium displacement operation comprises controlling a medium displacement apparatus to perform the medium displacement operation.

12. The method according to claim 11 wherein the medium displacement

apparatus includes a fluid delivery apparatus.

13. The method according to claim 12 wherein the fluid delivery apparatus further comprises a component selected from the group consisting of an auto-injector, pressure infuser bag, peristaltic pump, syringe pump, piston pump, valved system, gravity pressurized system, and a means for the external application of pressure.

14. The method according to any one of claims 1 to 13 further comprising the step of monitoring a parameter related to the medium displacement operation.

15. The method according to claim 14 further comprising the steps of alerting an operator or terminating the medium displacement operation when the parameter does not lie within a pre-determined range of values.

16. The method according to any one of claims 1 to 15 wherein the step of processing the first set of images comprises processing three-dimensional image data.

17. The method according to any one of claims 1 to 16 wherein the step of identifying the region of interest comprises comparing the first set of images to known or expected properties.

18. The method according to claim 17 wherein the known or expected properties are spatial profiles and/or tissue types of one or more of normal anatomical features, pathological anatomical features, and medical implants.

19. The method according to claim 17 wherein the step of comparing the first set of images to known or expected properties comprises computing a comparison metric and comparing the comparison metric with a threshold value or range of values.

20. The method according to claim 19 wherein the threshold value is configurable by an operator.

21. The method according to any one of claims 1 to 20 wherein more than one region of interest is identified, the method further comprising the steps of:
 ranking the regions of interest according to predetermined criteria; and
 selecting a subset of the regions of interest according to the ranking;
 wherein the steps of directing the medium displacement operation while the second translation operation is performed over the region of interest are performed for each region of interest within the subset.

22. The method according to any one of claims 1 to 21 wherein the step of processing the first set of images includes executing a pattern recognition algorithm.

23. The method according to any one of claims 1 to 21 wherein the step of processing the first set of images includes one of determining a spatial profile of a detected border, a tissue type, and a temperature profile.

24. The method according to claim 23 wherein the first imaging modality is intravascular ultrasound, and wherein the step of determining a tissue type comprises analysis of radio-frequency properties of a backscattered ultrasound signal.

25. The method according to claim 23 wherein the step of determining a tissue type comprises performing a method selected from the group consisting of grayscale pixel analysis, radiofrequency analysis, texture analysis, and heuristic analysis.

26. The method according to any one of claims 1 to 25 wherein the region of interest includes a substance or feature selected from the group consisting of plaque, thrombus, branch points, lesions, calcifications, stents, brachytherapy implants, stenoses, areas of vessel wall thickening, lipid cores, necrotic regions, fibrous caps, dissections, microbubbles, targeted microbubbles, vascular lesions, and a combination thereof.

27. The method according to any one of claims 1 to 26 wherein the region of

interest is associated with indeterminate results obtained by processing the first set of images.

28. The method according to any one of claims 1 to 25 wherein the step of identifying the region of interest includes the steps of:

providing the first set of images to an operator; and

receiving input from the operator, wherein the input identifies the region of interest.

29. The method according to claim 28 wherein the input comprises a subset of images, the subset corresponding to the region of interest, and wherein the step of identifying the region of interest further comprises identifying a relative position range corresponding to the subset of the first set of images.

30. The method according to claim 28 wherein the step of providing the first set of images to the operator further comprises providing a relative position corresponding to each image within the first set of images, wherein the input comprises a relative position range corresponding to a subset of the first set of images.

31. The method according to any one of claims 1 to 30 wherein the first imaging modality is selected from the group consisting of grayscale IVUS, radio-frequency IVUS, Virtual Histology (TM), integrated backscatter, iMap(TM)

elastography, NIR spectroscopy, sono-luminescent imaging, microbubble enhanced IVUS, targeted microbubble enhanced IVUS, photo-acoustic imaging, fluorescence spectroscopy, biosensors, and ion-selective field effect transistors.

32. The method according to any one of claims 1 to 31 wherein the minimally invasive procedure includes the steps of obtaining a second set of images obtained from a second imaging modality while the medium displacement operation is performed, and spatially correlating the second set of images with an associated position of the functional component of the imaging probe.

33. The method according to claim 32 further comprising processing the first set of images and the second set of images to spatially correlate the first set of images with the second set of images.

34. The method according to claim 33 further comprising the step of identifying at least one of a start and a stop position of the region of interest within the second set of images.

35. The method according to claim 33 or 34 wherein the step of processing the first and second set of images comprises identifying, in the first set of images and the second set of images, a feature selected from the group consisting of pathological landmarks, anatomical landmarks, sizes of anatomical features, diameter of a lumen, bifurcations of a vascular anatomy, a shape of a vessel

border, and a combination thereof.

36. The method according to any one of claims 33 to 35 wherein the step of processing the first and second set of images comprises cross-correlating at least a portion of the first set of images and the second set of images.

37. The method according to any one of claims 33 to 36 wherein the step of processing the first and second set of images comprises processing three-dimensional image data.

38. The method according to any one of claims 32 to 37 wherein the second imaging modality is selected from the group consisting of OCT, angiography, angioscopy, NIR spectroscopy, Raman spectroscopy, IVUS, radio-frequency IVUS, elastography, sono-luminescent imaging, microbubble enhanced IVUS, targeted microbubble enhanced IVUS, fluorescence spectroscopy, and photo-acoustic imaging.

39. The method according to any one of claims 32 to 38 further comprising the step of processing the second set of images in real-time to determine a measure of a quality of the second set of images, and controlling the medium displacement operation to improve the quality.

40. The method according to any one of claims 32 to 39 further comprising the

steps of:

identifying when suboptimal imaging data has been acquired using the second imaging modality and determining that a fault has occurred.

41. The method according to claim 40 further comprising the steps of:

reversing a direction of translation of the functional component of the imaging probe until a region that corresponded to the fault has been traversed, and;

directing an additional medium displacement operation while an additional translation operation is performed over the region corresponding to the fault; and

recording additional images obtained from the second imaging modality while the additional medium displacement operation is performed, and wherein the additional images are spatially correlated with a relative position of the imaging probe.

42. The method according to any one of claims 1 to 41 wherein the medium displacement operation comprises the step of providing a flushing solution including a contrast medium, wherein the method further comprises the step of determining an adequacy of the medium displacement operation using an external imaging modality.

43. The method according to claim 42 wherein the external imaging modality comprises angiography.

44. The method according to any one of claims 32 to 41 wherein the first imaging modality and the second imaging modality employ the same form of imaging energy.

45. The method according to any one of claims 1 to 44 wherein at least one of the first translation operation and the second translation operation include a pullback operation.

46. The method according to any one of claims 1 to 45 wherein at least one of the first translation operation and the second translation operation includes a push-forward operation.

47. The method according to any one of claims 1 to 46 wherein the speed of one or more of the first translation operation and the second translation operation are configured for an associated imaging modality.

48. The method according to claim 47, wherein the speed of the second translation operation is faster than the speed of the first translation operation.

49. The method according to any one of claims 1 to 48 wherein the imaging probe is positioned within a lumen.

50. The method according to claim 49 wherein the lumen is an interior of a blood vessel.

51. The method according to any one of claims 1 to 50 further comprising the step of disabling the first imaging modality while performing the minimally invasive procedure.

52. The method according to any one of claims 1 to 50 further comprising the step of providing an image acquisition triggering signal to an external imaging apparatus during one or more of the first translation operation and the second translation operation for correlating acquisition of images obtained by the external imaging apparatus with an associated position of the functional component of the imaging probe.

53. The method according to claim 52 wherein the image acquisition triggering signal is provided according to a pre-selected time interval.

54. The method according to claim 52 wherein the image acquisition triggering signal is provided at time intervals related one or more of the initiation of a medium displacement operation, the termination of a medium displacement operation, and time points when the imaging probe is imaging a region of interest.

55. The method according to any one of claims 1 to 54 wherein the functional component of the imaging probe is an imaging assembly.

56. A method of directing a medium displacement operation for performing a minimally invasive imaging procedure within a lumen or cavity, the method comprising the steps of:

a) obtaining one or more images from a first imaging modality of an imaging probe, wherein the first imaging modality is compatible with a presence of a displaceable medium;

b) processing the one or more images to identify a region of interest; and

c) if a region of interest is identified, directing a medium displacement operation and performing a minimally invasive procedure while the medium displacement operation is performed.

57. The method according to claim 56 wherein the minimally invasive procedure is improved by the medium displacement operation.

58. The method according to claim 56 or 57 further comprising the step of spatially correlating the one or more images with a relative position of the imaging probe.

59. The method according to any one of claims 56 to 58 wherein the step of recording the one or more images includes obtaining forward-looking images in a

forward-looking direction, and wherein the step of processing the one or more images further includes processing the forward-looking images to determine if a position in a forward-looking direction of the imaging probe is a region of interest.

60. The method according to claim 59 further comprising the step of translating a functional component of the imaging probe to the position in the forward-looking direction prior to the step of directing the medium displacement operation and performing the minimally invasive procedure.

61. The method according to claim 59 wherein the minimally invasive procedure includes obtaining one or more images from an additional forward looking imaging modality in a forward looking direction.

62. The method according to claim 61 wherein the step of obtaining one or more images in a forward looking direction according to one or both of the first imaging modality and the additional forward looking imaging modality is performed by controlling an orientation of a movable member within an imaging assembly of the imaging probe for deflecting imaging energy in the forward looking direction.

63. The method according to any one of claims 56 to 62 further comprising the steps of:

d) translating a functional component of the imaging probe to a new

position, and

e) repeating steps a) through c).

64. The method according to claim 63 wherein the new position is adjacent to the current position.

65. The method according to claim 63 or 64 wherein when a given position is determined to be a region of interest, the medium displacement operation is continued until a subsequent position is no longer determined to be a region of interest.

66. The method according to any one of claims 63 to 65 wherein the step of translating the functional component of the imaging probe includes moving the functional component of the imaging probe in a forward direction.

67. The method according to any one of claims 56 to 62 wherein a functional component of the imaging probe is translated while performing any one or more of steps a), b) and c).

68. The method according to claim 67 further comprising repeating steps a) through c) one or more times.

69. The method according to any one of claims 56 to 68 wherein the imaging

probe includes an additional imaging modality compatible with a presence of the displaceable medium, the method further comprising the steps of:

recording an additional set of images obtained from the additional imaging modality; and

further processing the additional set of images to identify a region of interest.

70. The method according to any one of claims 56 to 69 wherein the minimally invasive procedure is a therapeutic procedure.

71. The method according to any one of claims 56 to 70 further comprising the step of terminating the medium displacement operation prior to translating a functional component of the imaging probe to a new position.

72. The method according to any one of claims 56 to 71 wherein the step of directing the medium displacement operation includes automating the medium displacement operation.

73. The method according to claim 72 wherein the medium displacement operation is automated after receiving an input from a user authorizing the medium displacement operation.

74. The method according to claim 72 wherein the step of automating the

medium displacement operation includes controlling a medium displacement apparatus to perform the medium displacement operation.

75. The method according to claim 74 wherein the medium displacement apparatus includes a fluid delivery apparatus.

76. The method according to claim 75 wherein the fluid delivery apparatus further comprises a component selected from the group consisting of an auto-injector, pressure infuser bag, peristaltic pump, syringe pump, piston pump, valved system, gravity pressurized system, and a means for the external application of pressure.

77. The method according to any one of claims 56 to 76 further comprising the step of monitoring a parameter related to the medium displacement operation.

78. The method according to claim 77 further comprising one of alerting an operator and terminating the medium displacement operation when the parameter does not lie within a pre-determined range of values.

79. The method according to any one of claims 56 to 78 wherein the step of processing one or more images obtained from the first imaging modality further comprises processing images obtained in a spatial region preceding a current position of the imaging probe.

80. The method according to any one of claims 56 to 79 wherein the step of processing the one or more images obtained from the first imaging modality includes processing three-dimensional image data.

81. The method according to any one of claims 56 to 80 wherein the step of identifying the region of interest includes comparing the one or more images obtained from the first imaging modality to known or expected properties.

82. The method according to claim 81 wherein the step of comparing the one or more images obtained from the first imaging modality to known or expected properties comprises computing a comparison metric and comparing the comparison metric with a threshold value.

83. The method according to claim 82 wherein the threshold value is configurable by an operator.

84. The method according to claim 81 wherein the known or expected properties are spatial profiles and/or tissue types of one or more of normal anatomical features, pathological anatomical features, and medical implants.

85. The method according to any one of claims 56 to 84 wherein the step of processing the one or more images obtained from the first imaging modality

includes one of determining a spatial profile of a detected border, a tissue type, and a temperature profile.

86. The method according to claim 85 wherein the step of determining a tissue type comprises performing a method selected from the group consisting of grayscale pixel analysis, radiofrequency analysis, texture analysis, and heuristic analysis.

87. The method according to claim 85 wherein the first imaging modality is IVUS, and wherein the step of determining a tissue type comprises analysis of radio-frequency properties of a backscattered ultrasound signal.

88. The method according to any one of claims 56 to 87 wherein the step of processing the one or more images obtained from the first imaging modality includes executing a pattern recognition algorithm.

89. The method according to any one of claims 56 to 88 wherein the region of interest includes a substance or feature selected from the group consisting of plaque, thrombus, branch points, lesions, calcifications, stents, brachytherapy implants, stenoses, areas of vessel wall thickening, lipid cores, necrotic regions, fibrous caps, dissections, microbubbles, targeted microbubbles, vascular lesions, and a combination thereof.

90. The method according to any one of claims 56 to 89 wherein the region interest is associated with indeterminate results obtained by processing of the one or more images obtained from the first imaging modality.

91. The method according to any one of claims 56 to 90 wherein the first imaging modality is selected from the group consisting of grayscale IVUS, radio-frequency IVUS, Virtual Histology (TM), integrated backscatter, iMap(TM), elastography, NIR spectroscopy, sono-luminescent imaging, microbubble enhanced IVUS, targeted microbubble enhanced IVUS, photo-acoustic imaging, fluorescence spectroscopy, biosensors, and ion-selective field effect transistors.

92. The method according to any one of claims 56 to 71 wherein the minimally invasive procedure includes obtaining one or more images from a second imaging modality.

93. The method according to claim 92 further comprising the step of processing the one or more images obtained from the first imaging modality and one or more images obtained from the second imaging modality to spatially correlate one or more images obtained from the first imaging modality with the one or more images obtained from the second imaging modality.

94. The method according to claim 93 wherein the step of processing the one or more images obtained from the first imaging modality and the one or more

images obtained from the second imaging modality includes identifying, in the one or more images obtained from the first imaging modality and the one or more images obtained from the second imaging modality, a feature selected from the group consisting of pathological landmarks, anatomical landmarks, sizes of anatomical features, diameter of a lumen, bifurcations of a vascular anatomy, a shape of a vessel border, and a combination thereof.

95. The method according to claim 93 wherein the step of processing the one or more images obtained from the first imaging modality and the one or more images obtained from the first imaging modality includes cross-correlating at least a portion of the one or more images obtained from the first imaging modality and the one or more images obtained from the second imaging modality.

96. The method according to any one of claims 93 to 95 wherein the step of processing the one or more images obtained from the first imaging modality and the one or more images obtained from the second imaging modality includes processing three-dimensional image data.

97. The method according to any one of claims 92 to 96 wherein the second imaging modality is selected from the group consisting of OCT, angiography, angioscopy, NIR spectroscopy, Raman spectroscopy, IVUS, radio-frequency IVUS, elastography, sono-luminescent imaging, microbubble enhanced IVUS, targeted microbubble enhanced IVUS, fluorescence spectroscopy, and photo-

acoustic imaging.

98. The method according to any one of claims 92 to 97 further comprising the step of processing the one or more images obtained from the second imaging modality in real-time to determine a measure of a quality of the one or more images obtained from the second imaging modality.

99. The method according to claim 98 further comprising controlling the medium displacement operation to improve the quality.

100. The method according to claim 92 wherein the first imaging modality and the second imaging modality employ the same form of imaging energy.

101. The method according to any one of claims 56 to 100 imaging probe is positioned within a lumen.

102. The method according to claim 101 wherein the lumen is an interior of a blood vessel.

103. The method according to claim 98 further comprising the steps of:

identifying when suboptimal imaging data has been acquired using the second imaging modality and providing a notification that a fault has occurred;
and

obtaining an additional set of images using the second imaging modality.

104. The method according to any one of claims 56 to 103 further comprising the step of providing an image acquisition triggering signal to an external imaging apparatus during one or more of the first translation operation and the second translation operation for correlating acquisition of images obtained by the external imaging apparatus with the relative position of the imaging probe.

105. The method according to claim 104 wherein the image acquisition triggering signal is provided according to a pre-selected time interval.

106. The method according to claim 104 wherein the image acquisition triggering signal is provided at time intervals related one or more of the initiation of a medium displacement operation, the termination of a medium displacement operation, and time points when the imaging probe is imaging a region of interest.

107. A method of directing a medium displacement operation for performing a minimally invasive procedure within a lumen or cavity with a probe, the method comprising the steps of:

obtaining, with an external imaging apparatus, one or more images of a region within which the minimally invasive procedure is to be performed;

identifying a region of interest within the one or more images;

translating a functional component of the probe to the region of interest while obtaining one or more additional images with the external imaging apparatus, wherein a position of the functional component is identifiable in the one or more additional images; and

directing a medium displacement operation while performing a translation operation associated with the functional component of the probe within the region of interest.

108. The method according to claim 107 further comprising the step performing the minimally invasive procedure within the region of interest during the medium displacement operation.

109. The method according to claim 107 or 108 wherein the functional component of the probe includes a fiducial marker identifiable by the external imaging apparatus.

110. The method according to claim 109 wherein an imaging modality of the external imaging apparatus is fluoroscopy, and wherein the fiducial marker is a radiopaque marker.

111. The method according to any one of claims 107 to 110 further comprising the step of directing an additional medium displacement operation during the step of obtaining the one or more images with the external imaging apparatus.

112. The method according to any one of claims 107 to 111 imaging probe is positioned within a lumen.

113. The method according to claim 112 wherein the lumen is an interior of a blood vessel.

114. A method of directing a medium displacement operation for performing a minimally invasive procedure within a lumen or cavity, the method comprising the steps of:

recording a set of measurements obtained from a non-imaging modality when a first translation operation of a functional component of a probe is performed;

spatially correlating the set of measurements with an associated position of the functional component of the probe, wherein the non-imaging modality is compatible with a presence of a displaceable medium;

processing the set of measurements and identifying a region of interest;
and

directing a medium displacement operation while a second translation operation of the functional component of the probe is performed over the region of interest;

wherein the minimally invasive procedure is performed within the region of interest during the medium displacement operation.

115. A method of directing a medium displacement operation for performing a minimally invasive imaging procedure within a lumen or cavity, the method comprising the steps of:

a) obtaining one or more measurements from a non-imaging modality of a probe, wherein the non-imaging modality is compatible with a presence of a displaceable medium;

b) processing the one or more measurements to identify a region of interest; and

c) if a region of interest is identified, directing a medium displacement operation and performing a minimally invasive procedure while the medium displacement operation is performed.

116. The method according to claim 115 further wherein the non-imaging modality is selected from the group consisting of thermography and sensing a biological analyte.

117. The method according to claim 115 further comprising the steps of:

d) translating a functional component of the probe to a new position, and

e) repeating steps a) through c).

118. The method according to claim 117 wherein the non-imaging modality is selected from the group consisting of thermography and sensing a biological

analyte.

119. The method according to claim 117 wherein the new position is adjacent to the current position.

120. The method according to any one of claims 117 to 119 wherein when a given position is determined to be a region of interest, the medium displacement operation is continued until a subsequent position is no longer determined to be a region of interest.

121. The method according to any one of claims 117 to 120 wherein the step of translating the functional component of the probe includes moving the functional component of the probe in a forward direction.

122. The method according to any one of claims 115 to 121 wherein a functional component of the probe is translated while performing any one or more of steps a), b) and c).

123. The method according to claim 122 further comprising repeating steps a) through c) one or more times.

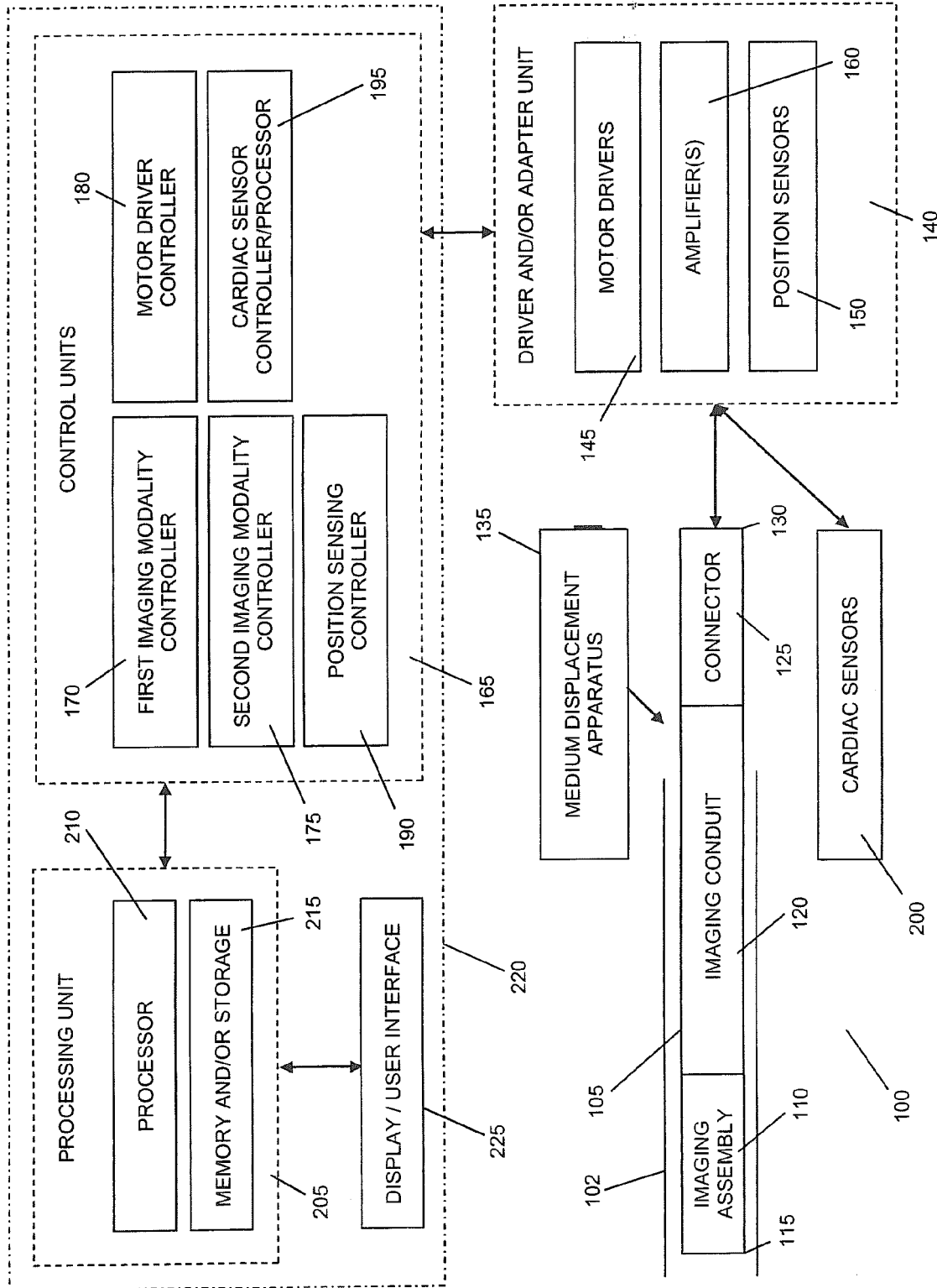

Figure 1

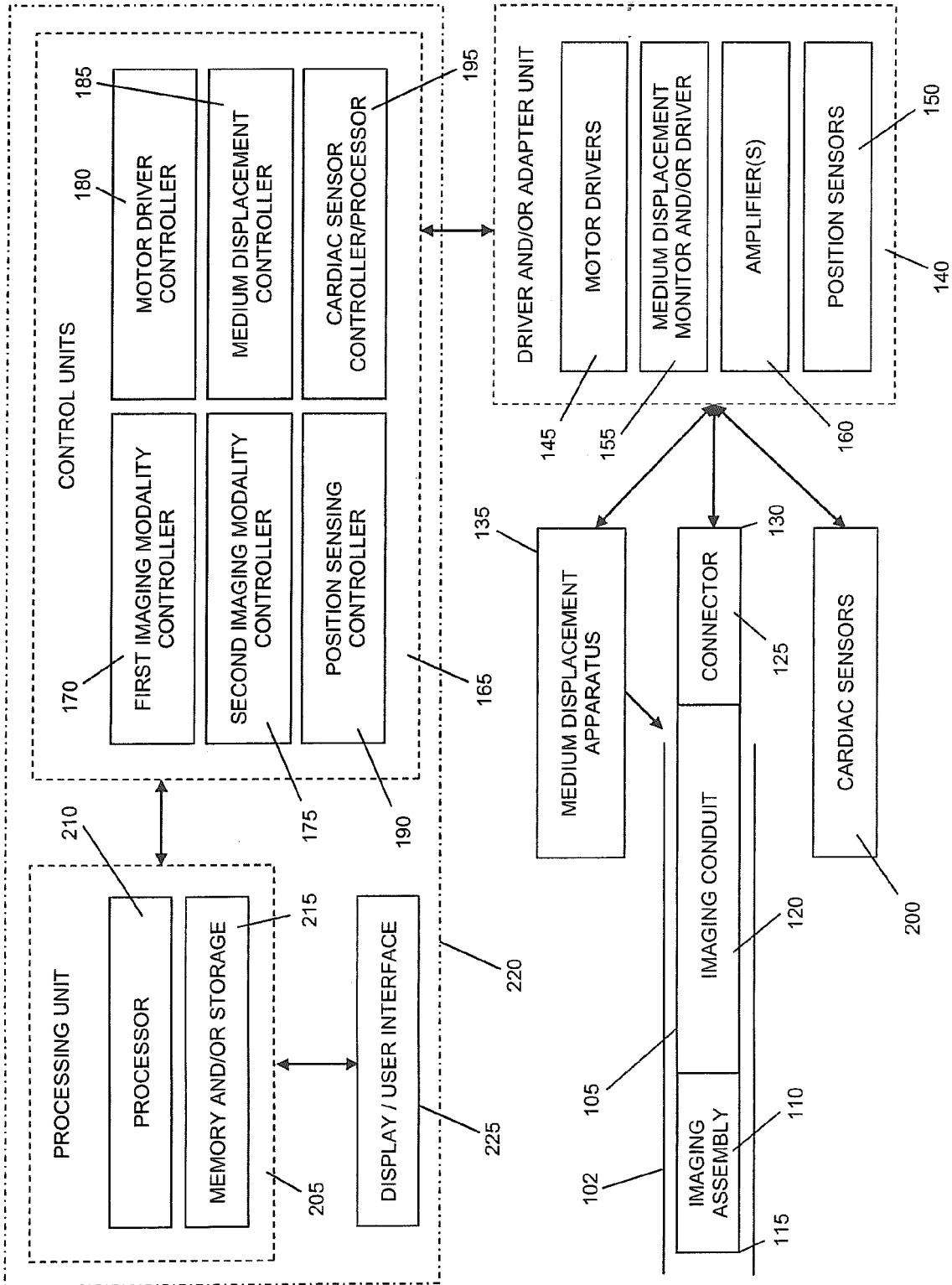

Figure 2

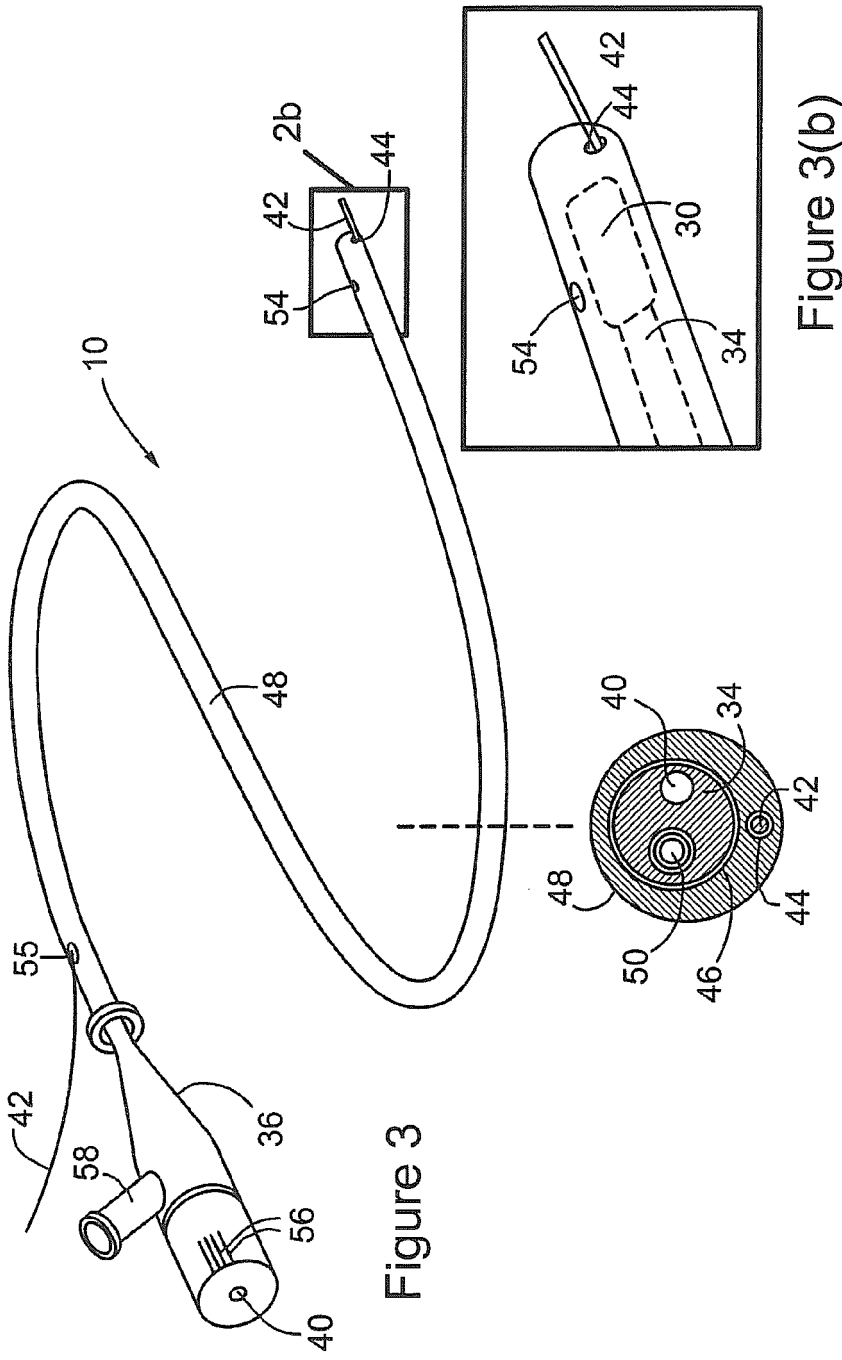
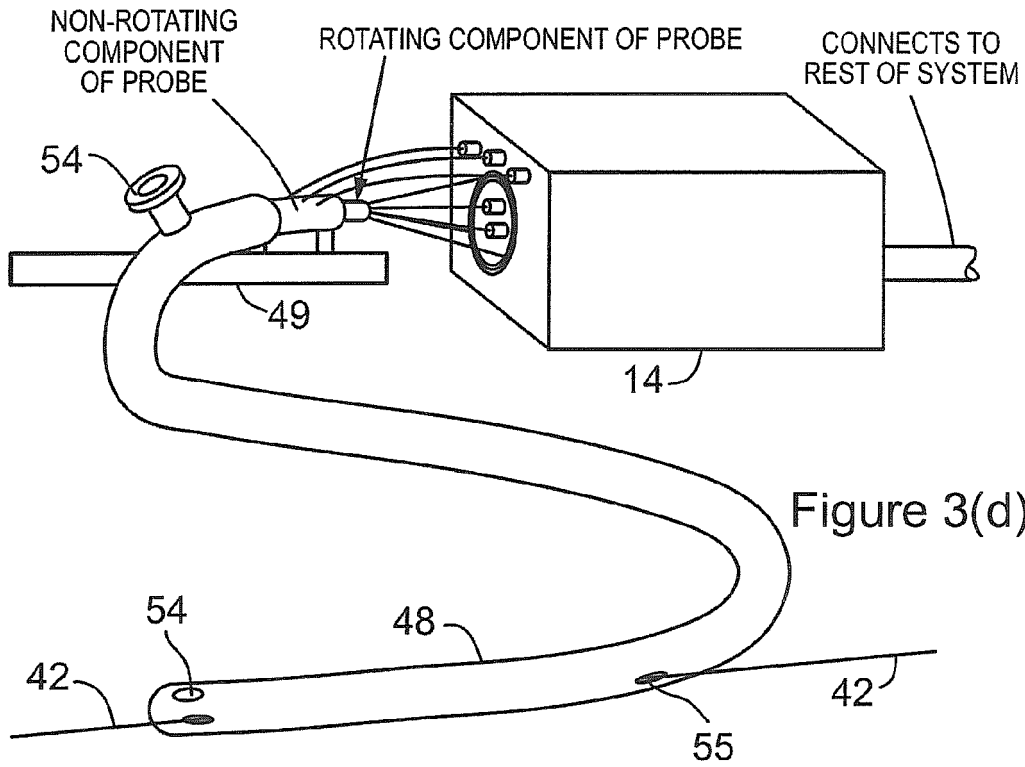
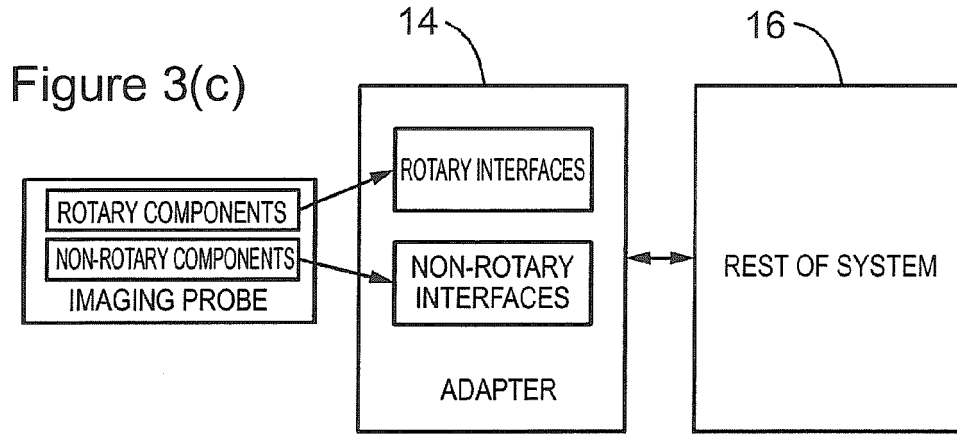

Figure 3

Figure 3(b)

Figure 3(a)

PRIOR ART



PRIOR ART

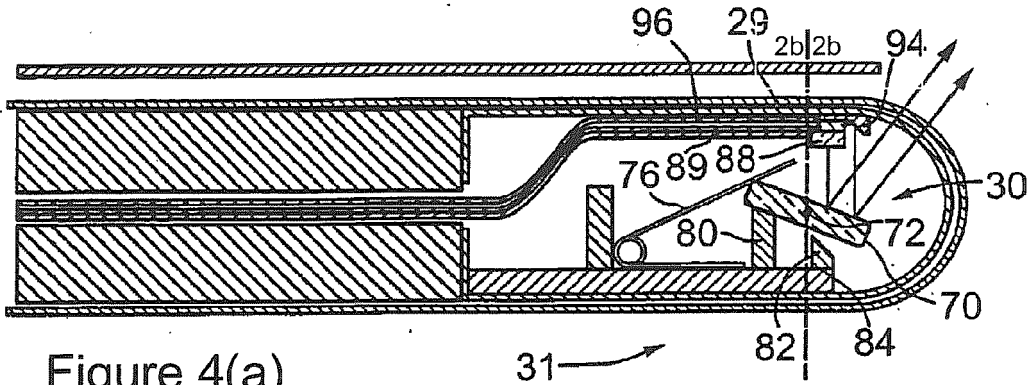

Figure 4(a)

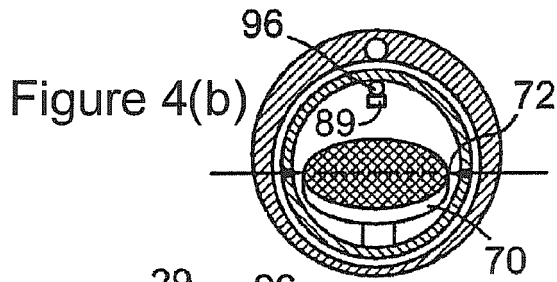

Figure 4(b)

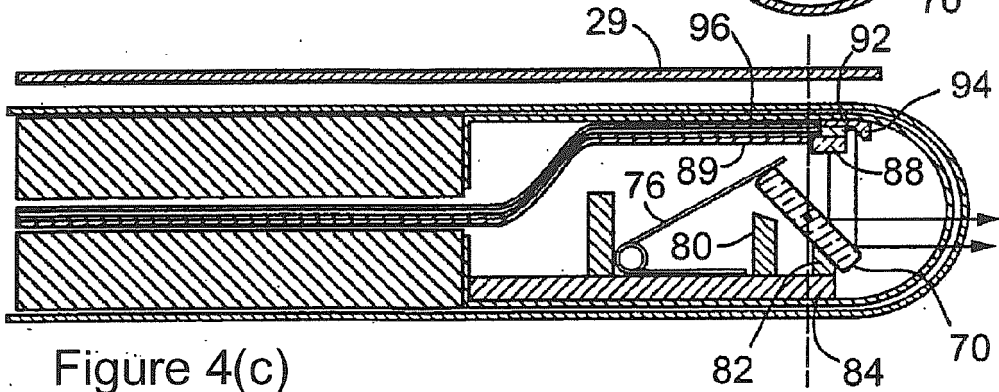

Figure 4(c)

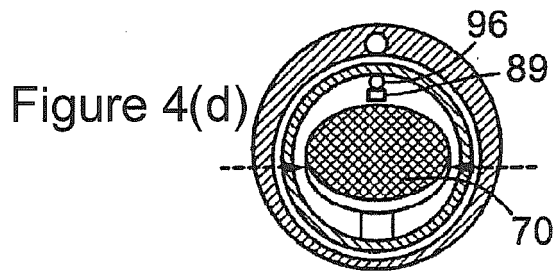
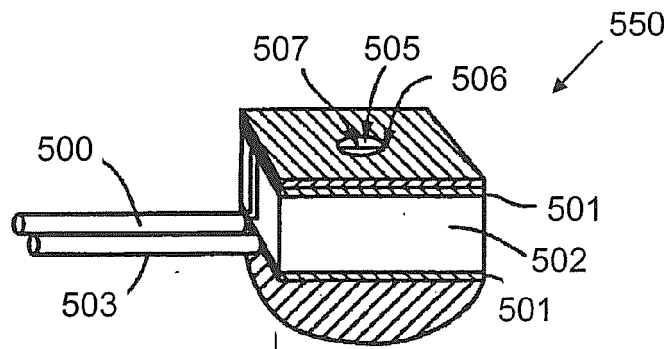
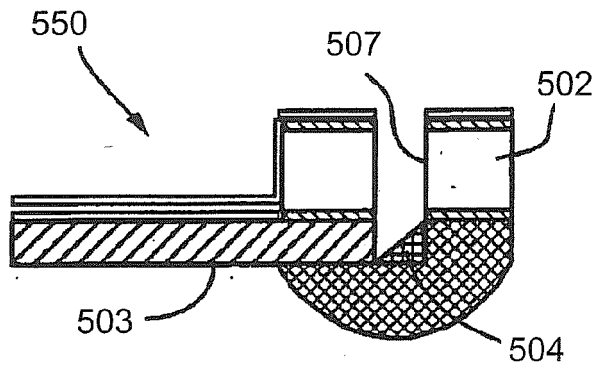

Figure 4(d)

PRIOR ART



(a)



(b)

PRIOR ART

Figure 5

7/9

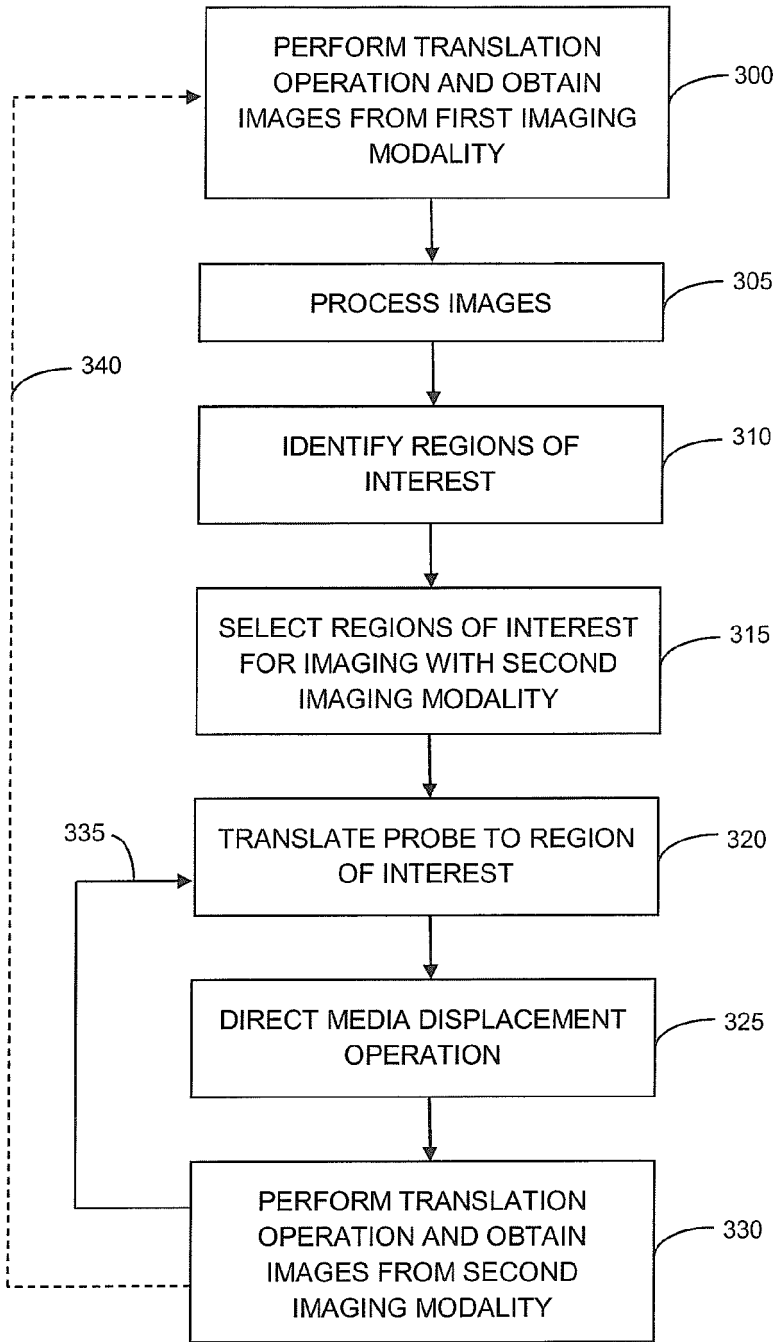

Figure 6

8/9

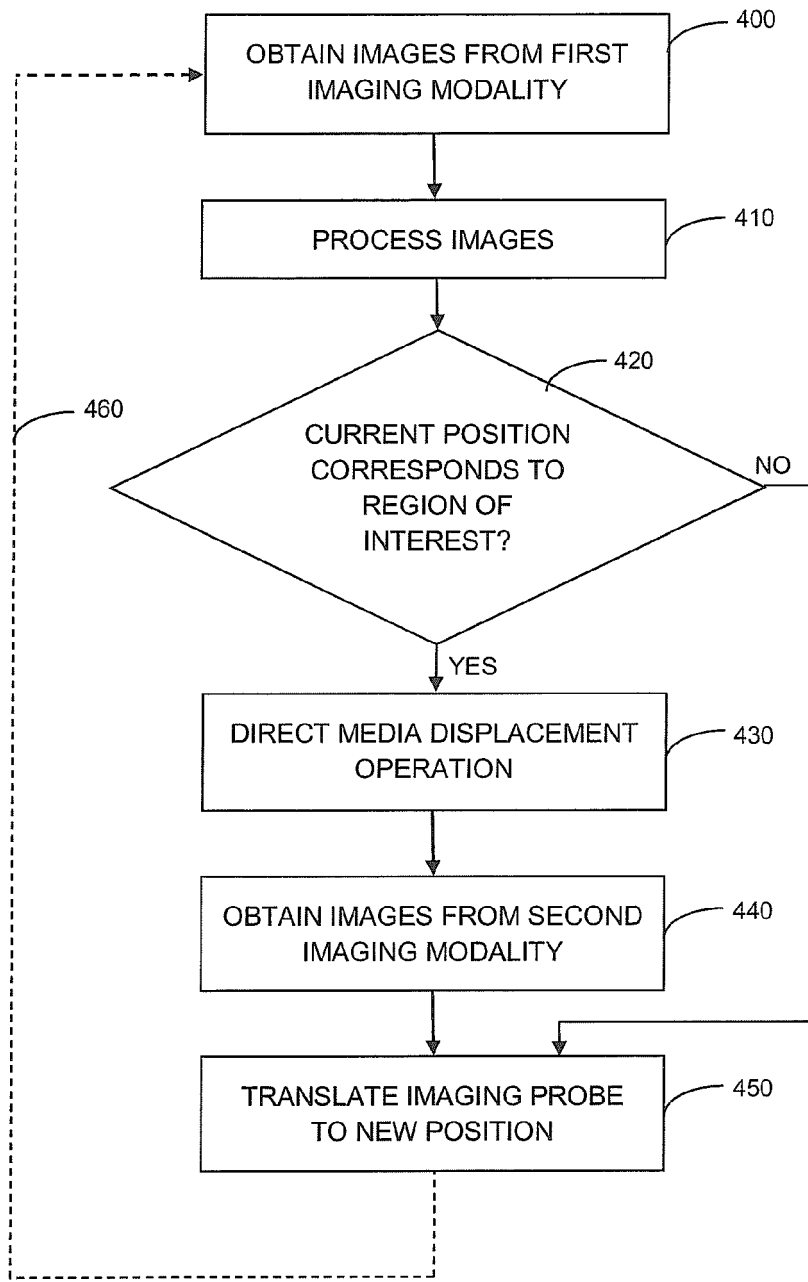

Figure 7

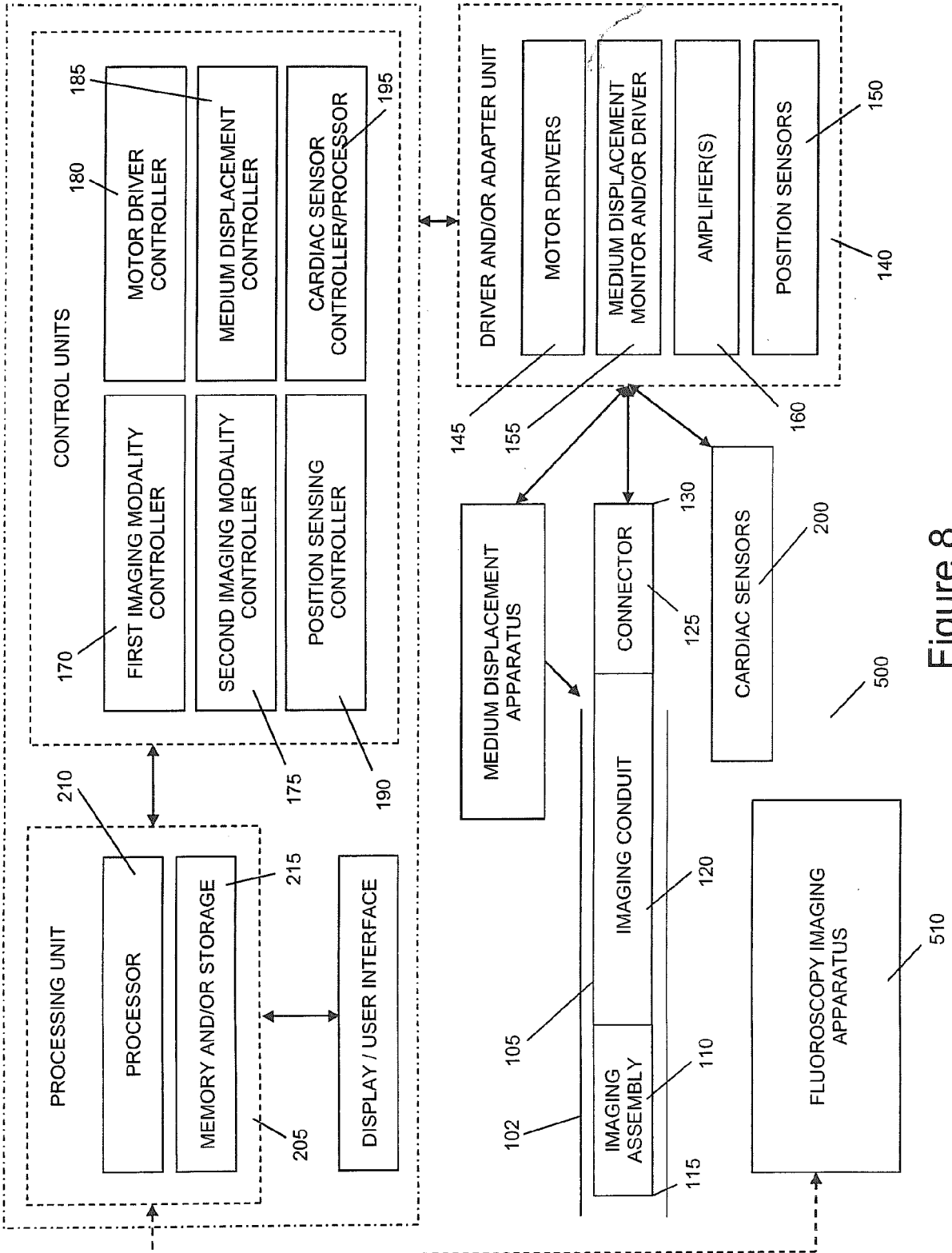

Figure 8

INTERNATIONAL SEARCH REPORT

International application No.
PCT/CA2011/050693

A. CLASSIFICATION OF SUBJECT MATTER
 IPC: **A61B 5/00** (2006.01) , **A61B 8/12** (2006.01) , **A61B 8/13** (2006.01) , **A61M 5/00** (2006.01) ,
G06T 7/00 (2006.01)
 According to International Patent Classification (IPC) or to both national classification and IPC

B. FIELDS SEARCHED
 Minimum documentation searched (classification system followed by classification symbols)
 IPC: **A61B 5/00** (2006.01) , **A61B 8/12** (2006.01) , **A61B 8/13** (2006.01) , **A61M 5/00** (2006.01) ,
G06T 7/00 (2006.01)

Documentation searched other than minimum documentation to the extent that such documents are included in the fields searched

Electronic database(s) consulted during the international search (name of database(s) and, where practicable, search terms used)
 Databases: CPD (Canadian Patent Database), IEEE Xplore, Total Patent, Google Patents
 Keywords: imaging , modality, probe, compatible, medium, processing, minimally, invasive, displacement, control, spatially, torque, cable, blood, vessel

C. DOCUMENTS CONSIDERED TO BE RELEVANT

Category*	Citation of document, with indication, where appropriate, of the relevant passages	Relevant to claim No.
Y	US20070135803 A1 14 Jun. 2007 (14-06-2007) by Belson ** see abstract, entire document**	1-123
Y	US 7352339 B2 1 Apr. 2008 (01-04-2008) by Morgan et al. ** see abstract, entire document**	1-123

Further documents are listed in the continuation of Box C. See patent family annex.

* Special categories of cited documents :	"T" later document published after the international filing date or priority date and not in conflict with the application but cited to understand the principle or theory underlying the invention
"A" document defining the general state of the art which is not considered to be of particular relevance	"X" document of particular relevance; the claimed invention cannot be considered novel or cannot be considered to involve an inventive step when the document is taken alone
"E" earlier application or patent but published on or after the international filing date	"Y" document of particular relevance; the claimed invention cannot be considered to involve an inventive step when the document is combined with one or more other such documents, such combination being obvious to a person skilled in the art
"L" document which may throw doubts on priority claim(s) or which is cited to establish the publication date of another citation or other special reason (as specified)	"&" document member of the same patent family
"O" document referring to an oral disclosure, use, exhibition or other means	
"P" document published prior to the international filing date but later than the priority date claimed	

Date of the actual completion of the international search 13 March 2012 (13-03-2012)	Date of mailing of the international search report 16 March 2012 (16-03-2012)
---	--

Name and mailing address of the ISA/CA Canadian Intellectual Property Office Place du Portage I, C114 - 1st Floor, Box PCT 50 Victoria Street Gatineau, Quebec K1A 0C9 Facsimile No.: 001-819-953-2476	Authorized officer Karen Oprea (819) 934-2668
---	---

Box No. II Observations where certain claims were found unsearchable (Continuation of item 2 of the first sheet)

This international search report has not been established in respect of certain claims under Article 17(2)(a) for the following reasons :

1. Claim Nos. : 1-123
because they relate to subject matter not required to be searched by this Authority, namely :

Claims 1-123 are directed to an invasive method for treatment of the human or animal body by surgery or therapy which the International Search Authority is not required to search. However, this Authority has carried out a search based on the alleged effects or purposes/uses of the device/system defined in claims 1-123.
2. Claim Nos. :
because they relate to parts of the international application that do not comply with the prescribed requirements to such an extent that no meaningful international search can be carried out, specifically :
3. Claim Nos. :
because they are dependent claims and are not drafted in accordance with the second and third sentences of Rule 6.4(a).

Box No. III Observations where unity of invention is lacking (Continuation of item 3 of first sheet)

This International Searching Authority found multiple inventions in this international application, as follows :

1. As all required additional search fees were timely paid by the applicant, this international search report covers all searchable claims.
2. As all searchable claims could be searched without effort justifying additional fees, this Authority did not invite payment of additional fees.
3. As only some of the required additional search fees were timely paid by the applicant, this international search report covers only those claims for which fees were paid, specifically claim Nos. :
4. No required additional search fees were timely paid by the applicant. Consequently, this international search report is restricted to the invention first mentioned in the claims; it is covered by claim Nos. :

- Remark on Protest**
- The additional search fees were accompanied by the applicant's protest and, where applicable, the payment of a protest fee.
 - The additional search fees were accompanied by the applicant's protest but the applicable protest fee was not paid within the time limit specified in the invitation.
 - No protest accompanied the payment of additional search fees.

INTERNATIONAL SEARCH REPORT
Information on patent family members

International application No.
PCT/CA2011/050693

Patent Document Cited in Search Report	Publication Date	Patent Family Member(s)	Publication Date
US2007135803A1	14 June 2007 (14-06-2007)	EP1931237A2	18 June 2008 (18-06-2008)
		JP2009507617A	26 February 2009 (26-02-2009)
		JP2010069314A	02 April 2010 (02-04-2010)
		WO2007033379A2	22 March 2007 (22-03-2007)
		WO2007033379A3	28 May 2009 (28-05-2009)
US7352339B2	01 April 2008 (01-04-2008)	US2003076281A1	24 April 2003 (24-04-2003)
		AT222013T	15 August 2002 (15-08-2002)
		AT301802T	15 August 2005 (15-08-2005)
		AT308869T	15 November 2005 (15-11-2005)
		AT416597T	15 December 2008 (15-12-2008)
		AT431065T	15 May 2009 (15-05-2009)
		AT434152T	15 July 2009 (15-07-2009)
		AT455451T	15 January 2010 (15-01-2010)
		AT464771T	15 April 2010 (15-04-2010)
		AT466309T	15 May 2010 (15-05-2010)
		AT467332T	15 May 2010 (15-05-2010)
		AT500714T	15 March 2011 (15-03-2011)
		AT520284T	15 August 2011 (15-08-2011)
		AT539593T	15 January 2012 (15-01-2012)
		AU757000B2	30 January 2003 (30-01-2003)
		AU1782501A	30 May 2001 (30-05-2001)
		AU1924199A	05 July 1999 (05-07-1999)
		AU3947002A	27 May 2002 (27-05-2002)
		AU4148402A	11 June 2002 (11-06-2002)
		AU5312999A	17 January 2000 (17-01-2000)
		AU5913401A	07 November 2001 (07-11-2001)
		AU6347300A	30 January 2001 (30-01-2001)
		AU7001801A	02 January 2002 (02-01-2002)
		AU7369401A	13 February 2002 (13-02-2002)
		AU7718501A	13 February 2002 (13-02-2002)
		AU7730800A	30 April 2001 (30-04-2001)
		AU8539801A	18 February 2002 (18-02-2002)
		AU8540801A	18 February 2002 (18-02-2002)
		AU8865901A	13 March 2002 (13-03-2002)
		AU9111101A	02 April 2002 (02-04-2002)
		AU9206098A	16 March 1999 (16-03-1999)
		AU2002238113A1	12 September 2002 (12-09-2002)
		AU2002310434A1	23 December 2002 (23-12-2002)
		AU2002346802A1	16 December 2002 (16-12-2002)
		AU2002360721A1	09 July 2003 (09-07-2003)
		AU2003203584B2	16 March 2006 (16-03-2006)
		AU2003210890A1	02 September 2003 (02-09-2003)
		AU2003210890A8	02 September 2003 (02-09-2003)
		AU2003237827A1	11 November 2003 (11-11-2003)
		AU2003265764A1	19 March 2004 (19-03-2004)
		AU2003268540A1	29 March 2004 (29-03-2004)
		AU2003279157A1	23 April 2004 (23-04-2004)
AU2003279157A8	23 April 2004 (23-04-2004)		
AU2004200183A1	12 February 2004 (12-02-2004)		
AU2004200183B2	21 June 2007 (21-06-2007)		
AU2004300444A1	30 June 2005 (30-06-2005)		
AU2004300444B2	11 June 2009 (11-06-2009)		
AU2005222987A1	29 September 2005 (29-09-2005)		
AU2005222987B2	23 July 2009 (23-07-2009)		
AU2005222987B9	22 October 2009 (22-10-2009)		
AU2006202217A1	15 June 2006 (15-06-2006)		
AU2006202217B2	09 October 2008 (09-10-2008)		
AU2007216901A1	11 October 2007 (11-10-2007)		
AU2007216901B2	17 July 2008 (17-07-2008)		
CA2302227A1	04 March 1999 (04-03-1999)		
CA2302227C	27 July 2004 (27-07-2004)		

INTERNATIONAL SEARCH REPORT

International application No.
PCT/CA2011/050693

CA2314163A1	24 June 1999 (24-06-1999)
CA2314163C	23 September 2008 (23-09-2008)
CA2336184A1	06 January 2000 (06-01-2000)
CA2466717A1	04 March 1999 (04-03-1999)
CA2466717C	26 January 2010 (26-01-2010)
CA2552683A1	30 June 2005 (30-06-2005)
CA2552683C	03 May 2011 (03-05-2011)
CA2559718A1	29 September 2005 (29-09-2005)
CA2579196A1	23 March 2006 (23-03-2006)
CA2579196C	22 June 2010 (22-06-2010)
CA2591133A1	29 June 2006 (29-06-2006)
CA2591205A1	06 July 2006 (06-07-2006)
CA2730210A1	29 September 2005 (29-09-2005)
CN1809867A	26 July 2006 (26-07-2006)
DE60021911D1	15 September 2005 (15-09-2005)
DE60021911T2	18 May 2006 (18-05-2006)
DE60023730D1	08 December 2005 (08-12-2005)
DE60023730T2	06 July 2006 (06-07-2006)
DE60042177D1	18 June 2009 (18-06-2009)
DE60045697D1	14 April 2011 (14-04-2011)
DE60139022D1	30 July 2009 (30-07-2009)
DE60141857D1	27 May 2010 (27-05-2010)
DE60236280D1	17 June 2010 (17-06-2010)
DE60325042D1	15 January 2009 (15-01-2009)
DE60330967D1	04 March 2010 (04-03-2010)
DE69807092D1	12 September 2002 (12-09-2002)
DE69807092T2	08 May 2003 (08-05-2003)
DE602004026908D1	10 June 2010 (10-06-2010)
DK1337784T3	19 October 2009 (19-10-2009)
DK1422975T3	02 August 2010 (02-08-2010)
DK1502483T3	23 March 2009 (23-03-2009)
DK1535495T3	11 October 2010 (11-10-2010)
EP1016062A1	05 July 2000 (05-07-2000)
EP1016062B1	07 August 2002 (07-08-2002)
EP1040398A2	04 October 2000 (04-10-2000)
EP1090459A2	11 April 2001 (11-04-2001)
EP1172748A2	16 January 2002 (16-01-2002)
EP1172748A3	10 March 2004 (10-03-2004)
EP1195740A2	10 April 2002 (10-04-2002)
EP1195740A3	22 January 2003 (22-01-2003)
EP1224843A1	24 July 2002 (24-07-2002)
EP1224845A1	24 July 2002 (24-07-2002)
EP1224845B1	02 November 2005 (02-11-2005)
EP1234140A2	28 August 2002 (28-08-2002)
EP1234140B1	10 August 2005 (10-08-2005)
EP1287724A1	05 March 2003 (05-03-2003)
EP1295515A1	26 March 2003 (26-03-2003)
EP1295515B1	28 December 2011 (28-12-2011)
EP1337784A2	27 August 2003 (27-08-2003)
EP1337784B1	17 June 2009 (17-06-2009)
EP1340412A2	03 September 2003 (03-09-2003)
EP1356610A2	29 October 2003 (29-10-2003)
EP1388276A2	11 February 2004 (11-02-2004)
EP1388276B1	10 August 2011 (10-08-2011)
EP1393599A2	03 March 2004 (03-03-2004)
EP1393599B1	05 May 2010 (05-05-2010)
EP1395975A2	10 March 2004 (10-03-2004)
EP1422975A1	26 May 2004 (26-05-2004)
EP1422975A8	16 January 2008 (16-01-2008)
EP1422975B1	14 April 2010 (14-04-2010)
EP1422975B9	30 March 2011 (30-03-2011)
EP1428415A1	16 June 2004 (16-06-2004)
EP1459600A2	22 September 2004 (22-09-2004)
EP1474633A2	10 November 2004 (10-11-2004)
EP1501763A2	02 February 2005 (02-02-2005)
EP1502483A1	02 February 2005 (02-02-2005)
EP1502483B1	03 December 2008 (03-12-2008)
EP1535495A2	01 June 2005 (01-06-2005)
EP1535495B1	13 January 2010 (13-01-2010)
EP1610593A2	28 December 2005 (28-12-2005)
EP1610593A3	23 May 2007 (23-05-2007)
EP1620843A2	01 February 2006 (01-02-2006)
EP1624728A1	08 February 2006 (08-02-2006)

INTERNATIONAL SEARCH REPORT

International application No.
PCT/CA2011/050693

EP1610593A3	23 May 2007 (23-05-2007)
EP1620843A2	01 February 2006 (01-02-2006)
EP1624728A1	08 February 2006 (08-02-2006)
EP1624728B1	06 May 2009 (06-05-2009)
EP1687692A2	09 August 2006 (09-08-2006)
EP1687692A4	22 April 2009 (22-04-2009)
EP1687692B1	28 April 2010 (28-04-2010)
EP1704752A2	27 September 2006 (27-09-2006)
EP1704752A4	23 September 2009 (23-09-2009)
EP1729615A2	13 December 2006 (13-12-2006)
EP1731004A2	13 December 2006 (13-12-2006)
EP1754121A2	21 February 2007 (21-02-2007)
EP1800054A2	27 June 2007 (27-06-2007)
EP1831866A2	12 September 2007 (12-09-2007)
EP1849152A2	31 October 2007 (31-10-2007)
EP1887836A2	13 February 2008 (13-02-2008)
EP1887836A3	28 April 2010 (28-04-2010)
EP1887836B1	07 March 2012 (07-03-2012)
EP2139299A2	30 December 2009 (30-12-2009)
EP2139299A3	20 January 2010 (20-01-2010)
EP2139299B1	02 March 2011 (02-03-2011)
EP2203032A2	30 June 2010 (30-06-2010)
EP2203032A3	03 November 2010 (03-11-2010)
EP2364067A2	07 September 2011 (07-09-2011)
EP2364067A3	14 December 2011 (14-12-2011)
ES2182358T3	01 March 2003 (01-03-2003)
ES2251396T3	01 May 2006 (01-05-2006)
ES2253274T3	01 June 2006 (01-06-2006)
ES2320644T3	27 May 2009 (27-05-2009)
ES2326744T3	19 October 2009 (19-10-2009)
ES2327612T3	02 November 2009 (02-11-2009)
ES2339243T3	18 May 2010 (18-05-2010)
ES2343964T3	13 August 2010 (13-08-2010)
ES2344257T3	23 August 2010 (23-08-2010)
ES2345540T3	27 September 2010 (27-09-2010)
ES2361969T3	24 June 2011 (24-06-2011)
ES2371237T3	28 December 2011 (28-12-2011)
HK1025416A1	01 November 2002 (01-11-2002)
JP2004534355A	11 November 2004 (11-11-2004)
JP4173091B2	29 October 2008 (29-10-2008)
JP2005509245A	07 April 2005 (07-04-2005)
JP4208576B2	14 January 2009 (14-01-2009)
JP2003504829A	04 February 2003 (04-02-2003)
JP4230145B2	25 February 2009 (25-02-2009)
JP2004006253A	08 January 2004 (08-01-2004)
JP4230236B2	25 February 2009 (25-02-2009)
JP2005524960A	18 August 2005 (18-08-2005)
JP4347794B2	21 October 2009 (21-10-2009)
JP2005510007A	14 April 2005 (14-04-2005)
JP4351040B2	28 October 2009 (28-10-2009)
JP2008034385A	14 February 2008 (14-02-2008)
JP4451899B2	14 April 2010 (14-04-2010)
JP2008078162A	03 April 2008 (03-04-2008)
JP4474457B2	02 June 2010 (02-06-2010)
JP2005504411A	10 February 2005 (10-02-2005)
JP4518793B2	04 August 2010 (04-08-2010)
JP2005537613A	08 December 2005 (08-12-2005)
JP4625697B2	02 February 2011 (02-02-2011)
JP2005517278A	09 June 2005 (09-06-2005)
JP4652691B2	16 March 2011 (16-03-2011)
JP4718008B2	06 July 2011 (06-07-2011)
JP4773673B2	14 September 2011 (14-09-2011)
JP2001514432A	11 September 2001 (11-09-2001)
JP2002519989A	02 July 2002 (02-07-2002)
JP2003510856A	18 March 2003 (18-03-2003)
JP2003517705A	27 May 2003 (27-05-2003)
JP2003531467A	21 October 2003 (21-10-2003)
JP2004501497A	15 January 2004 (15-01-2004)
JP2004508162A	18 March 2004 (18-03-2004)
JP2004511878A	15 April 2004 (15-04-2004)
JP2004524650A	12 August 2004 (12-08-2004)

INTERNATIONAL SEARCH REPORT

International application No.
PCT/CA2011/050693

JP2004511878A	15 April 2004 (15-04-2004)
JP2004524650A	12 August 2004 (12-08-2004)
JP2004529455A	24 September 2004 (24-09-2004)
JP2004534356A	11 November 2004 (11-11-2004)
JP2005528733A	22 September 2005 (22-09-2005)
JP2007525690A	06 September 2007 (06-09-2007)
JP2007529872A	25 October 2007 (25-10-2007)
JP2009070832A	02 April 2009 (02-04-2009)
JP2009152213A	09 July 2009 (09-07-2009)
JP2009187951A	20 August 2009 (20-08-2009)
JP2009200046A	03 September 2009 (03-09-2009)
JP2011175976A	08 September 2011 (08-09-2011)
JP2011181507A	15 September 2011 (15-09-2011)
JP2011188738A	22 September 2011 (22-09-2011)
KR20060108757A	18 October 2006 (18-10-2006)
KR20060131985A	20 December 2006 (20-12-2006)
KR20080099352A	12 November 2008 (12-11-2008)
PT1422975E	09 July 2010 (09-07-2010)
PT1502483E	10 March 2009 (10-03-2009)
US6016038A	18 January 2000 (18-01-2000)
US6150774A	21 November 2000 (21-11-2000)
US6166496A	26 December 2000 (26-12-2000)
US6211626B1	03 April 2001 (03-04-2001)
US6292901B1	18 September 2001 (18-09-2001)
US6340868B1	22 January 2002 (22-01-2002)
US6459919B1	01 October 2002 (01-10-2002)
US6528954B1	04 March 2003 (04-03-2003)
US6548967B1	15 April 2003 (15-04-2003)
US2002047646A1	25 April 2002 (25-04-2002)
US6577080B2	10 June 2003 (10-06-2003)
US2002047628A1	25 April 2002 (25-04-2002)
US6608453B2	19 August 2003 (19-08-2003)
US2002101200A1	01 August 2002 (01-08-2002)
US6624597B2	23 September 2003 (23-09-2003)
US2002158583A1	31 October 2002 (31-10-2002)
US6717376B2	06 April 2004 (06-04-2004)
US2001028227A1	11 October 2001 (11-10-2001)
US6720745B2	13 April 2004 (13-04-2004)
US6774584B2	10 August 2004 (10-08-2004)
US2003057886A1	27 March 2003 (27-03-2003)
US6777891B2	17 August 2004 (17-08-2004)
US6781329B2	24 August 2004 (24-08-2004)
US2002057061A1	16 May 2002 (16-05-2002)
US6788011B2	07 September 2004 (07-09-2004)
US2002195975A1	26 December 2002 (26-12-2002)
US6801003B2	05 October 2004 (05-10-2004)
US6806659B1	19 October 2004 (19-10-2004)
US2002171365A1	21 November 2002 (21-11-2002)
US6869204B2	22 March 2005 (22-03-2005)
US2002047569A1	25 April 2002 (25-04-2002)
US6888322B2	03 May 2005 (03-05-2005)
US6897624B2	24 May 2005 (24-05-2005)
US6936978B2	30 August 2005 (30-08-2005)
US2003137258A1	24 July 2003 (24-07-2003)
US6965205B2	15 November 2005 (15-11-2005)
US6967448B2	22 November 2005 (22-11-2005)
US2004032226A1	19 February 2004 (19-02-2004)
US6969954B2	29 November 2005 (29-11-2005)
US6975079B2	13 December 2005 (13-12-2005)
US7014336B1	21 March 2006 (21-03-2006)
US7031920B2	18 April 2006 (18-04-2006)
US7038398B1	02 May 2006 (02-05-2006)
US2004212321A1	28 October 2004 (28-10-2004)
US7038399B2	02 May 2006 (02-05-2006)
US2004113568A1	17 June 2004 (17-06-2004)
US7042172B2	09 May 2006 (09-05-2006)
US2002070688A1	13 June 2002 (13-06-2002)
US2003214259A9	20 November 2003 (20-11-2003)

INTERNATIONAL SEARCH REPORT

International application No.
PCT/CA2011/050693

US7064498B2	20 June 2006 (20-06-2006)
US7113541B1	26 September 2006 (26-09-2006)
US2005041424A1	24 February 2005 (24-02-2005)
US7132785B2	07 November 2006 (07-11-2006)
US2004155609A1	12 August 2004 (12-08-2004)
US7132804B2	07 November 2006 (07-11-2006)
US2005062440A1	24 March 2005 (24-03-2005)
US7135824B2	14 November 2006 (14-11-2006)
US7139617B1	21 November 2006 (21-11-2006)
US2004090191A1	13 May 2004 (13-05-2004)
US7161311B2	09 January 2007 (09-01-2007)
US7161313B2	09 January 2007 (09-01-2007)
US2002145394A1	10 October 2002 (10-10-2002)
US7161556B2	09 January 2007 (09-01-2007)
US2004257007A1	23 December 2004 (23-12-2004)
US7180252B2	20 February 2007 (20-02-2007)
US7186003B2	06 March 2007 (06-03-2007)
US7187141B2	06 March 2007 (06-03-2007)
US2004160199A1	19 August 2004 (19-08-2004)
US7202613B2	10 April 2007 (10-04-2007)
US2004090787A1	13 May 2004 (13-05-2004)
US7204622B2	17 April 2007 (17-04-2007)
US2003011538A1	16 January 2003 (16-01-2003)
US7221104B2	22 May 2007 (22-05-2007)
US2002038157A1	28 March 2002 (28-03-2002)
US7228190B2	05 June 2007 (05-06-2007)
US2004212320A1	28 October 2004 (28-10-2004)
US7231060B2	12 June 2007 (12-06-2007)
US2005218838A1	06 October 2005 (06-10-2005)
US7233115B2	19 June 2007 (19-06-2007)
US2003028260A1	06 February 2003 (06-02-2003)
US7233831B2	19 June 2007 (19-06-2007)
US2003057887A1	27 March 2003 (27-03-2003)
US7242152B2	10 July 2007 (10-07-2007)
US2005047132A1	03 March 2005 (03-03-2005)
US7248239B2	24 July 2007 (24-07-2007)
US2004240890A1	02 December 2004 (02-12-2004)
US7253566B2	07 August 2007 (07-08-2007)
US2005030744A1	10 February 2005 (10-02-2005)
US7255457B2	14 August 2007 (14-08-2007)
US2005231133A1	20 October 2005 (20-10-2005)
US7256554B2	14 August 2007 (14-08-2007)
US2004178751A1	16 September 2004 (16-09-2004)
US7274160B2	25 September 2007 (25-09-2007)
US2004130909A1	08 July 2004 (08-07-2004)
US7300192B2	27 November 2007 (27-11-2007)
US2005036300A1	17 February 2005 (17-02-2005)
US2006262516A9	23 November 2006 (23-11-2006)
US7303300B2	04 December 2007 (04-12-2007)
US2003100837A1	29 May 2003 (29-05-2003)
US7308296B2	11 December 2007 (11-12-2007)
US2003222587A1	04 December 2003 (04-12-2003)
US7309965B2	18 December 2007 (18-12-2007)
US2005276053A1	15 December 2005 (15-12-2005)
US7344279B2	18 March 2008 (18-03-2008)
US2006285325A1	21 December 2006 (21-12-2006)
US7350936B2	01 April 2008 (01-04-2008)
US2006208667A1	21 September 2006 (21-09-2006)
US7352138B2	01 April 2008 (01-04-2008)
US2002078221A1	20 June 2002 (20-06-2002)
US7353071B2	01 April 2008 (01-04-2008)
US2006104058A1	18 May 2006 (18-05-2006)
US7354172B2	08 April 2008 (08-04-2008)
US2005253533A1	17 November 2005 (17-11-2005)
US7358679B2	15 April 2008 (15-04-2008)
US2005219872A1	06 October 2005 (06-10-2005)
US7358706B2	15 April 2008 (15-04-2008)
US2005116667A1	02 June 2005 (02-06-2005)
US7358929B2	15 April 2008 (15-04-2008)
US2002152045A1	17 October 2002 (17-10-2002)

US2002152045A1

17 October 2002 (17-10-2002)	
US7385359B2	10 June 2008 (10-06-2008)
US2004105261A1	03 June 2004 (03-06-2004)
US2006012987A9	19 January 2006 (19-01-2006)
US7387405B2	17 June 2008 (17-06-2008)
US2004212993A1	28 October 2004 (28-10-2004)
US7427840B2	23 September 2008 (23-09-2008)
US2005035728A1	17 February 2005 (17-02-2005)
US7449847B2	11 November 2008 (11-11-2008)
US2005151489A1	14 July 2005 (14-07-2005)
US7453217B2	18 November 2008 (18-11-2008)
US2005213352A1	29 September 2005 (29-09-2005)
US7459864B2	02 December 2008 (02-12-2008)
US2008012506A1	17 January 2008 (17-01-2008)
US7462997B2	09 December 2008 (09-12-2008)
US2006016960A1	26 January 2006 (26-01-2006)
US7482565B2	27 January 2009 (27-01-2009)
US2002130627A1	19 September 2002 (19-09-2002)
US7482764B2	27 January 2009 (27-01-2009)
US2007189026A1	16 August 2007 (16-08-2007)
US7495671B2	24 February 2009 (24-02-2009)
US2005248299A1	10 November 2005 (10-11-2005)
US7502034B2	10 March 2009 (10-03-2009)
US2006098077A1	11 May 2006 (11-05-2006)
US7515128B2	07 April 2009 (07-04-2009)
US2006109649A1	25 May 2006 (25-05-2006)
US7520634B2	21 April 2009 (21-04-2009)
US2005063194A1	24 March 2005 (24-03-2005)
US7525254B2	28 April 2009 (28-04-2009)
US2007291483A1	20 December 2007 (20-12-2007)
US7550931B2	23 June 2009 (23-06-2009)
US2007206375A1	06 September 2007 (06-09-2007)
US7550935B2	23 June 2009 (23-06-2009)
US2005213353A1	29 September 2005 (29-09-2005)
US7557521B2	07 July 2009 (07-07-2009)
US2007115665A1	24 May 2007 (24-05-2007)
US7572028B2	11 August 2009 (11-08-2009)
US2007236156A1	11 October 2007 (11-10-2007)
US7598681B2	06 October 2009 (06-10-2009)
US2007237284A1	11 October 2007 (11-10-2007)
US7598684B2	06 October 2009 (06-10-2009)
US2007188427A1	16 August 2007 (16-08-2007)
US7598686B2	06 October 2009 (06-10-2009)
US2008204268A1	28 August 2008 (28-08-2008)
US7642730B2	05 January 2010 (05-01-2010)
US2006022214A1	02 February 2006 (02-02-2006)
US7646029B2	12 January 2010 (12-01-2010)
US2008130267A1	05 June 2008 (05-06-2008)
US7652436B2	26 January 2010 (26-01-2010)
US2005218870A1	06 October 2005 (06-10-2005)
US7659673B2	09 February 2010 (09-02-2010)
US2007195526A1	23 August 2007 (23-08-2007)
US7659674B2	09 February 2010 (09-02-2010)
US2006158881A1	20 July 2006 (20-07-2006)
US7710369B2	04 May 2010 (04-05-2010)
US2008012502A1	17 January 2008 (17-01-2008)
US7737643B2	15 June 2010 (15-06-2010)
US2003057884A1	27 March 2003 (27-03-2003)
US7764026B2	27 July 2010 (27-07-2010)
US2007086754A1	19 April 2007 (19-04-2007)
US7809448B2	05 October 2010 (05-10-2010)
US2005047134A1	03 March 2005 (03-03-2005)
US7845823B2	07 December 2010 (07-12-2010)
US2007115658A1	24 May 2007 (24-05-2007)
US7959320B2	14 June 2011 (14-06-2011)
US2010148689A1	17 June 2010 (17-06-2010)
US8013281B2	06 September 2011 (06-09-2011)
US2010171145A1	08 July 2010 (08-07-2010)
US8080819B2	20 December 2011 (20-12-2011)

US2002043938A1	18 April 2002 (18-04-2002)
US2002044066A1	18 April 2002 (18-04-2002)
US2002048169A1	25 April 2002 (25-04-2002)
US2003206411A9	06 November 2003 (06-11-2003)
US2002074559A1	20 June 2002 (20-06-2002)
US2002101197A1	01 August 2002 (01-08-2002)
US2002113555A1	22 August 2002 (22-08-2002)
US2002153851A1	24 October 2002 (24-10-2002)
US2002163316A1	07 November 2002 (07-11-2002)
US2002171377A1	21 November 2002 (21-11-2002)
US2002171378A1	21 November 2002 (21-11-2002)
US2002176259A1	28 November 2002 (28-11-2002)
US2003057890A1	27 March 2003 (27-03-2003)
US2003133292A1	17 July 2003 (17-07-2003)
US2004052076A1	18 March 2004 (18-03-2004)
US2005040774A1	24 February 2005 (24-02-2005)
US2005041161A1	24 February 2005 (24-02-2005)
US2005044617A1	03 March 2005 (03-03-2005)
US2005099824A1	12 May 2005 (12-05-2005)
US2005174473A1	11 August 2005 (11-08-2005)
US2005236998A1	27 October 2005 (27-10-2005)
US2005275626A1	15 December 2005 (15-12-2005)
US2005285547A1	29 December 2005 (29-12-2005)
US2006002110A1	05 January 2006 (05-01-2006)
US2006050509A9	09 March 2006 (09-03-2006)
US2006076908A1	13 April 2006 (13-04-2006)
US2006152172A9	13 July 2006 (13-07-2006)
US2006221606A1	05 October 2006 (05-10-2006)
US2007047227A1	01 March 2007 (01-03-2007)
US2007086912A1	19 April 2007 (19-04-2007)
US2007153514A1	05 July 2007 (05-07-2007)
US2007258240A1	08 November 2007 (08-11-2007)
US2008140231A1	12 June 2008 (12-06-2008)
US2008183081A1	31 July 2008 (31-07-2008)
US2008215391A1	04 September 2008 (04-09-2008)
US2010127634A1	27 May 2010 (27-05-2010)
WO0001067A2	06 January 2000 (06-01-2000)
WO0001067A3	16 March 2000 (16-03-2000)
WO0105195A1	18 January 2001 (18-01-2001)
WO0124584A1	05 April 2001 (05-04-2001)
WO0136864A2	25 May 2001 (25-05-2001)
WO0136864A3	22 November 2001 (22-11-2001)
WO0182657A1	01 November 2001 (01-11-2001)
WO0199475A1	27 December 2001 (27-12-2001)
WO0210847A2	07 February 2002 (07-02-2002)
WO0210847A3	18 September 2003 (18-09-2003)
WO0211497A1	07 February 2002 (07-02-2002)
WO0212127A2	14 February 2002 (14-02-2002)
WO0212127A3	09 December 2004 (09-12-2004)
WO0213490A2	14 February 2002 (14-02-2002)
WO0213490A3	31 October 2002 (31-10-2002)
WO0218913A2	07 March 2002 (07-03-2002)
WO0218913A3	27 February 2003 (27-02-2003)
WO0225842A2	28 March 2002 (28-03-2002)
WO0225842A3	28 August 2003 (28-08-2003)
WO0240921A2	23 May 2002 (23-05-2002)
WO0240921A3	21 November 2002 (21-11-2002)
WO0240921A9	06 February 2003 (06-02-2003)
WO0245467A2	06 June 2002 (06-06-2002)
WO0245467A3	19 September 2002 (19-09-2002)
WO0245467A9	31 July 2003 (31-07-2003)
WO9910867A1	04 March 1999 (04-03-1999)
WO9931560A2	24 June 1999 (24-06-1999)
WO9931560A3	02 September 1999 (02-09-1999)
WO9931560A8	07 October 1999 (07-10-1999)
WO02061330A2	08 August 2002 (08-08-2002)
WO02061330A8	13 February 2003 (13-02-2003)
WO02069306A2	06 September 2002 (06-09-2002)

INTERNATIONAL SEARCH REPORT

International application No.
PCT/CA2011/050693

WO02091805A2

14 November 2002 (14-11-2002)

WO02091805A3	24 April 2003 (24-04-2003)
WO02098182A2	05 December 2002 (05-12-2002)
WO02098182A3	08 May 2003 (08-05-2003)
WO02098183A1	05 December 2002 (05-12-2002)
WO02099780A2	12 December 2002 (12-12-2002)
WO02099780A3	31 July 2003 (31-07-2003)
WO02101702A2	19 December 2002 (19-12-2002)
WO02101702A3	01 May 2003 (01-05-2003)
WO02101702A9	10 July 2003 (10-07-2003)
WO03024269A1	27 March 2003 (27-03-2003)
WO03026358A1	27 March 2003 (27-03-2003)
WO03055273A2	03 July 2003 (03-07-2003)
WO03055273A3	04 December 2003 (04-12-2003)
WO03067934A2	14 August 2003 (14-08-2003)
WO03067934A3	05 February 2004 (05-02-2004)
WO03096761A1	20 November 2003 (20-11-2003)
WO2004021747A2	11 March 2004 (11-03-2004)
WO2004021747A3	01 July 2004 (01-07-2004)
WO2004023850A2	8 March 2004 (18-03-2004)
WO2004032572A2	15 April 2004 (15-04-2004)
WO2004032572A3	10 June 2004 (10-06-2004)
WO2004080291A2	23 September 2004 (23-09-2004)
WO2004080291A3	28 July 2005 (28-07-2005)
WO2004094896A2	04 November 2004 (04-11-2004)
WO2004094896A3	22 September 2005 (22-09-2005)
WO2005012997A2	10 February 2005 (10-02-2005)
WO2005012997A3	14 July 2005 (14-07-2005)
WO2005052751A2	09 June 2005 (09-06-2005)
WO2005052751A3	23 November 2006 (23-11-2006)
WO2005060309A2	30 June 2005 (30-06-2005)
WO2005060309A3	31 December 2008 (31-12-2008)
WO2005084339A2	15 September 2005 (15-09-2005)
WO2005084339A3	28 December 2006 (28-12-2006)
WO2005089293A2	29 September 2005 (29-09-2005)
WO2005089293A3	14 December 2006 (14-12-2006)
WO2005089309A2	29 September 2005 (29-09-2005)
WO2005089309A3	22 December 2005 (22-12-2005)
WO2006023149A2	02 March 2006 (02-03-2006)
WO2006023149A3	30 April 2009 (30-04-2009)
WO2006031753A2	23 March 2006 (23-03-2006)
WO2006031753A3	19 April 2007 (19-04-2007)
WO2006069002A2	29 June 2006 (29-06-2006)
WO2006069002A3	26 October 2006 (26-10-2006)
WO2006069117A2	29 June 2006 (29-06-2006)
WO2006069117A3	12 April 2007 (12-04-2007)
WO2006071628A2	06 July 2006 (06-07-2006)
WO2006071628A3	03 May 2007 (03-05-2007)

专利名称(译)	用于在微创手术期间改善可视化的系统和方法		
公开(公告)号	EP2637555A1	公开(公告)日	2013-09-18
申请号	EP2011840203	申请日	2011-11-08
[标]申请(专利权)人(译)	COLIBRI TECH		
申请(专利权)人(译)	COLIBRI科技股份有限公司.		
当前申请(专利权)人(译)	COLIBRI科技股份有限公司.		
[标]发明人	COURTNEY BRIAN THIND AMANDEEP		
发明人	COURTNEY, BRIAN THIND, AMANDEEP		
IPC分类号	A61B5/00 A61B8/12 A61B8/13 A61M5/00 G06T7/00 A61B5/0402 A61B5/06 A61B8/00 A61B18/00 A61B18/24 A61B19/00		
CPC分类号	A61B5/0035 A61B5/0066 A61B5/0084 A61B5/0402 A61B5/065 A61B5/6852 A61B5/6876 A61B5/7264 A61B8/12 A61B8/4245 A61B8/4416 A61B8/445 A61B18/24 A61B2090/364 G06T7/0012 G06T2207 /10048 G06T2207/10101 G06T2207/10132 G06T2207/30101 G06T7/32 A61B5/0073 A61B5/0095 A61B6/03 A61M5/007		
优先权	61/411225 2010-11-08 US		
其他公开文献	EP2637555A4		
外部链接	Espacenet		

摘要(译)

提供了用于以自动或半自动方式执行微创手术的系统和方法，其中采用具有与腔内介质的存在相容的成像模态的成像探针来记录经处理以识别感兴趣区域的图像。在随后的微创手术期间引导中等位移手术，该手术受益于管腔内介质的移位。微创手术可以包括用第二成像模态记录图像，或者可以是治疗性治疗。该方法可以实时执行，其中从第一成像模态获得的图像被实时处理以确定是否要在给定位置执行微创操作。