

(19) World Intellectual Property Organization
International Bureau



(43) International Publication Date
4 September 2008 (04.09.2008)

PCT

(10) International Publication Number
WO 2008/106590 A2

(51) International Patent Classification:
F21V 21/40 (2006.01)

Laguna Niguel, CA 92677 (US). **CHONG, Lawrence** [US/US]; 333 10th Street, Seal Beach, CA 90740 (US). **HUMAYUN, Mark** [US/US]; 2757 Sleepy Hollow Place, Glendale, CA 91205 (US).

(21) International Application Number:
PCT/US2008/055277

(74) Agents: **KUSMER, Toby, H.** et al.; McDermott Will & Emery LLP, 28 State Street, Boston, MA 02109 (US).

(22) International Filing Date:
28 February 2008 (28.02.2008)

(25) Filing Language: English

(81) Designated States (unless otherwise indicated, for every kind of national protection available): AE, AG, AL, AM, AO, AT, AU, AZ, BA, BB, BG, BH, BR, BW, BY, BZ, CA, CH, CN, CO, CR, CU, CZ, DE, DK, DM, DO, DZ, EC, EE, EG, ES, FI, GB, GD, GE, GH, GM, GT, HN, HR, HU, ID, IL, IN, IS, JP, KE, KG, KM, KN, KP, KR, KZ, LA, LC, LK, LR, LS, LT, LU, LY, MA, MD, ME, MG, MK, MN, MW, MX, MY, MZ, NA, NG, NI, NO, NZ, OM, PG, PH, PL, PT, RO, RS, RU, SC, SD, SE, SG, SK, SL, SM, SV, SY, TJ, TM, TN, TR, TT, TZ, UA, UG, US, UZ, VC, VN, ZA, ZM, ZW.

(26) Publication Language: English

(30) Priority Data:
60/892,028 28 February 2007 (28.02.2007) US

(71) Applicant (for all designated States except US): **DO-HENY EYE INSTITUTE** [US/US]; 1450 San Pablo Street, #3000, Los Angeles, CA 90033 (US).

(72) Inventors; and

(84) Designated States (unless otherwise indicated, for every kind of regional protection available): ARIPO (BW, GH, GM, KE, LS, MW, MZ, NA, SD, SL, SZ, TZ, UG, ZM, ZW), Eurasian (AM, AZ, BY, KG, KZ, MD, RU, TJ, TM), European (AT, BE, BG, CH, CY, CZ, DE, DK, EE, ES, FI, FR, GB, GR, HR, HU, IE, IS, IT, LT, LU, LV, MC, MT, NL, NO, PL, PT, RO, SE, SI, SK, TR), OAPI (BF, BJ, CF, CG, CI, CM, GA, GN, GQ, GW, ML, MR, NE, SN, TD, TG).

(75) Inventors/Applicants (for US only): **BHADRI, Prashant, R.** [IN/US]; 9050 Carron Drive, Apt. 374, Pico Rivera, CA 90660 (US). **DEBOER, Charles** [US/US]; 65A South El Nids, Pasadena, CA 91107 (US). **MC-CORMICK, Matthew** [US/US]; 39478 Canyon Drive, Forest Falls, CA 92339 (US). **MAGALHAES, Octaviano** [BR/US]; 200 South Madison Avenue, #6, Pasadena, CA 91101 (US). **LESCOULIE, Jay** [US/US]; 2401 Via Anacapa, Palos Verde, CA 90274 (US). **BARNES, Aaron** [US/US]; 5360 42nd Place, N.W., Washington, DC 20015 (US). **KERNS, Ralph** [US/US]; 29662 Teracuga,

Published:
— without international search report and to be republished upon receipt of that report

(54) Title: PORTABLE HANDHELD ILLUMINATION SYSTEM

HANDHELD ILLUMINATION SYSTEM

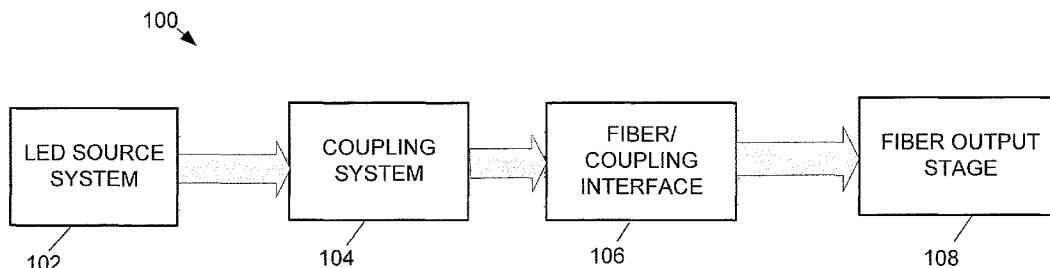

FIG. 1

(57) Abstract: Illumination systems are described that can include one or more light sources, which can include LEDs, one or more lenses, and one or more optical fibers. A handheld, portable, and surgical intraocular illumination system is disclosed that is disposable, low-cost, and efficient. A surgeon can have direct control of turning the illuminator on and off and adjusting the intensity via a simple control ergonomically placed on the handpiece and/or voice activated control. A coupling is provided, such as through an endo-probe, which is coupled to the one or more light sources. A user input device can be included that is operable to transmit to a feedback controller a first signal based on a user-selected light intensity. The feedback controller can, in response to the first signal, transmit a second signal to the power source for altering the power provided by the power source to the illumination system.

WO 2008/106590 A2

PORTABLE HANDHELD ILLUMINATION SYSTEM

RELATED APPLICATION

[0001] This application claims the benefit of U.S. Provisional Patent Application No. 60/892,028 filed 28 February 2007, the entire contents of which are incorporated herein by reference.

BACKGROUND

[0002] Prior art surgical lighting techniques, including applications of light sources in ophthalmology surgery, have utilized tungsten halogen, metal halide, xenon arc, etc. Such surgical lighting techniques can present a number of limitations. For example, halogen bulbs suffer from relatively low efficiency, poor reliability, considerable generation of heat, and a relatively short lifetime.

[0003] Moreover, because of packaging limitations, the light for such prior art lighting has typically required use of fiber optics for delivery from the peripheral illumination source to the inside of the eye, considerable resultant light loss. Such packaging limitations have also contributed to bulky, expensive, and inconvenient lighting, that has often exhibited poor robustness, e.g., has been susceptible to system vibrations, dirt, and moisture.

[0004] What is desirable, therefore, are surgical lighting techniques that address the noted limitations of prior art surgical lighting techniques. What is further desirable are surgical lighting techniques that can be utilized for surgeries on the eye and related physical structures.

SUMMARY

[0005] Embodiments and aspects of the present disclosure address limitations of the prior art by utilizing configurations of light sources in conjunction with a corresponding power supply, a handheld device, and fiber optics for delivery of light at desired wavelengths to a surgical site. Light Emitting Diodes (also known as "LED"s) can be

used as light sources in exemplary embodiments. Embodiments of an illumination system according to the present disclosure can further include one or more lenses and/or filters for selecting one or more specific wavelengths or wavelength ranges from the optical output of the light source(s).

[0006] An aspect of the present disclosure is directed to an illumination system including a handheld, untethered, portable, and complete surgical intraocular illumination system utilizing one or more LEDs as light sources. Such systems can accordingly be disposable, low-cost, and energy efficient. By use of such systems, a surgeon can have direct control of turning the illuminator on and off and adjusting the intensity by way of a simple control ergonomically placed on the handpiece and/or voice activated control. The handheld system can be incorporated in an injection molded housing structure. An energy supply component/system, e.g., a battery, can be included to provide power to the illumination system. The system can include an electronic system that includes a microprocessor and related circuitry that generates current pulses for the LEDs. In addition, the circuitry can consist of a converter, e.g., a boost converter, to power the LEDs. A coupling can be provided through a probe, e.g., an endo-probe, which can be coupled to the LED(s).

[0007] According to an embodiment of the present disclosure, an illumination system can include a host system and a portable handpiece communicating with the host system over a wired communication protocol. The host system can include a power source and a feedback controller. The portable handpiece can include an illumination system that emits light responsive to power received from the power source. The illumination system is preferably implemented via light emitting diodes (LEDs). The portable handpiece can also include a user input device for controlling intensity of light emitted by the illumination system. The user input device can transmit to the feedback controller a first signal based on a user-selected light intensity. The feedback controller can transmit in response to the first signal, a second signal to the power source for altering the power provided by the power source to the illumination system.

[0008] According to a further embodiment of the present disclosure, an illumination system can include a host system and a portable handpiece communicating with the host system over a wireless communication protocol. According to this embodiment, the host system can include a first transceiver adhering to a wireless communication protocol and a voice recognition system. The portable handpiece can include a second transceiver for wireless communication with the host system, a power source, a feedback controller, and an illumination system emitting light responsive to power received from the power source. A first user input device can control intensity of the light emitted by the illumination system. The first user input device transmits to the feedback controller a first signal based on a user-selected light intensity. The feedback controller transmits in response to the first signal, a second signal to the power source for altering the power provided by the power source to the illumination system. The handpiece can also include a second user input device for receiving voice data provided by the user. The voice data is wirelessly transmitted by the second transceiver to the first transceiver and processed by the voice recognition system for storing or generating an output in response.

[0009] According to further embodiments, the handheld illumination device may serve as potential light source for other illuminated instruments beside vitrectomy intraocular illumination, such as, for example, indirect ophthalmoscope, direct ophthalmoscope, slit lamp, and fundus camera, etc.

[00010] Other aspects, embodiments, and details of the of present disclosure will be apparent from the following description when read together with the accompanying drawings.

BRIEF DESCRIPTION OF FIGURES

[00011] Aspects of the present disclosure may be more fully understood from the following description when read together with the accompanying drawings, which are to be regarded as illustrative in nature, and not as limiting. The drawings are not

necessarily to scale, emphasis instead being placed on the principles of the disclosure.

In the drawings:

[00012] FIG. 1 is a schematic view of a system level representation of a portion of a handheld illumination system according to an embodiment of the present disclosure;

[00013] FIG. 2 is a schematic view of a light emitting diode;

[00014] FIG. 3 depicts a system level representation of a wired illumination system according to an embodiment of the present disclosure, in which the host equipment and the handheld illumination system are configured to communicate through a wired protocol;

[00015] FIG. 4 depicts a system level representation of a wireless illumination system according to an embodiment of the present disclosure, in which the host and the handheld illumination system also are configured to communicate through a wireless protocol;

[00016] FIG. 5 depicts a block diagram representation of a wired illumination system according to one embodiment of the disclosure;

[00017] FIG. 6 depicts a block diagram representation of a wireless illumination system according to one embodiment of the disclosure;

[00018] FIG. 7 depicts configurations of LEDs utilized as optical sources, with red, blue, green and white colors indicated; and

[00019] FIG. 8 depicts a diagrammatic view of application features an exemplary embodiment of feedback control for LED selectivity, according to the present disclosure.

[00020] It should be understood by one skilled in the art that the embodiments depicted in the drawings are illustrative and variations of those shown as well as other embodiments described herein may be envisioned and practiced within the scope of the disclosure.

DETAILED DESCRIPTION

[00021] Aspects and embodiments of the present disclosure are directed to and can provide illumination systems, and related techniques/methods, utilizing a handheld surgical, e.g., intraocular, illumination system with one or more light sources. Such handheld illumination systems can be portable and/or include portable components. Exemplary embodiments according to the present disclosure provide light sources including one or more light emitting diodes (also known as LED's).

[00022] Such handheld systems may be used as or included with an endo-probe, useful for surgical procedures including those performed on the eye. Such systems can include feedback functionality allowing a surgeon/operator to adjust light output, and may be disposable, low-cost, and energy efficient. By use of such systems, a surgeon can have direct control of turning an illuminator of the system on and off and adjusting the light intensity by way of a simple control ergonomically placed on the handpiece and/or voice activated control.

[00023] LED light sources used in/for embodiments of the present disclosure can provide various advantages. As they are based on electronic component design, LEDs are largely if not entirely immune from or resistant to system vibrations. LEDs can be protected from dirt and moisture, facilitating useful lifetimes that can increase to or approach thousands of hours, which is much higher than a non-LED light source. Further, LED-based light sources can operate at lower temperatures, and therefore have lower heat dissipation requirement, thereby eliminating complex heat sink systems commonly used for prior art lighting techniques. Cost of a single LED system is exponentially less expensive than a stand light source system because of the simple packaging. Additionally, LEDs are available in multiple colors/including high output efficiency.

[00024] LED-based systems according to the present disclosure can offer improved surgeon controlled surgical instruments that can provide lighting that is either automatically or manually controlled. Such lighting can also offer improved contrast ratio by wavelength selection. An input signal can be pulsed so as to allow spectral

selectivity in an LED; chandelier lighting can be provided. Further, techniques/systems according to the present disclosure can allow the use of reflectance spectroscopy inside the eye. Improved light control may be provided during the air/fluid interface during surgical procedures, e.g., by utilizing a capacitance switch; one or more coatings (e.g., electrical contact) of the top of a cannula used for surgery; a pressure sensor; and/or temperature sensor based feedback.

[00025] Disposable systems according to the present disclosure can allow for (e.g., potentially unlimited) redundancy. For example, if one unit fails can open up another. Simple and smaller packaging allows the main vitrectomy control unit to be free of supporting a light source. This can allow flexibility in the design of future vitrectomy control units. Potentially allow clinic based surgery (surgery outside of the conventional operating room).

[00026] Handheld systems according to the present disclosure can include four primary components, as is described in greater detail below, including specifically selected/configured light sources. In addition to lights sources, various individual components/features useful for exemplary embodiments of the present disclosure can include a coupling system that can include one or more lens and filter configurations, and can allow a physician to select the wavelength of the light. Embodiments can also employ a fiber/coupling interface. The fiber/coupling interface can be configured so that the selected light is collimated/converged using a coupling system and then transmitted to (interfaced with) one or more optical fibers for improved coupling efficiency. A fiber output state/stage can also be used and can include one or more (possibly specialty) fibers for selective outputs. The fiber(s) can also be used as filters by using thin film deposited fibers.

[00027] FIG. 1 is a schematic view of a system level representation of a handheld illumination system 100 according to an embodiment of the present disclosure. System 100 can include a light source system, e.g., a LED source system 102, that can include a configuration of one or more light sources. The source system 102 can be connected to a coupling system 104 which can be connected to a fiber/coupling interface 106. The

fiber/coupling interface 106 can be configured and arranged to provide light to a fiber output stage 108, as shown in the drawing.

[00028] Four primary components of the handheld system 100 can be incorporated in an injection molded housing structure, in exemplary embodiments. The energy supply component can be a DC source (e.g., a battery or rectified AC source) or a AC source and powers an electronic system. The electronic system, in turn, can consist of the microprocessor circuitry, which can be operational to provide a signal (e.g., current pulse) to the next component in the optical system, e.g., one or more light sources such as LEDs. In addition, the circuitry can include a converter/regulator, e.g., a boost converter. For battery-powered embodiments, a converter can be operable to step up the battery voltage to that required for light source(s), e.g., one or more LED sources.

[00029] The light source(s), e.g., one or more LEDs 102, can be run or operated on a suitable power supply, e.g., a current drive related to the discharge current of the battery. This allows a light source, e.g., and LED, to operate on an AC drive (e.g., from a wall plug) at a fixed/varied frequency. The coupling can be provided through the endo-probe component. As the system runs on pulse signal (e.g., a rectified AC signal) the power dissipated by the LED is a fraction of the steady state condition, allowing the temperature rise in the handle to be minimal. The parameters of the pulse signal (example: duty cycle etc.) can be changed in the design to achieve lower temperature dissipation. The intensity can be variable, which can allow a surgeon to control the optical output characteristics, e.g., during surgical procedures.

[00030] Continuing with the description of FIG. 1, suitable driver/driving parameters may be implemented for the power supplied to the light source(s) 102 of the handheld device. For example, a pulse rate can be implemented/designed that meets the minimum threshold for flicker fusion (human perception of a pulsed light as continuous), e.g., at greater than 60Hz and less than 150 Hz, in exemplary embodiments. Any suitable duty cycle can be utilized. For example, a duty cycle can be used that varies from 1 % to 90% for a pulsed scenario. Suitable current is used,

depending on the type and configuration of light sources utilized, e.g., current can be used over a range that varies from 10 mA – 1500 mA.

[00031] FIG. 2 is a schematic of a light emitting diode 200, or LED, useful for use as a light source in exemplary embodiments of the present disclosure. As is known, LEDs are devices that convert electrical energy into optical energy. LED 200 is a semiconductor based diode (device) including a p-doped region 202 and a n-doped region 204. The principle behind an LED is as an electron in the conduction band recombines with a hole in the valence band; the electron makes a transition to a lower-lying energy state. This leads to the release of energy in an amount equal to the band-gap energy. In general, the energy is dissipated by phonons (heat) or photons (light). In an LED, this energy goes into emitted light energy.

[00032] When LED 200 is stimulated electrically as by a current (depicted by arrows) produced in response to an applied voltage 206, electrons and hole carriers in the p-n junction (depicted by elliptical region with opposed arrows) recombine, emitting photons as an incoherent narrow spectrum of light 208. This phenomenon is termed electroluminescence, where the color (UV, Visible, IR) of light depends on the type of the semiconductor material(s) used for the p-doped region 202 and n-doped region. Typically, the voltage applied to a LED is about 2.5V to about 4.0V, depending on the material(s) present.

[00033] As shown in FIG. 2, the LED emits optical power in proportion to the forward current through the diode interface. In addition, as LED 200 is a low voltage device, it has a longer life than traditional sources. The frequency response of LED's are ~10 MHz and the light can be collimated with a lens system (not shown). For exemplary embodiments, the voltage drop across LEDs utilized can be less than the specified forward voltage (for the particular LEDs), and the temperature of the handheld can be less than 40°C. The current source into the LED can be less than the specified current limit for each of the LEDs and the temperature of the handheld can be less than 40°C. Power can be supplied with a battery/battery pack contained within the hand piece, in exemplary embodiments.

[00034] According to exemplary embodiments of the preset disclosure, a novel optical handheld ophthalmic surgical instrument design for high efficiency illumination may be implemented as a wired illumination system or a wireless illumination system.

[00035] FIG. 3 shows a system level representation of a wired illumination system 300, where the host equipment/system 302 and the handheld illumination system 304 communicate through a wired protocol according to one embodiment of the disclosure. The host system 302 can include a command/control component, and can include current/voltage drivers with a computational platform. Additionally, the handheld system is an optical platform with an internal light source and coupling system.

[00036] FIG. 4 shows a system level representation of a wireless illumination system, in accordance with exemplary embodiments of the present disclosure. In system 400, a host system 402 can communicate with a handheld illumination system 404. According to an embodiment, the host system consists of the command/control only. The handheld system can be both an electrical and optical platform with an internal light source and coupling system. FIGS. 5 and 6 show details of the systems of FIGS. 3 and 4, respectively, in greater detail.

[00037] FIG. 5 is a block representation of a wired illumination system 500 according to an embodiment of the present disclosure. As shown in FIG. 5, the wired illumination 500 can include a host system 502 and a handheld illumination system 503.

[00038] The host system 502 can include a power supply, e.g., current/voltage source 506, that is operable to maintain and/or supply a required power to the handheld device, e.g., endoscope. Host system 502 can include a feedback control system 508. In FIG. 5, the arrows in the block diagram indicate the signal directionality. The power source 506 in the host system 502 supplies variable signal to the light source(s), e.g., embedded in the handheld system 503. Feedback control system 508 can be operable to communicate with the handheld system 503 either through a wired mechanism, as indicated in FIG. 5, or through a wireless connection, e.g., as indicated in FIG. 6.

Handheld system 503 can also include a surrounding base or (docking) station 504, which can include components/systems such as cooling system 518, operational to cool the LED source system 510 or other portions of system 503 to a desired temperature, e.g., below 40 C, and/or feedback button 520.

[00039] The handheld illumination system 503 can include one or more light sources 510, which are preferably (though not necessarily) LEDs. Handheld illumination system 593 can include a coupling system 512. Fiber coupling system 512 can include suitable or desired lens and/or filter configurations and can allow a system operator (e.g., a physician) to select the wavelength of the light produced.

[00040] Handheld system 503 can further include a fiber/coupling interface 514. The fiber/coupling interface 514 can connect the coupling system 512 to the fiber output stage 516 and can be configured and arranged such that the selected light is collimated/converged using, e.g., an optical coupling system/assembly, and then interfaced with an optical fiber for improved coupling efficiency. A fiber output stage 516 can receive the light from the coupling system 512 and/or fiber/coupling interface 514 and can include one or more desired, e.g., specialty fibers, for selective outputs. The fiber(s) can also be used as filters by using thin film deposited fibers.

[00041] As shown, handheld system 503 can include a feedback triggering mechanism 520, e.g., button, switch, voice activated control, and the like. The feedback mechanism 520, e.g., button, can facilitate an operator's (e.g., a surgeon's) control of the light intensity at the output of the illuminated surgical instrument. For example, a surgeon could press button 520, in which event a signal would correspondingly be transmitted through a wire (wired connection indicated) to the feedback controller/control system 508. The feedback system 508 would then send a signal to the voltage/current source 506 leading so as to alter the power supplied to the light source(s), e.g., LED source system 510, to alter light output characteristic(s) such as intensity.

[00042] This feedback from the operator can allow or facilitate real time analysis and control and better viewing especially during an air fluid exchange during an operation. For further example, such feedback can be controlled such that the optical light intensity decreases/increases in and out of the eye chamber during a surgical procedure. A person of skill in the art should recognize that the input device used for the feedback may take any form known in the art, and is not limited to only buttons. For example, feedback may be in the form of voice commands.

[00043] The handheld portion, e.g., endo-scope, can be incorporated into and/or implemented with a mechanical design to reduce heat. In addition, a heat sink is used at the source end of the handheld system. According to the wired embodiment 500, the communication between the host 502 and the illumination system 503 is through a wired protocol.

[00044] FIG. 6 depicts a block diagram representation of a wireless illumination system 600 according to one embodiment of the present disclosure. As shown in FIG. 6, wireless illumination 600 can include a host system 602 and the handheld illumination system 603. The host system 602 can include a wireless protocol system 606 that includes of is linked with a trans-receiver (transceiver) system 608 to allow wireless communication with the handheld illumination system 603. Additionally, in exemplary embodiments, the host system 602 can include a voice activated protocol system 610. Protocol system 610 can include voice recognition software and hardware (e.g., voice recognition system), to permit a system operator (e.g., a surgeon) to communicate with the system 602/600. This allows voice commands in the application control of the system. The arrows in the block diagram indicate signal directionality.

[00045] The handheld illumination system 603 can include a power source 614 and feedback system 624 so that a handheld device, e.g., endo-probe, with the built-in lighting functionality can be self-powered and can communicate with feedback control/button 630. The handheld device 603 may further include a microphone for allowing entry of the voice commands by the surgeon. System 603 can include a power source (voltage/current source) 614, a light source system 616, e.g., a feedback control

system 624, and a transceiver 628. According to the wireless embodiment of FIG. 6, the communication between the host system 602 and the illumination system 603 is through a wireless protocol. Handheld system 603 can also include a surrounding base or (docking) station 604, which can include components/systems such as cooling system 626, operational to cool the LED source system 616 or other portions of system 603 to a desired temperature, e.g., below 40 C, and/or feedback button 630.

[00046] As shown in FIG. 6, host system 602 can include a first transceiver 608, e.g., one adhering to a wireless communication protocol, and a voice recognition system 610 that can implement a voice activated protocol. Portable handpiece or handheld illumination system 603 can include a second transceiver 628 (for wireless communication with the host system 602), a power source 614, a feedback controller 624, and an illumination system emitting light 616 responsive to power received from the power source 614.

[00047] For system 600, a first user input device, e.g., feedback button 630, can control intensity of the light emitted by the illumination system 616. The first user input device 630 is operable to transmit to the feedback controller 624 a first signal based on a user-selected light intensity. The feedback controller 624 can transmit, in response to the first signal, a second signal to the power source 614 for altering the power provided by the power source 614 to the illumination system 616. The handpiece can also include a second user input device, e.g., sound sensor or microphone 631, for receiving voice data provided by the user. The voice data can wirelessly transmitted by the second transceiver 628 to the first transceiver 608 and processed by the voice recognition system 610 for storing or generating an output in response.

[00048] The handheld system 603 can be incorporated in an injection molded housing structure. An energy supply component/system 614, e.g., a battery, can be included to provide power to the illumination system 616. The energy supply system 614 can include an electronic system that includes a microprocessor and related circuitry. The microprocessor/controller and related circuitry can or convert (e.g., rectify AC to pulsed DC) power to a desired condition, e.g., to regulate current pulses

for the LEDs. In addition, the circuitry can consist of a converter, e.g., a boost, Buck, step down, step up, etc., to condition the power for the LEDs. A coupling can be provided through a probe, e.g., an endo-probe, which can be coupled to the LED(s).

[00049] According to exemplary embodiments, the handheld illumination device may serve as potential light source for other illuminated instruments beside vitrectomy intraocular illumination, such as, for example, indirect ophthalmoscope, direct ophthalmoscope, slit lamp, and fundus camera.

[00050] Referring now to FIG. 7, light source configurations 700A-700C are depicted that utilize LEDs, with red, blue, green and white light outputs, in accordance with exemplary embodiments of the present disclosure. For configuration 700A-700C, base 702 can provide support for the LEDs 704, as shown. Base 702 can be made of any suitable material, e.g., plastic, metal, etc.

[00051] LEDs 704 that are selected (e.g., based on a user control command) as light sources can provide an optical signal/output for illumination in a band of specific wavelengths. The different sources (red, green, blue, white, etc.) can be configured in a designated patterns for maximum light output efficiency. One of the advantages using this configuration is that by controlling the current to the LED, the output light can be tuned at various intensities. This can allow for better safety/visualization and illumination that is tunable to individual cases and surgeons. In addition, the variation in light of different spectrum of the outputs of the LEDs 704 can allow for improved contrast ratios for surgical illumination.

[00052] In exemplary embodiments, e.g., those shown for FIG. 7, an illumination system according to the present disclosure can use multiple LED sources so as to provide an increased flux strength for illumination. Such multiple LEDs (or other sources) can be arranged in desired configurations, such as a star, hex, line, chandelier, etc. As for wavelengths of the optical output from the source(s), e.g., LEDs 704, the entire visible spectrum is usable. For LED sources, the optical intensities are easily tunable with the input current.

[00053] FIG. 8 depicts a diagrammatic view representing the application feature of feedback control for LED selectivity according to an exemplary embodiment 800 of the present disclosure. As FIG. 8 shows, specific commands 802 control a control block 804 (e.g., feedback control) to activate one or more specific LEDs 806(1)-806(N) or a particular sub-combination of such LEDs 806(1)-806(N). The activation of specific LEDs and utilization of the light from the LED(s), can involve a combination of optical and electronic designs, e.g., as shown and described for FIGS. 1-7, and may be implemented either in a handheld or in the host system according to particular embodiments. The physicians command can be a feedback button/mechanism, e.g., as shown and described for FIGS. 5-6. In addition, feedback can allow the incorporation of a mechanism to determine/select one or more optical characteristics, e.g., how long an optical signal is ON (overall time and/or duty cycle), a particular wavelength or range used, and intensity.

[00054] Continuing with the description of FIG. 8, light produced by the LED(s) can be coupled, e.g., using a coupling system 810, into one or more optical fibers 812. This coupling system 810 can include a combination of one or more lenses 814 and/or one or more filters, which can serve to increase coupling efficiency of light output from the LED(s) 806(N) to the fiber(s) 812. In exemplary embodiments, fiber 812 can be placed through a casing (e.g., steel) to direct the light in a specific direction, e.g., to a desired portion of an endoscope. In exemplary embodiments, one or more specialized fibers can be used for specific filtering purposes and/or for desired applications. One skilled in the art, should appreciate that any suitable materials and/or shapes can be utilized for a lens 814 of coupling system 810. Further, one skilled in the art should appreciate that any suitable configuration (e.g., thin film, Fabry-Perot, etc.) and/or material can be used for a filter 816 of the coupling system 810. One or more lens 818 may be present at the tip of fiber 812 and may provide optional magnification, collimation, or focusing at the tip of the fiber 812.

[00055] Thus, from the previous description and review of the related drawings, it will be understood that embodiments and aspects of the present disclosure can provide various advantages relative to prior art techniques/systems.

[00056] The output light distribution of light sources utilized for embodiments of the present disclosure can be selected or designed for as desired. For example, an optical output can be Lambertian, "bat winged", Gaussian, etc. and suitable lenses and/or optical elements can be used with/for the light sources to give the desired output light distribution pattern. Further, a cooling system can be used to provide a cooling effect, allowing the illumination system to operate at low temperature(s), e.g., room temperature. Portability: light weight and small in size with no specialized cooling systems necessarily required for the handheld device (cooling may be implemented with the optical source system/components).

[00057] Feedback functionality can provide handheld control for physicians, and such ability may be provided by a convenient feedback button such as located on a handpiece/handheld device, probe, docking station for the handheld device, etc. Control of power current/voltage can be incorporated into the feedback control. Variable gain amplifiers can be incorporated in the power source, for exemplary embodiments, e.g., to provide dimming functionality. An automatic light in/out of the cannula feature may be implemented using the feedback button. A lens system utilized can be small and portable. Collimation and convergence as well as a variable spot size are also features that can be adjusted, e.g., by a surgeon operating a feedback controller/button.

[00058] Further advantages provided by embodiments of the present disclosure, can include the utilization of one or more combination of filters/attenuators. Also, optical fibers including special fibers with thin films deposited to eliminate harmful spectrum can be utilized. Different fiber configurations can be utilized, e.g., tapered, round, adiabatic, single-mode, multimode, graded index (GRIN), etc. Fiber optics used for embodiments may be selected and sized as desired, e.g., 50 μ m-500 μ m, and may be of multimode or single mode options/designs.

[00059] By utilizing LEDs as light sources, systems/techniques of the present disclosure can provide lighting that is largely if not entirely immune from or resistant to system vibrations. Lighting component lifetime can increase to thousands of hours, which is much higher than a normal (non-LED) light source. Further, LED-based light sources according to embodiments of the present disclosure can operate at lower temperatures, and therefore dissipate low heat, thereby eliminating complex heat sink systems. Costs related to lighting of the present disclosure techniques can be lower than that of prior art techniques, as costs for LED systems (including related driving power regulation circuitry) can be much less (e.g., exponentially less) expensive than a stand light source system because of the simple packaging. Additionally, LEDs are available in multiple colors/including high output efficiency, leading to selection of visible (and other) spectrums during surgical procedures, including those performed on the structure of the eye.

[00060] Moreover, LED-based lighting systems according to the present disclosure can offer improved surgeon controlled surgical instruments that can provide lighting that is either automatically or manually controlled. Such lighting can also offer improved contrast ratio by wavelength selection. An input signal can be pulsed so as to allow spectral selectivity in an LED; chandelier lighting can be provided. Further, techniques/systems according to the present disclosure can allow the use of reflectance spectroscopy inside the eye. Improved light control may be provided during the air/fluid interface during surgical procedures.

[00061] Further, embodiments of the present disclosure can allow handheld illumination device to allow novel application outside of the operating room and independent of an integrated vitrectomy control unit or an expensive light source box, e.g., use in a clinic; and/or potential light source for other illuminated instruments beside vitrectomy intraocular illumination, such as for an indirect ophthalmoscope, a direct ophthalmoscope, a slit lamp, a fundus camera, and the like.

[00062] Although the present disclosure has been described in certain specific embodiments, those skilled in the art will have no difficulty devising variations to the

described embodiment which in no way depart from the scope and spirit of the present disclosure. For example, although the illumination system according to the previously described embodiments have generally been in the context of utilizing LEDs, a person of skill in the art should recognize that other types of light sources may also be used in addition or in lieu of LEDs. Furthermore, in addition or in lieu of manual adjustment of the light intensity via the feedback buttons, sensors may also be incorporated into the handpiece for sensing different types of lighting requirements for automatically adjusting the light intensity based on the sensed lighting requirements.

[00063] Furthermore, to those skilled in the various arts, the disclosure itself herein will suggest solutions to other tasks and adaptations for other applications. It is the Applicants' intention to cover all such uses of the disclosure and those changes and modifications which could be made to the embodiments of the disclosure herein chosen for the purpose of disclosure without departing from the spirit and scope of the disclosure. Thus, the present embodiments of the disclosure should be considered in all respects as illustrative and not restrictive.

CLAIMS

What is claimed is:

1. An illumination system comprising:

a power source configured and arranged to produce a power output of a desired power;

a portable handpiece including:

to an illumination system configured and arranged to emit light in response to power received from the power source;

of a coupling system configured and arranged to select a wavelength range of the light from the illumination system;

a coupling interface configured and arranged to couple light from the coupling system into one or more optical fibers; and

and a fiber output stage including one or more optical fibers and configured and arranged to deliver light from the coupling interface to a surgical site.

2. The system of claim 1, further comprising:

a feedback controller configured and arranged to adjust the power output of the power source; and

a user input device for controlling intensity of light emitted by the illumination system, the user input device transmitting to the feedback controller a first signal based on a user-selected light intensity, the feedback controller transmitting in response to the first signal, a second signal to the power source for altering the power provided by the power source to the illumination system.

3. The system of claim 2, wherein the feedback controller comprises a wired communication link with the user input device to provide feedback to the power supply.

4. The system of claim 2, wherein the handpiece comprises a transceiver and the feedback controller is configured and arranged to communication with a voice recognition system of a host system with a wireless communication link.
5. The system of claim 1, wherein the illumination system comprises one or more LEDs.
6. The system of claim 4, wherein the wireless control comprises an individual control located in the handpiece configured and arranged to control the intensity of the illumination system.
7. The system of claim 4, wherein the power source is disposed in the handpiece.
8. The system of claim 4, further comprising a sound sensor disposed within the handpiece and configured and arranged to detect spoken signals, wherein the sound sensor is configured and arranged to send an input signal to the feedback control system.
9. The system of claim 4, wherein the host system comprises a transceiver operational with a wireless protocol and a voice recognition system operational with a voice recognition protocol.
10. The system of claim 5, wherein the one or more LEDs comprise one or more LEDs operable to produce a green light output.
11. The system of claim 5, wherein the one or more LEDs comprise one or more LEDs operable to produce a blue light output.
12. The system of claim 5, wherein the one or more LEDs comprise one or more LEDs operable to produce a red light output.
13. The system of claim 5, wherein the one or more LEDs comprise one or more LEDs operable to produce a white light output.

14. The system of claim 4, wherein the plurality of light sources comprises a first light source operable at a first bandwidth of limited wavelength light and a second light source of visible wavelengths providing color tinted light.

15. A wired illumination system comprising:

an illumination system comprising a host system with a power source and controller with wired communication to a portable handheld illuminator with a control mechanism which communicates with the host system; and

a handheld illuminator emitting light responsive to power received from the host system.

16. The system of claim 15, wherein the handheld illuminator includes an input device for controlling the source power on/off state of the emitted light and intensity of the emitted light of the handheld illuminator.

17. The system of claim 16, wherein the input device comprises a user input device configured and arranged to transmit to the host system controller a first signal to turn on/off based on user selected power state, and wherein the host system controller is configured and arranged to transmit a second signal to the power source to initiate/terminate power to the light source.

18. The system of claim 17, wherein the user input device is configured and arranged to transmit a third signal to the host system controller to change the intensity of the broad bandwidth emitted light, and the controller is configured and arranged to transmit a fourth signal to the power source to alter the power the handheld illuminator.

19. The system of claim 18, wherein the he user input device is configured and arranged to transmit a fifth signal to the host system controller to control first intensity and spectral range.

20. An illumination system comprising:

a host system including:

a first transceiver adhering to a wireless communication protocol;

a voice recognition system; and

a portable handpiece communicating with the host system via the wireless communication protocol, the portable handpiece including:

a second transceiver for wireless communication with the host system;

a power source;

a feedback controller;

an illumination system emitting light responsive to power received from the power source;

a first user input device for controlling intensity of light emitted by the illumination system, the first user input device transmitting to the feedback controller a first signal based on a user-selected light intensity, the feedback controller transmitting in response to the first signal, a second signal to the power source for altering the power provided by the power source to the illumination system; and

a second user input device for receiving user input voice data, wherein the voice data is wirelessly transmitted by the second transceiver to the first transceiver and processed by the voice recognition system for storing or generating an output in response.

21. The system of claim 20, wherein the power source comprises a battery.

22. The system of claim 21, wherein the power source comprises a boost converter, operational to step up the battery voltage to that required for an LED source.

23. The system of claim 20, wherein a coupling is provided through an endo-probe component.

24. The system of claim 20, wherein a pulse rate of the illumination system meets a threshold for human perception of a pulsed light as continuous.
25. The system of claim 24, wherein the pulse rate is greater than 60Hz.
26. The system of claim 20, wherein the pulse rate is less than 150 Hz.
27. The system of claim 20, wherein a duty cycle of the illumination system varies between about 1 % and about 90%.
28. The system of claim 20, further comprising a cooling system configured and arranged to cool the illumination system to below a desired temperature.
29. The system of claim 28, wherein the desired temperature is less than 40°C and the portion of the system is the handpiece.
30. The system of claim 20, wherein the illumination system comprises a plurality of LEDs.

HANDHELD ILLUMINATION SYSTEM

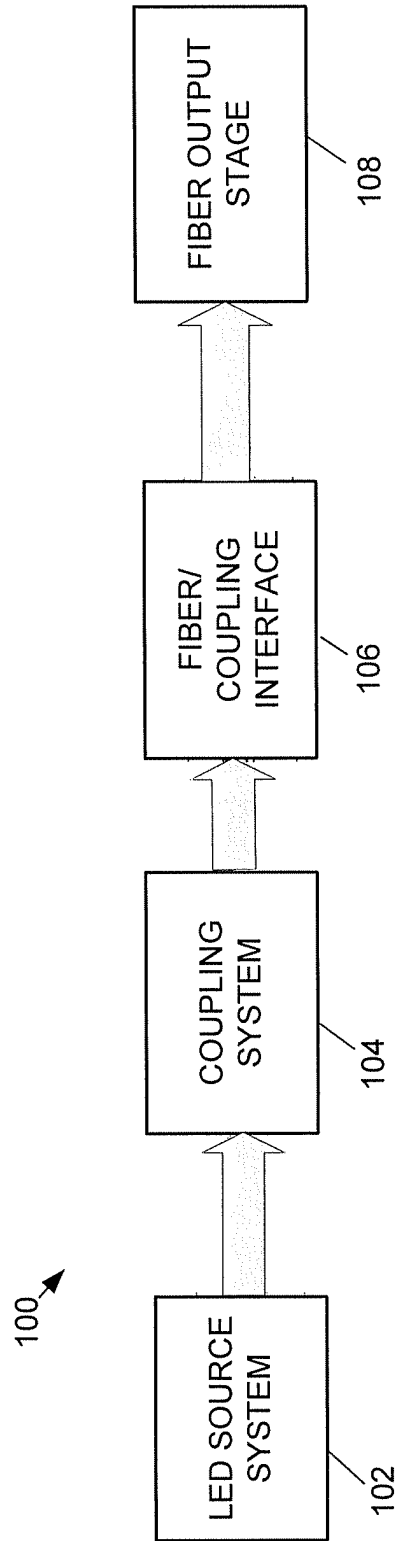
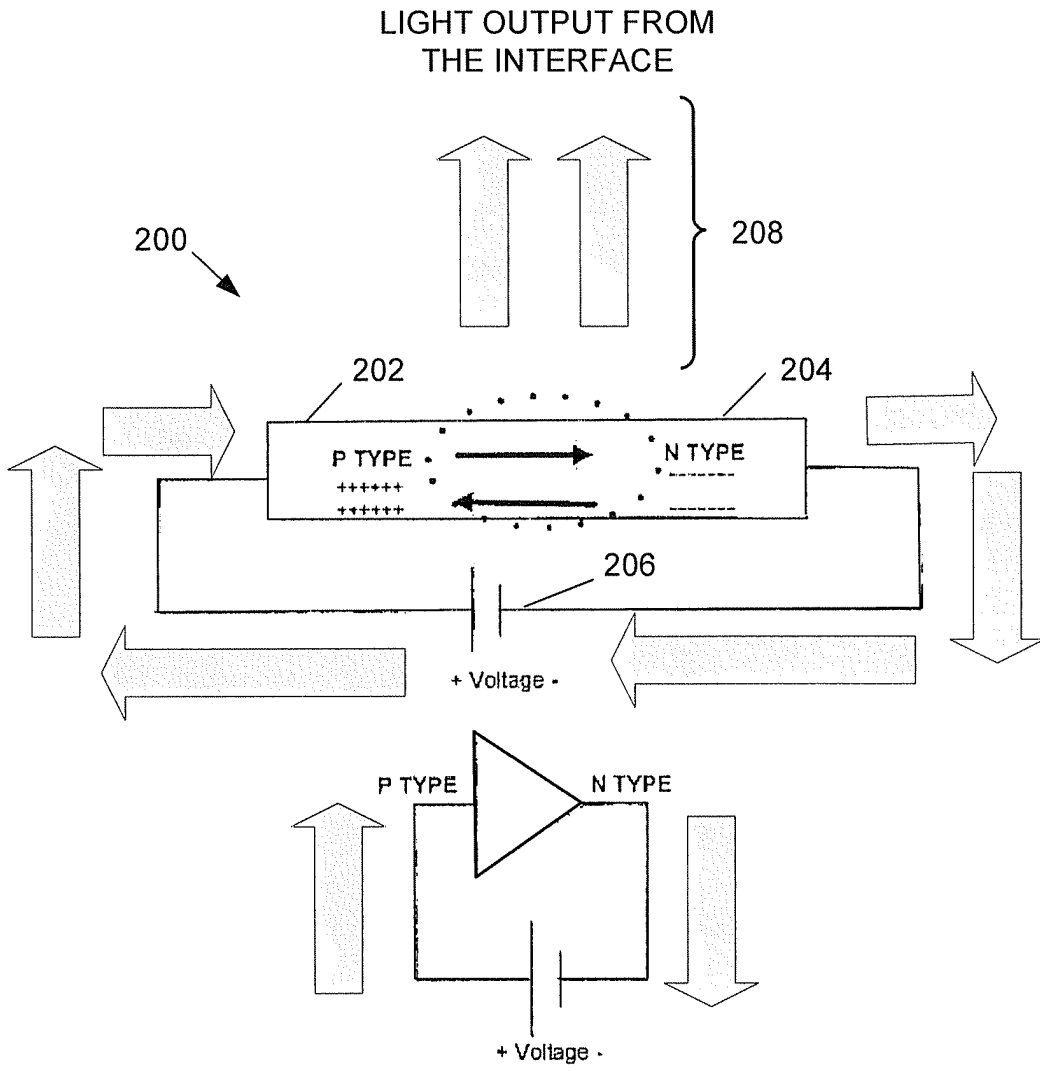

FIG. 1



SCHEMATIC OF A LIGHT
EMITTING DIODE

FIG. 2
(PRIOR ART)

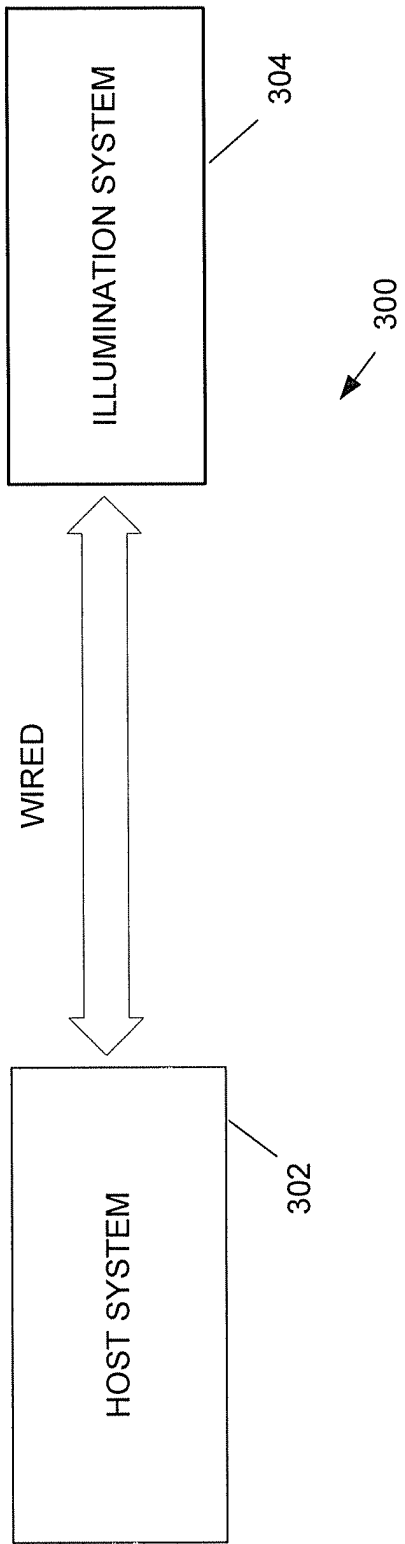

FIG. 3

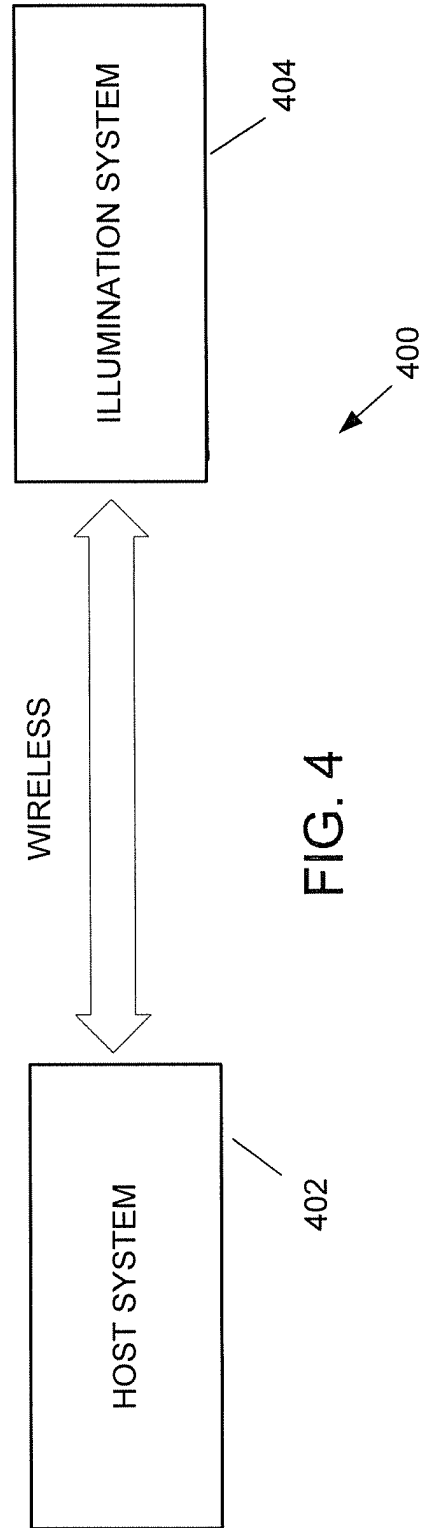
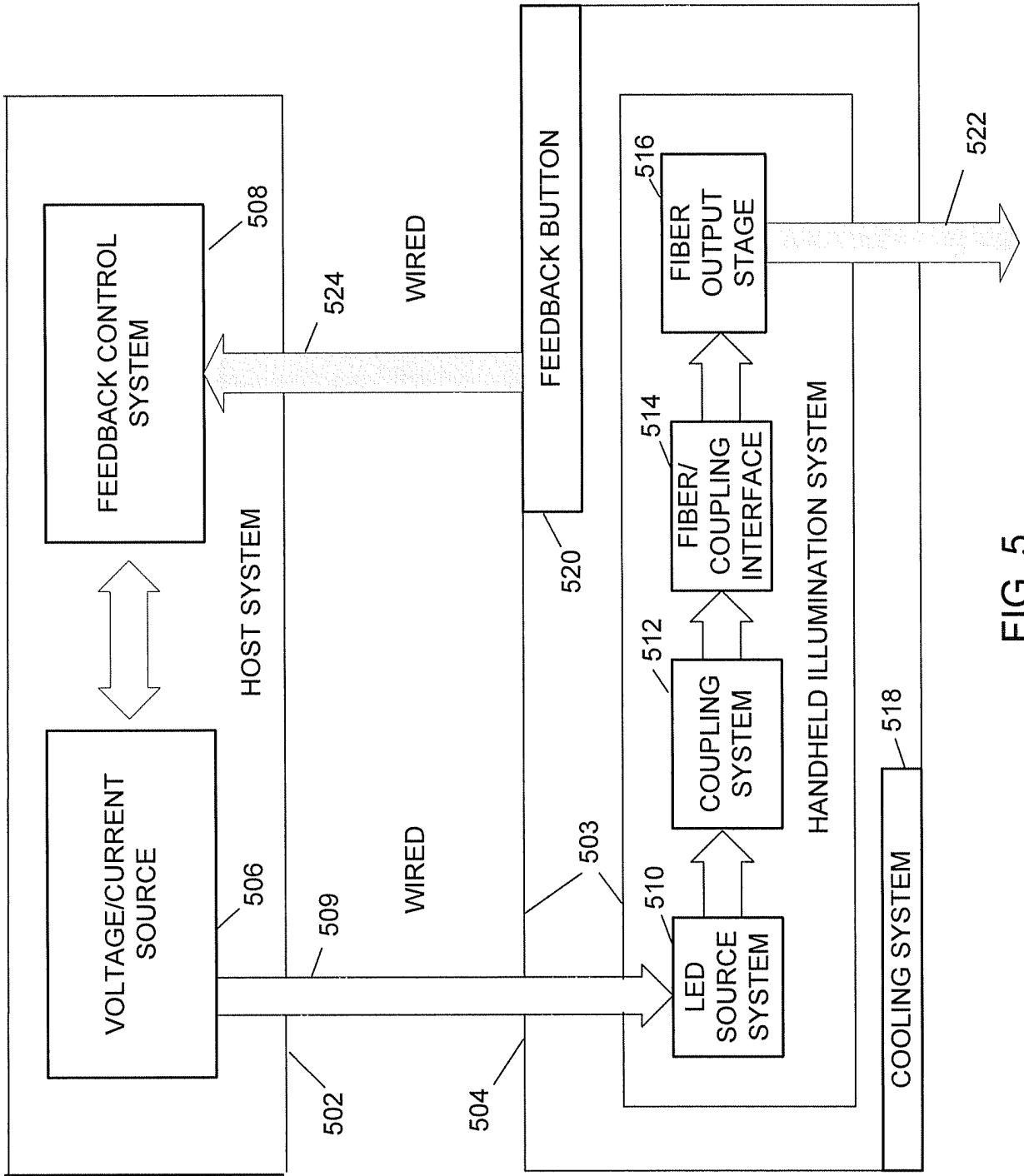

FIG. 4



500

FIG. 5

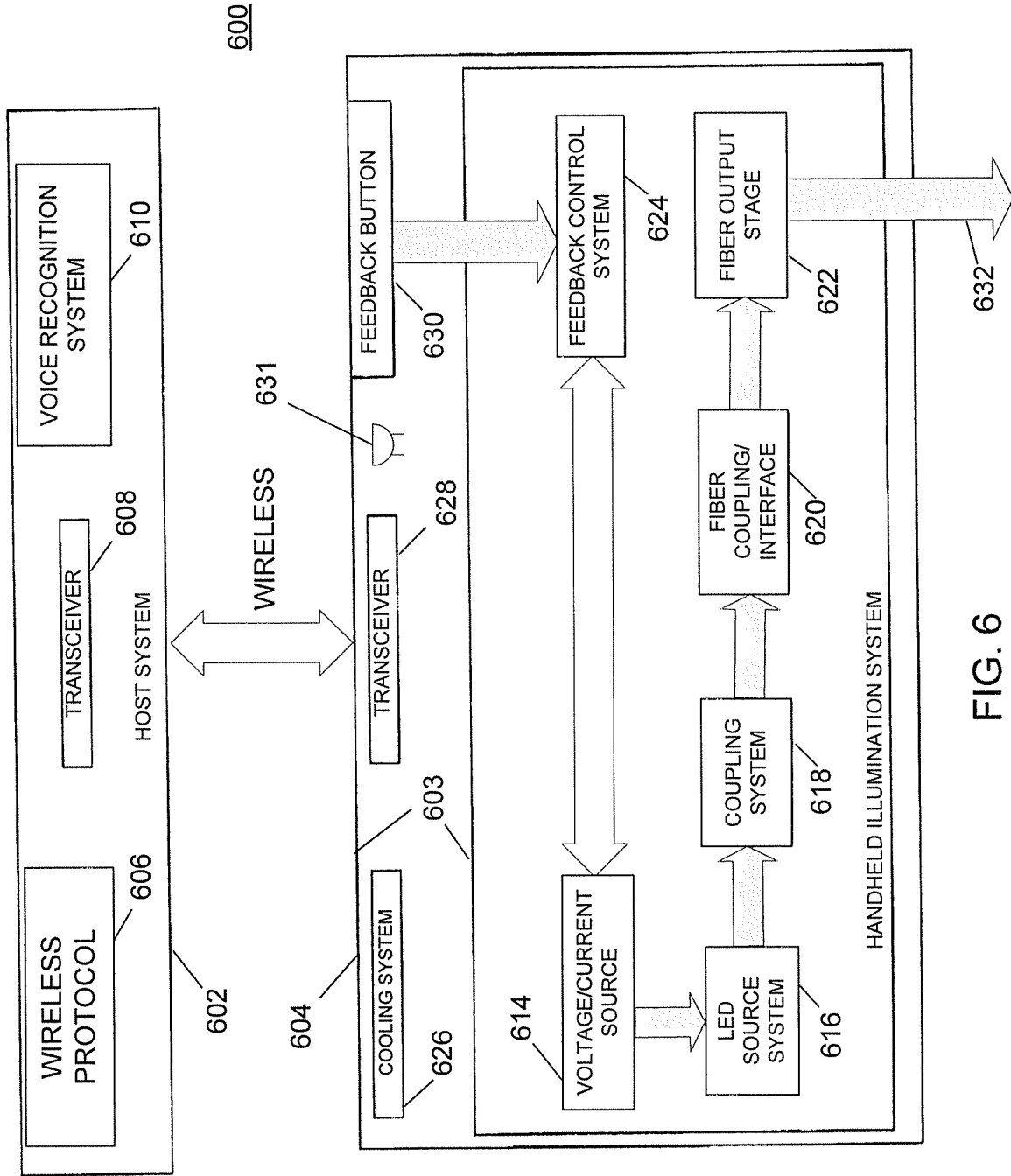

FIG. 6

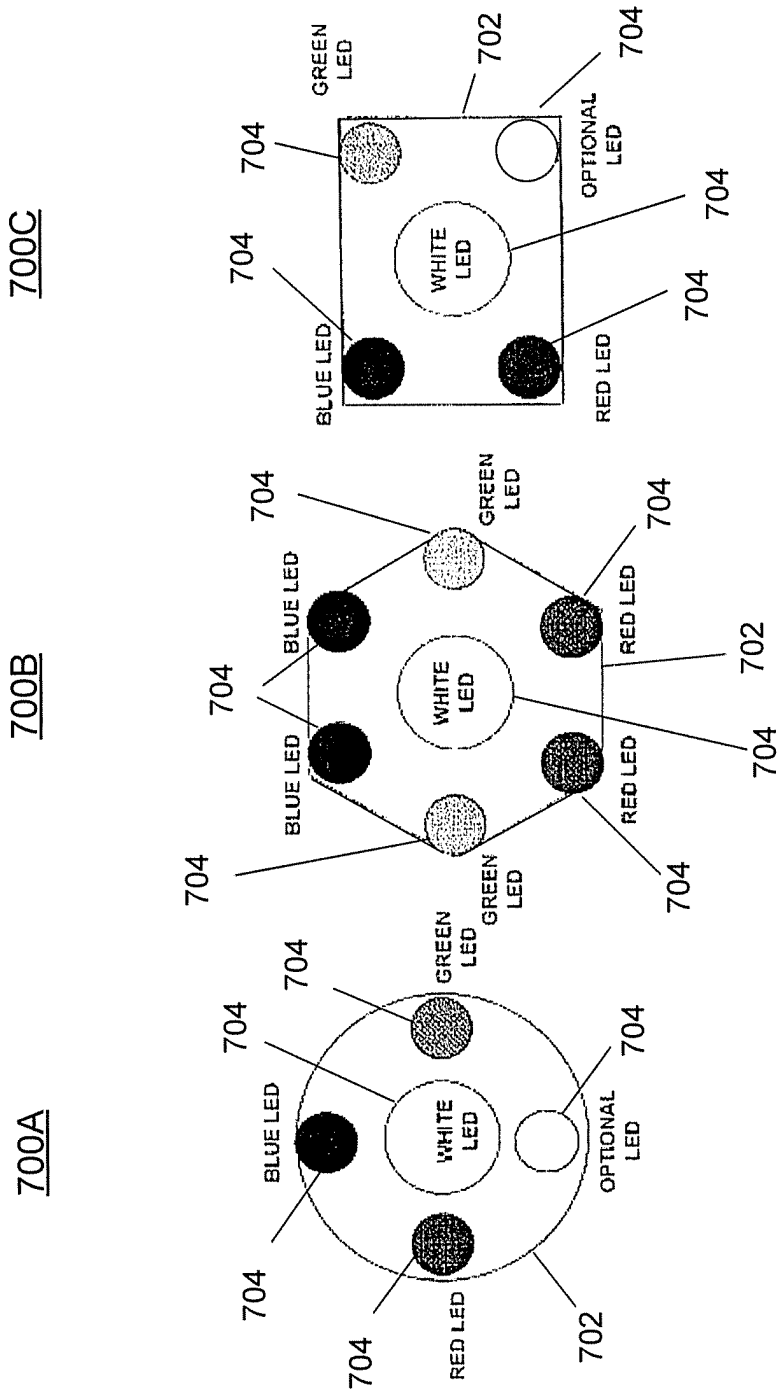
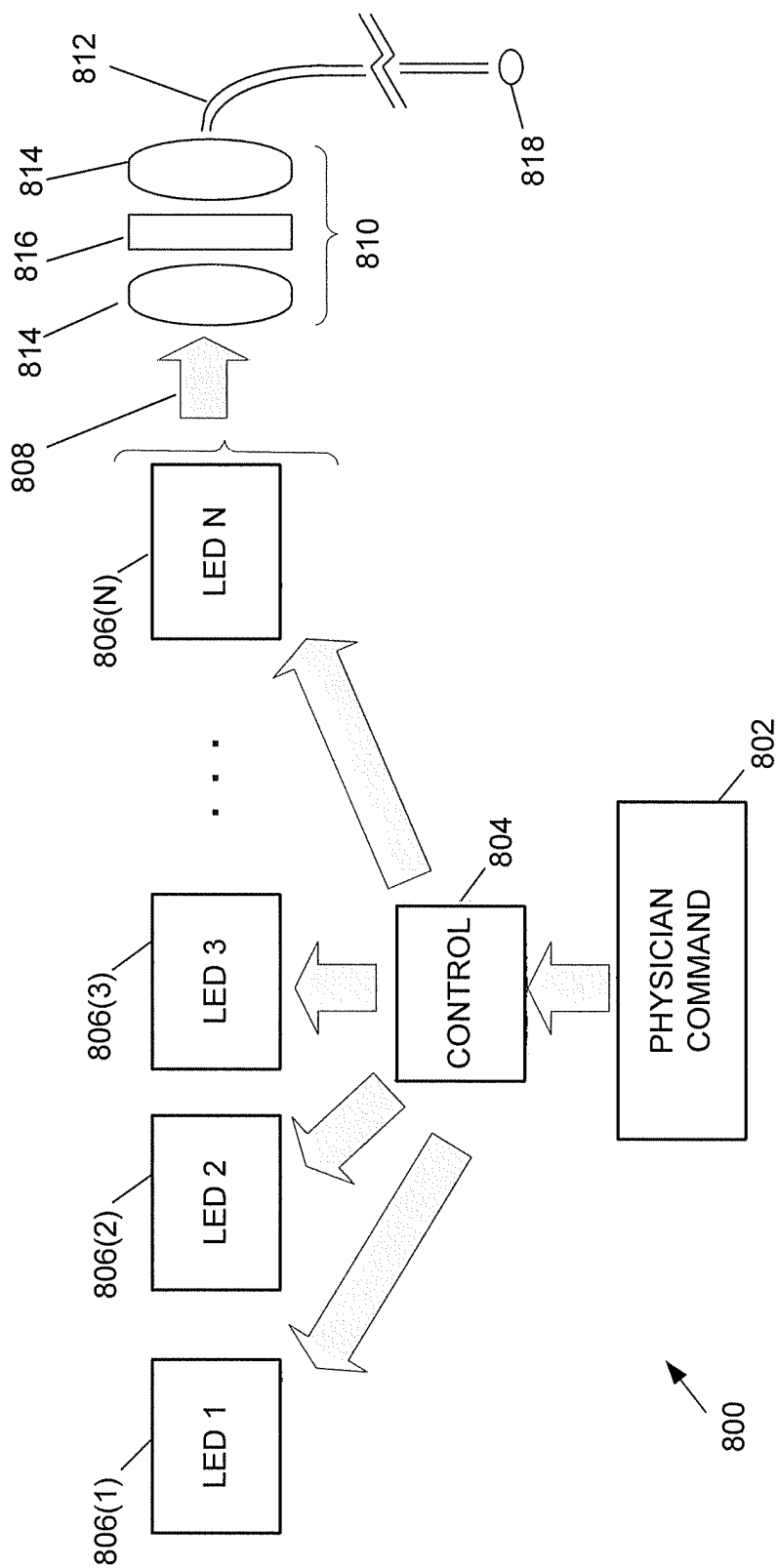

FIG. 7

FIG. 8



专利名称(译)	便携式手持照明系统		
公开(公告)号	EP2129964A2	公开(公告)日	2009-12-09
申请号	EP2008730952	申请日	2008-02-28
申请(专利权)人(译)	Doheny眼科学院		
当前申请(专利权)人(译)	Doheny眼科学院		
[标]发明人	BHADRI PRASHANT R DEBOER CHARLES MCCORMICK MATTHEW MAGALHAES OCTAVIANO LESCOULIE JAY BARNES AARON KERNS RALPH CHONG LAWRENCE HUMAYUN MARK LUE JAW CHYNG LORMEN		
发明人	BHADRI, PRASHANT, R. DEBOER, CHARLES MCCORMICK, MATTHEW MAGALHAES, OCTAVIANO LESCOULIE, JAY BARNES, AARON KERNS, RALPH CHONG, LAWRENCE HUMAYUN, MARK LUE, JAW-CHYNG, LORMEN		
IPC分类号	F21V21/40 A61B5/00 A61B19/00		
CPC分类号	A61B3/0008 A61B5/7475 A61B5/749 A61B90/36 A61B2017/00057 A61B2090/306 A61B2090/309 A61B2560/0214 A61B2560/0456 A61F9/007 H05B45/10 H05B47/12		
优先权	60/892028 2007-02-28 US		
其他公开文献	EP2129964A4		
外部链接	Espacenet		

摘要(译)

描述了可以包括一个或多个光源的照明系统，其可以包括LED，一个或多个透镜，以及一个或多个光纤。公开了一种手持式，便携式和手术式眼内照明系统，其是一次性的，低成本且高效的。外科医生可以直接控制打开和关闭照明器并通过符合人体工程学设置在手持件和/或语音激活控制器上的简单控制来调节强度。提供耦合，例如通过内探针，其耦合到一个或多个光源。可以包括用户输入设备，其可操作以基于用户选择的光强度向反馈控制器发送第一信号。响应于第一信号，反馈控制器可以将第二信号发送到电源，以改变由电源提供给照明系统的功率。

