

(19) World Intellectual Property Organization
International Bureau



(43) International Publication Date
5 December 2002 (05.12.2002)

PCT

(10) International Publication Number
WO 02/096286 A1

(51) International Patent Classification⁷: A61B 5/03, 5/00

(21) International Application Number: PCT/GB02/02546

(22) International Filing Date: 31 May 2002 (31.05.2002)

(25) Filing Language: English

(26) Publication Language: English

(30) Priority Data:
0113388.3 1 June 2001 (01.06.2001) GB

(71) Applicant (for all designated States except US): DI-AMETRICS MEDICAL LIMITED [GB/GB]; Short Street, High Wycombe, Bucks HP11 2QH (GB).

(72) Inventor; and

(75) Inventor/Applicant (for US only): BARNETT, Nick [GB/GB]; 60 Grays Road, Headington, Oxford OX3 7PY (GB).

(74) Agents: HUMPHREYS, Ceris, Anne et al.; Abel & Imray, 20 Red Lion Street, London WC1R 4PQ (GB).

(81) Designated States (national): AE, AG, AL, AM, AT, AU, AZ, BA, BB, BG, BR, BY, BZ, CA, CH, CN, CO, CR, CU, CZ, DE, DK, DM, DZ, EC, EE, ES, FI, GB, GD, GE, GH, GM, HR, HU, ID, IL, IN, IS, JP, KE, KG, KP, KR, KZ, LC, LK, LR, LS, LT, LU, LV, MA, MD, MG, MK, MN, MW, MX, MZ, NO, NZ, OM, PH, PL, PT, RO, RU, SD, SE, SG, SI, SK, SL, TJ, TM, TN, TR, TT, TZ, UA, UG, US, UZ, VN, YU, ZA, ZM, ZW.

(84) Designated States (regional): ARIPO patent (GH, GM, KE, LS, MW, MZ, SD, SL, SZ, TZ, UG, ZM, ZW), Eurasian patent (AM, AZ, BY, KG, KZ, MD, RU, TJ, TM), European patent (AT, BE, CH, CY, DE, DK, ES, FI, FR, GB, GR, IE, IT, LU, MC, NL, PT, SE, TR), OAPI patent (BF, BJ, CF, CG, CI, CM, GA, GN, GQ, GW, ML, MR, NE, SN, TD, TG).

Published:
— with international search report

For two-letter codes and other abbreviations, refer to the "Guidance Notes on Codes and Abbreviations" appearing at the beginning of each regular issue of the PCT Gazette.

(54) Title: APPARATUS AND METHOD FOR DETERMINING ORGAN PERFUSION

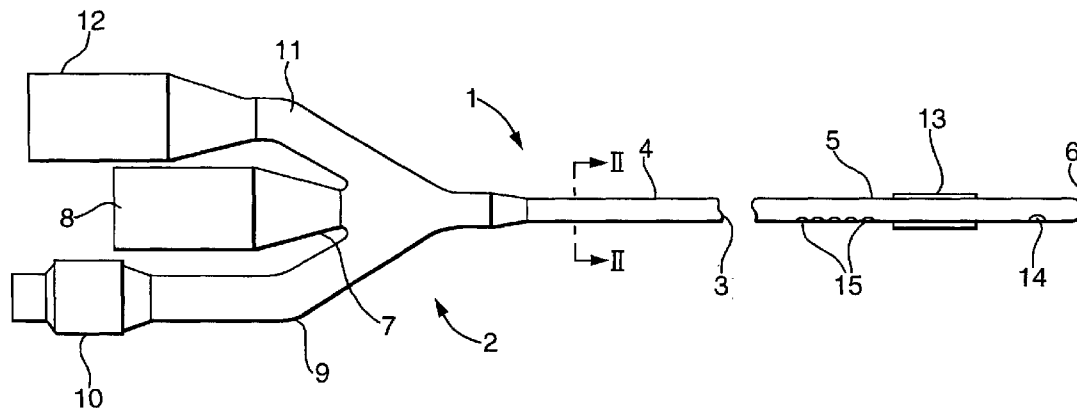

(57) Abstract: An apparatus for monitoring an analyte comprises a urethral catheter (1), which has positioning means (13) for positioning the catheter within the urethra, and a sensor (19). In use the sensor (19) is held in close proximity to a urethral wall U, permitting monitoring of the analyte level in the urethral wall thereby providing information which may be useful in evaluation of the vita conditions of a patient.



WO 02/096286 A1

APPARATUS & METHOD FOR DETERMINING ORGAN PERFUSION

This invention relates to an apparatus and a method for determining analyte perfusion in human and animal organs.

5 Measurements of oxygen and carbon dioxide tension within various organs in the body have been proposed as an indicator of the onset of shock or sepsis. For example, measurements have been made for this purpose of CO₂ levels within the gut and a correlation has been claimed between
10 such measurements and dysfunction of vital organs, see, for example, US Patent 5,456,251 (Fiddian-Green). .

Oxygen partial pressure has also been measured within the bladder and the results indicate a correlation between reduction in the bladder pO₂, lowered blood pressure (BP),
15 reduced aortic blood flow (ABF) and renal blood flow (RBF). A method and apparatus for performing bladder oxygen monitoring for such purpose is described in US Patent 5,389,217 (Singer). Both of the above procedures are based on the premise that, when the body suffers major perfusion
20 failure, e.g. as a result of trauma, infection, cardiac or obstructive shock, blood flow to the vital organs such as the brain, lungs, heart etc is increased, while blood flow to the less important organs is reduced. In the blood flow to non-vital organs this is manifested by a reduction in
25 oxygen and an increase in acidosis and provides an early indication of the onset of critical conditions giving more warning to an intensive care team of the need to take emergency measures to stabilise a patient.

Measurement of CO₂ in the gut has the disadvantage that
30 introduction of a sensor into such a position is generally invasive and requires a separate and complex procedure to install it in the correct position. While the procedure

described in the Singer US patent for measurement of oxygen partial pressure in the bladder has yielded impressive results, the particular system described necessarily involves some difficulty in precise location of the sensor
5 in contact with the wall of the bladder.

The present invention is directed to a method and apparatus for determining the onset of shock in a patient by monitoring at least one analyte, for example, by monitoring pCO₂ and/or pO₂ and/or pH, in a manner which overcomes or
10 mitigates the problems described above.

It has now been found in tests on animal models that a sensor placed against the wall of the urethra responds in a similar and simultaneous way to sensors placed against the bladder wall, oesophageal, subcutaneous and skeletal tissue.
15 An in vitro study has shown that the contractile response of the urethra to ischemic injury is more sensitive than that of the bladder, offering a possible explanation for the development and symptoms of urinary incontinence secondary to sphincteric damage before bladder dysfunction is present.
20 (Bratslavsky G et al (2001), J. Urol. 2001:165(6):2086-90). Bratslavsky et al attribute the observed difference in sensitivity of the bladder and urethra to differences in bladder and urethra innervation.

In accordance with one aspect of the present invention,
25 concentration of an analyte, for example, hydrogen ions (pH), oxygen or carbon dioxide, in the epithelial tissue of the urethra is measured by placing a sensor within the urethra. That may be achieved by incorporating a sensor in a urethral catheter so that, when the catheter is located in
30 the normal way for draining urine from the bladder, the sensor is positioned in close proximity to the urethral wall by, for example, incorporating it within an appropriate

section of the catheter. By positioning the sensor at or on the surface of the catheter or within a section which is capable of transmitting the analyte, the concentration within the epithelial tissue can be measured. For the purposes of this invention, the term "analyte" includes oxygen, carbon dioxide and hydrogen ions (pH).

The invention provides an apparatus for monitoring an analyte comprising a urethral catheter, the urethral catheter comprising positioning means for positioning the catheter in the urethra, and a sensor which is so located that, when the catheter is positioned within the urethra by the positioning means, the sensor is held in close proximity to a urethral wall.

The apparatus is so arranged that in use the sensor is held in close proximity to a urethral wall. The sensor may be incorporated within a void in the catheter, a portion of the catheter wall being capable of transmitting the analyte, the concentration of which is to be measured. In use, that portion of the wall of the catheter will be placed against the urethral wall.

In the context of this specification, the term "in close proximity to" referring to the relative positioning of the sensor and the urethral wall is to be understood as including direct contact and also including indirect contact in the sense that there may be an intervening medium between the sensor and the urethral wall provided that the intervening medium is capable of transporting the analyte from the urethral wall to the sensor. It may be preferred for the sensor to be separated from the urethral wall, the separation distance and intervening medium being such that a material amount of analyte is able to reach the sensor. It will be appreciated that "a material amount" of analyte will

in practice be an amount which is sufficient both to be detectable and to permit changes in the analyte concentration to be effectively monitored. Where the sensor is located within the catheter, the catheter wall may constitute at least a part of said intervening medium. In practice, however, there will generally also be a small volume of fluid between the urethral wall and the sensor. That fluid may be a secretion from the urethral wall. It may, however, be found expedient to deliver a small volume of suitable fluid, for example physiological saline solution, via the catheter.

It is a particular advantage of the apparatus of the invention that reliable monitoring of analyte in the urethral wall can be achieved, using a non-invasive technique. The monitoring of analyte that has diffused through a catheter wall rendered permeable to the analyte and/or through an intervening medium between the catheter wall and the urethral wall (for example, a thin layer of fluid) is believed to give a reliable indication of variations in the analyte concentration in the urethral wall. It will be appreciated that, based on the known principles of diffusion, it will be desirable to position the sensor close to the urethral wall in order to restrict any difference between the measured concentration of the analyte and the actual concentration in the urethral wall. Advantageously, the sensor is so arranged that at least a sensing surface is outside the catheter wall. In an especially preferred arrangement, the sensor is contained within the catheter when the catheter is introduced into the patient and, when the catheter is in position, the sensor can be advanced along the catheter and outwardly therefrom via a suitably positioned exit port. The sensor may in use

be within a void of the catheter. In that case, the sensor may advantageously abut a region of the catheter wall that is capable of transmitting analyte. Preferably, the void also includes a fluid which is capable of transmitting the analyte to be measured, the sensor being at least partly immersed in that fluid.

The positioning means may be any positioning device that is suitable for securing the catheter substantially within the urethra with the distal end of the catheter positioned in the bladder and the sensor (located in or outside the catheter) being positioned within the urethra. Advantageously, the positioning means comprises an inflatable balloon, cuff or similar device. Advantageously, the positioning means, especially an inflatable balloon or cuff, is arranged to fit snugly at the neck of the bladder, anchoring the catheter in place and substantially preventing urine from the bladder passing between the catheter and the wall of the urethra, thus substantially eliminating any undesirable influence of urine contamination on analyte measurement.

In an especially preferred apparatus of the invention, the urethral catheter comprises a sensor device which is capable of monitoring at least pH, pO_2 and pCO_2 . Devices capable of measuring all those three analytes are known and used, for example, in the blood analyte monitors sold under the trade name Paratrend (Diametric Medical Inc.). Advantageously, the sensor device also includes a temperature-measuring device, for example, a thermocouple.

Advantageously, the catheter comprises a pH sensor positioned within a void in the catheter. In that case, a portion of catheter wall in the region of the pH sensor may be perforated by one or more apertures. Advantageously, the

catheter comprises a pO₂ sensor, an adjacent portion of the catheter wall being of a material permeable to oxygen. Advantageously, the catheter comprises a CO₂ sensor, an adjacent portion of the catheter wall being a of material
5 permeable to carbon dioxide.

Urethral catheters are widely fitted as a matter of course to moderately ill patients, especially after an operation or suffering trauma. The invention thus offers a non-invasive technique for monitoring analyte indicative of
10 the condition of the patient, in many cases without necessitating any additional step for introduction of a monitoring device. Further, urethral catheters are normally a close fit within the urethra so that there is no ambiguity in the position of the sensor in relation to the urethral
15 wall. So long as the sensor is positioned in a portion of the catheter which would lie within the urethra, the sensor is automatically positioned in a known relationship with the urethral wall. This is in contrast to the apparatus described in the above-cited Singer US patent, in which the
20 sensor requires to be carefully positioned for contact with the wall of the bladder.

A further advantage of the apparatus of the invention is that the sensor can be protected by being positioned within or on the urethral catheter and covered with a
25 material which is permeable to the analyte.

The invention also provides an apparatus for measuring at least one analyte selected from pH, oxygen and carbon dioxide in urethra epithelial tissue which comprises an urethral catheter having an inflatable device for securing
30 the distal end within the bladder and a sensor so positioned with respect to the catheter that, in use, the sensor lies proximally of the inflatable device within the urethra and

in the region of the urethral wall. Moreover, the invention provides a method of monitoring the vital conditions of a patient, comprising positioning a sensor in the urethra of the patient for measuring a concentration of an analyte in
5 the urethral tissue.

It is known that bladder epithelial oxygen tension (BEOT) shows a strong inverse correlation with vital perfusion conditions of the body. The present invention is predicated on the observation that urethral epithelial O₂
10 tension and, additionally or instead, urethral epithelial CO₂ tension can be used as an indication of gaseous perfusion in vital organs and therefore give a pre-warning of critical conditions in a patient.

Three illustrative embodiments of the invention will
15 now be described with reference to the accompanying drawings, in which:-

Fig. 1 is a side elevation of an urethral catheter having three lumens;

Fig. 2 is a transverse section through a proximal
20 portion of the catheter of Fig. 1;

Fig. 3 is an enlarged view from below of a distal portion of the catheter of Fig. 1;

Fig. 4 is a schematic view, partly in section, of a part of the distal portion;

25 Fig. 5 is a schematic view of the catheter positioned within the urethra of a patient.

Fig. 6 is another form of three-lumen catheter;

Fig. 7 is a side elevation of a second urethral catheter;

30 Fig. 8 is a view of the second catheter seen from below;

Fig. 9 is a view on an enlarged scale of the portion of the second catheter circled in Fig. 7; and

Fig. 10 is an enlarged section taken along the line A-A in Figure 8.

5 With reference to Fig. 1, a urethral catheter 1 is formed as a three-lumen catheter having a connector portion 2 and an elongate body 3. The elongate body 3 has a proximal portion 4, adjacent to connector portion 2, and distal portion 5 including tip 6. The body 3 has a urine
10 drainage lumen communicating via a cannula 7 with urine drainage channel connector 8, an air lumen communicating via cannula 9 with air lumen connector 10, and a sensor lumen communicating via cannula 11 with sensor lumen connector 12. The urine drainage lumen connector 8 is arranged to be
15 attachable to a suitable urine collection device of any suitable kind. The air lumen connector 10 is arranged to be attachable to a suitable source of air, for example a syringe, for inflation of a catheter positioning device as will be described further below. The sensor lumen connector
20 12 is arranged for attachment to a sensor monitoring device, which may be for example a device capable of generating light and/or other signals to one or more sensor devices and of receiving information fed back from said sensor(s). Thus, the sensor lumen connector 12 may include a connection
25 device for connecting one or more optical fibres.

The distal portion 5 of the catheter is provided with an inflatable balloon 13, which is shown deflated in Fig. 1. Distally of the balloon 13, and adjacent to the tip 6, is a lateral urine drainage aperture 14. Proximally of the
30 balloon 13, is provided a longitudinally extending row of apertures 15. The apertures 15 may suitably be of about 0.4mm diameter at equal pitches of 1mm (the drawing of Fig.

1 is not to scale). Other sizes and/or patterns of apertures may, however, be used. Where the analyte to be measured is hydrogen ion concentration, the apertures 15 are filled with a hydrophilic substance which provides a pathway
5 for water-borne hydrogen ions to pass into the catheter. Suitable hydrophilic substances include hydrophilic gels, for example, a polyacrylamide gel.

Referring now to Fig. 2, the elongate body 3 defines three longitudinally extending lumens. Urine drainage
10 channel 16 extends between drainage aperture 14 and urine drainage lumen connector 8 for drainage of urine from the aperture 14. Air lumen 17 extends from the air lumen connector 10 to the inflatable balloon 13 for the introduction of air to inflate the balloon 13 when required.
15 A third lumen, sensor lumen 18, extends from the sensor lumen connector 12 along the elongate body 3 into the distal portion 5 and is closed at or in the vicinity of the balloon 13. The apertures 15 in the wall of the catheter are arranged to be in communication with the sensor lumen 18 in
20 order to permit fluid carrying an analyte to flow into the sensor lumen 18 when the wall of the catheter is, in use, pressed into intimate contact with the wall of the urethra. The cross-sectional shape of each lumen may vary from that shown, although in the case of the sensor lumen it may be
25 preferred for at least the outermost surface to be substantially parallel to the outer catheter wall in at least the region of the apertures 15.

The distal portion 5 of the catheter 1 is shown in enlarged view in Fig. 3, in which the balloon 13 is shown
30 inflated.

Referring to Fig. 4, a sensor 19 is located within sensor lumen 18 adjacent to the row of apertures 15 for receiving fluid which flows there through.

5 Additionally, or as an alternative to forming apertures in the wall of the catheter, the wall in the region in which in use the sensor is located may be made from a material, for example, a membrane, which is permeable to an analyte gas of interest. For example, a membrane made from a silicone rubber will be permeable to CO₂. The sensor may be
10 of the optical type used to measure oxygen or carbon dioxide partial pressure or, alternatively, of the electrochemical type. Both types of sensors are available from Diametrics Medical Limited and are included in pCO₂ and pO₂ monitoring equipment marketed under the trade marks "Continucath" and
15 "Paratrend". Preferably, the sensors used are of the optical type since these can be made as solid state sensors which do not consume chemicals. The preferred type of sensors include a chemical indicator which is sensitive to the gaseous analyte and undergoes a colour change or
20 fluorescent properties depending on the concentration of the analyte. The chemical indicator is preferably a fluorescent dye which is quenched by the gaseous analyte. Optical fibres (not shown in Fig. 1 but shown in Fig. 7) are employed for conducting light of the wavelength at which the
25 dye fluoresces and for conducting the returning beam to a detector remote from the catheter. The intensity of the fluorescence can be used as a continuous measure of the concentration of the analyte, after any necessary calibration of the sensor.

30 In the case of some sensors, particularly pH sensors, it may be desirable to incorporate a reservoir of saline or water around the sensor within the sensor lumen 18. This is

to ensure that hydrogen ions can diffuse into contact with the sensor.

Fig. 5 shows the distal portion of the catheter in position in a patient. In use, the catheter 1 will be introduced along the urethra into the bladder in the usual way for installing a urethral catheter so that the tip 6 lies within the patient's bladder B and liquid may be drained through the drainage lumen 16. On inflation of the balloon 13 at the neck N of the bladder B, the distal tip 6 is held clear from the walls of the bladder B and a major portion of the catheter which lies proximally of the balloon 13 will be within the urethra U.

A second form of urethral catheter according to the invention is shown in Fig. 6. The catheter of Fig. 6 is essentially the same as that of Figs. 1 to 5 except that the sensor device is arranged to protrude outwardly, in use, from the sensor lumen and to lie between the catheter and the urethral wall. It will be appreciated, therefore, that the provision of the apertures 15 of the embodiment of Figs. 1 to 5 is unnecessary and that, instead, there is provided in the wall of the catheter an aperture through which the sensor can be advanced once the catheter is in place in the urethra.

The present invention has the advantage that by ensuring that the catheter is positioned with the inflatable device such as a balloon or cuff anchoring the catheter in the neck of the urethra, the location of the sensor is known with certainty and consistent measurements can be made of the analyte perfusion concentration within the urethral epithelial tissue. Furthermore those measurements would be expected to give a good correlation with analyte perfusion concentration within the bladder epithelial tissue, whilst

offering the above-described simplicity and consistency of location, and to critical conditions a possibility of slightly improved tissue responsiveness as compared with the bladder. The invention also offers the possibility of essentially continuous monitoring of the analyte or analytes, providing the clinician with an effectively instantaneous measurement of the current value as well as an indication of the historical development of the analyte level.

10 Urethral catheters of the general type described above which are anchored into a patient's bladder using an inflatable device are commercially available as Foley catheters. The catheters of the invention, including a sensor, could therefore be regarded as modified Foley
15 catheters. Foley catheters are conventionally fitted to moderately ill patients, especially after an operation or suffering trauma, e.g. as a result of haemorrhage. The catheter can be introduced using conventional procedures so that the installation of the catheter does not involve any
20 novel steps or manipulations. The only additional requirement is that the cable or optical fibres which are connected to the sensor will project, e.g. from the connector 12 and require connection to a monitor. The familiar Luer type locks can be used for this purpose. This
25 is a clear advantage since when nursing critically ill patients, it is desirable to reduce the number of additional connections and manipulations which need to be made in the critical care environment.

The positioning of the catheter is reliably
30 reproducible, the position being essentially governed by the air-filled balloon which, in practice, is arranged to fit snugly at the neck of the bladder at the entrance to the

urethra. Thus, once the balloon is inflated in the correct position monitoring takes place at a fixed distance proximal to the neck of the bladder.

Referring to Fig. 7, a second form of urethral catheter 5 101 is provided which is a bi-lumen catheter having a first lumen 117 for inflating a locating balloon 113 (shown inflated in Figs. 7 and 8, but omitted for clarity in Fig. 9). Lumen 117 is connected with a cannula 109 and terminates in a connector 110 to which it may be connected 10 to means for inflating the balloon such as a syringe.

Lumen 116 is connected at the proximal end with a cannula 107 which is linked to a connector 108 for connection to tubes for draining urine from the bladder. In use, the catheter 101 will be introduced along the urethra 15 into the bladder in the usual way for installing a urethral catheter so that the distal end 106 lies within the patient's bladder and liquid may be drained through the drainage lumen 116. On inflation of the balloon 113, the distal end is held clear from the walls of the bladder and a 20 major portion of the catheter which lies proximally of the balloon 113 will be within the urethra. The side wall of the catheter is perforated over a section 115 which lies proximally of the balloon 113, the perforations extending into the drainage lumen 116.

As shown in Fig. 9, a pattern of aligned holes 115 of 25 about 0.4mm diameter are provided at equal pitches of 1mm to permit fluid to flow into the drainage lumen 116 while the wall of the catheter is pressed into intimate contact with the wall of the urethra. It will be appreciated, however, 30 that other sizes and patterns of holes can be provided into the drainage lumen 116. The holes may be filled with a hydrophilic material, for example, a polyacrylamide gel. A

further hole or holes 114 is formed in the distal portion 105 of the catheter distally of balloon 113. The hole 114 also communicates with the drainage lumen 116 to drain urine from the bladder through the cannula 107 away from the patient.

A sensor (not shown) is positioned within the drainage lumen 116 in the vicinity of the perforated section 115 so that the sensor is exposed to gases present in tissue in the urethral wall. Communication means, for example one or more cables or optical fibres 120, for signals from the sensor extend individually along the catheter within the drainage lumen 116 from the sensor to the connector 108, which is arranged for connection to a sensor monitoring device. As described above with reference to Figs. 1 to 5, as an alternative to forming apertures in the wall of the catheter, the wall at this point may be made from a material which is permeable to the analyte gas of interest. In practice, however, it will be preferred in the case of the two-lumen catheter of Figs. 7 to 10 for the sensor to be so arranged that it protrudes outside the catheter, and may then contact directly the urethral wall, thus avoiding the influence on the measurements of urine passing through the drainage lumen. In that case, the aligned holes 115 may be absent and may be replaced by an aperture which is positioned and dimensioned to permit at least a sensing portion of the sensor to be advanced therethrough and located in analogous manner to that shown in Fig. 6 once the catheter has been positioned in the urethra. Suitable sensor devices for use in the catheter of Figs. 7 to 10 are, for example, those described above with reference to Figs. 1 to 5.

CLAIMS

1. An apparatus for monitoring an analyte comprising a urethral catheter, the urethral catheter comprising
5 positioning means for positioning the catheter in the urethra, and a sensor which is so located that, when the catheter is positioned within the urethra by the positioning means, the sensor is held in close proximity to a urethral wall.
- 10 2. An apparatus according to claim 1, wherein the positioning means comprises an expansible device arranged for holding a distal end of the catheter in the bladder in use of the catheter and the sensor is located proximally of the expansible device so that it lies within the urethra.
- 15 3. An apparatus according to claim 1 or claim 2, in which the positioning means is an inflatable balloon.
4. An apparatus according to claim 1 or 2 wherein the sensor is capable of measuring at least one analyte selected from pH, pO₂ and pCO₂.
- 20 5. An apparatus according to any preceding claim in which at least one analyte can be measured using an optical detection method.
6. An apparatus according to claim 4 or claim 5, in which at least two analytes can be measured and a respective
25 sensor is present for measuring each of said at least two analytes.
7. An apparatus according to any one of the preceding claims, in which at least one sensor is positioned within the catheter and a region of the catheter wall in the
30 vicinity of a said sensor is capable of transmitting an analyte to be measured by that sensor.

8. An apparatus according to claim 7, in which a pH sensor is positioned within the catheter and a region of the catheter wall is perforated or is porous to hydrogen ions.

9. An apparatus according to claim 7, in which a sensor
5 for dissolved carbon dioxide is located within the catheter and at least a region of the catheter wall is permeable to carbon dioxide.

10. An apparatus according to anyone of claims 7 to 9, in which a sensor for dissolved oxygen is located within the
10 catheter and at least a region of the catheter wall is permeable to oxygen.

11. An apparatus according to claim 10 wherein the sensor is an optical device in which a fluorescent material is quenched by the analyte.

12. An apparatus according to any preceding claim, in which
15 pO₂, pCO₂ and pH can be measured by a common sensor device.

13. An apparatus according to any preceding claim, which further comprises a temperature sensing device for measuring temperature.

14. Apparatus for measuring at least one analyte selected
20 from pH, oxygen and carbon dioxide in urethra epithelial tissue which comprises an urethral catheter having an inflatable device for securing the distal end within the bladder and a sensor so positioned with respect to the
25 catheter that, in use, the sensor lies proximally of the inflatable device within the urethra and in the region of the urethral wall.

15. An apparatus according to any one of the preceding claims wherein the urethral catheter is a triple lumen
30 catheter comprising a first lumen for inflating a positioning device, a second lumen for draining urine and a

third lumen for housing one or more sensors in close proximity to the urethral wall.

16. An apparatus for monitoring an analyte substantially as described herein with reference to and as illustrated by any
5 one of Figs. 1 to 95, Fig. 6 or Figs. 7 to 10.

17. A method of monitoring the vital conditions of a patient, comprising positioning a sensor in the urethra of the patient for measuring a concentration of an analyte in the urethral tissue.

10 18. A method according to claim 17, in which the sensor is introduced into the urethra in association with a catheter.

19. A method according to claim 18, in which urine is drained from the patient through a lumen of the catheter and closure means are provided distally of the sensor
15 substantially to prevent passage of urine into the urethra other than within said lumen.

20. Use in the manufacture of equipment for detecting onset of shock of apparatus for measuring the concentration of analyte selected from pH, oxygen and carbon dioxide in
20 epithelial tissue in the urethral wall.

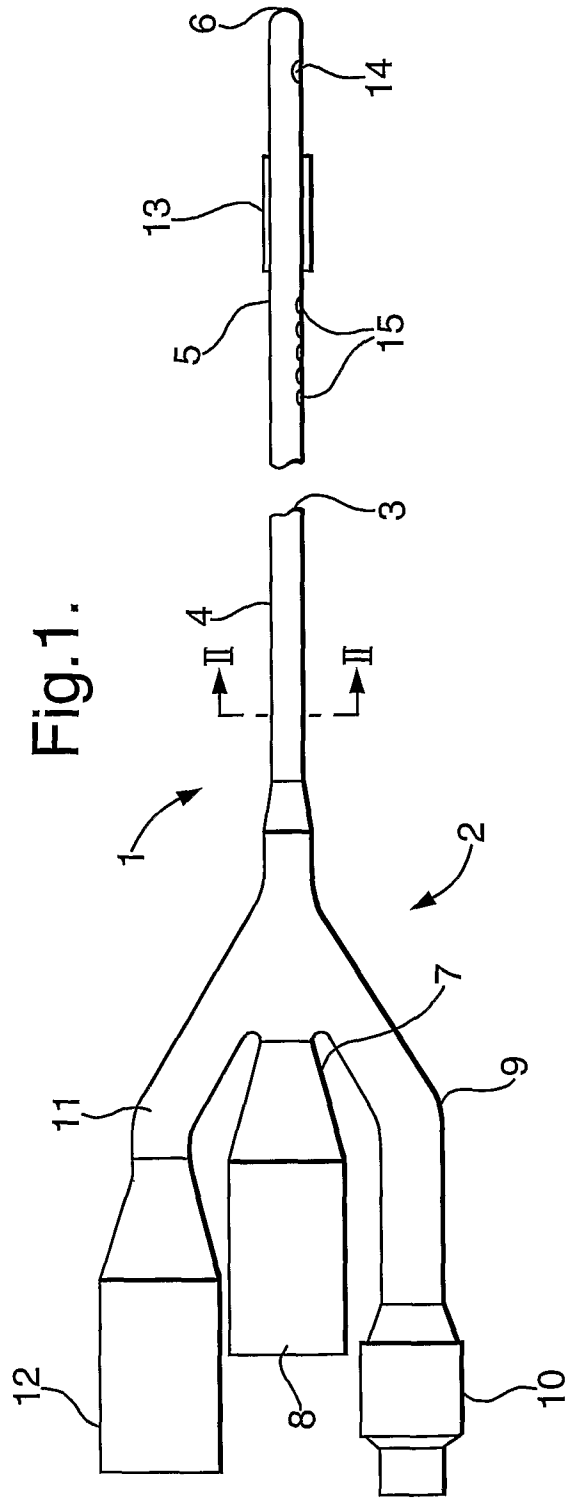

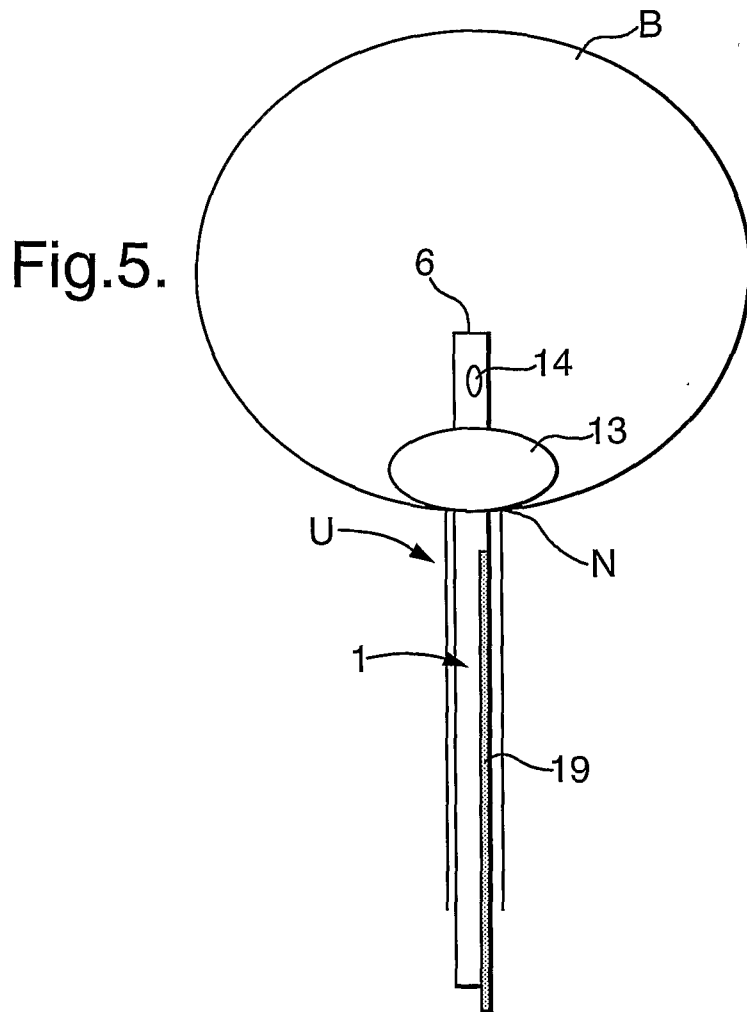
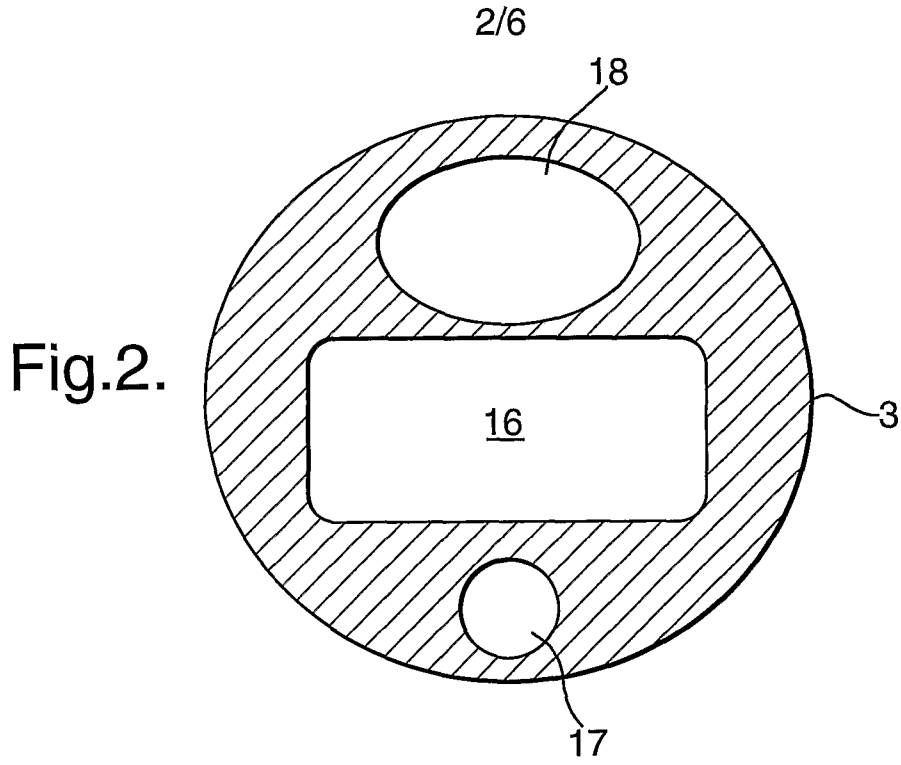

Fig.3.

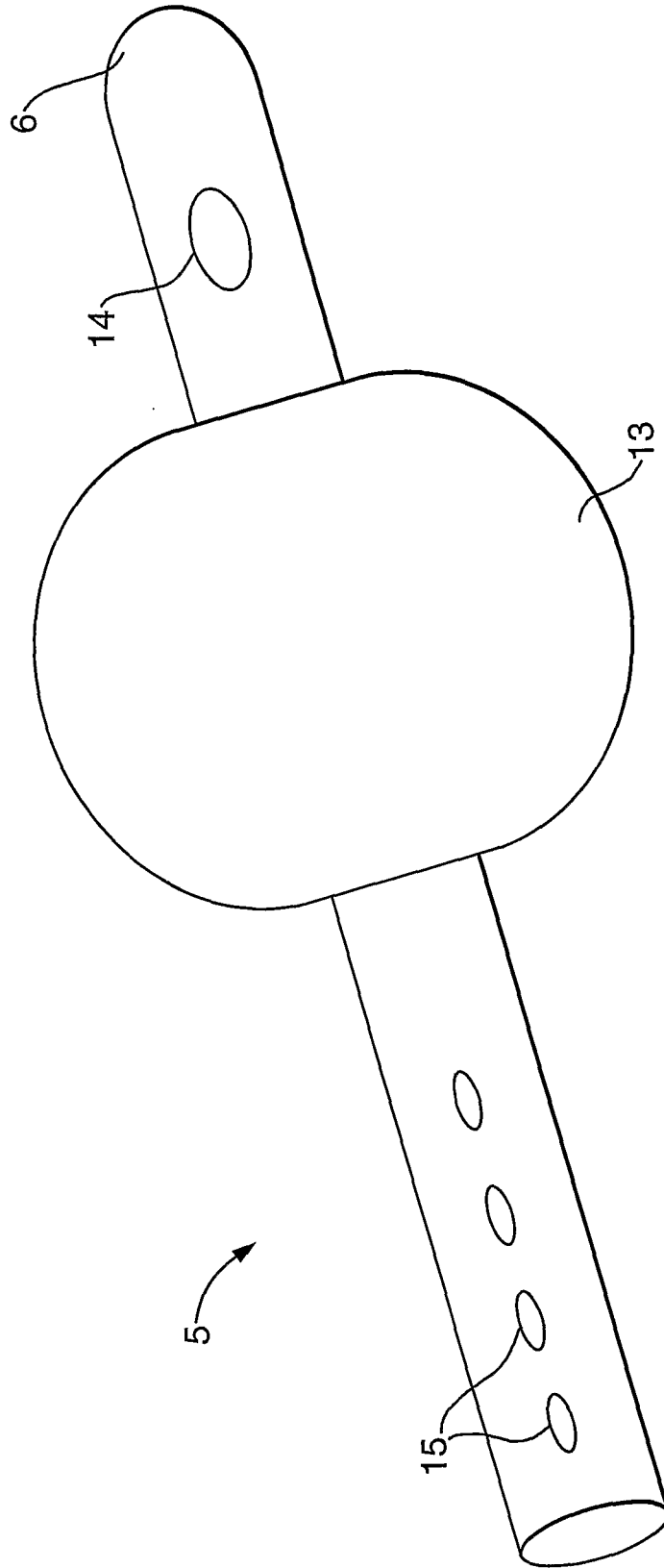

Fig.4.

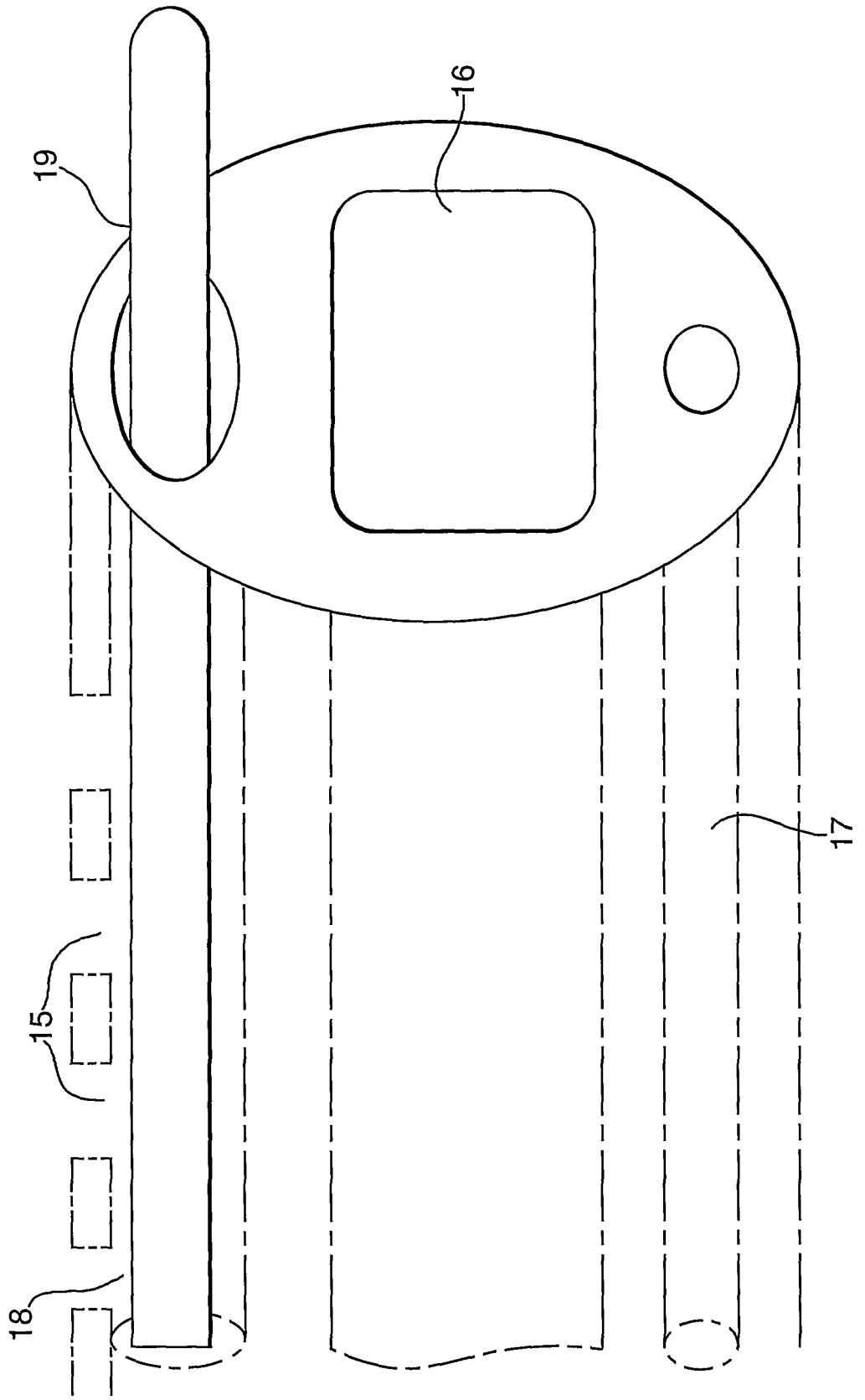

Fig.6.

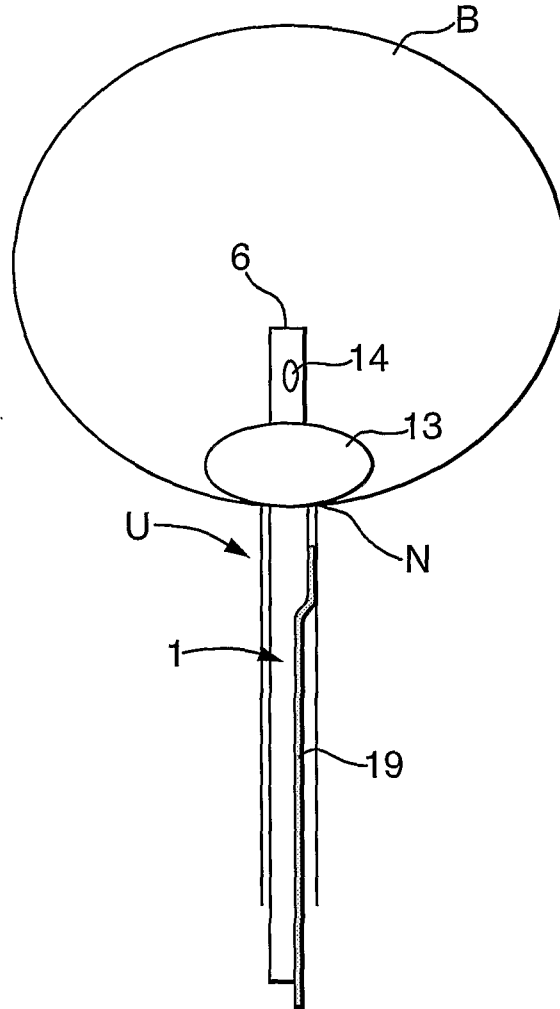
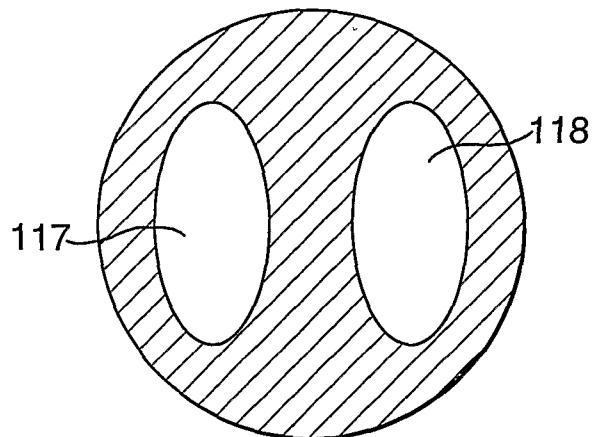
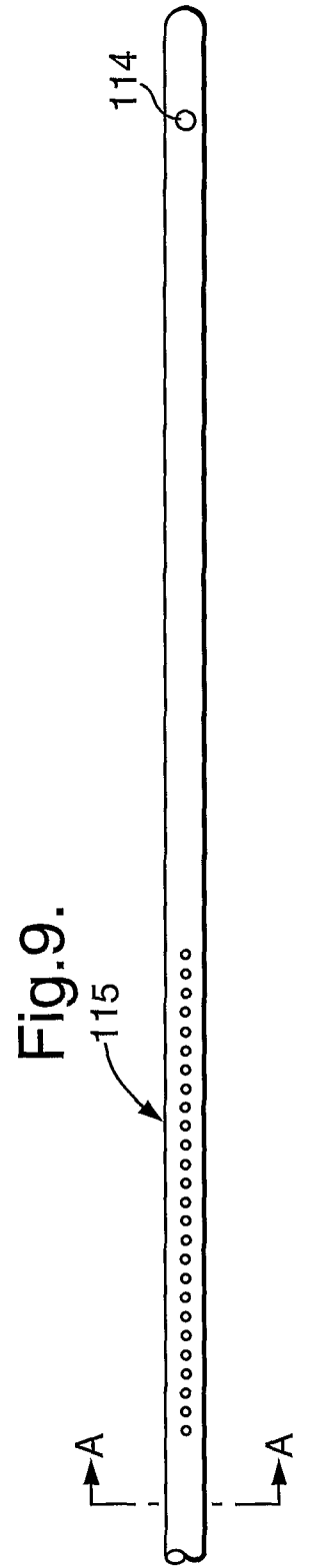
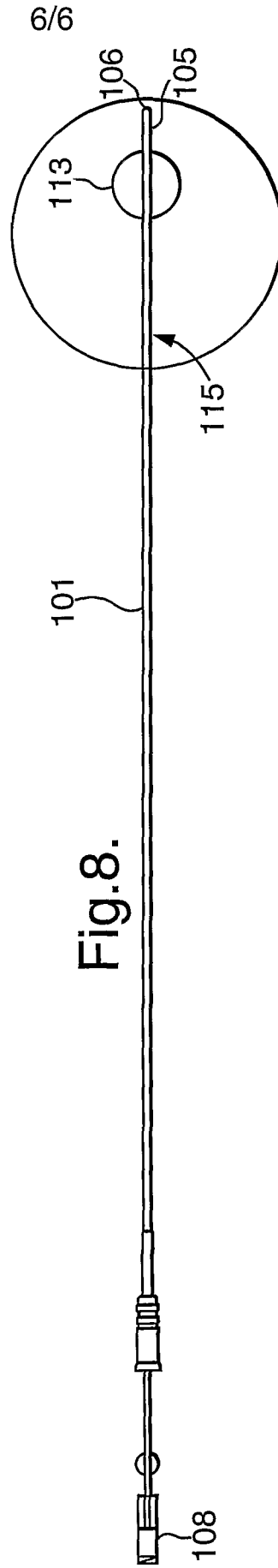
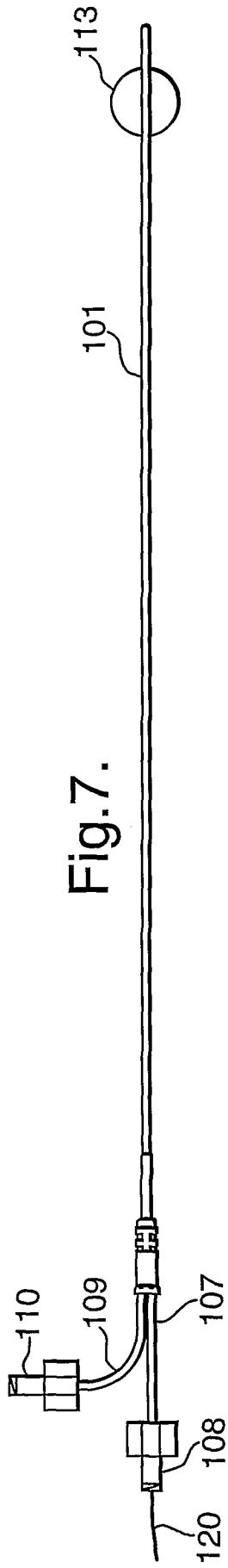

Fig.10.





INTERNATIONAL SEARCH REPORT

International Application No
PCT/GB 02/02546

A. CLASSIFICATION OF SUBJECT MATTER
IPC 7 A61B5/03 A61B5/00

According to International Patent Classification (IPC) or to both national classification and IPC

B. FIELDS SEARCHED

Minimum documentation searched (classification system followed by classification symbols)
IPC 7 A61B A61M

Documentation searched other than minimum documentation to the extent that such documents are included in the fields searched

Electronic data base consulted during the international search (name of data base and, where practical, search terms used)

EPO-Internal, WPI Data, PAJ

C. DOCUMENTS CONSIDERED TO BE RELEVANT

Category *	Citation of document, with indication, where appropriate, of the relevant passages	Relevant to claim No.
X Y A	US 5 916 153 A (RHEA JR W GARDNER) 29 June 1999 (1999-06-29) column 1, line 66 -column 2, line 22 column 2, line 44 -column 3, line 53; tables 1-5	1-5,7, 11,13-16 12 20
X	---- WO 99 18851 A (NILSEN EGIDIJA R) 22 April 1999 (1999-04-22) page 2, line 24 -page 3, line 12 page 5, line 16 -page 7, line 23; tables 5,6	1-3,7
Y A	---- US 6 029 076 A (HOLTE BO ET AL) 22 February 2000 (2000-02-22) column 8, line 39 -column 9, line 45 column 11, line 57 -column 13, line 25; tables 10,11 ---- -/--	12 4,9,10, 13,15,20

Further documents are listed in the continuation of box C.

Patent family members are listed in annex.

* Special categories of cited documents :

- *A* document defining the general state of the art which is not considered to be of particular relevance
- *E* earlier document but published on or after the international filing date
- *L* document which may throw doubts on priority claim(s) or which is cited to establish the publication date of another citation or other special reason (as specified)
- *O* document referring to an oral disclosure, use, exhibition or other means
- *P* document published prior to the international filing date but later than the priority date claimed

- *T* later document published after the international filing date or priority date and not in conflict with the application but cited to understand the principle or theory underlying the invention
- *X* document of particular relevance; the claimed invention cannot be considered novel or cannot be considered to involve an inventive step when the document is taken alone
- *Y* document of particular relevance; the claimed invention cannot be considered to involve an inventive step when the document is combined with one or more other such documents, such combination being obvious to a person skilled in the art.
- *&* document member of the same patent family

Date of the actual completion of the international search

16 September 2002

Date of mailing of the international search report

20/09/2002

Name and mailing address of the ISA

European Patent Office, P.B. 5818 Patentlaan 2
NL - 2280 HV Rijswijk
Tel. (+31-70) 340-2040, Tx. 31 651 epo nl,
Fax: (+31-70) 340-3016

Authorized officer

Weih, J

INTERNATIONAL SEARCH REPORT

International Application No

PCT/GB 02/02546

C.(Continuation) DOCUMENTS CONSIDERED TO BE RELEVANT

Category °	Citation of document, with indication, where appropriate, of the relevant passages	Relevant to claim No.
A	US 6 175 751 B1 (MAIZES ALLEN) 16 January 2001 (2001-01-16) column 2, line 43 -column 3, line 33; table 1 -----	1-5, 10, 14

INTERNATIONAL SEARCH REPORT

Information on patent family members

International Application No

PCT/GB 02/02546

Patent document cited in search report		Publication date	Patent family member(s)	Publication date
US 5916153	A	29-06-1999	NONE	
WO 9918851	A	22-04-1999	NO 961359 A	03-10-1997
			WO 9918851 A1	22-04-1999
			AU 5235698 A	03-05-1999
			SI 20409 A	30-06-2001
US 6029076	A	22-02-2000	AU 706939 B2	01-07-1999
			AU 6080298 A	02-07-1998
			AU 692443 B2	11-06-1998
			AU 6448494 A	11-10-1994
			AU 685108 B2	15-01-1998
			AU 6521294 A	11-10-1994
			CA 2152272 A1	29-09-1994
			CA 2152273 A1	29-09-1994
			EP 0690693 A1	10-01-1996
			EP 0690695 A1	10-01-1996
			JP 8511177 T	26-11-1996
			JP 8512213 T	24-12-1996
			WO 9421163 A1	29-09-1994
			WO 9421164 A1	29-09-1994
			US 6238339 B1	29-05-2001
			US 5456251 A	10-10-1995
			US 6334064 B1	25-12-2001
			US 5415165 A	16-05-1995
			US 6010453 A	04-01-2000
			US 5526809 A	18-06-1996
			US 5788631 A	04-08-1998
US 6175751	B1	16-01-2001	NONE	

专利名称(译)	用于确定器官灌注的装置和方法		
公开(公告)号	EP1395175A1	公开(公告)日	2004-03-10
申请号	EP2002730466	申请日	2002-05-31
[标]申请(专利权)人(译)	DIAMETRICS医疗		
申请(专利权)人(译)	DIAMETRICS医疗有限公司		
当前申请(专利权)人(译)	DIAMETRICS医疗有限公司		
[标]发明人	BARNETT NICK		
发明人	BARNETT, NICK		
IPC分类号	A61B5/00 A61B5/01 A61B5/03 A61F2/84		
CPC分类号	A61B5/14542 A61B5/14539 A61B5/1459 A61B5/1473 A61B5/202 A61B5/205 A61B5/412 A61B5/6853		
优先权	2001013388 2001-06-01 GB		
外部链接	Espacenet		

摘要(译)

一种用于监测分析物的装置包括尿道导管(1)，其具有用于将导管定位在尿道内的定位装置(13)，以及传感器(19)。在使用中，传感器(19)紧靠尿道壁U保持，允许监测尿道壁中的分析物水平，从而提供可用于评估患者的病情状况的信息。