

(19) World Intellectual Property Organization
International Bureau



(43) International Publication Date
5 April 2001 (05.04.2001)

PCT

(10) International Publication Number
WO 01/22868 A1

(51) International Patent Classification⁷: A61B 5/00, 5/022

(74) Agent: REINHOLD COHN AND PARTNERS; P.O. Box 4060, 61040 Tel-Aviv (IL).

(21) International Application Number: PCT/IL00/00603

(22) International Filing Date:
27 September 2000 (27.09.2000)

(81) Designated States (*national*): AE, AG, AL, AM, AT, AU, AZ, BA, BB, BG, BR, BY, BZ, CA, CH, CN, CR, CU, CZ, DE, DK, DM, DZ, EE, ES, FI, GB, GD, GE, GH, GM, HR, HU, ID, IL, IN, IS, JP, KE, KG, KP, KR, KZ, LC, LK, LR, LS, LT, LU, LV, MA, MD, MG, MK, MN, MW, MX, MZ, NO, NZ, PL, PT, RO, RU, SD, SE, SG, SI, SK, SL, TJ, TM, TR, TT, TZ, UA, UG, US, UZ, VN, YU, ZA, ZW.

(25) Filing Language: English

(26) Publication Language: English

(30) Priority Data:
09/407,390 28 September 1999 (28.09.1999) US

(84) Designated States (*regional*): ARIPO patent (GH, GM, KE, LS, MW, MZ, SD, SL, SZ, TZ, UG, ZW), Eurasian patent (AM, AZ, BY, KG, KZ, MD, RU, TJ, TM), European patent (AT, BE, CH, CY, DE, DK, ES, FI, FR, GB, GR, IE, IT, LU, MC, NL, PT, SE), OAPI patent (BF, BJ, CF, CG, CI, CM, GA, GN, GW, ML, MR, NE, SN, TD, TG).

(72) Inventors; and

(75) Inventors/Applicants (*for US only*): FINAROV, Alexander [IL/IL]; Kovshey Ha-Hermon 1/10, 76000 Rehovot (IL). KLEINMAN, Yossie [IL/IL]; Hacalaniot 7, 76450 Rehovot (IL). FINE, Ilya [IL/IL]; Herzl Street 59/6, 76450 Rehovot (IL).

Published:

- With international search report.
- Before the expiration of the time limit for amending the claims and to be republished in the event of receipt of amendments.

[Continued on next page]

(54) Title: AN OPTICAL DEVICE FOR NON-INVASIVE MEASUREMENT OF BLOOD-RELATED SIGNALS UTILIZING A FINGER HOLDER

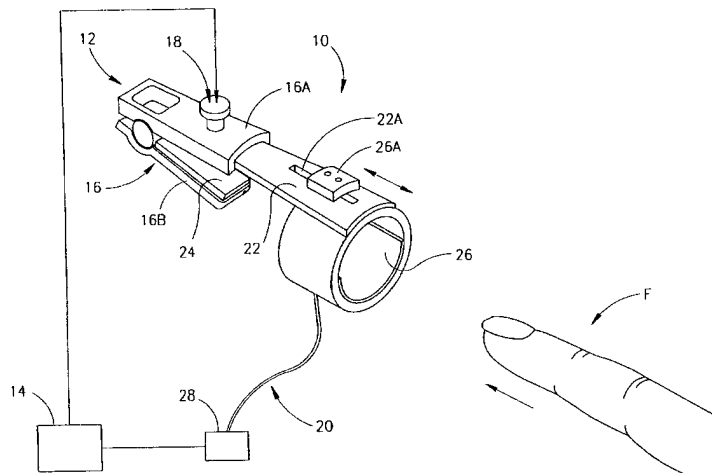

(57) Abstract: A finger holder (12) for attaching to the patient's finger (F) and an optical measurement (18) device utilizing the finger holder (12) for performing non-invasive measurements of patient's blood parameters are presented. The finger holder (12) comprises first member (16) and second member (26) spaced-apart from each other. The first member (16) is designed to secure a fingertip and to support a measuring unit (18) mounted so as to apply optical measurements to a first location of the finger (F). The second member is associated with a pressurizing assembly (26) mounted to apply desired over-systolic pressure to a second location on the patient's finger upstream of the first location with respect to a normal blood flow direction. A substantially rigid connector (22) connects the first (16) and second (26) members to each other, and is designed to engage the finger (F) along its middle phalanx and proximal interphalangeal joint, thereby preventing it from folding during the measurements, when the over-systolic pressure is applied to the finger.



WO 01/22868 A1



For two-letter codes and other abbreviations, refer to the "Guidance Notes on Codes and Abbreviations" appearing at the beginning of each regular issue of the PCT Gazette.

- 1 -

An Optical Device for Non-Invasive Measurement of Blood-related Signals utilizing a Finger Holder

FIELD OF THE INVENTION

This invention is generally in the field of non-invasive optical measurement techniques for measuring blood parameters and relates to an optical device for measuring blood-related parameters utilizing a finger holder.

5 BACKGROUND OF THE INVENTION

Non-invasive techniques for measurement of various blood parameters, such as blood oxygen saturation and the concentration of substances contained in the blood, have become very popular, since they advantageously do not require the withdrawal of a blood sample from a patient's body. Optical monitoring techniques
10 of the kind specified typically utilize the detection of light transmitted or reflected from the location on the patient's body under measurement. Most of the known techniques utilize a measurement optical device or probe, designed in a manner to be attached to the patient's finger, which includes an optical assembly for irradiating the finger with light and detecting its light response.

15 US Patent No. 5,810,723 discloses an apparatus for the non-invasive monitoring of a patient's carboxyhemoglobin level. The patient breathes oxygen to saturate his blood hemoglobin prior to detection. The apparatus utilizes a clamp with arms which hold the patient's finger: one arm supports a light emitting source and the other supports a detector. A microprocessor controls the
20 measurements and processes the detected signals.

- 2 -

US Patent 5,638,816 and its continuation, US Patent 5,860,919, disclose an apparatus for the non-invasive monitoring of blood parameters by applying pressure to the patient's finger, thus inducing an active pulse therein. The induced change of blood volume enables a better signal-to-noise ratio to be obtained.

5 US 5,782,757 discloses a measuring devices in the form of disposable, folded adhesive sensors with optics embedded therein. The probe is designed so as to fit comfortably onto a patient's fingertip.

All the conventional devices of the kind specified are aimed at measuring enhanced optical pulsatile signals caused by the changes in the volume of the blood containing medium (finger). It is known that a regular optical pulsatile signal is typically 2-3% of the total transmission. The above devices are capable of obtaining the enhanced pulsatile signal that reach 8-10% of the total light transmission intensity. This enhancement of the natural pulsatile signal is a boundary of all conventional techniques of the kind specified.

15

SUMMARY OF THE INVENTION

The present invention utilizes a non-invasive measurement technique disclosed in co-pending application PCT/IL 99/00331, assigned to the assignee of the present application, where the measured signals are not pulsatile. This is an occlusion based technique, according to which a state of blood flow cessation is created at a measurement location in a blood-perfused fleshy medium, and measurements are taken during this state. Measurements taken during the state of blood flow cessation allow for a significant increase of the blood-related signals, as compared to those taken during the state of normal blood flow. To create such a state of blood flow cessation at a measurement location in a patient's organ, over-systolic pressure is applied to the organ at a location upstream of the measurement location with respect to the direction of normal blood flow.

25

It is a major feature of the present invention to provide a finger holder for use in an optical measurement device for non-invasive measurements of patient's

- 3 -

blood parameters capable of providing the desired substantially stationary position of the finger during measurements, when over-systolic pressure is applied to the finger.

It is a further feature of the present invention to provide such a finger holder
5 whose dimensions are adjustable to the finger of a specific patient.

The finger holder according to the invention comprises a first member constructed for securing a fingertip and for supporting a measuring unit so as to apply measurements to a first location of the finger, and a second member associated with a pressurizing assembly for applying pressure to a second location
10 of the finger spaced-apart from the first location. The first and second members are coupled to each other through a substantially rigid connector engaging the finger along its middle phalanx and proximal interphalangeal joint.

The provision of the rigid connector is associated with the following. The occlusion-based measurements are non-volumetric, the changes in volume of blood
15 in the finger portion under measurements being undesirable for such measurements. However, it is a natural tendency of the finger under pressure to fold at the proximal interphalangeal joint, thereby causing undesirable changes in blood volume. By providing a substantially rigid support for the finger at the region of the middle phalanx during measurement, such undesirable folding can be avoided.

20 The measuring unit and the pressurizing assembly are connectable to a control unit, which operates them and analyzes data generated by the measuring unit indicative of a light response of the medium at the measurement location.

Generally, the measurement device may be associated with any other suitable patient's organ, such as his hand or wrist. If the patient's hand is
25 considered, the rigid connector engages the patient's arm to prevent its folding at the elbow joint. It is more practical, however, to apply the device to the patient's finger.

Preferably, the first member is designed as a clip that secures the fingertip between its legs (either one pair or two pairs of legs). The provision of two pairs of
30 legs advantageously enables to provide four-sided support for the finger, thereby

- 4 -

preventing its folding at the distal phalanx. The pressurizing assembly preferably comprises an air cushion cuff presenting the second member of the finger holder, and a pneumatic drive coupled to the cuff for operating inflation/deflation thereof.

There is thus provided according to one aspect of the invention, a finger
5 holder to be used in an optical measurement device for the non-invasive measurement of patient's blood parameters, the finger holder comprising:

- a first member for securing a fingertip and supporting an optical measuring unit mounted so as to apply measurements to a first location of the patient's finger;
- 10 - a second member associated with a pressurizing assembly mounted so as to apply desired over-systolic pressure to a second location of the finger located upstream of said first location with respect to a normal blood flow direction; and
- a substantially rigid connector between the first and second member
15 adapted to engage the finger along its middle phalanx and proximal interphalangeal joint, thereby preventing it from folding during measurements.

According to another aspect of the present invention, there is provided a device for non-invasive measurements of patient's blood parameters, the device
20 comprising an optical measuring unit, a pressurizing assembly, and a control unit, wherein the finger holder comprises:

- a first member for securing a fingertip and supporting said optical measuring unit mounted so as to apply measurements to a first location of the patient's finger;
- 25 - a second member associated with said pressurizing assembly so as to apply desired over-systolic pressure to a second location of the finger located upstream of said first location with respect to a normal blood flow direction; and
- a substantially rigid connector between the first and second member
30 adapted to engage the finger along its middle phalanx and proximal

- 5 -

intephalangeal joint, thereby preventing it from folding during measurements.

BRIEF DESCRIPTION OF THE DRAWINGS

In order to understand the invention and to see how it may be carried out in practice, a preferred embodiment will now be described, by way of non-limiting example only, with reference to the accompanying drawings, in which:

Fig. 1 is a schematic illustration of a device for non-invasive measurement of patient's blood parameters utilizing a finger holder constructed according to one embodiment of the invention; and

Fig. 2 illustrates another embodiment of the finger.

DETAILED DESCRIPTION OF A PREFERRED EMBODIMENT

Referring to Fig. 1, there is illustrated a measurement device, generally designated **10**, for the non-invasive measurement of patient's blood parameters, such as oxygen saturation, blood pressure, or the concentration of various substances, such as hemoglobin, glucose, cholesterol and other analyte concentrations. The device **10** includes a finger holder **12** to be mounted on a patient's finger **F**, and a control unit **14** coupled to the finger holder either through wires or wireless. The finger holder **12** includes a clip member **16** (constituting a first member) with a measuring unit **18** installed therein for applying measurements to a measurement location (constituting a first location), a second member in the form of an air cushion cuff **26** of a pressurizing assembly **20** for applying pressure to a second location upstream of the measurement location (with respect to the direction of normal blood flow), and a substantially rigid connector **22**.

In the present example, the clip member **16** is a two-legged member for securing the patient's finger **F** between its legs **16A** and **16B** that engage the finger **F** at both its top and bottom, respectively. A flexible thermoconductive pad **24**, made, for example, of rubber or silicone, is provided at the inner surfaces of the legs **16A** and **16B**. The pad **24** is coupled to a power source (not shown) which is

- 6 -

operated by the control unit **14** for applying appropriate, substantially low voltages, for example in the range 1V-24V to the pad **24**, enabling heating of the finger portion located between the clip legs **16A** and **16B** (i.e., the location under measurements) up to 37-38°. The heating ability of the device increases the accuracy of the non-invasively derived blood-related parameters. The substantially low voltage supply is, on the one hand, acceptable for medical devices, and, on the other hand, requires low power supply (e.g., 6-9V) that allows for using batteries, thereby rendering the entire device conveniently portable.

The measuring unit **18**, which is partly shown in the figure, does not form part of the present invention, and therefore need not be specifically illustrated and described, except to note the following. The measuring unit **18** comprises both an illumination and detection means that could be accommodated either at one side of the finger when operating in a reflection mode, or at opposite sides of the finger when operating in a transmission mode. These reflected or transmitted signals present light response of the finger to incident radiation. In the present example, the measuring unit **18** provides illumination of the finger **F** with at least two different wavelengths, and detects light transmitted therethrough. Data indicative of the detected light (light response) is transmitted to the control unit **14** (typically through analog-to-digital converter and data processing unit) that includes a processor operated by a suitable software model for determining and analyzing the time dependency of the detected light for each incident wavelength to determine a relation between the time variations corresponding to different wavelengths, and to calculate the desired parameter of blood based on this relation.

As indicated above, the present invention utilizes the measurement of blood-related signals at a state of blood flow cessation at the measurement location. To this end, the pressurizing assembly **20** is capable of applying over-systolic pressure, e.g., 270-300mmHg (generally, adjustable for each specific patient) at the second location upstream of the measuring unit **18** with respect to the direction of normal blood flow. The pressurizing assembly **20** includes the air cushion cuff **26**

- 7 -

in the form of a ring wrapping the respective location on the patient's finger **F**, and a pneumatic drive **28** coupled to the cuff **26** and to the control unit **14**.

Hence, the drive **28**, whilst being actuated by the control unit **14**, operates to apply over-systolic pressure to the finger portion (second location on the finger) underneath the cuff-ring **26**. The application of pressure is maintained for a period
5 of time so as not to cause irreversible changes in the finger, e.g., 4 seconds (generally, lasting from one second to one minute and more). Then, the control unit operates the drive **28** to release the pressure. The effective measurements, i.e., the results which have to be analyzed, are those taken at the state of blood flow
10 cessation, as will be described more specifically further below.

As clearly seen in Fig. 1, the connector **22** is shaped like a plate, and is formed with an elongated slot **22A**. The cuff-ring **26** is formed with a projection **26A** installed in the slot **22A** for reciprocating sliding movement along its axis. This enables to adjust the length of the finger holder **12** to that of the finger of a
15 specific patient. The rigid plate-like connector **22** engages the finger along its middle phalanx, preventing its folding at the proximal interphalangeal joint, thereby avoiding undesirable changes in blood volume.

The operational mode of the device **10** may be such that the control unit **14** actuates the measuring unit **18** for performing continuous measurements starting
20 prior to the application of over-systolic pressure. In this case, only those signals which are associated with the state of blood flow cessation are taken into consideration. Measurements taken during the time period prior to the establishment of this state should be disregarded, due to the unavoidable influence of motional and/or other artifacts causing non-monotonic fluctuations of the light
25 transmission. According to an alternative operational mode of the device **10**, the control unit **14** actuates the measuring unit **18** approximately 0.5 sec after the application of the over-systolic pressure. During the time period corresponding to the existence of the state of blood flow cessation, relative light transmission of blood is observed, which reaches its maximum and may last for about 2-5.5 sec
30 (generally, from one second to one minute and more).

To obtain meaningful results, either one of at least two timely separated measurement sessions should be considered, at least one of them occurring during the state of blood flow cessation, or a single long continuous measurement session is considered starting after the establishment of the state of blood flow cessation.

5 During the first measurement session, the control unit **14** operates to maintain the cuff **26** in its squeezed position. The control unit **14** then operates the pressurizing assembly **20** to release the over-systolic pressure. The squeezing action of the cuff **26** is ceased, and after a short delay of about 0.5sec, the blood flow gradually increases during approximately 5sec. Then, the control unit **14** actuates the second

10 measurement session at a state of the transitional blood flow. The illumination unit continues to illuminate the finger, but squeezing is halted. The detection unit, being synchronized by the control unit **14**, detects the light response of the finger.

In other words, the control unit **14** selectively operates the measuring unit **18** and the pressurizing assembly **20**, and analyzes data coming from the measuring

15 unit. The construction and operation of the control unit do not form part of the present invention, and may be of any known kind capable of running an appropriate software model.

Reference is made to Fig. 2 illustrating a finger holder **112** having somewhat different construction of its clip member **116**, as compared to that of the finger

20 holder **12**. The clip member **116** is a four-leg member, wherein two opposite legs **116A** and **116B** engage the finger at its top and bottom thereof, and the other opposite legs **116C** and **116D** engage the opposite sides of the finger, respectively. Such four-sided support of the fingertip prevents its folding at the distal phalanx, thereby avoiding undesirable blood volume changes..

25 It should be noted that the connector **22** may be located at either side of the patient's finger. Alternatively, a pair of such connectors can be used located at opposite sides of the finger. Additionally, the processor may be accommodated within the cuff, and the wires, if any, connecting the processor to the output circuit of the measuring unit, may pass through the rigid connector.

– 9 –

Those skilled in the art will readily appreciate that various modifications and changes may be applied to the preferred embodiments of the invention as herein before exemplified without departing from its scope defined in and by the appended claims. For example, the cuff **26** may be a band formed with Velcro-like
5 fasteners, so as to form a ring wrapping the patient's finger when in the operational position of the device. Alternatively, a band composed of a set of various air cushions pressuring on the finger. In this case, the pressurizing assembly fits itself to each finger size without any additional adjusting means.

- 10 -

CLAIMS:

1. A finger holder to be used in an optical measurement device for non-invasive measurement of patient's blood parameters, the finger holder comprising:
 - 5 - a first member for securing a fingertip and supporting an optical measuring unit mounted so as to apply measurements to a first location of the patient's finger;
 - a second member associated with a pressurizing assembly mounted so as to apply desired over-systolic pressure to a second location of the finger upstream of said first location with respect to a normal blood flow
10 direction; and
 - a substantially rigid connector between the first and second members adapted to engage the finger along its middle phalanx and proximal interphalangeal joint, thereby preventing it from folding during the
15 measurements.
2. The finger holder according to Claim 1, wherein said first member is a clip securing the fingertip between its legs.
3. The finger holder according to Claim 1, wherein said second member is an air cushion cuff-ring of the pressurizing assembly wrapping said second location,
20 the pressurizing assembly also comprising a pneumatic drive coupled to the cuff-ring so as to apply said over-systolic pressure to said second location.
4. The device according to Claim 1, wherein said connector is shaped like a plate and has an elongated slot extending the finger's axis, said second member having a projection installed in the slot for sliding movement along its axis.
- 25 5. The finger holder according to Claim 3, wherein said cuff-ring is a band having Velcro-like fasteners so as to form the ring on the patient's finger.
6. The finger holder according to Claim 2, wherein said clip member has two clamping legs for securing the finger therebetween in a manner allowing the optical measurements.

– 11 –

7. The finger holder according to Claim 1, wherein said first member is provided at inner surface thereof facing the finger with a flexible member for wrapping the first location of the finger.
8. The finger holder according to Claim 7, wherein said flexible member is made of a thermoconductive material for heating said first location under measurements up to desired temperature.
9. The finger holder according to Claim 8, wherein said desired temperature is approximately 37°-38°.
10. The finger holder according to Claim 8, wherein the flexible thermoconductive material is rubber.
11. The finger holder according to Claim 8, wherein the flexible thermoconductive material is silicone.
12. The finger holder according to Claim 1, wherein said over-systolic pressure is such as to create a state of substantial blood flow cessation at said first location.
13. The finger holder according to Claim 12, wherein said over-systolic pressure is in the range 270-300mmHg.
14. A device for non-invasive measurements of patient's blood parameters, the device comprising an optical measuring unit, a pressurizing assembly, and a control unit, wherein the finger holder comprises:
- a first member for securing a fingertip and supporting said optical measuring unit mounted so as to apply measurements to a first location of the patient's finger;
 - a second member associated with said pressurizing assembly so as to apply desired over-systolic pressure to a second location of the finger located upstream of said first location with respect to a normal blood flow direction; and
 - a substantially rigid connector between the first and second member adapted to engage the finger along its middle phalanx and proximal

– 12 –

intephalangeal joint, thereby preventing it from folding during measurements.

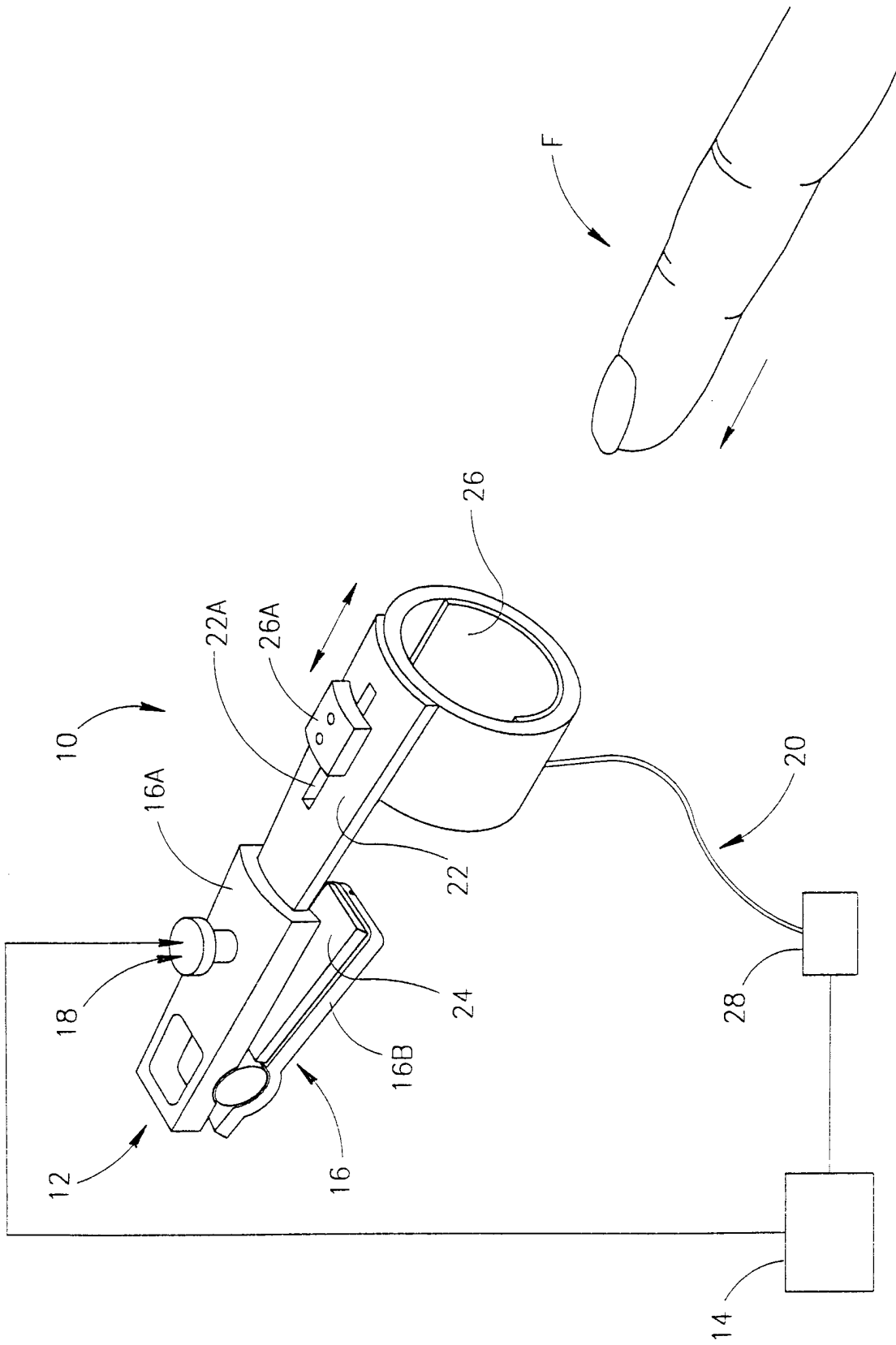

FIG.1

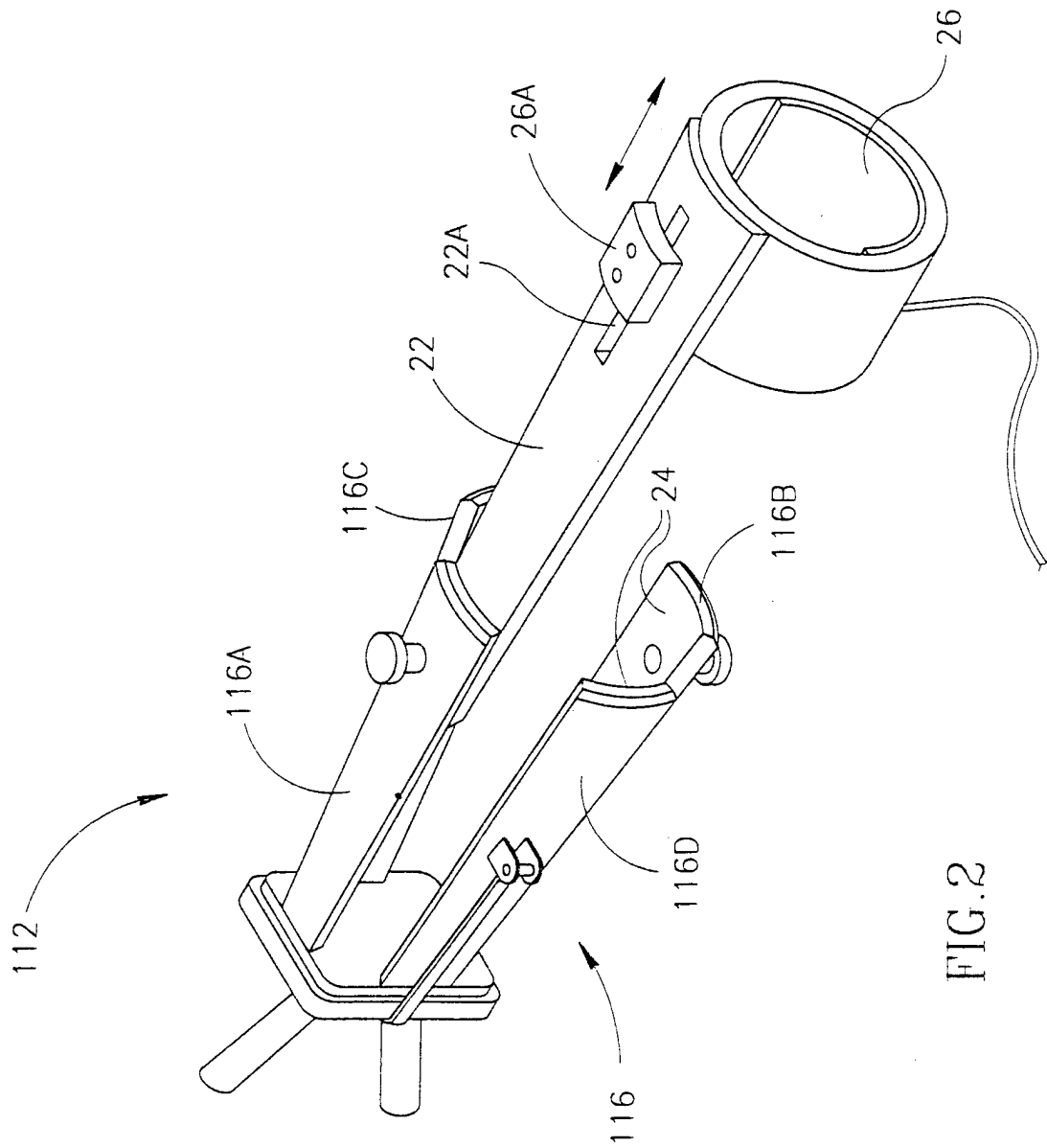

FIG. 2

INTERNATIONAL SEARCH REPORT

International Application No

PCT/IL 00/00603

A. CLASSIFICATION OF SUBJECT MATTER
 IPC 7 A61B5/00 A61B5/022

According to International Patent Classification (IPC) or to both national classification and IPC

B. FIELDS SEARCHED

Minimum documentation searched (classification system followed by classification symbols)

IPC 7 A61B

Documentation searched other than minimum documentation to the extent that such documents are included in the fields searched

Electronic data base consulted during the international search (name of data base and, where practical, search terms used)

EPO-Internal

C. DOCUMENTS CONSIDERED TO BE RELEVANT

Category °	Citation of document, with indication, where appropriate, of the relevant passages	Relevant to claim No.
X	US 4 927 264 A (SHIGA & AL) 22 May 1990 (1990-05-22) column 4, line 15 -column 5, line 28 -----	1, 3, 12, 14
A, P	WO 99 63884 A (SCHNALL) 16 December 1999 (1999-12-16) page 19, line 11 -page 21, line 20 -----	1, 2, 5-11, 14
A	FR 2 524 792 A (FENESTRAZ) 14 October 1983 (1983-10-14) page 8, line 20 -page 9, line 3 -----	1, 2, 6, 14
A	US 5 833 602 A (OSEMWOTA) 10 November 1998 (1998-11-10) column 4, line 38 - line 47 column 7, line 57 -column 8, line 23 -----	1, 3, 12-14

Further documents are listed in the continuation of box C.

Patent family members are listed in annex.

° Special categories of cited documents :

- *A* document defining the general state of the art which is not considered to be of particular relevance
- *E* earlier document but published on or after the international filing date
- *L* document which may throw doubts on priority claim(s) or which is cited to establish the publication date of another citation or other special reason (as specified)
- *O* document referring to an oral disclosure, use, exhibition or other means
- *P* document published prior to the international filing date but later than the priority date claimed

- *T* later document published after the international filing date or priority date and not in conflict with the application but cited to understand the principle or theory underlying the invention
- *X* document of particular relevance; the claimed invention cannot be considered novel or cannot be considered to involve an inventive step when the document is taken alone
- *Y* document of particular relevance; the claimed invention cannot be considered to involve an inventive step when the document is combined with one or more other such documents, such combination being obvious to a person skilled in the art.
- * & * document member of the same patent family

Date of the actual completion of the international search

26 January 2001

Date of mailing of the international search report

06/02/2001

Name and mailing address of the ISA

European Patent Office, P.B. 5818 Patentlaan 2
 NL - 2280 HV Rijswijk
 Tel. (+31-70) 340-2040, Tx. 31 651 epo nl,
 Fax: (+31-70) 340-3016

Authorized officer

Lemercier, D

INTERNATIONAL SEARCH REPORT

Information on patent family members

International Application No

PCT/IL 00/00603

Patent document cited in search report	Publication date	Patent family member(s)	Publication date
US 4927264 A	22-05-1990	JP 2551059 B JP 1146525 A JP 1146526 A	06-11-1996 08-06-1989 08-06-1989
WO 9963884 A	16-12-1999	AU 4161699 A	30-12-1999
FR 2524792 A	14-10-1983	NONE	
US 5833602 A	10-11-1998	NONE	

专利名称(译)	一种利用手指支架无创测量血液相关信号的光学装置		
公开(公告)号	EP1217941A1	公开(公告)日	2002-07-03
申请号	EP2000964598	申请日	2000-09-27
申请(专利权)人(译)	ORSENSE LTD.		
当前申请(专利权)人(译)	ORSENSE LTD.		
[标]发明人	FINAROV ALEXANDER KLEINMAN YOSSIE FINE ILYA		
发明人	FINAROV, ALEXANDER KLEINMAN, YOSSIE FINE, ILYA		
IPC分类号	A61B5/00 A61B5/022 A61B5/145 A61B5/1455		
CPC分类号	A61B5/6826 A61B5/02241 A61B5/14552 A61B5/6838		
优先权	09/407390 1999-09-28 US		
其他公开文献	EP1217941B1		
外部链接	Espacenet		

摘要(译)

提出了用于附接到患者手指 (F) 的手指保持器 (12) 和利用手指保持器 (12) 用于执行患者血液参数的非侵入式测量的光学测量 (18) 装置。手指保持器 (12) 包括彼此间隔开的第一构件 (16) 和第二构件 (26)。第一构件 (16) 设计成固定指尖并支撑安装的测量单元 (18)，以便将光学测量值应用于手指 (F) 的第一位置。第二构件与加压组件 (26) 相关联，加压组件 (26) 安装成将期望的过度收缩压力相对于正常血流方向施加到第一位置上游的患者手指上的第二位置。基本上刚性的连接器 (22) 将第一 (16) 和第二 (26) 构件彼此连接，并设计成沿着其中节指骨和近端指间接头接合手指 (F)，从而防止其在测量期间折叠当过度收缩压施加到手指上时。