



(11) **EP 2 922 468 B1**

(12) **EUROPEAN PATENT SPECIFICATION**

(45) Date of publication and mention of the grant of the patent:
08.06.2016 Bulletin 2016/23

(51) Int Cl.:
A61B 5/1455 ^(2006.01) **A61B 5/00** ^(2006.01)
A61B 5/022 ^(2006.01)

(21) Application number: **14708642.5**

(86) International application number:
PCT/IB2014/000139

(22) Date of filing: **10.02.2014**

(87) International publication number:
WO 2014/125355 (21.08.2014 Gazette 2014/34)

(54) **NON-INVASIVE BLOOD ANALYSIS**

NICHTINVASIVE BLUTANALYSE

ANALYSE DE SANG NON INVASIVE

(84) Designated Contracting States:
AL AT BE BG CH CY CZ DE DK EE ES FI FR GB GR HR HU IE IS IT LI LT LU LV MC MK MT NL NO PL PT RO RS SE SI SK SM TR

(30) Priority: **13.02.2013 GB 201302548**
23.09.2013 GB 201316914
23.09.2013 GB 201316915

(43) Date of publication of application:
30.09.2015 Bulletin 2015/40

(73) Proprietor: **Leman Micro Devices SA**
1015 Lausanne (CH)

(72) Inventors:
• **ELLIOTT, Christopher**
CH-1025 St. Sulpice (CH)
• **JONES, Mark-Eric**
CH-1304 Cossonay-Ville (CH)
• **VARSHNEY, Arushi**
CH-1015 Lausanne (CH)
• **RUEGG, Matthieu**
CH-1015 Lausanne (CH)

(74) Representative: **Phillips & Leigh**
5 Pemberton Row
London EC4A 3BA (GB)

(56) References cited:
WO-A2-2013/001265 US-A- 4 882 492

EP 2 922 468 B1

Note: Within nine months of the publication of the mention of the grant of the European patent in the European Patent Bulletin, any person may give notice to the European Patent Office of opposition to that patent, in accordance with the Implementing Regulations. Notice of opposition shall not be deemed to have been filed until the opposition fee has been paid. (Art. 99(1) European Patent Convention).

Description

Field of the invention

[0001] The present invention relates to a personal hand-held monitor (PHHM) adapted to measure the concentration of an analyte in blood.

Background to the invention

[0002] There are many circumstances in which it is desirable to measure the concentration of an analyte in blood. One of the most important is the measurement of blood glucose concentration, of crucial importance to the management of diabetes. It is estimated by Danaei et al. ("National, regional, and global trends in fasting plasma glucose and diabetes prevalence since 1980: systematic analysis of health examination surveys and epidemiological studies with 370 country-years and 2.7 million participants", *Lancet*, 2011, 378(9785):31-40) that 370 million people in the world suffer from diabetes and the WHO predicts that diabetes will be the 7th leading cause of death in 2030 ("Global status report on non-communicable diseases 2010", WHO 2011). At present, the only accurate and inexpensive way for diabetics to measure their blood glucose concentration is by taking a blood sample, usually by pricking a finger, and placing a drop of blood on a test strip. A measurement of the change of colour of the strip or a measurement of a redox reaction on the strip after application of the blood sample provides an indication of the blood glucose concentration.

[0003] Inexpensive automated equipment exists to estimate the change in colour or the electrochemical reaction but there is no consumer equipment capable of making the measurement without taking a blood sample and many diabetics have to do this several times per day.

[0004] Other analytes such as alcohol, haemoglobin, creatinine, cholesterol, stimulants or other drugs, including illegal or otherwise forbidden substances, are also important and again there is no accurate, reliable and inexpensive way of estimating their concentration non-invasively.

[0005] In principle, absorption spectroscopy would be a good method for estimating the concentration of an analyte but this is difficult *in vivo* if the contribution to the absorption from the analyte is small compared to the absorption by other materials in the blood and tissue, especially if the analyte has few or no narrow absorption bands in the useable near infra-red (NIR) and/or if those bands are overlapping with those of water, which is the predominant component of blood and tissue. For example, Klonoff ("Non-invasive blood glucose monitoring", *Diabetes Care*, 20, 3, 435-437 1997) states: "*Glucose is responsible for <0.1% of NIR absorbed by the body. Water, fat, skin, muscle and bone account for the vast majority of NIR absorption. Perturbations in the amounts of these substances can alter NIR absorption and thus invalidate the calibration formula for correlating light ab-*

sorption with blood glucose concentrations ...".

[0006] Even if this could be overcome, the measurement of the specific absorption would require a precise spectrometer that is not easily made inexpensively and reliably.

[0007] US Patent 4,882,492 in 1989 disclosed an invention employing "*non-dispersive correlation infra-red spectroscopy*". According to this disclosure, broad spectrum NIR light is transmitted through or scattered by a body part. The emergent light is split into two beams. One beam passes through a filter consisting of a solution of the analyte and the other through a neutral density filter. The analyte filter absorbs from the first beam substantially all of the light in the spectral absorption bands of the analyte. The neutral density filter reduces the power of the second beam to be similar to the power of the first beam. Any difference between the powers of the light in the two beams arises solely from the amount of light absorbed by the analyte in the body part.

[0008] The US Patent alleges that spectral specificity is achieved without the need for a dispersive element (a spectrometer) but this depends crucially on the balance between the two beams and the exact characteristics of the neutral density filter. It also does not distinguish analyte in the blood from analyte in the surface layers of the tissue. In practice, this is likely to prevent the device ever being reliable or accurate.

[0009] Fine (Chapter 9 of Handbook of optical sensing of glucose in biological fluids and tissues, 2009) describes a technique for estimating glucose concentration by the change in the optical scattering of aggregated red blood cells. It uses an analogy with a pulse oximeter and correlates the scattered signal with the variation of area of the artery as the heart beats, thus making the signal preferentially sensitive to the glucose in the arterial blood. However, Fine concludes that this technique is ineffective, in part because the change in arterial area is relatively small.

[0010] WO 2013/001265 discloses significant improvements on US Patent 4,882,492. Claim 25 of WO 2013/001265 relates a personal hand-held monitor (PHHM) comprising a signal acquisition device for acquiring signals which can be used to derive a measurement of a parameter related to the health of the user, the signal acquisition device being integrated with a personal hand-held computing device (PHHCD), wherein the signal acquisition device comprises a blood photosensor having a photo-emitter for transmitting light to a body part of a user, a photo-detector for detecting light transmitted through or scattered by the body part and an optical cell, containing an analyte to be detected, through which light transmitted through or scattered by the body part passes before it reaches the photo-detector, wherein the processor of the PHHM is adapted to process signals obtained from the photo-detector in the presence of the body part and in the absence of the body part to provide a measurement of the concentration of the analyte in the user's blood. WO 2013/001265 also discloses using the

principle of two beams, one of which passes through a cell containing the analyte and compares the power in each beam.

[0011] Figures 1 and 2 in the attached drawings, which are identical to Figures 9 and 11 of WO 2013/001265, show two arrangements of blood photosensors to be used in the PHHM claimed in claim 25 of WO 2013/001265, which may be incorporated into a PHHCD, or may be connected to a PHHCD or may be constructed as a stand-alone device with its own user interface, power supply and other electronic and mechanical components.

[0012] As shown in Figure 1, a photo-emitter (81) transmits a beam of light that passes through a filter (82) to select the spectral band of the light to be used. The spectral band is chosen to allow inexpensive components and materials to be used whilst maximising the sensitivity and discrimination with respect to the analyte. The beam is collimated by a lens (83) to shine through a body part, such as a finger (84). A beam splitter (85) divides the beam between a non-analyte cell (86) and analyte cell (87). Photo-detectors (88) measure the intensity of the beam after it has passed through each cell. A differential amplifier may be used to amplify the difference in signals from the two photo-detectors.

[0013] Figure 2 shows another arrangement in which the photo-emitter and photo-detector are on the same side of a body part, the photo-detector being sensitive to the light scattered back from the body part. A moving mirror (101) reflects light sequentially to each of two fixed mirrors (102) and hence to the non-analyte cell (86) or analyte cell. The photo-detector (108) measures the intensity of the beam that has passed the cells.

[0014] In each of these arrangements, the difference between the intensity when the beam of light has passed through the non-analyte cell and through the analyte cell is a measure of the amount of absorption by the analyte within the body part.

[0015] The invention disclosed in WO 2013/001265 goes some way towards the goal of a sensor that is non-invasive, inexpensive, accurate and reliable. However, it is not specific to the analyte contained in blood because the signal is also affected by analyte in the surrounding tissue. Further improvements are also desirable to reduce the cost of implementation and to improve accuracy.

The Present Invention

[0016] The present invention greatly improves on the performance of the PHHM of claim 25 of WO 2013/001265. It exploits more effectively a second degree of correlation to improve specificity.

[0017] According to the present invention there is provided a personal hand-held monitor as defined in claim 1. The processor of the PHHM of the invention is adapted to determine the pulse of the user and to correlate the signals obtained from the photosensor with the user's pulse in providing a measurement of the analyte in the

user's blood. The processor of the PHHM may be adapted to analyse the signals received from the blood photosensor to determine the pulse of the user. Alternatively, the PHHM may include an electrical sensor comprising at least a first and a second electrode which are electrically isolated from one another and which are arranged to be contacted by two separate parts of the user's body, such as a finger on one hand and a finger on the other hand, and the processor of the PHHM is adapted to analyse the signals from the electrical sensor to determine the pulse of the user. Such an electrical sensor is disclosed in WO 2013/001265.

[0018] According to a second aspect, there is provided a personal hand-held monitor (PHHM) comprising a signal acquisition device for acquiring signals which can be used to derive a measurement of a parameter related to the health of the user, wherein the signal acquisition device comprises a blood photosensor having one or more photo-emitters for transmitting light to a body part of a user, one or more photo-detectors for detecting light transmitted through or scattered by the body part and two or more optical cells, at least one of which contains an analyte to be detected or which mimics the absorption spectrum of the analyte to be detected, through which the light that has been or will be transmitted through or scattered by the body part passes before it reaches the or each photo-detector, wherein the processor of the PHHM is adapted to process the signals received from the or each photo-detector to calculate the difference in intensity of light which has passed through the or each analyte cell and light which has passed through the or each non-analyte cell, to determine the pulse of the user and to correlate the signals obtained from the photosensor in the presence of the body part and in the absence of the body part with the user's pulse to provide a measurement of the concentration of the analyte in the user's blood.

[0019] In this aspect the processor of the PHHM may be adapted to analyse the signals from the blood photosensor to determine the pulse or the PHHM may include an electrical sensor as referred to above.

[0020] Preferably, the PHHM of the second aspect is self-contained and includes a processor, display and control, communications and storage means to provide a measurement of the concentration of the analyte in the user's blood. Alternatively, the signal acquisition device is integrated with a personal hand-held computing device (PHHCD).

[0021] Preferably, in order further to improve the selectivity for the concentration of the analyte in blood, the processor of the PHHM is adapted to measure the intensity of a beam of light for use in photoplethysmography (PPG) to identify the time at which an artery in the body part dilates due to systole. The change in absorption at this point is a consequence solely of the additional amount of blood in the body part. Figure 5, which illustrates this relationship, shows a graph derived from a mathematical model of the performance of this preferred

feature. The horizontal axis is the concentration of the analyte, in this case illustrated as glucose, in the blood and the vertical axis is the change in difference of signal between the two cells when the artery is occluded and when the artery is patent, using a realistic value for the intensity of light from the photo-emitter and the scattering within the body part.

[0022] This change in difference of signal is proportional to the total amount of analyte, such as glucose, in the blood within the field of view of the PHHM. In Figure 5, typical values for arterial size have been assumed. In order to convert this to a concentration, the PHHM is also adapted to estimate the volume of that additional blood from the intensity change of the beam of light.

[0023] Preferably, each photo-emitter of the PHHM is a thermal emitter consisting of an electrically heated element, the temperature of which is stabilised by means of a feedback loop in which the temperature of the element is found by measuring the electrical resistance of the element and the current through the element adjusted so as to maintain a constant resistance. Preferably, the processing means of the PHHM, which may be part of a PHHCD, is adapted to carry out the analysis and control to implement the feedback loop.

[0024] The light from the photo-emitter may be focused by two curved mirrors onto the cells, after each of which is located a shutter. The processing means is adapted to operate the shutters to select through which shutter the light that illuminates the body part has passed, after which the light is detected by the or each photo-detector. The or each shutter may be mechanical or electro-optical devices such as liquid crystals.

[0025] The light from the or each photo-emitter may be transmitted to the body part by means of fibre-optics so as to allow the optical and electrical components to be conveniently remote from the body part. The light penetrates the body part, is scattered or transmitted by the tissue and blood vessels within the body part and may be then collected by one or more further fibre optic devices.

[0026] It is apparent that the cells and the elements used to direct the light through them may be located before or after the light passes through or is scattered by the body part.

[0027] The cells may comprise areas on a rotating disc interposed between the or each photo-emitter and the or each photo-detector. Some areas of the rotating disc will be coated with analyte or adapted to mimic the absorption spectrum of the analyte and other areas may be uncoated or may be coated by a material with a different absorption spectrum from that of the analyte. In this case, the processor of the PHHM is adapted to co-ordinate the signals received from the or each photo-detector with the rotational position of the disc. This allows the PHHM to employ a single photo-detector and to reduce the complexity of the optical parts, but at the expense of introducing a moving part.

[0028] The non-analyte and analyte cells as illustrated

in Figures 1 and 2 may be replaced by multiple such cells so as to minimise the errors caused if the light is not perfectly collimated and takes different paths through or to and from the body part. Multiple photo-detectors may be employed or the light through more than one non-analyte cell may be collected by one photo-detector and the light through more than one analyte cell be similarly collected.

[0029] WO 2013/001265 discloses a PHHM which is adapted to differentiate between signals when the body part is present from signals when it is not. It also discloses a way in which the properties of an artery during the pulse cycle may be exploited. It is well-known that the luminal area of an artery varies as a function of the pressure difference between the arterial blood pressure and the pressure imposed on the artery wall by the surrounding tissue. This is the principle of the Riva-Rocci sphygmomanometer. This is the basis of the disclosure in WO 2013/001265. In addition, the magnitude of the change of luminal area is greatest when the imposed pressure is close to or slightly greater than the diastolic blood pressure in the artery.

[0030] The PHHM of the present invention includes a means for applying pressure to the body part in the region of an artery, a means for measuring the change in luminal area with each pulse and a means for adjusting the imposed pressure so as to approximate to diastolic blood pressure and thus maximise the change in luminal area. The processor of the PHHM is adapted to detect the difference between the signals from the photosensor when the artery is patent (*i.e.* at systole when the artery is expanded because the arterial pressure exceeds the imposed pressure) and those when it is occluded (*i.e.* at diastole when the artery is collapsed because the arterial pressure is less than the imposed pressure).

[0031] The signal analysis of the PHHM of this preferred aspect of the invention is thus coherent with the user's pulse.

[0032] According to a third aspect there is provided a personal hand-held monitor (PHHM) comprising a signal acquisition device for acquiring signals which can be used to derive a measurement of a parameter related to the health of the user, wherein the signal acquisition device comprises a blood photosensor having one or more photo-emitters for transmitting light to a body part of a user, one or more photo-detectors for detecting light transmitted through or scattered by the body part and two or more optical cells, at least one of which contains an analyte to be detected or which mimics the absorption spectrum of the analyte to be detected, through which the light that has been or will be transmitted through or scattered by the body part passes before it reaches the or each photo-detector, wherein the processor of the PHHM is adapted to process the signals received from the or each photo-detector to calculate the difference in intensity of light which has passed through the or each analyte cell and light which has passed through the or each non-analyte cell, to determine the pulse of the user

and to correlate the signals obtained from the photosensor with the pulse of the user, wherein the PHHM is adapted to apply pressure to the body part or to have pressure applied to it by the body part so that, in use, an artery in the body part changes from occluded to patent during each pulse and the processor of the PHHM is adapted to derive a measurement of the change in the luminal area of the artery during each pulse and to correlate the signals received from the blood photosensor with the pulse and the change in the luminal area of the artery to provide a measurement of the concentration of the analyte in the arterial blood.

[0033] The means for applying an external pressure to the body part and means for detecting the change in luminal area on each pulse may comprise optical sensors as described in WO 2013/001265.

[0034] Preferably the processing means of the PHHM is further adapted to provide audible or visual feedback to the user so that the external pressure may be applied and maintained by the actions of the user, either by pressing the PHHM against the body part or the body part against the PHHM.

[0035] This preferred feature of the invention has the benefit of simplifying the way of making measurements but also ensures that the difference between the signals that is measured depends effectively only on the quantity of analyte in the arterial blood and not on that in the surrounding tissue.

[0036] Preferably, the or each photo-detector is an In-GaAs photo-detector. These offer improved signal to noise ratio over the photo-detectors proposed previously.

[0037] The signal obtained from the difference between the signals obtained from the non-analyte and analyte cells, or from the different windows of the rotating disc, must be normalised to estimate the concentration of analyte in the arterial blood. This normalisation may be non-linear. Preferably, the normalisation takes account of the amplitude of the signal from each cell, both with the artery patent and with it occluded, and the amplitude of the signal when the body part is absent. Preferably, it further takes account of the amplitude of the signal indicative of the luminal area to find the concentration of the analyte rather than the total quantity within the field of view of the sensor. Preferably, the processor of the PHHM is adapted to process signals received from the photosensor when the or each photo-emitter is turned off or the light emitted therefrom is completely blocked to compensate signals received when the light from the photo-emitter illuminates the body part for ambient light.

[0038] The present invention is described below with reference to the accompanying drawings by way of example only. The invention is not limited to the embodiments shown in the accompanying drawings. The scope of the invention is defined in the accompanying claims.

[0039] In the accompanying drawings:

Figures 1 and 2 show arrangements for an optical sensor to be used in a PHHM as disclosed in WO

2103/001265;

Figure 3 shows an arrangement of an optical sensor using a rotating disc;

Figure 4 shows an arrangement of an optical sensor using a thermal emitter; and

Figure 5 shows a graph derived from a mathematical model of the performance of an embodiment of the invention.

[0040] In one aspect of the PHHM of the present invention, as shown in Figure 3, a rotating disc (31) is interposed between a thermal emitter (30) and the photo-detector (33).

[0041] The light is carried by fibre-optics (32). Alternating areas of the rotating disc are coated with the analyte and the others are left clear or coated with a material with a different absorption spectrum from that of the analyte. The instantaneous orientation of the rotating disc (31) is communicated to the processor of the PHHM together with the signal from the photo-detector. The processor is adapted to detect the amplitude of the signal from the photo-detector coherently with the rotation of the disc.

[0042] In another aspect, the non-analyte and analyte cells as illustrated in Figures 1 and 2 are replaced by multiple such cells so as to minimise the errors caused if the light is not perfectly collimated and takes different paths through the body part. Multiple photosensors may be employed or the light through more than one non-analyte cell may be collected by one photosensor and the light through more than one analyte cell be similarly collected.

[0043] In another aspect, shown in Figure 4, light from a thermal emitter (41) is focused by two curved mirrors (42) onto the cells (43 and 44), after each of which is located a shutter (45). The processing means is adapted to operate the shutters to select through which shutter the light that illuminates the body part (46) has passed, after which the light is detected by the photo-detector (47). The shutter(s) may be mechanical or electro-optical devices such as liquid crystals.

Claims

1. A personal hand-held monitor (PHHM) comprising a signal acquisition device for acquiring signals which can be used to derive a measurement of a parameter related to the health of the user, wherein the signal acquisition device comprises a blood photosensor having one or more photo-emitters (81) for transmitting light to a body part of a user, one or more photo-detectors (88; 108) for detecting light transmitted through or scattered by the body part and two or more optical cells (86; 87), at least one of which contains an analyte to be detected or which mimics the absorption spectrum of the analyte to be detected, through which the light that has been or will be transmitted through or scattered by the body part passes

- before it reaches the or each photo-detector, wherein the processor of the PHHM is adapted to process the signals received from the or each photo-detector to calculate the difference in intensity of light which has passed through the or each analyte cell and light which has passed through the or each non-analyte cell, to determine the pulse of the user and to correlate the signals obtained from the photosensor with the pulse of the user, wherein the PHHM is adapted to apply pressure to the body part or to have pressure applied to it by the body part so that, in use, an artery in the body part changes from occluded to patent during each pulse and the processor of the PHHM is adapted to derive a measurement of the change in the luminal area of the artery during each pulse and to correlate the signals received from the blood photosensor with the pulse and the change in the luminal area of the artery to provide a measurement of the concentration of the analyte in the arterial blood.
2. The PHHM of claim 1, wherein the PHHM is adapted to be pressed against the body part or to have the body part pressed against it by a user to vary the luminal area of the artery.
 3. The PHHM of claim 2, wherein the processor of the PHHM is adapted to provide visual and/or audible instructions to the user to vary the pressure applied to or by the body part so that the change in luminal area of the artery with each pulse is maximised.
 4. The PHHM of any one of claims 1 to 3, wherein the or each photo-emitter is a thermal emitter.
 5. The PHHM of claim 4, wherein the temperature of each photo-emitter is controlled by means of feedback that regulates the current through or voltage across the photo-emitter.
 6. The PHHM of any one of claims 1 to 5, wherein the light is transmitted to and/or from the body part by means of fibre-optics.
 7. The PHHM of any one of claims 1 to 6, including means for attenuating partially or completely the light emitted by the or each photo-emitter.
 8. The PHHM of any one of claims 1 to 7, wherein the processor of the PHHM is adapted to normalise the calculated difference between the signals from the photosensor by taking account of the measured value of each of those signals, the signal from the photo-detector when the photo-emitter is completely attenuated, similar signals from the photosensor when the body part is not present and any signals derived from the means used to detect the change in luminal area of the artery.
 9. The PHHM of any one of claims 1 to 8, wherein the cells comprise a rotating disc, one or more parts of which are coated with or carry in solution the analyte or which mimic the absorption spectrum of the analyte and the other parts of which do not.
 10. The PHHM of any one of claims 1 to 9, wherein one or more shutters are used to select the path of the light through the blood photosensor.
 11. The PHHM of claim 10 wherein the optical shutters are electro-optical devices.
 12. The PHHM of any one of claims 1 to 11, wherein the or each photo-detector is formed of InGaAs.
 13. The PHHM of any one of claims 1 to 12, wherein the analyte is glucose, ethanol, haemoglobin, creatinine or cholesterol.
 14. The PHHM of any one of claims 1 to 12, wherein the analyte is an illegal or otherwise forbidden drug or stimulant.
 15. The PHHM of any one of claims 1 to 14, wherein the optical system is integrated.
 16. The PHHM of any one of claims 1 to 15, which includes an electrical sensor comprising at least a first and a second electrode which are electrically isolated from one another and which are arranged to be contacted by two separate parts of the user's body, such as a finger on one hand and a finger on the other hand, and the processor of the PHHM is adapted to analyse the signals from the electrical sensor to determine the pulse of the user.
 17. The PHHM of any one of claims 1 to 16, which is self-contained and includes a processor, display and control, communications and storage means to provide a measurement of the concentration of the analyte in the user's blood.
 18. The PHHM of any one of claims 1 to 17, wherein the signal acquisition device is integrated with a personal hand-held computing device (PHHCD).
- Patentansprüche**
1. Ein persönlicher Handmonitor, umfassend eine Signalerfassungseinrichtung zum Erfassen von Signalen, die verwendet werden können, um eine Messung eines auf die Gesundheit des Anwenders bezogenen Parameters abzuleiten, wobei die Signalerfassungseinrichtung aufweist:

einen Fotosensor für Blut, der einen oder meh-

rere Fotoemitter (81) zur Übertragung von Licht auf einen Körperteil eines Anwenders aufweist, einen oder mehrere Fotodetektoren (88, 108), um Licht zu detektieren, das durch den Körperteil geleitet oder von dem Körperteil gestreut wurde, und zwei oder mehr optische Zellen (86, 87), wobei mindestens eine davon einen zu detektierenden Analyten enthält oder die das Absorptionsspektrum des zu detektierenden Analyten nachahmt, durch die das Licht verläuft, das durch den Körperteil geleitet oder von diesem gestreut wurde oder werden wird, bevor es den oder jeden Fotodetektor erreicht, wobei der Prozessor des persönlichen Handmonitors angepasst ist, um die von dem oder von jedem Fotodetektor erhaltenen Signale zu verarbeiten, zur Berechnung der Differenz in der Intensität des Lichts, das die oder jede Analyt-Zelle durchlaufen hat und des Lichts, das die oder jede Nicht-Analyt-Zelle durchlaufen hat, um den Puls des Anwenders zu bestimmen und die von dem Fotosensor erhaltenen Signale mit dem Puls des Anwenders zu korrelieren,

wobei der persönliche Handmonitor angepasst ist, Druck auf den Körperteil auszuüben oder Druck auf diesen durch den Körperteil ausüben zu lassen, so dass im Gebrauch, eine Arterie in dem Körperteil aus dem geschlossenen Zustand in den offenen Zustand während jedes Pulses wechselt und der Prozessor des persönlichen Handmonitors angepasst ist, eine Messung der Veränderung der luminalen Querschnittsfläche der Arterie während jedes Pulses abzuleiten und die von dem Fotosensor für Blut empfangenen Signale mit dem Puls und der Veränderung der luminalen Querschnittsfläche der Arterie zu korrelieren, um eine Messung der Konzentration des Analyten in dem arteriellen Blut zu liefern.

2. Der persönliche Handmonitor gemäß Anspruch 1, wobei der persönliche Handmonitor angepasst ist, gegen den Körperteil gedrückt werden, oder den Körperteil von dem Anwender an diesen drücken zu lassen, um die luminalen Querschnittsfläche der Arterie zu verändern.
3. Der persönliche Handmonitor gemäß Anspruch 2, wobei der Prozessor des persönlichen Handmonitors angepasst ist, dem Anwender optische und/oder akustische Anweisungen bereitzustellen, um den auf den oder durch den Körperteil ausgeübten Druck zu verändern, so dass die Änderung der luminalen Querschnittsfläche der Arterie mit jedem Puls maximiert wird.
4. Der persönliche Handmonitor gemäß irgendeinem der Ansprüche 1 bis 3, wobei der oder jeder Fotoe-

mitter ein thermischer Strahler ist.

5. Der persönliche Handmonitor gemäß Anspruch 4, wobei die Temperatur eines jeden Fotoemitters durch Rückkopplung gesteuert wird, die den Strom durch oder die Spannung über dem Fotoemitter reguliert.
6. Der persönliche Handmonitor gemäß irgendeinem der Ansprüche 1 bis 5, wobei das Licht mittels Faseroptik zu und/oder von dem Körperteil übertragen wird.
7. Der persönliche Handmonitor gemäß irgendeinem der Ansprüche 1 bis 6, umfassend Mittel zur teilweisen oder vollständigen Dämpfung des von dem oder jedem Fotoemitter emittierten Lichts.
8. Der persönliche Handmonitor gemäß irgendeinem der Ansprüche 1 bis 7, wobei der Prozessor des persönlichen Handmonitors angepasst ist, um die berechnete Differenz zwischen den von dem Fotosensor empfangenen Signalen zu normalisieren durch Berücksichtigung des gemessenen Wertes von jedem solcher Signale, von den Signalen des Fotodetektors, wenn der Fotoemitter vollständig gedämpft wird, von ähnlichen Signalen des Fotosensors, wenn der Körperteil nicht gegenwärtig ist, und von allen Signalen, die von den Mitteln abgeleitet werden, die verwendet werden, um die Änderung der luminalen Querschnittsfläche der Arterie zu erfassen.
9. Der persönliche Handmonitor gemäß irgendeinem der Ansprüche 1 bis 8, wobei die Zellen eine rotierende Scheibe aufweisen, wobei ein oder mehrere Teile davon mit dem Analyten beschichtet sind oder eine Lösung des Analyten tragen, oder die das Absorptionsspektrum des Analyten imitieren, und die anderen Teile der Scheibe dies nicht tun.
10. Der persönliche Handmonitor gemäß irgendeinem der Ansprüche 1 bis 9, wobei eine oder mehrere Verschlüsse verwendet werden, um den Weg des Lichts durch den Fotosensor für Blut auszuwählen.
11. Der persönliche Handmonitor gemäß Anspruch 10, wobei die optischen Verschlüsse elektrooptische Vorrichtungen sind.
12. Der persönliche Handmonitor gemäß irgendeinem der Ansprüche 1 bis 11, wobei der oder jeder Fotodetektor aus InGaAs gebildet wird.
13. Der persönliche Handmonitor gemäß irgendeinem der Ansprüche 1 bis 12, wobei der Analyt Glucose, Ethanol, Hämoglobin, Kreatinin oder Cholesterin ist.
14. Der persönliche Handmonitor gemäß irgendeinem

der Ansprüche 1 bis 12, wobei der Analyt ein illegales oder anderweitig verbotenes Arzneimittel oder Stimulans ist.

15. Der persönliche Handmonitor gemäß irgendeinem der Ansprüche 1 bis 14, wobei das optische System integriert ist. 5
16. Der persönliche Handmonitor gemäß irgendeinem der Ansprüche 1 bis 15, welcher einen elektrischen Sensor beinhaltet, umfassend mindestens eine erste und eine zweite Elektrode, die elektrisch voneinander isoliert sind und die arrangiert werden, um mit zwei getrennten Teilen des Körpers des Anwenders in Kontakt zu treten, beispielsweise einem Finger der einen Hand und einem Finger der anderen Hand, und der Prozessor des persönlichen Handmonitors angepasst ist, um die Signale von dem elektrischen Sensor zu analysieren, um den Puls des Anwenders zu bestimmen. 10
17. Der persönliche Handmonitor gemäß irgendeinem der Ansprüche 1 bis 16, der in sich geschlossen ist und einen Prozessor, Anzeige und Steuerung, Kommunikations- und Speichermittel aufweist, um eine Messung der Konzentration des Analyten in dem Blut des Anwenders bereitzustellen. 15
18. Der persönliche Handmonitor gemäß irgendeinem der Ansprüche 1 bis 17, wobei die Signalerfassungseinrichtung mit einem persönlichen Hand-Computergerät integriert ist. 20

Revendications 25

1. Moniteur portatif personnel (PHHM) comprenant un dispositif d'acquisition de signaux pour acquérir des signaux qui peuvent être utilisés pour dériver une mesure d'un paramètre lié à la santé de l'utilisateur, le dispositif d'acquisition de signaux comprenant un photocapteur sanguin ayant un ou plusieurs photoémetteurs (81) pour transmettre de la lumière à une partie corporelle d'un utilisateur, un ou plusieurs photodétecteurs (88 ; 108) pour détecter la lumière transmise à travers ou diffusée par la partie corporelle et deux ou plusieurs cellules optiques (86 ; 87), dont au moins une contient un analyte à détecter ou qui imite le spectre d'absorption de l'analyte à détecter, à travers lesquelles la lumière qui a été ou sera transmise à travers ou diffusée par la partie corporelle passe avant d'atteindre le ou chaque photodétecteur, dans lequel le processeur du PHHM est adapté pour traiter des signaux reçus en provenance du ou de chaque photodétecteur pour calculer la différence d'intensité de la lumière qui a traversé la ou chaque cellule d'analyte et la lumière qui a traversé la ou chaque cellule non analyte, pour déterminer 30

les battements de coeur de l'utilisateur et pour corréler les signaux obtenus à partir du photocapteur avec les battements de coeur de l'utilisateur, dans lequel le PHHM est adapté pour appliquer une pression à la partie corporelle ou pour se voir appliquer une pression par la partie corporelle de sorte que, en utilisation, une artère dans la partie corporelle passe de l'état occlus à l'état persistant pendant chaque battement de coeur et le processeur du PHHM est adapté pour dériver une mesure du changement de la zone luminale de l'artère pendant chaque battement de coeur et pour corréler les signaux reçus en provenance du photocapteur sanguin avec les battements de coeur et le changement de la zone luminale de l'artère pour fournir une mesure de la concentration de l'analyte dans le sang artériel. 35

2. PHHM selon la revendication 1, dans lequel le PHHM est adapté pour être appuyé contre la partie corporelle ou pour avoir la partie corporelle appuyée contre lui par un utilisateur pour faire varier la zone luminale de l'artère. 40
3. PHHM selon la revendication 2, dans lequel le processeur du PHHM est adapté pour fournir des instructions visuelles et/ou sonores à l'utilisateur pour faire varier la pression appliquée à ou par la partie corporelle de sorte que le changement de zone luminale de l'artère avec chaque battement de coeur soit maximisé. 45
4. PHHM selon l'une quelconque des revendications 1 à 3, dans lequel le ou chaque photoémetteur est un émetteur thermique. 50
5. PHHM selon la revendication 4, dans lequel la température de chaque photoémetteur est réglée au moyen d'une rétroaction qui régule le courant à travers ou la tension aux bornes du photoémetteur. 55
6. PHHM selon l'une quelconque des revendications 1 à 5, dans lequel la lumière est transmise à et/ou en provenance de la partie corporelle au moyen de fibres optiques.
7. PHHM selon l'une quelconque des revendications 1 à 6, comportant un moyen d'atténuation partielle ou totale de la lumière émise par le ou chaque photoémetteur.
8. PHHM selon l'une quelconque des revendications 1 à 7, dans lequel le processeur du PHHM est adapté pour normaliser la différence calculée entre les signaux provenant du photocapteur en prenant en compte la valeur mesurée de chacun de ces signaux, le signal provenant du photodétecteur lorsque le photoémetteur est totalement atténué, des signaux similaires provenant du photocapteur lorsque la par-

tie corporelle n'est pas présente et tout signal dérivé du moyen utilisé pour détecter le changement de zone luminale de l'artère.

9. PHHM selon l'une quelconque des revendications 1 à 8, dans lequel les cellules comprennent un disque rotatif, dont une ou plusieurs parties sont revêtues de ou portent en solution l'analyte ou qui imitent le spectre d'absorption de l'analyte et pas les autres parties. 5
10
10. PHHM selon l'une quelconque des revendications 1 à 9, dans lequel un ou plusieurs volets sont utilisés pour sélectionner le trajet de la lumière à travers le photodétecteur sanguin. 15
11. PHHM selon la revendication 10, dans lequel les volets optiques sont des dispositifs électro-optiques.
12. PHHM selon l'une quelconque des revendications 1 à 11, dans lequel le ou chaque photodétecteur est composé d'InGaAs. 20
13. PHHM selon l'une quelconque des revendications 1 à 12, dans lequel l'analyte est le glucose, l'éthanol, l'hémoglobine, la créatinine ou le cholestérol. 25
14. PHHM selon l'une quelconque des revendications 1 à 12, dans lequel l'analyte est une drogue ou un stimulant illicite ou sinon interdit. 30
15. PHHM selon l'une quelconque des revendications 1 à 14, dans lequel le système optique est intégré.
16. PHHM selon l'une quelconque des revendications 1 à 15, qui comporte un capteur électrique comprenant au moins une première et une seconde électrode qui sont isolées électriquement l'une de l'autre et qui sont agencées pour être mises en contact par deux parties séparées du corps de l'utilisateur, tel qu'un doigt d'une main et un doigt de l'autre main, et le processeur du PHHM est adapté pour analyser les signaux provenant du capteur électrique pour déterminer les battements de coeur de l'utilisateur. 35
40
45
17. PHHM selon l'une quelconque des revendications 1 à 16, qui est autonome et comporte un processeur, un afficheur et une commande, un moyen de communication et de stockage pour fournir une mesure de la concentration de l'analyte dans le sang de l'utilisateur. 50
18. PHHM selon l'une quelconque des revendications 1 à 17, dans lequel le dispositif d'acquisition de signaux est intégré à un dispositif informatique portatif personnel (PHHCD). 55

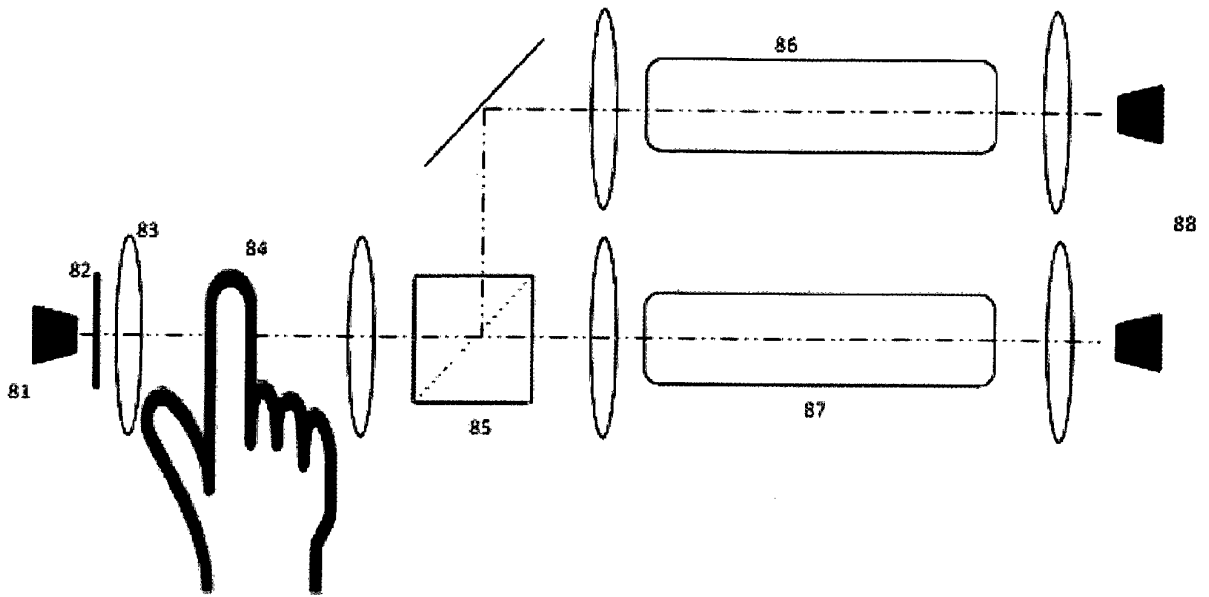

Figure 1

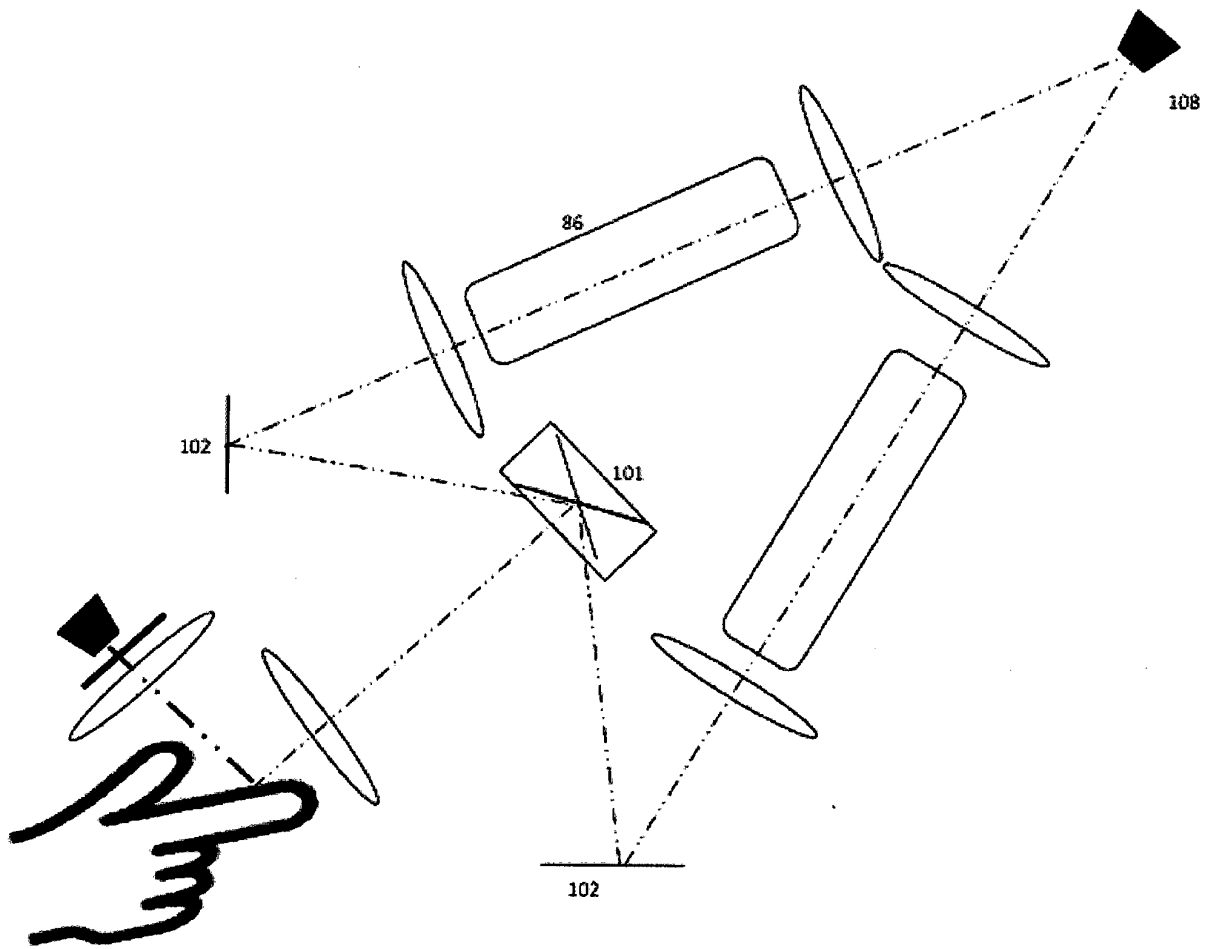

Figure 2

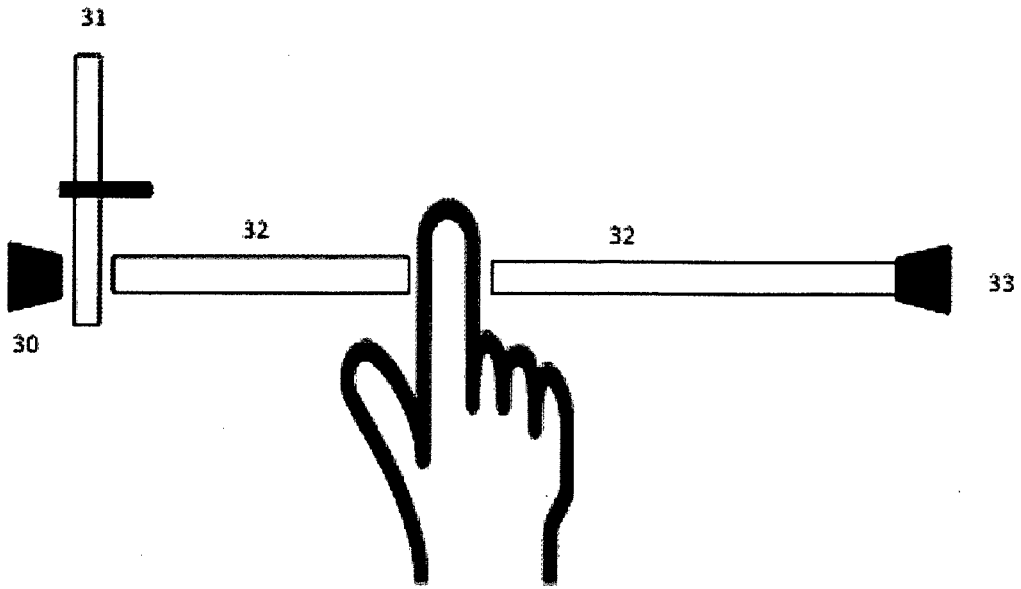

Figure 3

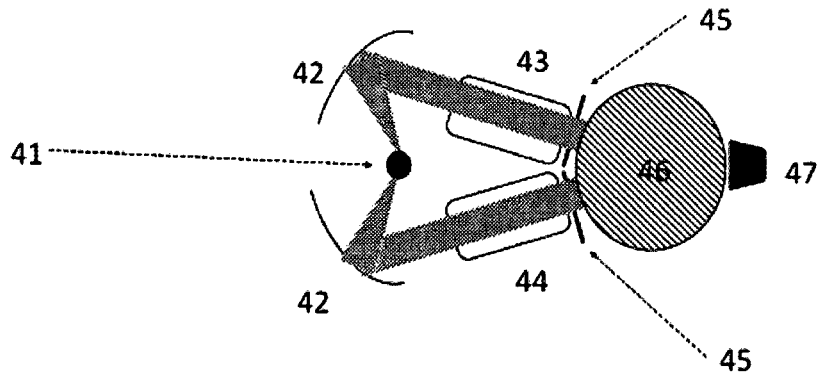

Figure 4

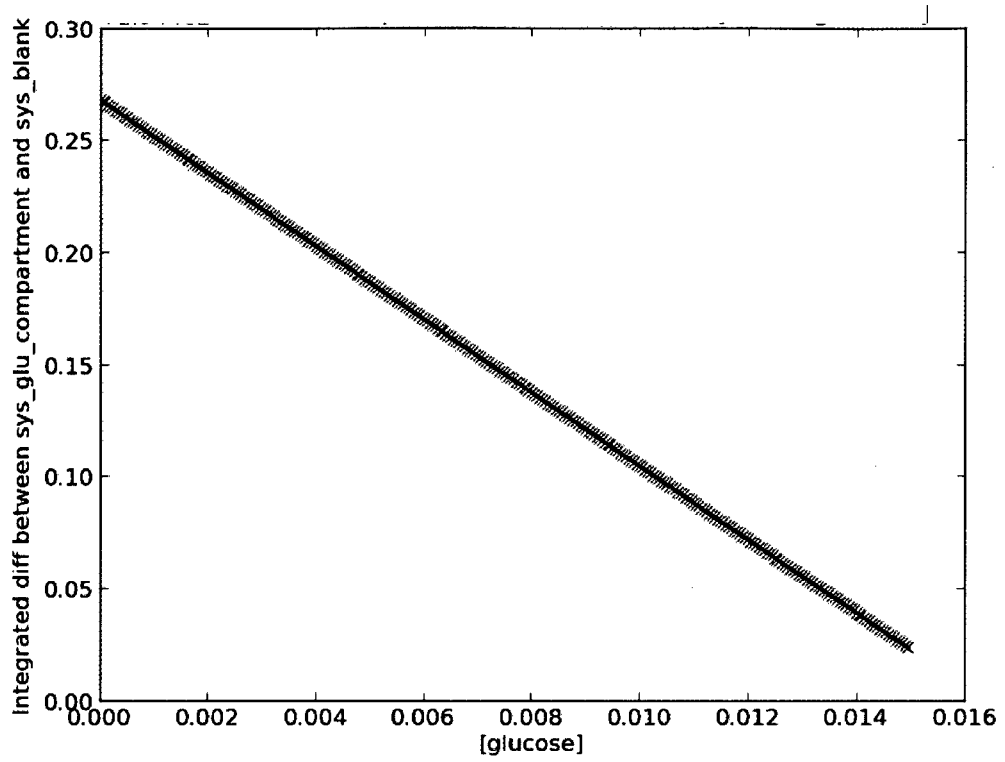

Figure 5

REFERENCES CITED IN THE DESCRIPTION

This list of references cited by the applicant is for the reader's convenience only. It does not form part of the European patent document. Even though great care has been taken in compiling the references, errors or omissions cannot be excluded and the EPO disclaims all liability in this regard.

Patent documents cited in the description

- US 4882492 A [0007] [0010]
- WO 2013001265 A [0010] [0011] [0015] [0016] [0017] [0029] [0033]
- WO 2103001265 A [0039]

Non-patent literature cited in the description

- **DANA EI et al.** National, regional, and global trends in fasting plasma glucose and diabetes prevalence since 1980: systematic analysis of health examination surveys and epidemiological studies with 370 country-years and 2.7 million participants. *Lancet*, 2011, vol. 378 (9785), 31-40 [0002]
- Global status report on non-communicable diseases 2010. WHO, 2011 [0002]
- **KLONOFF.** Non-invasive blood glucose monitoring. *Diabetes Care*, 1997, vol. 20 (3), 435-437 [0005]
- Handbook of optical sensing of glucose in biological fluids and tissues. 2009 [0009]

专利名称(译)	无创血液分析		
公开(公告)号	EP2922468B1	公开(公告)日	2016-06-08
申请号	EP2014708642	申请日	2014-02-10
[标]申请(专利权)人(译)	LEMAN MICRO DEVICES		
申请(专利权)人(译)	LEMAN MICRO DEVICES SA		
当前申请(专利权)人(译)	LEMAN MICRO DEVICES SA		
[标]发明人	ELLIOTT CHRISTOPHER JONES MARK ERIC VARSHNEY ARUSHI RUEGG MATTHIEU		
发明人	ELLIOTT, CHRISTOPHER JONES, MARK-ERIC VARSHNEY, ARUSHI RUEGG, MATTHIEU		
IPC分类号	A61B5/1455 A61B5/00 A61B5/022		
CPC分类号	A61B5/14532 A61B5/14557 A61B5/02233 A61B5/0261 A61B5/14546 A61B5/0205 A61B5/02427 A61B5/0245 A61B5/1455 A61B5/489 A61B5/6897 A61B5/6898 A61B5/7405 A61B5/742 A61B2560 /0425 A61B2562/0238		
优先权	2013002548 2013-02-13 GB 2013016914 2013-09-23 GB 2013016915 2013-09-23 GB		
其他公开文献	EP2922468A1		
外部链接	Espacenet		

摘要(译)

本发明提供了一种个人手持监视器 (PHHM) , 包括用于获取信号的信号获取装置, 该信号可用于导出与用户健康有关的参数的测量, 其中信号获取装置包括具有血液光传感器的血液光传感器。用于将光传输到用户身体部位的一个或多个光发射器, 用于检测透过身体部分或由身体部分散射的光的一个或多个光检测器以及两个或更多个光学单元, 其中至少一个包含分析物可以检测或模拟分析物的吸收光谱, 通过该分析物已经或将要通过身体部分传播或散射的光在到达光检测器之前通过, 其中PHHM的处理器被调整处理从或接收的信号每个光检测器计算已通过该分析物细胞或每个分析物细胞的光强度与通过该非分析物细胞或每个非分析物细胞的光的强度差异, 以确定用户的脉搏并使从中获得的信号相关联。具有使用者脉搏的光传感器, 其中PHHM适于向身体部分施加压力或者通过身体部分施加压力, 使得在使用中, 身体部分中的动脉在每个脉冲期间从闭塞变为专利。并且PHHM的处理器适于在每个脉冲期间导出动脉腔面积变化的测量值, 并将从血液光传感器接收的信号与脉冲和动脉腔面积的变化相关联以提供测量动脉中分析物的浓度血液。

