

(19)



(11)

EP 1 736 041 B1

(12)

EUROPEAN PATENT SPECIFICATION

(45) Date of publication and mention of the grant of the patent:
12.06.2013 Bulletin 2013/24

(51) Int Cl.:
H05K 5/06 (2006.01) A61B 5/00 (2006.01)

(21) Application number: **05731370.2**

(86) International application number:
PCT/US2005/011653

(22) Date of filing: **07.04.2005**

(87) International publication number:
WO 2005/107351 (10.11.2005 Gazette 2005/45)

(54) **A HOUSING FOR A CIRCUIT THAT IS TO BE IMPLANTED IN-VIVO AND PROCESS OF MAKING THE SAME**

EINE SCHALTKREISVERKAPPUNG DIE IN-VIVO IMPLANTIERT WIRD UND PROZESS ZUR HERSTELLUNG DERSELBEN

LOGEMENT POUR CIRCUIT A IMPLANTER IN VIVO ET PROCEDE DE REALISATION DUDIT LOGEMENT

(84) Designated Contracting States:
AT BE BG CH CY CZ DE DK EE ES FI FR GB GR HU IE IS IT LI LT LU MC NL PL PT RO SE SI SK TR

• **WALTERS, Steven J.**
Ellicott City, MD 21042 (US)

(30) Priority: **16.04.2004 US 825648**

(74) Representative: **Charlton, Peter John**
Elkington and Fife LLP
Prospect House
8 Pembroke Road
Sevenoaks,
Kent TN13 1XR (GB)

(43) Date of publication of application:
27.12.2006 Bulletin 2006/52

(60) Divisional application:
10182071.0 / 2 259 670

(56) References cited:
EP-A- 0 940 076 US-A- 5 840 148
US-A1- 2002 026 108 US-A1- 2003 181 794

(73) Proprietor: **Senseonics, Incorporated**
Germantown, MD 20876-7005 (US)

(72) Inventors:
• **COLVIN, JR, Arthur E.**
Mt. Airy, MD 21771 (US)
• **LORENZ, Carrie R.**
Woodbine, MD 21797 (US)
• **O'CONNOR, Casey J.**
Gaithersburg, MD 20877 (US)

• **LOVELY D F ET AL: "Epoxy moulding system for the encapsulation of microelectronic devices suitable for implantation" MEDICAL & BIOLOGICAL ENGINEERING & COMPUTING UK, vol. 24, no. 2, March 1986 (1986-03), pages 206-208, XP001206580 ISSN: 0140-0118**

EP 1 736 041 B1

Note: Within nine months of the publication of the mention of the grant of the European patent in the European Patent Bulletin, any person may give notice to the European Patent Office of opposition to that patent, in accordance with the Implementing Regulations. Notice of opposition shall not be deemed to have been filed until the opposition fee has been paid. (Art. 99(1) European Patent Convention).

Description

BACKGROUND OF THE INVENTION

1. Field of the invention

[0001] The present invention relates to a circuit housing, and, more specifically, to a housing for a circuit-designed to be implanted in-vivo (i.e., an implantable circuit).

2. Discussion of the Background

[0002] There are several applications that require a circuit to be protected from the environment in which the circuit is intended to operate. For example, a human implantable glucose sensor circuit must be housed within a suitable housing to both protect the sensor from the human body and to protect the human body from the sensor. U.S. Pat. No. 6,330,464, discloses such a sensor.

[0003] A housing encasing an implantable circuit should have at least some of the following characteristics: (1) the ability to protect the electronic circuitry of the sensor from the ambient in-vivo chemical and physical environment, (2) the ability to protect tissue adjacent to the sensor from any adverse reaction which could result as a consequence of contact (or leachables) from within the circuitry - in addition, beyond the adjacent tissue, the encasement must not permit leachables of any detectable significance into the general body environment; (3) the ability to permit wireless electronic communication between the circuitry and an external reader for power and signal; (4) the ability to permit free passage of wavelengths of light necessary for optical functioning of the sensor; (5) the ability to support the surface chemistry required to form a chemical recognition "front-end"; (6) the housing should be high volume manufacture-able; (7) the housing must be non-toxic and "biocompatible"; and (8) provide a sufficiently high reliability to meet the specifications of a medical product.

[0004] US-A-2003/181794 discloses an in vivo implantable sensor unit which includes a glass sensor housing defining an elongated chamber. Sensor electronics are disposed in the chamber. The sensor electronics are adapted to wirelessly transmit data. The sensor unit is configured to wirelessly transmit data from an in vivo position to a remote receiver over a period of several weeks and the sensor housing is adapted to provide a hermetic seal about the sensor electronics for several weeks.

SUMMARY OF THE INVENTION

[0005] The present invention provides a biocompatible, human implantable apparatus, comprising: a circuit and a glass housing comprising a glass tube having an open end and a glass ball sealing said open end of said tube; characterized in that the apparatus further comprises: a fully enclosed housing within which said glass hous-

ing is housed; a brick of epoxy within which the circuit is encased, wherein the brick of epoxy containing the circuit is housed within said glass housing; and a second optical epoxy disposed between an outer surface of the brick of epoxy and an inner surface of said glass housing.

[0006] In another aspect, the present invention provides a method for fully encasing a circuit within a housing, comprising: inserting the circuit into the glass housing; injecting an optical epoxy into a glass housing; and capping an open end of the glass housing; characterized in that the method further comprises: injecting an optical epoxy into a second housing; inserting into the second housing the glass housing containing the circuit; and capping an open end of the second housing.

[0007] The above and other features and advantages of the present invention, as well as the structure and operation of preferred embodiments of the present invention, are described in detail below with reference to the accompanying drawings.

BRIEF DESCRIPTION OF THE DRAWINGS

[0008] The accompanying drawings, which are incorporated herein and form part of the specification, help illustrate various embodiments of the present invention and, together with the description, further serve to explain the principles of the invention and to enable a person skilled in the pertinent art to make and use the invention. In the drawings, like reference numbers indicate identical or functionally similar elements. Additionally, the left-most digit(s) of a reference number identifies the drawing in which the reference number first appears.

[0009] FIG. 1 illustrates one embodiment of a circuit assembly.

[0010] FIG. 2 is a flow chart illustrating a process for encasing a circuit within a polymer housing.

[0011] FIG. 3 is a cross sectional view of a circuit assembly.

[0012] FIG. 4 is a flow chart illustrating a process for encasing a circuit within a polymer housing.

[0013] FIG. 5 is an exploded view of a circuit assembly.

[0014] FIG. 6 is a cross sectional view of a circuit assembly.

[0015] FIG. 7 illustrates a circuit assembly according to an embodiment of the present invention.

[0016] FIG. 8 is an exploded view of a circuit assembly according to an embodiment of the invention.

[0017] FIG. 9 is a flow chart illustrating a process, according to an embodiment, for encasing a circuit within a polymer housing.

[0018] FIGS. 10A and 10B illustrate a circuit covered with different amount of epoxy.

DETAILED DESCRIPTION OF THE PREFERRED EMBODIMENT

[0019] FIG. 1 illustrates one embodiment of a circuit assembly 100. As shown in FIG. 1, an assemblage in-

cluding a circuit 101 is housed within a fully enclosed housing 102. Preferably, as shown in FIG. 1, housing 102 is capsule shaped, but other shapes may be used. Circuit 101 may be an electronic circuit having a printed circuit board 110 and one or more electrical and optical components 112 attached to the circuit board 110. Circuit 101 may include a conventional sensor, such as the sensor described in U.S. Patent No. 6,304,766. The housing 102 may be a housing made from PMMA, which is a polymer of methyl methacrylate (MMA) monomers, or from other organic polymers.

[0020] FIG. 2 is a flow chart illustrating a process 200 for creating circuit assembly 100. Process 200 may begin in step 202, where a polymerization initiator is added to a mold. In step 204, an encasement formulation containing monomers is poured into the mold (e.g., filling the mold halfway). In step 206, circuit 101 is placed in the mold. In step 208, more of the encasement formulation is poured into the mold so that the circuit is completely immersed in the encasement formulation. Preferably the encasement formulation includes monomers, and may consist of or essentially consist of MMA monomers. In this manner, one can encase circuit 101 in a polymer housing.

[0021] In some situations, for example, situations where the formulation includes MMA monomers and circuit 101 is relatively large, circuit 101 can become severely damaged during the polymerization process (i.e., during step 206). The cause of this damage is usually attributed to the shrinkage that occurs naturally during polymerization of MMA. In the joining of bonds between monomers contained within a neat solution of MMA, the intermolecular spacing is reduced within a polymer as the reaction progresses. This is a well-known phenomena and typical of most, if not all, polymer reactions. The net volumetric shrinkage that occurs during the polymerization of PMMA from neat monomer solution is approximately 14%.

[0022] This shrinkage can, in some circumstances, create a particular problem when using PMMA as a circuit housing because, as the encasement reaction progresses, and the viscosity increases as the shrinkage occurs simultaneously, the electrical components 112, which are mounted on the circuit board 110 typically with conductive epoxy, are pulled from the circuit board 110 during the polymerization process.

[0023] The relative strength of the conductive epoxy used to hold the components 112 in place, which conductive epoxy is formulated primarily and maximally for its electrical conductance and cure properties, does not have sufficient mechanical strength to withstand the pull and stress from PMMA shrinkage as the encasement reaction progresses. Consequently, some attempts to encase a circuit from an MMA monomer encasement formulation result in a non-functional circuit because of unrepairable mechanical damage.

[0024] To solve this problem, one aspect of the present invention is a method by which the polymerization reac-

tion can be conducted without damage to the encased circuit 101. Because pre-polymerized PMMA of large molecular weights (approximately up through 1 million + mw) can be dissolved in MMA monomer, and because the shrinkage is a direct result of bonds forming from discrete monomers, one possible solution is to formulate the encasement formulation to include a portion of MMA monomer and a portion of pre-polymerized PMMA dissolved within the MMA monomer.

[0025] The net shrinkage is proportional to the amount of monomer which is reacted to become polymer within the overall volume. If the overall encasement formulation volume, is portioned to include, for example, about 70% pre-polymerized PMMA, and about 30% un-reacted MMA monomer (into which the 70% PMMA has been dissolved), then the degree of shrinkage which occurs drops in direct proportion to the monomer component within the overall volume. In practice, an encasement formulation of 100% MMA monomer shrinks volumetrically about 14% overall. By dropping the formulation to only 30% MMA, shrinkage in the amount of approximately $0.3 \times 14 = 4.3\%$ would be expected. In practice, approximately 4% shrinkage is measured from making this improvement.

[0026] Accordingly, the result of altering percent solids provides an improvement in system stress during encasement by reducing shrinkage from, for example, 14% to 4% by reformulating MMA/PMMA specifically for the encasement process. Formulation ratios of 60-80% PMMA in MMA are preferred, although not required, because of a present practical limitation. Although to a point, higher ratio values would be expected to reduce shrinkage proportionately, and further reduction in shrinkage may be possible. As a practical matter, the solution viscosity becomes extremely high at these higher ratio levels making the high solids solution extremely difficult to handle, transfer, etc.

[0027] In some situations, however, even with 4% shrinkage, which is a great improvement over 14%, some percentage (about 40-50%) of circuits 101 can not withstand the 4% shrinkage of the encasement. The surviving circuits tend to have greater amounts of conductive epoxy to increase mechanical strength slightly of the surface mounted parts. However, conductive epoxy is not sufficiently strong, and to increase the amount used per connection beyond good manufacturing standards would then create other problems. Another important consideration is for wire-bonded circuits. These "frog hair" gold wires are typically 25 microns in diameter which is about 1/3 to 1/4 the diameter of a typical human hair. Small amounts of movement relative to the fixed board components can rip these wires from the attachments.

[0028] Accordingly, in some applications, it is desirable to mechanically strengthen the circuit 110 to allow it to withstand the remaining shrinkage from the PMMA encasement cure reaction.

[0029] One way to mechanically strengthen circuit 101 to allow it to withstand the remaining 4% shrinkage from

the PMMA (70/30) encasement cure reaction, is to reinforce the circuit with a pre-applied epoxy layer. For example, following assembly of the electrical components to the circuit board and cleaning of the assembly, an epoxy is applied over the circuit, which epoxy both underfills and overfills the components attached to the circuit board. Surprisingly, it was discovered that this solution works best when the applied epoxy covers the components in such a way as to result in a relatively "smooth" surface topology, but this is not a requirement. This "smooth" surface topology is illustrated in FIG. 10A. For comparison, FIG. 10B shows a "non-smooth" epoxy coating. As shown in FIG. 10A, the surface 1002 of the epoxy coating is smooth or substantially smooth.

[0030] Although the epoxy adequately strengthens circuit 101 against damage from the shrinking polymer, the resultant stress caused by the remaining 4% shrinkage then becomes manifest as de-lamination between the adjoining surfaces of epoxy and PMMA within the final encasement. As mentioned above, it was discovered that if the surface was smoothed by the volume and application of the epoxy pre-coat, not allowing the PMMA to get a "grip" within the surface topology, then de-lamination was less likely to occur. The stress from the 4% remaining shrinkage is then absorbed as internal stress within the PMMA encasement body itself. This stress may be removed in a conventional way by annealing in a final operation.

[0031] Some or all of the epoxy used to reinforce the circuit 110 may, in some embodiments, include a light blocking pigment (such as black or wavelength specific) which prevents unwanted light propagation and scatter about the circuit, thereby increasing the optical signal to noise ratio of the system.

[0032] In some embodiments, to prolong the life of the circuitry 101, it may be desirable to prevent molecular water vapor that has seeped through the housing 102 from condensing to become liquid water. If liquid water cannot form from the water vapor, then potential ion contaminants present cannot become solvated, which can lead to circuit failure.

[0033] One way to prevent the water vapor from condensing is to prevent the formation of heat induced bubbles in the encasement polymer. MMA monomer is extremely volatile. The polymerization reaction of MMA to PMMA is also exothermic. The exothermic heat yield from a typical reaction begun at room temperature will commonly increase the temperature as the reaction progresses to a point where the remaining un-reacted monomer will boil and create bubbles of all sizes trapped within the cured polymer. To prevent any possibility of heat induced micro-bubbles and voids within the housing where water vapor could condense, substantial overpressure may be used during the polymerization reaction. More specifically, in a preferred embodiment, a mold containing PMMA/MMA is placed within a pressure reactor that is then pressurized to a pressure that exceeds the vapor pressure of MMA monomer at the polymeriza-

tion temperature. This pressurization process both prevents bubbles and provides a very close mechanical surface bond with the underlying epoxy coat which does not delaminate once formed. The housing is clear and without bubble or void defects to prevent water from condensing; and as an important byproduct, provides excellent optical clarity without bubble defect.

[0034] Referring now to FIG. 3, FIG. 3 is a cross sectional view of circuit assembly 100 along line A. As shown in FIG. 3, the circuit 101 may be fully encased within a brick of epoxy 302 (or "epoxy brick 302"), which is encased within housing 102.

[0035] FIG. 4 is a flow chart illustrating a process 400, for creating circuit assembly 100. Process 400 may begin in step 402, where a housing 500 (e.g., a sleeve 500 or tube or other housing having an open end) (see FIG. 5) is created along with a plug 504 for plugging the opening in the housing. For example, a cylindrical sleeve 500 and plug 504 may be machined from a polymer rod, such as a rod of PMMA or other organic polymer. As shown in FIG. 5, sleeve 500 may have a notch 592 adjacent to the open end 594 of sleeve 500. If sleeve 500 and plug 504 are made from PMMA, the PMMA sleeve and plug may be annealed at approximately 80°C for about four hours (step 403).

[0036] In step 404, epoxy is applied over the circuit 101 so that the circuit is partially or fully encased within an epoxy brick 502, thereby forming an assembly 503. In step 406, assembly 503, sleeve 500 and plug 504 are cleaned. For example, assembly 503, sleeve 500 and plug 504 may be cleaned by rubbing a Q-tip with IPA on the surfaces thereof. In step 408, an optical epoxy is prepared. EPO-TEK 301-2 Epoxy from Epoxy Technology of Billerica, MA and other epoxies may be used as the optical epoxy.

[0037] In step 410, the circuit encased within the epoxy brick (i.e., assembly 503) is placed into the sleeve 500. In step 412, the prepared optical epoxy is injected (i.e., introduced) into sleeve 500. Preferably, no bubbles in the optical epoxy are formed during step 412. In step 414, the plug 504 is placed into the open end of sleeve 500, thereby sealing the open end of the sleeve.

[0038] FIG. 6 is a cross sectional view of the circuit assembly 100 along line A after step 414 is performed. In the embodiment shown in FIG. 6, the circuit 101 is fully encased within an epoxy brick 502. The epoxy brick 502, which houses circuit 101 is placed within sleeve 500, which may be a cylindrical sleeve. When sleeve 500 is a cylindrical sleeve and when circuit 101 is fully encased within the epoxy brick, it is preferable that the distance between the upper right hand corner and lower left corner of epoxy brick 502 be equal to or slightly less than the inner diameter of sleeve 502. That is, in some embodiments it is preferable that $w = \sqrt{(d^2 - (h^2))}$, where w is the width of assembly 503, h is the height of assembly 503, and d is the inner diameter of sleeve 500. In embodiments where the assembly 503 does not have a uniform width or has a circular shaped cross section, then

the maximum width of the assembly may be equal to or slightly less than the inner diameter. As illustrated in FIG. 6, the optical epoxy (e.g., a refractive index (RI) matching epoxy) fills spaces between assembly 503 and sleeve 500.

[0039] Referring back to FIG. 4, in step 416, the new assembly (i.e., the sealed sleeve containing the epoxy and assembly 503) is placed into a pressure vessel. In step 418, the pressure within the vessel is increased to about 125psi using Nitrogen or other inert gas. In step 420, the optical epoxy is cured for an amount of time (e.g., 20 hours) at a predetermined temperature (e.g., 40°C). After the predetermined amount of time has elapsed, the assembly is removed from the pressure vessel and then final machined (step 422).

[0040] The method described above allows the possibility of annealing a PMMA housing before encasement without putting any additional stress on the circuit 101.

[0041] FIG. 7 illustrates an alternative circuit assembly 700 of the present invention. Circuit assembly 700 is similar to circuit assembly 100 in that assembly 700 includes a circuit 101 housed within a housing 102. However, in assembly 700, the circuit 101 is also housed within a glass housing 702 (e.g., a tube or other shaped housing), which itself is housed within the housing 102. The glass housing 702, in some embodiments, is closed at one end and open at the opposite end. The open end may be plugged by a glass ball 704 or other suitable plug. FIG. 8 is an exploded view showing the components of assembly 700, according to one embodiment. Glass housing 702, in some embodiments, may be constructed from an infra-red (IR) blocking glass.

[0042] FIG. 9 is a flow chart illustrating a process 900, according to one embodiment, for making assembly 700. Process 900 may begin in step 902, where a sleeve and a plug, such as sleeve 500 and plug 504, are created.

[0043] In step 904, the sleeve and plug are annealed. The sleeve and plug may be annealed at 80°C for about four hours. In step 906, the components (e.g., sleeve 500, plug 504, glass housing 702, glass ball 704, epoxy brick 502, etc.) are cleaned. For example, sleeve 500 and plug 504 may be cleaned in an ultrasonic bath with IPA followed by a rinse step, and glass housing 702 and glass ball 704 may also be cleaned ultrasonically with KOH/alcohol solutions and then rinsed with water.

[0044] In step 908, a bonding agent is applied to the glass housing 702 and glass ball 704. The bonding agent used may be trimethoxy [2-(7-oxabicyclo [4.1.0]hept-3-yl)ethyl] silane, which may be purchased from Sigma-Aldrich Corporation (catalog no. 413321)

[0045] In step 910, a batch of optical epoxy is prepared. In step 912, the epoxy coated circuit board is inserted into the glass housing. In step 914, some of the prepared epoxy is injected into the glass housing 702.

[0046] In step 916, some of the prepared epoxy is injected into the sleeve 500. In step 918, glass housing 702, which houses the circuit, is inserted into an open end of the sleeve. In step 920, the glass ball 704 is in-

serted into the open end of glass housing 702, thereby sealing the open end of the glass housing. In step 922, the plug 504 is used to seal the open end of the sleeve.

[0047] In step 924, the sealed sleeve, which houses glass housing 702, which houses the circuit 101, is placed into a pressure vessel where the pressure is increased to about 125psi using an inert gas and the temperature is increased to about 40°C. After about 20 hours, the pressure is gradually reduced and the assembly is removed from the pressure vessel and then final machined (step 926).

[0048] Although the above described processes are illustrated as a sequence of steps, it should be understood by one skilled in the art that at least some of the steps need not be performed in the order shown, and, furthermore, some steps may be omitted and additional steps added.

[0049] While various embodiments/variations of the present invention have been described above, it should be understood that they have been presented by way of example only, and not limitation. Thus, the breadth and scope of the present invention should not be limited by any of the above-described exemplary embodiments, but should be defined only in accordance with the following claims.

Claims

1. A biocompatible, human implantable apparatus (700), comprising: a circuit (101) and a glass housing (702) comprising a glass tube having an open end and a glass ball (704) sealing said open end of said tube; **characterized in that** the apparatus (700) further comprises:

a fully enclosed housing (102) within which said glass housing (702) is housed;
a brick of epoxy (502) within which the circuit (101) is encased, wherein the brick of epoxy (502) containing the circuit (101) is housed within said glass housing (702); and
a second optical epoxy disposed between an outer surface of the brick of epoxy (502) and an inner surface of said glass housing (702).

2. The apparatus of claim 1, wherein the housing (102) is a polymer housing and the polymer is an organic polymer.

3. The apparatus of claim 2, wherein the polymer housing comprises, consists or consists essentially of PMMA.

4. The apparatus of any preceding claim, wherein the housing (102) is substantially cylindrical in shape and has an inner diameter.

5. The apparatus of claim 4, wherein the housing (102) is a polymer housing and wherein the inner diameter of the polymer housing is equal or about equal to the square root of: $(w^2 + h^2)$ where w is the width of the epoxy brick and h is the height of the epoxy brick. 5
6. The apparatus of claim 1, wherein the fully enclosed housing (102) does not comprise any glass.
7. The apparatus of claim 1, comprising further optical epoxy which fills spaces between said glass housing (702) and the inner wall of said fully enclosed housing (102). 10
8. A method for fully encasing a circuit (101) within a housing (102), comprising: inserting the circuit (101) into a glass housing (702); injecting an optical epoxy into the glass housing (702); and capping an open end of the glass housing (702); **characterized in that** the method further comprises: 15
- injecting an optical epoxy into a second housing (500);
inserting into the second housing (500) the glass housing (702) containing the circuit (101); and
capping an open end of the second housing (500). 20 25
9. The method of claim 8, wherein the second housing (500) comprises or consists essentially of PMMA. 30
10. The method of claim 8 or 9, further comprising the step of encasing the circuit (101) within an epoxy brick (502) prior to placing the circuit (101) in the glass housing (702). 35
11. The method of any of claims 8 to 10, wherein the circuit (101) is inserted into the glass housing (702) after the optical epoxy is injected into the glass housing (702). 40
12. The method of any of claims 8 to 10, wherein the circuit (101) is inserted into the glass housing (702) before the optical epoxy is injected into the glass housing (702). 45
13. The method of any of claims 8 to 12, wherein the step of capping an open end of the glass housing (702) comprises the step of inserting a glass ball (704) at least partially into said open end of the glass housing (702). 50
14. The method of any of claims 8 to 13, further comprising the step of curing the optical epoxy contained in the glass housing (702) prior to inserting the glass housing (702) into the second housing (500). 55
15. The method of claim 14, wherein the step of curing

the optical epoxy comprises the step of placing the glass housing (702) containing the optical epoxy and the circuit (101) into a pressure vessel and increasing the temperature and pressure within the vessel.

16. The method of any of claims 8 to 13, further comprising the step of curing the optical epoxy contained in the glass housing (702) after inserting the glass housing (702) into the second housing (500).
17. The method of any of claims 8 to 16, wherein the optical epoxy comprises MMA monomers and pre-polymerized PMMA polymers.

Patentansprüche

1. Biokompatible, in einen Menschen implantierbare Vorrichtung (700), die Folgendes umfasst: einen Schaltkreis (101) und ein Glasgehäuse (702), das ein Glasrohr mit einem offenen Ende und eine das genannte offene Ende des genannten Rohrs verschließende Glaskugel (704) umfasst; **dadurch gekennzeichnet, dass** die Vorrichtung (700) ferner Folgendes umfasst:

ein völlig geschlossenes Gehäuse (102), in dem das genannte Glasgehäuse (702) eingeschlossen ist;

einen Epoxidstein (502), in dem der Schaltkreis (101) eingeschlossen ist, wobei der den Schaltkreis (101) enthaltende Epoxidstein (502) in dem genannten Glasgehäuse (702) untergebracht ist; und

ein zweites optisches Epoxid, das zwischen einer Außenfläche des Epoxidsteins (502) und einer Innenfläche des genannten Glasgehäuses (702) angeordnet ist.

2. Vorrichtung nach Anspruch 1, wobei das Gehäuse (102) ein Polymergehäuse ist und das Polymer ein organisches Polymer ist.
3. Vorrichtung nach Anspruch 2, wobei das Polymergehäuse PMMA beinhaltet, daraus besteht oder im Wesentlichen daraus besteht.
4. Vorrichtung nach einem der vorherigen Ansprüche, wobei das Gehäuse (102) eine im Wesentlichen zylindrische Form und einen Innendurchmesser hat.
5. Vorrichtung nach Anspruch 4, wobei das Gehäuse (102) ein Polymergehäuse ist und wobei der Innendurchmesser des Polymergehäuses gleich oder etwa gleich der Quadratwurzel von $(w^2 + h^2)$ ist, wobei w die Breite des Epoxidsteins und h die Höhe des Epoxidsteins ist.

6. Vorrichtung nach Anspruch 1, wobei das völlig umschlossene Gehäuse (102) kein Glas beinhaltet.
7. Vorrichtung nach Anspruch 1, das ferner optisches Epoxid umfasst, das Räume zwischen dem genannten Glasgehäuse (702) und der Innenwand des genannten völlig umschlossenen Gehäuses (102) füllt.
8. Verfahren zum völligen Einschließen eines Schaltkreises (101) in einem Gehäuse (102), das Folgendes beinhaltet: Einführen des Schaltkreises (101) in ein Glasgehäuse (702); Injizieren eines optischen Epoxids in das Glasgehäuse (702); und Abdecken eines oberen Endes des Glasgehäuses (702); **dadurch gekennzeichnet, dass** das Verfahren ferner Folgendes beinhaltet:
- Injizieren eines optischen Epoxids in ein zweites Gehäuse (500);
Einführen des den Schaltkreis (101) beinhaltenden Glasgehäuses (702) in das zweite Gehäuse (500); und
Abdecken eines oberen Endes des Gehäuses (500).
9. Verfahren nach Anspruch 8, wobei das zweite Gehäuse (500) PMMA beinhaltet oder im Wesentlichen daraus besteht.
10. Verfahren nach Anspruch 8 oder 9, das ferner den Schritt des Einschließens des Schaltkreises (101) in einem Epoxidstein (502) vor dem Platzieren des Schaltkreises (101) in dem Glasgehäuse (702) beinhaltet.
11. Verfahren nach einem der Ansprüche 8 bis 10, wobei der Schaltkreis (101) nach dem Injizieren des optischen Epoxids in das Glasgehäuse (702) in dieses eingeführt wird.
12. Verfahren nach einem der Ansprüche 8 bis 10, wobei der Schaltkreis (101) vor dem Injizieren des optischen Epoxids in das Glasgehäuse (702) in dieses eingeführt wird.
13. Verfahren nach einem der Ansprüche 8 bis 12, wobei der Schritt des Abdeckens eines offenen Endes des Glasgehäuses (702) den Schritt des Einführens einer Glaskugel (704) wenigstens teilweise in das genannte offene Ende des Glasgehäuses (702) beinhaltet.
14. Verfahren nach einem der Ansprüche 8 bis 13, das ferner den Schritt des Härtens des in dem Glasgehäuse (702) enthaltenen optischen Epoxids vor dem Einführen des Glasgehäuses (702) in das zweite Gehäuse (500) beinhaltet.

15. Verfahren nach Anspruch 14, wobei der Schritt des Härtens des optischen Epoxids den Schritt des Platzierens des das optische Epoxid enthaltenden Glasgehäuses (702) und des Schaltkreises (101) in einem Druckbehälter und das Erhöhen von Temperatur und Druck im Behälter beinhaltet.
16. Verfahren nach einem der Ansprüche 8 bis 13, das ferner den Schritt des Härtens des im Glasgehäuse (702) enthaltenen optischen Epoxids nach dem Einführen des Glasgehäuses (702) in das zweite Gehäuse (500) beinhaltet.
17. Verfahren nach einem der Ansprüche 8 bis 16, wobei das optische Epoxidharz MMA-Monomere und vopolymerisierte PMMA-Polymere umfasst.

Revendications

1. Appareil biocompatible, implantable chez un humain (700), comprenant : un circuit (101) et un boîtier en verre (702) comprenant un tube en verre ayant une extrémité ouverte et une boule en verre (704) obturant ladite extrémité ouverte dudit tube ; **caractérisé en ce que** l'appareil (700) comprend en outre :
- un boîtier totalement fermé (102) à l'intérieur duquel ledit boîtier en verre (702) est logé ;
une brique d'époxy (502) à l'intérieur de laquelle le circuit (101) est encastré, dans lequel la brique d'époxy (502) contenant le circuit (101) est logée à l'intérieur dudit boîtier en verre (702) ; et
un deuxième époxy optique disposé entre une surface extérieure de la brique d'époxy (502) et une surface intérieure dudit boîtier en verre (702).
2. Appareil selon la revendication 1, dans lequel le boîtier (102) est un boîtier polymère et le polymère est un polymère organique.
3. Appareil selon la revendication 2, dans lequel le boîtier polymère comprend, consiste ou consiste essentiellement en du PMMA.
4. Appareil selon l'une quelconque des revendications précédentes, dans lequel le boîtier (102) a substantiellement une forme cylindrique et est doté d'un diamètre intérieur.
5. Appareil selon la revendication 4, dans lequel le boîtier (102) est un boîtier en polymère et dans lequel le diamètre intérieur du boîtier en polymère est égal ou presque égal à la racine carrée de $(w^2 + h^2)$, où w est la largeur de la brique d'époxy et h est la hauteur de la brique d'époxy.

6. Appareil selon la revendication 1, dans lequel le boîtier totalement fermé (102) ne comprend pas de verre quelconque.
7. Appareil selon la revendication 1, comprenant en outre un époxy optique qui remplit les espaces entre ledit boîtier en verre (702) et la paroi intérieure dudit boîtier totalement fermé (102).
8. Procédé pour encastrier totalement un circuit (101) à l'intérieur d'un boîtier (102), comprenant les étapes consistant à : insérer le circuit (101) dans un boîtier en verre (702) ; injecter un époxy optique dans le boîtier en verre (702) ; et recouvrir une extrémité ouverte du boîtier en verre (702) ; **caractérisé en ce que** le procédé comprend en outre les étapes consistant à :
- injecter un époxy optique dans un deuxième boîtier (500) ;
- insérer dans le deuxième boîtier (500) le boîtier en verre (702) contenant le circuit (101) ; et recouvrir une extrémité ouverte du deuxième boîtier (500).
9. Procédé selon la revendication 8, dans lequel le deuxième boîtier (500) comprend ou consiste essentiellement en du PMMA.
10. Procédé selon la revendication 8 ou la revendication 9, comprenant en outre l'étape consistant à encastrier le circuit (101) à l'intérieur d'une brique d'époxy (502) avant de placer le circuit (101) dans le boîtier en verre (702).
11. Procédé selon l'une quelconque des revendications 8 à 10, dans lequel le circuit (101) est inséré dans le boîtier en verre (702) après que l'époxy optique est injecté dans le boîtier en verre (702).
12. Procédé selon l'une quelconque des revendications 8 à 10, dans lequel le circuit (101) est inséré dans le boîtier en verre (702) avant que l'époxy optique soit injecté dans le boîtier en verre (702).
13. Procédé selon l'une quelconque des revendications 8 à 12, dans lequel l'étape consistant à recouvrir une extrémité ouverte du boîtier en verre (702) comprend l'étape consistant à insérer une boule en verre (704) au moins partiellement dans ladite extrémité ouverte du boîtier en verre (702).
14. Procédé selon l'une quelconque des revendications 8 à 13, comprenant en outre l'étape consistant à durcir l'époxy optique contenu dans le boîtier en verre (702) avant d'insérer le boîtier en verre (702) dans le deuxième boîtier (500).
15. Procédé selon la revendication 14, dans lequel l'étape consistant à durcir l'époxy optique comprend l'étape consistant à placer le boîtier en verre (702) contenant l'époxy optique et le circuit (101) dans un récipient sous pression et à augmenter la température et la pression à l'intérieur du récipient.
16. Procédé selon l'une quelconque des revendications 8 à 13, comprenant en outre l'étape consistant à durcir l'époxy optique contenu dans le boîtier en verre (702) après avoir inséré le boîtier en verre (702) dans le deuxième boîtier (500).
17. Procédé selon l'une quelconque des revendications 8 à 16, dans lequel l'époxy optique comprend des monomères MMA et des polymères PMMA pré-polymérisés.

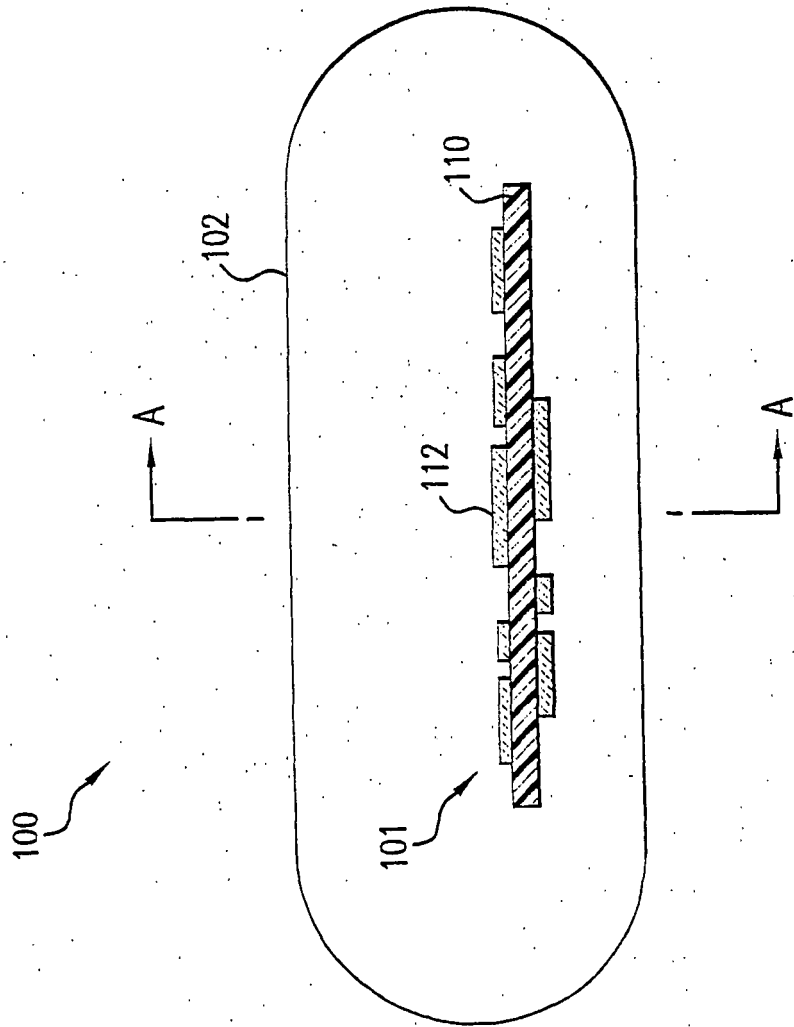

FIG.1

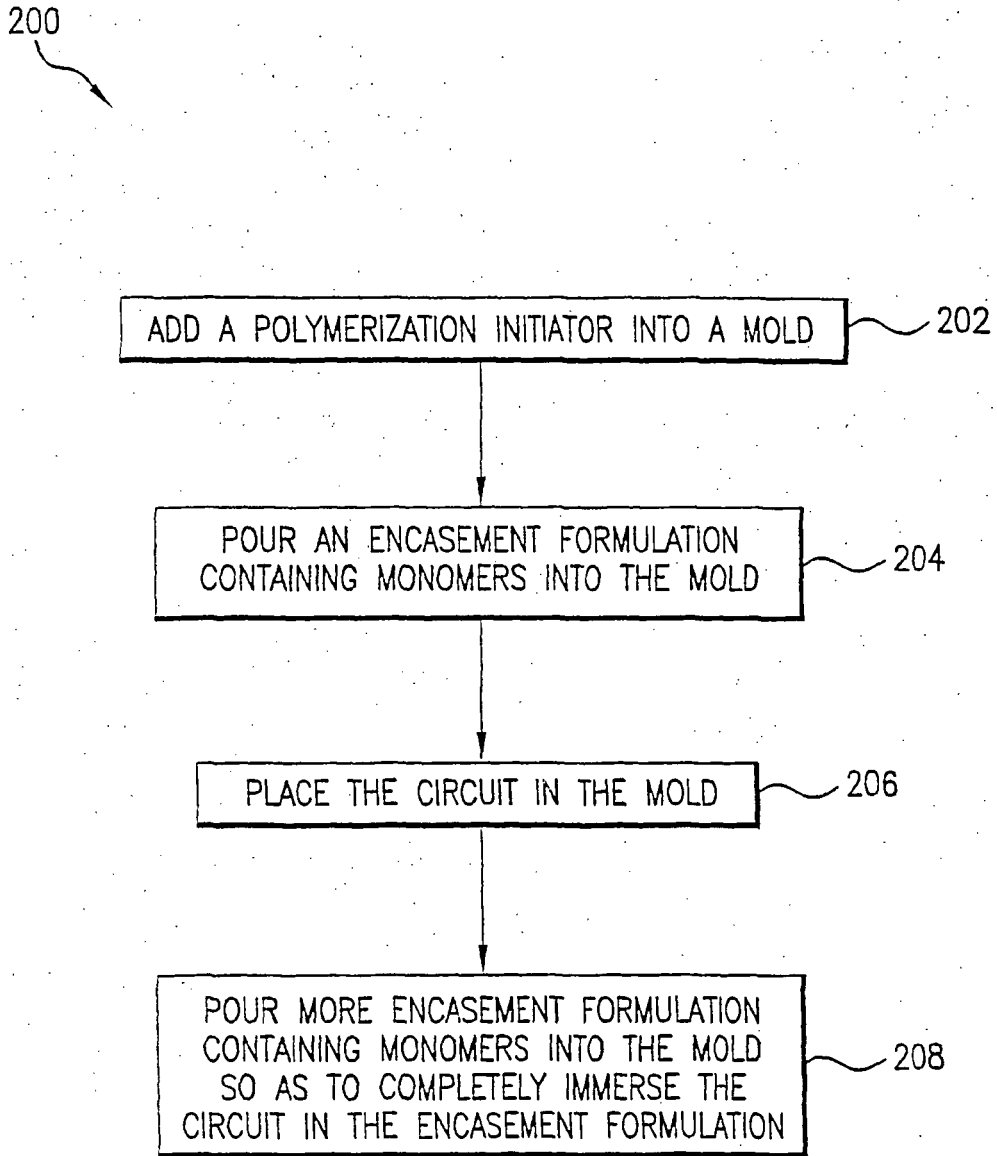

FIG.2

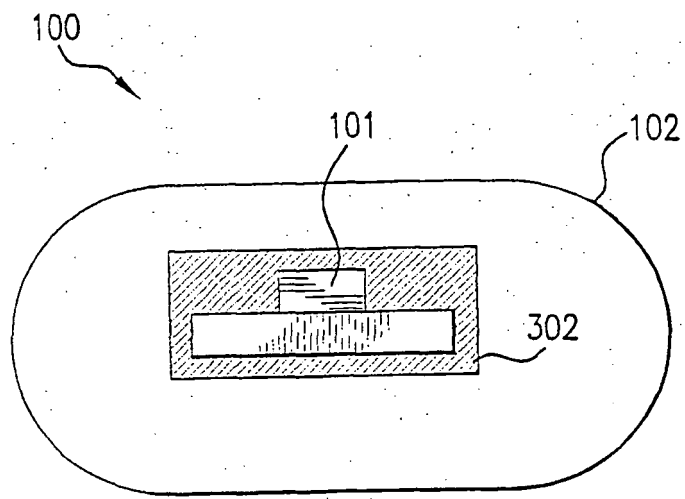

FIG. 3

400

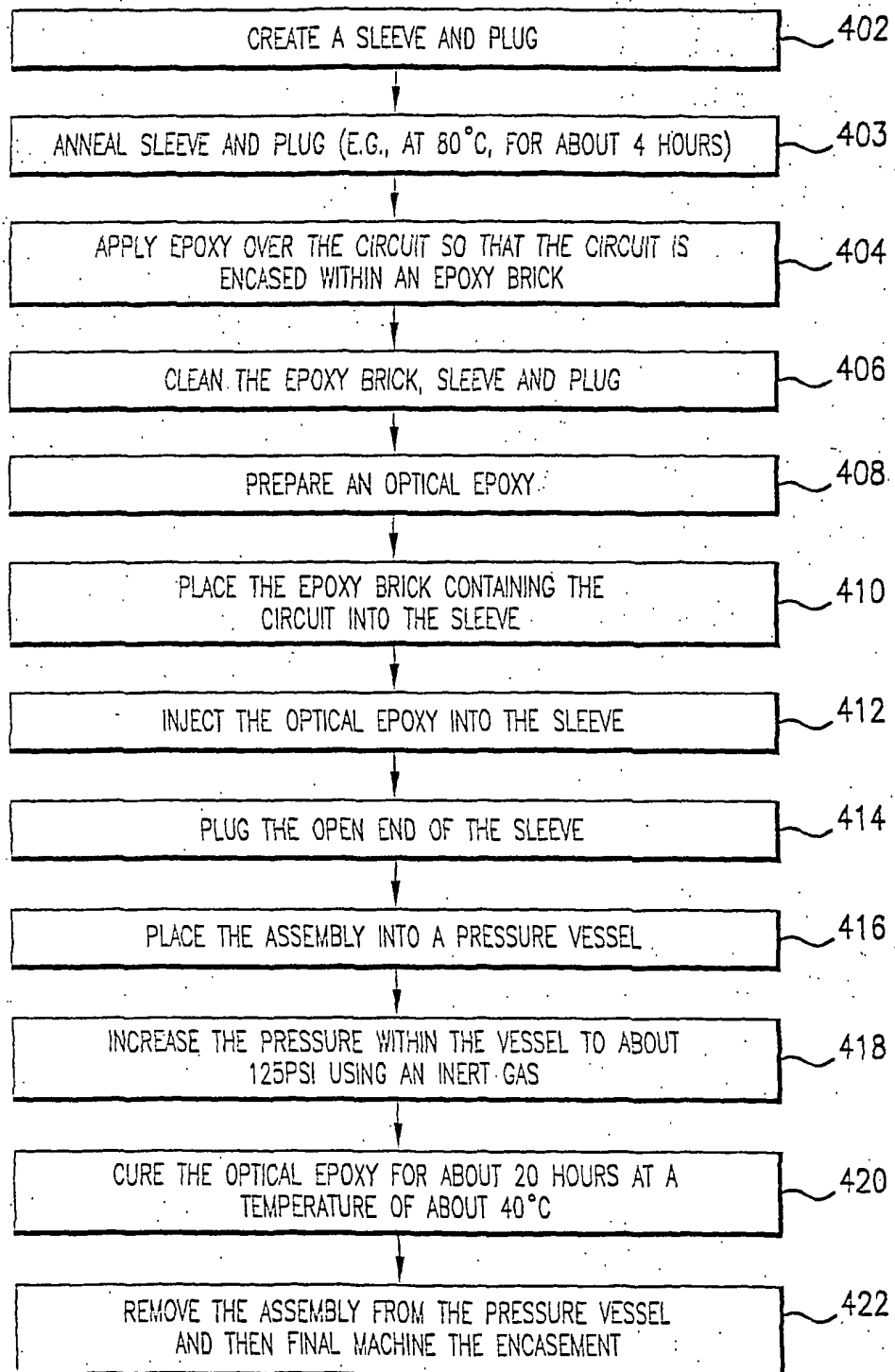

FIG. 4

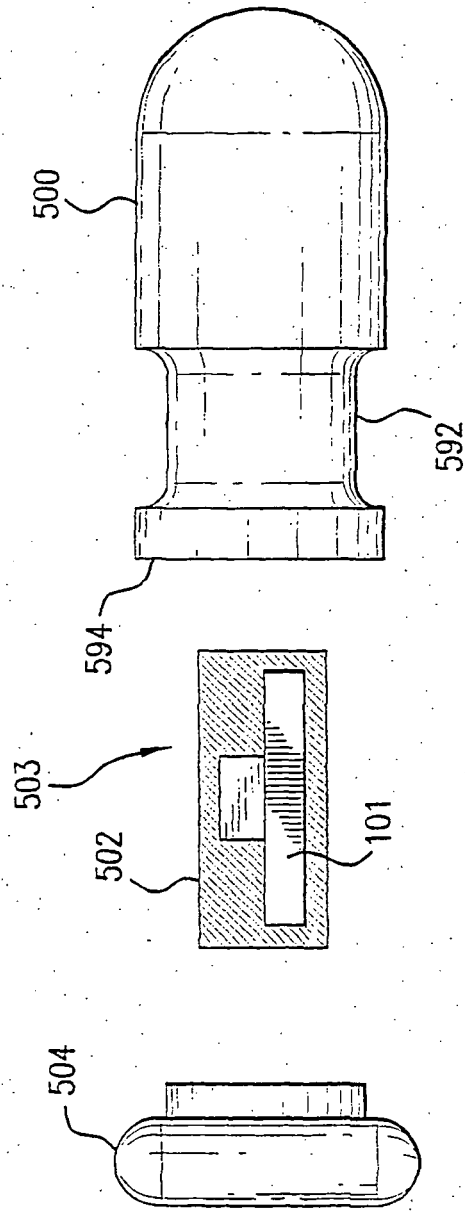

FIG. 5

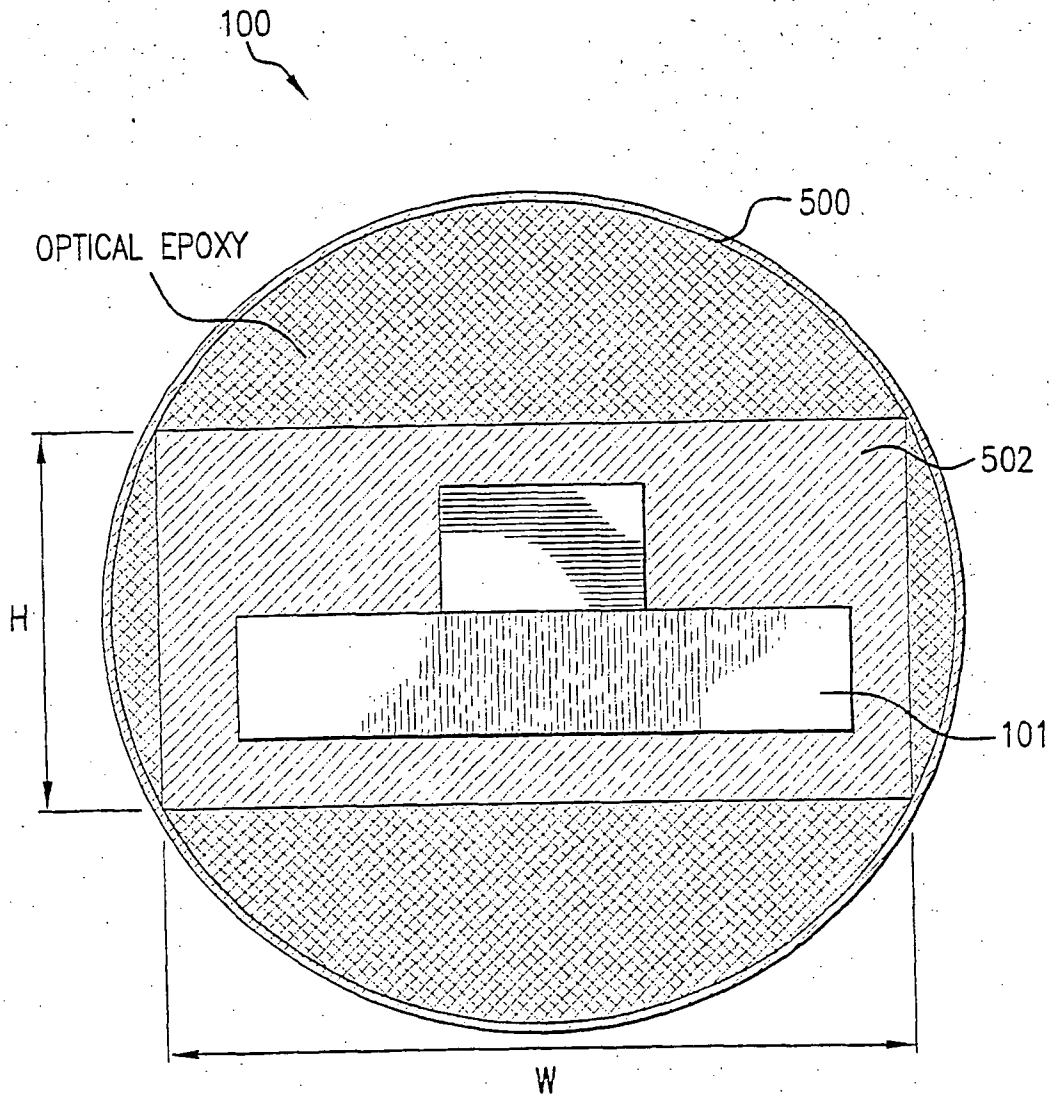

FIG. 6

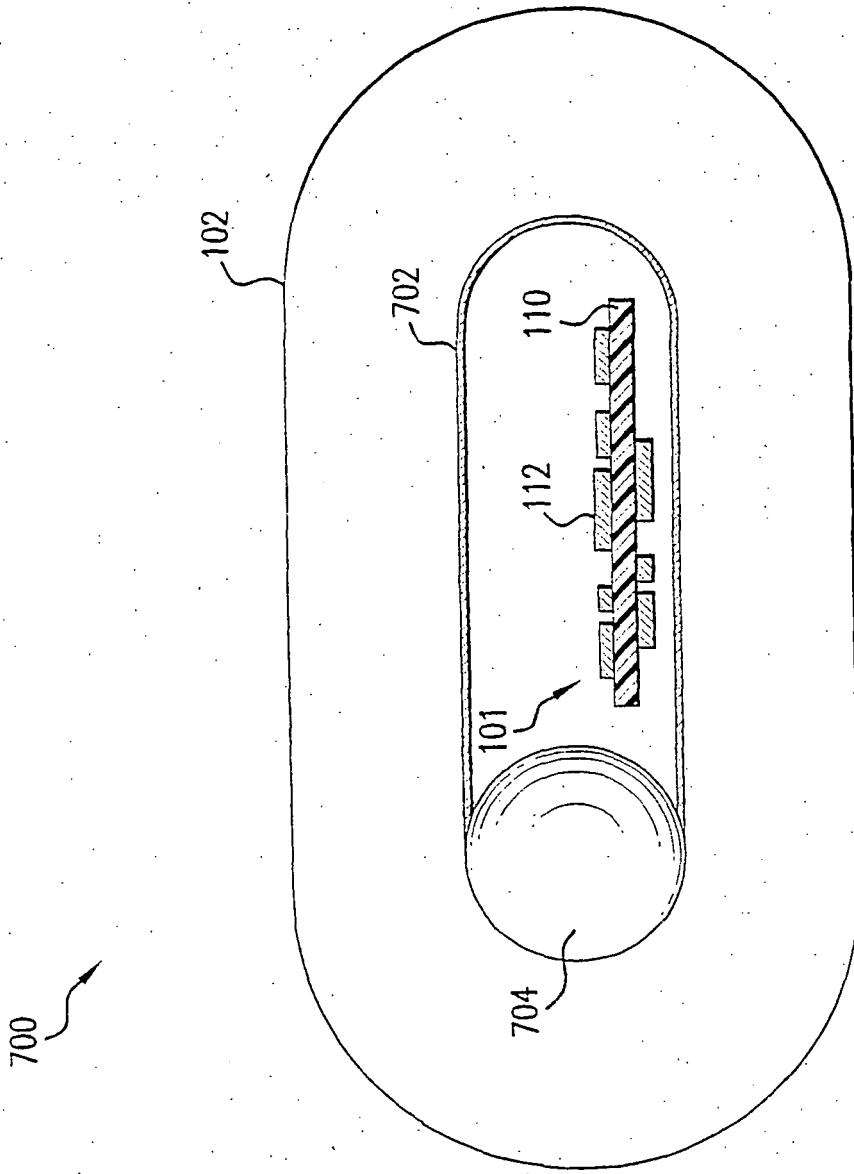

FIG.7

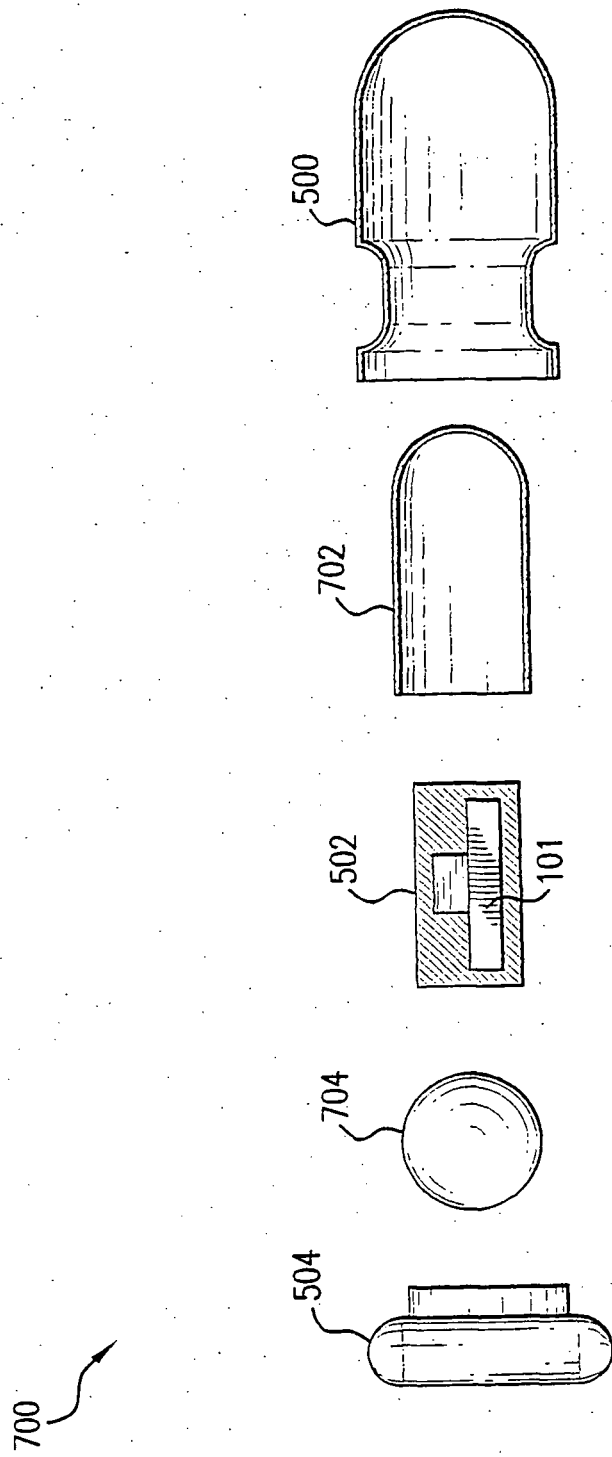

FIG.8

900

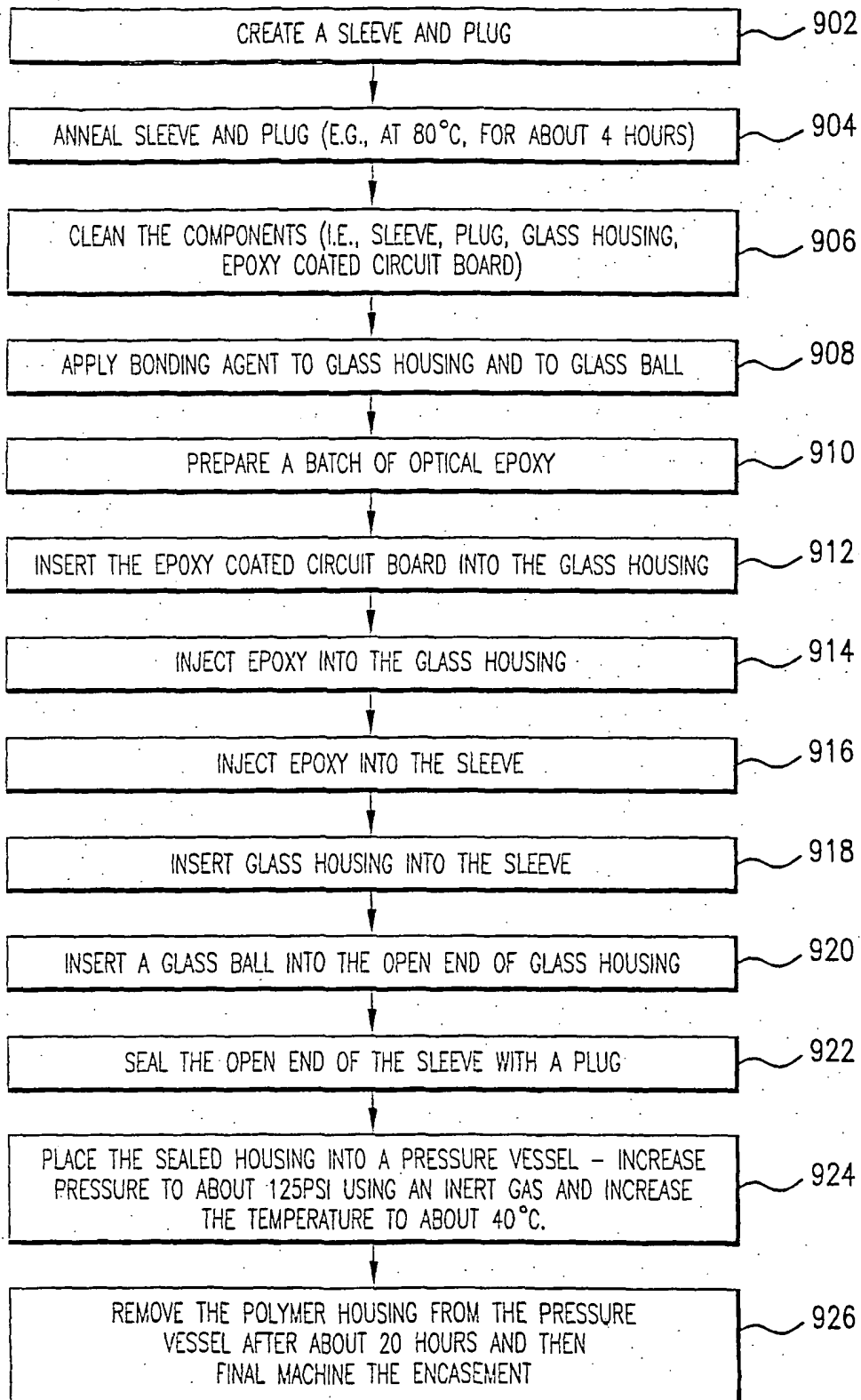

FIG.9

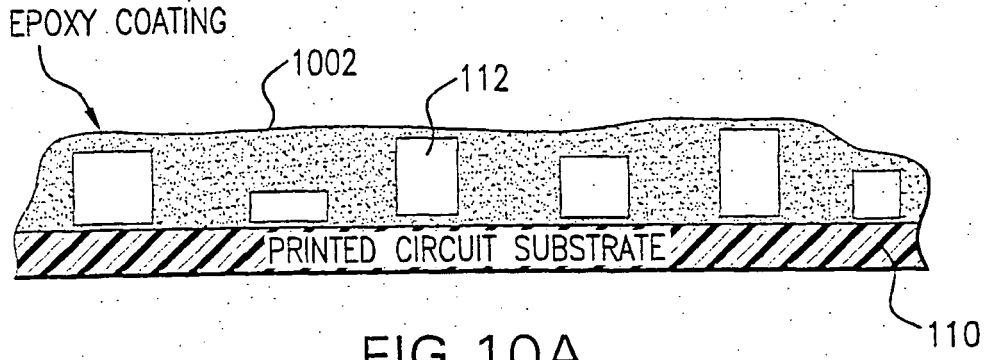

FIG. 10A

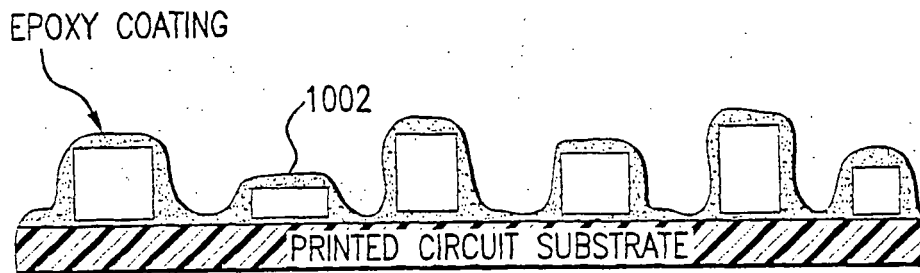

FIG. 10B

REFERENCES CITED IN THE DESCRIPTION

This list of references cited by the applicant is for the reader's convenience only. It does not form part of the European patent document. Even though great care has been taken in compiling the references, errors or omissions cannot be excluded and the EPO disclaims all liability in this regard.

Patent documents cited in the description

- US 6330464 B [0002]
- US 2003181794 A [0004]
- US 6304766 B [0019]

专利名称(译)	用于体内植入的电路的壳体及其制造方法		
公开(公告)号	EP1736041B1	公开(公告)日	2013-06-12
申请号	EP2005731370	申请日	2005-04-07
[标]申请(专利权)人(译)	医药及科学传感器公司		
申请(专利权)人(译)	医学和科学传感器公司		
当前申请(专利权)人(译)	SENSEONICS注册成立		
[标]发明人	COLVIN JR ARTHUR E LORENZ CARRIE R OCONNOR CASEY J WALTERS STEVEN J		
发明人	COLVIN, JR, ARTHUR E. LORENZ, CARRIE R. O'CONNOR, CASEY J. WALTERS, STEVEN J.		
IPC分类号	H05K5/06 A61B5/00 A61B5/07 H05K5/00		
CPC分类号	A61B5/0031 H05K5/065		
优先权	10/825648 2004-04-16 US		
其他公开文献	EP1736041A1		
外部链接	Espacenet		

摘要(译)

本发明提供了一种生物相容性电路组件，其包括封装在壳体内部的电路。在一些实施例中，壳体是PMMA壳体，并且在电路封闭在壳体内之前，电路被封装在环氧树脂砖内。

