

(19)



(11)

**EP 1 694 197 B1**

(12)

**EUROPEAN PATENT SPECIFICATION**

(45) Date of publication and mention of the grant of the patent:  
**02.11.2011 Bulletin 2011/44**

(51) Int Cl.:  
**A61B 5/00 (2006.01) A61B 5/05 (2006.01)**

(21) Application number: **04709566.6**

(86) International application number:  
**PCT/CH2004/000077**

(22) Date of filing: **10.02.2004**

(87) International publication number:  
**WO 2005/053523 (16.06.2005 Gazette 2005/24)**

(54) **A DEVICE AND METHOD FOR MEASURING A PROPERTY OF LIVING TISSUE**

VORRICHTUNG UND VERFAHREN ZUR MESSUNG EINER EIGENSCHAFT VON LEBENDEM GEWEBE

DISPOSITIF ET PROCEDE DE MESURE D'UNE PROPRIETE DE TISSUS VIVANTS

(84) Designated Contracting States:  
**AT BE BG CH CY CZ DE DK EE ES FI FR GB GR HU IE IT LI LU MC NL PT RO SE SI SK TR**

- **TRUFFER, Pascal**  
**CH-8049 Zürich (CH)**
- **HIRT, Etienne**  
**CH-6330 Cham (CH)**
- **STALDER, Gianluca**  
**CH-8489 Wildberg (CH)**

(30) Priority: **02.12.2003 PCT/CH03/00795**

(43) Date of publication of application:  
**30.08.2006 Bulletin 2006/35**

(74) Representative: **Sutter, Kurt et al**  
**E. Blum & Co. AG**  
**Vorderberg 11**  
**8044 Zürich (CH)**

(73) Proprietor: **Solianis Holding AG**  
**6300 Zug (CH)**

- (72) Inventors:
- **CADUFF, Andreas**  
**CH-8005 Zürich (CH)**
  - **BUSCHOR, Stephan**  
**CH-8052 Zürich (CH)**

(56) References cited:  
**WO-A-02/069791 GB-A- 2 055 206**  
**US-A- 5 792 668 US-B1- 6 565 509**

**EP 1 694 197 B1**

Note: Within nine months of the publication of the mention of the grant of the European patent in the European Patent Bulletin, any person may give notice to the European Patent Office of opposition to that patent, in accordance with the Implementing Regulations. Notice of opposition shall not be deemed to have been filed until the opposition fee has been paid. (Art. 99(1) European Patent Convention).

**Description**

**[0001]** This application claims the priority of international patent application PCT/CH03/00795, filed 2 December 2003.

5 Technical Field

**[0002]** The invention relates to a device for measuring a property of living tissue, in particular the glucose level of the tissue, and a method for doing the same.

10 Background Art

**[0003]** It has been known that the glucose level in living tissue can be measured non-invasively by applying an electrode arrangement to the skin of a patient and measuring the response of the electrode arrangement to a suitable electric signal. Such a technique is described in WO 02/069791.

15 **[0004]** This type of device is equipped with an electrode arrangement for being applied to the specimen and a voltage-controlled oscillator as a signal source for generating an AC voltage in a given frequency range. The AC voltage is applied to the electrode arrangement. The response of the electrode arrangement, such as a voltage over the electrode arrangement depending on the dielectric properties of the tissue, is fed to a processing circuitry.

20 **[0005]** Even though this device is well able to monitor glucose, it needs careful calibration and must be operated under well-defined conditions in order to yield results of high accuracy.

**[0006]** The device of WO 02/069791 is one example of a device for measuring a parameter of living tissue. Similar types of devices can be used to measure other properties of the tissue that affect its response to an electric AC field, such as its dielectric constant, or an ion concentration.

25 **[0007]** Devices of this type should have high accuracy. In addition, in portable devices, low power consumption and low power supply voltages are desired.

Disclosure of the Invention

30 **[0008]** Hence, in a first aspect of the invention, it is an object to provide a device of this type with high physiological compatibility.

**[0009]** Now, in order to implement this and still further objects of the invention, which will become more readily apparent as the description proceeds, a device according to claim 1 is used.

35 **[0010]** In the device according to a preferred aspect of the invention, the voltage-controlled oscillator (VCO) comprises at least one voltage-controlled amplifier the gain of which can be set by a gain control signal. The VCO further comprises at least one tank circuit with a voltage-controlled capacitor determining a frequency of operation of the VCO. The device is adapted to control the gain control signal for increasing the gain when the DC-voltage over the voltage-controlled capacitor(s) is close to zero.

40 **[0011]** This makes it possible to operate the voltage-controlled capacitor with DC-voltages close to zero where its loss becomes high, thereby allowing to generate a wide range of frequencies with an only a moderate supply voltage and power consumption.

**[0012]** In a second preferred aspect of the invention, it is an object of the invention to provide a device of the type mentioned above that allows an accurate measurement with simple circuitry.

**[0013]** This second aspect is achieved with the device of claim 8.

45 **[0014]** In a device according to this aspect, the processing circuitry comprises at least one diode for rectifying an AC input voltage and generating a rectified signal as well as an integrator for smoothing the same. The rectified, smoothed signal (or a signal derived therefrom) is fed to an A/D-converter and converted to a digital value. This digital value will depend on, but not be proportional to, the AC amplitude of the input voltage. Hence, it is converted to a signal value substantially proportional to the AC amplitude of the input voltage, e.g. by means of a calibration function or a lookup table. The wording "substantially proportional" is to designate that the signal value is more proportional to the AC amplitude than the digital value and can be used, at least in approximation, for calculations that require values exactly proportional to the AC amplitude.

**[0015]** In this manner, the analog circuitry is simplified without loss of accuracy. In particular, the analogue circuitry does not need to provide a signal that is exactly proportional to the AC amplitude of the input voltage.

55 **[0016]** In an other preferred aspect of the invention, it is an object of the invention to provide a device of the type mentioned above that allow an accurate measurement that efficiently exploits the available data.

**[0017]** This aspect is achieved with the device of claim 15.

**[0018]** In this aspect of the invention, an AC voltage of a series of frequencies  $f_i$  is generated and applied to the specimen via the electrode arrangement. A corresponding series of measurement values  $m_i$  at each of the frequencies

$f_i$  is determined. Each measurement value  $m_i$  depends on dielectric properties of the specimen at the corresponding frequency. A function  $M(f, b_0, \dots, b_K)$  with parameters  $b_1$  to  $b_K$  is fitted to the measurement values  $m_i$  at their given frequencies  $f_i$ , or through values derived therefrom, thus determining the parameters  $b_1$  to  $b_K$ . At least part of the parameters  $b_1$  to  $b_K$  can then be used for determining the desired property, e.g. using calibration data from earlier calibration measurements.

**[0019]** Since the involved fitting process exploits information from all used measurement values and inherently compensates for the effects of statistical fluctuations, the results obtained in this way have good accuracy.

**[0020]** In an other preferred aspect of the invention, it is an object to provide a device of the type mentioned above that allows an accurate measurement.

**[0021]** This aspect is achieved with the device of claim 20.

**[0022]** This aspect is based on the finding that an asymmetric design of the outer electrode provides a stronger, more reliable signal.

**[0023]** The object of the present invention is achieved by the device of claim 1, where all through-contacts to the electrodes are covered with a biologically inert material. It has been found that through-contacts are a general source of noxious or allergenic substances. Hence, by covering the through-contacts, the biocompatibility of the device can be increased.

**[0024]** It must be noted that the features of the devices according to the various aspects can be used individually or in combination.

#### Brief Description of the Drawings

**[0025]** The invention will be better understood and objects other than those set forth above will become apparent when consideration is given to the following detailed description thereof. Such description makes reference to the annexed drawings, wherein:

Fig. 1 is a cross section of a device for measuring a glucose level,

Fig. 2 is a block circuit diagram of the device of Fig. 1,

Fig. 3 is a circuit diagram of an advantageous embodiment of a voltage-controlled oscillator,

Fig. 4 is a circuit diagram of an advantageous embodiment of a measuring circuit,

Fig. 5 is the dependence of the digital value at output o1 on the AC amplitude at input u1,

Fig. 6 shows a typical series of measurement values  $m_i$  (dots) and a curve fitted through the values, Fig. 7 a bottom view of the device of Fig. 1,

#### Modes for Carrying Out the Invention

**[0026]** Basic setup of the device:

Fig. 1 shows a cross section of a device 100 for measuring a subjects's glucose level. It must be noted, though, that the same type of device can be measure any other parameter of living tissue that affects the response of the tissue to an applied electric AC field as mentioned above. Apart from the glucose level, such a property can e.g. be an electrolyte level of the tissue.

**[0027]** The device of Fig. 1 comprises a housing 1 closed on one side by an electrode plate 2. A display 3 is located opposite electrode plate 2. Electronic circuitry is arranged between electrode plate 2 and display 3.

**[0028]** Electrode plate 2 comprises a flat, electrically insulating substrate 4. A strip electrode 5 covered by an insulating layer 5a and an outer, annular electrode 6, which encloses strip electrode 5 at least partially or fully, are arranged on an outer side 7 of insulating substrate 4. An inner side 8 of insulating substrate 4 is covered by a ground electrode 9. A plurality of through-contacts 10 connect outer electrode 6 to ground electrode 9. A further through-contact 11 connects one end of strip electrode 5 to a contact pad 12 arranged on inner side 8.

**[0029]** A first temperature sensor 15 is mounted to ground electrode 9 in direct thermal contact thereto. The large number of through-contacts 10 ensures that ground electrode 9 closely follows the temperature of outer electrode 6 and therefore the temperature of the specimen, the surface of which is indicated by a dotted line 16.

**[0030]** Leads or springs 18 are provided to connect ground electrode 9, contact pad 12 and first temperature sensor 15 to the electronic circuitry arranged on a printed circuit board 19 forming an assembly of electronic components. Printed circuit board 19 is advantageously arranged on a side of the device that is substantially opposite to the side of electrode plate 2. A battery 21 for powering the circuitry is arranged between printed circuit board 19 and electrode plate 2.

**[0031]** A second temperature sensor 22 is arranged on printed circuit board 19 and in direct thermal contact thereto.

**[0032]** The circuitry of device 100 can be the one described in WO 02/069791. An other possible circuit is, however,

shown in the block circuit diagram of Fig. 2. It comprises a voltage-controlled oscillator (VCO) 31 as a signal source for generating a sine wave signal  $V_{VCO}$  or another periodic signal of selectable frequency  $\omega$ . This signal is fed to an amplifier 32, the output of which is connected via a resistor R1 to a signal point 34 and to a first input u1 of a measuring circuit 37. In addition, the output of amplifier 32 is fed directly to a second input u2 of measuring circuit 37. A resonant circuit 35 comprising an inductance L and a capacitor C in series is connected between signal point 34 and ground.

**[0033]** The operation of measuring circuit 37 will be further described below. Its output, which is e.g. the amplitudes and/or relative phase of the AC-voltages at inputs u1 and u2, is fed to a microprocessor 38, which also controls the operation of VCO 31.

**[0034]** Microprocessor 38 further samples the first and second temperature signals T1, T2 from first and second temperature sensors 15, 22. It also controls display device 3, an input device 40 with user operable controls, and an interface 41 to an external computer. A memory 42 is provided for storing calibration parameters, measurement results, further data as well as firmware for microprocessor 38. At least part of memory 42 is non-volatile.

**[0035]** Inductance L of the device of Fig. 2 can be generated by a coil and/or by the leads and electrodes of capacitor C. Its value is generally known with reasonable accuracy.

**[0036]** Capacitor C of the device of Fig. 2 is formed between strip electrode 5 and outer electrode 6 and is used for probing the specimen. For this purpose, the electrodes are arranged on the skin 16 of the subject as shown in Fig. 1.

**[0037]** For a good and permanent contact with the subject's skin, the device is advantageously worn on an arm or leg and provided with a suitable holder or wrist band 43.

**[0038]** In summary, the device shown in Figs. 1 and 2 comprises:

- a voltage-controlled oscillator for generating an AC voltage in a given frequency range,
- an electrode arrangement comprising the electrodes 5 and 6,
- processing circuitry including the elements 31 - 33, 37, 38 for measuring the response of the electrode arrangement to an electrical signal and deriving the glucose level or some other parameter therefrom.

**[0039]** In addition, it can comprise at least two temperature sensors 15, 22, the signals of which depend in different manner on the skin temperature of the body and on the environmental temperature. One or, advantageously, both these temperatures can be taken into account when determining the glucose level.

**[0040]** Method of operation:

The basic principle of operation of the device is described in WO 02/069791.

**[0041]** To measure the concentration of glucose in the body fluid of the patient, microprocessor 38 can e.g. initiate a measurement cycle consisting of a frequency sweep of VCO 1. The sweep should start at a frequency  $f_{max}$  above the expected resonance frequency  $f_0$  of the resonant circuit 35 and extend to a frequency  $f_{min}$  below resonance frequency  $f_0$  (or vice versa). During this sweep, the electrical properties of the resonant circuit will change. The amplitude determined by measuring circuit A will fall to a minimum  $A_0$  at a characteristic frequency  $f_0$ , as described in WO 02/069791. Similarly, the phase shift  $\phi$  will cross zero.

**[0042]** Microprocessor 38 measures  $A_0$  and/or  $f_0$ , or some other parameter(s) descriptive of the frequency response of the device, as input values describing the physiological state of the subject's blood, bodyliquids and tissue. In addition to the input values of  $A_0$  and/or  $f_0$ , microprocessor 38 measures the temperature values T1 and T2 as further input values. Using suitable calibration data, the glucose level can be derived from these input values.

**[0043]** Such calibration data can be determined from calibration measurements over a range of input values in straightforward manner using methods known to the person skilled in the art.

**[0044]** In general, microprocessor 38 will use a formula of the type

$$g = F(s_1, s_2, \dots, s_N, a_0, a_1, \dots, a_M) \quad (1)$$

for determining the glucose level g (or a parameter indicative thereof) from N measured input values  $s_1, s_2, \dots, s_N$  ( $N > 0$ ), where the function F has M+1 parameters  $a_0, a_1, \dots, a_M$  ( $M \geq 0$ ), at least some of which have to be determined in the calibration measurements.

**[0045]** The measured input values  $s_i$  are e.g. values directly or indirectly derived from the amplitude  $A_0$ , the corresponding frequency  $f_0$ , and the temperatures T1, T2. The input values can e.g. be the most recent values measured or they can be a time average or a median over a given number of recent measurements. Possible input values are

discussed in the section "Further processing of the raw signals" below.

**[0046]** The function F can be empirical or it can be based at least partially on a model describing the physical nature of the mechanisms involved.

**[0047]** Assuming that the relation between the glucose level g and the measured values  $s_i$  is linear at least on approximation, we have

$$g = a_0 + a_1 \cdot s_1 + a_2 \cdot s_2 + \dots + a_N \cdot s_N \quad (2a)$$

with  $M = N$ .

**[0048]** Equation (2a) has the advantage of being linear in the input values  $s_i$  as well as the parameters  $a_j$ , which simplifies calibration as well as evaluation. More refined models can, however, be used as well.

**[0049]** In order to determine the parameters  $a_0, a_1 \dots a_N$ , a series of at least  $N+1$  calibration measurements has to be carried out, each calibration measurement comprising a determination of the input values  $s_j$  and a reference glucose level g measured by conventional means, e.g. an invasive method.

**[0050]** In a most simple approach, the parameters  $a_i$  can then be obtained from a conventional least-squares fitting algorithm that varies the parameters  $a_i$  in order to find a best match of equations (2) or (2a) to the calibration measurements. Suitable algorithms are known to a person skilled in the art and are e.g. described by Press, Teukolsky, Vetterling and Flannery in "Numerical Recipes in C", Cambridge University Press, 2<sup>nd</sup> edition, 1992, Chapter 15.

**[0051]** Once the parameters  $a_i$  are known, the glucose level g can be determined from equations (2) or (2a) based on the measurement of the input values  $s_j$ .

**[0052]** Re-calibration of at least part of the parameters may be advisable at regular intervals or after a displacement of device 100 in respect to the specimen.

**[0053]** In the following, various advantageous aspects of the present device are described in more detail.

**[0054]** Voltage-controlled oscillator:

In principle, various designs of voltage-controlled oscillators are suited for being used in the present device, such as the one shown in Fig. 9 of WO 02/069791. In the following, though, an advantageous embodiment of a voltage-controlled oscillator is described, which operates with low supply voltage, has low power consumption, can oscillate in a large frequency range and generates sine-wave signals with only little distortions.

**[0055]** The voltage-controlled oscillator 31 of Fig. 3 comprises two symmetric tank circuits with inductances L1 and L2 and voltage-controlled capacitors (varactor diodes) D1, D2, respectively. The capacitance of the voltage-controlled capacitors D1, D2 is controlled by a frequency control voltage or frequency control signal V1. In addition, VCO 31 comprises two amplifiers each consisting of a dual-gate FET T1, T2. The gain of transistors T1, T2 is controlled by a gain control voltage or gain control signal V2. The components L1, D1, L2, D2 and T1, T2 are connected to oscillate at the resonant frequency of the tank circuits such that the voltages at the drains of T1, T2 are 180° out of phase. The drains of transistors T1, T2 and therefore the amplifier outputs are interconnected through capacitors C1, C2 and the primary winding of a transformer TR. The secondary winding of transformer TR generates the output voltage  $V_{VCO}$  in respect to analog ground AGND (which lies approximately at 2.5 Volts).

**[0056]** The frequency of VCO 31 can be selected via frequency control voltage V1, which can e.g. be generated by microprocessor 38. Typically, frequency control voltage V1 ranges between -10 and +5 Volts. However, when coming close to +5 Volts, the DC-voltage over D1 and D2 decreases and therefore the losses in D1 D2 increase. To compensate for these losses, the gain of the amplifiers is adjusted depending on the value of frequency control voltage V1, by increasing gain control voltage V2 and therefore the amplifier gain when the DC-voltage over voltage-controlled capacitors D1, D2 is close to 0.

**[0057]** Gain control voltage V2 may be generated by microprocessor 38. For example, microprocessor 38 can access calibration data in RAM/ROM 42 that gives, for each value of frequency control voltage V1, a suitable value of gain control voltage V2 or of a derivative thereof.

**[0058]** Advantageously, gain control voltage V2 is generated by a feedback loop that monitors the amplitude of output voltage  $V_{VCO}$  or the signal at second input  $u_2$  of measuring circuit 37 and controls gain control voltage V2 to keep the amplitude constant. This will again lead to an increase in gain control voltage V2 when the DC-voltage over voltage-controlled capacitors D1, D2 comes close to 0.

**[0059]** Controlling voltage V2 in a feedback loop has the advantage that the output voltage is kept substantially constant even if the operating parameters of VCO 31 vary e.g. depending on temperature and/or circuit age. This is particularly important if measuring circuit 37 is designed for optimum performance over a certain voltage range only, and it ensures that nonlinearities of the response of the body to the applied electric field do not affect the measured signals.

**[0060]** The feedback loop for controlling V2 can be implemented using analog circuitry or with the aid of microprocessor 38. Using microprocessor 38 is advantageous because the circuit design is simplified. However, care must be taken that the implementation of the feedback loop does not unnecessarily increase the power consumption of the device.

**[0061]** Hence, an advantageous implementation of the feedback loop should avoid unnecessarily long operation of the VCO in order to find an appropriate value of V2. As mentioned above, microprocessor 38 can initiate a measurement cycle consisting of a frequency sweep of VCO 31. The sweep e.g. starts at a frequency  $f_{\max}$  and extends to a frequency  $f_{\min}$  and consists of repetitive measurements at a given series of frequencies  $f_i$ . In an advantageous embodiment, RAM/ROM 42 holds calibration data that allows to calculate, for each frequency  $f_i$ , the derivative  $d(f_i) = dV2/df|_{f=f_i}$ . Using this data, the following steps are taken to control the value of voltage V2:

- In the first measurement cycle at frequency  $f_1 = f_{\max}$ , the value of V2 is varied by microprocessor 38 until voltage  $u_2$  is at a given value  $u_{2\text{opt}}$  of e.g. 500 mV. The corresponding value of V2 is  $V2(f_1)$ .
- In the second measurement cycle, the value of  $V2(f_2)$  is calculated from  $V2(f_1)$  by linear extrapolation using the derivative  $d(f_1)$  (or  $d(f_2)$  or a value between  $d(f_1)$  and  $d(f_2)$ ), e.g.  $V2(f_2) = V2(f_1) + (f_1 - f_2) \cdot d(f_1)$ .
- In subsequent measurement cycles,  $V2(f_{i+1})$  is calculated again by linear extrapolation from  $V2(f_i)$ , but the linearly extrapolated value is corrected by a correction, the value of which depends on if voltage  $u_2$  at frequency  $f_i$  was above or below the desired value  $u_{2\text{opt}}$ . If voltage  $u_2$  at frequency  $f_i$  was above  $u_{2\text{opt}}$ , the correction of  $V2(f_{i+1})$  is aimed to decrease voltage  $u_2$  at frequency  $f_{i+1}$  and vice versa. For example, the relation  $V2(f_{i+1}) = V2(f_i) + k \cdot (f_i - f_{i+1}) \cdot d(f_i)$  can be used for  $k$  either being 9/8 or 7/8 depending on the comparison of  $u_2$  with  $u_{2\text{opt}}$  at frequency  $f_i$ , or  $V2(f_{i+1}) = k' \cdot (V2(f_i) + (f_i - f_{i+1}) \cdot d(f_i))$  with  $k'$  being slightly above or below 1. This ensures that voltage  $u_2$  remains within a certain range around its optimum value  $u_{2\text{opt}}$ .

**[0062]** Hence, in general, in at least some of the measurement cycles  $i$ , a comparison of the output voltage of VCO 31 (or, equivalently, a voltage derived therefrom, such as voltage  $u_2$ ) with an optimum value ( $u_{2\text{opt}}$ ) is carried out. The voltage V2 of a next measurement cycle  $i+1$  is then corrected depending on the result of the comparison.

**[0063]** Instead of, or in combination with, a feedback loop for voltage V2, RAM/ROM 42 can hold temperature dependent calibration data for calculating a suitable value of voltage V2 at different frequencies and temperatures, and the temperature measured by temperature sensor 22 can be used to select the appropriate calibration data.

**[0064]** The symmetric design of VCO 31 with two amplifiers T1 and T2 and two tank circuits L1, D1 and L2, D2 operating at a phase shift of  $180^\circ$  and the fact that the output voltage  $V_{\text{VCO}}$  is derived from the voltage drop over the outputs of the amplifiers lead to a sine signal with very low distortions. This is of particular importance if the device is to operate over a frequency range of more than 1:2. Depending on the design of measuring circuit 37, higher harmonics would otherwise give rise to additional signals leading to erroneous results.

**[0065]** A typical frequency range of the voltage-controlled oscillator as shown in Fig. 3 is 20 to 60 MHz for a frequency control voltage V1 of +5 to -10 Volts. The value of gain control voltage V2 is chosen to be approximately +4 Volts for V1 close to +5 Volts and +3 Volts for V1 much smaller than +5 Volts.

**[0066]** As can be seen from Fig. 3, both control voltages are smoothed by capacitors C3, C4, which act as filters to block any frequencies in the operating range of VCO 31, thereby making the oscillator signal more sinusoidal. For the same purpose, the gates connected to gain control voltage V2 are connected to the sources of the FETs by means of a filter capacitor C5. In addition, and again for the same purpose, the resistor R1 connected between 0V and the sources of transistors T1, T2 and acting as an approximate current source is arranged parallel to a capacitor C6, which again suppresses any oscillations of the resistor voltage at the range of frequencies of VCO 31.

**[0067]** Measuring circuit 37:

In general, measuring circuit 37 can be any circuit that is able to measure the absolute or relative AC amplitudes of the signals at the inputs  $u_1$  and  $u_2$ .

**[0068]** An advantageous embodiment of the measuring circuit is shown in Fig. 4. It comprises two identical channels for processing the signals at the two inputs  $u_1, u_2$ . In the following, therefore, only the first channel for input  $u_1$  is discussed.

**[0069]** The signal at first input  $u_1$  is fed to an amplifier A10, the output of which is applied to two diodes D10, D11. Each diode generates a rectified signal at point P10 or P11, respectively. The rectified signal is connected to a capacitor C10 or C11 and a resistor R10 or R11, respectively, which act as an integrator or low pass filter and only pass frequencies much lower than the oscillator frequency  $f$ , thereby smoothing the rectified signals. Upper diode D10 is in series to upper filter C10, R10, and upper filter C10, R10 is connected to a first voltage (e.g. +5V). They generate a voltage at point P10 that depends on the minimum value of the AC signal. Lower diode D11 is in series to lower filter C11, R11, and lower filter C11, R11 is connected to a second voltage (e.g. 0V). The second voltage is lower than the first voltage. They generate a voltage at point P11 that depends on the maximum value of the AC signal.

**[0070]** Assuming that the voltage at input  $u_1$  is

$$U(t) = U_0 + x \cdot \sin(2\pi ft + \phi), \quad (3)$$

5 the voltage at point P10 after upper diode D10 is therefore  $k \cdot (U_0 - x) + u_d$ , wherein  $k$  is the gain of amplifier A10 and  $u_d$  is the forward voltage of diode D10 at the given frequency and temperature, while the voltage at point P11 after lower diode D11 is  $k \cdot (U_0 + x) - u_d$ .

[0071] The voltages at points P10 and P11 are fed to an instrumental amplifier A11, which yields, at its output a voltage equal to or proportional to the difference of the voltages at its input. An A/D-converter is used to convert this voltage to a digital value  $o1$ . The digital value is proportional to  $u_d - k \cdot x$  assuming that the response of all devices is linear.

10 [0072] In general, taking into account that the response of some of the elements is not linear and that some parameters of the circuit, such as the forward voltage  $u_d$ , depend on temperature  $T$ , frequency  $\omega$  and/or amplitude  $x$ , we have, for the digital value  $o1$

15

$$o1 = H(x, \omega, T), \quad (4)$$

20 where the response function  $H$  is qualitatively depicted in Fig. 5 for two different temperatures  $T$  and  $T'$ .

[0073] In a further processing step, a value proportional to the AC-amplitude  $x$  is required. Hence, microprocessor 38 is used for calculating the inverse of function  $H$ . For this purpose, the response function  $H$  can be determined in calibration measurements and its inverse can be stored as calibration data, e.g. in a table in RAM/ROM 42 for a plurality of temperatures  $T$ , frequencies  $f$  and AC amplitudes  $x$ . For each measurement, microprocessor 38 determines the digital value  $o1$  as well as the temperature  $T$  (e.g. using second temperature detector T22) and the current frequency  $\omega$  (which it knows because it controls the operation of VCO 31 by means of frequency control voltage  $V1$ ). Once the values of  $o1$ ,  $\omega$  and  $T$  are known, the value of  $x$  can be determined by interpolation from the table stored in RAM/ROM 42.

25 [0074] Instead of using a separate temperature detector T22, the temperature can also be determined from the temperature-dependent forward voltage  $u_D$  of one or both of the diodes D10, D11. For this purpose, VCO 31 is switched off, in which case the digital value  $o1$  is approximately equal to  $2 \cdot u_D$  (where  $u_D$  is the forward voltage at frequency 0 and dependent on temperature  $T$ ).

30 [0075] Instead of using two diodes D10, D11, only a single diode and its corresponding resistor C11 and R11 would suffice, in which case instrumental amplifier A11 or A21 can be dispensed with or be replaced by a simple amplifier. The circuitry of Fig. 1 has, however, the advantage of generating a twice as high signal. In addition, the asymmetric design provides a more accurate result.

35 [0076] Further processing of the raw signals:

40 For the following steps, we assume that the electrode arrangement 5, 6 is connected to the output of VCO 31 via a first non-zero impedance  $Z1$  (in the embodiment of Fig. 2, we have  $Z1 = R1$ , but  $Z1$  may also be an inductive, capacitive or mixed impedance). Hence, the voltage at the electrode arrangement 5, 6 depends on the dielectric properties of the specimen to be measured as well as on the output voltage  $V_{VCO}$  from VCO 31. The AC-voltage at input  $u1$  is derived from or equal to the voltage at the electrode arrangement 5, 6 and therefore also depends on the property of the specimen to be measured as well as, linearly, on the output voltage  $V_{VCO}$  from VCO 31.

45 [0077] The input  $u2$  is connected via a second impedance  $Z2$  to the output of VCO 31.  $Z2$  may be zero (as in the embodiment of Fig. 2) or non-zero. The AC-voltage at input  $u2$  is, at least in good approximation, not dependent on the dielectric properties of the specimen to be measured, but it does depend linearly on the output voltage  $V_{VCO}$  from VCO 31.

50 [0078] As described in WO 02/069791, a relative amplitude  $A$  between the AC voltages at inputs  $u1$  and  $u2$  is preferably used for further processing because such a relative amplitude is not dependent on the absolute amplitude of the output voltage  $V_{VCO}$  of VCO 31. This relative amplitude  $A$  is

$$A = x1/x2, \quad (5)$$

55

where  $x1$  is the AC amplitude at input  $u1$  and  $x2$  is the AC amplitude at input  $u2$ . Equivalently, the reciprocal value  $x2/x1$  can be used.

[0079] As mentioned above, microprocessor 38 can initiate a measurement cycle consisting of a frequency sweep of VCO 1. The sweep should start at a frequency  $f_{max}$  above the expected resonance frequency  $f_0$  of the resonant circuit 35 and extend to a frequency  $f_{min}$  below the resonance frequency  $f_0$ . During this frequency sweep, repetitive measurements of the values  $x_1$  and  $x_2$  are carried out at a given series of frequencies  $f_i$  using the circuitry described above. In each measurement  $i$ , at least one measurement value  $m_i$  is determined. Typically, several hundred measurements are carried out in each measurement cycle.

[0080] The measurement values  $m_i$  are, in general, a function  $g$  of one or both amplitudes  $x_1$  and  $x_2$ :

$$m_i = g(x_{1i}, x_{2i}), \quad (6)$$

where  $x_{1i}$  and  $x_{2i}$  are the values of  $x_1$  and  $x_2$  measured in measurement  $i$  at a frequency  $f_i$ . Preferably, for the reasons mentioned above,  $m_i$  should be derived from the relative amplitude  $A$  only, i.e. from the ratio of the amplitudes  $x_1$  and  $x_2$ , i.e.

$$m_i = G(x_{1i}/x_{2i}) \quad (7)$$

with  $G$  being any suitable function, including the identity function. For example, one of the following definitions for the measurement value  $m_i$  can be used

$$m_i = x_{1i}/x_{2i} - 1. \quad (8a)$$

or

$$m_i = x_{1i}/x_{2i}. \quad (8b)$$

Since the impedance of the resonant circuit 35 of Fig. 2 goes to a minimum at its resonance frequency  $f_0$ , a typical series of measurement values  $m_i$  looks as shown in Fig. 6.

[0081] Part of the input values  $s_i$  of equations (1) and (2a) are to be derived from the measurement values  $m_i$ . In a simple approach, as it is described in WO 02/069791, a possible input value is the frequency  $f_0$  where  $x_1/x_2$  is smallest and the corresponding minimum value  $A_0$ .

[0082] However, in an advantageous embodiment, the following procedure is used.

[0083] In a first step, a theoretical or empirical function  $M(f, b_0, \dots, b_k)$  with parameters  $b_1$  to  $b_k$  is fitted through the points  $m_i(f_i)$ . Suitable algorithms are known to a person skilled in the art and are e.g. described by the standard textbook of Press et al. mentioned above.

[0084] In order to reduce the processing expense and/or to improve the accuracy of the measurement, the measured values  $m_i$  can be preprocessed before fitting, e.g. by removing outliers or by numerical smoothing. In that case, the actual fitting process does not use the raw values  $m_i$  and  $f_i$  but values derived therefrom.

[0085] After determining the parameters  $b_j$  in the fitting process, at least some of the input values  $s_i$  are derived from at least some of the parameters  $b_j$ . For example,  $s_1$  can be set to  $b_0$ ,  $s_2$  can be set to  $b_1$  etc., or  $b_0$  through  $b_k$  can be used to calculate the resonance frequency  $f_0$  and the value of function  $M$  at  $f_0$  and the two values obtained in this way can be used as input values  $s_1$  and  $s_2$ , respectively.

[0086] In a simple embodiment, a polynomial of third degree is used for function  $M$ , i.e.

$$M(f, b_0, \dots, b_k) = b_0 + b_1 \cdot f + b_2 \cdot f^2 + b_3 \cdot f^3 \quad (9)$$

is used. Polynomials of degree  $R$  with  $R > 3$  or  $R = 2$  can be used as well, but it has been found that polynomials of lower degree do not describe a possible asymmetry of the data sufficiently well, and the available data does not provide

sufficient information for determining more than four parameters.

**[0087]** As known to a person skilled in the art and as described in chapter "General Linear Least Squares" in the book of Press et al. mentioned above, fitting a function that is linear in its parameters  $b_i$ , such as the one of equation (9), to a data set can be carried out by solving the matrix equation

5

$$(\mathbf{A}^T \cdot \mathbf{A}) \cdot \mathbf{b} = \mathbf{A}^T \cdot \mathbf{m}, \quad (10)$$

10

where, for the function of equation (9), A is the matrix

15

$$A_{ij} = f_i^j, \quad (11)$$

$\mathbf{b}$  is the vector of the parameters  $\{b_0 \dots b_K\}$  and  $\mathbf{m}$  the vector of the values  $\{m_1 \dots m_L\}$ . In general, when function M takes the form

20

$$M(f, b_0, \dots, b_K) = \sum_{k=0}^K b_k \cdot \chi_k(f) \quad (12)$$

25

with  $\chi_k$  being arbitrary functions of frequency f, matrix  $A_{ij}$  is given by

30

$$A_{ij} = \chi_j(f_i) \quad (13)$$

35

**[0088]** (Equations (11) and (13) assume that the measurement errors of all measurements are equal. If not, the equations must be corrected as described in the textbook of Press et al., chapter 15.4. In the following, as well as in the claims, the simple form of equations (11) and (13) is used, but the application of error corrected formulae for  $A_{ij}$  is deemed to be an equivalent thereof.)

40

**[0089]** As can be seen, matrix  $\mathbf{A}$  does not depend on the measured values  $m_i$  but only on the frequencies  $f_i$ . If the same frequencies  $f_i$  are used in each sweep, matrix  $\mathbf{A}$  as well as  $(\mathbf{A}^T \cdot \mathbf{A})$  and its inverse can be precalculated and stored in advance, thereby obviating the need for calculating them for each frequency sweep and taking computational load from microprocessor 38, which allows to increase the number of sweeps and/or to decrease power consumption. Preferably,  $(\mathbf{A}^T \cdot \mathbf{A})^{-1} \cdot \mathbf{A}^T$  is precalculated and stored, but it is also possible to store any other suitable data describing the precalculated matrix  $\mathbf{A}$ .

45

**[0090]** Electrode design:

The geometry of the electrodes 5, 6 is selected such that the electric AC-field generated by them extends into the tissue to be measured. Advantageously, at least one of the electrodes of the capacitor is electrically insulated such that capacitor C attached to the body, which can be modeled as a resistive and capacitive load, results primarily a capacitive load, the capacitance and loss of which depend on the electrical properties (i.e. the response) of the specimen at the frequency of VCO 1.

50

The design of the electrodes 5, 6 of the present sensor can correspond to the one described in reference to Figs. 2 and 4 of WO 02/069791, which description is enclosed by reference herein.

55

**[0091]** In an advantageous embodiment, though, an electrode arrangement as shown in Fig. 7 is used. In this figure, the hatched area corresponds to the area covered by insulating layer 5a, while the dotted areas correspond to the areas covered by electrodes 5 and 6.

**[0092]** As can be seen, outer electrode 6 is of elongate shape having two lateral sections 6a, 6b extending substantially parallel to strip electrode 5, wherein section 6b is wider than section 6a. An inner edge 6c of outer electrode 6 encloses

a central area 50 of substantially rectangular shape. Strip electrode 5 is located substantially in the center of central area 50.

[0093] Insulating layer 5a covers substantially all of central area 50 as well as part of the wider lateral section 6b of outer electrode 6.

[0094] Any surface of an electrode that can come into contact with the specimen should be of gold or another noble metal for best biological compatibility. In the embodiment of Fig. 7, at least outer electrode 6 is advantageously covered by a gold layer.

[0095] For the same reason, at least those through-contacts 10 that are not covered by insulating layer 5a should be covered by glass, ceramics, plastics, a noble metal layer or any other biologically inert material. In the embodiment of Fig. 1, the through-contacts 10 are therefore covered by drops of glass 51.

[0096] Notes:

In the above description, the voltage over resonant circuit 35 was measured at input u1. It must be noted, though, that it would also be possible to measure another voltage or current that depends on the impedance of the electrode arrangement. In particular, it would be possible to measure the voltage drop over resistor R1 or inductance L instead of the voltage over resonant circuit 35.

[0097] In any case, the processing circuitry 37, 38 should measure a response of the electrode arrangement to the applied electric signal, i.e. the measured value should depend on the dielectric properties of the specimen at the electrode.

[0098] Furthermore, resonant circuit 35 might also be implemented as a capacitor parallel to an inductance instead of having the capacitor arranged in series to the inductance.

[0099] Finally, it must be noted that the electrode arrangement shown in Figs. 1 and 7 is only one of various possible embodiments. For example, outer electrode 6 might be replaced by a part of the (metallic) housing 1 of device 100 extending to the electrode face of the device. In that case, metallic housing 1 would form part of the electrode arrangement.

[0100] While there are shown and described presently preferred embodiments of the invention, it is to be distinctly understood that the invention is not limited thereto but may be otherwise variously embodied and practiced within the scope of the following claims.

## Claims

1. A device for measuring a property of living tissue, in particular a glucose level of the tissue, said device comprising an electrode arrangement (5, 6) for application to the tissue, a signal source (31) for generating an AC voltage ( $V_{VCO}$ ) in a given frequency range to be applied to said electrode arrangement (5, 6), and processing circuitry (37, 38) for measuring a response of the electrode arrangement (5, 6), said response depending on dielectric properties of the tissue, and for converting said response to said property, wherein said electrode arrangement comprises at least one electrode (5, 6) placed on an outer side of an electrically insulating substrate (4), at least one through-contact (10, 11) extending through said substrate (4) and connecting said at least one electrode (5, 6), **characterized in that** an outer side of each through-contact is covered by a physiologically inert material.
2. The device of claim 1 further comprising a voltage-controlled oscillator (31) for generating an AC voltage ( $V_{VCO}$ ) in a given frequency range to be applied to said electrode arrangement (5, 6), wherein the voltage-controlled oscillator (31) comprises at least one amplifier (T1, T2) having an input for a gain control signal (V2) affecting a gain of the amplifier, at least one tank circuit (L1, D1; L2, D2) comprising at least one voltage-controlled capacitor (D1, D2) having an input for a frequency control signal (V1), said frequency control signal (V1) determining a frequency of operation of the voltage-controlled oscillator (31), said device further being adapted to control said gain control signal (V2) for increasing the gain when the DC-voltage over said at least one voltage-controlled capacitor (D1, D2) is close to zero.
3. The device of claim 2 wherein said at least one voltage-controlled capacitor (D1, D2) is a varactor diode.
4. The device of any of the preceding claims wherein said at least one amplifier (T1, T2) is at least one dual gate FET having two gates, wherein one of the gates of the dual gate FET is connected to the gain control signal (V2).

- 5
- 6
- 10
- 15
- 20
- 25
- 30
- 35
- 40
- 45
- 50
- 55
5. The device of any of the preceding claims wherein said voltage-controlled oscillator (31) comprises two amplifiers (T1, T2), each amplifier having an amplifier output, and two tank circuits (L1, D1; L2, D2) operating at a phase shift of 180°, wherein an output voltage of said voltage-controlled oscillator (31) is derived from a voltage drop over said amplifier outputs.
  6. The device of claim 5 further comprising a transformer, wherein one winding of said transformer is arranged between said amplifier outputs.
  7. The device of any of the claims 2 to 6 further comprising at least one filter (C3 - C6) for suppressing AC components in the frequency control voltage and/or the gain control voltage.
  8. The device of any of the claims 2 to 7 comprising a feedback loop for controlling said control signal (V2) to keep an output voltage of said voltage controlled oscillator (31) within a desired range of values.
  9. The device of claim 8 wherein said device is adapted to carry out consecutive measurement cycles i and wherein said feedback loop is adapted to, in at least some of the measurement cycles i, carry out a comparison of the output voltage of the voltage controlled oscillator (31) with an optimum value ( $u_{2_{opt}}$ ) and to correct the control signal (V2) of a next measurement cycle i+1 depending on the result of the comparison.
  10. The device of any of the preceding claims wherein said signal source (31) is adapted for generating an AC voltage ( $V_{VCO}$ ) of a selectable frequency (f) in the given frequency range to be applied to said electrode arrangement (5, 6), wherein the processing circuitry (37, 38) comprises
    - at least one diode (D10, D11, D20, D21) for rectifying an input voltage from an input (u1, u2) and generating a rectified signal,
    - a filter (C10, C11, C20, C21) for smoothing the rectified signal,
    - an AD converter (A/D) for converting the rectified signal or a signal derived from the rectified signal to a digital value (o1, o2), wherein said digital value (o1, o2) is dependent on but not proportional to an AC amplitude (x) of the input voltage,
    - a processor (38) for converting the digital value (o1, o2) to a signal value substantially proportional to the AC amplitude (x) of the input voltage.
  11. The device of claim 10 wherein said processor (38) is adapted to convert said digital value (o1, o2) to said signal value using calibration data.
  12. The device of any of the claims 10 or 11 wherein said calibration data describes the conversion of the digital value (o1, o2) to the signal value at a plurality of different frequencies (f), wherein said processor (38) is adapted to use calibration data attributed to a current frequency of the signal source.
  13. The device of any of the claims 10 to 12 wherein said calibration data describes the conversion of the digital value (o1, o2) to the signal value at a plurality of different temperatures (T), wherein said processor (38) is adapted to use calibration data attributed to a current temperature.
  14. The device of any of the claims 10 to 13 comprising
    - a first diode (D10, D20) and a first filter C10, R10; C20, R20) for generating a first voltage depending on a minimum value of the input voltage and a second diode (D11, D21) and a second filter (C11, R11, C21, R21) for generating a second voltage depending on a maximum value of the input voltage, and
    - means (A11, A21) for determining a difference between said first and said second voltage.
  15. The device of claim 14 wherein said first diode is in series to said first filter and said first filter is connected to a first fixed voltage, and wherein said second diode is in series to said second filter and said second filter is connected to a second fixed voltage, said first fixed voltage being higher than said second fixed voltage.
  16. The device of any of the claims 10 to 15 wherein said processing circuitry (37) comprises two inputs (u1, u2), a first input (u1) being connected to said electrode arrangement (5, 6) and a second input (u2) being connected to said AC voltage ( $V_{AC}$ ).
  17. The device of any of the preceding claims wherein said processing circuitry (37, 38) comprises measuring means for measuring a series of measurement values ( $m_i$ ) at the series of frequencies ( $f_i$ ), each meas-

urement value ( $m_i$ ) depending on dielectric properties of the tissue at one frequency,  
 fitting means for fitting a function  $M(f, b_0, \dots, b_K)$  with parameters  $b_0$  to  $b_K$  to the measurement values ( $m_i$ ) at their  
 given frequencies ( $f_i$ ), or to values derived from the measurement values ( $m_i$ ) at their given frequencies ( $f_i$ ), and  
 determining the parameters  $b_0$  to  $b_K$  thereby, and  
 means for using at least part of the parameters  $b_0$  to  $b_K$  for determining said property.

18. The device of claim 17 wherein said processing circuitry (37, 38) comprises a measuring circuit (37) having a first  
 input (u1) for an input value dependent on said property and on said AC voltage and a second input (u2) for an input  
 value dependent on said AC voltage but substantially independent of said property, wherein said measurement  
 values ( $m_i$ ) are derived from a ratio between said first and said second input value.

19. The device of any one of the claims 17 or 18 wherein said function  $M(f, b_0, \dots, b_K)$  is of the form

$$M(f, b_0, \dots, b_K) = b_0 + b_1 \cdot f + \dots + b_3 \cdot f^R,$$

in particular with  $R = 3$ .

20. The device of any one of the claims 17 to 19, wherein said function  $M(f, b_0, \dots, b_K)$  is of the form

$$M(f, b_0, \dots, b_K) = \sum_{k=0}^K b_k \cdot \chi_k(f)$$

and wherein said fitting means is adapted to store a precalculated matrix  $\mathbf{A}$  and/or data derived from said precalculated  
 matrix  $\mathbf{A}$  for fitting a plurality of series of measurement values, wherein matrix  $\mathbf{A} = A_{ij}$  is defined by

$$A_{ij} = \chi_j(f_i),$$

21. The device of claim 20 wherein said fitting means is adapted to store the matrix  $(\mathbf{A}^T \cdot \mathbf{A})^{-1} \cdot \mathbf{A}^T$ .

22. The device of any of the preceding claims wherein said electrode arrangement comprises  
 a strip electrode (5) for being placed against said body,  
 an outer electrode (6) for being placed against said body, wherein said outer electrode comprises two lateral sections  
 (6a, 6b) extending substantially parallel to and on opposite sides of said strip electrode (5), wherein a first (6b) of  
 said sections is wider than a second (6a) of said sections.

23. The device of claim 22 further comprising an insulating layer (5a) covering said strip electrode (5) and at least part  
 of said first section (6b) of said outer electrode (6).

24. The device of any of the claims 22 or 23 wherein said outer electrode (6) is annular.

25. The device of any of the preceding claims wherein the outer side of each through-contact is covered by a material  
 selected from the group of glass, ceramics, plastics and a noble metals.

26. The device of any of the preceding claims, wherein said electrode arrangement comprises at least a first electrode  
 for being brought into direct contact with said body and wherein a surface of said first electrode consists of noble metal.

27. The device of claim 26 wherein the surface of said first electrode consists of gold.

28. The device of any of the preceding claims wherein said electrode arrangement is part of a resonant circuit, and in  
 particular wherein a resonance frequency of the resonant circuit lies in the given frequency range.

29. The device of claim 28 wherein said electrode arrangement forms a capacitor (C) and is arranged in series to or parallel to an inductance (L), wherein said capacitor (C) and said inductance (L) form said resonant circuit.
30. The device of any of the preceding claims wherein said electrode arrangement (5, 6) is arranged on a flat substrate (4).

5

### Patentansprüche

1. Vorrichtung zur Messung einer Eigenschaft von lebendem Gewebe, insbesondere eines Glukosespiegels des Gewebes, wobei die Vorrichtung eine Elektrodenanordnung (5, 6) zur Anwendung auf dem Gewebe, eine Signalquelle (31) zur Generierung einer Wechselfspannung ( $V_{VCO}$ ) in einem gegebenen Frequenzbereich zum Anlegen an die Elektrodenanordnung (5, 6), und Verarbeitungsschaltungen (37, 38) zur Messung einer Antwort der Elektrodenanordnung (5, 6), wobei die Antwort von dielektrischen Eigenschaften des Gewebes abhängt, und zur Konvertierung der Antwort in die Eigenschaft, umfasst, wobei die Elektrodenanordnung mindestens eine Elektrode (5, 6), welche auf einer Aussenseite eines elektrisch isolierenden Substrats (4) angeordnet ist, mindestens einen durchgehenden Kontakt (10, 11), welcher sich durch das Substrat (4) erstreckt und die mindestens eine Elektrode (5, 6) verbindet, umfasst, **dadurch gekennzeichnet, dass** eine Aussenseite eines jeden durchgehenden Kontakts von einem physiologisch inaktiven Material bedeckt ist.
2. Vorrichtung nach Anspruch 1, weiter umfassend einen spannungsgesteuerten Oszillator (31) zur Generierung einer Wechselfspannung ( $V_{VCO}$ ) in einem gegebenen Frequenzbereich, zum Anlegen an die Elektrodenanordnung (5, 6), wobei der spannungsgesteuerte Oszillator (31) mindestens einen Verstärker (T1, T2) mit einem Eingang für ein Verstärkungssteuersignal (V2), welches die Verstärkung des Verstärkers beeinflusst, mindestens einen Tank-Kreis (L1, D1; L2, D2) umfassend mindestens einen spannungsgesteuerten Kondensator (D1, D2) mit einem Eingang für ein Frequenzsteuersignal (V1), wobei das Frequenzsteuersignal (V1) eine Betriebsfrequenz des spannungsgesteuerten Oszillator (31) bestimmt, umfasst, wobei die Vorrichtung weiter zur Steuerung des Verstärkungssteuersignals (V2) zur Erhöhung der Verstärkung, wenn die Gleichspannung am mindestens einen spannungsgesteuerten Kondensator (D1, D2) nahe Null ist, angepasst ist.
3. Vorrichtung nach Anspruch 2, wobei der mindestens eine spannungsgesteuerte Kondensator (D1, D2) eine Reaktanzdiode ist.
4. Vorrichtung nach einem der vorangehenden Ansprüche, wobei der mindestens eine Verstärker (T1, T2) mindestens ein Dual-Gate FET mit zwei Toren ist, wobei eines der Tore des Dual-Gate FETs am Verstärkungssteuersignal (V2) angeschlossen ist.
5. Vorrichtung nach einem der vorangehenden Ansprüche, wobei der spannungsgesteuerte Oszillator (31) zwei Verstärker (T1, T2) umfasst, wobei jeder Verstärker einen Verstärkerausgang und zwei Tank-Schaltungen (L1, D1; L2, D2) hat, welche bei einer Phasenverschiebung von  $180^\circ$  arbeiten, wobei eine Ausgangsspannung des spannungsgesteuerten Oszillators (31) von einem Spannungsabfall über die Verstärkerausgänge abgeleitet ist.
6. Vorrichtung nach Anspruch 5, weiter umfassend einen Transformator, wobei eine Wicklung des Transformators zwischen den Verstärkerausgängen angeordnet ist.
7. Vorrichtung nach einem der Ansprüche 2 bis 6, weiter umfassend mindestens einen Filter (C3 - C6) zur Unterdrückung von Wechselkomponenten der Frequenzsteuerspannung und/oder der Verstärkungssteuerspannung.
8. Vorrichtung nach einem der Ansprüche 2 bis 7, umfassend eine Rückkopplungsschleife zur Steuerung des Steuerungssignals (V2) zur Beibehaltung einer Ausgangsspannung des spannungsgesteuerten Oszillators (31) innerhalb

eines gewünschten Wertebereichs.

- 5 9. Vorrichtung nach Anspruch 8, wobei die Vorrichtung zur Durchführung von wiederholten Messzyklen  $i$  angepasst ist, und wobei die Rückkopplungsschleife zur Durchführung eines Vergleichs, in mindestens einigen der Messzyklen  $i$ , der Ausgangsspannung des spannungsgesteuerten Oszillators (31) mit einem optimalen Wert ( $u_{2opt}$ ) und zur Korrektur des Kontrollsignals ( $V_2$ ) eines folgenden Messzykluses  $i+1$  in Abhängigkeit vom Ergebnis des Vergleichs angepasst ist.
- 10 10. Vorrichtung nach einem der vorangehenden Ansprüche, wobei die Signalquelle (31) zur Generierung einer Wechselspannung ( $V_{VCO}$ ) mit einer wählbaren Frequenz ( $f$ ) im gegebenen Frequenzbereich zum Anlegen an die Elektrodenanordnung (5, 6) angepasst ist, wobei die Verarbeitungsschaltungen (37, 38) mindestens eine Diode ( $D_{10}$ ,  $D_{11}$ ,  $D_{20}$ ,  $D_{21}$ ) zur Korrektur einer Eingangsspannung von einem Eingang ( $u_1$ ,  $u_2$ ) und zur Generierung eines korrigierten Signals, einen Filter ( $C_{10}$ ,  $C_{11}$ ,  $C_{20}$ ,  $C_{21}$ ) zur Glättung des korrigierten Signals, 15 einen AD Konverter (A/D) zur Konvertierung des korrigierten Signals oder eines vom korrigierten Signal abgeleiteten Signals in einen Digitalwert ( $o_1$ ,  $o_2$ ), wobei der Digitalwert ( $o_1$ ,  $o_2$ ) von einer AC-Amplitude ( $x$ ) der Eingangsspannung abhängig aber nicht proportional dazu ist, einen Prozessor (38) zur Konvertierung des Digitalwerts ( $o_1$ ,  $o_2$ ) in einen Signalwert, welcher im Wesentlichen proportional zur AC-Amplitude ( $x$ ) der Eingangsspannung ist, 20 umfasst.
11. Vorrichtung nach Anspruch 10, wobei der Prozessor (38) zur Konvertierung des Digitalwerts ( $o_1$ ,  $o_2$ ) in den Signalwert unter Verwendung von Kalibrationsdaten angepasst ist.
- 25 12. Vorrichtung nach einem der Ansprüche 10 oder 11, wobei die Kalibrationsdaten die Konvertierung des Digitalwerts ( $o_1$ ,  $o_2$ ) in den Signalwert bei einer Vielzahl von Frequenzen ( $f$ ) beschreibt, wobei der Prozessor (38) zur Verwendung von Kalibrationsdaten, welche einer aktuellen Frequenz der Signalquelle zugeordnet sind, angepasst ist.
- 30 13. Vorrichtung nach einem der Ansprüche 10 bis 12, wobei die Kalibrationsdaten die Konvertierung des Digitalwerts ( $o_1$ ,  $o_2$ ) in den Signalwert bei einer Vielzahl von verschiedenen Temperaturen ( $T$ ) beschreibt, wobei der Prozessor (38) zur Verwendung von Kalibrationsdaten, welche einer aktuellen Temperatur zugeordnet sind, angepasst ist.
- 35 14. Vorrichtung nach einem der Ansprüche 10 bis 13, umfassend eine erste Diode ( $D_{10}$ ,  $D_{20}$ ) und einen ersten Filter ( $C_{10}$ ,  $R_{10}$ ;  $C_{20}$ ,  $R_{20}$ ) zur Generierung einer ersten Spannung in Abhängigkeit von einem Minimalwert der Eingangsspannung und eine zweite Diode ( $D_{11}$ ,  $D_{21}$ ) und einen zweiten Filter ( $C_{11}$ ,  $R_{11}$ ;  $C_{21}$ ,  $R_{21}$ ) zur Generierung einer zweiten Spannung in Abhängigkeit von einem Maximalwert der Eingangsspannung, und Mittel ( $A_{11}$ ,  $A_{21}$ ) zur Bestimmung eines Unterschieds zwischen der ersten und der zweiten Spannung.
- 40 15. Vorrichtung nach Anspruch 14, wobei die erste Diode in Serie mit dem ersten Filter ist und der erste Filter an einer ersten festen Spannung angeschlossen ist, und wobei die zweite Diode in Serie mit dem zweiten Filter ist und der zweite Filter an einer zweiten Spannung angeschlossen ist, wobei die erste feste Spannung höher als die zweite feste Spannung ist.
- 45 16. Vorrichtung nach einem der Ansprüche 10 bis 15, wobei die Verarbeitungsschaltungen (37) zwei Eingänge ( $u_1$ ,  $u_2$ ) umfassen, wobei ein erster Eingang ( $u_1$ ) an der Elektrodenanordnung (5, 6) angeschlossen ist und ein zweiter Eingang ( $u_2$ ) an der Wechselspannung ( $V_{AC}$ ) angeschlossen ist.
- 50 17. Vorrichtung nach einem der vorangehenden Ansprüche, wobei die Verarbeitungsschaltungen (37, 38) Messmittel zur Messung einer Reihe von Messwerten ( $m_i$ ) bei der Reihe von Frequenzen ( $f_i$ ), wobei jeder Messwert ( $m_i$ ) von dielektrischen Eigenschaften des Gewebes bei einer Frequenz abhängt, Anpassungsmittel zur Anpassung einer Funktion  $M(f, b_0, \dots, b_k)$  mit Parametern  $b_0$  bis  $b_k$  an die Messwerte ( $m_i$ ) bei ihren gegebenen Frequenzen ( $f_i$ ), oder an Werten, welche von den Messwerten ( $m_i$ ) bei ihren gegebenen Frequenzen ( $f_i$ ) abgeleitet sind, und zur Bestimmung der Parameter  $b_0$  bis  $b_k$  daraus, und 55 Mittel zur Verwendung von mindestens einem Teil der Parameter  $b_0$  bis  $b_k$  zur Bestimmung der Eigenschaft, umfassen.
18. Vorrichtung nach Anspruch 17, wobei die Verarbeitungsschaltungen (37, 38) eine Messschaltung (37) umfassen,

## EP 1 694 197 B1

welche einen ersten Eingang ( $u_1$ ) für einen von der Eigenschaft und der Wechselspannung abhängigen Eingangswert und einen zweiten Eingang ( $u_2$ ) für einen von der Wechselspannung abhängigen aber im Wesentlichen von der Eigenschaft unabhängigen Eingangswert hat, wobei die Messwerte ( $m_i$ ) von einem Verhältnis zwischen dem ersten und dem zweiten Eingangswert abgeleitet sind.

5

19. Vorrichtung nach einem der Ansprüche 17 oder 18, wobei die Funktion  $M(f, b_0, \dots, b_k)$  die Form

$$M(f, b_0, \dots, b_k) = b_0 + b_1 \cdot f + \dots + b_k \cdot f^R,$$

10

hat, insbesondere mit  $R = 3$ .

15

20. Vorrichtung nach einem der Ansprüche 17 bis 19, wobei die Funktion  $M(f, b_0, \dots, b_k)$  die Form

$$M(f, b_0, \dots, b_k) = \sum_{k=0}^K b_k \cdot X_k(f)$$

20

hat, und wobei das Anpassungsmittel zur Speicherung einer vorberechneten Matrix  $\mathbf{A}$  und/oder von Daten, welche von der vorberechneten Matrix  $\mathbf{A}$  abgeleitet sind, angepasst ist, zur Anpassung einer Vielzahl von Messwertreihen, wobei die Matrix  $\mathbf{A} = A_{ij}$  durch

25

$$A_{ij} = X_j(f_i)$$

30

definiert ist.

21. Vorrichtung nach Anspruch 20, wobei das Anpassungsmittel zur Speicherung der Matrix  $(\mathbf{A}^T \cdot \mathbf{A})^{-1} \cdot \mathbf{A}^T$  angepasst ist.

35

22. Vorrichtung nach einem der vorangehenden Ansprüche, wobei die Elektrodenanordnung eine Streifenelektrode (5) zur Positionierung am Körper, eine äussere Elektrode (6) zur Positionierung am Körper, umfasst,

40

wobei die äussere Elektrode zwei seitliche Abschnitte (6a, 6b) umfasst, welche sich im Wesentlichen parallel zum und auf gegenüberliegenden Seiten der Streifenelektrode (5) erstrecken, wobei ein erster (6b) der Abschnitte breiter als ein zweiter (6a) der Abschnitte ist.

23. Vorrichtung nach Anspruch 22, weiter umfassend eine Isolationsschicht (5a), welche die Streifenelektrode (5) und mindestens einen Teil der ersten Elektrode (6b) der äusseren Elektrode (6) bedeckt.

45

24. Vorrichtung nach einem der Ansprüche 22 oder 23, wobei die äussere Elektrode (6) ringförmig ist.

25. Vorrichtung nach einem der vorangehenden Ansprüche, wobei die Aussenseite des jeden durchgängigen Kontakts von einem Material bedeckt ist, welches aus einer Gruppe von Glass, Keramiken, Kunststoffen und Edelmetallen ausgewählt ist.

50

26. Vorrichtung nach einem der vorangehenden Ansprüche, wobei die Elektrodenanordnung mindestens eine erste Elektrode zum Bringen in direktem Kontakt mit dem Körper umfasst und wobei eine Oberfläche der ersten Elektrode aus Edelmetall besteht.

55

27. Vorrichtung nach Anspruch 26, wobei die Oberfläche der ersten Elektrode aus Gold besteht.

28. Vorrichtung nach einem der vorangehenden Ansprüche, wobei die Elektrodenanordnung ein Teil einer Resonanz-

schaltung ist, und insbesondere wobei eine Resonanzfrequenz der Resonanzschaltung im gegebenen Frequenzbereich liegt.

29. Vorrichtung nach Anspruch 28, wobei die Elektrodenanordnung einen Kondensator (C) bildet und in Serie oder parallel zu einer Induktivität (L) angeordnet ist, wobei der Kondensator (C) und die Induktivität (L) die Resonanzschaltung bilden.

30. Vorrichtung nach einem der vorangehenden Ansprüche, wobei die Elektrodenanordnung (5, 6) auf einem flachen Substrat (4) angeordnet ist.

## Revendications

1. Dispositif pour la mesure d'une propriété de tissu vivant, particulièrement d'un niveau de glucose du tissu, le dispositif comprenant une assemblée d'électrodes (5, 6) pour l'application sur le tissu, une source de signal (31) pour la génération d'une tension alternative ( $V_{VCO}$ ) dans un intervalle donné de fréquences pour l'application à ladite assemblée d'électrodes (5, 6), et des circuits de traitement (37, 38) pour mesurer une réponse de l'assemblée d'électrodes (5, 6), ladite réponse dépendant de propriétés diélectriques du tissu, et pour convertir ladite réponse dans ladite propriété, ladite assemblée d'électrodes comprenant au moins une électrode (5, 6) étant arrangé d'un côté extérieur d'un substrat isolant électriquement (4), au moins un contact traversant (10, 11), qui s'étend à travers dudit substrat (4) et qui connecte au moins une électrode (5, 6), **caractérisé en ce qu'un côté extérieur de chacun des contacts traversant est couverte par un matériau physiologiquement inactif.**

2. Dispositif selon la revendication 1, comprenant en outre un oscillateur commandé en tension (31) pour générer une tension alternative ( $V_{VCO}$ ) dans un intervalle donné de fréquences, pour l'application à ladite assemblée d'électrodes (5, 6), l'oscillateur commandé en tension (31) comprenant au moins un amplificateur (T1, T2) avec une entrée pour un signal de commande de gain (V2) qui influence un gain de l'amplificateur, au moins un circuit oscillant (L1, D1; L2, D2) comprenant au moins une capacité commandée en tension (D1, D2) avec une entrée pour un signal de commande de fréquence (V1), ledit signal de commande de fréquence (V1) déterminant une fréquence d'opération de l'oscillateur commandé en tension (31), ledit dispositif étant en outre adapté pour commander ledit signal de commande de gain (V2) pour augmenter le gain quand la tension continue sur au moins l'une capacité commandée en tension est presque zéro.

3. Dispositif selon la revendication 2, l'au moins une capacité commandée en tension (D1, D2) étant une diode varactor.

4. Dispositif selon l'une des revendications précédentes, l'au moins un amplificateur (T1, T2) étant au moins un FET dual-gate ayant deux portes, une des portes du FET dual-gate étant connectée au signal de commande de gain (V2).

5. Dispositif selon l'une des revendications précédentes, l'oscillateur commandé en tension (31) comprenant deux amplificateurs (T1, T2), chaque amplificateur ayant une sortie d'amplificateur et deux circuits oscillants (L1, D1; L2, D2) opérant à un décalage de phase de  $180^\circ$ , une tension de sortie de l'oscillateur commandé en tension (31) étant dérivée d'une chute de tension sur lesdites sorties d'amplificateur.

6. Dispositif selon la revendication 5, comprenant en outre un transformateur, un enroulement dudit transformateur étant arrangé entre lesdites sorties de l'amplificateur.

7. Dispositif selon l'une des revendications 2 à 6, comprenant en outre au moins un filtre (C3 - C6) pour supprimer des composantes alternatives dans la tension de commande de fréquence et/ou la tension de commande de gain.

8. Dispositif selon l'une des revendications 2 à 7, comprenant une boucle de rétroaction pour commander ledit signal de commande (V2) pour maintenir une tension de sortie dudit oscillateur commandé en tension (31) dans un intervalle de valeurs demandé.

## EP 1 694 197 B1

- 5
9. Dispositif selon la revendication 8, ledit dispositif étant adapté à effectuer des cycles de mesures consécutives  $i$  et ladite boucle de rétroaction étant adaptée à effectuer, dans au moins quelques-uns des cycles de mesure  $i$ , une comparaison de la tension de sortie de l'oscillateur commandé en tension (31) avec une valeur optimale ( $u_{2opt}$ ) et à corriger le signal de commande ( $V_2$ ) d'un cycle de mesure suivant  $i+1$  dépendant du résultat de la comparaison.
- 10
10. Dispositif selon l'une des revendications précédentes, la source de signal (31) étant adaptée pour générer une tension alternative ( $V_{VCO}$ ) d'une sélectionnable fréquence ( $f$ ) dans l'intervalle donné de fréquences à être appliquée à ladite assemblée d'électrodes (5, 6), les circuits de traitement (37, 38) comprenant au moins une diode (D10, D11, D20, D21) pour rectifier une tension d'entrée d'une entrée ( $u_1, u_2$ ) et pour générer un signal rectifié, un filtre (C10, C11, C20, C21) pour lisser le signal rectifié, un convertisseur AD (A/D) pour convertir le signal rectifié ou un signal dérivé du signal rectifié dans une valeur numérique ( $o_1, o_2$ ), ladite valeur numérique ( $o_1, o_2$ ) étant dépendante mais pas proportionnelle à une amplitude AC ( $x$ ) de la tension d'entrée, un processeur (38) pour convertir la valeur numérique ( $o_1, o_2$ ) dans une valeur de signal essentiellement proportionnelle à l'amplitude AC ( $x$ ) de la tension d'entrée.
- 15
11. Dispositif selon la revendication 10, ledit processeur (38) étant adapté pour convertir ladite valeur numérique ( $o_1, o_2$ ) dans ladite valeur de signal en utilisant des données de calibration.
- 20
12. Dispositif selon l'une des revendications 10 ou 11, lesdites données de calibration décrivant la conversion de la valeur numérique ( $o_1, o_2$ ) dans la valeur de signal à des plusieurs fréquences ( $f$ ) différentes, ledit processeur (38) étant adapté pour utiliser des données de calibration attribuées à une fréquence courante de la source de signal.
- 25
13. Dispositif selon l'une des revendications 10 à 12, lesdites données de calibration décrivant la conversion de la valeur numérique ( $o_1, o_2$ ) dans la valeur de signal à des plusieurs températures ( $T$ ) différentes, ledit processeur (38) étant adapté pour utiliser des données de calibration attribuées à une température courante.
- 30
14. Dispositif selon l'une des revendications 10 à 13, comprenant une première diode (D10, D20) et un premier filtre (C10, R10; C20, R20) pour générer une première tension dépendant d'une valeur minimale de la tension d'entrée et une deuxième diode (D11, D21) et un deuxième filtre (C11, R11; C21, R21) pour générer une deuxième tension dépendant d'une valeur maximale de la tension d'entrée, et des moyens (A11, A21) pour déterminer une différence entre ladite première et ladite deuxième tension.
- 35
15. Dispositif selon la revendication 14, ladite première diode étant en série avec ledit premier filtre et ledit premier filtre étant connecté à une première tension fixe, et ladite deuxième diode étant en série avec ledit deuxième filtre et ledit deuxième filtre étant connecté à une deuxième tension fixe, ladite première tension fixe étant plus haute que ladite deuxième tension fixe.
- 40
16. Dispositif selon l'une des revendications 10 à 15, lesdits circuits de traitement (37) comprenant deux entrées ( $u_1, u_2$ ), une première entrée ( $u_1$ ) étant connectée à ladite assemblée d'électrodes (5, 6) et une deuxième entrée ( $u_2$ ) étant connectée à ladite tension alternative ( $V_{AC}$ ).
- 45
17. Dispositif selon l'une des revendications précédentes, lesdits circuits de traitement (37, 38) comprenant des moyens de mesure pour mesurer une série de valeurs de mesure ( $m_i$ ) à la série de fréquences ( $f_i$ ), chaque valeur de mesure ( $m_i$ ) dépendant d'une propriété diélectrique du tissu à une fréquence, des moyens d'ajustage pour ajuster une fonction  $M(f, b_0, \dots, b_k)$  avec des paramètres  $b_0$  à  $b_k$  aux valeurs de mesure ( $m_i$ ) à leurs fréquences données ( $f_i$ ), ou à des valeurs dérivées des valeurs de mesure ( $m_i$ ) à leurs fréquences données ( $f_i$ ), et déterminer par cela les paramètres  $b_0$  à  $b_k$ , et des moyens pour utiliser au moins une partie des paramètres  $b_0$  à  $b_k$  pour déterminer ladite propriété.
- 50
18. Dispositif selon la revendication 17, lesdits circuits de traitement (37, 38) comprenant un circuit de mesure (37) avec une première entrée ( $u_1$ ) pour une valeur d'entrée dépendante de ladite propriété et de ladite tension alternative et une deuxième entrée ( $u_2$ ) pour une valeur d'entrée dépendante de ladite tension alternative mais essentiellement indépendante de ladite propriété, lesdites valeurs de mesure ( $m_i$ ) étant dérivées d'un rapport entre ladite première et ladite deuxième valeur d'entrée.
- 55
19. Dispositif selon l'une des revendications 17 ou 18, ladite fonction  $M(f, b_0, \dots, b_k)$  ayant la forme

$$M(f, b_0, \dots, b_k) = b_0 + b_1 \cdot f + \dots + b_k \cdot f^k,$$

5

particulièrement avec  $R = 3$ .

20. Dispositif selon l'une des revendications 17 à 19, ladite fonction  $M(f, b_0, \dots, b_k)$  ayant la forme

10

$$M(f, b_0, \dots, b_k) = \sum_{k=0}^k b_k \cdot X_k(f)$$

15

et ledit moyen d'ajustage étant adapté pour la sauvegarde d'une matrice  $\mathbf{A}$  et/ou des données dérivées de ladite matrice  $\mathbf{A}$  pour ajuster une pluralité des séries de valeurs de mesure, la matrice  $\mathbf{A} = A_{ij}$  étant définie par

20

$$A_{ij} = X_j(f_i).$$

21. Dispositif selon la revendication 20, ledit moyen d'ajustage étant adapté pour sauvegarder la matrice  $(\mathbf{A}^T \cdot \mathbf{A})^{-1} \cdot \mathbf{A}^T$ .

25

22. Dispositif selon l'une des revendications précédentes, l'assemblée d'électrodes comprenant une électrode du type ruban (5) pour être arrangée audit corps, une électrode extérieure (6) pour être arrangée audit corps, ladite électrode extérieure comprenant deux section latérales (6a, 6b) s'étendant essentiellement parallèle et sur des côtés opposés par rapport à ladite électrode du type ruban (5), une première (6b) desdites sections étant plus large qu'une deuxième desdites sections.

30

23. Dispositif selon la revendication 22, comprenant en outre une couche d'isolation (5a) couvrant ladite électrode du type ruban (5) et au moins une partie de ladite section (6b) de ladite électrode extérieure (6).

35

24. Dispositif selon l'une des revendications 22 ou 23, ladite électrode extérieure (6) étant annulaire.

25. Dispositif selon l'une des revendications précédentes, la face extérieure de chaque contact traversant étant couverte par un matériau sélectionné d'un groupe de verre, céramiques, plastiques et métaux précieux.

40

26. Dispositif selon l'une des revendications précédentes, ladite assemblée d'électrodes comprenant au moins une première électrode pour être mise en contact direct avec ledit corps et une surface de ladite première électrode consistant de métal précieux.

27. Dispositif selon la revendication 26, la surface de ladite première électrode consistant d'or.

45

28. Dispositif selon l'une des revendications précédentes, ladite assemblée d'électrodes faisant partie d'un circuit résonant, et particulièrement une fréquence du circuit résonant étant comprise dans l'intervalle donné de fréquences.

29. Dispositif selon la revendication 28, l'assemblée d'électrodes formant une capacité (C) et étant arrangée en série ou en parallèle avec une bobine (L), ladite capacité (C) et ladite bobine (L) formant ledit circuit résonant.

50

30. Dispositif selon l'une des revendications précédentes, ladite assemblée d'électrodes (5, 6) étant arrangée sur un substrat (4) plat.

55

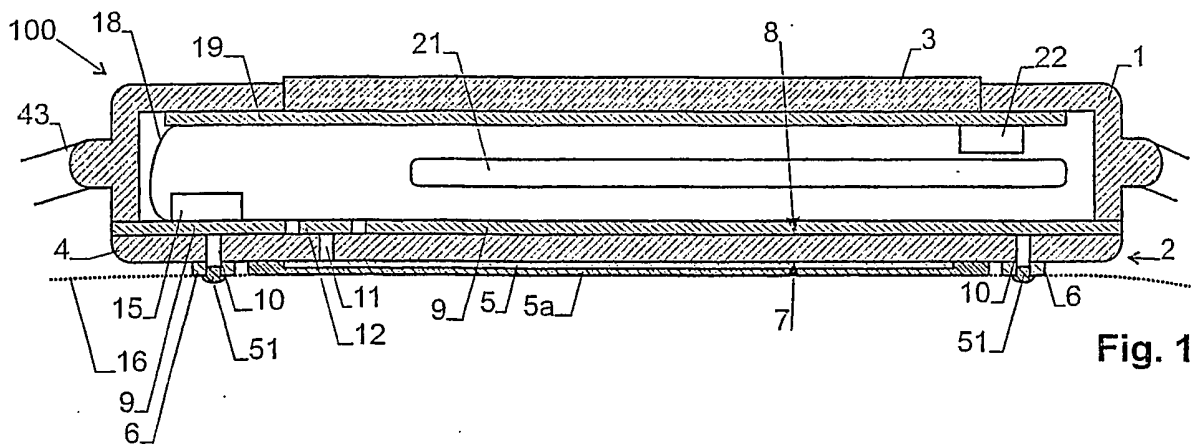

Fig. 1

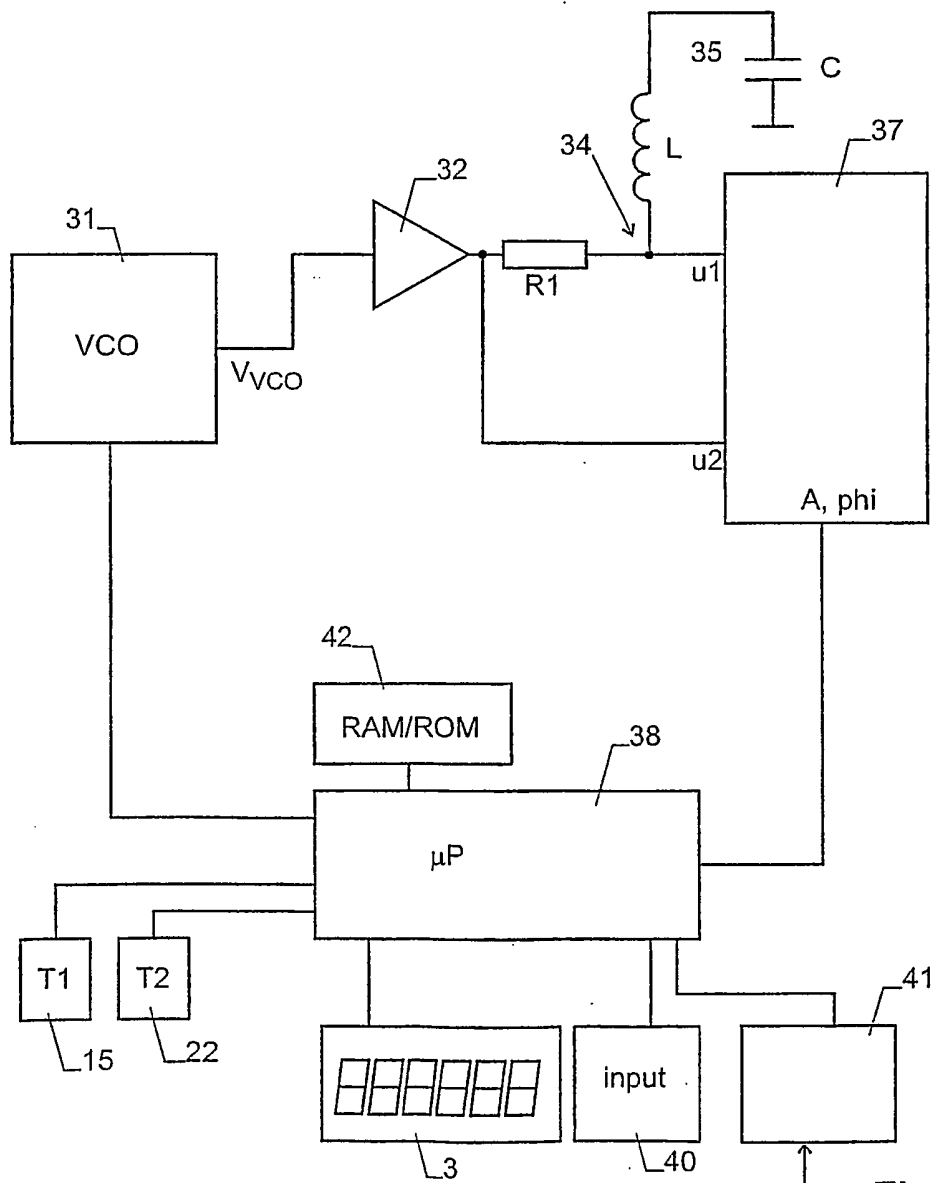

Fig. 2

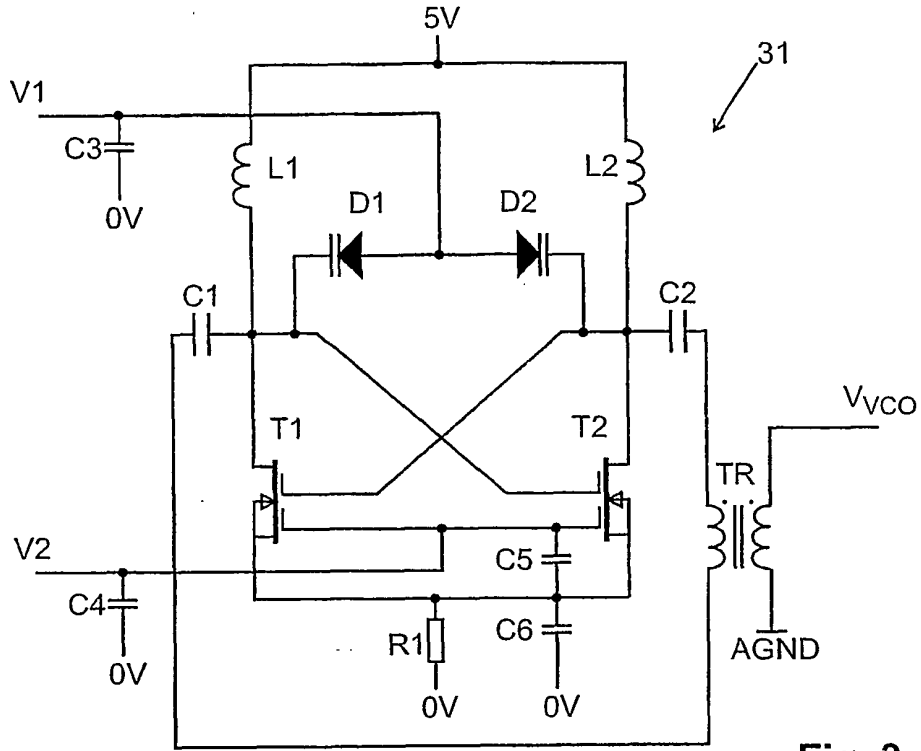

Fig. 3

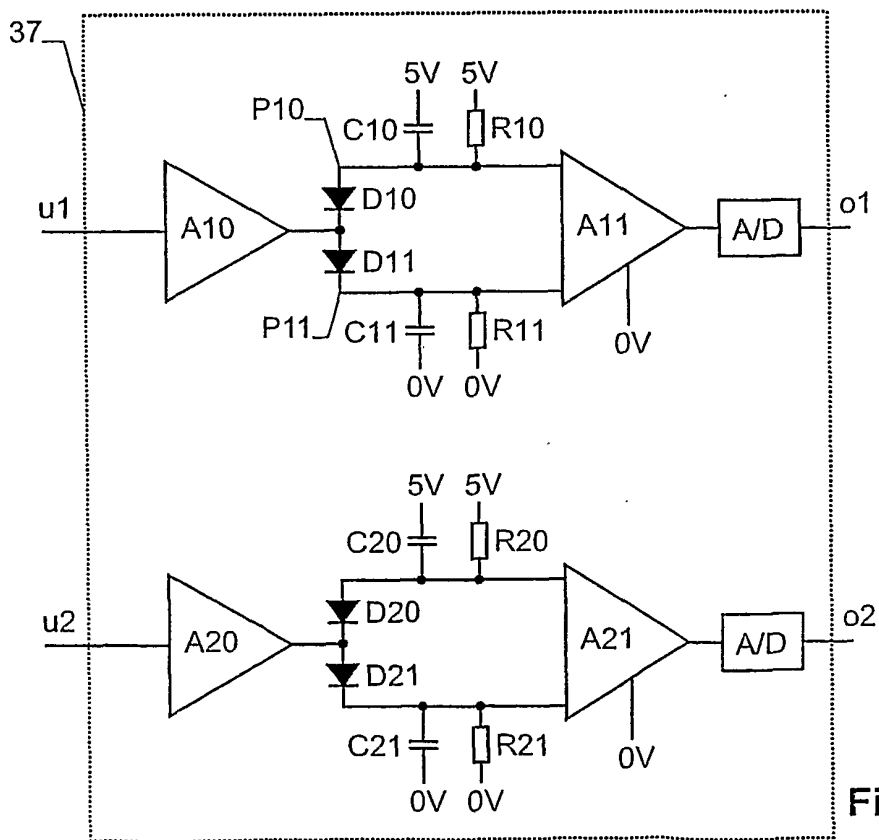

Fig. 4

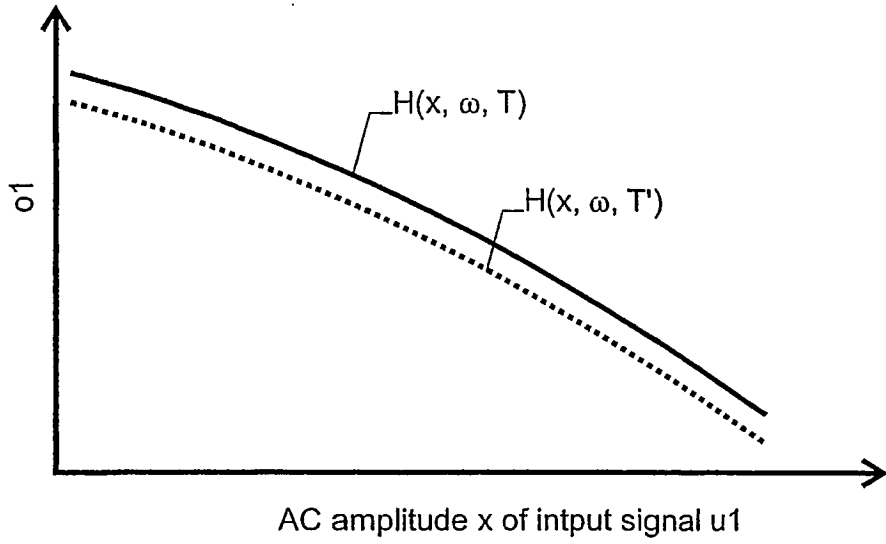

Fig. 5

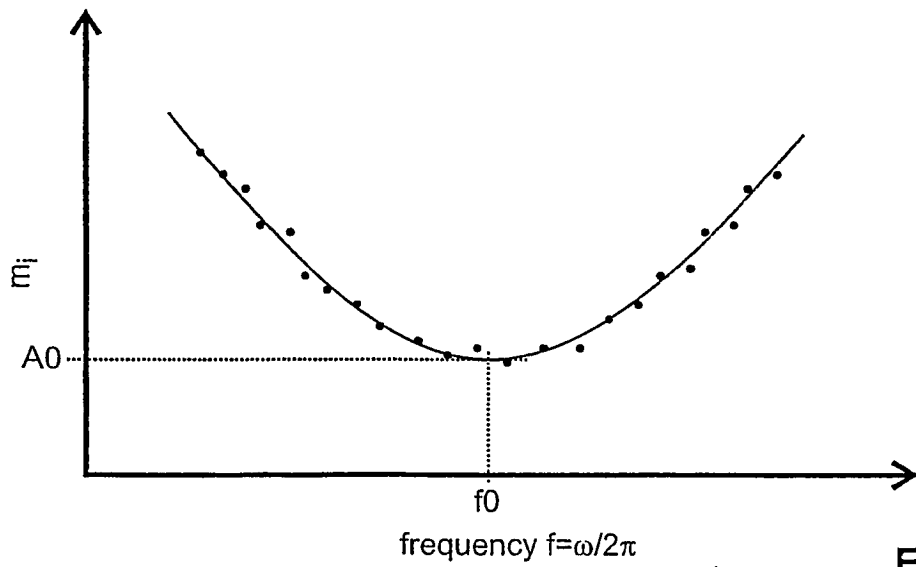

Fig. 6

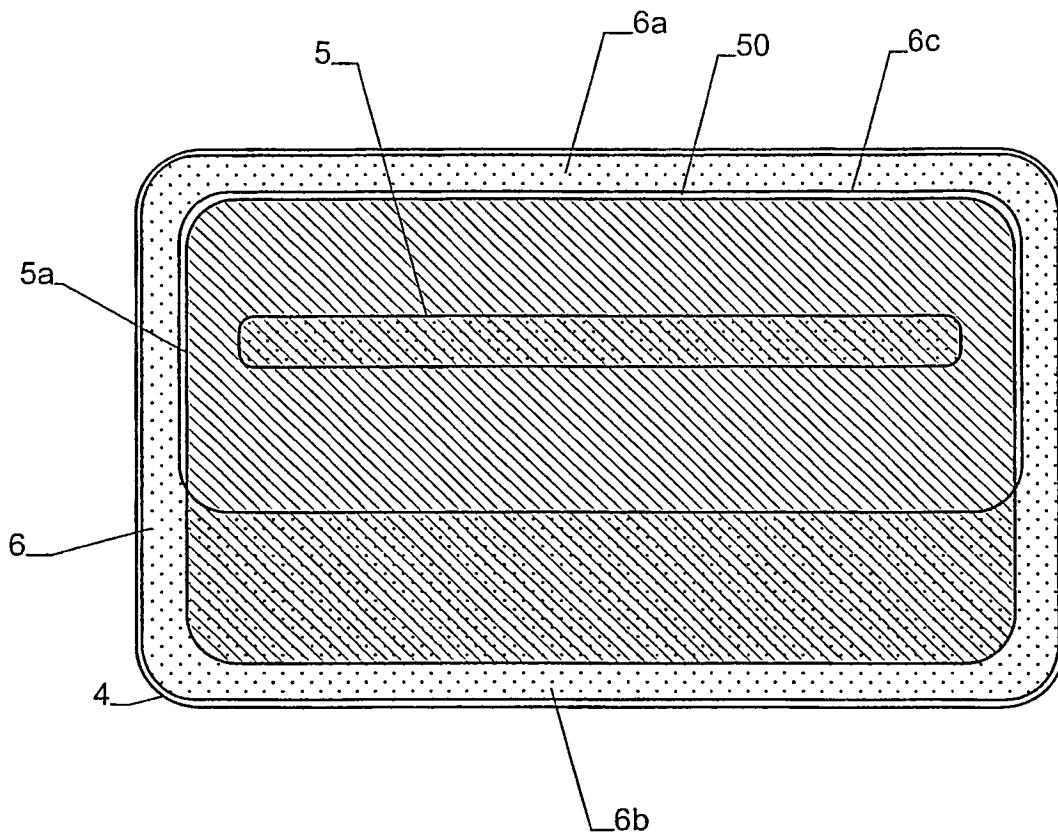

Fig. 7

**REFERENCES CITED IN THE DESCRIPTION**

*This list of references cited by the applicant is for the reader's convenience only. It does not form part of the European patent document. Even though great care has been taken in compiling the references, errors or omissions cannot be excluded and the EPO disclaims all liability in this regard.*

**Patent documents cited in the description**

- CH 0300795 W [0001]
- WO 02069791 A [0003] [0006] [0032] [0040] [0041]  
[0054] [0078] [0081] [0090]

专利名称(译)	一种用于测量活组织特性的装置和方法		
公开(公告)号	<a href="#">EP1694197B1</a>	公开(公告)日	2011-11-02
申请号	EP2004709566	申请日	2004-02-10
申请(专利权)人(译)	SOLIANIS HOLDING AG		
当前申请(专利权)人(译)	BIOVOTION AG		
[标]发明人	CADUFF ANDREAS BUSCHOR STEPHAN TRUFFER PASCAL HIRT ETIENNE STALDER GIANLUCA		
发明人	CADUFF, ANDREAS BUSCHOR, STEPHAN TRUFFER, PASCAL HIRT, ETIENNE STALDER, GIANLUCA		
IPC分类号	A61B5/00 A61B5/05		
CPC分类号	A61B5/411 A61B5/05 A61B5/14532		
优先权	PCT/CH2003/000795 2003-12-02 WO		
其他公开文献	EP1694197A1		
外部链接	<a href="#">Espacenet</a>		

摘要(译)

用于测量活组织中葡萄糖水平的装置具有用于与样本接触的电极 ( 5,6 ) 和作为用于在给定频率范围内产生AC电压的信号源的压控振荡器 ( 31 ) 。 AC电压施加到电极 ( 5,6 ) 。电极上的电压被馈送到处理电路 ( 37,38 ) ，处理电路使用校准数据将其转换为葡萄糖水平。压控振荡器 ( 31 ) 具有可调节增益的对称设计，用于在低电源电压下产生具有低失真的大频率范围内的信号。处理电路包括具有基于软件的校正的简单整流器网络。电极 ( 5,6 ) 具有不对称设计并且针对生物相容性进行了优化。

$$g = F(s_1, s_2, \dots, s_N, a_0, a_1, \dots, a_M) \quad (1)$$