



(11) **EP 1 487 335 B1**

(12) **EUROPEAN PATENT SPECIFICATION**

(45) Date of publication and mention of the grant of the patent:
20.10.2010 Bulletin 2010/42

(21) Application number: **02784285.5**

(22) Date of filing: **24.10.2002**

(51) Int Cl.:
A61B 5/103 (2006.01)

(86) International application number:
PCT/US2002/034245

(87) International publication number:
WO 2004/037083 (06.05.2004 Gazette 2004/19)

(54) **VAGINAL SENSING AND STIMULATING USING 2-WAY WIRELESS COMMUNICATIONS**

VAGINALE MESSUNG UND STIMULIERUNG MIT DRAHTLOSER ZWEIWEGE-KOMMUNIKATION

DETECTION ET STIMULATION VAGINALE A L'AIDE D'UN DISPOSITIF DE COMMUNICATION SANS FIL BIRECTIONNEL

(84) Designated Contracting States:
**AT BE BG CH CY CZ DE DK EE ES FI FR GB GR
IE IT LI LU MC NL PT SE SK TR**

(30) Priority: **26.10.2001 US 7393**

(43) Date of publication of application:
22.12.2004 Bulletin 2004/52

(73) Proprietor: **Athena Feminine Technologies, Inc.**
Orinda, CA 94563 (US)

(72) Inventors:
• **HOCHMAN, Joel, S.**
Houston, TX 77007 (US)

• **SARKIS, George**
Orinda, CA 94563 (US)

(74) Representative: **Radünz, Ingo**
Schumannstrasse 100
40237 Düsseldorf (DE)

(56) References cited:
WO-A-00/23030 WO-A-02/17987
US-A- 4 515 167 US-A- 5 233 987
US-A- 6 086 549 US-B1- 6 169 914
US-B1- 6 432 037

EP 1 487 335 B1

Note: Within nine months of the publication of the mention of the grant of the European patent in the European Patent Bulletin, any person may give notice to the European Patent Office of opposition to that patent, in accordance with the Implementing Regulations. Notice of opposition shall not be deemed to have been filed until the opposition fee has been paid. (Art. 99(1) European Patent Convention).

Description

Technical Field

[0001] The present invention relates to a system for transducing vaginal conditions, affecting vaginal or body conditions and/or stimulating perineal musculature and nerves. The present invention also relates to a method for accomplishing these functions.

Background Art

[0002] US Patent 4,515,167, Hochman, discloses a self-contained stimulation device that was programmable, prior to use, using control buttons on the surface of the device itself. Signals could also be emitted from the device to an external unit for processing. The drawbacks of this known device include the inability to alter its operation during use. In addition, this known device is not very ergonomic due in particular to the surface control buttons that are necessarily present on the device for its programming and operation.

[0003] Other vaginally insertable probes are also known, such as the fertility probes of US design patent D 393,311 and US patent 5,916,173, both to Kirsner. US patent 4,753,247, Kirsner, discloses a probe that is connected by wires to an external housing containing batteries and electronic circuitry.

[0004] WO 00/23030 to Gafni and Cohen discloses a probe for intravaginal sensing and stimulation, which may be completely insertable with internal power source. A hand-held control is in wireless contact with the probe to allow a patient to respond to stimulation.

[0005] Prior known devices fail to provide a system that can provide stimulation, deliver medication, and/or obtain physiological data intravaginally, via a wireless 2-way communication and in real time.

Disclosure of the Invention

[0006] It is therefore an object of the present invention to provide an ergonomic system and method that will allow, in a wireless manner and in real time, the transducing of vaginal conditions, the affecting of vaginal or body conditions, and the stimulation of perineal musculature and nerves in the human or other mammalian vagina, and in particular allows for real time remote control and/or programming of the intravaginally contained probe/transceiver unit.

[0007] The system of the present invention comprises: a separate, portable, non-implanted, intravaginally containable (i.e. in situ yet removable) combination probe and transceiver that is provided with means for sensing vaginal conditions, delivering signals or medication, and/or stimulating perineal musculature and nerves, wherein such probe unit is provided with 2-way wireless real time communication means for transmitting information that is transduced and for receiving control and pro-

gramming signals; and a separate combination controller and transceiver that is provided with wireless means for sending signals to the probe unit and for receiving signals therefrom, wherein a wireless signal feedback loop is provided between the controller and probe units and external devices, networks and databases.

[0008] The combination probe and transceiver is, in particular, a pre-programmed unit. The programming of this unit can, however, be altered. As indicated, 2-way communication is provided between the probe unit and the controller unit, which can be a hand-held unit, but could alternatively or in addition be a PC or other similar computer unit.

[0009] The probe of the inventive system contains no wires or similar external means or surface controls, and is therefore comfortable to use.

[0010] When the probe unit of the inventive system is used as a stimulation unit, women are provided a safe, easy and convenient way to strengthen and tone their pelvic muscles without professional intervention or special training.

[0011] In addition, or alternatively, the probe unit of the inventive system can be provided with solid state transducers or other sensor means that would be able to identify, for example, sexually transmitted pathogens, cancerous changes in the cervix and vaginal environment, metabolic abnormalities, physiological markers of the fertility cycle, and other physiological information. It may also be possible in this way to identify diseases by DNA sequences or by disease-specific molecular odors. The inventive system thus affords the ability of being able to provide the earliest possible diagnosis and treatment of pathological conditions, since it is now possible with the inventive system to obtain intracorporeal physiological information without the need for parenteral or invasive sampling. In other words, physiological information can be wirelessly tracked and monitored, allowing observation and supervision of metabolic and fertility activities, among others. This can even be done from a remote site, since the diagnostic data can be wirelessly transmitted to local hubs, local area networks, personal computers, and the internet. Thus, the inventive system can provide sophisticated diagnostic data to the user, to her physician, and to internet-hosted diagnostic services. Of particular significance is that this transfer of information is accomplished in real time.

[0012] Further specific features of the present invention will be explained in detail subsequently.

Brief Description of the Drawings

[0013] The features of the invention, and its technical advantages, can be seen from the following description of the preferred embodiments together with the claims and the accompanying drawings, in which:

Figs. 1 and 2 show the probe/transceiver and the controller/transceiver units respectively of the sys-

tem of the present invention;
 Fig. 3 shows the probe and controller units in a case;
 and
 Figs. 4-6 diagrammatically show the micro circuitry
 for various exemplary embodiments of the inventive
 probe and controller units.

Detailed Description of Preferred Embodiments

[0014] Referring now to the drawings in detail, the inventive system, which is designated generally by the reference numeral 20 (Fig. 3), essentially comprises two separate straightforward, self-contained units, namely a combination probe and transceiver 21 and a combination controller and transceiver 22. The required components of these units are integrated and, where appropriate, sealed into these two units. The bodies of the units 21, 22 are made of a plastic, such as those approved for medical use by the Food and Drug Administration. An example of such a plastic is medical grade level polycarbonate.

[0015] Although, as indicated previously, the inventive system 20 has numerous applications, including sensing or transducing vaginal conditions, affecting vaginal or body conditions, and/or stimulating perineal musculature and nerves, the system will now be explained in conjunction with use as a stimulation system.

[0016] When the system 20 is used as a stimulation system, the combination probe and transceiver unit is characterized as a stimulator unit. In one specific embodiment of the present invention such a stimulator unit is less than 2,5 cm (1 inch) in diameter and less than 10,2 cm (4 inches) in length. The end 24 of the unit 21 is rounded to facilitate vaginal insertion. The opposite end of the unit can be provided with, for example, an eyelet 25 to which a cord or similar device can be attached to facilitate removal of the reusable unit. The body of the unit is provided with at least one electrode ring 26 (two such rings are shown in the embodiment illustrated in Fig. 1), with these electrode rings being flush with the outer surface of the unit. The electrode rings 26 are designed to deliver electrical pulses to the muscles and/or nerves of the pelvic floor, and are preferably metallic rings, although they could also be made of non-metallic conducting material such as doped silicon. The stimulator unit 21 is furthermore provided with a microprocessor, a radio transmitter and a receiver mounted on a circuit board, an antenna and a sealed battery, as will be discussed in detail subsequently.

[0017] The operation of the combination probe and transceiver in its function as a stimulator unit will now be described by way of example. To begin a session, a woman would remove the hand-held combination controller and transceiver (the control unit) 22 and the stimulator unit 21 from the holder or case 28 (see Fig. 3), which also includes a tester 27 for the probe or stimulator unit. The stimulator unit 21 is then inserted into the vagina. The stimulator unit 21 can be turned on automatically at a low level when it is removed from the case 28; this can

be accomplished, for example, either by a signal from the control unit 22 or can be triggered by a non-illustrated magnet located in the case 28. Although automatic powering up is preferred, the stimulator unit 21 can also be turned on manually using the on/off button 30 of the control unit 22.

[0018] The stimulator unit 21 can operate entirely automatically by being preprogrammed. For example, the unit can start at a low level of about 2 volts, can hold this voltage for approximately 30 seconds or any other desired period of time, and can then automatically ramp up to, for example, 5 volts. The stimulator unit 21 could also be operated manually by the control unit 22, or the control unit could be used to override the programmed stimulator unit 21. For example, the hand-held control unit 22 can be used to increase the stimulation strength in small steps until a user feels the muscles contract. This would be accomplished by using the Increase button 31. Should the woman feel any discomfort, she can decrease the strength of stimulation by pushing the Decrease button 32, or can turn the system off by pushing the OFF button 30. The system can be programmed to run for a specified period of time, for example in fifteen minute cycles, after which it will automatically shut off. The stimulator unit 21 can then be removed.

[0019] During a session, which, as indicated above, could run for approximately 15 minutes, the stimulator unit 21 is programmed to follow a pattern of several stimulation cycles, each of which is followed by a rest period with a repeat of the set of stimulation cycles and rest periods. The stimulation patterns are the well known Kegel patterns. The stimulator unit 21 can be programmed so that it will automatically ramp up to the setting of a previous use; in other words, the stimulator unit and/or the control unit 22 is provided with a memory.

[0020] To accomplish the various functions of the system 20, namely of the control unit 22 and the stimulator or combination probe and transceiver unit 21, these units are provided with a number of components (see Fig. 4). In particular, the stimulator unit 21 and control unit 22 respectively include a battery 34 (which could be a rechargeable battery), a microprocessor 35, and a radio transmitter and receiver, or preferably a transceiver 36, 36' which includes an antenna. The radio transmitters and receivers, or transceivers, of the control unit 22 and of the probe unit 21 are miniature radio transceivers of the same low power class as of the known remote keyless locking devices used in automobiles. The programmable microprocessors of the units are designed to receive signals from the other unit and to deliver signals thereto, all in a wireless signal feedback loop, which may be closed or interactive. By way of example, electrical stimulation pulses can be delivered to the perineal musculature via the aforementioned electrode rings 26.

[0021] The control unit 22 and the probe unit 21 can also be provided with wireless means to transmit signals to or receive signals from external devices, networks or databases, including a PC which may be located in a

doctor's office, thereby facilitating data transmission and analysis.

[0022] It should also be noted that although the control unit 22 is preferably a hand-held unit, it could also be an appropriately programmed and equipped PC or the like.

[0023] As indicated above, the combination probe and transceiver unit 21 can be provided with means, such as one or more sensors with appropriate circuitry, for transducing vaginal conditions, delivering signals or medication, and/or stimulating perineal musculature and nerves. For this purpose, the combination probe and transceiver 21 is provided with the 2-way wireless communication means 36 for transmitting transduced information to the control unit 22, external devices, networks or databases and for receiving control and programming signals therefrom. Similarly, the control unit or combination controller and transceiver 22 is provided with wireless means, such as a transceiver 36', for sending wireless signals to the unit 21 and for receiving wireless signals therefrom. Thus, a wireless signal feedback loop is provided between the control unit 22 and the probe unit 21. Further inventive embodiments are illustrated in Figs. 5 and 6.

[0024] In particular, the combination controller and transceiver 22 can include means for altering the operational settings of the probe unit 21. The combination probe and transceiver 21 can be provided with sensing or transducing means 38 in the form of a muscle contraction sensor, and the unit 21 can also be provided with medication delivery means. In addition, the control unit 22 can be provided with means for altering stimulation signal levels and/or medication delivery signals.

[0025] The combination probe and transceiver unit 21 can also be provided with stimulating means (as in the embodiment of Fig. 4), which can be programmed to provide increasing stimulation and/or medication over a given period of time. The stimulating means can include means for automatic adjustment of stimulation levels in response to sensed muscle contractions and/or changes in the vaginal environment. Such stimulating means can be remotely adjustable, for example from the control unit 22 or from another source.

[0026] The combination probe and transceiver unit 21 can also be provided with means for sampling cervical fluid, and/or with means for sensing temperature, pH, secretion viscosity, vaginal pathogens and atypical cervical cells. The various sensors and transducers can be provided at any suitable location on the probe as long as the ergonomic character of the probe is maintained. Where appropriate, the sensors/transducers could even be in the form of the electrode rings 26.

[0027] As indicated previously, the combination probe and transceiver unit 21 is a sealed unit.

[0028] The present invention is, of course, in no way restricted to the specific disclosure of the specification and drawings, but also encompasses any modifications within the scope of the appended claims.

Claims

1. A system for at least one of transducing vaginal conditions, affecting vaginal or body conditions, and stimulating perineal musculature and nerves, in humans, said system comprising an insertable wireless probe and an internal power source, wherein said probe is a single, separate unit in the form of a portable, non-implanted, intravaginally containable combination probe (21), which integrates a transceiver (36) with an antenna, a programmable microprocessor and a power source (34) and is adapted to be inserted into the human vagina and is provided with means for at least one of sensing vaginal conditions, delivering signals or medication, and stimulating perineal musculature and nerves; wherein said combination probe (21), which integrates said transceiver (36), antenna, programmable microprocessor and power source (34), is provided with 2-way wireless communication means for transmitting information that is transduced and for receiving control and programming signals in real time; and a single, separate unit in the form of a combination controller (22) and another transceiver (36') that is provided with wireless means for sending signals to said probe (21) and for receiving signals therefrom; wherein a wireless signal feedback loop is provided in real time between said controller (22) and said probe (21) and which is an interactive or closed signal feedback wireless loop.
2. A system according to claim 1, **characterized in that** said controller (22) and said probe (21) are provided with means to transmit signals to and/or receive signals from an external device, network, and/or database wirelessly and in real time.
3. A system according to claim 2, **characterized in that** said probe (21) is provided with means for transducing in the form of a muscle contraction sensor, or in the form of means for sampling cervical fluid or other changes in the vaginal environment, or in the form of means for sensing at least one of temperature, pH, secretion viscosity, vaginal pathogens and atypical cervical cells.
4. A system according to any of claims 1-3, **characterized in that** said probe (21) is a sealed unit which is adapted to be inserted "in-situ" into the vaginal vault or removed therefrom, and **in that** said controller (22) and transceiver (36') is a hand-held unit.
5. A system according to any of claims 1-3, **characterized in that** said means of said controller (22) and transceiver (36') for sending signals includes means for wirelessly altering at least one of stimulation signal levels and medication delivery, and/or **in that** said probe (21) is provided with stimulating means

that includes means for automatic adjustment of stimulation levels in response to at least one of sensed muscle contractions and changes in the vaginal environment.

6. A system according to any of claims 1-5, **characterized in that** said probe (21) is provided with stimulating means, and **in that** said stimulating means is programmed to provide at least one of altering stimulation and medication delivery over a given period of time, wherein said stimulating means is remotely adjustable via a wireless signal.
7. A system according to any of claims 1-6, **characterized in that** said probe (21) is provided with at least one of at least one conductive band (26) and a sensor transducer (38).
8. A system according to any of claims 1-7, **characterized in that** said probe (21) is provided for being programmed at least one of at least one to start and/or stop sensing and/or stimulating after a predetermined period of time, to change its stimulating activity in response to sensed perineal muscle activity, to automatically change its stimulating activity over time, to stimulate perineal musculature and/or nerves in cycles of altering stimulation and rest periods.
9. A method for transducing and stimulating perineal musculature and/or nerves, in humans, said method comprising the steps of: activating a portable probe unit comprising a two-way transceiver (36) with antenna, a programmable microprocessor, and a power source (34); inserting the probe unit into the vagina, wherein said probe unit is adapted to stimulate pelvic muscles and /or nerves; controlling and programming signals to the probe unit from a separate controller unit disposed outside the vagina, providing the controller unit with two-way communication means adapted to both receive signals from the probe unit and transmit signals to the probe unit wirelessly and in real time, and providing an interactive or closed wireless signal feedback loop between said controller unit and said probe unit in real time during operation.
10. A method according to claim 9, **characterized in that** the probe unit adapted thereto will automatically cease or change its stimulating activity after a predetermined period of time.

Patentansprüche

1. System für mindestens eines von Aufnehmen vaginaler Beschwerden, Beeinflussen vaginaler oder körperlicher Beschwerden und Stimulieren von

Dammuskulatur und -nerven bei Menschen, wobei das System eine einsetzbare Funksonde und eine interne Energiequelle umfasst, wobei die Sonde eine einzelne separate Einheit in der Form einer tragbaren, nicht implantierten, intravaginal aufnehmbaren Kombinationssonde (21) ist, die einen Sender-Empfänger (36) mit einer Antenne, einem programmierbaren Mikroprozessor und einer Energiequelle (34) integriert und zum Einsetzen in die menschliche Vagina ausgebildet ist und mit Mitteln für mindestens eines von Erfassen vaginaler Beschwerden, Abgeben von Signalen oder Medikation und Stimulieren von Dammuskulatur und -nerven bereitgestellt ist; wobei die Kombinationssonde (21), die den Sender-Empfänger, die Antenne, den programmierbaren Mikroprozessor und die Energiequelle (34) integriert, bereitgestellt ist mit einem Zweiweg-Funkkommunikationsmittel zum Senden von Informationen, die aufgenommen werden, sowie zum Empfangen von Steuer- und Programmierungssignalen in Echtzeit, und einer einzelnen separaten Einheit in der Form eines Kombinationssteuergerätes (22) und einem anderen Sender-Empfänger (36'), der mit einem Funkmittel zum Senden von Signalen zu der Sonde (21) und zum Empfangen von Signalen von dieser bereitgestellt ist; wobei eine Funksignalrückkopplungsschleife in Echtzeit zwischen dem Steuergerät (22) und der Sonde (21) bereitgestellt ist, die eine interaktive oder geschlossene Signalrückkopplungsfunktschleife ist.

2. System nach Anspruch 1, **dadurch gekennzeichnet, dass** das Steuergerät (22) und die Sonde (21) mit einem Mittel zum Senden und/oder Empfangen von Signalen zu beziehungsweise von einer externen Vorrichtung, einem Netzwerk und/oder einer Datenbank in Echtzeit und über Funk bereitgestellt ist.
3. System nach Anspruch 2, **dadurch gekennzeichnet, dass** die Sonde (21) mit einem Aufnahmemittel in der Form eines Muskelkontraktionssensors oder in der Form eines Mittels zur Probennahme von Zervikalschleim oder anderen Veränderungen in der vaginalen Umgebung oder in der Form eines Mittels zum Erfassen mindestens eines von Temperatur, pH-Wert, Sekretionsviskosität, vaginaler Pathogene und atypischer Zervikalzellen bereitgestellt ist.
4. System nach einem der Ansprüche 1 bis 3, **dadurch gekennzeichnet, dass** die Sonde (21) eine versiegelte Einheit ist, die dazu ausgebildet ist, "in situ" in das Scheidengewölbe eingeführt oder von diesem entfernt zu werden, und dass das Steuergerät (22) und der Sender-Empfänger (36') eine tragbare Einheit ist.
5. System nach einem der Ansprüche 1 bis 3, **dadurch**

gekennzeichnet, dass das Mittel des Steuergerätes (22) und des Sender-Empfängers (36') zum Senden von Signalen ein Mittel zum Verändern über Funk mindestens eines von Stimulierungspegeln und Medikationsabgabe enthält und/oder dass die Sonde (21) mit einem Stimulierungsmittel bereitgestellt ist, das ein Mittel zur automatischen Einstellung von Stimulierungspegeln als Reaktion auf mindestens einer von erfassten Muskelkontraktionen und Veränderungen in der vaginalen Umgebung enthält.

6. System nach einem der Ansprüche 1 bis 5, **dadurch gekennzeichnet, dass** die Sonde (21) mit einem Stimulierungsmittel bereitgestellt ist und dass das Stimulierungsmittel so programmiert ist, dass es mindestens eines von einer Veränderung der Stimulierung und Medikationsabgabe über eine bestimmte Zeitperiode bereitstellt, wobei das Stimulierungsmittel über ein Funksignal ferneinstellbar ist.
7. System nach einem der Ansprüche 1 bis 6, **dadurch gekennzeichnet, dass** die Sonde (21) mit mindestens einem von mindestens einem leitfähigen Band (26) und einem Sensorwandler (38) bereitgestellt ist.
8. System nach einem der Ansprüche 1 bis 7, **dadurch gekennzeichnet, dass** die Sonde (21) vorgesehen ist zum Programmieren von mindestens einer von mindestens einer von einer Start- und/oder Stopp-Erfassung und/oder Stimulierung nach einer bestimmten Zeitperiode, zum Ändern ihrer Stimulierungsaktivität als Reaktion auf eine erfasste Damm-muskelaktivität, zum automatischen Ändern ihrer Stimulierungsaktivität im Laufe der Zeit, zum Stimulieren von Dammmuskulatur und/oder -nerven in Zyklen von abwechselnden Stimulierungs- und Ruheperioden.
9. Verfahren zum Aufnehmen und Stimulieren von Dammmuskulatur und -nerven bei Menschen, wobei das Verfahren die folgenden Schritte umfasst: Aktivieren einer tragbaren Sondeneinheit, umfassend einen Zweiweg-Sender-Empfänger (36) mit einer Antenne, einem programmierbaren Mikroprozessor und einer Energiequelle (34); Einsetzen der Sondeneinheit in die Vagina, wobei die Sondeneinheit dazu ausgebildet ist, Beckenmuskeln und/oder -nerven zu stimulieren; Steuern und Programmieren von Signalen zu der Sondeneinheit von einer separaten Steuereinheit, die außerhalb der Vagina angeordnet ist, Bereitstellen der Steuereinheit mit einem Zweiweg-Kommunikationsmittel, das dazu ausgebildet ist, über Funk und in Echtzeit sowohl Signale von der Sondeneinheit zu empfangen, wie auch Signale zu der Sondeneinheit zu senden, und Bereitstellen einer interaktiven oder geschlossenen Funksignalkopplungsschleife zwischen der Steuereinheit

und der Sondeneinheit in Echtzeit während des Betriebs.

10. Verfahren nach Anspruch 9, **dadurch gekennzeichnet, dass** die Sondeneinheit, die dazu ausgebildet ist, automatisch ihre Stimulierungsaktivität nach einer vorbestimmten Zeitperiode beenden oder ändern wird.

Revendications

1. Système destiné à transduire les conditions vaginales, et/ou à modifier les conditions vaginales ou corporelles, et/ou à stimuler les systèmes musculaire et nerveux périnéaux, chez les humains, ledit système comprenant une sonde sans fil insérable et une source d'énergie interne, ladite sonde étant une unité distincte et unique sous la forme d'une sonde combinée pouvant être contenue à l'intérieur du vagin, portable et non implantée (21), qui intègre un émetteur-récepteur (36) avec une antenne, un microprocesseur programmable et une source d'énergie (34) et est adaptée pour être insérée dans le vagin humain et est dotée d'un moyen destiné à détecter les conditions vaginales, et/ou à délivrer des signaux ou des médicaments, et/ ou à stimuler les systèmes musculaire et nerveux périnéaux ; ladite sonde combinée (21), qui intègre ledit émetteur-récepteur (36), ladite antenne, ledit microprocesseur programmable et ladite source d'énergie (34), étant dotée d'un moyen de communication sans fil bidirectionnel destiné à transmettre les informations transduites et à recevoir les signaux de commande et de programmation en temps réel ; et une unité distincte et unique sous la forme d'un régulateur combiné (22) et un autre émetteur-récepteur (36') qui est doté d'un moyen sans fil destiné à envoyer des signaux à ladite sonde (21) et à recevoir des signaux de celle-ci ; une boucle de rétroaction de signal sans fil étant prévue en temps réel entre ledit régulateur (22) et ladite sonde (21) et qui est une boucle de rétroaction de signal interactive ou fermée, sans fil.
2. Système selon la revendication 1, **caractérisé en ce que** ledit régulateur (22) et ladite sonde (21) sont dotés d'un moyen de transmission des signaux et/ou de réception des signaux d'un dispositif, réseau et/ou base de données externes sans fil et en temps réel.
3. Système selon la revendication 2, **caractérisé en ce que** ladite sonde (21) est dotée d'un moyen de transduction sous la forme d'un détecteur de contractions musculaires, ou sous la forme d'un moyen d'échantillonnage de fluide cervical ou autres modifications dans l'environnement vaginal, ou sous la forme d'un moyen de détection de la température,

- et/ou du pH, et/ou de la viscosité des sécrétions, et/ou des pathogènes vaginaux, et/ou des cellules cervicales atypiques.
4. Système selon l'une quelconque des revendications 1 à 3, **caractérisé en ce que** ladite sonde (21) est une unité scellée qui est adaptée pour être insérée « in situ » dans le, ou retirée du, dôme vaginal, et **en ce que** ledit régulateur (22) et ledit émetteur-récepteur (36') est une unité manuelle. 5
10
5. Système selon l'une quelconque des revendications 1 à 3, **caractérisé en ce que** ledit moyen dudit régulateur (22) et dudit émetteur-récepteur (36') destiné à envoyer des signaux comprend un moyen de modification sans fil des niveaux des signaux de stimulation et/ou de la délivrance de médicament, et/ou **en ce que** ladite sonde (21) est dotée d'un moyen de stimulation qui comprend un moyen d'ajustement automatique des niveaux de stimulation en réponse aux contractions musculaires détectées et/ou aux modifications de l'environnement vaginal. 15
20
6. Système selon l'une quelconque des revendications 1 à 5, **caractérisé en ce que** ladite sonde (21) est dotée d'un moyen de stimulation, et **en ce que** ledit moyen de stimulation est programmé pour fournir une stimulation changeante et/ou une délivrance de médicament changeante sur une période de temps donnée, ledit moyen de stimulation pouvant être ajusté à distance via un signal sans fil. 25
30
7. Système selon l'une quelconque des revendications 1 à 6, **caractérisé en ce que** ladite sonde (21) est dotée d'une bande conductrice (26) et/ou d'un détecteur-émetteur-récepteur (38). 35
8. Système selon l'une quelconque des revendications 1 à 7, **caractérisé en ce que** ladite sonde (21) est fournie pour être programmée pour débiter et/ou mettre un terme à la détection, et/ou pour stimuler après une période de temps prédéterminée, et/ou pour modifier son activité de stimulation en réponse à une activité détectée des muscles périnéaux, et/ou pour automatiquement modifier son activité de stimulation dans le temps, et/ou pour stimuler les systèmes musculaire et/ou nerveux périnéaux en cycles de stimulation changeantes et de périodes de repos. 40
45
9. Procédé de transduction et de stimulation des systèmes musculaire et/ou nerveux périnéaux, chez les humains, ledit procédé comprenant les étapes consistant à : 50
- activer une unité de sonde portable comprenant un émetteur-récepteur bidirectionnel (36) avec une antenne, un microprocesseur programmable, et une source d'énergie (34) ; insérer l'unité 55
- de sonde dans le vagin, ladite unité de sonde étant adaptée pour stimuler les muscles et/ou les nerfs pelviens ;
commander et programmer les signaux à l'unité de sonde d'une unité de régulateur distincte disposée hors du vagin, doter l'unité de régulateur d'un moyen de communication bidirectionnel pour recevoir les signaux de l'unité de sonde et pour transmettre les signaux à l'unité de sonde sans fil et en temps réel, et fournir une boucle de rétroaction de signaux sans fil interactive ou fermée entre ladite unité de régulateur et ladite unité de sonde en temps réel durant le fonctionnement.
10. Procédé selon la revendication 9, **caractérisé en ce que** l'unité de sonde adaptée à celui-ci cessera ou modifiera automatiquement son activité de stimulation après une durée prédéterminée.

FIG 1

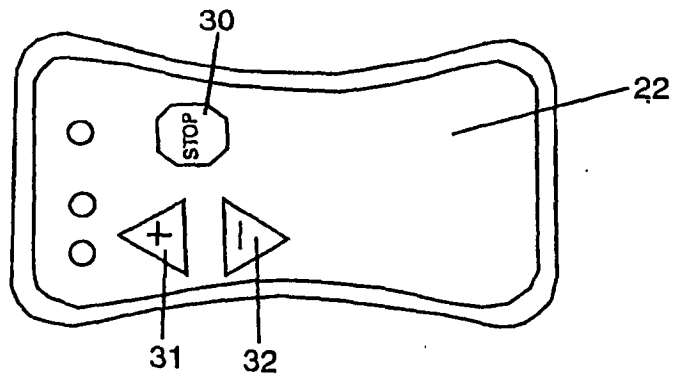
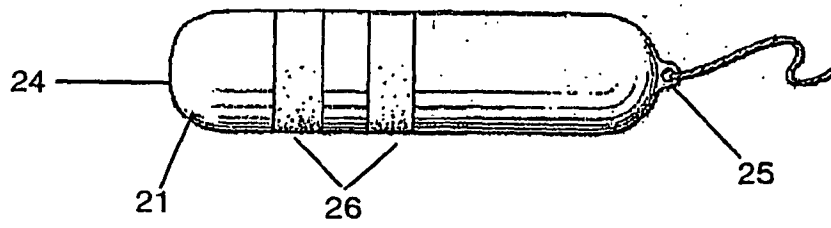
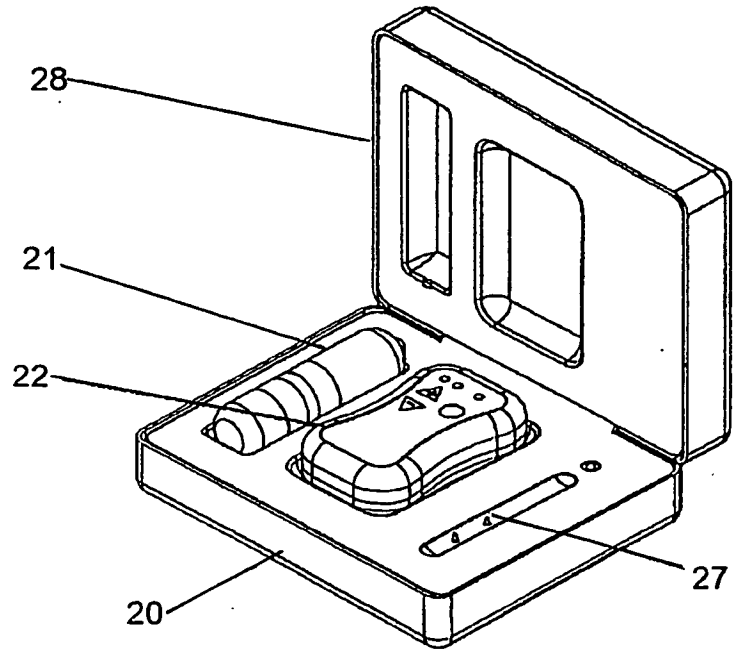

FIG 2

FIG 3



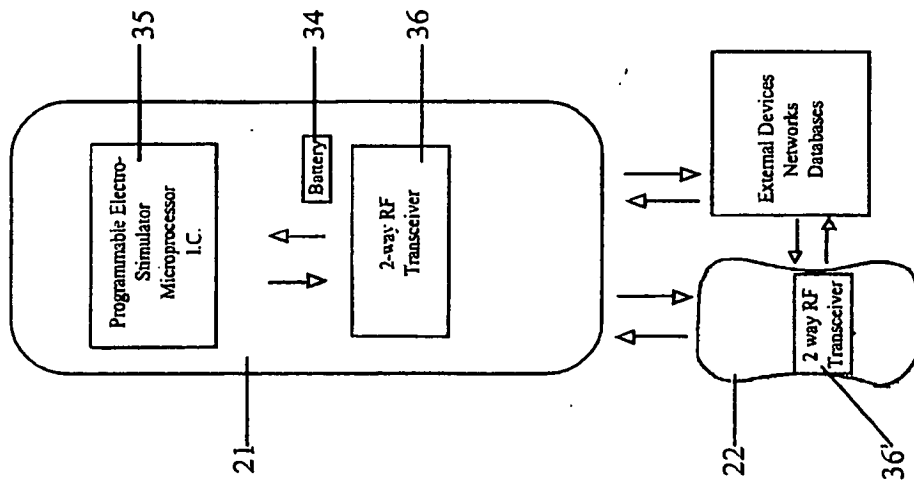

FIG. 4

FIG 5

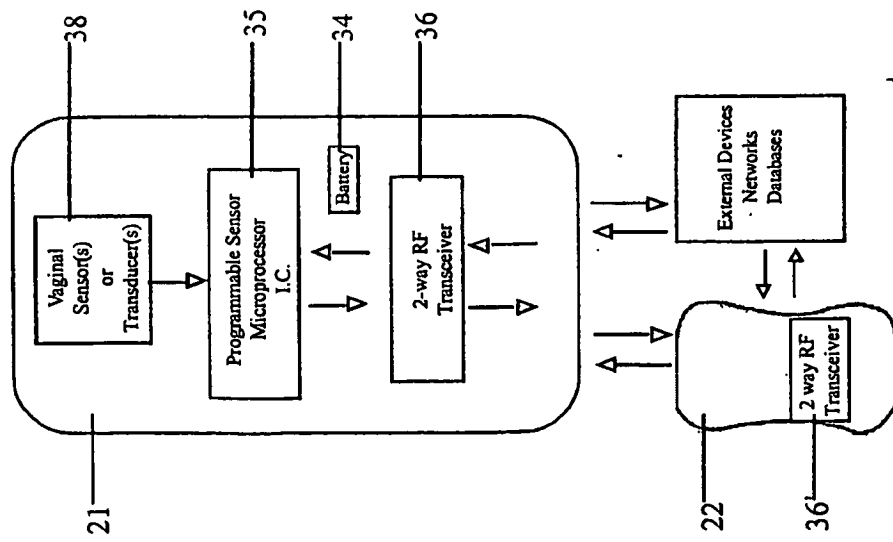
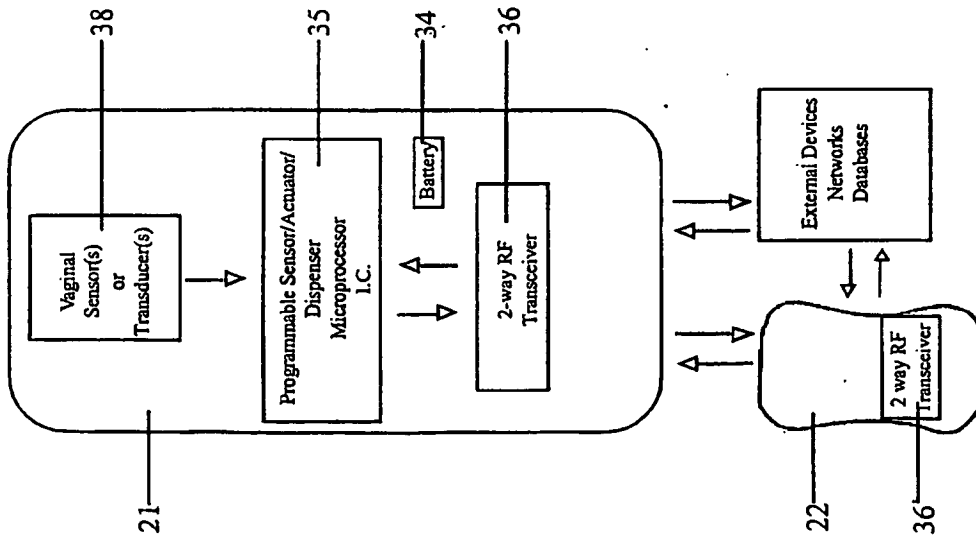

FIG 6



REFERENCES CITED IN THE DESCRIPTION

This list of references cited by the applicant is for the reader's convenience only. It does not form part of the European patent document. Even though great care has been taken in compiling the references, errors or omissions cannot be excluded and the EPO disclaims all liability in this regard.

Patent documents cited in the description

- US 4515167 A, Hochman [0002]
- US D393311 S [0003]
- US 5916173 A, Kirsner [0003]
- US 4753247 A, Kirsner [0003]
- WO 0023030 A, Gafni and Cohen [0004]

专利名称(译)	使用双向无线通信进行阴道感知和刺激		
公开(公告)号	EP1487335B1	公开(公告)日	2010-10-20
申请号	EP2002784285	申请日	2002-10-24
[标]申请(专利权)人(译)	雅典娜费米尼技术有限公司		
申请(专利权)人(译)	ATHENA FEMININE TECHNOLOGIES, INC.		
当前申请(专利权)人(译)	ATHENA FEMININE TECHNOLOGIES, INC.		
[标]发明人	HOCHMAN JOEL S SARKIS GEORGE		
发明人	HOCHMAN, JOEL, S. SARKIS, GEORGE		
IPC分类号	A61B5/103 A61B A61B5/00 A61N1/36		
CPC分类号	A61B5/0002 A61B5/01 A61B5/04 A61B5/14539 A61B5/227 A61B5/4337 A61B10/0045 A61B2010/0019 A61B2010/0022 A61B2010/0074 A61B2562/242 A61H2201/5097 A61N1/0524 A61N1/36007		
其他公开文献	EP1487335A1 EP1487335A4		
外部链接	Espacenet		

摘要(译)

提供了一种系统和方法，用于转导阴道病症，影响阴道或身体状况，和/或刺激会阴肌肉组织和神经。提供了单独的，便携式，非植入的阴道内可容纳的组合探针和收发器，其可以感测阴道状况，可以递送信号或药物，和/或可以刺激会阴肌肉组织和神经。该探测单元具有双向无线通信，用于发送被转换的信息以及用于接收控制和编程信号的信息。另外，提供单独的组合控制器和收发器，用于无线地向探测器单元发送信号并从其接收信号。因此，在控制器和探针和/或外部设备，网络和数据库之间提供实时无线信号反馈回路。

