



(11) **EP 1 418 833 B1**

(12) **EUROPEAN PATENT SPECIFICATION**

(45) Date of publication and mention of the grant of the patent:  
**13.08.2008 Bulletin 2008/33**

(51) Int Cl.:  
**A61B 5/07 (2006.01) A61B 1/00 (2006.01)**  
**A61B 5/00 (2006.01) H05K 1/00 (2006.01)**

(21) Application number: **02738602.8**

(86) International application number:  
**PCT/IL2002/000480**

(22) Date of filing: **18.06.2002**

(87) International publication number:  
**WO 2002/102224 (27.12.2002 Gazette 2002/52)**

(54) **SWALLOWABLE IN VIVO SENSING CAPSULE WITH A CIRCUIT BOARD HAVING RIGID SECTIONS AND FLEXIBLE SECTIONS**

SCHLUCKBARE IN VIVO-ERFASSUNGSKAPSEL MIT EINER STARRE UND FLEXIBLE ABSCHNITTE AUFWEISENDEN LEITERPLATTE

CAPSULE À AVALER AVEC UNE DISPOSITIF DE DETECTION IN VIVO COMPORTANT UNE CARTE DE CIRCUITS IMPRIMÉS POURVUE DE SECTIONS RIGIDES ET DE SECTIONS FLEXIBLES

(84) Designated Contracting States:  
**AT BE CH CY DE DK ES FI FR GB GR IE IT LI LU MC NL PT SE TR**

(56) References cited:  
**EP-A- 1 104 182 US-A- 3 791 377**  
**US-A- 4 741 327 US-A- 4 742 817**  
**US-A- 4 803 992 US-A- 4 860 732**  
**US-A- 5 078 134 US-A- 5 725 474**  
**US-A- 5 807 266 US-A- 5 833 603**  
**US-B1- 6 313 456**

(30) Priority: **18.06.2001 US 298387 P**

(43) Date of publication of application:  
**19.05.2004 Bulletin 2004/21**

(73) Proprietor: **Given Imaging Ltd.**  
**20692 Yoqneam (IL)**

(72) Inventor: **AVNI, Dov**  
**34525 Haifa (IL)**

(74) Representative: **Siegert, Georg**  
**Hoffmann - Eitle**  
**Patent- und Rechtsanwälte**  
**Arabellastrasse 4**  
**81925 München (DE)**

- **GAVRIEL D. MERON: "THE DEVELOPMENT OF THE SWALLOWABLE VIDEO CAPSULE (M2A)" GASTROINTESTINAL ENDOSCOPY, vol. 52, no. 6, December 2000 (2000-12), pages 817-819, XP008041293 ELSEVIER, NL**
- **APPLEYARD ET AL: "A randomized trial comparing wireless capsule endoscopy with push enteroscopy for the detection of small-bowel lesions" GASTROENTEROLOGY, vol. 119, no. 6, December 2000 (2000-12), pages 1431-1438, XP005688749 USA**

**EP 1 418 833 B1**

Note: Within nine months of the publication of the mention of the grant of the European patent in the European Patent Bulletin, any person may give notice to the European Patent Office of opposition to that patent, in accordance with the Implementing Regulations. Notice of opposition shall not be deemed to have been filed until the opposition fee has been paid. (Art. 99(1) European Patent Convention).

**Description****FIELD OF THE INVENTION**

**[0001]** The present invention relates to an in vivo imaging device and system such as for imaging the digestive tract.

**BACKGROUND OF THE INVENTION**

**[0002]** In vivo imaging may include the use of an in vivo imager from which image data may be transmitted to an external receiving system. For example, an ingestible capsule comprising an image sensor and a transmitter for transmitting image data may be used for imaging the gastrointestinal (GI) tract. In some ingestible capsules the electronic components within the capsule may be arranged on several boards, each board containing different components of the capsule, for example, the image sensor, typically a silicon chip, may be positioned on one board whereas the transmitter may be positioned on a separate printed circuit board (PCB). In some cases the boards are aligned along an axis of the capsule and are electrically connected by a plurality of wires. Assembly of capsules having several boards connected by wires may be complex and may hinder, for example, large scale production.

**[0003]** The report "The development of the swallowable video capsule (M2A)" by Gavriel D. Meron, Gastrointestinal endoscopy, vol. 52, no. 6, 2000, pages 817-819 describes the history of the development of a capsule endoscope at Given Imaging Limited. Among other things, it mentions the presentation of a capsule at the plenary session of the AGE on May 24, 2000.

**[0004]** The Article "A randomized trial comparing wireless capsule endoscopy with push enteroscopy for the detection of small-bowel lesions", by Mark Appleyard et al, Gastroenterology, 2000; vol. 119: 1431-1438 describes a capsule endoscope as well as results of using such a capsule endoscope.

**[0005]** US-3,791,377 describes a radio capsule battery in which a silver-silver chloride electrode functions as the reference electrode for a sensor by means of an electrolytic path from the battery chamber to the solution external to the capsule. The radio capsule comprises a battery chamber, a sensing electrode, an oscillator circuit, and an oscillator coil functioning as a transmitting antenna. The battery chamber is at one end of the capsule, and the coil is at the other. Between the battery chamber and coil two disks-shaped circuit boards are arranged, between which the oscillator circuit is provided. Furthermore, a silver wire that forms part of the silver-silver chloride electrode in the battery chamber extends through the first circuit board and contacts the other circuit board for forming an electrical connection between the two circuit boards.

**[0006]** US-4,803, 992 describes electro optical instruments, among them a medical instrument in the form of

a capsule to be ingested by swallowing and operable for sensing one or more physiological variables. The device includes electrical and optical means supported within a housing. Centrally supported across and between opposite wall portions of the housing is an electrical assembly including a circuit board defining a flat multilayer rectangular substrate containing a thin disk-shaped battery secured thereto, and connected for electrically energizing and powering circuit elements supported by the substrate.

**[0007]** EP-1 104 182 A1 describes an image sensor device for incorporation into endoscopes. More specifically, the document is specifically concerned with distal imaging endoscopes and the question of arranging an image sensor device in such an endoscope. According to the document, a printed circuit board is used that comprises rigid portions and flexible elements. The printed circuit board has one section carrying the imaging device, and a second section that is bent relative to the first section.

**Summary of the invention**

**[0008]** In accordance with claim 1, the present application relates to an in-vivo sensing device in the form of a swallowable in-vivo sensing capsule that comprises a circuit board with at least two rigid sections and a flexible section connecting the two rigid sections, and with one or more batteries positioned between the two rigid sections. Advantageous embodiments are described in the dependent claims.

**[0009]** Thus, the present invention provides, according to some embodiments an in vivo sensing device comprising a circuit board having a plurality of rigid sections and a plurality of flexible sections. According to one embodiment the rigid sections and flexible sections alternate. Optionally, the in vivo sensing device may include at least an image sensor. According to another embodiment the device may also include a transmitter for transmitting signals from a sensor, such as an imaging camera, to a receiving system. In one embodiment various components in the device, such as the image sensor and transmitter, are disposed on different rigid circuit board sections. Preferably, the circuit board is folded and arranged in a stacked vertical fashion. In a further embodiment, the various rigid portions may be connected by vertical connectors such as springs.

**BRIEF DESCRIPTION OF THE DRAWINGS**

**[0010]** The present invention will be understood and appreciated more fully from the following detailed description taken in conjunction with the drawings in which:

Figure 1 schematically illustrates an in vivo imaging device according to one embodiment of the invention;  
Figures 2A and 2B schematically illustrate possible

folding of the circuit board according to two embodiments of the invention; and

Figure 3 schematically illustrates an in vivo imaging device according to a third embodiment of the invention.

## DETAILED DESCRIPTION OF THE INVENTION

**[0011]** In the following description, various aspects of the present invention will be described. For purposes of explanation, specific configurations and details are set forth in order to provide a thorough understanding of the present invention. However, it will also be apparent to one skilled in the art that the present invention may be practiced without the specific details presented herein. Furthermore, well-known features may be omitted or simplified in order not to obscure the present invention.

**[0012]** The system and method of the present invention may be used with an imaging system such as that described in WO 01/65995. A further example of an imaging system with which the system and method of the present invention may be used is described in U.S. Patent No. 5,604,531 to Iddan et al. Both these publications are assigned to the common assignee of the present application

**[0013]** Reference is now made to Fig. 1, which schematically illustrates an in vivo imaging device according to an embodiment of the invention. The device 10 typically comprises an optical window 21 and an imaging system for obtaining images from inside a body lumen, such as the GI tract. The imaging system includes an illumination source 23, such as a white LED, a CMOS imaging camera 24, which detects the images and an optical system 22 which focuses the images onto the CMOS image sensor 24. The illumination source 23 illuminates the inner portions of the body lumen through optical window 21. Device 10 further includes a transmitter 26 and an antenna 27 for transmitting image signals from the CMOS image sensor 24, and a power source 25, such as a silver oxide battery, that provides power to the electrical elements of the device 10. A suitable CMOS image sensor 24 is, for example, a "camera on a chip" type CMOS imager specified by Given Imaging Ltd. of Yokneam, Israel and designed by Photobit Corporation of California, USA. The single chip camera can provide either black and white or color signals. A suitable transmitter, may comprise a modulator which receives the image signal (either digital or analog) from the CMOS imaging camera, a radio frequency (RF) amplifier, an impedance matcher and an antenna. A processor, e.g., for processing the image data may be included in the device. The processor or processing circuitry may be integrated in the sensor or in the transmitter.

**[0014]** The device 10 is capsule shaped and can operate as an autonomous endoscope for imaging the GI tract.

**[0015]** According to one embodiment of the invention, the various components of the device 10 are disposed

on a circuit board including rigid and flexible portions; preferably the components are arranged in a stacked vertical fashion. For example, one rigid portion 31 of the circuit board may hold a transmitter and an antenna; preferably the antenna is at one end of the capsule to avoid screening of the signal by metal or other components in the capsule. Another rigid portion 33 of the circuit board includes an LED 23 lighting system and an imager 24 on one side; the other side of this rigid portion 33 includes a battery 25 contact. The battery contact is preferably a spring, described below. Another rigid portion 35 of the circuit board includes another battery contact. Each rigid portion of the circuit board is connected to another rigid portion of the circuit board by a flexible connector portion (e.g. 32 and 32') of the circuit board. Preferably, each rigid portion of the circuit board comprises two rigid sections; sandwiched between the rigid sections is a flexible connector portion of the circuit board for connecting the rigid boards. In alternate embodiments, other arrangements of components may be placed on a circuit board having rigid portions connected by flexible portions.

**[0016]** In alternate embodiments, a circuit board having rigid portions and flexible portions may be used to arrange and hold components in other in vivo sensing devices, such as a swallowable capsule measuring acidity (having a pH sensor (, temperature or pressure, or in a swallowable imaging capsule having components other than those described above.

**[0017]** Preferably, each flexible connector portion is equal to or less than 4/1000 inch (4 mils) in thickness. Preferably, electrical connection is made from the outside portion of a rigid portion board (on which components are mounted) to the inside of the rigid portion and to the flexible portion contained within, by a small (equal to or less than 4 mils in diameter) hole leading from the outside portion to the flexible portion - a micro-via. Preferably the micro-via is created using a laser. Companies providing such flexible connector and micro-via technology are Eltech, of Petach-Tikva, Israel, and Ilfa, of Germany. In alternate embodiments, other types of rigid sections and flexible sections may be used to create a circuit board.

**[0018]** The circuit board may be folded, for example, as shown in Figs. 2A and 2B. When folded, the battery contacts contact a set of one or more batteries, which are sandwiched between two rigid circuit board portions. The circuit board may be folded in various manners. For example, Fig. 2A schematically shows a circuit board, according to an embodiment of the invention, arranged as an "S" with rigid portions 31, 35 and 33 and alternating flexible portions 32 and 32'. A set of batteries 25 may be sandwiched between one lobe 38 of the S. Another configuration, according to an embodiment of the invention is schematically shown in Fig. 2B. The circuit board, according to an embodiment of the invention may be in the shape of a "6" with rigid portions 31, 35 and 33 and alternating flexible portions 34 and 3.4. A set of batteries 25 may be positioned in the closed configuration 38' of the "6".. Other configurations are possible. In alternate

embodiments, batteries may be connected in different manners.

**[0019]** Preferably, a very thin flexible section is needed due to the radius of the diameter of the turns, given the size of the capsule, and also because the flexible section may be disposed between components, such as between the set of batteries and the side of the capsule. Preferably, the radius of the turn should be more than 6 or 10 times the thickness. In alternate embodiments, the rigid boards and flexible connectors may be of other dimensions.

**[0020]** In one embodiment, the rigid portions of the circuit board may include any sort of known material; preferably FR4 flexiglass is used. The flexible portions may include any sort of known material; preferably, Kapton™ by DuPont is used.

**[0021]** Reference is made to Figure 3, which schematically illustrates another view of an embodiment of the invention. According to one embodiment, a vertical physical and electrical connection may be made between rigid portions of the circuit board. For example, the rigid portion 51 holding the LED 23 (which is preferably in the shape of a ring) may be connected physically and electrically to another rigid portion apart from being connected by flexible portion 57. In one embodiment, mini springs 56 are used to connect a power supply from one circuit rigid portion 53 to the rigid portion 51 holding the LED 23. Such springs 56 have two functions; to mechanically connect the two rigid portions (e.g., 51 and 53) and also to conduct current between the two rigid portions. Preferably, the springs are glued to the two rigid portions, and current flows between two rigid portions.

**[0022]** In addition, a vertical connection is made between the set of batteries 25 and two rigid portions by springs 58. Each contact spring 58 is preferably a conical spring, which, as it shrinks, allows each circle or coil of the spring to enter a larger encircling coil. Thus, when fully shrunken, the final thickness of the spring is thickness of a single circle of conductor wire.

**[0023]** There is also provided a method for the manufacture of an in vivo sensor, in accordance with an embodiment of the invention. The method includes the steps of disposing at least a sensor on a rigid section of a circuit board having a plurality of rigid sections and a plurality of flexible sections and folding the circuit board into a housing configured for in vivo sensing.

**[0024]** It will be appreciated by persons skilled in the art that the present invention is not limited to what has been particularly shown and described hereinabove. Rather the scope of the present invention is defined only by the claims which follow:

## Claims

1. A swallowable in vivo sensing capsule (10) comprising:

a circuit board that comprises at least two rigid sections (33, 35) and a flexible section (32') connecting said two rigid sections (33, 35), and one or more batteries (25) positioned between the two rigid sections (33, 35).

2. The capsule according to claim 1, further comprising one of a pH sensor, a temperature sensor, an image sensor (24) and a pressure sensor.

3. The capsule according to one of claims 1 or 2, further comprising a transmitter (26).

4. The capsule according to claim 1, further comprising at least one component selected from the group consisting of an illumination source (23), a sensor (24), a processor, a transmitter (26) or a combination thereof.

5. The capsule according to claim 4 wherein at least one component is disposed on at least one of said rigid sections of the circuit board.

6. The capsule according to claim 5, wherein said at least one component is electrically connected through micro-via in the rigid section.

7. The capsule according to claim 1, further comprising a sensor (24) and a transmitter (26), wherein the sensor (24) is disposed on a first rigid section (33) of the circuit board and the transmitter (26) is disposed on another rigid section (31) of the circuit board.

8. The capsule according to one of claims 1 to 7, wherein a plurality of flexible sections is provided and the rigid sections alternate with the flexible sections.

9. The capsule according to claim 1, wherein the circuit board is folded such that the rigid sections of the circuit board are stacked vertically.

10. The capsule according to claim 1, wherein the rigid sections are connected by vertical connectors.

11. The capsule according to claim 10, wherein the vertical connectors are electrical conductors.

12. The capsule according to claim 10 or 11, wherein the vertical connectors are springs (56, 58).

13. The capsule according to claim 12 wherein the springs (56, 58) are conical springs.

14. The capsule according to one of claims 1 to 13, wherein the circuit board includes flexiglass.

15. The capsule device according to one of claims 1 to

14, one or both of said rigid sections (33, 35) including a battery contact.

16. A method for the manufacture of an in vivo capsule comprising the steps of:

disposing at least a sensor on a rigid section of a circuit board that comprises at least two rigid sections (33, 35) and a flexible section (32') connecting said two rigid sections (33, 35), and folding the circuit board into a housing configured for in vivo sensing, including positioning one or more batteries (25) between the two rigid sections (33, 35).

17. The method of claim 16, wherein the step of folding the circuit board includes folding the circuit board such that the rigid sections of the circuit board are stacked vertically.

### Patentansprüche

1. Eine schluckbare In-Vivo-Detektierkapsel (10), umfassend:

eine Schaltungsplatte, die mindestens zwei starre Abschnitte (33, 35) und einen flexiblen, die zwei starren Abschnitte (33, 34) verbindenden Abschnitt (32') umfasst, und eine oder mehrere zwischen den zwei starren Abschnitten (33, 35) positionierte Batterien (25).

2. Die Kapsel nach Anspruch 1, ferner umfassend eines aus der Gruppe von pH-Sensor, Temperatursensor, Bildsensor (24) und Drucksensor.

3. Die Kapsel nach einem der Ansprüche 1 oder 2, ferner umfassend einen Sender (26).

4. Die Kapsel nach Anspruch 1, ferner umfassend mindestens eine Komponente, die ausgewählt wird aus der Gruppe bestehend aus einer Beleuchtungsquelle (23), einem Sensor (24), einem Prozessor, einem Sender (26) oder einer Kombination davon.

5. Die Kapsel nach Anspruch 4, wobei mindestens eine Komponente angeordnet ist auf mindestens einem der starren Abschnitte der Schaltungsplatte.

6. Die Kapsel nach Anspruch 5, wobei die mindestens eine Komponente elektrisch verbunden ist durch Mikro-Via in dem starren Abschnitt.

7. Die Kapsel nach Anspruch 1, ferner umfassend einen Sensor (24) und einen Sender (26), wobei der Sensor (24) auf einem ersten starren Abschnitt (33) der Schaltungsplatte angeordnet ist und der Sender

(26) auf einem anderen starren Abschnitt (31) der Schaltungsplatte angeordnet ist.

8. Die Kapsel nach einem der Ansprüche 1 bis 7, wobei eine Vielzahl von flexiblen Abschnitten bereitgestellt wird, und die starren Abschnitte sich mit den flexiblen Abschnitten abwechseln.

9. Die Kapsel nach Anspruch 1, wobei die Schaltungsplatte derart gefaltet ist, dass die starren Abschnitte der Schaltungsplatte vertikal aufeinander gestapelt sind.

10. Die Kapsel nach Anspruch 1, wobei die starren Abschnitte durch vertikale Verbinder verbunden sind.

11. Die Kapsel nach Anspruch 10, wobei die vertikalen Verbinder elektrische Leiter sind.

12. Die Kapsel nach Anspruch 10 oder 11, wobei die vertikalen Verbinder Federn (56, 58) sind.

13. Die Kapsel nach Anspruch 12, wobei die Federn (56, 58) Kegelfedern sind.

14. Die Kapsel nach einem der Ansprüche 1 bis 13, wobei die Schaltungsplatte Flexiglas enthält.

15. Das Kapselgerät nach einem der Ansprüche 1 bis 14, wobei ein oder beide der starren Abschnitte (33, 35) einen Batteriekontakt enthält/enthalten.

16. Ein Verfahren zur Herstellung einer In-Vivo-Kapsel, umfassend die Schritte:

Anordnen von mindestens einem Sensor auf einem starren Abschnitt einer Schaltungsplatte, die mindestens zwei starre Abschnitte (33, 35) und einen die zwei starren Abschnitte (33, 34) verbindenden flexiblen Abschnitt (32'), umfasst, und Falten der Schaltungsplatte in ein Gehäuse, das konfiguriert ist für ein In-Vivo-Detektieren, einschließlich einem Positionieren von einer oder mehreren Batterien (25) zwischen den zwei starren Abschnitten (33, 35).

17. Das Verfahren nach Anspruch 16, wobei der Schritt des Falten der Schaltungsplatte ein Falten der Schaltungsplatte enthält, so dass die starren Abschnitte der Schaltungsplatte vertikal gestapelt werden.

### Revendications

1. Capsule de détection in vivo endoscopique (10) comprenant:

- une carte de circuit qui comprend au moins deux sections rigides (33, 35) et une section flexible (32') reliant lesdits deux sections rigides (33, 35), et  
une ou plusieurs batteries (25) positionnées entre les deux sections rigides (33, 35).
2. Capsule selon la revendication 1, comprenant en plus l'un d'un capteur de pH, d'un capteur de température, d'un capteur d'image (24) et d'un capteur de pression. 5
  3. Capsule selon l'une des revendications 1 ou 2, comprenant en plus un émetteur (26). 10
  4. Capsule selon la revendication 1, comprenant en plus au moins un composant sélectionné à partir du groupe consistant à une source d'éclairage (23), un capteur (24), un processeur, un émetteur (26) ou une combinaison de ceux-ci. 15
  5. Capsule selon la revendication 4 dans laquelle au moins un composant est disposé sur au moins l'une desdites sections rigides de la carte de circuit. 20
  6. Capsule selon la revendication 5, dans laquelle ledit au moins composant est relié électriquement à travers un micro trou d'interconnexion dans la section rigide. 25
  7. Capsule selon la revendication 1, comprenant en plus un capteur (24) et un émetteur (26), dans laquelle le capteur (24) est disposé sur une première section rigide (33) de la carte de circuit et l'émetteur (26) est disposé sur une autre section rigide (31) de la carte de circuit. 30
  8. Capsule selon l'une des revendications 1 à 7, dans laquelle une pluralité de sections flexibles est pourvue et les sections rigides sont alternées avec les sections flexibles. 35
  9. Capsule selon la revendication 1, dans laquelle la carte de circuit est pliée de sorte que les sections rigides de la carte de circuit sont empilées verticalement. 40
  10. Capsule selon la revendication 1, dans laquelle les sections rigides sont reliées par des connecteurs verticaux. 45
  11. Capsule selon la revendication 10, dans laquelle les connecteurs verticaux sont des conducteurs électriques. 50
  12. Capsule selon la revendication 10 ou 11, dans laquelle les connecteurs verticaux sont des ressorts (56, 58). 55
  13. Capsule selon la revendication 12, dans laquelle les ressorts (56, 58) sont des ressorts coniques.
  14. Capsule selon l'une des revendications 1 à 13, dans laquelle la carte de circuit inclut du flexiglass.
  15. Dispositif à capsule selon l'une des revendications 1 à 14, l'une ou les deux desdites sections rigides (33, 35) incluant un contact de batterie.
  16. Procédé pour la fabrication d'une capsule in vivo comprenant les étapes de:
    - disposer au moins un capteur sur une section rigide d'une carte de circuit qui comprend au moins deux sections rigides (33, 35) et une section flexible (32') reliant lesdites deux sections rigides (33, 35), et
    - plier la carte de circuit dans un logement configuré pour une détection in vivo, incluant le positionnement d'une ou de plusieurs batteries (25) entre les deux sections rigides (33, 35).
  17. Procédé de la revendication 16, dans lequel l'étape de pliage de la carte de circuit inclut le pliage de la carte de circuit de sorte que les sections rigides de la carte de circuit sont empilées verticalement.

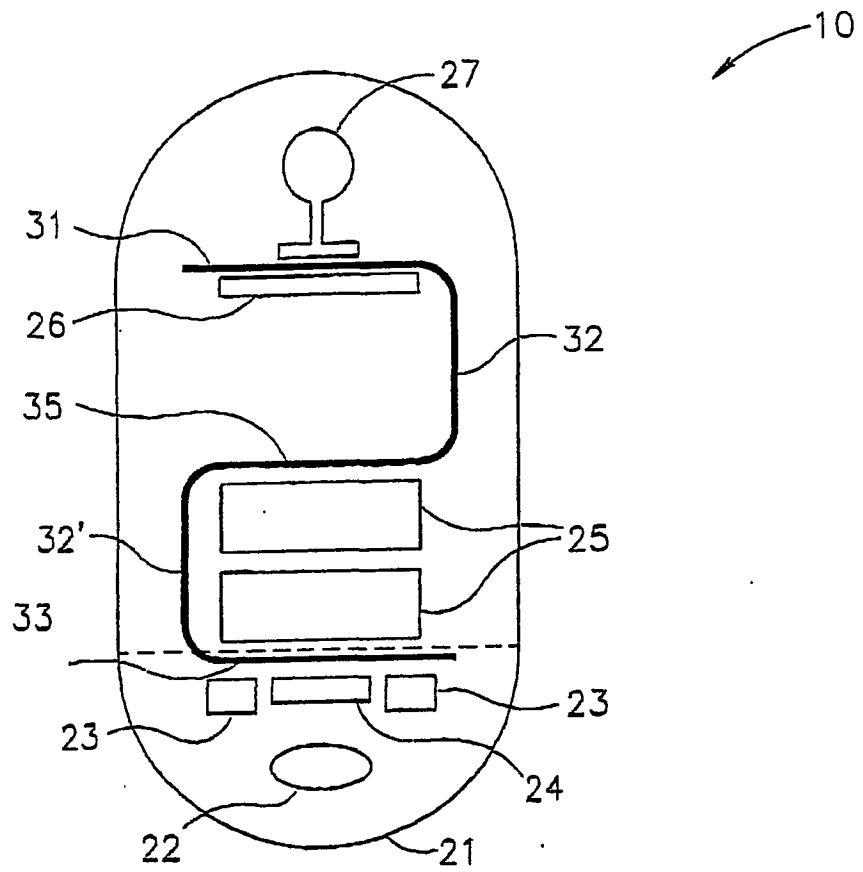

FIG. 1

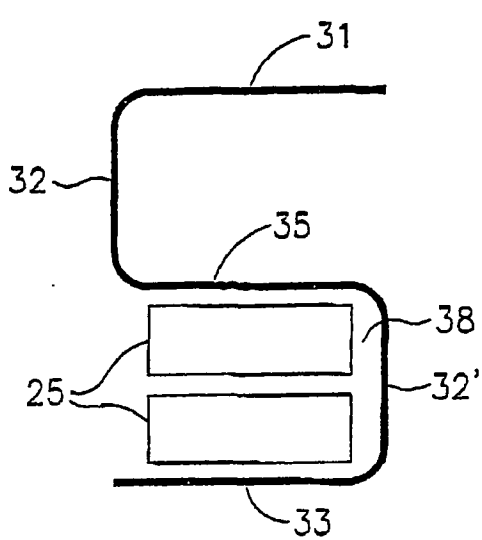

FIG. 2A

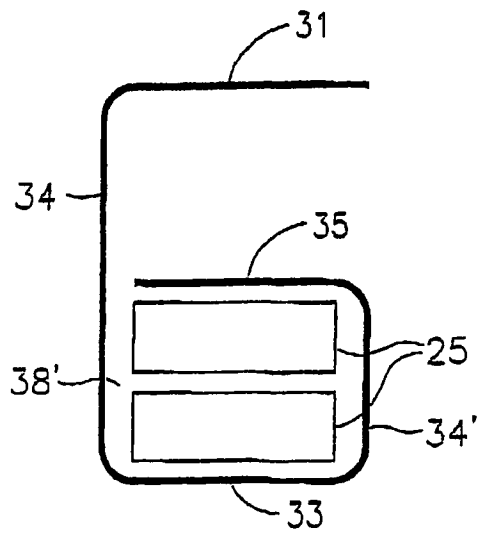

FIG. 2B

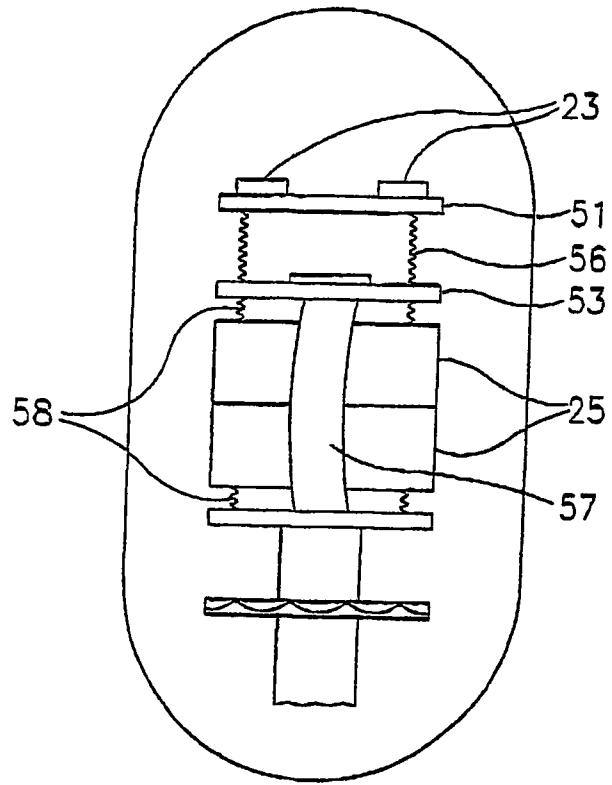

FIG.3

**REFERENCES CITED IN THE DESCRIPTION**

*This list of references cited by the applicant is for the reader's convenience only. It does not form part of the European patent document. Even though great care has been taken in compiling the references, errors or omissions cannot be excluded and the EPO disclaims all liability in this regard.*

**Patent documents cited in the description**

- US 3791377 A [0005]
- US 4803992 A [0006]
- EP 1104182 A1 [0007]
- WO 0165995 A [0012]
- US 5604531 A, Iddan [0012]

**Non-patent literature cited in the description**

- **GAVRIEL D. MERON.** The development of the swallowable video capsule (M2A). *Gastrointestinal endoscopy*, 2000, vol. 52 (6), 817-819 [0003]
- **MARK APPLEYARD et al.** A randomized trial comparing wireless capsule endoscopy with push enteroscopy for the detection of small-bowel lesions. *Gastroenterology*, 2000, vol. 119, 1431-1438 [0004]

专利名称(译)	可吞咽的体内传感胶囊，其具有具有刚性部分和柔性部分的电路板		
公开(公告)号	<a href="#">EP1418833B1</a>	公开(公告)日	2008-08-13
申请号	EP2002738602	申请日	2002-06-18
[标]申请(专利权)人(译)	基文影像公司		
申请(专利权)人(译)	基文影像有限公司.		
当前申请(专利权)人(译)	基文影像有限公司.		
[标]发明人	AVNI DOV		
发明人	AVNI, DOV		
IPC分类号	A61B5/07 A61B1/00 A61B5/00 H05K1/00 A61B5/01 A61B1/04 A61B1/05 H05K1/18		
CPC分类号	A61B5/0031 A61B1/041 H05K1/189 H05K3/3436 H05K2201/10151 Y02P70/613		
代理机构(译)	SIEGERT , GEORG		
优先权	60/298387 2001-06-18 US		
其他公开文献	EP1418833A4 EP1418833A2		
外部链接	<a href="#">Espacenet</a>		

摘要(译)

一种可吞咽的体内传感胶囊 ( 10 )，包括：电路板，包括多个刚性部分 ( 31,33,35; 51,53 )，所述刚性部分 ( 33,35 ) 中的至少两个通过柔性连接部分 ( 32,32' ) 和一个或多个电池 ( 25 ) 位于两个刚性部分之间，可吞咽的体内传感胶囊还包括设置在至少一个刚性部分 ( 33,51 ) 上的照明源 ( 23 ) 电路板。

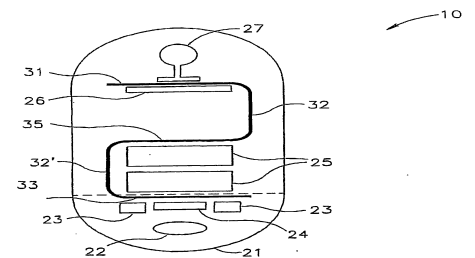

FIG. 1

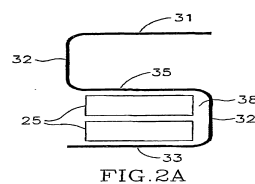

FIG. 2A

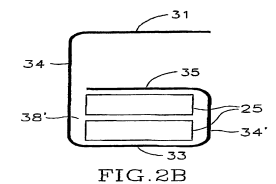

FIG. 2B