

(19)



Europäisches Patentamt
European Patent Office
Office européen des brevets



(11)

EP 1 289 409 B1

(12)

EUROPEAN PATENT SPECIFICATION

(45) Date of publication and mention
of the grant of the patent:
05.04.2006 Bulletin 2006/14

(21) Application number: **01934194.0**

(22) Date of filing: **01.06.2001**

(51) Int Cl.:
A61B 5/00 (2006.01)

(86) International application number:
PCT/GB2001/002450

(87) International publication number:
WO 2001/093754 (13.12.2001 Gazette 2001/50)

(54) **POPULATION MONITORING SYSTEM**

VORRICHTUNG ZUR ÜBERWACHUNG EINER POPULATION
SYSTEME DE SURVEILLANCE DE POPULATION

(84) Designated Contracting States:
**AT BE CH CY DE DK ES FI FR GB GR IE IT LI LU
MC NL PT SE TR**

(30) Priority: **06.06.2000 GB 0013610**

(43) Date of publication of application:
12.03.2003 Bulletin 2003/11

(73) Proprietor: **THE SECRETARY OF STATE FOR
DEFENCE
Salisbury
Wiltshire SP4 0JQ (GB)**

(72) Inventors:
• **MARTIN, Keith Llewellyn,
c/o DERA Porton Down
Salisbury,
Wiltshire SP4 0JQ (GB)**

- **COX, Christopher S.,
c/o DERA Porton Down
Salisbury,
Wiltshire SP4 0JQ (GB)**
- **BIGGINS, Peter, Douglas,
c/o DERA Porton Down
Salisbury,
Wiltshire SP4 0JQ (GB)**

(74) Representative: **Farnsworth, Alastair Graham et al
D/IPR Formalities Section
Poplar 2
MOD Abbey Wood No. 2218
Bristol, BS34 8JH (GB)**

(56) References cited:
EP-A- 0 976 360 DE-A- 19 848 229
US-A- 5 652 570

EP 1 289 409 B1

Note: Within nine months from the publication of the mention of the grant of the European patent, any person may give notice to the European Patent Office of opposition to the European patent granted. Notice of opposition shall be filed in a written reasoned statement. It shall not be deemed to have been filed until the opposition fee has been paid. (Art. 99(1) European Patent Convention).

Description

[0001] This invention relates to a system for monitoring a live population, with data from the population being transferred to a remote station for analysis.

[0002] There are various situations where there is a need for the monitoring over a period of time of the state of a live population (whether human, animal or plant) and the location of the population members. An example is where emergency service personnel are dealing with hazardous incidents. The monitoring is on the whole done by the personnel using radio or telephone communications to provide the necessary information to another human. The information provided can be analysed manually or from input to a computer, so that appropriate action can be triggered, for example in a medical emergency to provide appropriate help to the correct location. This system relies on a human initiating the communication in the first place, and may not provide accurate medical or location information. It is also difficult to correlate information from different sources to provide an overall picture of the incident, to enable hazards to be predicted.

[0003] US 5 652 570 discloses an interactive individual location and monitoring system for determining the condition and location status of an individual. The system includes a wrist watch, equipped with a sensor and transponder, and a pod unit including a transponder for onward transmission to a central monitoring system of data sensed by or input to the watch. The pod unit also transmits the location of the individual in response to an interrogation signal from the central monitoring system.

[0004] EP 0 976 360 discloses an individual monitoring system based on transmission of the location data by a mobile communication unit to a host unit when a predetermined condition is sensed. Information concerning the sensed condition, which may comprise an abnormal vital sign, is also transmitted to the host unit,

[0005] DE 198 48 229 discloses a system for on-line monitoring of a patient in which a portable medical data recording unit is coupled to a telephone switching circuit and a transmission/reception switching circuit of a mobile phone for a radio network. The coupling permits simultaneous recording of ECG data to memory and on-line transmission of the sensed data to an external receiving station. The unit also comprises a GPS switching circuit allowing the location of the wearer to be determined.

[0006] According to the present invention there is provided a system for monitoring a live population, comprising

- i) local data collection means operative to derive data relating to the physical condition of at two or more population members,
- ii) a local processor for correlating and storing the physical condition data of said two or more population members relative to time and
- iii) means for transferring the stored data of said two or more population members from the local proces-

sor to a remote data collection means,

which remote data collection means is operative to access information relating to the location of said at least one population member relative to time and in which the remote data collection means comprises a main processor operative to analyse the physical condition and the location data of said two or more population members and predict and/or signal a disease event within the population or an environmental condition hazardous to the population.

[0007] As the physical condition data and location data are correlated with time, these data can be provided accurately to the remote data collection means. The data can then be analysed for unusual events, if necessary in conjunction with data from other sources, to predict and signal the unusual events, enabling appropriate action to be taken. The monitoring system therefore performs more efficiently.

[0008] The live population may be a population of humans, animals or plants. The data relating to physical condition picks up abnormal physical symptoms, due to disease as such, injury or other factors such as environmental conditions. Analysis of this data can then be used to identify unusual events, in terms of disease, or environmental conditions.

[0009] The local data collection means and local processor are preferably incorporated in a unit. A single unit may derive data relating to physical condition from more than one population member, but it is preferred that each population member has their own unit. This enables easy monitoring of each population member separately.

[0010] The local data collection means then preferably comprises a sensor attached to the population member, and controlled by the local processor. The processor may operate the sensor continuously or intermittently. This is particularly useful where the population consists of animals or plants, but may also be useful for humans. As operation of the unit is automatic, there is no room for human error.

[0011] Alternatively, the local data collection means may comprise a manually-operable device, into which data relating to physical condition is input. Clearly, this can only be operated by humans, but is useful for deriving data from more than one population member.

[0012] Conveniently the means for transferring the stored data comprises telecommunication means, for sending radio signals or the like. A telecommunication means is preferably associated with each local data collection means. It is preferably incorporated in a unit with the local data collection means and the local processor, and is controlled by the local processor.

[0013] The operation of the local processor is preferably programmable. The telecommunication means may be operative to receive data to alter the programming of the local processor.

[0014] The unit preferably contains a power source such as batteries, operated under the control of the local

processor.

[0015] Preferably the unit includes a location means operative to derive data relating to the location of the population member, and the local processor then correlates and stores the physical condition data and the location data relative to time. This provides particularly accurate physical condition and location data.

[0016] The local processor then controls operation of the location means as well, so that it is operated continuously or intermittently.

[0017] Alternatively the location means may be separate from the unit. The location means may transmit the location data to the remote data collection means. The unit may transmit the physical condition data to the remote data collection means via the location means. The location means may then correlate the physical condition and location data relative to time.

[0018] The remote data collection means may simply comprise a central computer station for receiving, storing and analysing the data. Alternatively it may comprise a central station and a number of intermediate stations which receive the data from one or more units, and relay it to the central station for storage and analysis. With this arrangement, the location means may be at the intermediate station, which correlates the location and physical condition data relative to time, and relays it to the central station. The data is preferably stored at the central station in a computer database.

[0019] The sensor for a human or animal may derive data relating to several states of the body, including pulse rate, temperature, oxyhaemoglobin, carboxyhaemoglobin and cytochrome oxidase. Monitoring is preferably by a non-invasive sensor. This may be of a near infra-red spectroscopy (NIRS) type or any other suitable type. Sensors for plants may derive data relating to temperature, water content and the like.

[0020] The location data is preferably derived from a global positioning satellite system.

[0021] Embodiments of the invention are illustrated, by way of example only, in the accompanying drawings, in which:-

Figure 1 is a semi-diagrammatic illustration of a population monitoring system according to the invention;

Figure 2 is a diagrammatic illustration of a unit used in Figure 1;

Figure 3 is similar to Figure 2, but shows a modified unit; and

Figure 4 is a semi-diagrammatic illustration of a modified monitoring system.

[0022] The population monitoring system of Figure 1 has a unit 1 which derives data about the state of a population member 2 (in this case a human body), data being transferred from the unit 1 to a remote station 3 for anal-

ysis.

[0023] The unit 1 is shown in more detail in Figure 2. It comprises a sensor 4 adapted to be attached to the body 2 to derive data relating to the physical condition of the body 2, a location means 5 which derives data relating to the location of the body 2, a local processor 6 for correlating and storing the physical data and location data relative to time, and telecommunication means 7 for transmitting the stored data to the remote station 3.

[0024] The sensor 4 is a non-invasive sensor of the near infra-red spectroscopy (NIRS) type. It has two sensor pads 8 adapted to be attached to the body 2 at spaced locations, such as the head and the arm. The sensor pads measure oxygen levels in the body 2, using near infra-red spectroscopy to monitor the levels of chromophores, whose absorbance is oxygen-dependent. Background interference from other tissues is compensated for by measuring changes in absorbance. The use of multiple wavelengths of light allows monitoring of changes in oxyhaemoglobin, carboxyhaemoglobin and cytochrome oxidase, which are all chemical states of the body relating to oxygenation levels and thus indicate the medical condition of the body 2. The sensor 4 also measures temperature and pulse data. The sensor pads 8 are non-invasively attached to the body 2 by detachable means such as tape or a band and by wires to the main part of the unit. The main part of the unit 1 is attached to the body 2 or the wearer's clothing. It can be made small and lightweight.

[0025] The main part of the unit 1 also houses the location means 5, comprising a global positioning monitor 9 which receives spatial co-ordinates from a satellite 10, as well as the time.

[0026] The data from the sensor 4 and the location means 5 is transmitted to the local processor 6, which correlates and stores it in relation to time, in a suitable electronic memory. The processor 6 is a programmable microprocessor unit adapted to operate the sensor and the location means as required. Thus, the sensor and location means may be operated continuously or intermittently. The unit 1 also includes a power source in the form of a battery 11, and the local processor 6 is also programmed to act as a power management system. Further the local processor 6 operates the telecommunication means 7 periodically to send the stored data to the remote station 3. The telecommunication means 7 sends the data by a radio signal, either directly or using a satellite 12 as a communications channel. The data could instead be transferred by telephone (terrestrial or satellite) or cable, or even manually.

[0027] Figure 3 shows a modified unit 1' in which the sensor 4 is omitted, and the data relating to physical condition is instead derived by manual input by a human operator. Thus, the unit 1' has an input terminal 13 instead of the sensor 4 and pads 8. The terminal 13 has a screen 14 and keys 15. The processor 6 stores a number of physical conditions, one or more of which are chosen by the operator to input to the processor 6. Thus unit 1'

may also be used to derive data for more than one population member. The details of the individual population members are also held by the processor 6, so that the data is related to the individuals. The construction and operation of the unit 1 is otherwise the same as that of the unit 1 of Figure 2.

[0028] The remote station 3 comprises a data collection computer 16 including a database in which the data is stored for analysis. The computer includes a main processor for analysing the physical condition and location data for unusual events and providing a signal on the occurrence of an unusual event. The computer 16 may also have access to other, collateral, data, to assist in the identification of unusual events. The other data may be meteorological, geographic, pollution, medical or demographic databases.

[0029] The analysis of unusual events is based on the data from the units 1 or 1' and the collateral databases, chosen as required according to the expected events. The analysis uses a set of rules describing the signature of an event as a departure from a normal background level of one or more parameters. The rules assign relative significance values to the events, to enable their significance to be evaluated singly and in combination, particularly where they arise from different databases. The rules assign an overall significance value, as a probability that an unusual event has occurred. The rules may vary according to the parameters used.

[0030] An example which is useful in practice is the analysis of disease events from medical data, time, location and meteorological data. One such analysis of a particular infectious disease has been carried out retrospectively. The rules looked at the occurrence of the disease as a function of time, location (by postal area in UK) and the meteorological record.

[0031] A first rule looked at the number of cases of the disease in relation to time and meteorological conditions, to predict the number of cases which would occur in a given future time period. The rule was modified if the predicted number of cases varied significantly from the actual number.

[0032] A second rule looked at the location of the cases, that is the spatial distribution in the postal areas. An infectious disease is expected to form clusters of cases, and the degree of clustering can be used to test the randomness of the spatial distribution to determine a departure from the expected distribution.

[0033] A third rule looked for a correlation between the spatial distribution of the cases and the prevailing wind, at a given time. The rule was modified according to any correlation.

[0034] Several instances of unusual events (for example, the disease becoming epidemic) were detected by the three rules.

[0035] The monitoring system has also been used with the unit 1' of Figure 3, to test the analysis in real time, based on manual input of physical condition, location data and meteorological data, to detect unusual events in

environmental conditions, as at a hazardous incident. Here an unusual event may occur when the physical condition of several population members in a given case changes, and danger can be predicted. This enables evasive action to be taken by the individuals concerned.

[0036] Thus, the monitoring system can be used for populations, to signal unusual events. While it has been described in terms of monitoring a population of humans it would also be used to monitor populations of animals or even plants. When monitoring plants, data relating to location will be input to, or otherwise available to the central data collection computer 16 as global positioning will not be a requirement.

[0037] Figure 4 shows a modified monitoring system particularly suitable for monitoring groups of population members in a given area, and corresponding reference numerals have been applied to corresponding parts. In Figure 4, the location means 5 are provided not on the units 1, but at an intermediate or base station 17. The unit 1 therefore derives only physical conditions data, which the processor 6 correlates and stores relative to time. The processor 6 in this case provides the time information. The intermediate station serves to derive data on the location from the global positioning system. It has communication means 18 for receiving the physical condition data from the units 1, and relaying this, together with the location data, to the central data collection computer 16 for analysis. The physical condition and location data may be correlated by the intermediate station or the central computer 16. The communication means 18 preferably relays the data by a radio signal, but the data could be transferred by any suitable means.

35 Claims

1. A system for monitoring the state of a live population, comprising
 - i) local data collection means operative to derive data relating to the physical condition of two or more population members
 - ii) a local processor for correlating and storing the physical condition data of said two or more population members relative to time and
 - iii) means for transferring the stored data of said two or more population members from the local processor to a remote data collection means,

which remote data collection means is operative to access information relating to the location of said two or more population members relative to time and in which the remote data collection means comprises a main processor operative to analyse the physical condition and the location data of said two or more population members and predict and/or signal a disease event within the population or an environmental condition hazardous to the population.

2. A system according to Claim 1, in which the remote data collection means has access to collateral data comprising meteorological, geographic, pollution, medical or demographic databases.
3. A system according to Claim 1 or Claim 2, in which the main processor is configured to analyse said physical condition data and location data according to a set of rules which assign a relative significance to each departure from the normal background level in one or more parameters and an overall significance value as a probability that an event or condition has occurred.
4. A system according to any preceding Claim, in which local data collection means and local processor are provided together in a single unit.
5. A system according to Claim 4, in which the local data collection means comprise a manually-operable device for input of physical condition data from said two or more population members.
6. A system according to Claim 4, in which said two or more population members are provided with their own unit,
7. A system according to Claim 6, in which the local data collection means of each unit comprises a sensor attached to each population member and controlled by the local processor.
8. A system according to Claim 7, in which the sensor comprises a non-invasive sensor which is adapted to derive data relating to oxygen levels in a human or animal body.
9. A system according to any preceding Claim, in which the means for transferring the stored data comprise telecommunication means associated with the local data collection means.
10. A system according to Claim 9, in which telecommunication means is incorporated into each unit with the local data collection means for control by the local processor.
11. A system according to Claim 9 or Claim 10, in which the telecommunication means is adapted to send the stored data by a radio signal.
12. A system according to any preceding Claim, in which the local processor is programmable and, optionally, operative to receive data to alter its programming.
13. A system according to any of Claims 4 to 12, in which each unit includes location means operative to derive data relating to the location of said two or more population members and the local processor is adapted to correlate and store the physical condition data and location data relative to time.
14. A system according to Claim 13, in which the local processor is adapted to control the operation of the location means.
15. A system according to any of Claims 4 to 12, comprising a location means operative to derive data relating to the locations of said two or more population members which is separate from the local data collection means.
16. A system according to Claim 15, in which the location means is adapted to transmit the location data to the remote data collection means.
17. A system according to Claim 15 or Claim 16, in which the means for transferring the stored data is adapted to transmit it to the remote data collection means via the location means
18. A system according to any preceding Claim, in which the remote data collection means comprise a central computer station and, optionally, a number of intermediate relay stations which are adapted to relay the data from each unit to the central station.
19. A system according to Claim 18 when dependent on Claim 14, in which each intermediate station includes a location means which is adapted to transmit location data to the central station.

Revendications

1. Système pour surveiller l'état d'une population vivante, comprenant:
- i) un moyen de collecte de données local opérationnel pour dériver des données relatives à la condition physique de deux membres de la population ou plus,
 - ii) un processeur local pour corrélérer et stocker les données de condition physique desdits deux membres de la population ou plus relativement au temps et
 - iii) un moyen pour transférer les données stockées desdits deux membres de la population ou plus du processeur local à un moyen de collecte de données distant,
- lequel moyen de collecte de données distant est opérationnel pour accéder à des informations relatives à la localisation desdits deux membres de la population ou plus relativement au temps et dans lequel le moyen de collecte de données distant comprend

- un processeur principal opérationnel pour analyser les données de condition physique et de localisation desdits deux membres de la population ou plus et prédire et/ou signaler un événement de maladie à l'intérieur de la population ou une condition environnementale dangereuse pour la population.
2. Système selon la revendication 1, dans lequel le moyen de collecte de données distant a accès à des données collatérales comprenant des bases de données météorologiques, géographiques, de pollution, médicales ou démographiques. 5
 3. Système selon la revendication 1 ou la revendication 2, dans lequel le processeur principal est configuré pour analyser lesdites données de condition physique et données de localisation selon un ensemble de règles qui attribuent une signification relative à chaque écart du niveau de fond normal dans un ou plusieurs paramètres et une valeur de signification globale comme une probabilité qu'un événement ou une condition s'est produit. 10
 4. Système selon l'une quelconque des revendications précédentes, dans lequel le moyen de collecte de données local et le processeur local sont pourvus ensemble dans une seule unité. 15
 5. Système selon la revendication 4, dans lequel le moyen de collecte de données local comprend un dispositif utilisable manuellement pour l'entrée de données de condition physique provenant desdits deux membres de la population ou plus. 20
 6. Système selon la revendication 4, dans lequel lesdits deux membres de la population ou plus sont pourvus de leur propre unité. 25
 7. Système selon la revendication 6, dans lequel le moyen de collecte de données local de chaque unité comprend un capteur fixé à chaque membre de la population et contrôlé par le processeur local. 30
 8. Système selon la revendication 7, dans lequel le capteur comprend un capteur non invasif qui est adapté pour dériver des données relatives aux niveaux d'oxygène dans un corps humain ou animal. 35
 9. Système selon l'une quelconque des revendications précédentes, dans lequel le moyen pour transférer les données stockées comprend un moyen de télécommunication associé au moyen de collecte de données local. 40
 10. Système selon la revendication 9, dans lequel le moyen de télécommunication est incorporé dans chaque unité avec le moyen de collecte de données local pour le contrôle par le processeur local. 45
 11. Système selon la revendication 9 ou la revendication 10, dans lequel le moyen de télécommunication est adapté pour envoyer les données stockées par un signal radio. 50
 12. Système selon l'une quelconque des revendications précédentes, dans lequel le processeur local est programmable et, facultativement, opérationnel pour recevoir des données pour modifier sa programmation. 55
 13. Système selon l'une quelconque des revendications 4 à 12, dans lequel chaque unité comprend un moyen de localisation opérationnel pour dériver des données relatives à la localisation desdits deux membres de la population ou plus et le processeur local est adapté pour corréler et stocker les données de condition physique et les données de localisation relativement au temps.
 14. Système selon la revendication 13, dans lequel le processeur local est adapté pour contrôler le fonctionnement du moyen de localisation.
 15. Système selon l'une quelconque des revendications 4 à 12, comprenant un moyen de localisation opérationnel pour dériver des données relatives aux localisations desdits deux membres de la population ou plus qui est séparé du moyen de collecte de données local.
 16. Système selon la revendication 15, dans lequel le moyen de localisation est adapté pour transmettre les données de localisation au moyen de collecte de données distant.
 17. Système selon la revendication 15 ou la revendication 16, dans lequel le moyen pour transférer les données stockées est adapté pour les transmettre au moyen de collecte de données distant via le moyen de localisation.
 18. Système selon l'une quelconque des revendications précédentes, dans lequel le moyen de collecte de données distant comprend une station informatique centrale et, facultativement, un certain nombre de stations relais intermédiaires qui sont adaptées pour relayer les données de chaque unité à la station centrale.
 19. Système selon la revendication 18 lorsque dépendante de la revendication 14, dans lequel chaque station intermédiaire comprend un moyen de localisation qui est adapté pour transmettre des données de localisation à la station centrale.

Patentansprüche

1. System zur Überwachung des Zustands einer lebenden Population, das umfaßt:
- i) eine lokale Datenerfassungseinrichtung, die zur Gewinnung von Daten bezüglich des physischen Zustands von zwei oder mehreren Populationsmitgliedern betrieben wird,
 - ii) einen lokalen Prozessor zur Korrelation und Speicherung von Daten über den physischen Zustand der zwei oder mehreren Populationsmitglieder, bezogen auf die Zeit, und
 - iii) eine Einrichtung zur Übertragung der gespeicherten Daten über die zwei oder mehreren Populationsmitglieder vom lokalen Prozessor zu einer entfernten Datenerfassungseinrichtung,
- wobei die entfernte Datenerfassungseinrichtung so arbeitet, daß sie auf Informationen in Bezug auf den Aufenthaltsort der zwei oder mehreren Populationsmitglieder, bezogen auf die Zeit, zugreift, und die entfernte Datenerfassungseinrichtung einen Hauptprozessor enthält, der zur Analyse der Daten über den physischen Zustand und den Aufenthaltsort der zwei oder mehreren Populationsmitglieder und zur Vorhersage und/oder Mitteilung über ein Krankheitsereignis in der Population oder einer Umweltbedingung betrieben wird, die für die Population gefährlich ist.
2. System nach Anspruch 1, bei dem die entfernte Datenerfassungseinrichtung Zugriff auf Kollateraldaten hat, die meteorologische, geographische, Umweltverschmutzungs-, medizinische oder demographische Datenbanken umfassen.
3. System nach Anspruch 1 oder 2, bei dem der Hauptprozessor so konfiguriert ist, daß er die Daten über den physischen Zustand und den Aufenthaltsort gemäß einem Satz von Regeln analysiert, die jeder Abweichung vom normalen Hintergrundpegel in einem oder in mehreren Parametern eine relative Signifikanz zuordnen und einen Gesamtsignifikanzwert als Wahrscheinlichkeit zuordnen, daß ein Ereignis stattgefunden hat oder ein Zustand eingetreten ist.
4. System nach einem der vorhergehenden Ansprüche, bei dem die lokale Datenerfassungseinrichtung und der lokale Prozessor gemeinsam in einer einzigen Einheit untergebracht sind.
5. System nach Anspruch 4, bei dem die lokale Datenerfassungseinrichtung eine manuell betätigbare Vorrichtung zur Eingabe von Daten über den physischen Zustand der zwei oder mehreren Populationsmitglieder umfaßt.
6. System nach Anspruch 4, bei dem die zwei oder mehreren Populationsmitglieder mit einer eigenen Einheit ausgerüstet sind.
7. System nach Anspruch 6, bei dem die lokale Datenerfassungseinrichtung jeder Einheit einen Sensor enthält, der an jedem Populationsmitglied befestigt ist und vom lokalen Prozessor gesteuert wird.
8. System nach Anspruch 7, bei dem der Sensor ein nichtinvasiver Sensor ist, der so ausgebildet ist, daß er Daten erfaßt, die sich auf den Sauerstoffgehalt in einem menschlichen oder tierischen Körper beziehen.
9. System nach einem der vorhergehenden Ansprüche, bei dem die Einrichtung zur Übertragung der gespeicherten Daten eine Telekommunikationseinrichtung enthält, die an die lokale Datenerfassungseinrichtung angeschlossen ist.
10. System nach Anspruch 9, bei dem die Telekommunikationseinrichtung mit der lokalen Datenerfassungseinrichtung zur Steuerung durch den lokalen Prozessor in jede Einheit eingebaut ist.
11. System nach Anspruch 9 oder 10, bei dem die Telekommunikationseinrichtung so ausgebildet ist, daß sie die gespeicherten Daten durch ein Funksignal sendet.
12. System nach einem der vorhergehenden Ansprüche, bei dem der lokale Prozessor programmierbar ist und wahlweise so betrieben werden kann, daß er Daten empfängt, die seine Programmierung ändern.
13. System nach einem der Ansprüche 4 bis 12, bei dem jede Einheit eine Lokalisierungseinrichtung enthält, die zur Gewinnung von Daten betrieben wird, die sich auf den Aufenthaltsort der zwei oder mehreren Populationsmitglieder beziehen, und bei dem der lokale Prozessor so ausgebildet ist, daß er die Daten über den physischen Zustand und den Aufenthaltsort zeitbezogen korreliert und speichert.
14. System nach Anspruch 13, bei dem der lokale Prozessor so ausgebildet ist, daß er den Betrieb der Lokalisierungseinrichtung steuert.
15. System nach einem der Ansprüche 4 bis 12, das eine Lokalisierungseinrichtung enthält, die so arbeitet, daß sie Daten erfaßt, die sich auf die Aufenthaltsorte der zwei oder mehreren Populationsmitglieder beziehen und die von der lokalen Datenerfassungseinrichtung getrennt ist.
16. System nach Anspruch 15, bei dem die Lokalisierungseinrichtung so ausgebildet ist, daß sie die Da-

ten des Aufenthaltsorts zur entfernten Datenerfassungseinrichtung überträgt.

17. System nach Anspruch 15 oder 16, bei dem die Einrichtung zur Übertragung der gespeicherten Daten so ausgebildet ist, daß sie die gespeicherten Daten über die Lokalisierungseinrichtung zur entfernten Datenerfassungseinrichtung überträgt. 5
18. System nach einem der vorhergehenden Ansprüche, bei dem die entfernte Datenerfassungseinrichtung eine zentrale Computerstation und, optional, eine Reihe von Zwischenrelais-Stationen umfaßt, die so ausgebildet sind, daß sie die Daten von jeder Einheit zur zentralen Computerstation senden. 10 15
19. System nach Anspruch 18, wenn von Anspruch 14 abhängig, bei dem jede Zwischenstation eine Lokalisierungseinheit enthält, die so ausgebildet ist, daß sie die Daten über den Aufenthaltsort zur zentralen Station überträgt. 20

25

30

35

40

45

50

55

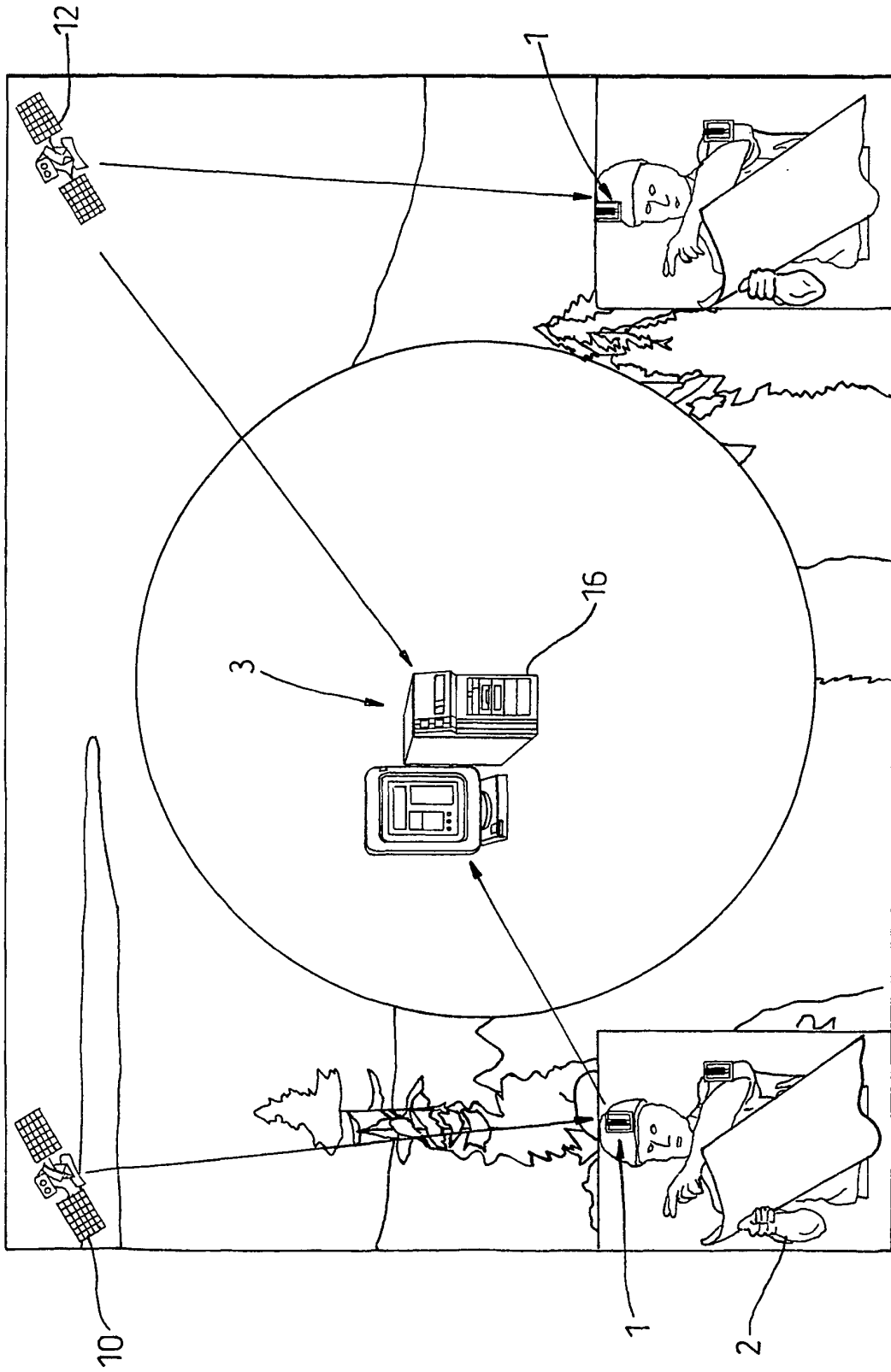

Fig. 1

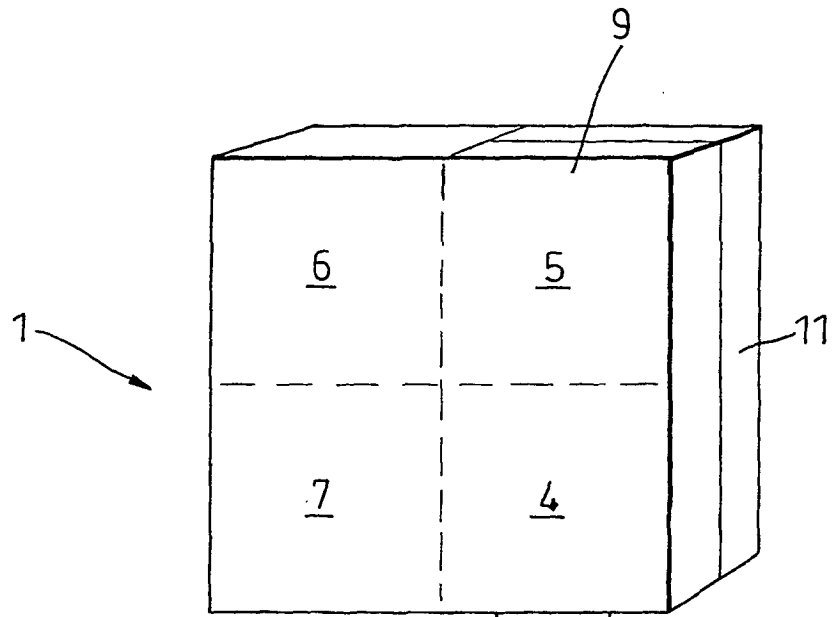

Fig. 2

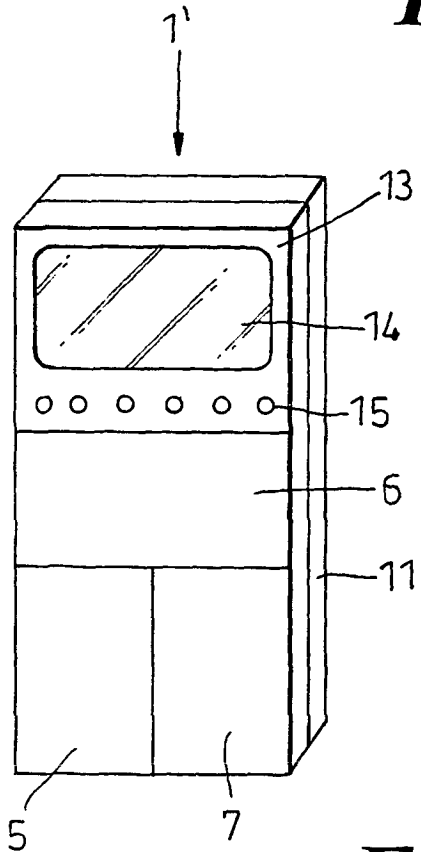
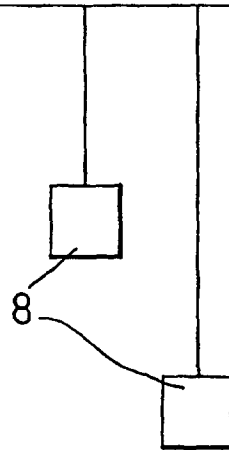

Fig. 3



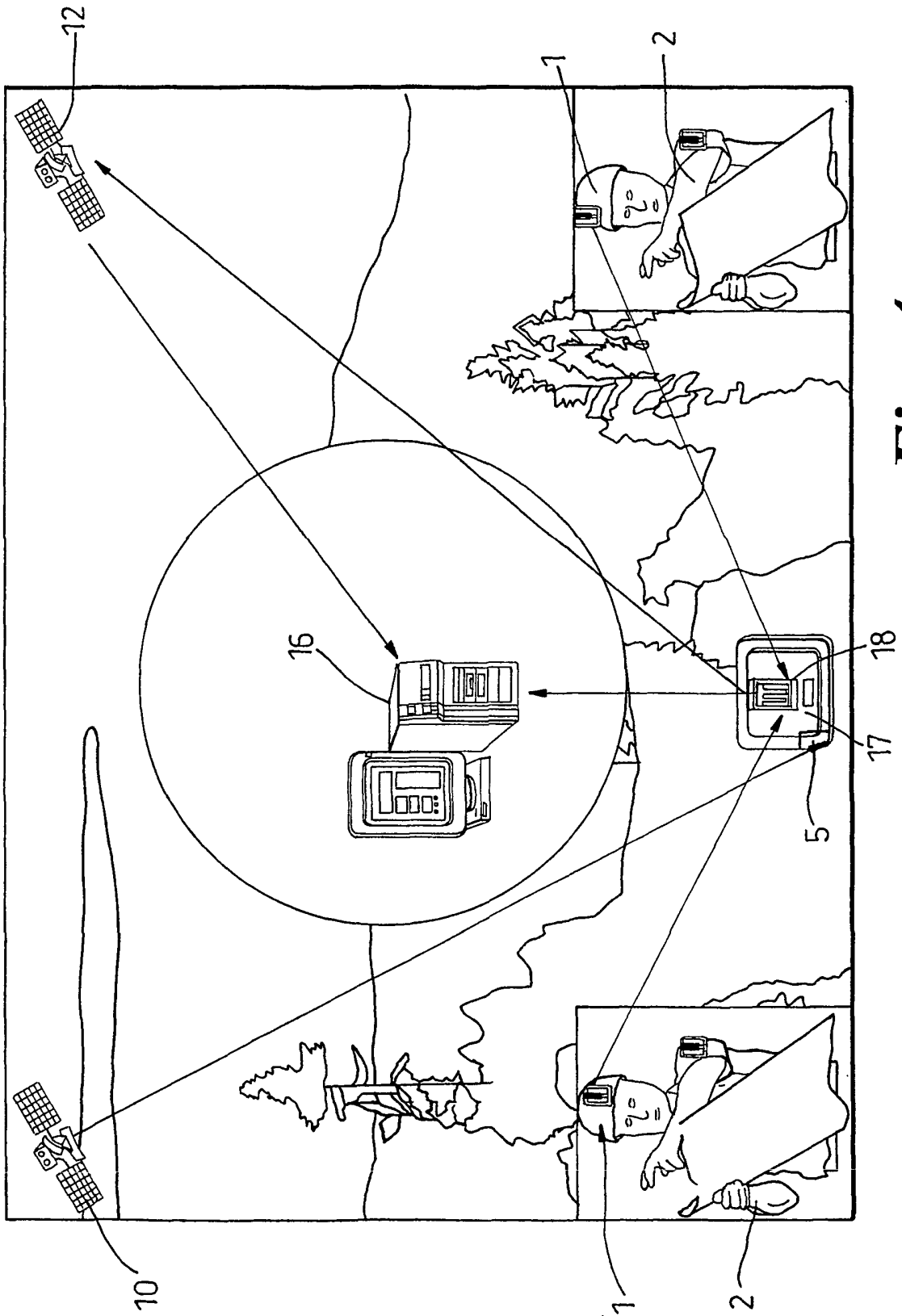

Fig. 4

专利名称(译)	人口监测系统		
公开(公告)号	EP1289409B1	公开(公告)日	2006-04-05
申请号	EP2001934194	申请日	2001-06-01
[标]申请(专利权)人(译)	英国国防部		
申请(专利权)人(译)	状态国防部长		
当前申请(专利权)人(译)	状态国防部长		
发明人	MARTIN, KEITH LLEWELLYN, C/O DERA PORTON DOWN COX, CHRISTOPHER S., C/O DERA PORTON DOWN BIGGINS, PETER, DOUGLAS, C/O DERA PORTON DOWN		
IPC分类号	A61B5/00		
CPC分类号	A61B5/1112 A61B5/002 A61B5/0022 A61B5/6814 A61B2560/0242 A61B2560/0462 G16H50/80		
优先权	2000013610 2000-06-06 GB		
其他公开文献	EP1289409A1		
外部链接	Espacenet		

摘要(译)

用于监视活人口的系统使用单元 (1) 作为本地数据收集装置来导出关于人口成员 (2) 的身体状况的数据。单元 (1) 具有用于关联和存储相对于时间的物理条件数据的本地处理器 (6)，以及用于将存储的数据从本地处理器 (6) 传送到远程数据收集装置 (3) 的装置 (7)。。远程数据收集装置还接收与人口成员 (2) 相对于时间的位置有关的数据，并分析异常事件的物理状况和位置数据，提供关于异常事件发生的信号。物理条件可以从传感器 (4) 导出，传感器 (4) 是用于测量脉冲速率，温度和氧气水平的非侵入式传感器。位置数据由结合在单元 (1) 中的定位装置 (5) 提供。

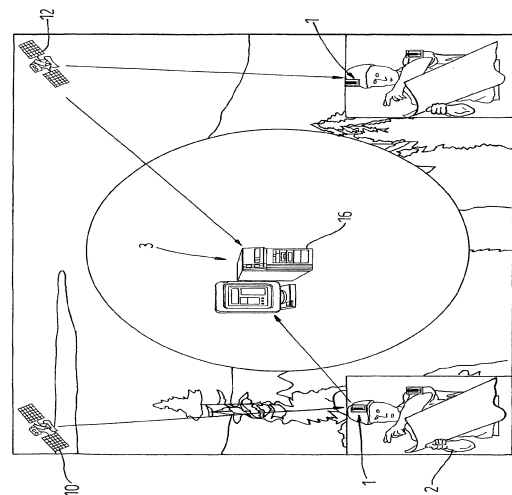

Fig. 1