



(51) International Patent Classification:

A61B 1/00 (2006.01) A61B 5/00 (2006.01)
A61B 3/00 (2006.01) A61B 1/04 (2006.01)

(21) International Application Number:

PCT/IB2012/050563

(22) International Filing Date:

8 February 2012 (08.02.2012)

(25) Filing Language:

English

(26) Publication Language:

English

(30) Priority Data:

1102209.2 9 February 2011 (09.02.2011) GB

(71) Applicants (for all designated States except US): **TEL HASHOMER MEDICAL RESEARCH INFRA-STRUCTURE AND SERVICES LTD.** [IL/IL]; The Chaim Sheba Medical Center, Tel Hashomer, 52621 Ramat Gan (IL). **RAMOT AT TEL AVIV UNIVERSITY LTD.** [IL/IL]; P.O. Box 39296, 61392 Tel Aviv (IL).

(72) Inventors; and

(75) Inventors/Applicants (for US only): **KOSTENICH, Genady** [IL/IL]; Emek Dotan 22, 52621 Ramat Gan (IL). **ORENSTEIN, Arie** [IL/IL]; Moyal 14, 69351 Tel Aviv (IL). **BELKIN, Michael** [IL/IL]; Alonim 4, 54044 Givat Shmuel (IL).

(74) Agent: **GUR, Erez**; Pob 1372, Weizman Street, 44113 Kfar Saba (IL).

(81) Designated States (unless otherwise indicated, for every kind of national protection available): AE, AG, AL, AM, AO, AT, AU, AZ, BA, BB, BG, BH, BR, BW, BY, BZ, CA, CH, CL, CN, CO, CR, CU, CZ, DE, DK, DM, DO, DZ, EC, EE, EG, ES, FI, GB, GD, GE, GH, GM, GT, HN, HR, HU, ID, IL, IN, IS, JP, KE, KG, KM, KN, KP, KR, KZ, LA, LC, LK, LR, LS, LT, LU, LY, MA, MD, ME, MG, MK, MN, MW, MX, MY, MZ, NA, NG, NI, NO, NZ, OM, PE, PG, PH, PL, PT, QA, RO, RS, RU, RW, SC, SD, SE, SG, SK, SL, SM, ST, SV, SY, TH, TJ, TM, TN, TR, TT, TZ, UA, UG, US, UZ, VC, VN, ZA, ZM, ZW.

(84) Designated States (unless otherwise indicated, for every kind of regional protection available): ARIPO (BW, GH, GM, KE, LR, LS, MW, MZ, NA, RW, SD, SL, SZ, TZ, UG, ZM, ZW), Eurasian (AM, AZ, BY, KG, KZ, MD, RU, TJ, TM), European (AL, AT, BE, BG, CH, CY, CZ, DE, DK, EE, ES, FI, FR, GB, GR, HR, HU, IE, IS, IT, LT, LU, LV, MC, MK, MT, NL, NO, PL, PT, RO, RS, SE, SI, SK, SM, TR), OAPI (BF, BJ, CF, CG, CI, CM, GA, GN, GQ, GW, ML, MR, NE, SN, TD, TG).

Published:

— with international search report (Art. 21(3))

(54) Title: METHODS AND DEVICES SUITABLE FOR IMAGING BLOOD-CONTAINING TISSUE

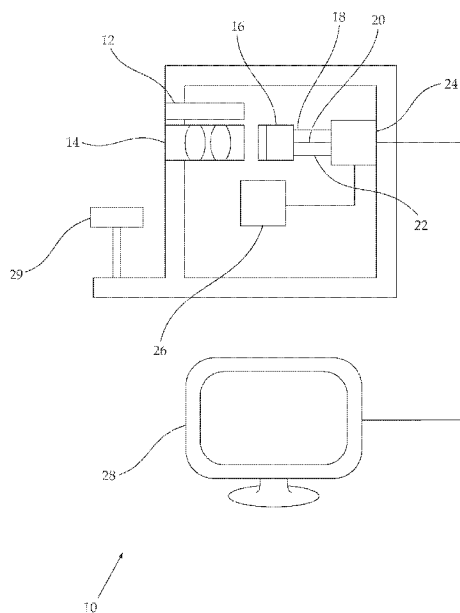

FIG. 3

(57) Abstract: Disclosed are methods and devices useful for imaging blood-containing tissue, for example for angiography, especially retinal angiography, whereby an image is generated by dividing pixels of an image acquired at some wavelength range by corresponding pixels of an image acquired at a different wavelength range. In some embodiments, a first wavelength range includes predominantly light having wavelengths between about 400 nm and about 620 nm and a second wavelength range includes predominantly light having wavelengths between about 620 nm and about 800 nm.

METHODS AND DEVICES SUITABLE FOR IMAGING BLOOD-CONTAINING
TISSUE

RELATED APPLICATION

The present application gains priority from UK Patent Application GB 1102209.2 filed 9 February 2011.

5

FIELD AND BACKGROUND OF THE INVENTION

The invention, in some embodiments, relates to the field of medical imaging, and more particularly but not exclusively, to methods and devices suitable for imaging blood-containing tissue, for example for angiography, especially retinal angiography.

10

Angiography is a technique for the *in vivo* imaging of blood vessels.

In some instances, angiography is performed by administering a radio-opaque contrast agent in the blood vessels of a living subject and then acquiring an image of the blood vessels using an X-ray imaging modality. Such methods are useful, for example, to acquire a 3-dimensional representation of cerebral blood vessels.

15

To avoid the use of an X-ray imaging modality, it is known to acquire a visible light image of shallow blood vessels in a bodily surface, for example, in the retina or mucosa such as the gastrointestinal luminal walls, with the use of fluorescence angiography. A fluorescent agent (e.g., sodium fluorescein or indocyanine green) is administered into the blood vessels of a subject. The surface to be imaged is illuminated with a fluorescence-exciting wavelength (e.g., 490 nm for sodium fluorescein, 800 nm for indocyanine green) and a camera used to acquire an image from the light emitted by the fluorescent agent (e.g., 530 nm for sodium fluorescein, 830 nm for indocyanine green).

20

It is also known to perform optical angiography, the use a suitable camera to acquire a visible-light color image of blood vessels, thus avoiding the complexity, time and potential health hazards associated with the administration of a fluorescent agent.

25

Visible-light color images often have insufficient contrast to clearly discern smaller blood vessels. It has been found that "red-free" images (e.g., images acquired where the camera lens is functionally associated with a green filter to prevent red light from being gathered) have greater contrast than color images.

30

In many fields, for example in the field of retinal angiography, it would be useful to have improved performance for example, increased contrast and/or greater spatial resolution. Such improved performance may allow gathering information useful in screening or diagnosing conditions such as cancer-related angiogenesis, diabetic retinopathy, age-related

macular degeneration and cardiovascular and brain diseases that have been shown to be related to the morphology of the retinal microvasculature.

Some may consider US patents 6,083,158; 6,104,939; 6,276,798; 6,556,853 as well as US patent application 2007/0253033 and as providing background to some embodiments of the teachings herein.

SUMMARY OF THE INVENTION

Some embodiments of the invention relate to methods and devices suitable for imaging blood-containing tissue, for example for performing angiography, that in some embodiments have advantages over known imaging methods and devices.

Some embodiments of the methods and devices described herein an image is generated by dividing pixels of an image acquired at some wavelength range by corresponding pixels of an image acquired at a different wavelength range. In some embodiments, a first wavelength range includes predominantly light having wavelengths between about 400 nm and about 620 nm and a second wavelength range includes predominantly light having wavelengths between about 620 nm and about 800 nm.

According to an aspect of some embodiments of the invention, there is provided a method of generating an image of the surface of biological tissue, comprising:

- a) acquiring a first pixelated image of an area of interest of the surface at a first wavelength range of light, the first wavelength range including predominantly light having wavelengths of between about 400 nm and about 620 nm;
- b) acquiring a second pixelated image of the area of interest of the surface at a second wavelength range of light, the second wavelength range including predominantly light having wavelengths of between about 620 nm and about 800 nm;
- c) generating a monochromatic third pixelated image from the first image and the second image by:
 - for each desired location i of the area of interest, identifying a corresponding pixel $P1(i)$ in the first image and a corresponding pixel $P2(i)$ in the second image; and
 - calculating a pixel $P3(i)$ in the third image corresponding to the location i , by dividing one of $P1(i)$ and $P2(i)$ by the other.

According to an aspect of some embodiments of the invention, there is also provided a device useful for generating an image of the surface of biological tissue, comprising:

a) an image-acquirer suitable for acquiring a first pixelated image of an area of interest of the surface of biological tissue with a first wavelength range of light, the first wavelength range including predominantly light having wavelengths of between about 400 nm and about 620 nm;

5 b) an image-acquirer suitable for acquiring a second pixelated image of the area of interest with a second wavelength range of light, the second wavelength range including predominantly light having wavelengths of between about 620 nm and about 800 nm; and

10 c) a processor configured to generate a monochromatic third pixelated image from the first image and the second image by:

for each desired location i of an area of interest, identifying a corresponding pixel $P1(i)$ in the first image and a corresponding pixel $P2(i)$ in the second image; and

15 calculating a pixel $P3(i)$ in the third image corresponding to the location i , by dividing one of $P1(i)$ and $P2(i)$ by the other.

As used herein, for clarity the term "image" refers to a visible image (e.g., as displayed on permanent media such as on printed paper or electronic media such as a display screen (LED, LCD, CRT)), as well as data (especially electronic data) representing the image including data stored, for example, on magnetic or electrical media (e.g., flash memory, 20 magnetic disk, magnetic tape).

As used herein, for clarity the term "pixel" refers to an element making up a pixelated image (displayed or stored as data) and also to the value of the pixel, as the context dictates.

Unless otherwise defined, all technical and scientific terms used herein have the same meaning as commonly understood by one of ordinary skill in the art to which the invention 25 pertains. In case of conflict, the specification, including definitions, will control.

As used herein, the terms "comprising", "including", "having" and grammatical variants thereof are to be taken as specifying the stated features, integers, steps or components but do not preclude the addition of one or more additional features, integers, steps, components or groups thereof.

30 As used herein, the indefinite articles "a" and "an" mean "at least one" or "one or more" unless the context clearly dictates otherwise.

Embodiments of methods and/or devices described herein may involve performing or completing selected tasks manually, automatically, or a combination thereof. Some methods and/or devices described herein are implemented with the use of components that comprise

hardware, software, firmware or combinations thereof. In some embodiments, some components are general-purpose components such as general purpose computers, digital processors or oscilloscopes. In some embodiments, some components are dedicated or custom components such as circuits, integrated circuits or software.

5 For example, in some embodiments, some of an embodiment is implemented as a plurality of software instructions executed by a data processor, for example which is part of a general-purpose or custom computer. In some embodiments, the data processor or computer comprises volatile memory for storing instructions and/or data and/or a non-volatile storage, for example, a magnetic hard-disk and/or removable media, for storing instructions and/or
10 data. In some embodiments, implementation includes a network connection. In some embodiments, implementation includes a user interface, generally comprising one or more of input devices (e.g., allowing input of commands and/or parameters) and output devices (e.g., allowing reporting parameters of operation and results.

15 BRIEF DESCRIPTION OF THE FIGURES

Some embodiments of the invention are herein described with reference to the accompanying figures. The description, together with the figures, makes apparent to a person having ordinary skill in the art how some embodiments of the invention may be practiced. The figures are for the purpose of illustrative discussion and no attempt is made to show
20 structural details of an embodiment in more detail than is necessary for a fundamental understanding of the invention. For the sake of clarity, some objects depicted in the figures are not to scale.

In the Figures:

FIG. 1A is a reproduction of an image of the surface of the inner side of a flap of
25 abdominal skin of a mouse, with two regions marked: a region including a blood vessel (a) and a region devoid of blood vessels (b);

FIG. 1B are the reflectance spectra of regions a and b in Figure 1A between 400 nm and 800 nm;

FIG. 2A is a black-and-white reproduction of a standard RGB image of the surface of
30 the inner side of a flap of abdominal skin of a mouse;

FIG. 2B is a reproduction of a standard monochrome red-free narrow band (520 nm - 580 nm) image of the surface of the inner side of a flap of abdominal skin of a mouse;

FIG. 2C is a reproduction of an image of the surface of the inner side of a flap of abdominal skin of a mouse generated in accordance with an embodiment of the method as

described herein, where the first wavelength range was 400 nm to 600 nm and the second wavelength range was 600 nm to 800 nm;

FIG. 3 is a schematic depiction of an embodiment of a fundus camera device as described herein suitable for implementing embodiments of the method described herein including a single RGB multicolor image-acquirer;

FIG. 4 is a schematic depiction of an embodiment of an ingestible gastrointestinal imaging device as described herein suitable for implementing embodiments of the method described herein including a beam-splitter, two wavelength filters and two monochromatic image-acquirers;

FIG. 5 is a schematic depiction of an embodiment of a flexible endoscope device as described herein suitable for implementing embodiments of the method described herein including a dichroic prism and two monochromatic image-acquirers;

FIG. 6 is a schematic depiction of an embodiment of a rigid endoscope device as described herein suitable for implementing embodiments of the method described herein including two light sources and a single monochromatic image-acquirer; and

FIG. 7 is a schematic depiction of an embodiment of a rigid endoscope device as described herein suitable for implementing embodiments of the method described herein including two light sources and a single monochromatic image-acquirer; and

DESCRIPTION OF SOME EMBODIMENTS OF THE INVENTION

Some embodiments of the invention relate to methods and devices useful for imaging blood-containing tissue, for example for angiography, especially retinal angiography. In some embodiments, an image is generated by dividing pixels of an image acquired at some wavelength range by corresponding pixels of an image acquired at a different wavelength range. In some embodiments, a first wavelength range includes predominantly light having wavelengths between about 400 nm and about 620 nm and a second wavelength range includes predominantly light having wavelengths between about 620 nm and about 800 nm.

The principles, uses and implementations of the teachings of the invention may be better understood with reference to the accompanying description and figures. Upon perusal of the description and figures present herein, one skilled in the art is able to implement the teachings of the invention without undue effort or experimentation. In the figures, like reference numerals refer to like parts throughout.

Before explaining at least one embodiment of the invention in detail, it is to be understood that the invention is not necessarily limited in its application to the details of

construction and the arrangement of the components and/or methods set forth herein. The invention is capable of other embodiments or of being practiced or carried out in various ways. The phraseology and terminology employed herein are for descriptive purpose and should not be regarded as limiting.

5 Known methods for acquiring images of blood-containing tissue, such as in the field of angiography, have various shortcomings. Some methods require administration of compositions into the body, for example fluorescein or indocyanine compositions. Images acquired using known methods that do not include administration of such compositions are often insufficiently clear.

10 In Figure 1A an image of the surface of the inner side of a flap of abdominal skin of a mouse is reproduced with two regions marked: a region including a blood vessel (a) and a region devoid of blood vessels (b).

In Figure 1B are depicted the reflectance spectra of region a (blood vessel) and b (no blood vessel) between 400 nm and 800 nm as acquired by the Inventor using a spectral
15 imaging camera. It is seen that between 620 nm and 800 nm, the reflectance of blood-containing tissue (a) and tissue substantially devoid of blood (b) is substantially the same. It is also seen that between 400 nm and 620 nm, the reflectance of blood-containing tissue (a) is significantly lower than that of the tissue substantially devoid of blood (b), attributable to the absorption of light having such wavelengths by blood.

20 Herein are disclosed methods and devices useful for imaging blood-containing tissue, for example for angiography, especially retinal angiography. In some embodiments, an image is generated by dividing pixels of one image by corresponding pixels of another image, a first image acquired at a first wavelength range including predominantly light having higher absorbance in blood than non-blood bodily tissue, generally having wavelengths of between
25 about 400 nm and about 620 nm and a second image acquired at a second wavelength range including predominantly light having absorbance in blood similar to that of non-blood tissue generally having wavelengths of between about 620 nm and about 800 nm. It has been surprisingly found that in some embodiments, such a generated image has greater apparent detail due to higher contrast and/or greater spatial detail when compared to images acquired
30 using known methods.

In Figures 2, three different pixelated images of the same surface of the inner side of a flap of abdominal skin of a mouse acquired and generated by the Inventors using a spectral camera are depicted:

in Figure 2A, a standard RGB image of the surface is reproduced in black and white;

in Figure 2B, a standard monochrome red-free narrow band (520 nm - 580 nm) image of the surface is reproduced; and

in Figure 2C, an image generated in accordance with an embodiment of the method described herein (see Examples section) is reproduced where the first wavelength range was 400 nm to 600 nm and the second wavelength range was 620 nm to 800 nm.

Despite the relatively low quality of the reproductions in Figures 2A, 2B and 2C, it is seen that the teachings herein provide an image with greater apparent detail.

It is seen that the image in Figure 2C generated in accordance with the teachings herein has an unexpectedly superior contrast to the images in Figures 2A and 2B.

It is also seen that the image in Figure 2C generated in accordance with the teachings herein has an unexpectedly superior spatial resolution to the images in Figures 2A and 2B. Although not wishing to be held to any one theory, it is currently believed that in the known methods, the spatial resolution of the images is limited by the presence of photons at specific wavelengths back-scattered by the tissue including tubular walls of the blood vessels in the tissue. Apparently, the teachings herein reduce the effect of such back-scattered photons so that the edges of the blood vessels in an image generated in accordance with the teachings herein are more clearly defined.

Whatever the reasons, the teachings herein have exceptional utility, allowing acquisition of high contrast and/or detailed images, in some embodiments in real time, of capillaries, arteries, veins, hemorrhages and some blood-rich tumors. Images having greater spatial resolution and/or greater contrast make automated diagnosis methods (e.g., methods using image processing or image-comparison techniques) more accurate. Images having greater spatial resolution and/or greater contrast provide a health-care professional with more accurate information to diagnose some pathologies such as bleeding, cancer-related angiogenesis (e.g., retinal tumors such as melanoma), diabetic retinopathy, age-related macular degeneration and cardiovascular and brain diseases.

Method for generating an image

According to an aspect of some embodiments of the teachings herein, there is provided a method suitable for generating an image of the surface of biological tissue comprising:

- a) acquiring a first pixelated image of an area of interest of the surface at a first wavelength range of light, the first wavelength range including predominantly light having wavelengths of between about 400 nm and about 620 nm;

b) acquiring a second pixelated image of the area of interest of the surface at a second wavelength range of light, the second wavelength range including predominantly light having wavelengths of between about 620 nm and about 800 nm;

c) generating a monochromatic third pixelated image from the first image and the
5 second image by:

for each desired location i of an area of interest, identifying a corresponding pixel $P1(i)$ in the first image and a corresponding pixel $P2(i)$ in the second image; and

calculating a pixel $P3(i)$ in the third image corresponding to the location i , by

10 dividing one of $P1(i)$ and $P2(i)$ by the other.

The biological surface is any suitable biological surface. In some embodiments, the biological surface is a biological surface selected from the group consisting of a retina, skin, mucosa, gastrointestinal mucosa, oral mucosa, a gynecological tract surface, and a respiratory tract surface.

15 In some embodiments, the first image is a monochromatic image. In some embodiments, the second image is a monochromatic image.

In some embodiments, the third image has increased contrast between blood-containing features (such as blood vessels) and adjacent tissue, relative to comparable color or red-free images.

20 In some embodiments, the third image has increased spatial resolution at the border between blood-containing features (such as blood vessels) and adjacent tissue, relative to comparable color or red-free images.

Typically but not necessarily, the first, second and third images all are of the same size (in terms of pixels) and are of the same area of interest of the surface. Consequently,
25 during the generating of the third image, all pairs of corresponding pixels from the first and second image are used together to calculate a corresponding pixel of the third image.

In some embodiments, the first and second image are of the same size (in terms of pixels) and are of the same area of interest of the surface but the third image is smaller (e.g., of the same area of interest but fewer pixels to have lower resolution, or of a smaller area of
30 interest having the same or lower resolution). In such embodiments, the pixels constituting the third image are calculated from the corresponding pairs of pixels from the first and second image.

In some embodiments, one of the first and second image is smaller than the other (in terms of pixels) and/or in terms of the area of interest of the surface. In some such

embodiments, the third image is of the same size as the smaller of the first and second images. In some such embodiments, the third image is smaller and/or of a smaller area of interest. In such embodiments, the pixels constituting the third image are calculated from the corresponding pairs of pixels from the first and second image.

5 In some embodiments, the method further comprises storing the third image, for example on a flash memory (e.g., SD card) or magnetic memory (e.g., hard disk) data storage component. In some embodiments, the method further comprises displaying the third image in a manner visible to a person, for example on a display screen (e.g., LED, LCD or CRT display screen) or on permanent media (printed on paper or film). In some embodiments, the
10 displaying is in real time.

In some embodiments, the third image undergoes post-processing prior to storing and/or displaying. Typical post-processing includes, but is not limited to, cropping, rotation, resizing and changes in color depth.

In some embodiments, prior to the generating of the third image, the pixels of the first
15 image, of the second image or of both the first and the second image are normalized relative to some specific wavelength, for example for intensity balancing.

In some embodiments, a mathematical formula describing the calculating of a pixel of the third image from the two corresponding pixels of the first and second images is substantially a mathematical formula selected from the group consisting of:

20
$$P3(i) = [(xP1(i)+m)^A / (yP2(i)+n)^B]$$
 and
$$P3(i) = [(yP2(i)+n)^B / (xP1(i)+m)^A],$$
 wherein A and B are, independently, any suitable (preferably real) positive number except 0 and including 1; and wherein x and y are, independently, any suitable (preferably real) number including 1; and wherein m and n are, independently, any suitable (preferably real) number including 0.

25 In some embodiments, the mathematical formula is substantially a mathematical formula selected from the group consisting of $P3(i) = [P1(i) / P2(i)]$ and $P3(i) = [P2(i) / P3(i)]$.

In some embodiments, the method further comprises illuminating the area of interest with light comprising wavelengths within the first wavelength range during the acquiring of
30 the first pixelated image; and illuminating the area of interest with light comprising wavelengths within the second wavelength range during the acquiring of the second pixelated image. In some embodiments, the illuminating is with incoherent light. In some embodiments, the illuminating is with polarized light. In some embodiments, the illuminating with light comprising wavelengths within the first wavelength range is simultaneous with the

illuminating with light comprising wavelengths within the second wavelength range. In some such embodiments, the illuminating is with white light (e.g., a light-emitting diode emitting white light, a white-light lamp). In some such embodiments, the illuminating is with light having at least two discrete wavelengths of light: at least one discrete wavelength within the
5 first wavelength range (e.g., with a light-emitting diode emitting yellow, green or blue light) and at least one discrete wavelength within the second wavelength range (e.g., with a light-emitting diode emitting red light).

In some embodiments, the acquiring of the first pixelated image is not simultaneous with the acquiring of the second pixelated image, and the method further comprises:

10 illuminating the area of interest with light comprising wavelengths within the first wavelength range (e.g., with a light-emitting diode emitting yellow, green or blue light) during the acquiring of the first pixelated image; and
illuminating the area of interest with light comprising wavelengths within the second wavelength range (e.g., with a light-emitting diode emitting red light) during the
15 acquiring of the second pixelated image.

In some such embodiments, during the acquiring of the first pixelated image, illuminating the area of interest is with light substantially devoid of wavelengths within the second wavelength range. In some such embodiments, during the acquiring of the second pixelated image, illuminating the area of interest is with light substantially devoid of wavelengths
20 within the first wavelength range.

Generally, the first image and the second image are acquired using one or more pixelated image-acquirers as known in the field of digital photography, e.g., CCD arrays and CMOS arrays that typically use one or more arrays of light-sensitive sensors to acquire an image from light gathered by an objective.

25 In some embodiments, the first image and the second image are acquired substantially simultaneously.

For example, in some such embodiments the method comprises:

directing light collected for acquiring the first image from the area of interest to a first image-acquirer to acquire the first image; and
30 directing light collected for acquiring the second image from the area of interest to a second image-acquirer different from the first image-acquirer to acquire the second image.

In some embodiments, such directing of light is achieved using optical elements such as one or more of light filters, polarization filters, beam splitters, dichroic and trichroic prisms that direct the different wavelengths of light to the different image-acquirers.

For example, in some such embodiments the method comprises:

- 5 directing light collected for acquiring the first image and the second image from the area of interest to a single image-acquirer;
separating data acquired by the single image-acquirer constituting the first image from data acquired by the single image-acquirer constituting the second image.

In some embodiments, such separating of data is performed by using different color
10 outputs of a single-image-acquirer to generate the first and the second image. For example, in some such embodiments, an image-acquirer is a Foveon-X3 CMOS image-acquirer (National Semiconductor, Santa Clara, CA, USA) that has separate outputs for blue, green and red pixels. For example, in some such embodiments, an image-acquirer is a CCD or CMOS image-acquirer including a Bayer or other wavelength filter that has separate outputs for red,
15 green and blue pixels (RGB), or other wavelength filters such as red, green, blue, emerald pixels (RGBE filter), red, green, blue and white pixels (RGBW) and cyan, magenta, yellow and white pixels (CMYW).

In some embodiments, cross-polarization filters are used for illumination light and for collected light, which in some embodiments reduces or eliminates some of the negative
20 effects of specular reflections.

In some embodiments, the first and second image are acquired sequentially. To overcome the possibility that the area of interest moved in the frame of the images between acquisition of the first and second images, stitching algorithms (such as known in the field of digital photography) are typically used to match a pixel from the first image and a
25 corresponding pixel from the second image to calculate a corresponding pixel of the third image.

In some such embodiments, a device includes a single multicolor image-acquirer. In some such embodiments, a device includes a single monochrome image-acquirer.

For example, in some such embodiments, the image-acquirer is functionally
30 associated with a changing (e.g., rotating) wavelength filter that changes from a first state (that allows light from the first wavelength range to reach the image-acquirer) to a second state (that allows light from the second wavelength range to reach the image-acquirer). When the wavelength filter is in a first state, predominantly (in some embodiments only) light from the first wavelength range of light reaches the image-acquirer and the first image is acquired.

When the wavelength filter is in a second state, predominantly (in some embodiments, only) light from the second wavelength range of light reaches the image-acquirer and the second image is acquired.

For example, in some such embodiments, the area of interest is alternately illuminated
5 with light having different wavelengths. When the area of interest is illuminated predominantly with light having the first wavelength range of light, the first image is acquired. When the area of interest is illuminated predominantly with light having the second wavelength range the second image is acquired.

In any given embodiment, the first image is acquired at a first wavelength range of
10 light, that predominantly includes light having wavelengths of between about 400 nm and about 620 nm and the second image is acquired at a second wavelength range of light, that predominantly includes light having wavelengths of between about 620 nm and about 800.

In some embodiments, the first image is acquired at a first wavelength range of light, that exclusively includes light having wavelengths of between about 400 nm and about 620
15 nm: it is currently believed that in some instances such embodiments provide the greatest improvement in image-quality.

That said, in some embodiments the first image is acquired with some light having wavelengths of between about 620 nm and about 800. In such embodiments, the first wavelength range and the second wavelength range are together chosen to achieve the desired
20 improvement in image-quality.

In some embodiments, the second image is acquired at a second wavelength range of light, that exclusively includes light having wavelengths of between about 620 nm and about 800 nm: it is currently believed that in some instances such embodiments provide the greatest improvement in image-quality.

That said, in some embodiments the second image is acquired with some light having wavelengths of between about 400 nm and about 620. For example, the second image used in generating the image reproduced in Figure 2C included light having wavelengths of about 600 nm and 800 nm. In such embodiments, the first wavelength range and the second wavelength range are together chosen to achieve the desired improvement in image quality.
25
30 For example, in some embodiments, the first image is acquired at a first wavelength range of light, that exclusively includes light having wavelengths of between about 400 nm and about 620 nm (e.g., all light having a wavelength from 400 nm to 620 nm, or light having a wavelength from about 400 nm to about 600 nm) and the second image is acquired at a

second wavelength range of light, that includes light having wavelengths of between about 400 nm and about 800 nm.

In some embodiments, the first wavelength range is centered between a lower wavelength of about 400 nm (in some embodiments, between about 400 nm and about 450 nm) and an upper wavelength of about 620 nm (in some embodiments between about 550 nm and about 620 nm). In some embodiments, the first wavelength range is centered between a lower wavelength of about 450 nm and an upper wavelength of about 580 nm. In some embodiments, the first wavelength range is centered between a lower wavelength of about 480 nm and an upper wavelength of about 550 nm.

10 In some embodiments, the first wavelength range has a narrow bandwidth: e.g., having a bandwidth of less than about 5 nm, less than about 3 nm and even less than about 2 nm.

In some embodiments, the first wavelength range has a wide bandwidth, allowing more light to be gathered to acquire the first image with the concomitant high signal to noise ratio. In some such embodiments, the first wavelength range has a bandwidth of at least about 15 5 nm, at least about 10 nm, at least about 20 nm, at least about 40 nm and even at least about 80 nm.

In some embodiments, the first wavelength range is centered between a lower wavelength of about 620 nm (in some embodiments, between about 620 nm and about 650 nm) and an upper wavelength of about 800 nm (in some embodiments between about 700 nm and about 800 nm). In some embodiments, the second wavelength range is centered between a lower wavelength of about 620 nm and an upper wavelength of about 700 nm. In some embodiments, the second wavelength range is centered between a lower wavelength of about 620 nm and an upper wavelength of about 650 nm.

25 In some embodiments, the second wavelength range has a narrow bandwidth: e.g., having a bandwidth of less than about 5 nm, less than about 3 nm and even less than about 2 nm.

In some embodiments, the second wavelength range has a wide bandwidth, allowing more light to be gathered to acquire the second image with the concomitant high signal to noise ratio. In some such embodiments, the second wavelength range has a bandwidth of at least about 5 nm, at least about 10 nm, at least about 20 nm, at least about 40 nm and even at least about 80 nm.

Embodiments of the method may be implemented using any suitable device. For example, the first and second pixelated images may be acquired using a standard camera

(with required modification,. That said, in some embodiments it is preferable to use a device as described herein.

Device for generating an image

5 According to an aspect of some embodiments of the teachings herein, there is provided a device suitable for generating an image of the surface of biological tissue comprising:

- 10 a) an image-acquirer suitable for acquiring a first pixelated image of an area of interest of the surface of biological tissue with a first wavelength range of light, the first wavelength range including predominantly light having wavelengths of between about 400 nm and about 620 nm;
- b) an image-acquirer suitable for acquiring a second pixelated image of the area of interest of the surface of biological tissue with a second wavelength range of light, the second wavelength range including predominantly light having wavelengths of
15 between about 620 nm and about 800 nm;
- c) a processor configured to generate (in some embodiments, automatically) a monochromatic third pixelated image from the first image and the second image by:
 - for each desired location i of an area of interest, identifying a corresponding
20 pixel $P1(i)$ in the first image and a corresponding pixel $P2(i)$ in the second image; and
 - calculating a pixel $P3(i)$ in the third image corresponding to the location i , by dividing one of $P1(i)$ and $P2(i)$ by the other.

The device is any suitable device. In some embodiments, the device is a device selected from the group consisting of a medical camera, an ingestible endoscope, an
25 endoscope, an ophthalmoscope and a fundus camera.

The first wavelength range is any suitable wavelength range, as described above. The second wavelength range is any suitable wavelength range, as described above.

The calculating is performed substantially as described above.

In some embodiments, the device further comprises an illuminator configured: to
30 illuminate an area of interest with light comprising wavelengths within the first wavelength range during acquisition of a first pixelated image; and to illuminate an area of interest with light comprising wavelengths within the second wavelength range during acquisition of a second pixelated image. In some embodiments, the illumination light is incoherent light. In some embodiments, the illumination light is polarized light.

In some embodiments, the illuminator is configured to simultaneously illuminate an area of interest with light comprising wavelengths within the first wavelength range and wavelengths within the second wavelength range. In some such embodiments, the illuminator includes a source of white light. In some such embodiments, the illuminator includes a source of at least two discrete wavelengths of light, at least one discrete wavelength of light within the first wavelength range and at least one discrete wavelength of light within the second wavelength range.

In some embodiments, the illuminator includes a source of at least two discrete wavelengths of light, at least one discrete wavelength of light within the first wavelength range and at least one discrete wavelength of light within the second wavelength range, and the device is configured:

to illuminate an area of interest with a discrete wavelength of light within the first wavelength range only during acquisition of first pixelated image; and
to illuminate an area of interest with a discrete wavelength of light within the second wavelength range only during acquisition of second pixelated image.

In some embodiments, the image-acquirer suitable for acquiring the first pixelated image and the image-acquirer suitable for acquiring the second pixelated image are the same image-acquirer, generally a multicolor image-acquirer.

In some embodiments, the image-acquirer suitable for acquiring the first pixelated image and the image-acquirer suitable for acquiring the second pixelated image are different image-acquirers, in some embodiments monochrome image-acquirers and in some embodiments multicolor image-acquirers. In some embodiments, the device further comprises at least one optical element to direct light of the first wavelength range to the first-image acquirer and light of the second wavelength range to the second-image acquirer.

In some embodiments, the device is configured to acquire the first image and the second image substantially simultaneously.

In some such embodiments, the device comprises an optical element that directs light gathered by an objective to different image-acquirers (monochrome or multicolor), at least one image-acquirer configured to acquire the first image and at least one image-acquirer configured to acquire the second image. In some such embodiments, the optical element is, for example, a dichroic prism or a trichroic prism that directs light from the first wavelength range to the first-image acquirer or acquirers and directs light from the second wavelength range to the second-image acquirer or acquirers. In some such embodiments, the optical element is, for example, a beam splitter, that directs some light to the first-image acquirer or

acquirers through a wavelength filter that allows only light of the first wavelength range to pass and directs some light to the second-image acquirer or acquirers through a wavelength filter that allows only light of the second wavelength range to pass.

In some such embodiments, the device comprises a single multicolor image-acquirer
5 configured to acquire both the first and the second image, In some such embodiments, the multicolor image-acquirer has separate outputs for each color, for example a Foveon-X3 CMOS image-acquirer that has separate outputs for blue, green and red pixels or a CCD or CMOS image-acquirer including a Bayer or other wavelength filter that has separate outputs for red, green and blue pixels (RGB), or other wavelength filters such as red, green, blue,
10 emerald pixels (RGBE filter).

In some embodiments, the device is configured to acquire the first image and the second image sequentially. In some such embodiments, the device comprises a single image-acquirer, in some embodiments a multicolor image-acquirer, in some embodiments a monochrome image-acquirer. In some embodiments, the image-acquirer is functionally
15 associated with a changing (e.g., rotating) wavelength filter that changes from a first state (that allows light from the first wavelength range to reach the image-acquirer) to a second state (that allows light from the second wavelength range to reach the image-acquirer). When the wavelength filter is in a first state, the device is configured to acquire a first image as only light from the first wavelength range of light reaches the image-acquirer and the first image is
20 acquired. When the wavelength filter is in a second position, the device is configured to acquire a second image as only light from the second wavelength range of light reaches the image-acquirer and the second image is acquired.

In some embodiments, the device includes an illuminator configured to alternately illuminate an area of interest with light having different wavelengths. The device is
25 configured to acquire a first image when an area of interest is illuminated with light of the first wavelength range of light and to acquire a second image when the area of interest is illuminated with light of the second wavelength range of light.

In some embodiments, the device is configured to store an acquired first image and an acquired second image. In some embodiments, the device is configured to store the third
30 image.

In some embodiments, the device further comprises a display component configured to visually display a generated third image. In some embodiments, the device further comprises a display component configured to automatically visually display a generated third

image. In some embodiments, the device further comprises a display component configured to visually display a generated third image upon receipt of command from a user.

In some embodiments, the device further comprises an illuminator configured to illuminate an area of interest with light comprising both the first wavelength range and the second wavelength range. In some embodiments, the illumination with the first wavelength range is simultaneous with illumination with the second wavelength range. In some embodiments, the illumination with the first wavelength range is separate from the illumination with the second wavelength range. In some embodiments, the light is incoherent light. In some embodiments, the illuminator is configured to illuminate the area of interest with white light. In some embodiments, the light source is configured to illuminate the surface of biological tissue with either light of the first wavelength range or light of the second wavelength range at any one time.

An embodiment of a device useful for generating an image of the surface of biological tissue, specifically a fundus camera **10** for generating an image of a retina, is schematically depicted in Figure 3.

Device **10** is similar to known fundus cameras. Device **10** comprises an illuminator **12**, configured to illuminate an area of interest of a retina with white incoherent light including substantially all wavelengths of light from 400 to 800 nm. Device **10** also comprises an objective **14**, to gather light reflected from a retina and focus the light onto the light-detecting surface of a single multicolor image-acquirer **16**, a 12-megapixel CMOS RGB detector array with a Bayer filter, having separate red pixels output **18**, green pixels output **20** and blue pixel output **22**. A processor **24** is configured to receive outputs **18**, **20** and **22** and to generate a third image from the outputs in accordance with the teachings herein. Processor **24** is functionally associated with a memory **26** (an SDHC flash memory) to store acquired images and generated images. Processor **24** is also functionally associated with a display screen **28**, a LED display screen.

For use, the chin of a subject is rested on chin-rest **29** so that the eye of a subject is appropriately positioned relative to objective **14**. Illuminator **12**, image-acquirer **16** and processor **24** are activated. Light from illuminator **12** is reflected from the area of interest of the retina and focused onto the light-detecting surface of image-acquirer **16** which simultaneously acquires data corresponding to three monochromatic images that are separately directed to processor **24**: a red image through red pixel output **18**, a green image

through green pixel output **20** and a blue image through blue pixel output **22**. Processor **24** stores the three acquired images in memory **26**.

Depending on the user instructions (that can be changed through a device-user interface, not depicted), processor **24** generates an image from at least two of the acquired
5 images, stores the generated image in memory **26** and automatically displays the generated image on display screen **28** in real time.

The user can instruct processor **26** to generate a third image as described above from:

the green image as a first image and the red image as a second image;

the blue image as a first image and the red image as a second image; or

10 a combination (e.g., sum or weighted sum) of the blue and green images as a first image and the red image as a second image.

Image-acquirer **16** of device **10** is a CMOS (complementary metal oxide) RGB detector array with a Bayer filter, having separate red pixels output **18**, green pixels output **20** and blue pixel output **22**. In some related embodiments an image-acquirer is another detector
15 technology, for example, a CCD (charge-coupled device) array, a PD (photodiode) array, or a LED (light-emitting diode) array. In some related embodiments, the image-acquirer is RGB but with a filter different from a Bayer filter (e.g., a filter similar to the filter used in a S9706 color sensor by Hamamatsu Photonics K.K. (Hamamatsu, Japan)) or a Foveon-X3 CMOS image-acquirer.

20 In some related embodiments, an image-acquirer has other colors. For example, in some embodiments the image-acquirer is an RGBE image-acquirer with four separate outputs: a red pixel output for acquiring a red image, a green pixel output for acquiring a green image, a blue pixel output for acquiring a blue image and an emerald pixel output for acquiring an emerald image. In some such embodiments, any of the green, blue and emerald
25 images, singly or in combination of two or combination of three can be used a first image as described herein while the red image is used as a second image.

It is important to note that often the spectral response of a multicolor image-acquirer to a specific color is far from monochromatic. For example, the red of a typical Bayer filter has a peak sensitivity to light having wavelengths of 610 to 630 nm, that is gradually reduced
30 towards 800 nm and is sharply reduced, but still significant down to 570 nm. Consequently, in some embodiments a second image such as a red image in the embodiment described above, includes wavelengths outside the range of 620 nm to 800 nm.

An additional embodiment of a device useful for generating an image of the surface of biological tissue, specifically an ingestible device **30** for gastrointestinal imaging is schematically depicted in Figure 4.

Device **30** is similar to known ingestible devices for gastrointestinal imaging such as the Pillcam™ (Given Imaging, Yokneam, Israel). Device **30** comprises an illuminator **12**, configured to illuminate an area of interest of intestinal mucosa with white incoherent light including substantially all wavelengths of light from 400 to 800 nm. Device **30** also comprises an objective **14**, to gather light reflected from the intestinal mucosa of a gastrointestinal tract in which device **30** is found and focus the light towards a beam-splitter **32**, a half-silvered mirror, that directs light from objective **14** in two directions: in a first direction **34a** through a first wavelength filter **36a** (configured to pass light having a wavelength less than 620 nm and to block light having a wavelength greater than 620 nm) to impinge on the light-sensitive surface of a first image-acquirer **38a**, a 12 megapixel monochrome CCD detector array and in a second direction **34b** through a second wavelength filter **36b** (configured to pass light having a wavelength greater than 620 nm and to block light having a wavelength less than 620 nm) to impinge on the light-sensitive surface of a second image-acquirer **38b**, a 12 megapixel monochrome CCD detector array. Suitable wavelength filters are available, for example, from Lee Filters, Andover, Hampshire, England.

A processor **24** is configured to periodically receive acquired images from first image-acquirer **38a** and second image-acquirer **38b**, and to generate a third image from the images in accordance with the teachings herein. As known in the art of ingestible gastrointestinal imaging devices, processor **24** is functionally associated with a wireless Bluetooth® transmitter **40** that transmits acquired images and generated images to an external unit (not depicted). The various components of device **30** receive electrical power required for operation from power source **42**, a lithium ion battery.

For use, device **30** is activated and ingested by a subject. Illuminator **12**, image-acquirers **38a** and **38b**, processor **24** and transmitter **40** are activated. As device **30** is propelled through the gastrointestinal tract of the subject, light from illuminator **12** is reflected from areas of interest of the intestinal mucosa retina and directed by objective **14** and beam-splitter **32** in first direction **34a** and second direction **34b**. Light traveling in first direction **34a** passes through first wavelength filter **36a** to the light sensitive surface of first image-acquirer **38a**, that acquires a first image from the light. Light traveling in second direction **34b** passes through second wavelength filter **36b** to the light sensitive surface of

second image-acquirer **38b**, that acquires a second image from the light. Processor **24** receives the acquired first and second images from the respective image-acquirers **38** and generates a third image from the first and second images substantially as described above. Processor **24** then transmits the acquired images and the generated image to an external unit
5 using transmitter **40**.

In embodiments related to device **30**, the device transmits acquired first images and second images to an external unit, and the external unit is configured to generate a third image from the acquired first and second images.

In some embodiments related to device **30**, illuminator **12** comprises a white-light
10 illumination source, such as a white-light emitting LED, to provide simultaneous illumination with light having wavelengths in both the first and second wavelength range.

In some embodiments related to device **30**, illuminator **12** comprises at least two discrete light sources (e.g., colored-light emitting LEDs) to provide simultaneous illumination with light having wavelengths in both the first (e.g., 420 nm or 560 nm) and the
15 second wavelength range (e.g., 620 nm).

An additional embodiment of a device useful for generating an image of the surface of biological tissue, specifically a flexible endoscope **44** for imaging the inner surfaces of bodily hollows is schematically depicted in Figure 5. Device **44** comprises a flexible shaft **46** having a distal end **48** schematically depicted in detail in Figure 5. Not depicted in Figure 5 is the
20 bulk of shaft **46**, the proximal end of device **44**, as well as other components such as steering components well known in the art of endoscopy.

Device **44** is similar to known flexible endoscopes. Device **44** comprises an illuminator **12**, configured to illuminate an area of interest of a surface of a bodily hollow with white incoherent light including substantially all wavelengths of light from 400 to 800
25 nm. Device **44** also comprises an objective **14**, to gather light reflected from the area of interest at which illuminator **12** is directed and focus the light towards a dichroic prism **50**, that directs light from objective **14** in two directions: light having a wavelength of less than 600 nm is directed in a first direction **34a** to impinge on the light-sensitive surface of a first image-acquirer **38a**, a 12 megapixel monochrome CCD detector array while light having a
30 wavelength of greater than 600 nm is directed in a second direction **34b** to impinge on the light-sensitive surface of a second image-acquirer **38b**, a 12 megapixel monochrome CCD detector array. Suitable dichroic prisms are available, for example, from Optec, Parabiago, Milano, Italy.

A processor **24** is configured to periodically receive acquired images from first image-acquirer **38a** and second image-acquirer **38b**, and to generate a third image from the images in accordance with the teachings herein. Processor **24** transmits acquired images for storage and generated images for storage and display to an external unit (not depicted) through communication cable **52** that passes through shaft **46** to the distal end of device **44**. The various components of device **44** receive electrical power required for operation through lead **54**.

For use, device **44** is activated and inserted into a hollow of a subject as known in the art. Illuminator **12**, image-acquirers **38a** and **38b** and processor **24** are activated. As device **44** is steered inside the hollow, light from illuminator **12** is reflected from areas of interest of the inner surface of the hollow and directed by objective **14** and dichroic prism **50** in first direction **34a** and second direction **34b**. Light traveling in first direction **34a** reaches the light sensitive surface of first image-acquirer **38a**, that acquires a first image from the light. Light traveling in second direction **34b** reaches the light sensitive surface of second image-acquirer **38b**, that acquires a second image from the light. Processor **24** receives the acquired first and second images from the respective image-acquirers **38** and generates a third image from the first and second images substantially as described above. Processor **24** then transmits the acquired images and the generated image to an external unit through communication cable **52**.

In embodiments related to device **30**, the device transmits acquired first images and second images to an external unit, and the external unit is configured to generate a third image from the acquired first and second images. The generated image is displayed in real time, on a display device.

It is important to note that depending on the exact embodiment, device **44** is substantially any suitable type of flexible endoscope including, but not limited to, an esophagogastroduodenoscope, an enteroscope, a cholangiopancreatroscope, a colonoscope, a sigmoidoscope, a rhinoscope, a bronchoscope, a cystoscope, a gynoscope, a hysteroscope, a falloposcope, an amnioscope, a gastroscope, an otoscope, a laparoscope, a panendoscope or a fetoscope.

In device **44**, the image-acquiring components are found at distal end **48** of device **44**. In some embodiments, the image-acquiring components are found at the proximal end of the device and light from an area of interest on a surface of tissue is directed through a light guide (e.g., an optical fiber) passing from distal end **48** through flexible shaft **46** to the proximal end.

In a related non-depicted embodiment, a device as described herein includes a trichroic prism (or even an n-chroic prism, where n is greater than 3) instead of a dichroic prism to direct different wavelength ranges of light from objective **14** in different directions. At least two different wavelength ranges, in some embodiments more, are directed each to a different image-acquirer to acquire an image. A first image and a second image, as described hereinabove, are acquired and used to generate a third image in accordance with the teachings herein.

An additional embodiment of a device useful for generating an image of the surface of biological tissue, specifically a rigid endoscope **56** (e.g., suitable for use as a laparoscope during keyhole surgery) for imaging the inner surfaces of bodily hollows is schematically depicted in Figure 6. Device **56** comprises a rigid shaft **58** having a proximal end **60** schematically depicted in Figure 6. Not depicted in Figure 6 is the bulk of shaft **58**, the distal end of device **56**, as well as other components well known in the art of endoscopy.

Device **56** is similar to known rigid endoscopes. Device **56** comprises an illuminator **12**. Illuminator **12** includes a white incoherent light source that is functionally associated with a changeable wavelength filter **62** having two states (determined, for example, by a rotating disk bearing two different wavelength filters). In a first state, light having a wavelength of less than 620 nm passes through changeable wavelength filter **62** into an illumination channel **64** that passes through shaft **58** to emerge through the distal tip of shaft **58** to illuminate an area of interest of a surface of bodily tissue, while light having a wavelength greater than 620 nm is blocked by changeable wavelength filter **62**. In a second state, light having a wavelength of greater than 620 nm passes through changeable wavelength filter **62** into an illumination channel **64** that passes through shaft **58** to emerge through the distal tip of shaft **58** to illuminate an area of interest of a surface of bodily tissue, while light having a wavelength less than 620 nm is blocked by changeable wavelength filter **62**. A processor **24** is configured to control the state of changeable wavelength filter **62**.

Passing from the distal tip of shaft **58** is a light guide **66** (an optical fiber as known in the art of endoscopy) that directs light from the distal tip of shaft **58** to an objective **14**. Objective **14** focuses light gathered from the distal tip of shaft **58** at the light-sensitive surface of an image-acquirer **38**, a 12 megapixel multicolor (in some related embodiments, monochrome) CCD detector array.

Processor **24** is configured to repeatedly accept an image acquired by image-acquirer **38** when changeable wavelength filter **62** is in the first state as a first acquired image, then change the state of changeable wavelength filter **62** to the second state and accept an image

acquired by image-acquirer **38** when changeable wavelength filter **62** is in the second state as a second acquired image. Thus, device **56** is configured to acquire the first image and the second image sequentially.

Using an algorithm based on standard stitching algorithms known in the art of digital
5 photography, processor **24** is configured to identify corresponding pixels of an acquired first image and a succeeding or preceding acquired second image, and generate a third image from pairs of corresponding pixels from acquired first and second images in accordance with the teachings herein. Processor **24** transmits acquired images for storage and generated images for storage and display to an external unit (not depicted) through communication cable **52**.

10 For use, device **56** is activated and inserted into a hollow of a subject as known in the art, e.g., through a surgical port. Illuminator **12**, image-acquirer **38** and processor **24** are activated. The distal end of device **56** is directed at a surface so that light from illuminator **12** passes through illumination channel **64** towards an area of interest, and is reflected. Reflected light is directed through light guide **66** to objective **14**. Objective **14** directs the light to the
15 light sensitive surface of image-acquirer **38**, that alternately acquires a first image and a second image depending on the state of changeable wavelength filter **62**, as described above. Processor **24** receives the acquired first and second images from image-acquirer **38** and generates a third image from the first and second images substantially as described above. Processor **24** then transmits a generated image to be displayed on a display unit in real time.

20 In some embodiments described above, an illuminator configured to produce white light is used to illuminate an area of interest. In some alternate embodiments, a device includes an illuminator configured to produce a limited number of wavelengths of light to illuminate an area of interest. In such embodiments, at least one wavelength is between about 400 nm and about 620 nm (preferably between 475 nm and 560 nm where the difference in
25 reflectance between blood and no blood is most pronounced) and at least one wavelength is between about 620 nm and about 800 nm (preferably between about 620 nm and 675 nm where the intensity of reflectance is highest). Typically, such an illuminator includes two separate light sources such as two monochromatic LEDs

An additional embodiment of a device useful for generating an image of the surface of
30 biological tissue, specifically a rigid endoscope **68** (e.g., suitable for use as a laparoscope during keyhole surgery) for imaging the inner surfaces of bodily hollows is schematically depicted in Figure 7.

Like device **56**, device **68** is similar to known rigid endoscopes comprising a rigid shaft **58** having a proximal end **60**. Device **68** comprises an illuminator **12** including two

independently activatable substantially-monochromatic incoherent light sources, light-emitting diode **70a** (green LED emitting light at 500 nm) and light-emitting diode **70b** (red LED emitting light at 630 nm). When one or both LEDs **70a** or **70b** are activated, the emitted light passes into and through an illumination channel **64** that passes through shaft **58** to
5 emerge through the distal tip of shaft **58** to illuminate an area of interest of a surface of bodily tissue.

Like in device **56**, passing from the distal tip of shaft **58** is a light guide **66** that directs light from the distal tip of shaft **58** to an objective **14**. Objective **14** focuses light gathered from the distal tip of shaft **58** at the light-sensitive surface of an image-acquirer **38**, a 12
10 megapixel multicolor (in some related embodiments, monochrome) CCD detector array.

Processor **24** is configured to repeatedly activate LED **70a** to illuminate an area of interest with monochromatic light having a wavelength of 500 nm and accept an image acquired by image-acquirer **38** as a first acquired image, and then to activate LED **70b** to illuminate an area of interest with monochromatic light having a wavelength of 630 nm and
15 accept an image acquired by image-acquirer **38** as a second acquired image. Thus, device **68** is configured to acquire the first image and the second image sequentially.

Like in device **56**, processor **24** of device **68** is configured to identify corresponding pixels of an acquired first image and a succeeding or preceding acquired second image, and generate a third image from pairs of corresponding pixels from acquired first and second
20 images in accordance with the teachings herein. Processor **24** transmits acquired images for storage and generated images for storage and display to an external unit (not depicted) through communication cable **52**.

For use, device **68** is activated and inserted into a hollow of a subject as known in the art, e.g., through a surgical port. Illuminator **12**, image-acquirer **38** and processor **24** are
25 activated. The distal end of device **68** is directed at a surface so that light from illuminator **12** passes through illumination channel **64** towards an area of interest, and is reflected. Reflected light is directed through light guide **66** to objective **14**. Objective **14** directs the light to the light sensitive surface of image-acquirer **38**, that alternately acquires a first image and a second image depending on which LED **70a** or **70b** of illuminator **12** is activated, as
30 described above. Processor **24** receives the acquired first and second images from image-acquirer **38** and generates a third image from the first and second images substantially as described above. Processor **24** then transmits a generated image to be displayed on a display unit in real time.

Depending on the exact embodiment, devices **56** and **68** are substantially any suitable type of rigid endoscope including, but not limited to, a laparoscope, an anoscope, a proctoscope, a rectoscope, an otoscope, a colposcope, an arthroscope, a thoracoscope, a sigmoidoscope, a rhinoscope, a bronchoscope, a cystoscope, a gynoscope, a gastroscope, a
5 mediastinoscope, a panendoscope and a hysteroscope.

EXAMPLES

Example 1

A first laboratory mouse was anesthetized . The skin covering the abdominal cavity
10 was cut to define a loose flap, and the flap secured with needles to a flat surface, skin side down.

Using an SD-300 spectral imaging camera (ASI, Migdal Haemek, Israel) fitted with a halogen lamp illuminator and a cross-polarizing filter set, a spectral image of a portion of the inner surface of the flap was acquired between 400 nm and 800 nm. The acquired image is
15 reproduced, in black-and-white, in Figure 1A. In Figure 1B, the spectrum of a portion of the image where a blood vessel was present (portion a) and the spectrum of the image where no blood vessel was present (portion b) are displayed.

Example 2

A second laboratory mouse was anesthetized . The skin covering the abdominal cavity
20 was cut to define a loose flap, and the flap secured with needles to a flat surface, skin side down.

Using an SD-300 spectral imaging camera (ASI, Migdal Haemek, Israel) fitted with a halogen lamp illuminator and a cross-polarizing filter set, a spectral image of a portion of the
25 inner surface of the flap was acquired between 400 nm and 800 nm.

An RGB image including all the image data acquired between 400 nm and 800 nm is reproduced in black-and -white in Figure 2A.

A red-free narrow band (520 nm - 580 nm) monochrome image using data acquired between is reproduced in black-and-white in Figure 2B. Although the contrast is superior to
30 the equivalent RGB image, the spatial resolution appears to be similar.

An image generated in accordance with an embodiment of the method described herein where the first wavelength range was 400 nm to 600 nm and the second wavelength range was 600 nm to 800 nm, and the mathematical formula describing the calculation of a pixel of the generated third image from the two corresponding pixels of the first and second

images is: $P3(i) = [P1(i) / P2(i)]$. It is seen that the contrast and the spatial resolution of the generated image is significantly better than of both the RGB and the red-free image.

Although the invention has been described in conjunction with specific embodiments thereof, it is evident that many alternatives, modifications and variations will be apparent to those skilled in the art. Accordingly, it is intended to embrace all such alternatives, modifications and variations that fall within the scope of the appended claims.

For example, in some embodiments, any of the imaging assemblies described herein, such as the specific imaging assemblies described in detail with reference to a specific embodiment of the device: fundus camera **10**, ingestible device **30**, flexible endoscope **44**, or a flexible endoscope **56** are used in other devices. For example, in some embodiments an imaging assembly such as described with reference to fundus camera **10** is used in an ingestible device, a flexible endoscope or a rigid endoscope (laparoscope).

It is appreciated that certain features of the invention, which are, for clarity, described in the context of separate embodiments, may also be provided in combination in a single embodiment. Conversely, various features of the invention, which are, for brevity, described in the context of a single embodiment, may also be provided separately or in any suitable subcombination or as suitable in any other described embodiment of the invention. Certain features described in the context of various embodiments are not to be considered essential features of those embodiments, unless the embodiment is inoperative without those elements.

Citation or identification of any reference in this application shall not be construed as an admission that such reference is available as prior art to the invention.

Section headings are used herein to ease understanding of the specification and should not be construed as necessarily limiting.

CLAIMS:

1. A method of generating an image of the surface of biological tissue, comprising:
 - a) acquiring a first pixelated image of an area of interest of the surface at a first wavelength range of light, said first wavelength range including predominantly light having wavelengths of between about 400 nm and about 620 nm;
 - b) acquiring a second pixelated image of said area of interest of the surface at a second wavelength range of light, said second wavelength range including predominantly light having wavelengths of between about 620 nm and about 800 nm;
 - c) generating a monochromatic third pixelated image from said first image and said second image by:
 - for each desired location i of said area of interest, identifying a corresponding pixel $P1(i)$ in said first image and a corresponding pixel $P2(i)$ in said second image; and
 - calculating a pixel $P3(i)$ in said third image corresponding to said location i , by dividing one of $P1(i)$ and $P2(i)$ by the other.
2. The method of claim 1, further comprising, displaying said third image.
3. The method of any of claims 1 to 2, wherein a mathematical formula describing said calculating is substantially a mathematical formula selected from the group consisting of:

$$P3(i) = [(xP1(i)+m)^A / (yP2(i)+n)^B] \text{ and } P3(i) = [(yP2(i)+n)^B / (xP1(i)+m)^A],$$
 wherein A and B are, independently, any suitable positive number except 0 and including 1; wherein x and y are, independently, any suitable number including 1; and wherein m and n are, independently, any suitable number including 0.
4. The method of any of claims 1 to 3, wherein said mathematical formula is substantially a mathematical formula selected from the group consisting of $P3(i) = [P1(i) / P2(i)]$ and $P3(i) = [P2(i) / P3(i)]$.
5. The method of any of claims 1 to 4, further comprising:
 - illuminating said area of interest with light comprising wavelengths within said first wavelength range during said acquiring of said first pixelated image; and
 - illuminating said area of interest with light comprising wavelengths within said second wavelength range during said acquiring of said second pixelated image.

6. The method of claim 5, wherein said illuminating with light comprising wavelengths within said first wavelength range is simultaneous with said illuminating with light comprising wavelengths within said second wavelength range.
7. The method of claim 6, wherein said illuminating is with white light.
8. The method of claim 6, wherein said illuminating is with light having at least two discrete wavelengths of light: at least one discrete wavelength within said first wavelength range and at least one discrete wavelength within said second wavelength range.
9. The method of any of claims 1 to 4, wherein said acquiring of said first pixelated image is not simultaneous with said acquiring of said second pixelated image, and further comprising:
 - illuminating said area of interest with light comprising wavelengths within said first wavelength range during said acquiring of said first pixelated image; and
 - illuminating said area of interest with light comprising wavelengths within said second wavelength range during said acquiring of said second pixelated image.
10. The method of any of claims 5 to 9, wherein said illuminating is with incoherent light.
11. The method of any of claims 1 to 10, wherein said first pixelated image and said second pixelated image are acquired substantially simultaneously.
12. The method of claim 11, comprising:
 - directing light collected for acquiring said first image from said area of interest to a first image-acquirer to acquire said first image; and
 - directing light collected for acquiring said second image from said area of interest to a second image-acquirer different from said first image-acquirer to acquire said second image.
13. The method of claim 11, comprising:
 - directing light collected for acquiring said first image and said second image from said area of interest to a single image-acquirer;

separating data acquired by said single image-acquirer constituting said first image from data acquired by said single image-acquirer constituting said second image.

14. The method of any of claims 1 to 10, wherein said first image and said second image are acquired sequentially.
15. The method of any of claims 1 to 14, wherein said first range of wavelengths is centered between a lower wavelength of about 400 nm and an upper wavelength of about 620 nm.
16. The method of any of claims 1 to 15, wherein said second range of wavelengths is centered between a lower wavelength of about 620 nm and an upper wavelength of about 800 nm.
17. The method of any of claims 1 to 16, wherein the biological surface is a biological surface selected from the group consisting of a retina, skin, mucosa, gastrointestinal mucosa, oral mucosa, a gynecological tract surface, and a respiratory tract surface.
18. A device useful for generating an image of the surface of biological tissue, comprising:
 - a) an image-acquirer suitable for acquiring a first pixelated image of an area of interest of the surface of biological tissue with a first wavelength range of light, said first wavelength range including predominantly light having wavelengths of between about 400 nm and about 620 nm;
 - b) an image-acquirer suitable for acquiring a second pixelated image of said area of interest with a second wavelength range of light, said second wavelength range including predominantly light having wavelengths of between about 620 nm and about 800 nm; and
 - c) a processor configured to generate a monochromatic third pixelated image from said first image and said second image by:
 - for each desired location i of a said area of interest, identifying a corresponding pixel $P1(i)$ in said first image and a corresponding pixel $P2(i)$ in said second image; and

calculating a pixel $P3(i)$ in said third image corresponding to said location i , by dividing one of $P1(i)$ and $P2(i)$ by the other.

19. The device of claim 18, wherein said device is configured to acquire said first image and said second image substantially simultaneously.
20. The device of claim 18, wherein said device is configured to acquire said first image and said second image sequentially.
21. The device of any of claims 18 to 20, wherein said image-acquirer suitable for acquiring said first pixelated image and said image-acquirer suitable for acquiring said second pixelated image are the same image-acquirer.
22. The device of any of claims 18 to 20, wherein said image-acquirer suitable for acquiring said first pixelated image and said image-acquirer suitable for acquiring said second pixelated image are different image-acquirers.
23. The device of any of claims 18 to 22, further comprising a display component configured to visually display a said generated third image.
24. The device of any of claims 18 to 23, further comprising an illuminator configured: to illuminate an area of interest with light comprising wavelengths within said first wavelength range during acquisition of a said first pixelated image; and to illuminate an area of interest with light comprising wavelengths within said second wavelength range during acquisition of a said second pixelated image.
25. The device of claim 24, wherein said light is incoherent light.
26. The device of any of claims 24 to 25, said illuminator is configured to simultaneously illuminate said area of interest with light comprising wavelengths within said first wavelength range and wavelengths within said second wavelength range.
27. The device of claim 26, wherein said illuminator includes a source of white light.

28. The device of claim 26, wherein said illuminator includes a source of at least two discrete wavelengths of light, at least one discrete wavelength of light within said first wavelength range and at least one discrete wavelength of light within said second wavelength range.

29. The device of claim 26, wherein said illuminator includes a source of at least two discrete wavelengths of light, at least one discrete wavelength of light within said first wavelength range and at least one discrete wavelength of light within said second wavelength range,

the device configured:

to illuminate said area of interest with said discrete wavelength of light within said first wavelength range only during acquisition of a said first pixelated image; and
to illuminate said area of interest with said discrete wavelength of light within said second wavelength range only during acquisition of a said second pixelated image.

30. The device of any of claim 18 to 29, wherein the device is a device selected from the group consisting of an ingestible endoscope, an endoscope, an ophthalmoscope and a fundus camera.

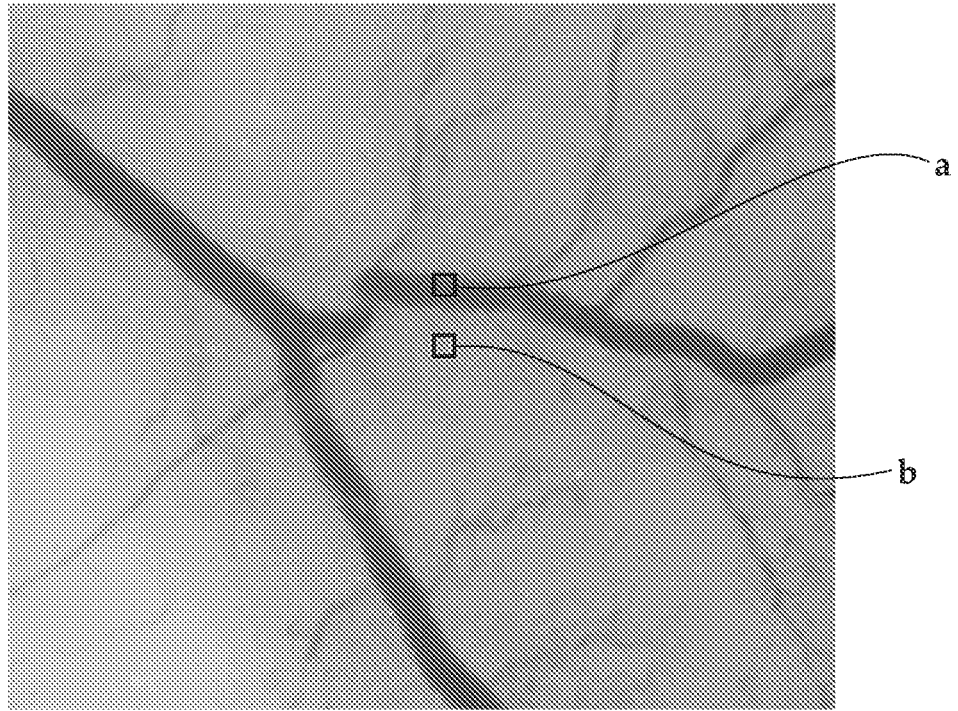

FIG. 1A

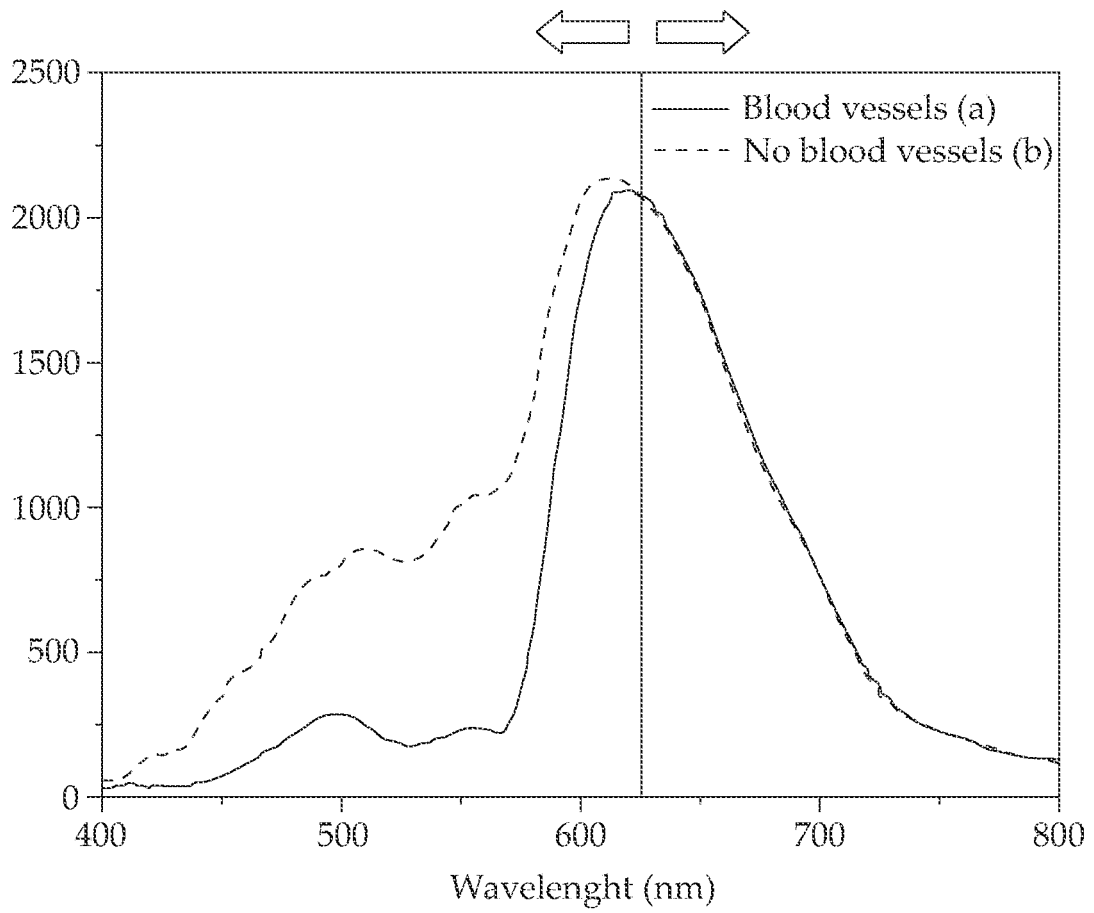

FIG. 1B

2/7

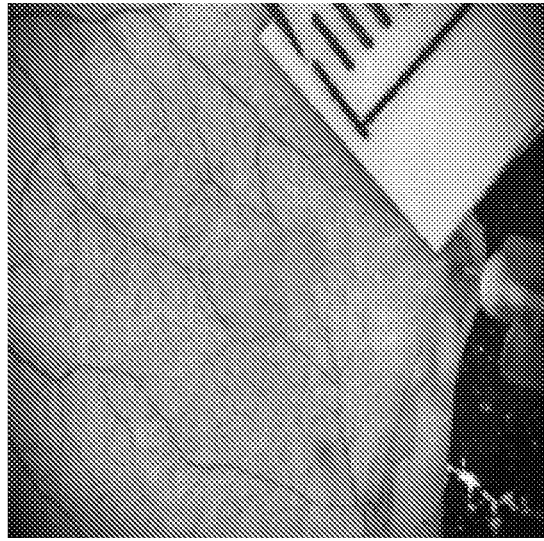

FIG. 2A

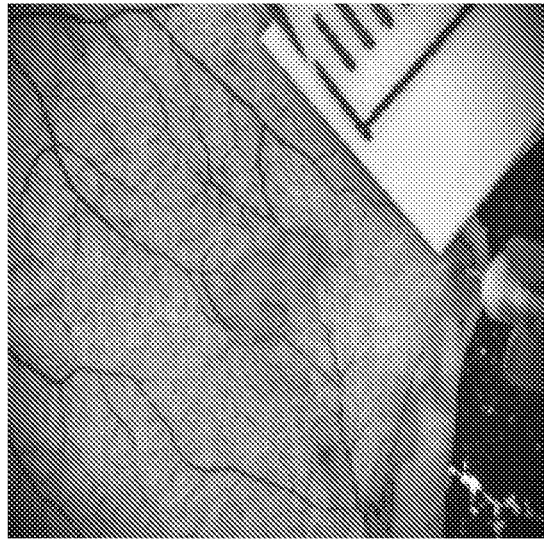

FIG. 2B

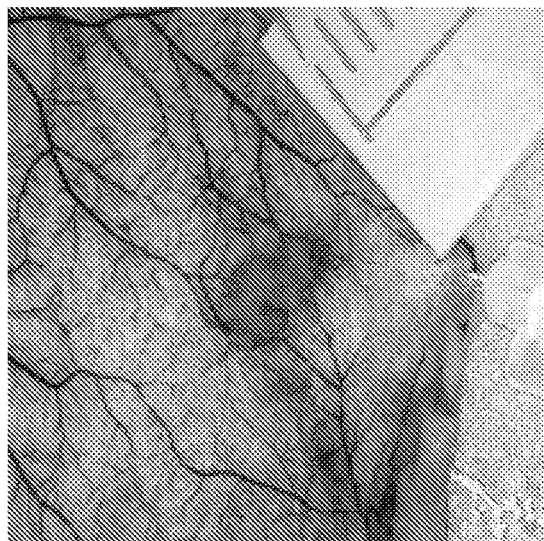
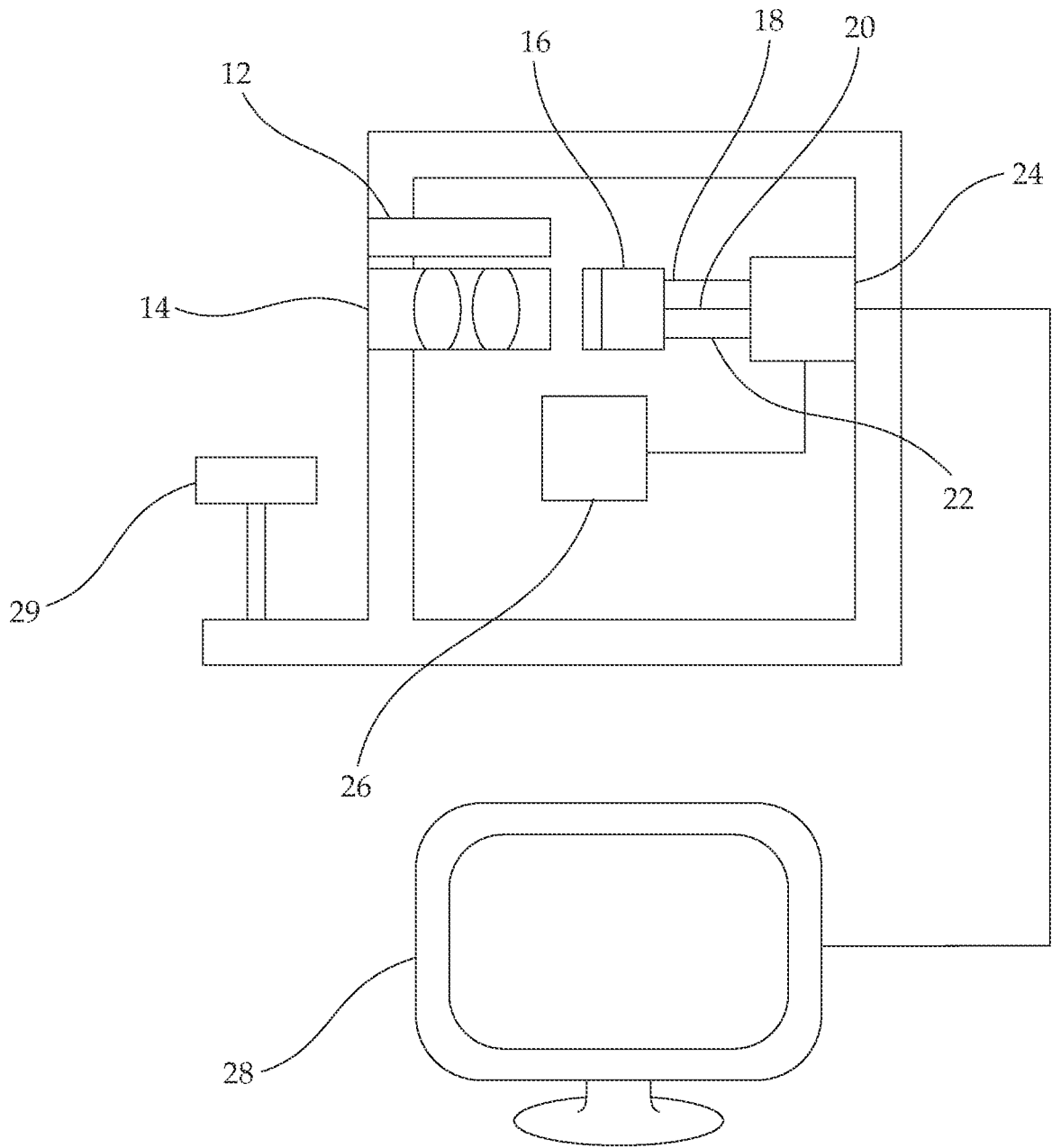

FIG. 2C



10

FIG. 3

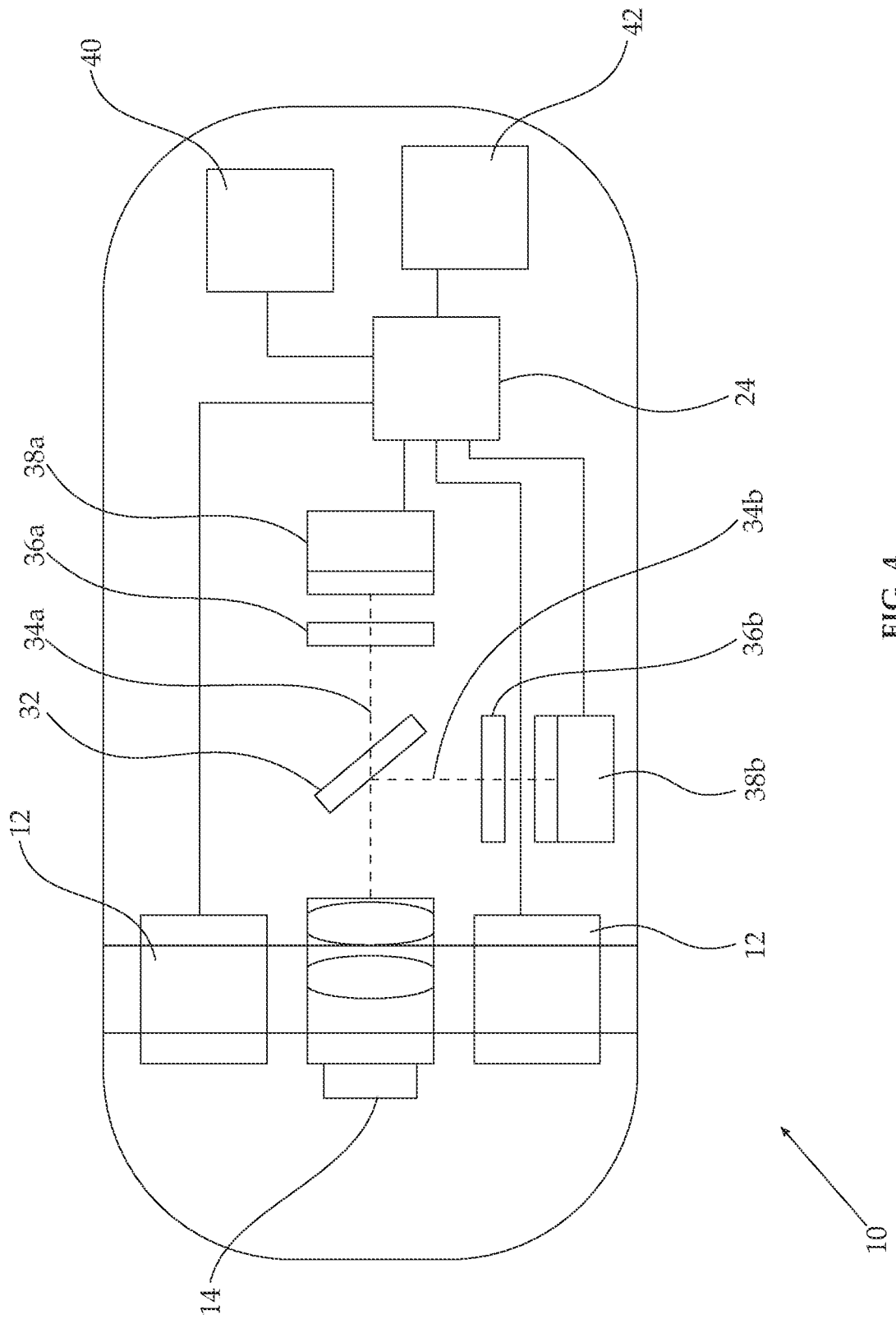

FIG. 4

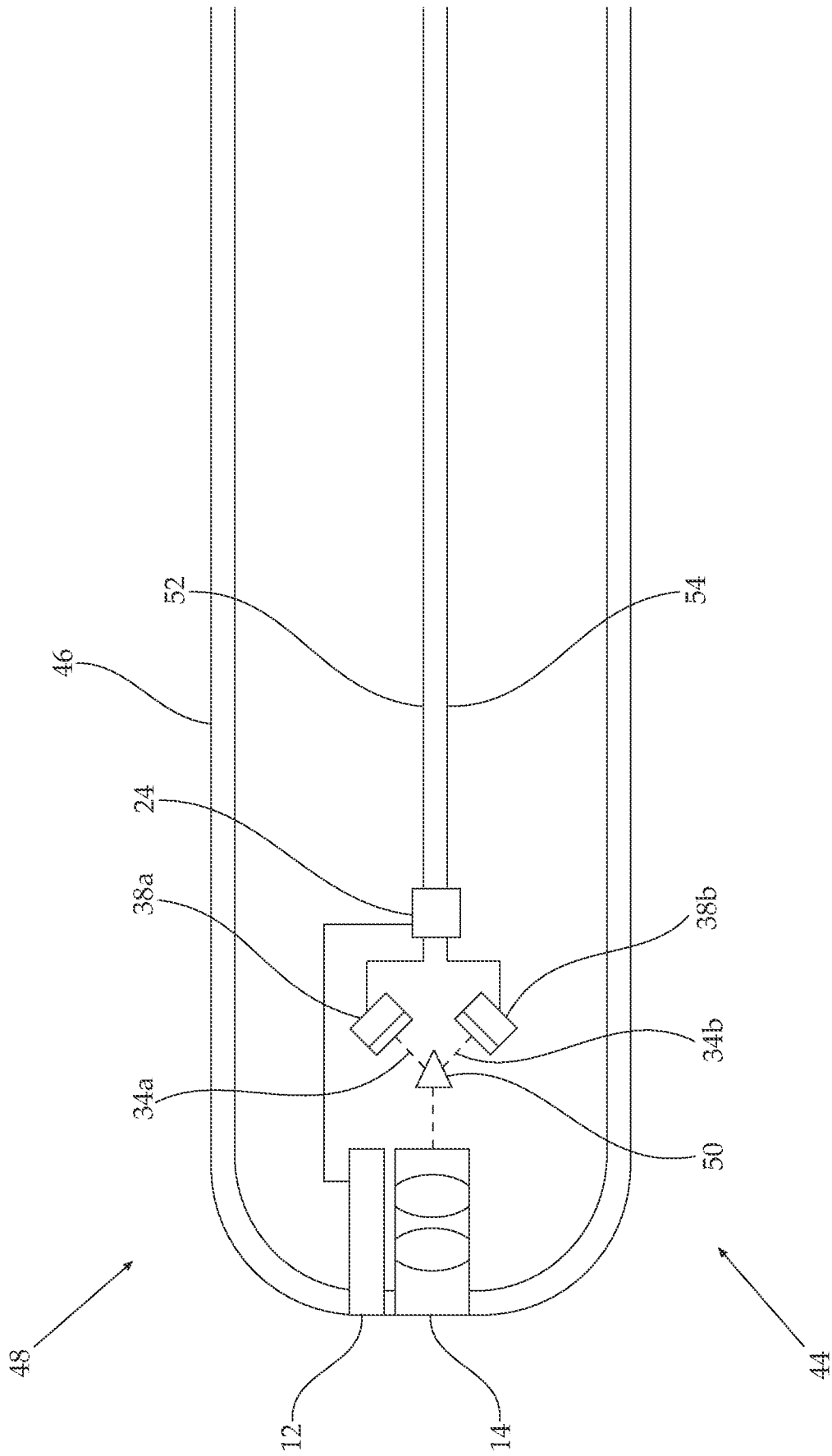

FIG. 5

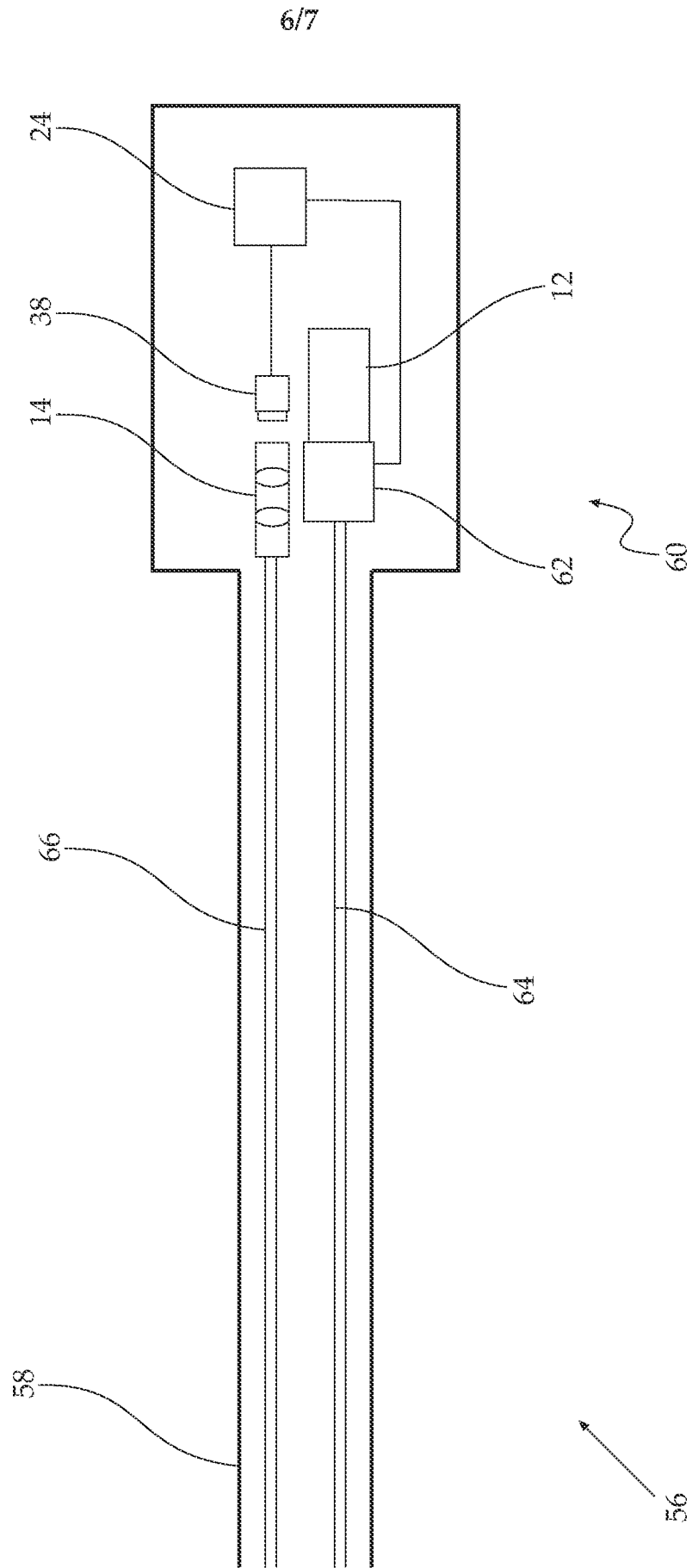

FIG. 6

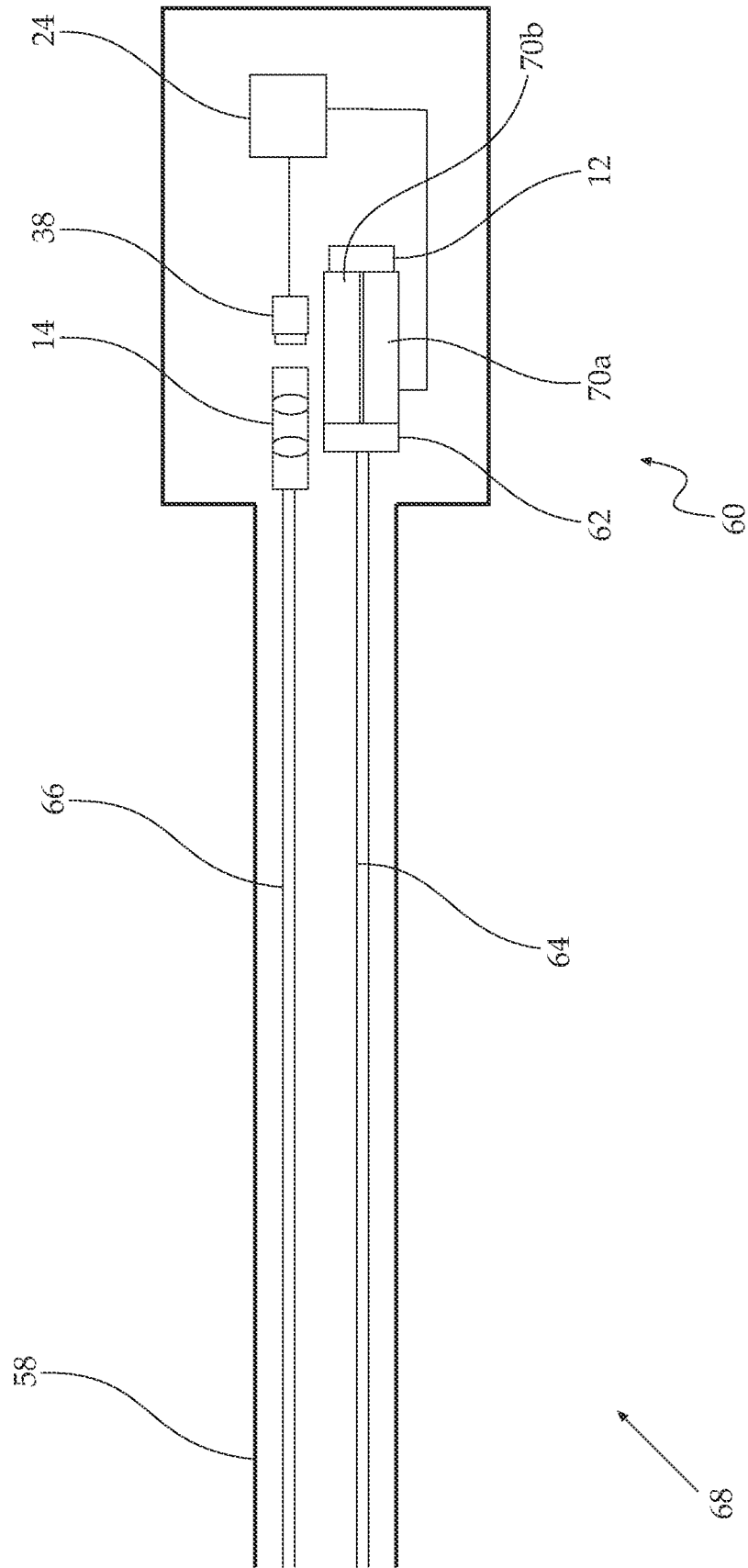

FIG. 7

INTERNATIONAL SEARCH REPORT

International application No PCT/IB2012/050563

A. CLASSIFICATION OF SUBJECT MATTER INV. A61B1/00 A61B3/00 A61B5/00 A61B1/04 ADD.				
According to International Patent Classification (IPC) or to both national classification and IPC				
B. FIELDS SEARCHED				
Minimum documentation searched (classification system followed by classification symbols) A61B G01N				
Documentation searched other than minimum documentation to the extent that such documents are included in the fields searched				
Electronic data base consulted during the international search (name of data base and, where practicable, search terms used) EPO-Internal, WPI Data				
C. DOCUMENTS CONSIDERED TO BE RELEVANT				
Category*	Citation of document, with indication, where appropriate, of the relevant passages	Relevant to claim No.		
X	US 2009/216085 A1 (YAMAZAKI KENJI [JP]) 27 August 2009 (2009-08-27) paragraphs [0035] - [0057], [0061] - [0074]; claims 1-2; figures 1-23 -----	1-30		
X	US 2001/007920 A1 (HAYASHI KATSUMI [JP]) 12 July 2001 (2001-07-12) paragraphs [0052] - [0059], [0090], [0123] - [0124]; claims 1-5; figures 1-12 -----	1,6,11, 12,18, 19,22-30		
X	US 2002/062061 A1 (KANEKO MAMORU [JP] ET AL) 23 May 2002 (2002-05-23) paragraph [0071]; figures 1,5,15 paragraph [0156] - paragraph [0169] paragraph [0172] - paragraph [0177]; figures 1-12,15 paragraphs [0108] - [0114] -----	1-30		
-/--				
<input checked="" type="checkbox"/> Further documents are listed in the continuation of Box C. <input checked="" type="checkbox"/> See patent family annex.				
* Special categories of cited documents : <table style="width: 100%; border: none;"> <tr> <td style="width: 50%; border: none; vertical-align: top;"> "A" document defining the general state of the art which is not considered to be of particular relevance "E" earlier application or patent but published on or after the international filing date "L" document which may throw doubts on priority claim(s) or which is cited to establish the publication date of another citation or other special reason (as specified) "O" document referring to an oral disclosure, use, exhibition or other means "P" document published prior to the international filing date but later than the priority date claimed </td> <td style="width: 50%; border: none; vertical-align: top;"> "T" later document published after the international filing date or priority date and not in conflict with the application but cited to understand the principle or theory underlying the invention "X" document of particular relevance; the claimed invention cannot be considered novel or cannot be considered to involve an inventive step when the document is taken alone "Y" document of particular relevance; the claimed invention cannot be considered to involve an inventive step when the document is combined with one or more other such documents, such combination being obvious to a person skilled in the art "&" document member of the same patent family </td> </tr> </table>			"A" document defining the general state of the art which is not considered to be of particular relevance "E" earlier application or patent but published on or after the international filing date "L" document which may throw doubts on priority claim(s) or which is cited to establish the publication date of another citation or other special reason (as specified) "O" document referring to an oral disclosure, use, exhibition or other means "P" document published prior to the international filing date but later than the priority date claimed	"T" later document published after the international filing date or priority date and not in conflict with the application but cited to understand the principle or theory underlying the invention "X" document of particular relevance; the claimed invention cannot be considered novel or cannot be considered to involve an inventive step when the document is taken alone "Y" document of particular relevance; the claimed invention cannot be considered to involve an inventive step when the document is combined with one or more other such documents, such combination being obvious to a person skilled in the art "&" document member of the same patent family
"A" document defining the general state of the art which is not considered to be of particular relevance "E" earlier application or patent but published on or after the international filing date "L" document which may throw doubts on priority claim(s) or which is cited to establish the publication date of another citation or other special reason (as specified) "O" document referring to an oral disclosure, use, exhibition or other means "P" document published prior to the international filing date but later than the priority date claimed	"T" later document published after the international filing date or priority date and not in conflict with the application but cited to understand the principle or theory underlying the invention "X" document of particular relevance; the claimed invention cannot be considered novel or cannot be considered to involve an inventive step when the document is taken alone "Y" document of particular relevance; the claimed invention cannot be considered to involve an inventive step when the document is combined with one or more other such documents, such combination being obvious to a person skilled in the art "&" document member of the same patent family			
Date of the actual completion of the international search	Date of mailing of the international search report			
23 May 2012	30/05/2012			
Name and mailing address of the ISA/ European Patent Office, P.B. 5818 Patentlaan 2 NL - 2280 HV Rijswijk Tel. (+31-70) 340-2040, Fax: (+31-70) 340-3016	Authorized officer Apostol, Simona			

INTERNATIONAL SEARCH REPORT

International application No PCT/IB2012/050563

C(Continuation). DOCUMENTS CONSIDERED TO BE RELEVANT

Category*	Citation of document, with indication, where appropriate, of the relevant passages	Relevant to claim No.
X	US 6 276 798 B1 (GIL TAMIR [IL] ET AL) 21 August 2001 (2001-08-21) cited in the application column 43, line 55 - column 44, line 34 column 47, lines 1-30 column 23, line 40 - column 26, line 33 -----	1,18
X	US 2007/253033 A1 (JOHANSEN BRIAN [US] ET AL) 1 November 2007 (2007-11-01) paragraphs [0026], [0055] - [0064]; claims 1-12; figures 1-9 -----	1,18
X,P	EP 2 328 339 A2 (FUJIFILM CORP [JP]) 1 June 2011 (2011-06-01) paragraphs [0055] - [0072]; claims 1-9; figures 1-9 -----	1,9,11, 18-20,30

INTERNATIONAL SEARCH REPORT

International application No.
PCT/IB2012/050563

Box No. II Observations where certain claims were found unsearchable (Continuation of item 2 of first sheet)

This international search report has not been established in respect of certain claims under Article 17(2)(a) for the following reasons:

1. Claims Nos.: **1-17(partially)**
because they relate to subject matter not required to be searched by this Authority, namely:
see FURTHER INFORMATION sheet PCT/ISA/210
2. Claims Nos.:
because they relate to parts of the international application that do not comply with the prescribed requirements to such an extent that no meaningful international search can be carried out, specifically:
3. Claims Nos.:
because they are dependent claims and are not drafted in accordance with the second and third sentences of Rule 6.4(a).

Box No. III Observations where unity of invention is lacking (Continuation of item 3 of first sheet)

This International Searching Authority found multiple inventions in this international application, as follows:

1. As all required additional search fees were timely paid by the applicant, this international search report covers all searchable claims.
2. As all searchable claims could be searched without effort justifying an additional fees, this Authority did not invite payment of additional fees.
3. As only some of the required additional search fees were timely paid by the applicant, this international search report covers only those claims for which fees were paid, specifically claims Nos.:
4. No required additional search fees were timely paid by the applicant. Consequently, this international search report is restricted to the invention first mentioned in the claims; it is covered by claims Nos.:

Remark on Protest

- The additional search fees were accompanied by the applicant's protest and, where applicable, the payment of a protest fee.
- The additional search fees were accompanied by the applicant's protest but the applicable protest fee was not paid within the time limit specified in the invitation.
- No protest accompanied the payment of additional search fees.

FURTHER INFORMATION CONTINUED FROM PCT/ISA/ 210

Continuation of Box II.1

Claims Nos.: 1-17(partially)

1 Claims 1-17 relate to methods of generating an image of biological tissue, the biological tissue including, as defined in claim 17, gastrointestinal mucose, oral mucosa, gynecological tract surface or respiratory tract surface i.a., imaging of which tissues requires performing an endoscopic procedure (see claim 30, Fig.5-7). The method seems to be partially oriented to clinical applications in the field of medical imaging diagnostic in surgical procedures, as resulted from the description (page 1). 2 This step of imaging inner organs, impling the use of an endoscopic device to be inserted into the body of a living person) is considered a substantial intervention performed by specialized surgeon and involving a substantial health risk, by means of which the method is considered to be a method for treatment of a human or an animal body by surgery according to the Rule 39.1(iv) PCT. 3 Search has been restricted to non-surgical imaging of external tissues.

INTERNATIONAL SEARCH REPORT

Information on patent family members

International application No PCT/IB2012/050563

Patent document cited in search report	Publication date	Patent family member(s)	Publication date
US 2009216085	A1	27-08-2009	EP 2095758 A1 02-09-2009 JP 2009201685 A 10-09-2009 US 2009216085 A1 27-08-2009

US 2001007920	A1	12-07-2001	JP 2001157658 A 12-06-2001 US 2001007920 A1 12-07-2001

US 2002062061	A1	23-05-2002	NONE

US 6276798	B1	21-08-2001	NONE

US 2007253033	A1	01-11-2007	CN 101536483 A 16-09-2009 JP 2009535705 A 01-10-2009 KR 20080113093 A 26-12-2008 TW 200816784 A 01-04-2008 US 2007253033 A1 01-11-2007 WO 2007127420 A2 08-11-2007

EP 2328339	A2	01-06-2011	EP 2328339 A2 01-06-2011 JP 2011098088 A 19-05-2011 US 2011112362 A1 12-05-2011

专利名称(译)	适用于对含血组织成像的方法和装置		
公开(公告)号	EP2672877A1	公开(公告)日	2013-12-18
申请号	EP2012705442	申请日	2012-02-08
[标]申请(专利权)人(译)	特尔哈肖梅尔医学研究基础设施和服务有限公司 特拉维夫大学拉莫特有限公司		
申请(专利权)人(译)	TEL HASHOMER医学研究基础设施和服务有限公司. 拉莫特在特拉维夫大学. , LTD.		
当前申请(专利权)人(译)	TEL HASHOMER医学研究基础设施和服务有限公司. 拉莫特在特拉维夫大学. , LTD.		
[标]发明人	KOSTENICH GENADY ORENSTEIN ARIE BELKIN MICHAEL		
发明人	KOSTENICH, GENADY ORENSTEIN, ARIE BELKIN, MICHAEL		
IPC分类号	A61B1/00 A61B3/00 A61B5/00 A61B1/04		
CPC分类号	A61B1/041 A61B3/12 A61B5/0075 A61B5/0077 A61B5/0084 A61B5/489 F04C2270/041 G06T5/50 G06T7/0012 A61B3/1241 A61B5/0261		
优先权	2011002209 2011-02-09 GB		
外部链接	Espacenet		

摘要(译)

公开了用于对含血组织进行成像的方法和装置，例如用于血管造影，尤其是视网膜血管造影，其中通过将某个波长范围获取的图像的像素划分为在不同波长范围获取的图像的对应像素来生成图像。。在一些实施例中，第一波长范围主要包括波长在约400nm和约620nm之间的光，第二波长范围包括主要包括波长在约620nm和约800nm之间的光。