

(19) World Intellectual Property Organization
International Bureau



(43) International Publication Date
10 December 2009 (10.12.2009)

PCT

(10) International Publication Number
WO 2009/149203 A1

(51) International Patent Classification:

G01N 33/569 (2006.01) A61L 15/00 (2006.01)
G01N 33/68 (2006.01) A61M 1/00 (2006.01)
C12Q 1/66 (2006.01)

(21) International Application Number:

PCT/US2009/046160

(22) International Filing Date:

3 June 2009 (03.06.2009)

(25) Filing Language:

English

(26) Publication Language:

English

(30) Priority Data:

61/058,819 4 June 2008 (04.06.2008) US
61/118,161 26 November 2008 (26.11.2008) US

(71) Applicant (for all designated States except US): **KCI LICENSING, INC.** [US/US]; Legal Department- Intellectual Property, P.o. Box 659508, San Antonio, TX 78265-9508 (US).

(72) Inventors; and

(75) Inventors/Applicants (for US only): **HUTCHINSON, George** [US/US]; 7011 Washita Way, San Antonio, TX 78256 (US). **KILPADI, Deepak, V.** [US/US]; 6527 Jade Meadow, San Antonio, TX 78249 (US). **PRICE, Nancy** [US/US]; 331 Adams Street, San Antonio, TX 78210 (US). **MCNULTY, Amy** [CA/US]; 4611 Rader Pass, San Antonio, TX 78247 (US).

(74) Agents: **WELCH, Gerald, T.** et al.; Sonnenschein, Nath & Rosenthal Llp, P.o. Box 061080, Wacker Drive Station, Sears Tower, Chicago, IL 60606 (US).

(81) Designated States (unless otherwise indicated, for every kind of national protection available): AE, AG, AL, AM, AO, AT, AU, AZ, BA, BB, BG, BH, BR, BW, BY, BZ, CA, CH, CL, CN, CO, CR, CU, CZ, DE, DK, DM, DO, DZ, EC, EE, EG, ES, FI, GB, GD, GE, GH, GM, GT, HN, HR, HU, ID, IL, IN, IS, JP, KE, KG, KM, KN, KP, KR, KZ, LA, LC, LK, LR, LS, LT, LU, LY, MA, MD, ME, MG, MK, MN, MW, MX, MY, MZ, NA, NG, NI, NO, NZ, OM, PG, PH, PL, PT, RO, RS, RU, SC, SD, SE, SG, SK, SL, SM, ST, SV, SY, TJ, TM, TN, TR, TT, TZ, UA, UG, US, UZ, VC, VN, ZA, ZM, ZW.

(84) Designated States (unless otherwise indicated, for every kind of regional protection available): ARIPO (BW, GH, GM, KE, LS, MW, MZ, NA, SD, SL, SZ, TZ, UG, ZM, ZW), Eurasian (AM, AZ, BY, KG, KZ, MD, RU, TJ, TM), European (AT, BE, BG, CH, CY, CZ, DE, DK, EE, ES, FI, FR, GB, GR, HR, HU, IE, IS, IT, LT, LU, LV, MC, MK, MT, NL, NO, PL, PT, RO, SE, SI, SK, TR), OAPI (BF, BJ, CF, CG, CI, CM, GA, GN, GQ, GW, ML, MR, NE, SN, TD, TG).

Published:

- with international search report (Art. 21(3))
- before the expiration of the time limit for amending the claims and to be republished in the event of receipt of amendments (Rule 48.2(h))

(54) Title: DETECTING INFECTION IN REDUCED PRESSURE WOUND TREATMENT

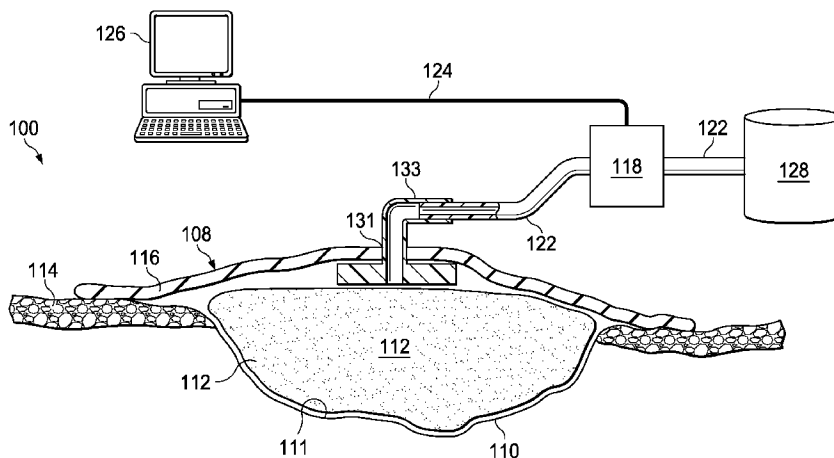

FIG. 1

(57) Abstract: Provided is a method of detecting infection in a wound caused by an infecting organism at a wound site. Also provided is a system for detecting an infection in a wound at a wound site. Additionally, a porous pad comprising luciferase is provided.

WO 2009/149203 A1

TITLE OF THE INVENTION**DETECTING INFECTION IN REDUCED PRESSURE WOUND TREATMENT**

5

CROSS-REFERENCE TO RELATED APPLICATIONS

[0001] This application claims the benefit of U.S. Provisional Application No. 61/058,819, filed June 4, 2008, and U.S. Provisional Application NO. 61/118,161, filed November 26, 2008, both of which are incorporated by reference.

10

BACKGROUND**1. Field of the Invention**

[0002] The present invention relates generally to tissue treatment systems and in particular to methods and compositions for detecting infection in a wound.

2. Description of Related Art

15

[0003] Clinical studies and practice have shown that a system for providing a reduced pressure in proximity to a tissue site augments and accelerates the growth of new tissue at the tissue site. The applications of this phenomenon are numerous, but application of reduced pressure has been particularly successful in treating wounds. This treatment (frequently referred to in the medical community as “negative pressure wound therapy,” “reduced pressure therapy,” or “vacuum therapy”) provides a number of benefits, including faster healing and increased formulation of granulation tissue. Typically, reduced pressure is applied to tissue through a porous pad or other manifold device. The porous pad contains cells or pores that are capable of distributing reduced pressure to the tissue and channeling fluids that are drawn from the tissue. The porous pad often is incorporated into a dressing having other components that facilitate treatment.

20

25

30

[0004] One difficulty associated with the use of such systems is detecting the presence or type of infection present in the wound without disturbing the airtight dressing covering the wound. Numerous methods have been developed relating to the detection of microorganisms. Various forms of those methods include the use of spectrometers, chromatographs, and other electronic sensors for detecting the presence of microorganisms. Exemplary U.S. patents include Lewis, et al. U.S. Pat. No. 6,017,440 issued Jan. 25, 2000; Chutjian, et al. U.S. Pat. No. 6,188,067 issued Feb. 13, 2001; Hunter, et al. U.S. Pat. No. 5,811,255 issued Sep. 22,

1998; Overton, et al. U.S. Pat. No. 5,611,846 issued Mar. 18, 1997; and Yu U.S. Pat. No. 5,583,281 issued Dec. 10, 1996.

[0005] While such systems have been highly successful in the promotion of wound closure, healing many wounds previously thought untreatable, some difficulty remains.

5 Because the very nature of such systems require an atmospherically sealed wound site, it is difficult to detect the presence or concentration of contaminant microorganisms such as bacteria that may be present in the wound site, without removing the wound dressing. It has heretofore been necessary to disturb the wound site, and thereby interrupt the therapy, in order to test for the presence or concentration of bacterial infection. Furthermore, any disturbance to
10 the wound site may increase the possibility of infection to the wound site. Additionally, removal of the wound dressing may cause pain or discomfort to the patient.

[0006] Some progress has been made to circumvent these problems with the invention described in United States Patent Application Publication US2002/0143286, incorporated herein by reference. That application describes the use of sensing devices that optically sense
15 the presence of a bacterial agent or other form of infection in the wound fluid. Other methods to more specifically identify and quantify the infectious agent are desirable.

[0007] Accordingly, a primary object of the present invention is to provide a vacuum assisted wound closure device that utilizes a means for detecting the presence of an infection present at a wound site during utilization of an airtight dressing without disturbing the dressing
20 at the wound site.

[0008] A further object of the present invention is to provide a means for identifying the nature or specific type of infection present at a wound site during the utilization of an airtight dressing without disturbing the dressing at the wound site.

[0009] It is yet a further object of the present invention to provide a means for
25 detecting the concentration of an infecting agent present at a wound site during utilization of an airtight dressing without disturbing the dressing at the wound site.

SUMMARY

[0010] The problems presented by existing means for detection of infection in reduced pressure treatment are solved by the methods and apparatuses of the illustrative embodiments described herein. In one embodiment, a method of detecting infection in a wound caused by an infecting organism at a wound site is provided that includes applying a reduced pressure to the wound site, withdrawing fluid from the wound site in response to the reduced pressure, collecting the fluid withdrawn from the wound site, and assaying the fluid collected from the wound site for a product of the infection or a component of the infecting organism, whereby the presence of the product or the component indicates the presence of an infection in the wound.

[0011] In an additional embodiment, a system for detecting an infection in a wound at a wound site is provided that includes a source of reduced pressure, a porous pad adapted to deliver the reduced pressure to the wound site, a drape adapted to provide a substantially airtight cover over the pad and the wound site, a conduit fluidly connecting the porous pad to the source of reduced pressure whereby fluid is withdrawn from the wound site in response to the reduced pressure, and a device for analyzing the fluid withdrawn from the wound site to identify a product of the infection or a component of an infecting organism, whereby the presence of the product of the component indicates the presence of an infection in the wound.

[0012] In a further embodiment, a porous pad adapted for distributing reduced pressure to a wound site is provided that includes luciferase.

[0013] Other objects, features, and advantages of the illustrative embodiments will become apparent with reference to the drawings and detailed description that follow.

BRIEF DESCRIPTION OF THE DRAWINGS

[0014] FIG. 1 is a diagram, shown in partial cross-section, of an illustrative embodiment of a reduced-pressure treatment system for detecting infection.

5 [0015] FIG. 2 is a diagram, shown in partial cross-section, of an illustrative embodiment of a reduced-pressure treatment system for detecting infection in which the reduced-pressure source includes a compartment for receiving a chip.

[0016] FIG. 3 is a diagram, shown in partial cross-section, of an illustrative embodiment of a reduced-pressure treatment system having a pad that contains a substance.

10

DETAILED DESCRIPTION

[0017] In the following detailed description of the illustrative embodiments, reference is made to the accompanying drawings that form a part hereof. These embodiments are described in sufficient detail to enable those skilled in the art to practice the invention, and it is understood that other embodiments may be utilized and that logical structural, mechanical, 15 electrical, and chemical changes may be made without departing from the spirit or scope of the invention. To avoid detail not necessary to enable those skilled in the art to practice the embodiments described herein, the description may omit certain information known to those skilled in the art. The following detailed description is, therefore, not to be taken in a limiting sense, and the scope of the illustrative embodiments are defined only by the appended claims.

20 [0018] Referring to FIG. 1, an illustrative embodiment of a reduced-pressure treatment system 100 provides reduced-pressure treatment to a tissue site 110, which may include a wound 111, and detects infections in the tissue site 110. The reduced-pressure treatment system 100 includes a reduced-pressure source 128, fluidly connected to a conduit 122, that delivers reduced pressure to the tissue site 110 via a dressing 108. The dressing 108 includes a 25 pad 112 that is disposed in the wound 111. A drape 116 is adhered to the patient's epidermis 114 and provides a fluid seal around the wound 111, allowing the maintenance of reduced pressure on the wound 111. Reduced pressure causes fluid, such as exudate, from the wound 111 to be drawn to a device 118 for analyzing the withdrawn fluid or extract thereof for a product of an infection or a component of an infecting organism or group of organisms.

30 [0019] The wound 111 may be an injury or defect located on or within any tissue site 110, including but not limited to, bone tissue, adipose tissue, muscle tissue, subcutaneous tissue, neural tissue, dermal tissue, vascular tissue, connective tissue, cartilage, tendons or

ligaments. The wound 111 may also be any tissue that is not necessarily injured or defected, but instead is an area in which it is desired to add or promote growth of additional tissue.

[0020] As used herein, an “infecting organism” is a microorganism (bacteria, fungi, protists, archaea, virus) that can cause wound infection. Non-limiting examples include
5 *Staphylococcus aureus*, *Streptococcus pyrogenes*, *Escherichia coli*, *Pseudomonas aeruginosa*,
Proteus mirabilis, *Klebsiella pneumoniae*, *Candida albicans* and *Bacteroides fragilis*. This
includes (a) specific biotypes of a particular species or genus that has a particular characteristic
or makes a particular product, where the characteristic or product can be detected by testing,
e.g., *S. aureus* producing toxic shock syndrome toxin-1 (TSST-1); coagulase-negative
10 staphylococci, or Group D streptococci; and (b) a group that has more than one species, e.g.,
Gram negative bacteria, *Corynebacterium spp.*, Enterococci, *Enterobacter spp.*, *Streptococcus*
spp. In some embodiments, the infecting organism or group of organisms is a bacterium.

[0021] As used herein, a “product of an infection” is a specifically identifiable
compound produced by either the host (*i.e.*, patient) or the infecting organism during an
15 infection. The host product might also be made when not infected, but for such a product to
be useful in the present methods, it should be produced in higher quantities in the fluid drawn
from the wound during infection than fluid drawn from an uninfected wound. Nonlimiting
examples of products of an infection include adenosine-5'-triphosphate (ATP) (made by
bacteria) and certain cytokines, fibronectin fragments, neutrophil proteases, and macrophage
20 protease (made by the host). A specifically identifiable compound is a compound that can be
identified individually by its chemical composition or reactivity to a particular reagent such as
an antibody or a nucleic acid probe of a particular sequence.

[0022] The drape 116 of the dressing 108 may be any material that provides a fluid
seal. The drape 116 may, for example, be an impermeable or semi-permeable, elastomeric
25 material. “Elastomeric” means having the properties of an elastomer. It generally refers to a
polymeric material that has rubber-like properties. More specifically, most elastomers have
elongation rates greater than 100% and a significant amount of resilience. The resilience of a
material refers to the material’s ability to recover from an elastic deformation. Examples of
elastomers may include, but are not limited to, natural rubbers, polyisoprene, styrene
30 butadiene rubber, chloroprene rubber, polybutadiene, nitrile rubber, butyl rubber, ethylene
propylene rubber, ethylene propylene diene monomer, chlorosulfonated polyethylene,
polysulfide rubber, polyurethane, EVA film, co-polyester, and silicones. Specific examples of

drape 116 materials include a silicone drape, 3M Tegaderm® drape, acrylic drape such as one available from Avery Dennison, or an incise drape. The drape 116 can include an aperture 131 in which interface 133 is inserted. The interface 133 provides fluid communication between the conduit 122 and the sealed space formed by the drape 116.

5 **[0023]** The term “pad” as used herein generally refers to a substance or structure that is provided to assist in applying reduced pressure to, delivering fluids to, or removing fluids from a tissue site 110. The pad 112 typically includes a plurality of flow channels or pathways that distribute fluids provided to and removed from the tissue site 110 around the pad 112. In one illustrative embodiment, the flow channels or pathways are interconnected to improve
10 distribution of fluids provided or removed from the tissue site 110. The pad 112 may be a biocompatible material that is capable of being placed in contact with the tissue site 110 and distributing reduced pressure to the tissue site 110. Examples of pads 112 may include, for example, without limitation, devices that have structural elements arranged to form flow
15 liquids, gels, and foams that include, or cure to include, flow channels. The pad 112 may be porous and may be made from foam, gauze, felted mat, or any other material suited to a particular biological application. In one embodiment, the pad 112 is a porous foam and includes a plurality of interconnected cells or pores that act as flow channels. The porous
20 foam may be a polyurethane, open-cell, reticulated foam such as GranuFoam® material manufactured by Kinetic Concepts, Incorporated of San Antonio, Texas. Other embodiments might include “closed cells.” These closed-cell portions of the pad 112 may contain a plurality of cells, the majority of which are not fluidly connected to adjacent cells. The closed cells may be selectively disposed in the pad 112 to prevent transmission of fluids through
25 perimeter surfaces of the pad 112. In some situations, the pad 112 may also be used to distribute fluids such as medications, antibacterials, growth factors, and various solutions to the tissue site 110. Other layers may be included in or on the pad 112, such as absorptive materials, wicking materials, hydrophobic materials, and hydrophilic materials

[0024] In some embodiments, the pad 112 includes a compound that reacts with a component of an infecting organism or a product of the infection in the wound 111. As
30 discussed above, the product of the infection can be either from the host (*e.g.*, a compound such as a host protein produced in response to infection, for example a cytokine, a fibronectin fragment, a neutrophil protease, or a macrophage protease) or from the organism (*e.g.*, ATP).

In these embodiments, the product of the reaction between the compound and the component of the infecting organism or the product of the infection is drawn into the conduit 122 and detected by the device 118. The device 118 may then notify a data processing system 126, such as a computer, when the product of the reaction is detected via a communications
5 connection 124. The communications connection 124 includes both wire and wireless forms of communication. The data processing system 126 stores the data and may perform calculations to, *e.g.*, calculate the concentration of the measured component or product, or the extent of the infection.

[0025] In another embodiment, the device 118 has the reacting compound to detect the
10 component of an infecting organism or a product of the infection; in this embodiment, fluid from the wound 111 is pulled through the pad 112, and into the device 118 to bring the fluid into the presence of the compound. The device 118 may also have the means for measuring the results of the reaction (*e.g.*, charged coupled device [CCD] camera to measure the results from a microarray, chemistry chip or microfluidics device, or photodetector to measure light
15 from the luciferase reaction).

[0026] A common product of bacterial infection that may be detected in the illustrative embodiments is adenosine-5'-triphosphate (ATP). In these methods, ATP may be detected by any means known in the art. In some embodiments, ATP is detected using the following luciferase-luciferin reaction, in the presence of Mg^{+2} :

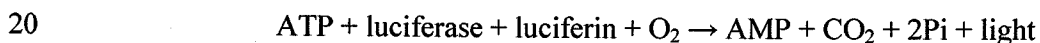

The light may be visualized, and optionally quantified, using, for example, a photodetector. In one embodiment, the device 118 is a photodetector.

[0027] Thus, in some embodiments, the ATP is detected by combining the fluid withdrawn from the wound 111 or an extract thereof with luciferase and luciferin, then
25 measuring the light produced in an ensuing reaction. If the light produced exceeds the light produced by a wound that is not infected, then the wound 111 is infected. In various embodiments, the ATP is quantified by measuring the emitted light, where an increasing amount of ATP in the withdrawn fluid or extract thereof indicates an infection of the wound 111 of increasing severity. See, *e.g.*, U.S. Patents 4,833,075; 5,756,303; and 5,916,802 and
30 European patent application 0025351A1 for examples of methods of quantifying ATP to determine the presence of bacteria in a liquid.

[0028] In other embodiments, the product of the infection is a host protein associated with an inflammatory response. Any such host protein may be detected by the device 118 in these embodiments. In some of these embodiments, the host protein is a cytokine, a fibronectin fragment, a neutrophil protease, or a macrophage protease. See, *e.g.*, PCT patent publication WO 2004/086043 and U.S. Patent Application Publication US 2005/0079542 A1.

[0029] The device 118 can also determine an infection in the wound fluid or extract by assaying for a component of an infecting organism or group of organisms. As used herein, a “component of an infecting organism” is a specifically identifiable piece of an organism capable of causing a wound infection. Nonlimiting examples of such components are lipopolysaccharide (LPS), lipoteichoic acid (LTA), antigens, and DNA having a particular sequence that is characteristic of a specific organism.

[0030] In certain embodiments where Gram negative bacteria is to be assayed, the withdrawn fluid or extract thereof is combined with a limulus amoebocyte lysate, which is sensitive for the lipopolysaccharide (LPS) of Gram negative bacteria. LPS can also be detected, *e.g.*, with antibodies by known immunoassays, including assays that measure endotoxin activity by the priming host neutrophil respiratory burst activity via complement opsonized LPS-IgM immune complexes, such as the Endotoxin Activity Assay™ (Hilmi *et al.*, J. Organ Dysfunction, advanced online publication, 23 March 2009).

[0031] In various embodiments where Gram positive bacteria is to be assayed, a component to be assayed is lipoteichoic acid (LTA), which is detected by any means known in the art. In some of these embodiments, the LTA is detected with an assay comprising combining the withdrawn fluid or extract thereof with an antibody that specifically binds to LTA, then determining whether the antibody has bound to LTA.

[0032] In some embodiments, the wound fluid or extract thereof is tested for at least one specific genus or species of organism capable of causing a wound infection, *e.g.*, *Streptococcus sp.*, or *Streptococcus pyrogenes*. Such tests are desirable when the organism is identified to determine an infection treatment that affects a narrow host range, *e.g.*, when an antibiotic is to be used that has a narrow host target range.

[0033] In some embodiments, assaying for a specific genus or species of organism capable of causing a wound infection involves the device 118 identifying, in an extract of the wound fluid, a nucleic acid sequence that is specific for an organism or group of organisms. In some of these methods, the withdrawn fluid is treated to release DNA or RNA from an

infecting organism; the DNA, or a cDNA reverse-transcribed from the RNA, is labeled with a detectable label and applied to at least one immobilized nucleic acid specific for the at least one specific organism or group of organisms; and the immobilized nucleic acid is evaluated to determine whether the detectable label is specifically bound thereto. Here, the specific
5 binding of the detectable label to the immobilized nucleic acid indicates that the wound 111 is infected with the specific organism or group of organisms. It is contemplated that microarrays or microfluidics chips can be used for these tests. See, *e.g.*, Affymetrix (2005) Application Notes, Microarray Applications in Infectious Disease, at www.affymetrix.com. In some aspects of these embodiments, the labeled DNA or cDNA is applied to a microarray
10 comprising at least five, ten, twenty, fifty or one hundred immobilized nucleic acids, each nucleic acid specific for a different organism or group of organisms capable of causing a wound infection.

[0034] In other embodiments, antibodies or aptamers are used to detect an antigen or aptamer binding site on the organism or group of organisms. In some of these embodiments,
15 the withdrawn fluid or extract thereof is combined with an antibody or aptamer specific for a genus or species of organism or organisms, and the antibody or aptamer is then evaluated to determine whether an antigen from the wound 111 is bound to the antibody or aptamer. Further, multiple antibodies or aptamers can be used to assay for multiple organisms. Thus, in some of these methods, the withdrawn fluid or extract thereof is combined with more than one
20 antibody or aptamer, each antibody or aptamer specific for a different genus or species of organism capable of causing a wound infection; and the more than one antibody or aptamer is then evaluated to determine whether any of the more than one antibody or aptamer is bound to an antigen or aptamer binding site from the wound.

[0035] Numerous assays are known in the art for determining whether an antibody or
25 aptamer is bound to an antigen or aptamer binding site. Examples include ELISA, western blot, and the assays described in U.S. Patent Application Publication US 2007/0292397 A1, incorporated herein by reference.

[0036] In one embodiment, the device 118 includes a compartment (not shown) for
30 placing a substrate (not shown) comprising bound antibodies such that the fluid flows onto the antibodies as the fluid is drawn from the wound 111. These methods are not limited to any particular substrate for the device 118. Examples include polystyrene microtiter plates,

nitrocellulose paper, and microchips. In further embodiments, the device comprises a limulus amebocyte lysate.

[0037] One method for detecting infection in the wound 111 includes subjecting the wound 111 to reduced pressure sufficient to withdraw fluid from the wound 111. The fluid
5 from the wound 111 may be collected in the device 118 or elsewhere, and the withdrawn fluid or an extract thereof may be assayed for a product of the infection or a component of the infecting organism or group of organisms. The presence of the product or component indicates infection in the wound 111. The illustrative embodiments can allow testing of the wound 111 for infection without removal of the dressing 108 for the wound, and detect
10 specific organisms or groups of organisms.

[0038] In an alternative embodiment, the system 100 further comprises a reservoir (not shown) adapted for collection of the wound fluids. Such a reservoir may be used to collect fluids that are tested using a separate component of the system 100, such as the device 118. In another example, the device 118 or the reduced-pressure source 128 may have such a
15 reservoir.

[0039] FIG. 2 shows an illustrative embodiment of a reduced-pressure treatment system 200 that includes a reduced-pressure source 228 that comprises a port 230 for a chip 235. The chip 235 may be a microfluidics or microarray or chemistry chip, as well as a detector (*e.g.*, a CCD camera). The chip 235 may be used for detecting specific antigens or
20 nucleic acids characteristic of an organism or group of organisms. The wound fluid is drawn through the conduit 122 to interact with the chip 235 in the port 230. The outlet 237 of the conduit 122 delivers the wound fluid to the chip 235 so that the chip 235 can interact with the wound fluid. The reduced-pressure source 228 can be configured to analyze the microarray or microfluidic data. In some embodiments using microarrays, the labeled DNA or cDNA is
25 applied to a microarray comprising at least five, ten, twenty, fifty or one hundred immobilized nucleic acids, each nucleic acid specific for a different organism or group of organisms capable of causing a wound infection. Excess fluid is then removed through waste conduit 236.

[0040] Optionally, the system 200 may also have the device 118 and the
30 communications cable 224. The device 118 or separate data processing system (not shown) can be configured to analyze the microarray or microfluidic data. In the system 200, two

measurements can be made on the wound fluid - from the device 118 and from the chip 235 in the port 230.

[0041] FIG. 3 is an illustrative embodiment of a reduced-pressure treatment system 300 that includes a pad 312 impregnated with luciferase and luciferin 334. In some 5 embodiments, the luciferase is covalently bound to the pad 312, *e.g.*, as described in U.S. Patent No. 4,833,075. The reduced-pressure source 128 draws ATP from an infection in the wound 111 into the pad 312, and the ATP reacts with the luciferase and luciferin 334 to generate light. The light generated by the ATP/luciferase/luciferin reaction is detected by the device 318, which comprises a photodetector, and the light measurement is optionally 10 transmitted to the data processing system 126 via the communications connection 124. The data processing system 126 can then record the light measurements. In this manner, the detection of light by the device 318 indicates the presence of ATP in the wound 111.

[0042] The device 318 is shown to be integrated with the drape 116. However, the device 318 may be located anywhere in the system 300 at which light from the 15 ATP/luciferase/luciferin reaction can be detected.

[0043] In some embodiments, the system 300 further comprises a supply line 345 fluidly connected to the pad 312 for the introduction of luciferase and/or luciferin 334 from a reservoir 347. The supply line 345 may also be used to provide an infection-controlling compound to the wound 111, in which case the reservoir 347 includes such a compound. 20

[0044] It should be apparent from the foregoing that an invention having significant advantages has been provided. While the invention is shown in only a few of its forms, it is not just limited but is susceptible to various changes and modifications without departing from the spirit thereof.

[0045] All references cited in this specification are hereby incorporated by reference. 25 The discussion of the references herein is intended merely to summarize the assertions made by the authors and no admission is made that any reference constitutes prior art. Applicants reserve the right to challenge the accuracy and pertinence of the cited references.

CLAIMS

We claim:

- 5 Claim 1. A method of detecting infection in a wound caused by an infecting organism at a wound site, the method comprising:
- applying a reduced pressure to the wound site;
 - withdrawing fluid from the wound site in response to the reduced pressure;
 - collecting the fluid withdrawn from the wound site; and
 - 10 assaying the fluid collected from the wound site for a product of the infection or a component of the infecting organism;
- whereby the presence of the product or the component indicates the presence of an infection in the wound.
- 15 Claim 2. The method of claim 1, wherein the infecting organism is a bacterium.
- Claim 3. The method of claim 1, wherein the wound comprises a tissue selected from the group consisting of dermal tissue, bone tissue, cartilage, tendon, ligament, muscle, nerve tissue, subcutaneous tissue, and adipose tissue.
- 20 Claim 4. The method of claim 1, wherein the fluid withdrawn is assayed for the product of the infection.
- Claim 5. The method of claim 4, wherein the product of the infection is adenosine-5'-triphosphate (ATP).
- 25 Claim 6. The method of claim 5, wherein the ATP is detected by combining the fluid withdrawn with luciferase and luciferin, then measuring the light produced, wherein if light is produced above levels produced by a fluid from a wound that is not infected, then the wound
- 30 is infected.

Claim 7. The method of claim 5, wherein the ATP is quantified, wherein an increasing amount of ATP in the fluid withdrawn indicates an infection of the wound of increasing severity.

- 5 Claim 8. The method of claim 4, wherein the product of the infection is a host protein associated with an inflammatory response.

Claim 9. The method of claim 8, wherein the host protein is a cytokine, a fibronectin fragment, a neutrophil protease, or a macrophage protease.

10

Claim 10. The method of claim 1, wherein the fluid withdrawn is assayed for the component of an infecting organism.

- 15 Claim 11. The method of claim 10, wherein the component of the infecting organism assayed is lipopolysaccharide (LPS) of Gram negative bacteria, which is detected with an assay comprising combining the fluid withdrawn with a limulus amoebocyte lysate or by an assay that primes host neutrophil respiratory burst activity via complement opsonized LPS-IgM immune complexes.

- 20 Claim 12. The method of claim 10, wherein the component of the infecting organism assayed is lipoteichoic acid (LTA) of Gram positive bacteria, which is detected with an assay comprising combining the fluid withdrawn with an antibody that specifically binds to LTA, then determining whether the antibody has bound to LTA.

- 25 Claim 13. The method of claim 10, wherein the fluid withdrawn is assayed for a component of at least one specific genus or species of organism capable of causing a wound infection.

- Claim 14. The method of claim 13, wherein
the fluid withdrawn is treated to release DNA or RNA from the infecting organism;
30 the DNA, or a cDNA reverse transcribed from the RNA, is labeled with a detectable label and applied to at least one immobilized nucleic acid specific for the at least one specific organism; and

the immobilized nucleic acid is evaluated to determine whether the detectable label is specifically bound thereto,

wherein the specific binding of the detectable label to the immobilized nucleic acid indicates that the wound is infected with the genus or species of organism.

5

Claim 15. The method of claim 14, wherein the labeled DNA or cDNA is applied to a microarray comprising at least twenty immobilized nucleic acids, each nucleic acid specific for a different genus or species of organism capable of causing a wound infection.

10 Claim 16. The method of claim 13, wherein

the fluid withdrawn is combined with an antibody or aptamer specific for the at least one specific genus or species of organism; and

the antibody or aptamer is evaluated to determine whether the antibody or aptamer is bound to an antigen or aptamer binding site from the wound.

15

Claim 17. The method of claim 16, wherein

the fluid withdrawn is combined with more than one antibody or aptamer, each antibody or aptamer specific for a different genus or species of organism capable of causing a wound infection; and

20

the more than one antibody or aptamer is then evaluated to determine whether any of the more than one antibody or aptamer is bound to an antigen or aptamer binding site from the wound.

25 Claim 18. The method of claim 1, wherein the reduced pressure is applied from an apparatus comprising:

a source of reduced pressure;

a porous pad adapted to deliver the reduced pressure to the wound site;

a drape adapted to provide a cover over the pad and the wound site; and

a conduit fluidly connecting the porous pad to the source of reduced pressure whereby

30

fluid is withdrawn from the wound site in response to the reduced pressure.

Claim 19. The method of claim 18, wherein the apparatus further comprises a reservoir adapted for collection of the fluid.

5 Claim 20. The method of claim 18, wherein the porous pad comprises luciferase and luciferin and the apparatus further comprises a photodetector capable of measuring light emitting from the porous pad.

10 Claim 21. The method of claim 20, wherein the luciferase is covalently bound to the porous pad.

Claim 22. The method of claim 20, wherein the apparatus further comprises a computer linked to the photodetector, wherein the computer is capable of recording the light measurements from the photodetector.

15 Claim 23. The method of claim 22, wherein the computer is further capable of determining whether the recorded light measurements indicate infection in the wound.

20 Claim 24. The method of claim 20, wherein the apparatus further comprises a supply line into the porous pad for the introduction of an infection-controlling compound to the wound.

Claim 25. A system for detecting an infection in a wound at a wound site, the system comprising:

- 25 a source of reduced pressure;
- a porous pad adapted to deliver the reduced pressure to the wound site;
- a drape adapted to provide a substantially airtight cover over the pad and the wound site;
- a conduit fluidly connecting the porous pad to the source of reduced pressure whereby fluid is withdrawn from the wound site in response to the reduced pressure; and
- 30 a device for analyzing the fluid withdrawn from the wound site to identify a product of the infection or a component of an infecting organism;
- whereby the presence of the product or the component indicates the presence of an infection in the wound.

Claim 26. The system of claim 25, wherein the device comprises a photodetector and the pad further comprises luciferase and luciferin.

5 Claim 27. The system of claim 26, wherein the luciferase is covalently bound to the pad.

Claim 28. The system of claim 29, wherein the device comprises a compartment for placing a substrate comprising bound antibodies such that the fluid flows onto the antibodies as the fluid is drawn from the wound.

10

Claim 29. The system of claim 29, wherein the device comprises a limulus amoebocyte lysate.

Claim 30. The system of claim 29, wherein the device comprises a microfluidics chip, a chemistry chip or a microarray.

15

Claim 31. The system of claim 30, wherein the microfluidics chip, chemistry chip or microarray is in the reduced pressure source.

20 Claim 32. The system of claim 30, further comprising a computer capable of recording results from the analysis.

Claim 33. A porous pad adapted for distributing reduced pressure to a wound site, wherein the pad comprises luciferase.

25 Claim 34. The porous pad of claim 33, wherein the luciferase is covalently bound to the pad.

Claim 35. The porous pad of claim 33, further comprising luciferin.

Claim 36. Use of the system of claim 25 for the treatment of a wound.

1/3

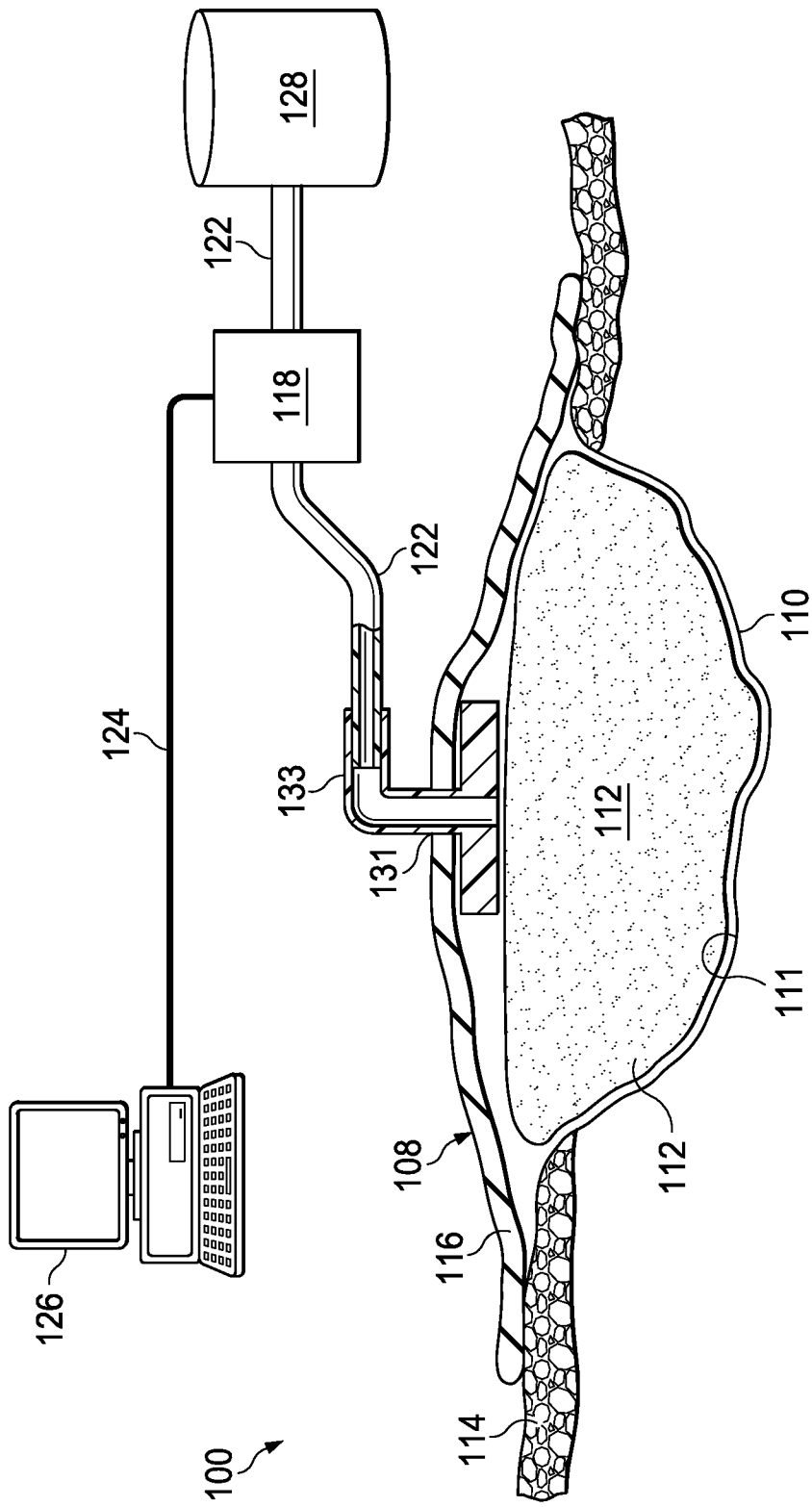

FIG. 1

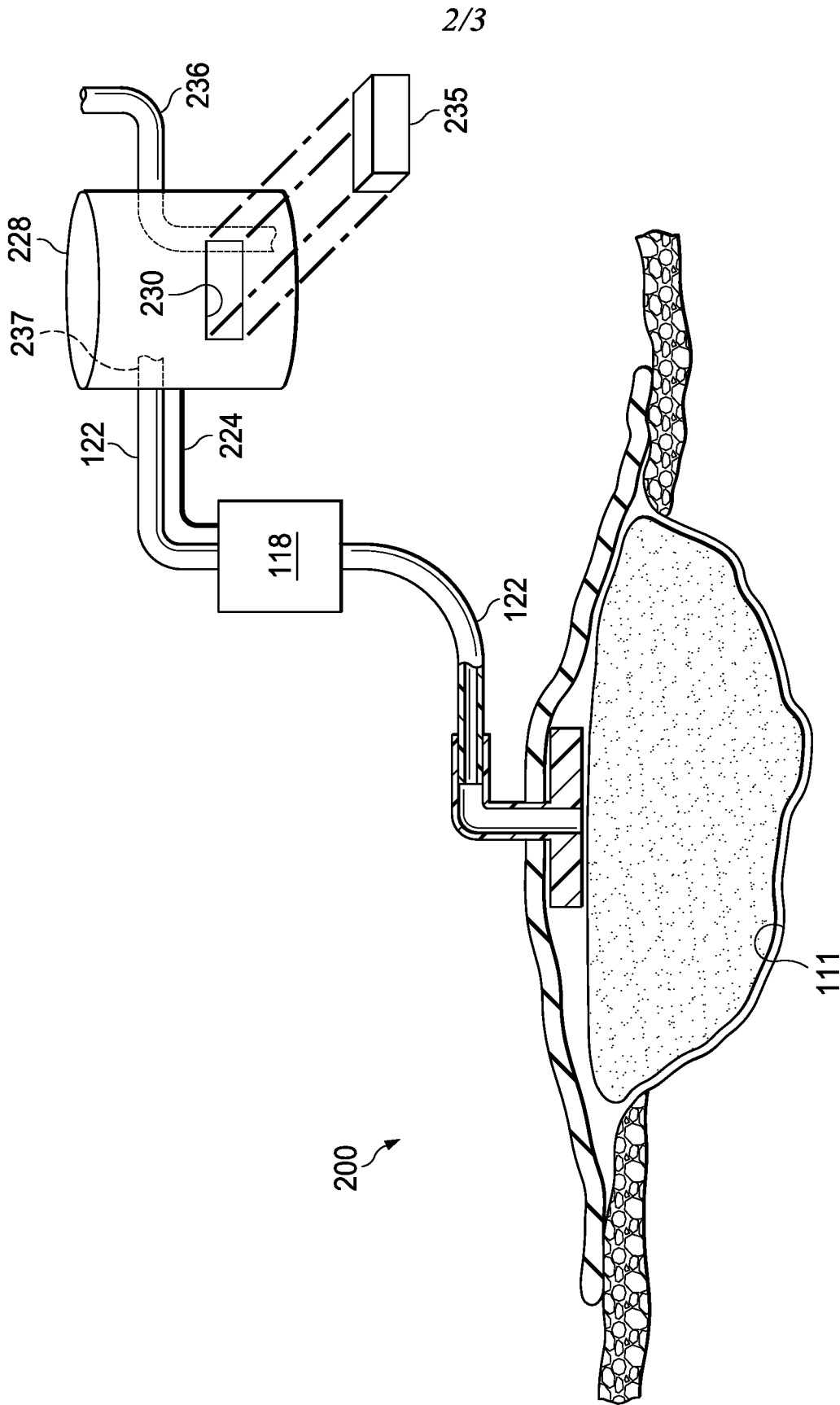

FIG. 2

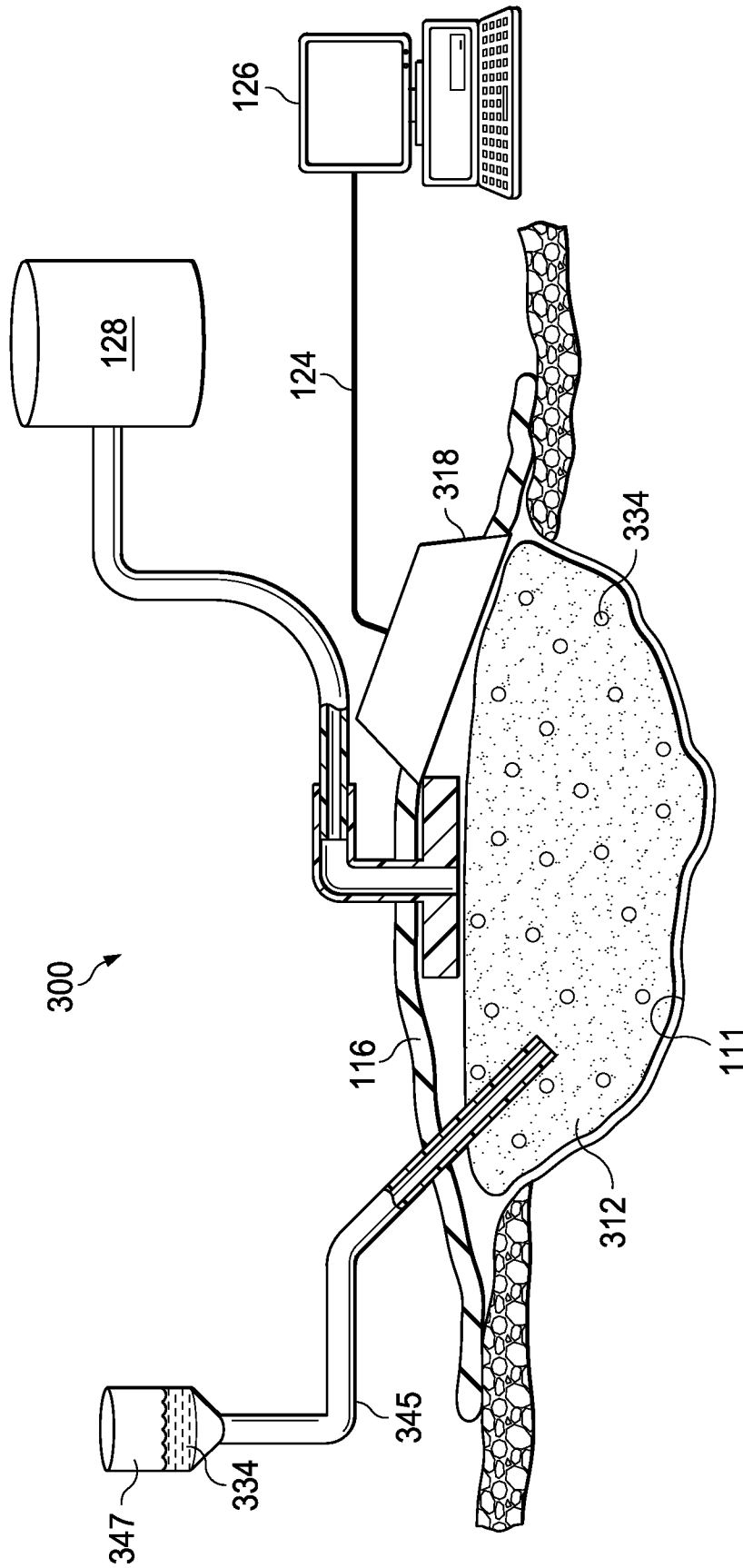

FIG. 3

INTERNATIONAL SEARCH REPORT

International application No
PCT/US2009/046160

A. CLASSIFICATION OF SUBJECT MATTER

INV. G01N33/569 G01N33/68 C12Q1/66 A61L15/00 A61M1/00

According to International Patent Classification (IPC) or to both national classification and IPC

B. FIELDS SEARCHED

Minimum documentation searched (classification system followed by classification symbols)

G01N C12Q A61L A61M

Documentation searched other than minimum documentation to the extent that such documents are included in the fields searched

Electronic data base consulted during the international search (name of data base and, where practical, search terms used)

EPO-Internal, WPI Data, EMBASE, BIOSIS

C. DOCUMENTS CONSIDERED TO BE RELEVANT

Category*	Citation of document, with indication, where appropriate, of the relevant passages	Relevant to claim No.
X	US 2002/143286 A1 (TUMEY DAVID [US]) 3 October 2002 (2002-10-03) paragraphs [0002], [0010] - [0018], [0024] - [0026] figures 1,2	1, 2, 25, 36
X	US 2003/050594 A1 (ZAMIEROWSKI DAVID S [US]) 13 March 2003 (2003-03-13) paragraphs [0013], [0017], [0073] - [0083] figures 15,16	1, 2, 25, 36
X	US 2003/040687 A1 (BOYNTON THOMAS A [US] ET AL BOYNTON THOMAS A [US] ET AL) 27 February 2003 (2003-02-27) paragraphs [0001], [0028], [0029] figure 1	1, 2, 25, 36
	----- -/--	

 Further documents are listed in the continuation of Box C. See patent family annex.

* Special categories of cited documents :

- *A* document defining the general state of the art which is not considered to be of particular relevance
- *E* earlier document but published on or after the international filing date
- *L* document which may throw doubts on priority claim(s) or which is cited to establish the publication date of another citation or other special reason (as specified)
- *O* document referring to an oral disclosure, use, exhibition or other means
- *P* document published prior to the international filing date but later than the priority date claimed

- *T* later document published after the international filing date or priority date and not in conflict with the application but cited to understand the principle or theory underlying the invention
- *X* document of particular relevance; the claimed invention cannot be considered novel or cannot be considered to involve an inventive step when the document is taken alone
- *Y* document of particular relevance; the claimed invention cannot be considered to involve an inventive step when the document is combined with one or more other such documents, such combination being obvious to a person skilled in the art.
- * & * document member of the same patent family

Date of the actual completion of the international search

31 August 2009

Date of mailing of the international search report

09/11/2009

Name and mailing address of the ISA/

European Patent Office, P.B. 5818 Patentlaan 2
NL - 2280 HV Rijswijk
Tel. (+31-70) 340-2040,
Fax: (+31-70) 340-3016

Authorized officer

Chrétien, Eva Maria

INTERNATIONAL SEARCH REPORT

International application No

PCT/US2009/046160

C(Continuation). DOCUMENTS CONSIDERED TO BE RELEVANT

Category*	Citation of document, with indication, where appropriate; of the relevant passages	Relevant to claim No.
X	GB 2 442 132 A (TYCO HEALTHCARE [US]) 26 March 2008 (2008-03-26) page 1, paragraph 3 page 7, paragraph 3 page 11, paragraph 1 figure 1 claims 1,4	1,2,25, 36
A	US 2007/292397 A1 (MCNULTY AMY K [US] ET AL) 20 December 2007 (2007-12-20) the whole document	1,2,25, 36
A	WO 2007/092909 A (EXPRESSIVE CONSTRUCTS INC [US]; SANDERS MITCHELL C [US]; RAKITIN ANDRE) 16 August 2007 (2007-08-16) the whole document	1,2,25, 36

INTERNATIONAL SEARCH REPORT

International application No.
PCT/US2009/046160

Box No. II Observations where certain claims were found unsearchable (Continuation of item 2 of first sheet)

This international search report has not been established in respect of certain claims under Article 17(2)(a) for the following reasons:

1. Claims Nos.:
because they relate to subject matter not required to be searched by this Authority, namely:

2. Claims Nos.:
because they relate to parts of the international application that do not comply with the prescribed requirements to such an extent that no meaningful international search can be carried out, specifically:

3. Claims Nos.:
because they are dependent claims and are not drafted in accordance with the second and third sentences of Rule 6.4(a).

Box No. III Observations where unity of invention is lacking (Continuation of item 3 of first sheet)

This International Searching Authority found multiple inventions in this international application, as follows:

see additional sheet

1. As all required additional search fees were timely paid by the applicant, this international search report covers allsearchable claims.

2. As all searchable claims could be searched without effort justifying an additional fees, this Authority did not invite payment of additional fees.

3. As only some of the required additional search fees were timely paid by the applicant, this international search report covers only those claims for which fees were paid, specifically claims Nos.:

4. No required additional search fees were timely paid by the applicant. Consequently, this international search report is restricted to the invention first mentioned in the claims; it is covered by claims Nos.:

1,25,36 (partially) , 2 (fully)

Remark on Protest

- The additional search fees were accompanied by the applicant's protest and, where applicable, the payment of a protest fee.
- The additional search fees were accompanied by the applicant's protest but the applicable protest fee was not paid within the time limit specified in the invitation.
- No protest accompanied the payment of additional search fees.

FURTHER INFORMATION CONTINUED FROM PCT/ISA/ 210

This International Searching Authority found multiple (groups of) inventions in this international application, as follows:

1. claims: 1,25,36 [partially], 2 [fully]

Method of detecting an infection in a wound caused by an infecting organism at a wound site by applying reduced pressure; withdrawing fluid from the wound site in response to the reduced pressure; and analyzing the fluid withdrawn from the wound site to identify a product of the infection or a component of an infecting organism; whereby the presence of the product or the component indicates the presence of an infection in the wound and the infecting organism is a bacterium

2. claims: 1,25,36 [partially], 3 [fully]

Method of detecting an infection in a wound caused by an infecting organism at a wound site by applying reduced pressure; withdrawing fluid from the wound site in response to the reduced pressure; and analyzing the fluid withdrawn from the wound site to identify a product of the infection or a component of an infecting organism; whereby the presence of the product or the component indicates the presence of an infection in the wound and wherein the tissues are selected from the group consisting of dermal tissue, bone tissue, cartilage, tendon, ligament, muscle, nerve tissue, subcutaneous tissue, and adipose tissue.

3. claims: 1,25,36 [partially], 4-9, 26,27 [fully]

Method and system of detecting an infection in a wound caused by an infecting organism at a wound site by applying reduced pressure; withdrawing fluid from the wound site in response to the reduced pressure; and analyzing the fluid withdrawn from the wound site to identify a product of the infection whereby the presence of the product indicates the presence of an infection in the wound; the product being ATP or a host protein associated with an inflammatory response

4. claims: 1,25,36 [partially], 10-17,28-32 [fully]

Methods and systems of detecting an infection in a wound caused by an infecting organism at a wound site by applying reduced pressure; withdrawing fluid from the wound site in response to the reduced pressure; and analyzing the fluid withdrawn from the wound site to identify a component of an infecting organism whereby the presence of the component indicates the presence of an infection in the wound; the component being lipopolysaccharide, lipoteichoic acid, a component of at least one specific genus or species of organism capable of causing a wound infection

FURTHER INFORMATION CONTINUED FROM PCT/ISA/ 210

5. claims: 1,25,36 [partially], 18-24 [fully]

Method and apparatus for detecting an infection in a wound caused by an infecting organism at a wound site by applying reduced pressure; withdrawing fluid from the wound site in response to the reduced pressure; and analyzing the fluid withdrawn from the wound site to identify a product of the infection or a component of an infecting organism; whereby the presence of the product or the component indicates the presence of an infection in the wound and wherein the apparatus comprises a source of reduced pressure; a porous pad adapted to deliver the reduced pressure to the wound site; a drape adapted to provide a cover over the pad and the wound site; and a conduit fluidly connecting the porous pad to the source of reduced pressure whereby fluid is withdrawn from the wound site in response to the reduced pressure.

6. claims: 33-35

A porous pad adapted for distributing reduced pressure to a wound site, wherein the pad comprises a luciferase-based system.

INTERNATIONAL SEARCH REPORT

Information on patent family members

International application No

PCT/US2009/046160

Patent document cited in search report	A1	Publication date	Patent family member(s)	Publication date
US 2002143286	A1	03-10-2002	NONE	
US 2003050594	A1	13-03-2003	NONE	
US 2003040687	A1	27-02-2003	AT 424863 T	15-03-2009
			AU 2002329844 B2	22-05-2008
			AU 2008202973 A1	31-07-2008
			BR 0212058 A	17-08-2004
			CA 2458285 A1	06-03-2003
			CN 1571682 A	26-01-2005
			CN 1973916 A	06-06-2007
			DE 07117289 T1	31-07-2008
			DE 07117293 T1	31-07-2008
			DK 1897569 T3	29-06-2009
			EP 1418973 A2	19-05-2004
			EP 2052750 A1	29-04-2009
			ES 2299412 T1	01-06-2008
			ES 2299413 T1	01-06-2008
			JP 2005500141 T	06-01-2005
			JP 2009056335 A	19-03-2009
			KR 20070072625 A	04-07-2007
			KR 20080066874 A	16-07-2008
			MX PA04001457 A	13-09-2004
			NZ 531268 A	29-09-2006
			RU 2302263 C2	10-07-2007
			WO 03018098 A2	06-03-2003
			US 2006149170 A1	06-07-2006
			ZA 200401261 A	27-05-2005
GB 2442132	A	26-03-2008	US 2008077091 A1	27-03-2008
US 2007292397	A1	20-12-2007	EP 2040720 A2	01-04-2009
			WO 2008042481 A2	10-04-2008
WO 2007092909	A	16-08-2007	NONE	

专利名称(译)	在减压伤口治疗中检测感染		
公开(公告)号	EP2281199A1	公开(公告)日	2011-02-09
申请号	EP2009759362	申请日	2009-06-03
[标]申请(专利权)人(译)	凯希特许有限公司		
申请(专利权)人(译)	KCI许可, INC.		
当前申请(专利权)人(译)	KCI许可, INC.		
[标]发明人	HUTCHINSON GEORGE KILPADI DEEPAK V PRICE NANCY MCNULTY AMY		
发明人	HUTCHINSON, GEORGE KILPADI, DEEPAK, V. PRICE, NANCY MCNULTY, AMY		
IPC分类号	G01N33/569 G01N33/68 C12Q1/66 A61L15/00 A61M1/00 A61B5/145 A61B5/00 A61B5/1459 A61L15/38 A61L15/42		
CPC分类号	A61B5/145 A61B5/14546 A61B5/1459 A61B5/445 A61L15/38 A61L15/425 A61M1/0025 A61M1/0088 A61M2202/20 A61M2205/3306 A61M2205/583 A61B46/00 C12Q1/66 G01N33/56911 G01N2800/26 A61B5/0082 A61B5/1455 A61B2562/0233 A61F13/00063 A61F13/00068 C12Q1/04 C12Q1/37 C12Q1/689 G01N33/6893		
优先权	61/058819 2008-06-04 US 61/118161 2008-11-26 US		
其他公开文献	EP2281199B1		
外部链接	Espacenet		

摘要(译)

提供一种检测由伤口部位的感染生物引起的伤口感染的方法。还提供了一种用于检测伤口部位的伤口感染的系统。另外, 提供了包含荧光素酶的多孔垫。